

Quick Installation Guide

EASYZONE

Español

English

Français

Italiano

Português

Deutsch

Magyar

Svenska

Nederlands

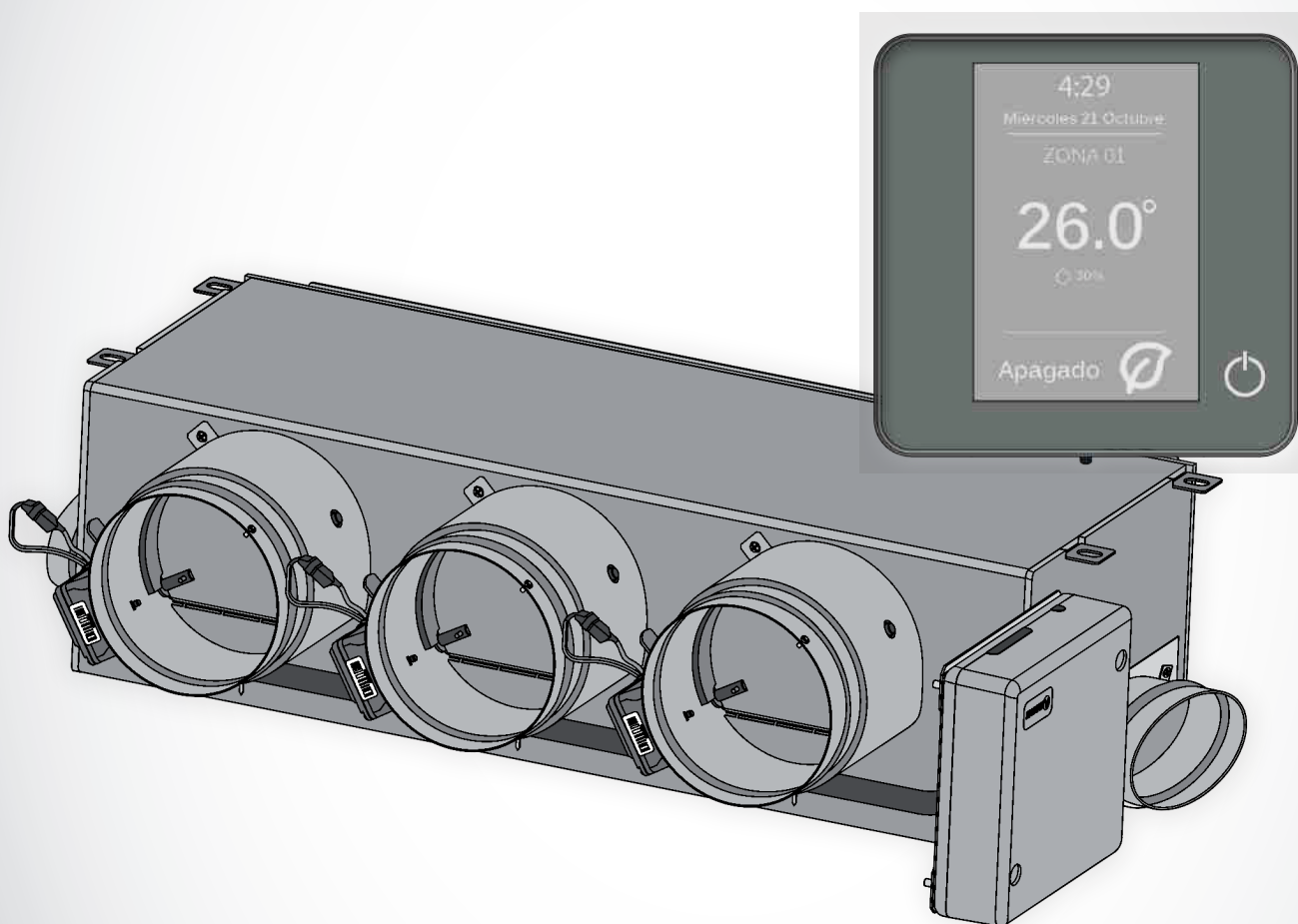

CONTENTS

Warnings and environmental policy.....	25
Precautions.....	25
Environmental policy.....	25
General requirements.....	26
System elements.....	27
Innobus Pro6 main control board (AZCE6IBPRO6).....	27
Technical specs.....	27
Daikin communication gateway (AZX6QADAPTDAI).....	28
Technical specs.....	28
Blueface intelligent thermostat (AZCE6BLUEFACEC).....	28
Technical specs.....	29
Wireless Think thermostat (AZCE6THINKR).....	29
Technical specs.....	29
Wireless Lite thermostat (AZCE6LITER).....	30
Technical specs.....	30
Standard motorized plenum (AZEZ6DAIST).....	30
Low profile motorized plenum (AZEZ6DAISL).....	31
System installation.....	31
System assembly.....	32
Easyzone assembly.....	32
Assembly to indoor unit.....	32
Bypass damper assembly.....	33
Ventilation air inlet assembly.....	33
How to change the actuator.....	34
Thermostat assembly (AZCE6BLUEFACEC / AZCE6THINKR / AZCE6LITER).....	35
Indoor unit connection.....	35
System assembly.....	36
Innobus Pro6 main control board (AZCE6IBPRO6).....	36
Reset the system.....	37
Changing batteries.....	37
Assembly and connection evaluation.....	37
Initial configuration.....	37
Blueface and Think thermostats.....	38
Lite thermostat.....	39
Lite thermostat reset.....	40
Initial Configuration evaluation.....	40
Flow regulation.....	40
Flow adjustment (REG).....	40
Minimum air setting (A-M).....	41
Advanced settings.....	41
System parameters.....	42
Zone Parameters.....	42
Self-diagnose.....	43
Innobus Pro6 main control board (AZCE6IBPRO6).....	43
Daikin communication gateway (AZX6QADAPTDAI).....	44
Blueface and Think thermostat (AZCE6BLUEFACEC / AZCE6THINKR).....	44
Wireless Lite thermostat (AZCE6LITER).....	44

WARNINGS AND ENVIRONMENTAL POLICY

PRECAUTIONS

For your security, and to protect the devices, follow these instructions:

- Do not handle the system with wet or damp hands.
- Disconnect the power supply before making any connections.
- Take care not to cause a short circuit in any of the system connections.

EN

ENVIRONMENTAL POLICY



Do not dispose of this equipment in the household waste. Electrical and electronic equipment contain substances that may damage the environment if they are not handled appropriately. The symbol of a crossed-out waste bin indicates that electrical equipment should be collected separately from other urban waste. For correct environmental management, it must be taken to the collection centres provided for this purpose, at the end of its useful life.

The equipment's components may be recycled. Act in accordance with current regulations on environmental protection.

If you replace it with other equipment, you must return it to the distributor or take it to a specialized collection center.

Those breaking the law or by-laws will be subject to such fines and measures as are laid down in environmental protection legislation.

Access all our technical documents and the self-diagnosis section, check the most FAQs, certificates and watch our videos at: myzone.airzone.es/products/

Access our declaration of conformity at:
http://doc.airzone.es/producto/Gama_AZ6/Airzone/Certificados/Declaracion_of_conformity_AZ6.pdf



Hereby, Corporación Empresarial Altra, S.L., declares that the AZEZ6DAIxxxxxxx is in compliance with the essential requirements and other relevant provisions of directive 2014/53/EU.

GENERAL REQUIREMENTS

Strictly follow the directions outlined in this manual:

- This system must be installed by a qualified technician.
- Make all the connections with total absence of power.
- Set and connect the elements in accordance with the electronic regulations in force.
- In order to connect the elements of the system, use the Airzone cable: shielded twisted cable formed by 4 wires (2x0.22 mm² + 2x0.5mm²).
- Do not connect the "-" pole in the "+" terminal. It may damage the device.
- Do not place the system bus close to lines of force, fluorescent lights, motors, etc. It might cause interference on communications.
- Follow these recommendations to locate the thermostats:

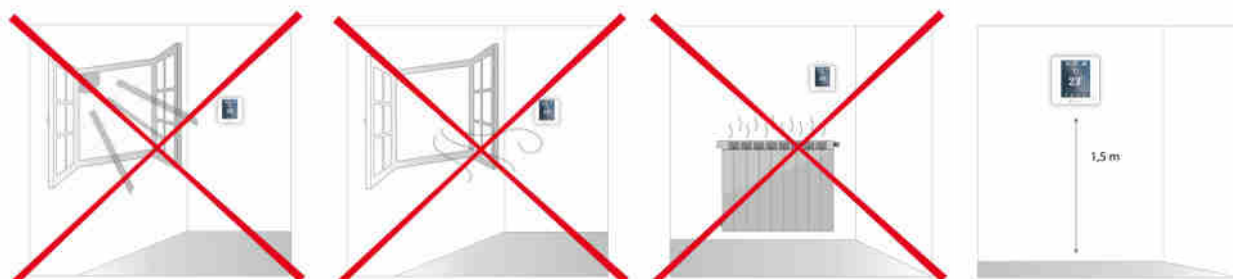

Important: According to the current local and national regulations, it is mandatory to add a switch (or other element to disconnect the system) to the external supply wiring so that a constant separation between poles is guaranteed. The system will restart automatically if the supply is eventually turned off.

INNOBUS PRO6 MAIN CONTROL BOARD (AZCE6IBPRO6)

Electronic board that controls the system through wired and wireless devices. Wall mounted.

Functionalities:

- Control and management of the thermostats (up to 6 zones).
- Power outlets for motorised elements.
- Remote zone on/off module (up to 6 zones).
- Only heat module, restricting the available modes to Stop, Heating and Ventilation.
- Relay outlet configurable as CMV (Controlled Mechanical Ventilation) or boiler.
- Control gateway management.
- Communication with units of integral control of the installation.
- Communications with other external control systems through integration bus.

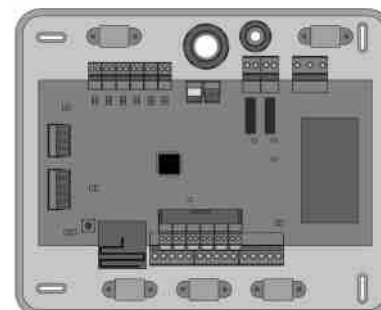

EN

Technical specs

Power supply and consumption	
Type of power supply	Vac
V max	110 / 230 V
I max	250 mA
Frequency	60/50 Hz
Stand-by consumption	400 mW
Maximum consumption	25 W
Module over-current protection	250 mA
Communications via radio	
Communications protocol	Airzone
Frequency	868 MHz
Radiation power	5 dBm
	40 m
Operating temperatures	
Storage	-20 ... 70 °C
Operation	0 ... 50°C
Mechanical aspects	
Protection class	IP 20
Weight	616 g
Dimensions (WxHxD)	195x180x55,5 mm

Airzone connection bus	
N° of ports	3
Shielded twisted pair	2 x 0,22 + 2x0,5 mm ²
V max	12 V
Automation bus	
N° of ports	1
Shielded twisted pair	2 x 0,22 + 2x0,5 mm ²
Communications protocol	MODBUS RS-485 Par – 19200 bps
Actuator outputs	
N° of outputs	6
Maximum number of outputs per damper	2
Vmax	± 12 V
I max	150 mA
Relay outputs	
N° of relays	2
V max	24 / 48 V
I max	I max



Type	Airzone Central V1.3	
Licence	215562	
Application	Variable air volume system (without h/c coil)	
	Heating	Cooling
Control accuracy (K)	0.3	0.3

DAIKIN COMMUNICATION GATEWAY (AZX6QADAPTDAL)

Element that fully integrates Daikin AC units and Airzone zoning systems, enhancing the performance of the installation:

- ON/OFF depending on the number of zones in demand.
- Automatic mode changeover (Stop, Ventilation, Cooling, Heating or Dry) from master thermostat.
- Automatic fan speed selection based on the number of zones on demand.
- Set-point temperature adjustment based on the set-point temperatures of the zone thermostats of the system and Eco Adapt algorithm.

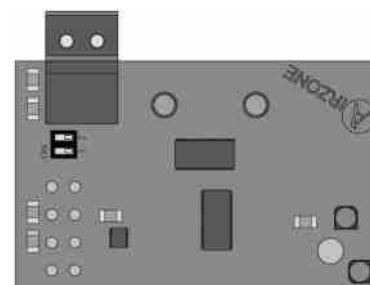

Technical specs

Power supply and consumption	
Power supply	Indoor unit
V max	16 Vdc
I max	25 mA
Communications	
Type of cable	Shielded twisted pair
Communication wires	2 x 0,75 mm ²
Operating temperatures	
Storage	-20 ... 70 °C
Operation	0 ... 50°C

You can find compatibility information on the Daikin communication gateway at:

http://doc.airzone.es/producto/Gama_AZ6/Airzone/Comunes/Fichas_tecnicas/Pasarelas_comunicaciones/Compatibilidades/UC_AZX6QADAPTDAL_MUL.pdf

BLUEFACE INTELLIGENT THERMOSTAT (AZCE6BLUEFACEC)

Colour graphic interface with capacitive screen for controlling zones in Airzone systems. Powered by main control board. Finish ed in steel and glass. Available in white or black.

Functionalities:

- Available in Spanish, English, French, Italian, German and Portuguese.
- Control of temperature, operating mode (Master thermostat) and system speed (Master thermostat and fancoil installations).
- Room temperature and relative humidity measurement of the zone.
- Eco-Adapt saving and Sleep function.
- Temperature and mode time schedules.
- Remote access to other zones of the system.



Technical specs

Power supply and consumption	
Type of power supply	Vdc
V max	12 V
I max	145 mA
Stand-by consumption	0,876 W
Maximum consumption	1,74 W
Connection and communications	
Type of cable	Shielded twisted pair
Communication wires	2 x 0,22 mm ²
Power supply wires	2 x 0,5 mm ²
Maximum distance	40 m

Operating temperatures	
Storage	-20 ... 70 °C
Operation	0 ... 50°C
Set-point temperature range	15 ... 30°C
Reading accuracy	±0,1 °C
Display accuracy	±0,1 °C
Relative humidity	±4 %
Mechanical aspects	
Assembly	Surface through support
Protection class	IP 20
Type of probe	Airzone_NTC_10K
Weight	198 g
Dimensions (WxHxD)	92x 92x15,85 mm

EN

WIRELESS THINK THERMOSTAT (AZCE6THINKR)

Graphic interface with low-energy e-ink screen and capacitive buttons for controlling zones in Airzone systems. Wireless communications. Powered by battery button CR2450. Finished in steel and glass. Available in white or black.

Functionalities:

- Available in Spanish, English, French, Italian, German and Portuguese.
- Control of temperature, operating mode (Master thermostat) and system speed (Master thermostat and in fancoil installations).
- Room temperature and relative humidity reading.
- Sleep function.



Technical specs

Power supply and consumption	
Type of power supply	Vdc
V max	3,3 V
I max	30 mA
Battery	CR2450
Useful life of battery	2 years
Stand-by consumption	0,01 mW
Maximum consumption	100 mW
Connection and communications	
Communication frequency	868 MHz
Maximum power	0 dBm
Maximum distance in open space	40 m

Operating temperatures	
Storage	-20 ... 70 °C
Operation	0 ... 50°C
Set-point temperature range	15 ... 30°C
Reading accuracy	±0,1 °C
Display accuracy	±0,1 °C
Relative humidity	±4 %
Mechanical aspects	
Assembly	Surface through support
Protection class	IP 20
Type of probe	Airzone_NTC_10K
Weight	180 g
Dimensions (WxHxD)	92x 92x15,85 mm

WIRELESS LITE THERMOSTAT (AZCE6LITER)

Thermostat with capacitive buttons for controlling the temperature of the zones in Airzone systems. Finished in steel and glass. Wireless communications. Powered by CR2450 button battery. Available in white and black.

Functionalities:

- On/off of the zone.
- Set-point temperature control (Accuracy: $\pm 1^\circ\text{C}$, up to a limit of $\pm 3^\circ\text{C}$.)
- Room temperature and relative humidity reading.



Technical specs

Power supply and consumption	
Type of power supply	Vdc
V max	3,3 V
I max	30 mA
Battery	CR2450
Useful life of battery	2 years
Stand-by consumption	0,01 mW
Maximum consumption	100 mW
Connection and communications	
Communication frequency	868 MHz
Maximum power	0 dBm
Maximum distance in open space	40 m

Operating temperatures	
Storage	-20 ... 70 °C
Operation	0 ... 50°C
Set-point temperature range	15 ... 30°C
Reading accuracy	$\pm 0,1^\circ\text{C}$
Display accuracy	$\pm 0,1^\circ\text{C}$
Relative humidity	$\pm 4\%$
Mechanical aspects	
Assembly	Surface through support
Protection class	IP 20
Type of probe	Airzone_NTC_10K
Weight	184 g
Dimensions (WxHxD)	92x 92x15,85 mm

STANDARD MOTORIZED PLENUM (AZEZ6DAIST)

Airzone standard motorized plenum includes:

- Main board.
- Communication gateway
- Circular dampers of 200 mm in diameter.
- Manual control system of flow.
- Controlled mechanical ventilation (CMV) input of 150 mm in diameter.

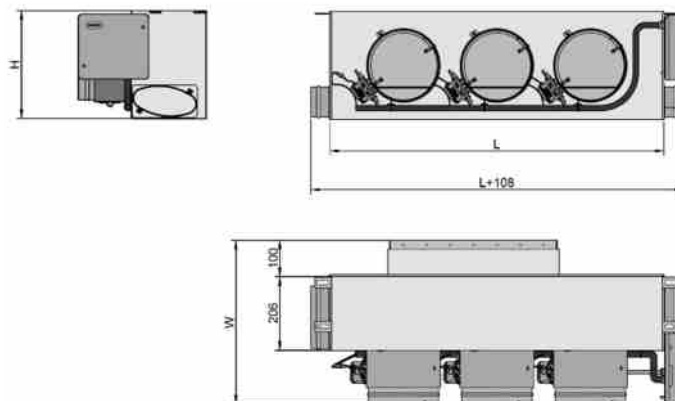

Variations of up to ± 3 dB(A) over the sound pressure of the indoor unit. Maximum weight = 18 kg.

Size	XS	S	M	L	XL
No. of dampers	Size in mm (L x W x H)				
2 / 3	930 x 300 x 454	930 x 300 x 454			
4		1140 x 300 x 454	1140 x 300 x 454		
5		1425 x 300 x 454	1425 x 300 x 454	1425 x 300 x 454	
6			1638 x 300 x 454	1638 x 300 x 454	
7 / 8				1425 x 515 x 454	1425 x 515 x 454

Plenum code: AZEZ6DAIST07 [Size] [No. of dampers]

LOW PROFILE MOTORIZED PLENUM (AZEZ6DAISL)

Airzone low profile motorized plenum includes:

- Main board.
- Communication gateway.
- Circular dampers of 150 mm in diameter.
- Manual control system of flow.
- Controlled mechanical ventilation (CMV) input of 150 mm in diameter.

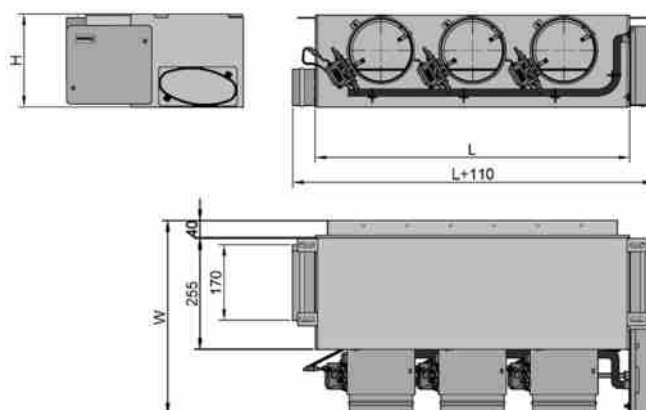

Variations of up to ± 3 dB(A) over the sound pressure of the indoor unit. Maximum weight = 18 kg.

Size	S	M	L
No. of dampers	Size in mm (L x W x H)		
2 / 3	720 x 210 x 444		
4		930 x 210 x 444	
5			1140 x 210 x 444

Plenum code: AZEZ6DAISL01 [Size] [No. of dampers]

SYSTEM INSTALLATION

In order to install the system, carefully follow these steps:

- 1) Connect all the necessary elements** (see section *System assembly*)
 - Connect the communication gateway whit the AC indoor unit to controller.
 - Connect all the elements of the system (thermostats, modules, etc.).
 - Power the main board.
- 2) Check all the assembly and the connection are correct** (see section *Assembly and connection evaluation*)
- 3) Configure the system**
 - Configure all the thermostats (see sections *Initial configuration* and *Advanced settings*).
 - Remember that Airzone system allow you to configure master and zone thermostats (Master thermostats let you change operating modes, select the efficiency degree with the Eco-Adapt function or select the speed of the system).
- 4) If you have any other doubt, check the user and installation manuals**
- 5) It does not require any maintenance**

EASYZONE ASSEMBLY

Important: It is recommended to insulate all the metal parts of Easyzone that are exposed to outdoor conditions in order to prevent condensation.

Remember: The motorized elements are numbered the following way:

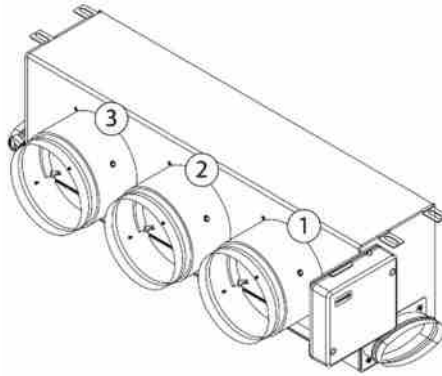

ASSEMBLY TO INDOOR UNIT

- 1 Place the Easyzone in the pressure port of the unit and attach it to this using the screws.
- 2 After fixing screws be sure to insulate the connection frame to prevent condensation forming. Use bands of insulating material (glass wool or polyethylene foam) of a thickness of 25 mm. The width of the insulation bands are 97 mm for standard motorized plenum and 36 mm for low profile motorized plenum.
- 3 Attach the Easyzone to the ceiling through the tabs on the ends with threaded rods.

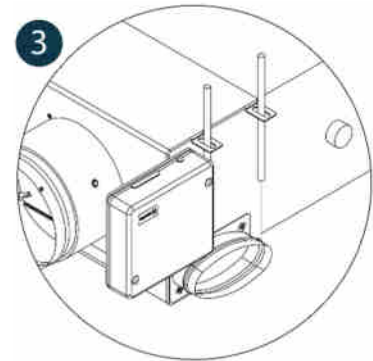
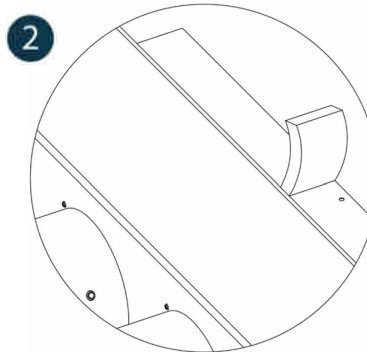
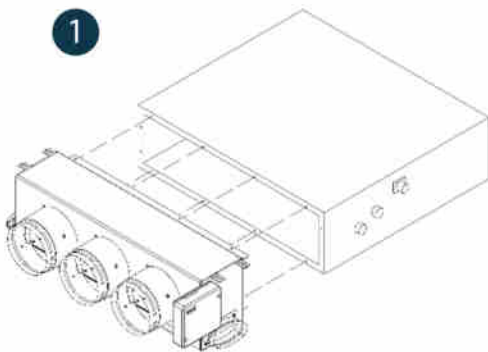

BYPASS DAMPER ASSEMBLY

- 1 Sharply hit it to take away the pre-cut area of the sides corresponding to the bypass.
- 2 Use a sharp blade to remove the insulation that covers the area of the bypass and uncover the mounting slots on the bypass.
- 3 Fit the bypass damper in the slots and rotate it clockwise until the stop.
- 4 Attach the bypass damper to the plenum using a sheet metal screw (Ø: 3.9MM).

EN

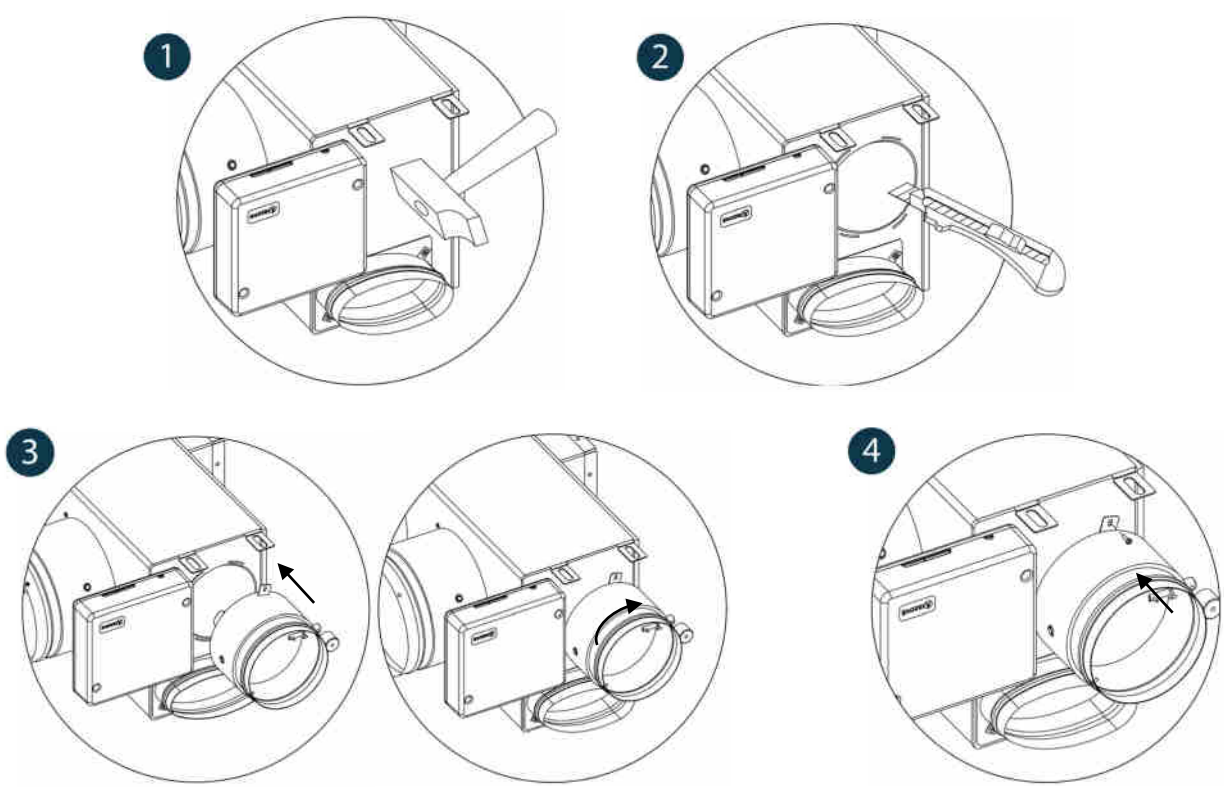

VENTILATION AIR INLET ASSEMBLY

- 1 Remove the elliptical neck that is secured by screws.
- 2 Remove the protection plate that covers the external air intake and reattach the elliptical neck.
- 3 Double or cut the lid at the bottom of the pressure dampers to allow the air to pass.

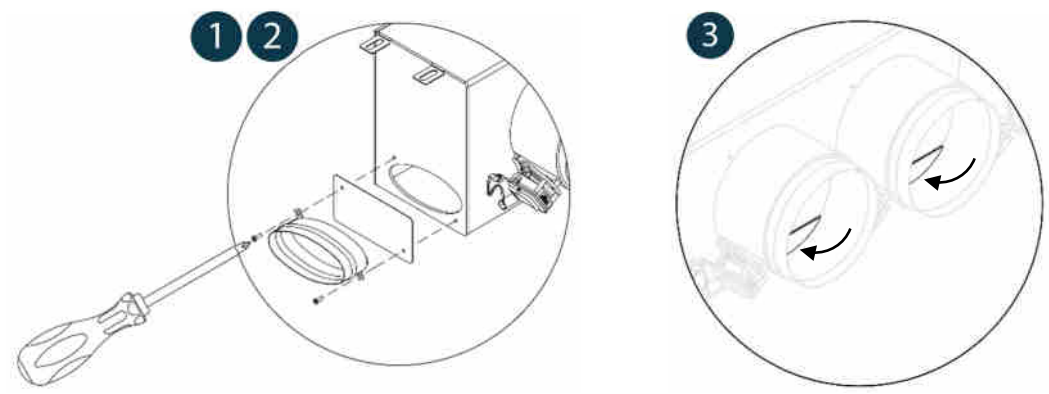

HOW TO CHANGE THE ACTUATOR

- 1 Disconnect the actuator.
- 2 Loosen the fixing screw using an Allen key (number 3) and remove the actuator from the damper.
- 3 Fix the new actuator to fit in the bolt.
- 4 Turn the actuator until it fits in the second bolt to guarantee the proper position of the damper.
- 5 Insert and screw the fixing screw.
- 6 Connect the cable.

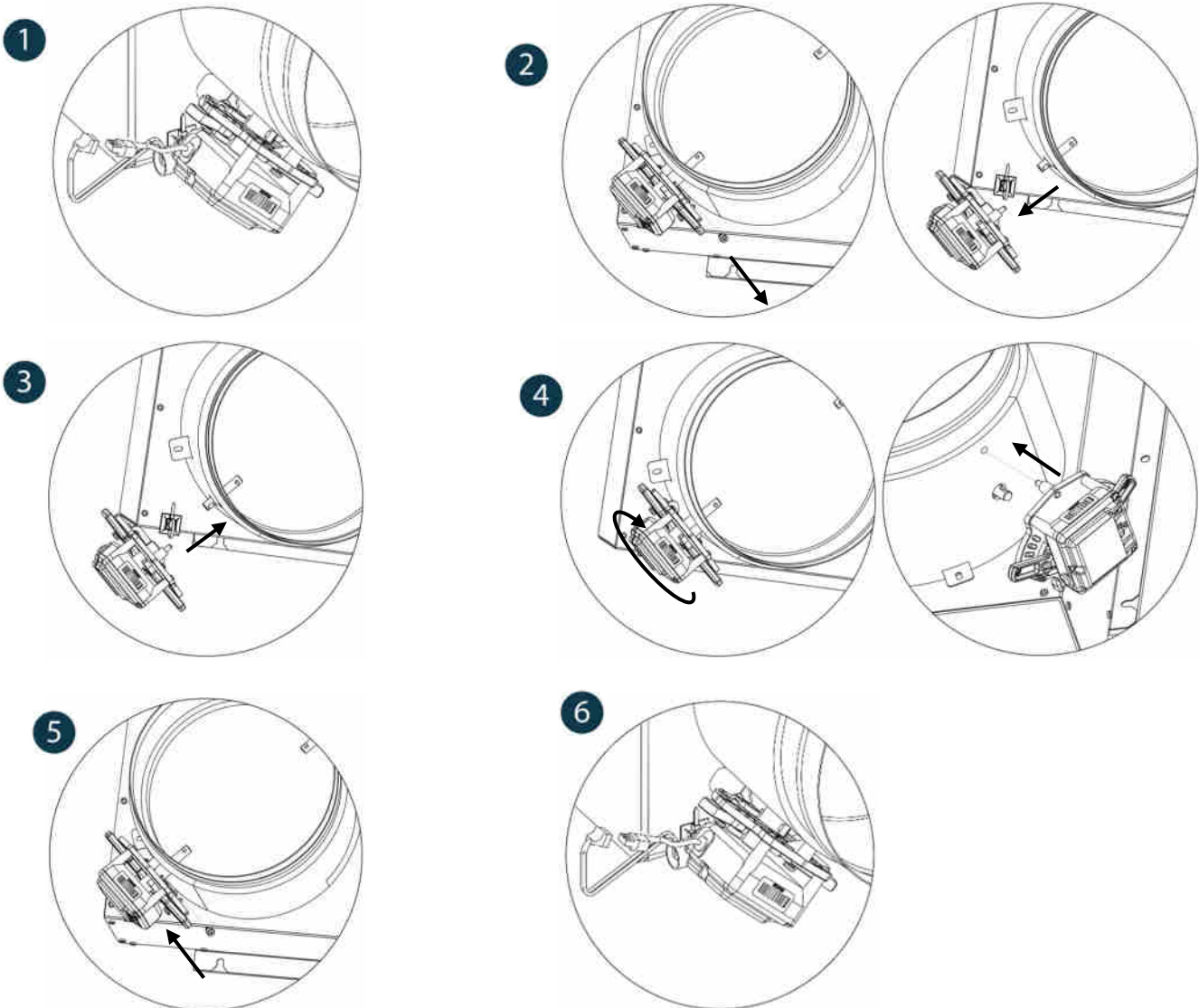

THERMOSTAT ASSEMBLY (AZCE6BLUEFACEC / AZCE6THINKR / AZCE6LITER)

Airzone thermostats are mounted on the wall through a support. It is recommended not to locate it more than 40 meters away from the main control board. To fix it to the wall, follow these steps:

- Separate the back part of the thermostat from the wall support and make all the connections (AZCE6BLUEFACEC) or insert the CR2450 button battery (AZCE6THINKR and AZCE6LITER).
- Fix the back part of the thermostat to the wall.
- Place the display on the support once it is fixed.
- Place the anti-theft rods for additional support (optional).

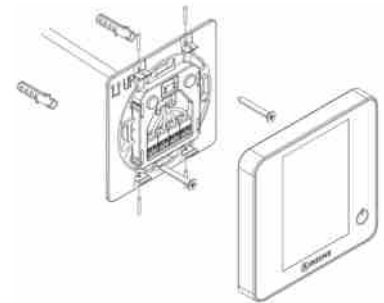

EN

INDOOR UNIT CONNECTION

- 1 Disconnect the power supply of the Daikin indoor unit and the Airzone system.
- 2 Find the **P1, P2** connection of the Daikin indoor unit (where the thermostat is connected).
- 3 Connect the Airzone Gateway to the **P1 P2** port of the Daikin unit using the twisted shielded cable supplied by Airzone. Do not forget to respect the polarity.

Remember: Do not place the system bus close to lines of force, fluorescent lights, motors, etc. It might cause interference on communications.

- 4 Configure the microswitchs as required (see Microswitch table).
- 5 Power the Daikin indoor unit and the Airzone system. Check the gateway LEDs (self-diagnosis).

Note: Disable the Stand by function using the Daikin controllers for a proper operation of the Airzone system.

Service Settings > Field Settings > 1e-2-01.

If you have any doubt, please check the Instruction manual Daikin BRC1E52A7.

SW1	Algorithm
	ON*
	OFF
	Set point
SW1	Defrost
	OFF*
	ON

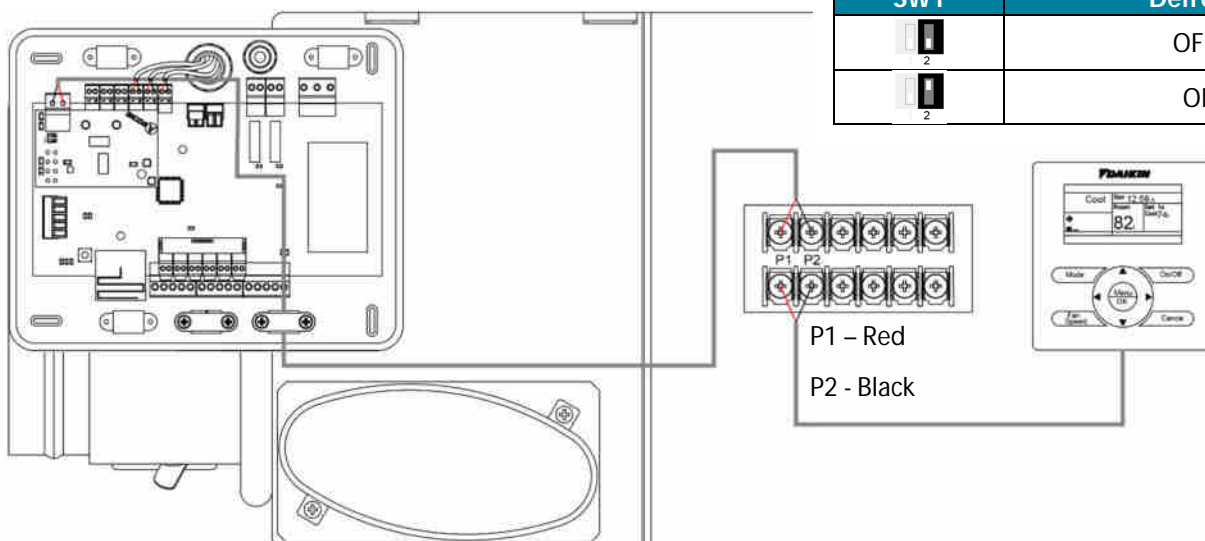

INNOBUS PRO6 MAIN CONTROL BOARD (AZCE6IBPRO6)

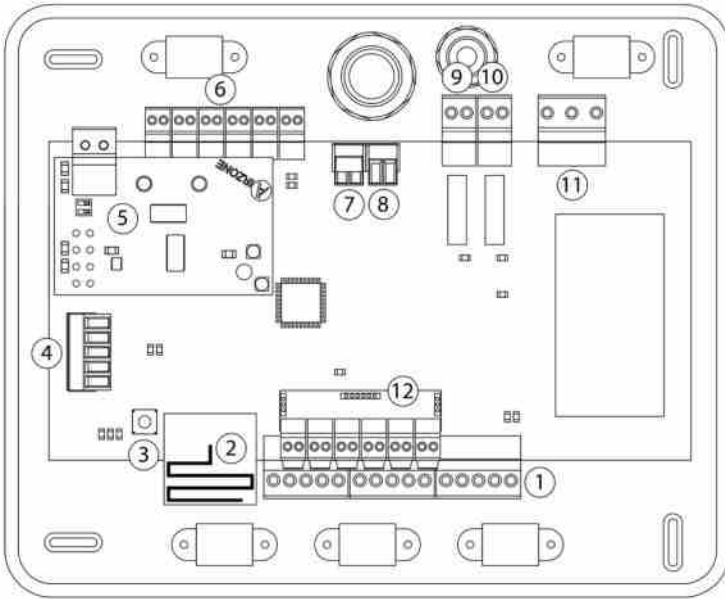

No.	Description
1	Airzone connection bus
2	Wireless module
3	SW1
4	Domotic bus
5	Daikin gateway
6	Actuator outputs
7	Alarm input (normally closed)
8	Only heat module
9	CMV/Boiler
10	AC Start-stop relay
11	Power supply
12	On/off module

Important: Use a shielded twisted cable to control the inputs of the on/off module.

1.- Airzone thermostats

Connect the control elements of the system in any of the 3 Airzone connection bus terminals ①. The connection can be both a Bus connection or a star connection. Follow the color code. For added security, secure the wires using the turrets.

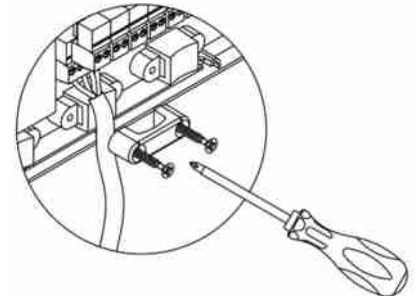
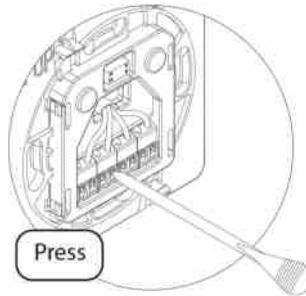
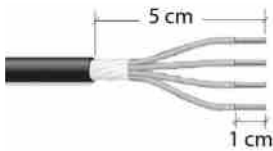
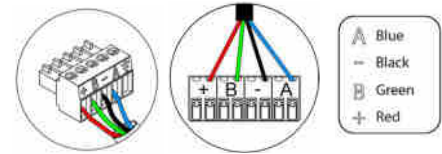

In case of wireless element, check it has the battery on.

2.- Powering the system

Use the power input to power at 110 / 230 Vac ⑪ the main control board and any others control elements that require it. Use the appropriate cable (3x1.5 mm²). To power supply the Main Board of the system, loosen the cable gland if necessary and insert the cable through the hole (Ø: 5-10 mm), attach the cables with the terminal following the indicated polarity. Connect the terminal to the power supply input and tighten the cable gland to attach the power supply cable.

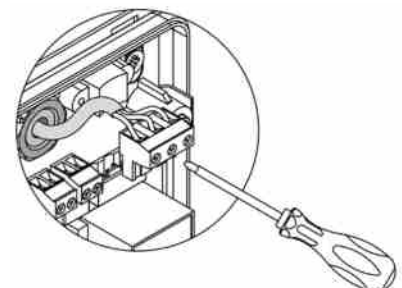
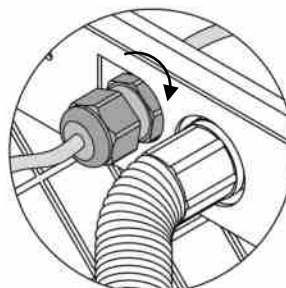
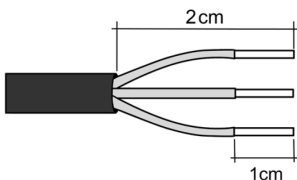
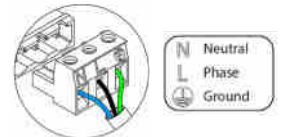

Important: According to the current local and national regulations, it is mandatory to add a switch (or other element to disconnect the system) to the external supply wiring so that a constant separation between poles is guaranteed. The system will restart automatically if the supply is eventually turned off.

Remember: Once all the connections are made, make sure you replace the cover properly.

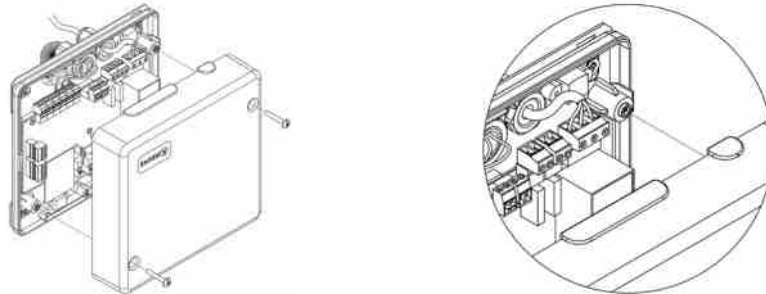

EN

Reset the system

If you want to return to factory values, press and hold SW1 ³ until LED D19 stops flashing. Wait for the LEDs to go back to their normal state before starting with the initial configuration process.

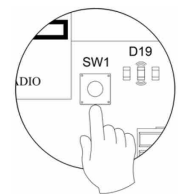

Changing batteries

To replace the battery, separate the thermostat from its support and replace the battery (CR2450).

Important: We recommend using of top-brand batteries. Using low-quality batteries may reduce the duration of use.

Remember to deposit the old battery into an appropriate recycling point.

Note: Do not forget to remove the security system before taking away the thermostat from the wall.

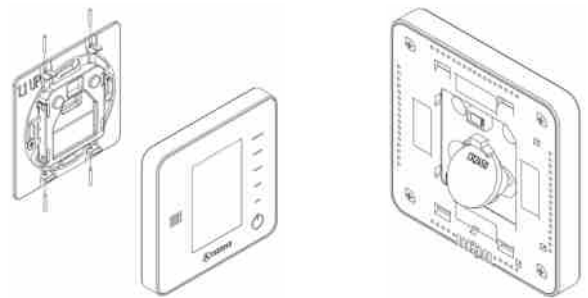

ASSEMBLY AND CONNECTION EVALUATION

Check the following aspects:

- The state of the LEDs of the main control board and the rest of control elements. Check the self-diagnose section.
- Wired and wireless thermostats power supply.

INITIAL CONFIGURATION

IMPORTANT: In order to associate wireless thermostats, you must open before the wireless module. To do that, press on SW1. The LED D19 will remain steady red. Once open, you have 15 minutes to make the association. If that period of time expires, start the process over again. Remember not to open more than one module at the same time, it may alter the process.

You can also open the channel association radio through the Blueface and Think (see section *System parameters*).

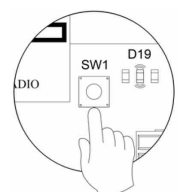

BLUEFACE AND THINK THERMOSTATS

Important: Once you start the process, it cannot be interrupted.

1 Language/Country

Select your language and country. These are the available languages: Spanish, English, French, Italian, German and Portuguese.

To associate a Think, press Airzone to start seeking and then confirm the wireless association. Verify **the range is correct** (minimum 30%) and confirm.

2 Zone address

Select the zone associated to the thermostat. All the zones have a corresponding control output. For example, the zone 1 will control the actuator output 1.

3 Associated outputs

If necessary, the system allows you to associate more than one control output to a zone. It is possible to control multiple outputs from the same thermostat.

4 Thermostat configuration

Select the operation of the thermostat:

- Master: Controls all the parameters of the installation.
- Zone: Controls all the parameters of the zone.

5 Other settings

Access the advanced settings menu (system address, stages of control, etc.) to change any other setting. Activate the basic function if required (see *Advanced Settings, zone parameters*).

Blueface

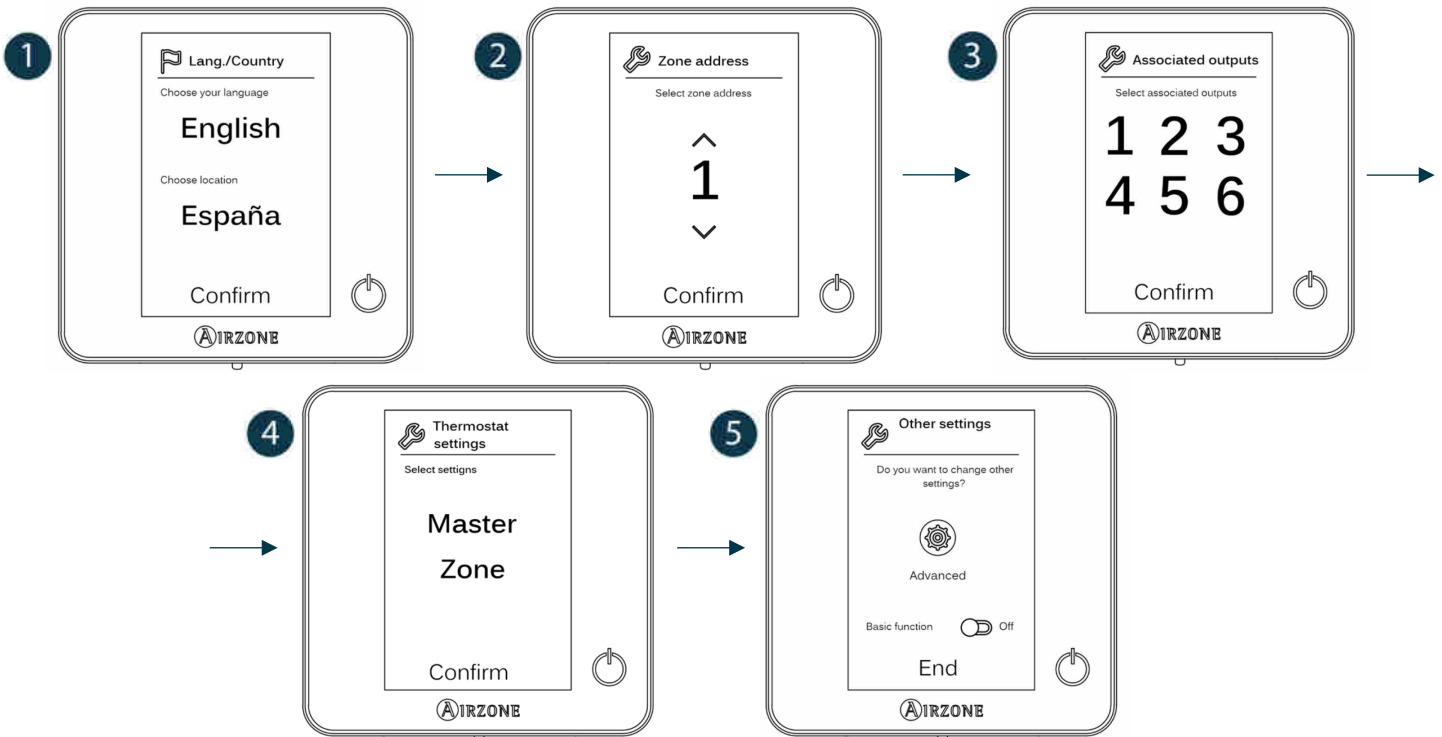

Think

Important: Use to confirm and to return.

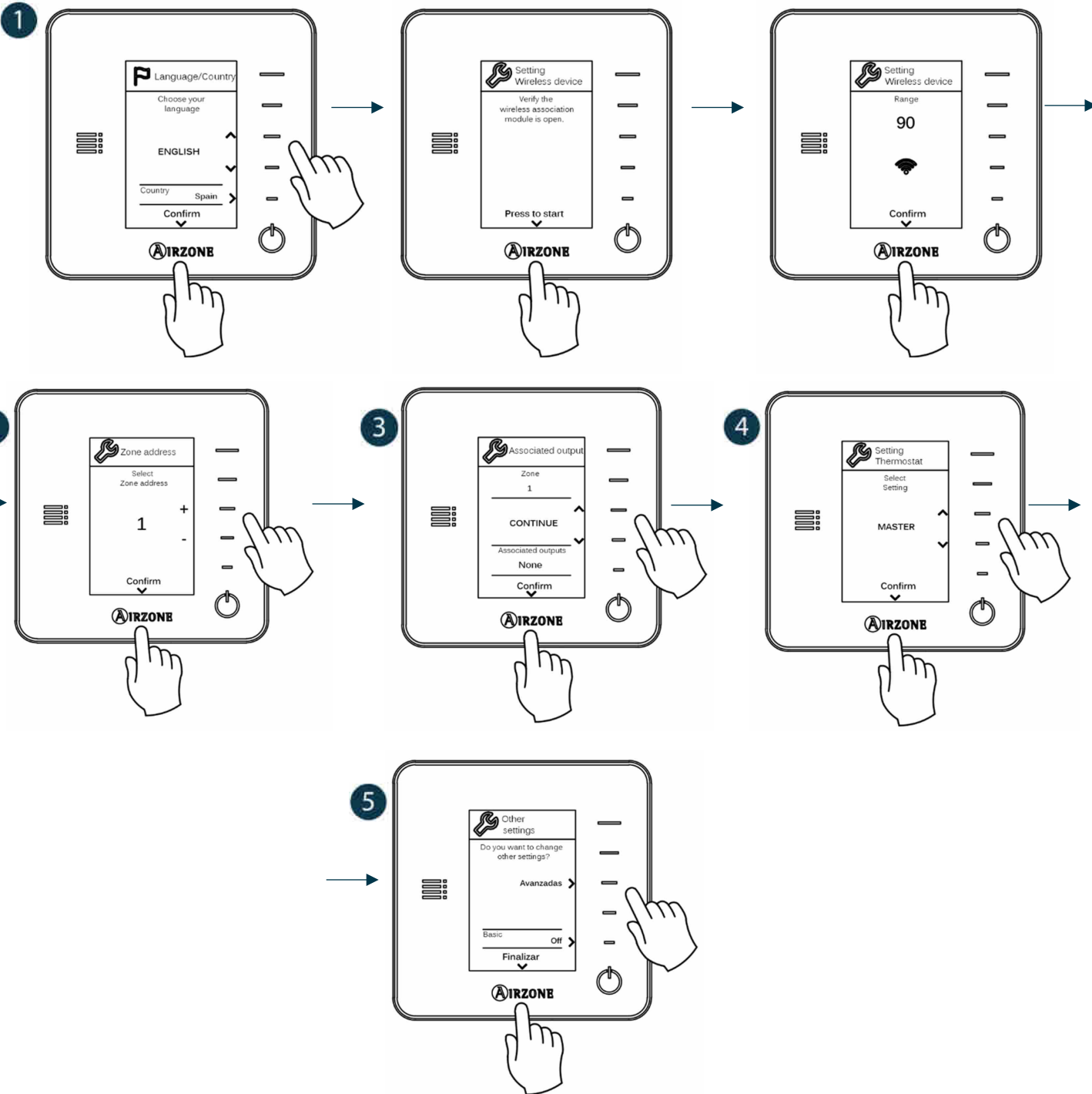

EN

LITE THERMOSTAT

Important: To configure a Lite thermostat you must move it away from its base. Once the microswitches are configured, put it back in its original position.

1) Zone address

Select the zone associated to the thermostat pulling up the microswitch of the corresponding zone.

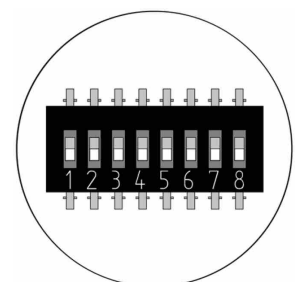
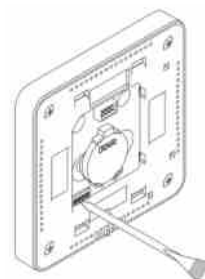

2) Associated outputs

If required, select other control outputs associated to the zone. **The address zone will be the one with a lower value.**

3) Other settings

Configure other functionalities of the LITE thermostat from the advanced configuration menu of a Blueface thermostat (see section Advanced Settings, Zone parameters).

EN

If the association is correct, the icon  will flash green 5 times. If it flashes red, it means the zone is already occupied. If it flashes red twice, it means the thermostat is out of range.

Remember: If you need to change the zone number, reset the thermostat and start association process.

Lite thermostat reset

If you want to return your Lite thermostat to factory values, pull down all the microswitchs and reinsert the thermostat in its base. Press on , the icon will flash green twice when the reset process is completed.



INITIAL CONFIGURATION EVALUATION

Check the following aspects:

- AC unit-system communication: Choose any mode (except STOP mode) and switch on the zone to generate demand.
- Opening-closing of the dampers and control outputs: Turn on the system and generate demand in all the zones. Then, switch off and on all the zones to verify the associated control outputs are correct.

Remember: For security reasons, the last zones takes 4 minutes to close.

FLOW REGULATION

Important: Start adjusting the flow from the central dampers and finish off with damper 1.

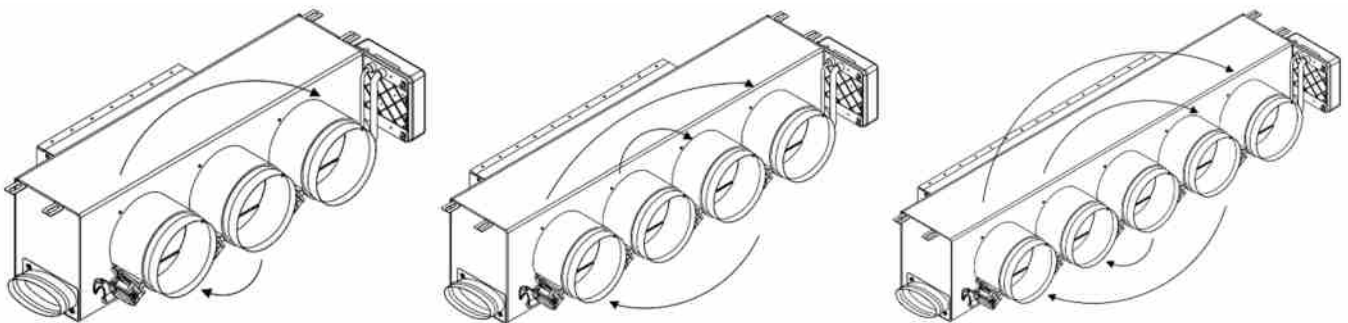

FLOW ADJUSTMENT (REG)

1. Turn on and generate demand in all zones to open all the dampers.
2. Turn off the zone/damper to be adjusted.
3. Adjust the maximum opening you want with the REG lever (I/II/III/IV)
4. Turn on the zone and check the flow is correct.

MINIMUM AIR SETTING (A-M)

1. Turn on and generate demand in all zones to open all the dampers.
2. Adjust the minimum opening you want with the M-A lever (a/b/c/d)
3. Turn on the zone and check the minimum air flow is correct.

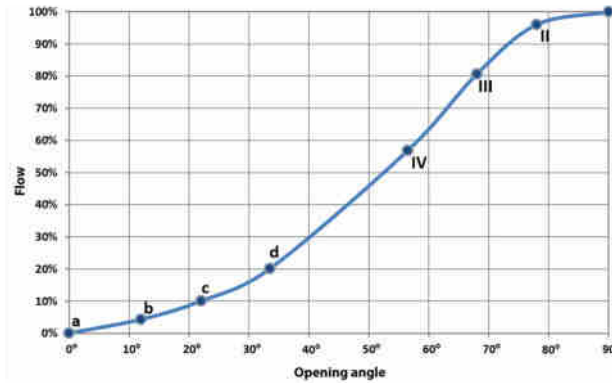
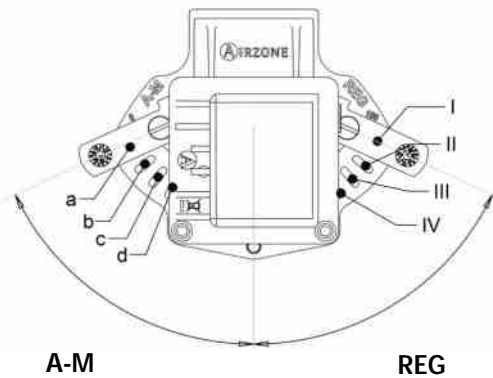

EN

ADVANCED SETTINGS

To access the advanced configuration menu of the thermostat and Blueface Think follow the following steps:

Blueface

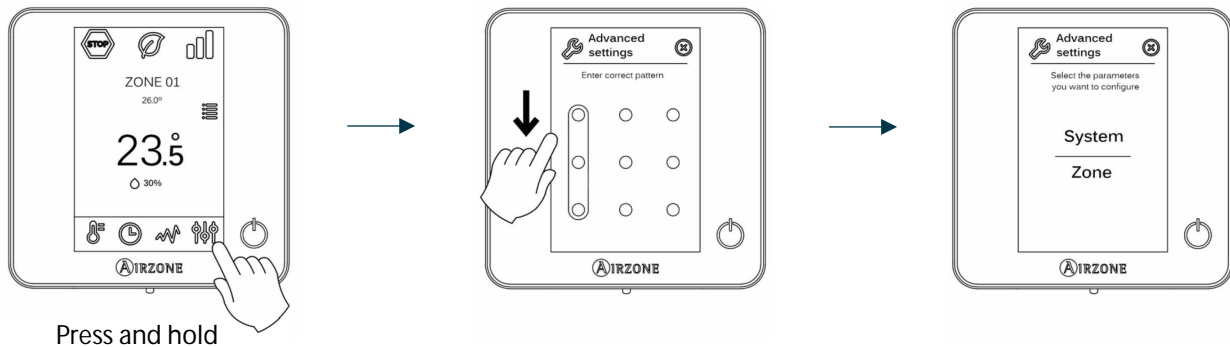

Think

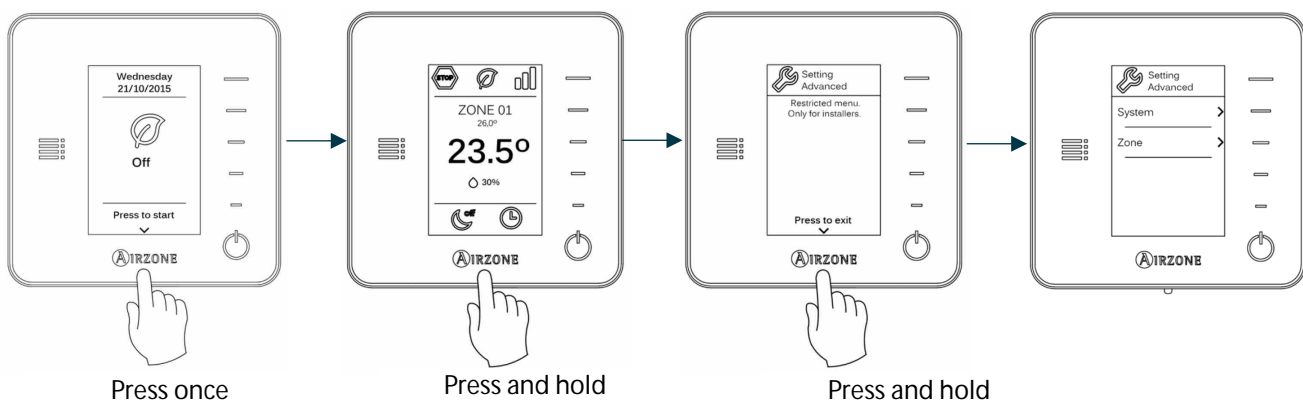

From this menu you can change the system and zone parameters.

SYSTEM PARAMETERS

- **System address.** Defines the number of the system within your installation. The value 1 is shown by default. The system will display the available values (max = 247).
- **Temperature range.** Selects the highest temperature in heating mode (19-30 °C) in steps of 1°C. It is also possible to disable the mode. The highest temperature by default is 30°C.
- **Type of opening.** Use this to activate/deactivate the proportionality in the dampers of the system. The proportionality adjusts in 4 steps the damper opening or shutting based on the temperature demand of the zone, regulating the flow. It is configured as All/nothing by default.

**Note: If you change this parameter, all the dampers of the installation will be affected. It is not recommended for RINT and RIC intelligent grilles.*
- **Relay settings.** Use this parameter to change the operation logic of the CMV/Boiler of the system main control board. (By default CMV)
- **Q-Adapt (only for Think thermostats).** It allows you to select the flow control algorithm that best suits your installation. These are the available options:
 - Maximum: The system operates at maximum speed, irrespective of the number of zones.
 - Power: The speed of the system is higher than in standard mode to increase the flow.
 - Standard: Mode by default. The system automatically regulates the speed based on the number of zones.
 - Silence: The speed of the system is lower than in standard mode to reduce the noise.
 - Minimum: The system operates at minimum speed, irrespective of the number of zones.
- **Wireless module.** It activates/deactivates the wireless association module of the system.
- **Information (only for Think thermostats).** Displays information about:
 - Zone: Firmware, zone, association, actuator o communications status.
 - System: Firmware, configuration and information about the controllers.
 - Devices: Displays what elements are connected to the system.

ZONE PARAMETERS

- **Associated outputs.** It displays and allows you to select the control outputs associated with the thermostat.
- **Thermostat settings.** Use this parameter to define the thermostat as Master or Zone.

**Note: It cannot be configured as Master if there is already another Master thermostat.*
- **Use mode.** The thermostats can be set in Basic or Advanced mode. They are set in advanced mode by default. These are the parameters you can control in basic mode:
 - On/Off.
 - Set-point temperature.
 - Fan Speed

If you need to reset the thermostat to advanced mode, access the advanced configuration menu and then activate the advanced use mode.
- **Control stages.** This parameter is used to configure heating stages in a single zone or in all the zones. These are the features to be configured:
 - Air: It activates the heating air in the zone.
 - Off: It deactivates the heating stage in the zone.

- **Offset.** Allows you to correct ambient temperature that is measured in the various areas or in all of them, due to deviations by sources of heat/cold nearby, with a correction factor between - 2,5°C and 2,5°C in steps of 0,5°C. It is in 0°C by default.
- **Reset thermostat.** Resets the thermostat returning to Setup menu (see section *Initial configuration*).

SELF-DIAGNOSE

INNOBUS PRO6 MAIN CONTROL BOARD (AZCE6IBPRO6)

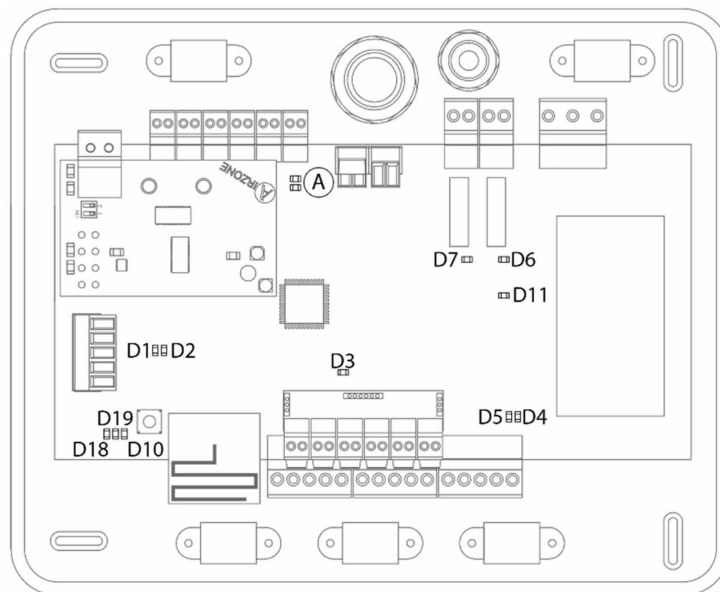

Meaning			
D1	Data reception from automation bus	Blinking	Green
D2	Data transmission from automation bus	Blinking	Red
D3	Main control board activity	Blinking	Green
D4	Data transmission from Airzone connection bus	Blinking	Red
D5	Data reception from Airzone connection bus	Blinking	Green
D6	AC unit On/Off	Blinking	Green
D7	CMV/Boiler	Blinking	Green
D10	Wireless data packets reception	Switches	Green
D11	Main control board power supply	Solid	Red
D18	Associated element	Solid	Green
D19	Association channel: active	Solid	Red
Ⓐ	Open dampers	On	Green
	Close dampers	On	Red

DAIKIN COMMUNICATION GATEWAY (AZX6QADAPTDAL)

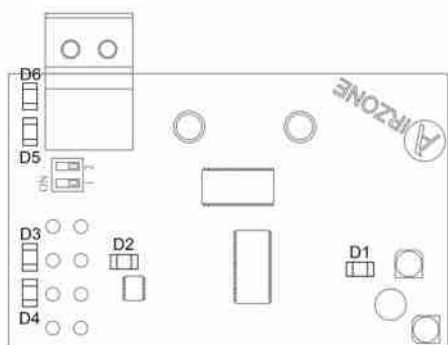

Meaning			
D1	Gateway power supply	Solid	Red
D2	Micro controller activity	Blinking	Green
D3	Data transmission to the Airzone system	Blinking	Red
D4	Data reception from the Airzone system	Blinking	Green
D5	Data transmission to the indoor unit	Blinking	Red
D6	Data reception from the indoor unit	Blinking	Green

BLUEFACE AND THINK THERMOSTAT (AZCE6BLUEFACEC / AZCE6THINKR)

Meaning	
Error 1	Error of communication with main control board
Error 5	Open-circuit temperature probe
Error 6	Short-circuit temperature probe
Error 8	Lite thermostat not found
Error 9	Gateway-system communication error
Error 11	Gateway-AC Unit communication error

WIRELESS LITE THERMOSTAT (AZCE6LITER)

Meaning		
	Blinking red quickly	Error of communication with main control board

AIRZONE

Parque Tecnológico de Andalucía

C/ Marie Curie, 21 – 29590

Campanillas – Málaga - España

Teléfono: +34 902 400 445

Fax: +34 902 400 446

<http://www.myzone.airzone.es>

Parc Tertiaire Silic – Inmeuble Panama

45 Rue Villeneuve

94573 Rungis - France

Téléphone : +33 184 884 695

Fax : +33 144 042 114

<http://www.myzone.airzonefrance.fr>

Via Fabio Filzi, 19/E – 20032

Cormano – Milano - Italia

Telefono: +39 02 56814756

Fax: +39 02 56816158

<http://www.myzone.airzoneitalia.it>

