

# Floor Console/Under Ceiling Dual Type INSTALLATION INSTRUCTION SHEET



(PART NO. 9374318094)

For authorized service personnel only.

<b>WARNING</b>	This mark indicates procedures which, if improperly performed, might lead to the death or serious injury of the user.
<b>CAUTION</b>	This mark indicates procedures which, if improperly performed, might possibly result in personal harm to the user, or damage to property.

## This air conditioner uses new refrigerant HFC (R410A).

The basic installation work procedures are the same as conventional refrigerant models. However, pay careful attention to the following points:

- Since the working pressure is 1.6 times higher than that of conventional refrigerant models, some of the piping and installation and service tools are special. (See the table below.) Especially, when replacing a conventional refrigerant model with a new refrigerant R410A model, always replace the conventional piping and flare nuts with the R410A piping and flare nuts.
- Models that use refrigerant R410A have a different charging port thread diameter to prevent erroneous charging with conventional refrigerant and for safety. Therefore, check beforehand. [The charging port thread diameter for R410A is 1/2 UNF 20 threads per inch.]
- Be more careful that foreign matter (oil, water, etc.) does not enter the piping than with refrigerant models. Also, when storing the piping, securely seal the openings by pinching, taping, etc.
- When charging the refrigerant, take into account the slight change in the composition of the gas and liquid phases, and always charge from the liquid phase side whose composition is stable.

### Special tools for R410A

Tool name	Contents of change
Gauge manifold	Pressure is high and cannot be measured with a conventional gauge. To prevent erroneous mixing of other refrigerants, the diameter of each port has been changed.
Charge hose	It is recommended the gauge with seals -0.1 to 5.3 MPa (-76 cmHg to 53 kgf/cm <sup>2</sup> ) for high pressure. -0.1 to 3.8 MPa (-76 cmHg to 38 kgf/cm <sup>2</sup> ) for low pressure.
Vacuum pump	To increase pressure resistance, the hose material and base size were changed.
Gas leakage detector	A conventional vacuum pump can be used by installing a vacuum pump adapter. Special gas leakage detector for HFC refrigerant R410A.

### Copper pipes

It is necessary to use seamless copper pipes and it is desirable that the amount of residual oil is less than 40 mg/10 m. Do not use copper pipes having a collapsed, deformed or discolored portion (especially on the interior surface). Otherwise, the expansion valve or capillary tube may become blocked with contaminants. As an air conditioner using R410A incurs pressure higher than when using conventional refrigerant, it is necessary to choose adequate materials. Thicknesses of copper pipes used with R410A are as shown in Table 1. Never use copper pipes thinner than that in the Table 1 even when it is available on the market.

Table 1 Thicknesses of Annealed Copper Pipes

Outer diameter mm (inch)	Thickness (mm)
6.35 (1/4)	R410A 0.80
9.52 (3/8)	0.80
12.7 (1/2)	0.80
15.88 (5/8)	1.00

For authorized service personnel only.

- WARNING**
- For the air conditioner to operate satisfactorily, install it as outlined in this installation instruction sheet.
  - Connect the indoor unit and outdoor unit with the air conditioner piping and cords available standards parts. This installation instruction sheet describes the correct connections using the installation set available from our standard parts.
  - Installation work must be performed in accordance with national wiring standards by authorized personnel only.
  - If refrigerant leaks while work is being carried out, ventilate the area. If the refrigerant comes in contact with a flame, it produces a toxic gas.
  - Do not use an extension cord.
  - Do not turn on the power until all installation work is complete.

**CAUTION**

This installation instruction sheet describes how to the indoor unit only. To install the outdoor unit, refer to the installation instruction sheet included with the outdoor unit.

- Be careful not to scratch the air conditioner when handling it.
- After installation, explain correct operation to the customer, using the operating manual.
- Let the customer keep this installation instruction sheet because it is used when the air conditioner is serviced or moved.

## SELECTING THE MOUNTING POSITION

**WARNING**

Install at a place that can withstand the weight of the indoor and outdoor units and install positively so that the units will not topple or fall.

**CAUTION**

- Do not install where there is the danger of combustible gas leakage.

- Do not install near heat sources.
- If children under 10 years old may approach the unit, take preventive measures so that they cannot reach the unit.

Decide the mounting position with the customer as follows:

### INDOOR UNIT

- Install the indoor unit level on a strong wall, floor, ceiling which is not subject to vibration.
- The inlet and outlet ports should not be obstructed. The air should be able to blow all over the room.
- Install the unit near an electric outlet or special branch circuit.
- Do not install the unit where it will be exposed to direct sunlight.
- Install the unit where connection to the outdoor unit is easy.
- Install the unit where the drain pipe can be easily installed.
- Take servicing, etc., into consideration and leave the spaces shown in Fig. 1. Also install the unit where the filter can be removed.

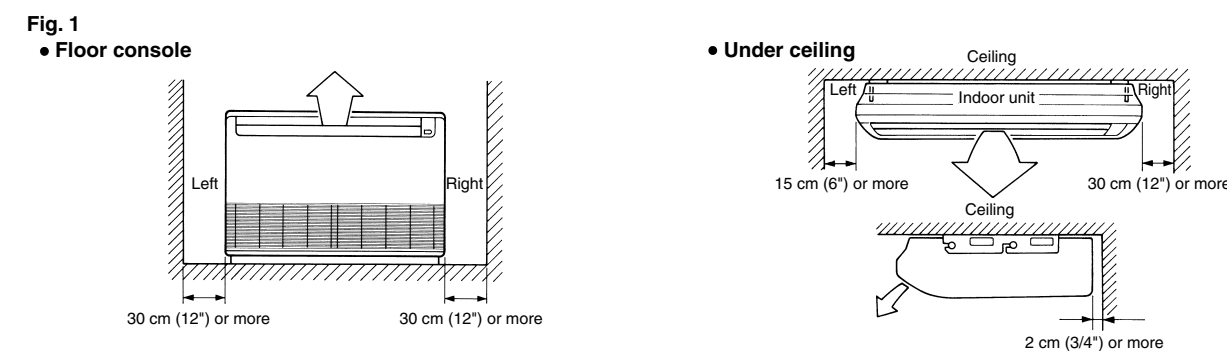

## STANDARD PARTS

The following installation parts are furnished. Use them as required.

Name and Shape	Q'ty	Application
Cover plate (left)	1	
Cover plate (right)	1	
Tapping screw (ø4 × 10)	2	
Installation template	1	For positioning the indoor unit For under ceiling type
Bracket (left)	1	For suspending the indoor unit from ceiling
Bracket (right)	1	
Anchor bolt (M12)	4	
Spring washer	4	
Special nut	4	
Wall bracket	2	For suspending the indoor unit on the wall.
Tapping screw (ø4 × 20)	6	For fixing the wall bracket.
Coupler heat insulator (large)	1	For indoor side pipe joint (Large pipe)
Coupler heat insulator (small)	1	For indoor side pipe joint (Small pipe)
Nylon fastener	1	For fixing the drain hose

Name and Shape	Q'ty	Application
Drain hose	1	
Insulation (drain hose)	1	Adhesive type 70 × 230
VT wire	1	For fixing the drain hose L 280 mm
Remote control unit	1	Use for air conditioner operation
Battery (penlight)	2	For remote control unit
Remote control unit holder	1	Use as remote control unit holder
Tapping screw (ø3 × 12)	2	For remote control unit holder installation

### OPTIONAL PARTS FOR INDOOR UNIT

Name and Shape	Part No.	Application
Joint pipe-A	9302812021	For indoor side pipe joint (24000 BTU/h model only)

## INSTALLATION PROCEDURE

Install the room air conditioner as follows:

### 1 PREPARING INDOOR UNIT INSTALLATION

#### 1. REMOVE THE INTAKE GRILLE

Open the intake grille and remove the three screws (Fig. 2).

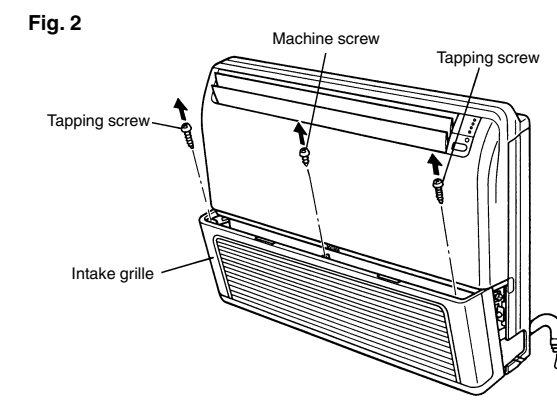

Remark: The main unit can be wired before the indoor unit is installed. Select the most appropriate installation order.

### 2 INDOOR UNIT INSTALLATION

#### A. FLOOR CONSOLE TYPE

##### 1. DRILLING FOR PIPING

Select piping and drain directions (Fig. 3). The piping and drain can be made in three directions as shown below.

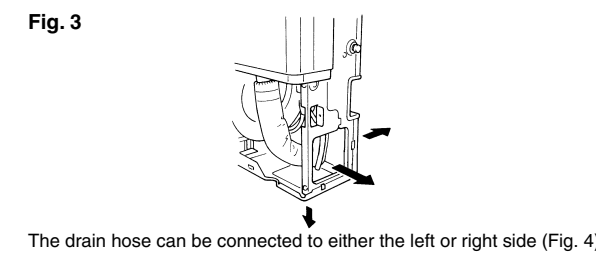

The drain hose can be connected to either the left or right side (Fig. 4).

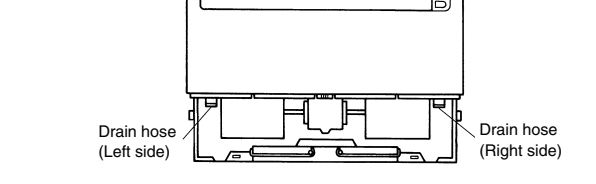

When the directions are selected, drill a 10 mm (4") dia. hole on the wall so that the hole is tilted downward toward the outdoor for smooth water flow. When the pipe is led out from the rear, make a hole in Fig. 5, at the position shown.

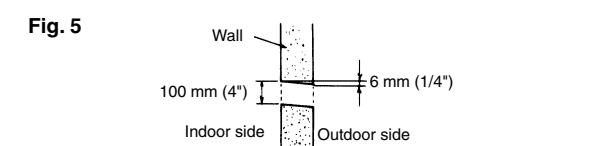

#### 2. INSTALLING THE DRAIN HOSE

Select whether the drain hose will be connected to the left or right side (Fig. 4). Insert the drain hose into the drain pan, then secure the drain hose with a nylon fastener (Fig. 7).

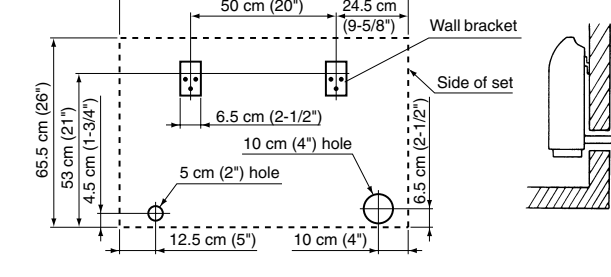

Wrap the insulation (drain hose) around the drain hose connection (Fig. 8).

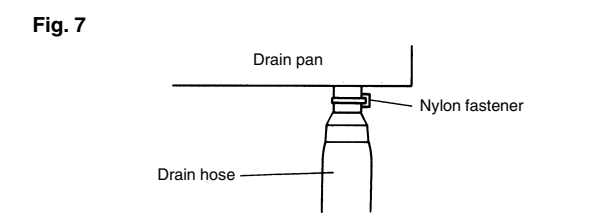

Be sure to arrange the drain hose so that it is leveled lower than the drain hose connecting part of the indoor unit.

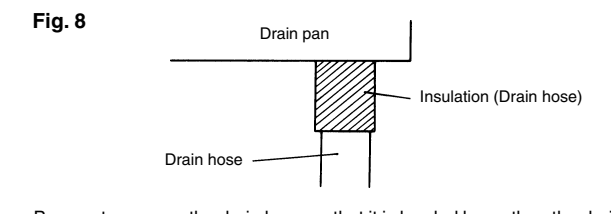

Be sure to arrange the drain hose so that it is leveled lower than the drain hose connecting part of the indoor unit.

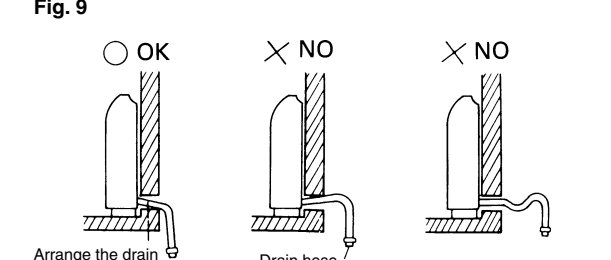

**CAUTION**  
Do not install the unit so that the drain hose side is too high. Height A should be less than 5 mm (Fig. 10).

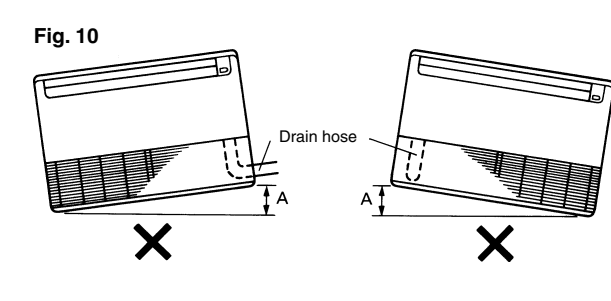

#### B. UNDER CEILING TYPE

Using the installation template, drill holes for piping and anchor bolts (for holes) (Fig. 11).

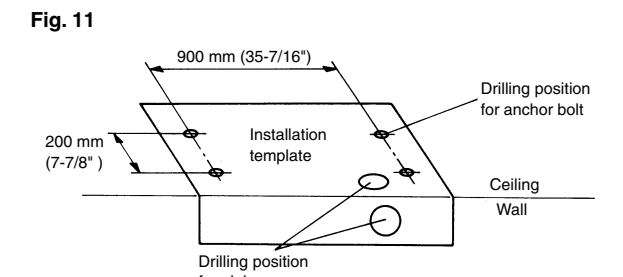

##### 1. DRILLING FOR PIPING

Select piping and drain directions (Fig. 12).

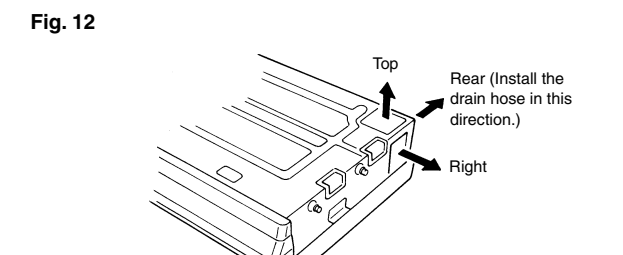

When the directions are selected, drill 80 mm (3-1/8") and 50 mm (2") or 150 mm (6") dia. hole on the wall so that the hole is tilted downward toward the outdoor for smooth water flow.

**CAUTION**  
Install the drain hose at the rear; it should not be installed on the top or right side.

When the directions are selected, drill 80 mm (3-1/8") and 50 mm (2") or 150 mm (6") dia. hole on the wall so that the hole is tilted downward toward the outdoor for smooth water flow.

##### 2. DRILLING HOLES FOR ANCHOR BOLTS AND INSTALLING THE ANCHOR BOLTS

With a concrete drill, drill four 12.7 mm (1/2") dia. holes (Fig. 14).

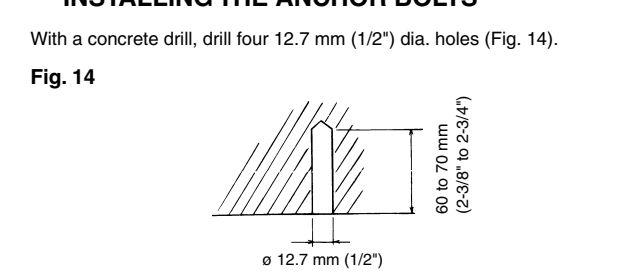

Insert the anchor bolts into the drilled holes, and drive the pins completely into the anchor bolts with a hammer (Fig. 15).

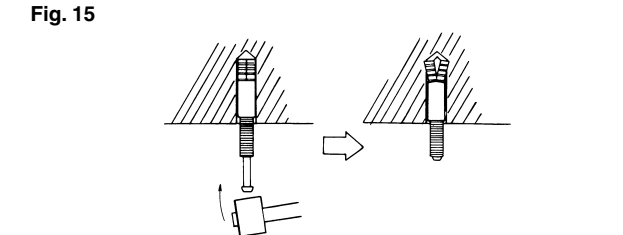

#### 3. INSTALLING BRACKETS

Install the brackets with nuts, washers and spring washers (Fig. 16).

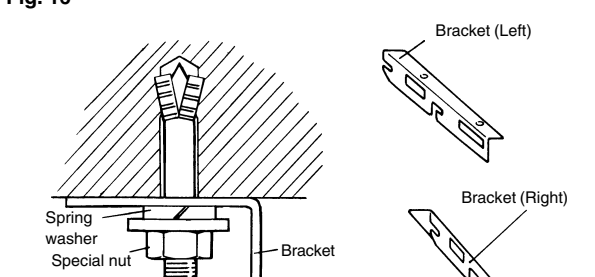

#### 4. INSTALLING INDOOR UNIT

Reset the hex bolts as shown in Fig. 17.

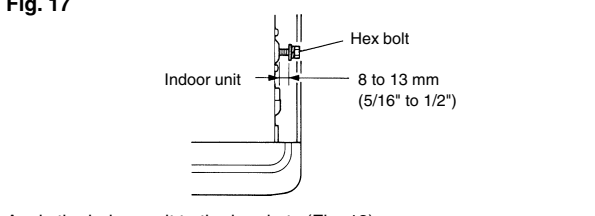

Apply the indoor unit to the brackets (Fig. 18).

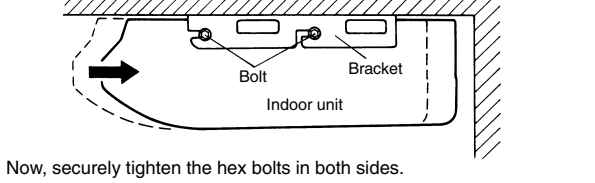

Now, securely tighten the hex bolts in both sides.

#### 5. INSTALLING THE DRAIN HOSE

Select whether the drain hose will be connected to the left or right side (Fig. 4). Insert the drain hose into the drain pan, then secure the drain hose with a nylon fastener (Fig. 7). Wrap the insulation (drain hose) around the drain hose connection (Fig. 8).

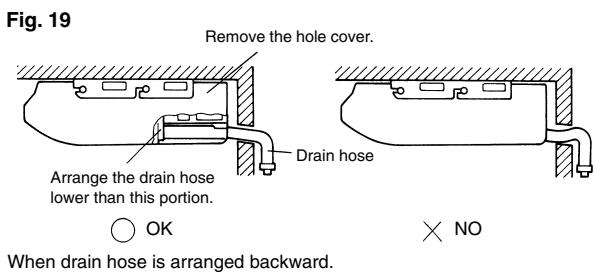

When the drain hose is arranged backward. Secure the drain hose with the VT wire (Fig. 20).

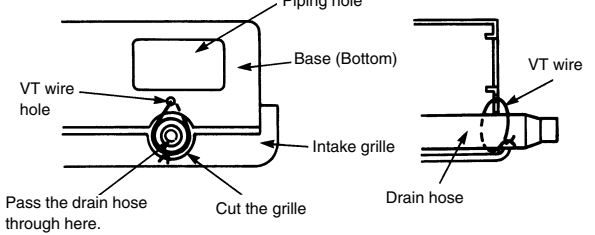

### CONNECTION PIPE REQUIREMENT

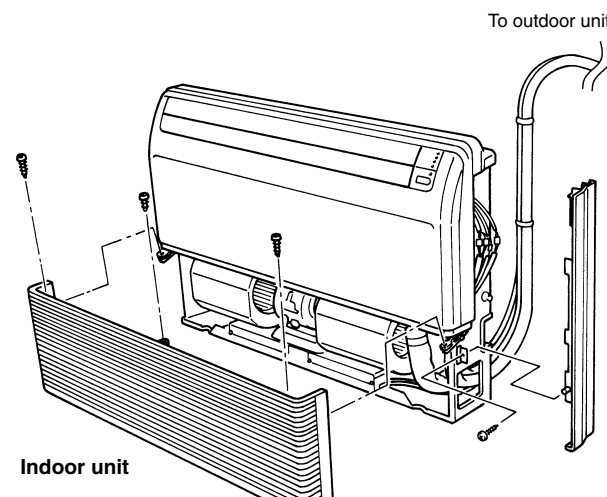

### CONNECTION PIPE REQUIREMENT

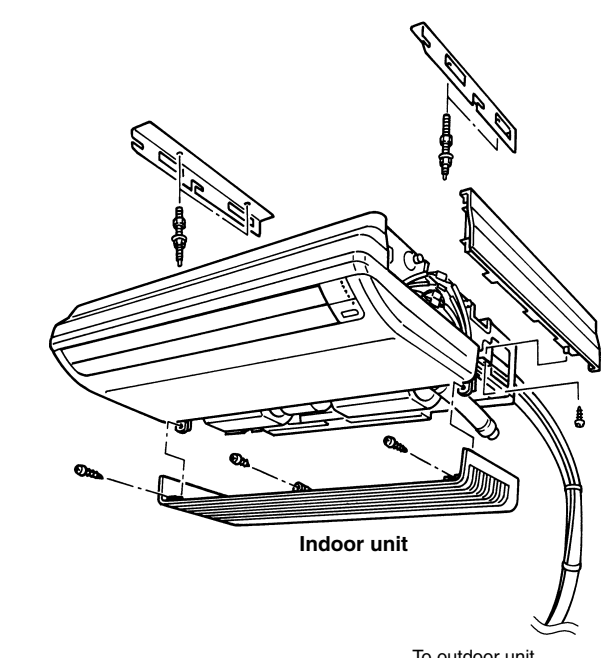

## CONNECTION PIPE REQUIREMENT

**CAUTION**

Install heat insulation around both the gas and liquid pipes. Failure to do so may cause water leaks. Use heat insulation with heat resistance above 120 °C. (Reverse cycle model only)

In addition, if the humidity level at the installation location of the refrigerant piping is expected to exceed 70%, install heat insulation around the refrigerant piping. If the expected humidity level is 70-80%, use heat insulation that is 15 mm or thicker and if the expected humidity exceeds 80%, use heat insulation that is 20 mm or thicker. If heat insulation is used that is not as thick as specified, condensation may form on the surface of the insulation. In addition, use heat insulation with heat conductivity of 0.045 W/(m·K) or less (at 20 °C).

Connect the connection pipes according to ■ CONNECTING THE PIPING in this installation instruction sheet.

MODEL	14000/18000 BTU/h model	24000 BTU/h model
Diameter	Small 6.35 mm (1/4 in.) Large 12.70 mm (1/2 in.)	9.52 mm (3/8 in.) 15.88 mm (5/8 in.)

- Use pipe with water-resistant heat insulation.
- Use pipe that can withstand a pressure of 4,150 kPa.

## ELECTRICAL REQUIREMENT

- Electric wire size:

Connection cord (mm <sup>2</sup> )	MAX.	MIN.
	2.5	1.5

- Install the disconnect device with a contact gap of at least 3 mm nearby the units. (Both indoor unit and outdoor unit)

- Always use H07RN-F or equivalent as the connection cord.

## 3 CONNECTING THE PIPING

**WARNING**

Do not use the existing piping and flare nuts. If the existing materials are used, the pressure inside the refrigerant cycle will rise and cause breakage, injury, etc. (Use the special R410A materials.)

**CAUTION**

- Do not use mineral oil on flared part. Prevent mineral oil from getting into the system as this would reduce the lifetime of the units.
- Never use piping which has been used for previous installations. Only use parts which are delivered with the unit.
- While welding the pipes, be sure to blow dry nitrogen gas through them.

#### 1. FLARING PROCESSING

- Cut the connection pipe to the necessary length with a pipe cutter.
- Hold the pipe downward so that cuttings will not enter the pipe and remove the burrs.
- Insert the flare nut (always use the flare nut attached to the indoor and outdoor units respectively) onto the pipe and perform the flare processing with a flare tool.
- Use the special R410A flare tool, or the conventional flare tool. When using the conventional flare tool, always use an allowance adjustment gauge and secure the A dimension shown in table 4.

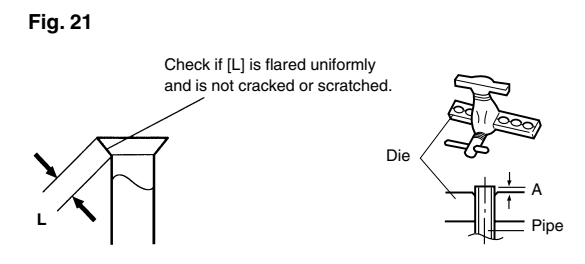

Pipe outside diameter	A (mm)
6.35 mm (1/4 in.)	0 to 0.5
9.52 mm (3/8 in.)	0 to 0.5
12.7 mm (1/2 in.)	0 to 0.5
15.88 mm (5/8 in.)	0 to 0.5

#### 2. BENDING PIPES

- When bending the pipe, be careful not to crush it.
- To prevent breaking of the pipe, avoid sharp bends. Bend the pipe with a radius of curvature of 150 mm or over.
- If the copper pipe is bend the pipe or pulled to often, it will become stiff. Do not bend the pipes more than three times at one place.

#### 3. CONNECTION PIPES

- Centering the pipe against port on the indoor unit, turn the flare nut with your hand (Fig. 22). Be sure that the small pipe is completely installed before connecting the large pipe.

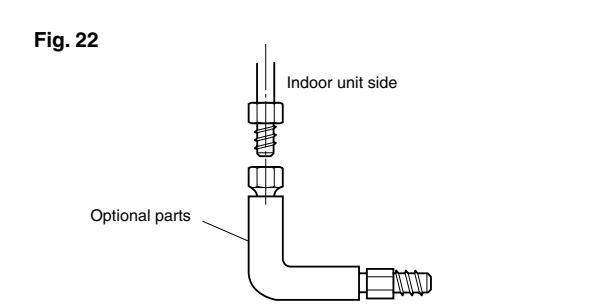

**CAUTION**

Be sure to apply the pipe against the port on the indoor unit correctly. If the centering is improper, the flare nut cannot be tightened smoothly. If the flare nut is forced to turn, the threads will be damaged.

- Install the outdoor unit wall cap (supplied with the optional installation set or procured at the site) to the wall hole pipe.
- Connect the outdoor unit and indoor unit piping.
- After matching the center of the flare surface and tightening the nut hand tight, tighten the nut to the specified tightening torque with a torque wrench.

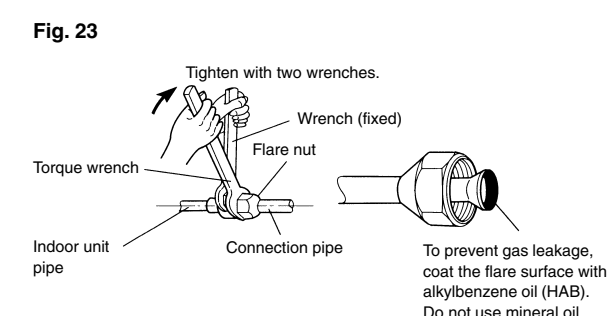

Table 5 Flare nut tightening torque

Flare nut	Tightening torque
6.35 mm (1/4 in.) dia.	14 to 18 N·m (140 to 180 kgf·cm)
9.52 mm (3/8 in.) dia.	33 to 42 N·m (330 to 420 kgf·cm)
12.7 mm (1/2 in.) dia.	50 to 62 N·m (500 to 620 kgf·cm)
15.88 mm (5/8 in.) dia.	63 to 77 N·m (630 to 770 kgf·cm)

Do not remove the cap from the connection pipe before connecting the pipe.

**CAUTION**

Be sure to connect the large pipe after connecting the small pipe completely.

#### 4. HEAT INSULATION ON THE PIPE JOINTS (INDOOR SIDE ONLY)

Put coupler heat insulator on the joints (indoor side only) (Fig. 24).

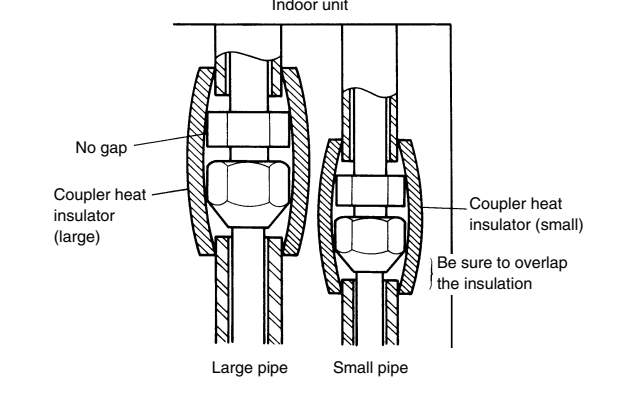

## 4 HOW TO CONNECT WIRING TO THE TERMINALS

#### A. For solid core wiring (or F-cable)

- Cut the wire end with a wire cutter or wire-cutting pliers, then strip the insulation to about 25 mm (1 5/16") of expose the solid wire.
- Using a screwdriver, remove the terminal screw(s) on the terminal board.
- Using pliers, bend the solid wire to form a loop suitable for the terminal screw.
- Shape the loop wire properly, place it on the terminal board and tighten securely with the terminal screw using a screwdriver.

#### B. For strand wiring

- Cut the wire end with a wire cutter or wire-cutting pliers, then strip the insulation to about 10 mm (3/8") of expose the strand wiring.
- Using a screwdriver, remove the terminal screw(s) on the terminal board.
- Using a round terminal fastener or pliers, securely clamp a round terminal to each stripped wire end.
- Position the round terminal wire, and replace and tighten the terminal screw using a screwdriver.

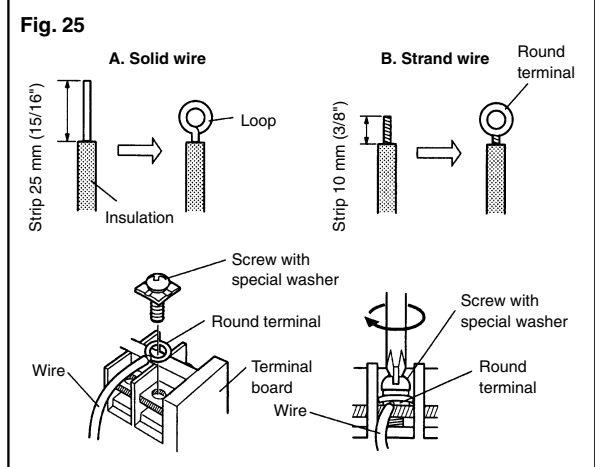

#### HOW TO FIXED CONNECTION CORD AND POWER CABLE AT THE CORD CLAMP

After passing the connection cord and power cable through the insulation tube, fasten it with the cord clamp.

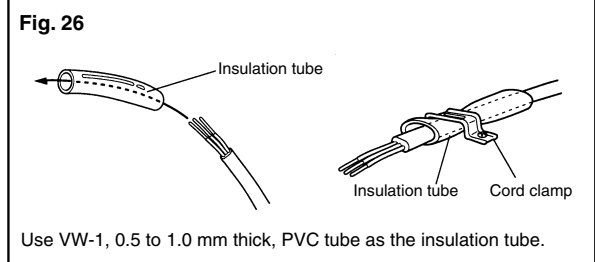

## 5 ELECTRICAL WIRING

- CAUTION**
- Match the terminal block numbers and connection cord colors with those of the outdoor unit. Erroneous wiring may cause burning of the electric parts.
  - Connect the connection cords firmly to the terminal block. Imperfect installation may cause a fire.
  - Always fasten the outside covering of the connection cord with the cord clamp. (If the insulator is chafed, electric leakage may occur.)
  - Always connect the ground wire.

### INDOOR UNIT SIDE

#### (1) Remove the electric component box.

Fig. 27

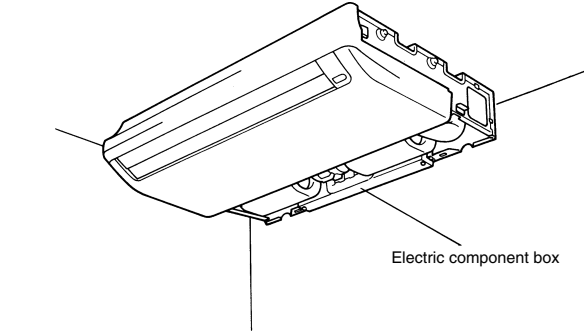
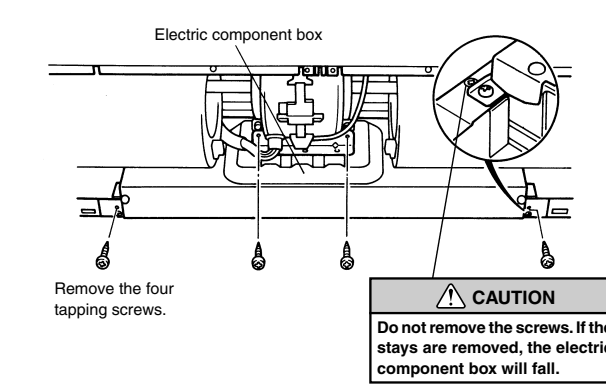
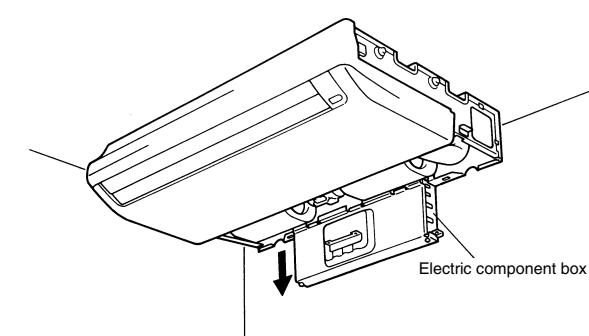

Fig. 28



#### (2) Pull out the electric component box.

Fig. 29



#### (3) Remove the electric component box cover.

Fig. 30

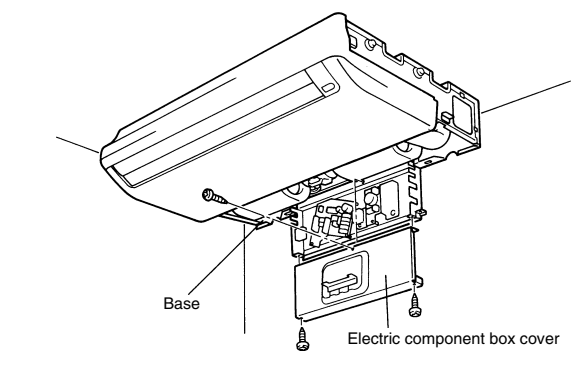

Remove the three tapping screws.

- CAUTION**
- Be careful not to pinch the lead wires between the electric component box and base.

#### (4) Wiring

- Remove the cord clamp.
- Process the end of the connection cords to the dimensions shown in Fig. 31.
- Connect the end of the connection cord fully into the terminal block.

Fig. 31

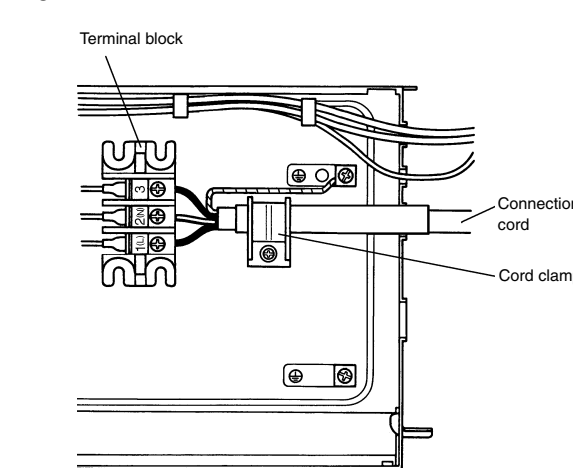

## 6 TEST RUNNING

- CAUTION**
- Always turn on the power 4 hours prior to the start of the operation in order to ensure compressor protection.
- Perform test operation and check items (1) to (5) below.
  - For the operation method, refer to the operating manual.
  - The outdoor unit may not run, depending on the room temperature. In this case, the 'TEST RUN' signal is received during air conditioner operation (use a metallic object to short the two metal contacts under the battery compartment lid and send the 'TEST RUN' signal from the remote control unit).

Fig. 32

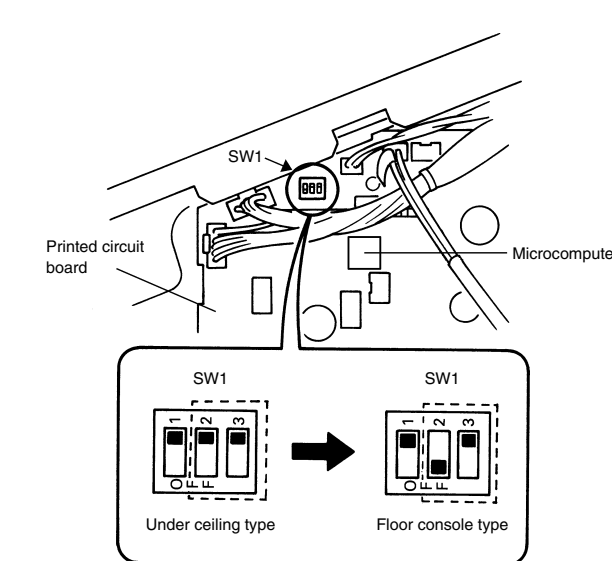

Remove the three tapping screws.

- CAUTION**
- Be careful not to pinch the lead wires between the electric component box and base.

#### (4) Wiring

- Remove the cord clamp.
- Process the end of the connection cords to the dimensions shown in Fig. 31.
- Connect the end of the connection cord fully into the terminal block.

Fig. 31



## 7 MOUNT THE COVER PLATE AND THE INTAKE GRILLE

- CAUTION**
- Always turn on the power 4 hours prior to the start of the operation in order to ensure compressor protection.

- Perform test operation and check items (1) to (5) below.
- For the operation method, refer to the operating manual.
- The outdoor unit may not run, depending on the room temperature. In this case, the 'TEST RUN' signal is received during air conditioner operation (use a metallic object to short the two metal contacts under the battery compartment lid and send the 'TEST RUN' signal from the remote control unit).

Fig. 33

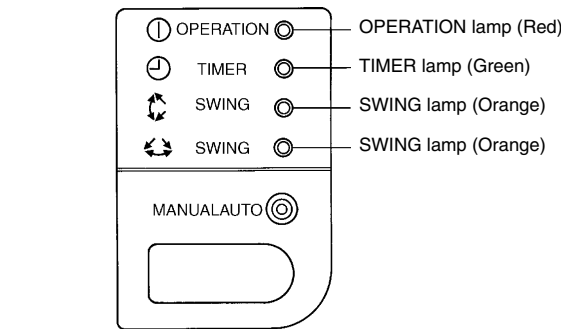
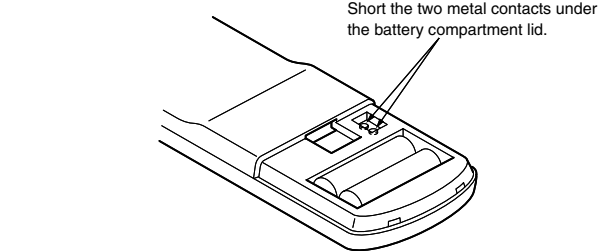

Operation can be checked by lighting and flashing of the display section OPERATION and TIMER lamps. Perform judgement in accordance with the following.

#### Test running

When the air conditioner is run by pressing the remote control unit TEST RUN button, the OPERATION and TIMER lamps flash slowly at the same time.

- CAUTION**
- If the indoor units are connected with a capacity outside of the recommended range, the indoor units will not function and the indoor unit lamps will flash in the following error patterns.
- OPERATION LAMP (red)...flashes fast  
SWING LAMP (orange)...flashes 4 times slowly and goes off repeatedly

## 8 REMOTE CONTROL UNIT INSTALLATION

- CAUTION**
- The OPERATION, TIMER and SWING lamps operate as follows (Table 6) according to the error contents.

Error contents	Error display		
	OPERATION (RED)	TIMER (GREEN)	SWING (ORANGE)
Indoor unit circuit board error	○	○	—
Indoor unit room temperature sensor wire opened	2 times ●	○	—
Indoor unit room temperature sensor wire short circuited	2 times ●	○	○
Indoor unit piping sensor wire opened	3 times ●	○	—
Indoor unit piping sensor short circuited	3 times ●	○	○
Indoor unit fan error	6 times ●	○	—
Outdoor unit circuit board error	5 times ●	○	—
Miswiring between outdoor unit and indoor unit	5 times ●	○	—
Outdoor unit discharge temperature sensor error	○	5 times ●	—
Outdoor unit piping sensor error	○	3 times ●	—
Outdoor unit outdoor temperature sensor error	○	4 times ●	—

○ : Fast flashing ● : Slow flashing — : Off

#### CHECK ITEMS

- Is operation of each button on the remote control unit normal?
- Does each lamp light normally?
- Do not air flow direction louvers operate normally?
- Is the drain normal?
- Is there any abnormal noise and vibration during operation?

- Do not operate the air conditioner in the test running state for a long time.
- For the operation method, refer to the operating manual and perform operation check.

## 8 REMOTE CONTROL UNIT INSTALLATION

- CAUTION**
- Check that the indoor unit correctly receives the signal from the remote control unit, then install the remote control unit holder.
  - Select the remote control unit holder selection site by paying careful attention to the following: Avoid places in direct sunlight. Select a place that will not be affected by the heat from a stove, etc.

### 1. REMOTE CONTROL UNIT HOLDER INSTALLATION

- Install the remote control unit with a distance of 7 m between the remote control unit and the photocell as the criteria. However, when installing the remote control unit, check that it operates positively.
- Install the remote control unit holder to a wall, pillar, etc. with the tapping screw (Fig. 39).

Fig. 39

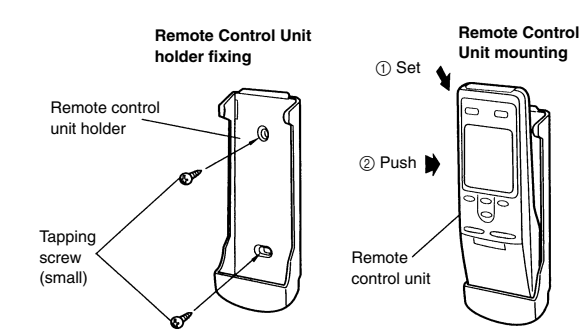

### 2. SWITCHING REMOTE CONTROL UNIT SIGNAL CODES

- Air conditioner settings
- Confirm the setting of the remote control unit signal code and the printed circuit board setting. If these are not confirmed, the remote control unit cannot be used to operate for the air conditioner.

Jumper wire		Remote control unit signal code
JM2	JM3	
Connect	Connect	A (Primary setting)
Connect	Disconnect	B
Disconnect	Connect	C
Disconnect	Disconnect	D

Fig. 40

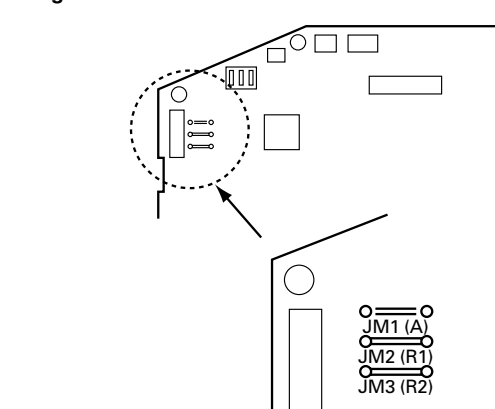

- Remote control unit settings
- Press the START/STOP button and display only the clock.

Fig. 41

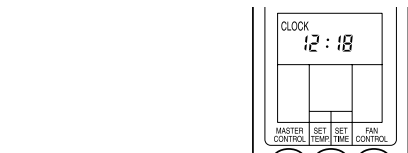

- Press the MASTER CONTROL button continuously for more than five seconds to display the current signal code.

Fig. 42

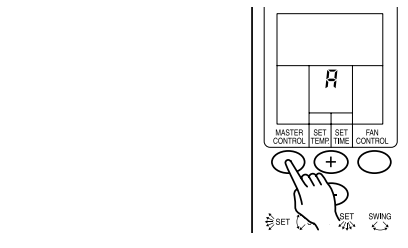

- Change the signal code with the ◁ ▷ button (A - B - C - D).

Fig. 43

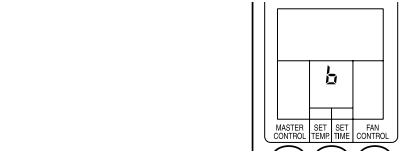

- Press the MASTER CONTROL button again to return to the clock display and change the signal code.

## 9 CUSTOMER GUIDANCE

Explain the following to the customer in accordance with the operating manual:

- Starting and stopping method, operation switching, temperature adjustment, timer, air flow switching, and other remote control unit operations.
- Air filter removal and cleaning, and how to use the air louvers.
- Give the operating and installation manuals to the customer.
- If the signal code is changed, explain to the customer how it changed (the system returns to signal code A when the batteries in the remote control unit are replaced).