

AIR CONDITIONER

**Floor / Ceiling type**

# DESIGN & TECHNICAL MANUAL

---

---

SINGLE  
INDOOR

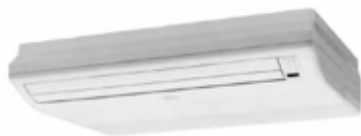

AB\*G18LVTB  
AB\*G24LVTA

---

OUTDOOR



AO\*G18LALL  
AO\*G24LALA

---

**FUJITSU GENERAL LIMITED**

# 1. INDOOR UNIT

---

**FLOOR / CEILING TYPE :**

**AB\*G18LVTB**

**AB\*G24LVTA**

# CONTENTS

---

## 1. INDOOR UNIT

---

<b>1. FEATURES</b> .....	01 - 01
<b>2. WIRELESS REMOTE CONTROLLER</b> .....	01 - 03
<b>3. SPECIFICATIONS</b> .....	01 - 05
<b>4. DIMENSIONS</b> .....	01 - 07
<b>5. WIRING DIAGRAMS</b> .....	01 - 09
<b>6. CAPACITY TABLE</b> .....	01 - 10
6-1. COOLING CAPACITY .....	01 - 10
6-2. HEATING CAPACITY .....	01 - 11
<b>7. FAN PERFORMANCE</b> .....	01 - 12
7-1. AIR VELOCITY DISTRIBUTION .....	01 - 12
7-2. AIRFLOW .....	01 - 16
<b>8. OPERATION NOISE</b> .....	01 - 18
8-1. NOISE LEVEL CURVE (SOUND PRESSURE).....	01 - 18
8-2. SOUND LEVEL CHECK POINT .....	01 - 19
<b>9. ELECTRIC CHARACTERISTICS</b> .....	01 - 20
<b>10. SAFETY DEVICES</b> .....	01 - 21
<b>11. EXTERNAL INPUT &amp; OUTPUT</b> .....	01 - 22
11-1. EXTERNAL INPUT .....	01 - 22
11-2. EXTERNAL OUTPUT .....	01 - 23
<b>12. FUNCTION SETTINGS</b> .....	01 - 24
12-1. INDOOR UNIT .....	01 - 24
12-2. INDOOR UNIT (Setting by remote controller) .....	01 - 25
<b>13. OPTIONAL PARTS</b> .....	01 - 29
13-1. CONTROLLER .....	01 - 29
13-2. OTHERS .....	01 - 29

# 1. FEATURES

## ■ MODEL

AB\*G18LVTB / AO\*G18LALL  
AB\*G24LVTA / AO\*G24LALA



## ■ FEATURES

### ● Energy efficiency class

	MODEL	
	AB*G18LVTB	AB*G24LVTA
Cooling	A++	A+
Heating	A+	A

### ● Flexible installation

Example for floor installation



Example for ceiling installation



### ● Easy installation

Main work settings can be done easily from the remote controller at installation

**Main work settings**

- High ceiling setting
- Auto restart
- Temperature adjustment when cooling / heating

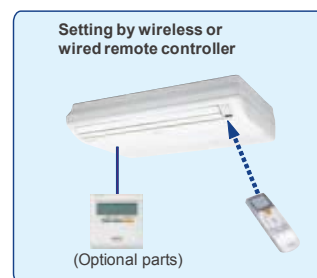

### ● Double auto swing

A combination of right/left and up/down directional swing allows 3-dimensional air direction control

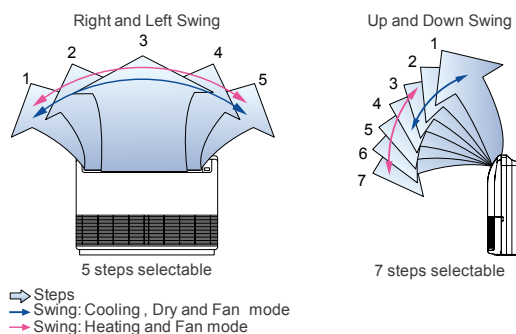

## ● 10°C HEAT Operation \*Only available with Wireless RC.

The room temperature can be set to go no lower than 10°C, thus ensuring that the room does not get too cold when not occupied

Caution)

- When the room temperature is higher than 10°C, "10°C HEAT" operation will not start. Operation starts and maintains the room temperature at 10°C when the temperature drops below 10°C.
- When "10°C HEAT" operation stops, the room set temperature quickly returns to the preset temperature.

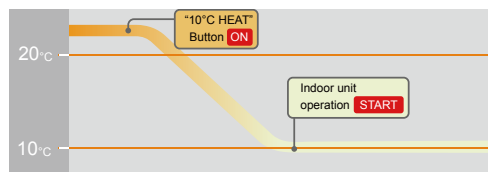

## ● Economy operation

The power consumption can be reduced.

## 2. WIRELESS REMOTE CONTROLLER

### ■ FEATURES



- \* 4 mode timer setup available (ON / OFF / PROGRAM / SLEEP).
- \* Easy operation.
- \* Easy to change signal code (max. 4 units) by button operation.

#### ● Simple function setting

Setting of the air conditioner selection function is performed by remote controller.

#### ● Built-in timers

Select from four different timer programs (ON / OFF / PROGRAM / SLEEP).

#### ● Program timer

The program timer operates the on and off timer once within a 24 hour period.

#### ● Sleep timer

The sleep timer function automatically corrects the temperature thermostat setting according to the time setting to prevent excessive cooling and heating while sleeping.

##### Cooling operation/dry operation

When the sleep timer is set, the set temperature automatically rises 1°C every hour. The set temperature can rise up to a maximum of 2°C.

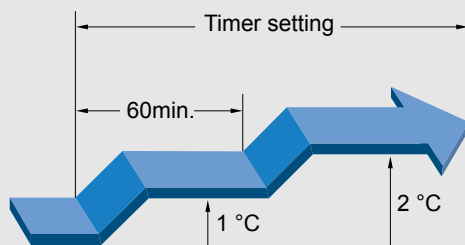

##### Heating operation

When the sleep timer is set, the set temperature automatically drops 1°C every 30 minutes. The set temperature can drop to a maximum of 4°C.

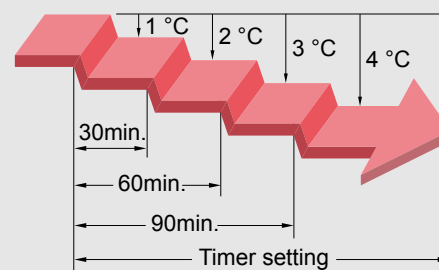

#### ● Switching remote controller signal code

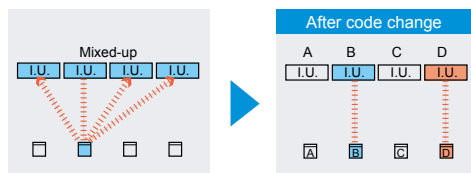

- Code selector switch eliminates unit being wrongly switched.  
(Up to 4 codes can be set.)

\*I.U.=Indoor unit

## FUNCTIONS

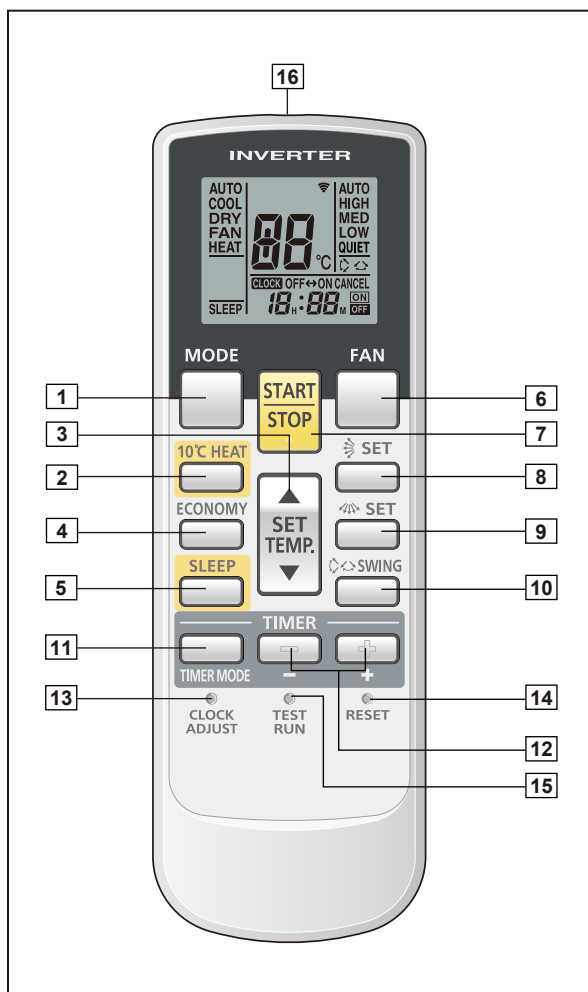

- 1 MODE button  
Selects the operating mode (AUTO, COOL, DRY, FAN, HEAT). /Start / end R.C. signal code change. (Max 4 types)
- 2 10°C HEAT button
- 3 SET TEMP. button ( ▲ / ▼ )  
Sets the indoor temp./ Sets R.C. signal code.
- 4 ECONOMY button
- 5 SLEEP button  
Pressed to select sleep timer.
- 6 FAN button  
Selects the fan speed (AUTO, HIGH, MED, LOW, QUIET).
- 7 START/STOP button  
Pressed to start and stop operation.
- 8 SET button (Vertical)  
Air flow direction vertical set button.
- 9 SET button (Horizontal)  
Air flow direction horizontal set button.
- 10 SWING button  
Air flow direction swing button.
- 11 TIMER MODE button  
Pressed to select the timer mode. (OFF TIMER, ON TIMER, PROGRAM TIMER, TIMER RESET)
- 12 TIMER SET ( ⊞ / ⊞ ) button  
Sets the current time and on-off time.
- 13 CLOCK ADJUST button  
Sets the current time.
- 14 RESET button  
Used when replacing batteries.
- 15 TEST RUN button  
Used when testing the air conditioner after installation.

Display panel

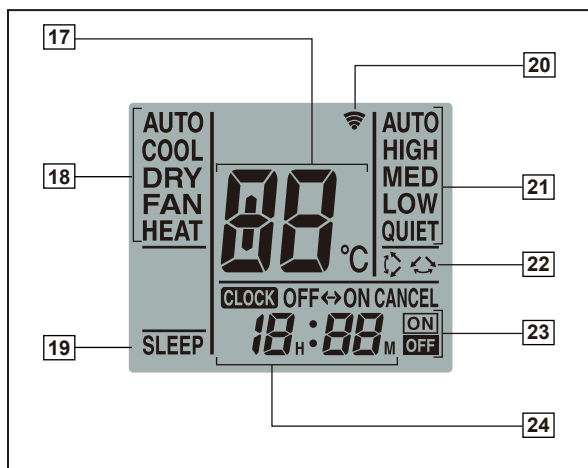

- 16 Signal transmitter
- 17 Temperature set display
- 18 Operating mode display
- 19 Sleep display
- 20 Transmit indicator
- 21 Fan speed display
- 22 Swing display
- 23 Timer mode display
- 24 Clock display

Note: Functions will be different due to type of indoor unit.  
For details, please see operation manual.

## SPECIFICATION

SIZE	(H × W × D mm)	170 × 56 × 19
WEIGHT	(g)	85 (w/o batteries)
ACCESSORY		Holder

### 3. SPECIFICATIONS

Type				FLOOR / CEILING MODEL			
				INVERTER HEATPUMP			
Model name				AB*G18LVTB	AB*G24LVT		
Power source				230V ~ 50Hz			
Available voltage range				198 - 264V ~ 50Hz			
Capacity	Cooling	Rated	kW	5.20	6.80		
			Btu/h	17700	23200		
		Min - Max	kW	0.90 - 5.90	0.90 - 8.00		
	Heating	Rated	Btu/h	3100 - 20100	3100 - 27300		
			kW	6.00	8.00		
		Min - Max	kW	0.90 - 7.50	0.90 - 9.10		
Input power	Cooling	Rated	kW	1.62	2.21		
				Max	2.04	2.85	
	Heating	Rated		1.66	2.26		
				Max	2.83	3.19	
Current	Cooling	Rated	A	7.2	9.7		
	Heating	Rated		7.4	9.9		
EER	Cooling		kW/kW	3.21	3.08		
COP	Heating			3.61	3.54		
Moisture removal			l/h (pints/h)	2.0 (3.5)	2.9 (5.1)		
Maximum operating current *		Cooling	A	9.0	12.0		
		Heating		12.5	13.5		
Fan	Airflow rate	Cooling	m <sup>3</sup> /h	High	780	980	
				Med	700	820	
				Low	560	680	
		Heating		Quiet	500	540	
				High	780	980	
				Med	700	820	
	Type × Q'ty				Sirocco × 2		
		Motor output		W	80		
		Sound pressure level	Cooling	High	dB (A)	44 (Floor console), 43 (Under ceiling)	
				Med		45 (Floor console), 44 (Under ceiling)	
Low	35 (Floor console), 34 (Under ceiling)						
Quiet	32 (Floor console), 31 (Under ceiling)						
Heating	High		44 (Floor console), 43 (Under ceiling)				
	Med		45 (Floor console), 44 (Under ceiling)				
	Low		35 (Floor console), 34 (Under ceiling)				
	Quiet		32 (Floor console), 31 (Under ceiling)				
Heat exchanger type	Dimensions (H × W × D)		mm	252 × 800 × 39.9			
	Fin pitch			1.30			
	Rows × Stages			3 × 12			
	Pipe type			Copper tube			
	Fin type			Aluminium			
Enclosure	Material		ABS				
	Colour		WHITE (Approximate colour of MUNSELL N9.25 /)				
Dimensions (H × W × D)	Net		mm	199 × 990 × 655			
	Gross			320 × 1150 × 790			
Weight	Net		kg	27			
	Gross			36			
Connection pipe	Size	Liquid	mm	Ø6.35 (Ø1/4 in.)			
		Gas		Ø12.70 (Ø1/2 in.)	Ø15.88 (Ø5/8 in.)		
	Method			Flare			
Operation range	Cooling	°C	18 to 32				
		%RH	80 or less				
	Heating	°C	16 to 30				
Remote controller type				Wireless [Wired (option)]			
Drain pipe	Material		Hard PVC				
	Size		mm				
				VP25 [Ø25 (I.D.), Ø32 (O.D.)]			

Note :  
 Specifications are based on the following conditions.  
 Cooling : Indoor temperature of 27° CDB / 19° CWB, and outdoor temperature of 35° CDB / 24° CWB.  
 Heating : Indoor temperature of 20° CDB / 15° CWB, and outdoor temperature of 7° CDB / 6° CWB.  
 Pipe length : 5 m, Height difference : 0 m. (Outdoor unit - Indoor unit)  
 The protective function might work when using outside the operation range.  
 \*: The maximum current is the maximum value when operated within the operation range.



Model name		AB*G18LVTB		AB*G24LVTA	
Energy efficiency class	Cooling	A++		A+	
	Heating (Average)	A+		A	
Pdesign	Cooling	kW	5.2 (35°C)	6.8 (35°C)	
	Heating (Average)		5.2 (-10°C)	6.0 (-10°C)	
SEER	Cooling	kWh/kWh	6.10	5.60	
SCOP	Heating (Average)		4.00	3.90	
Annual energy consumption	QCE	kWh/a	298	425	
	QHE (Average)		1819	2150	
Sound power level	Cooling	High	dB (A)	57	
	Heating			61	

# 4. DIMENSIONS

## MODEL: AB\*G18LVTB, AB\*G24LVTA

(Unit : mm)

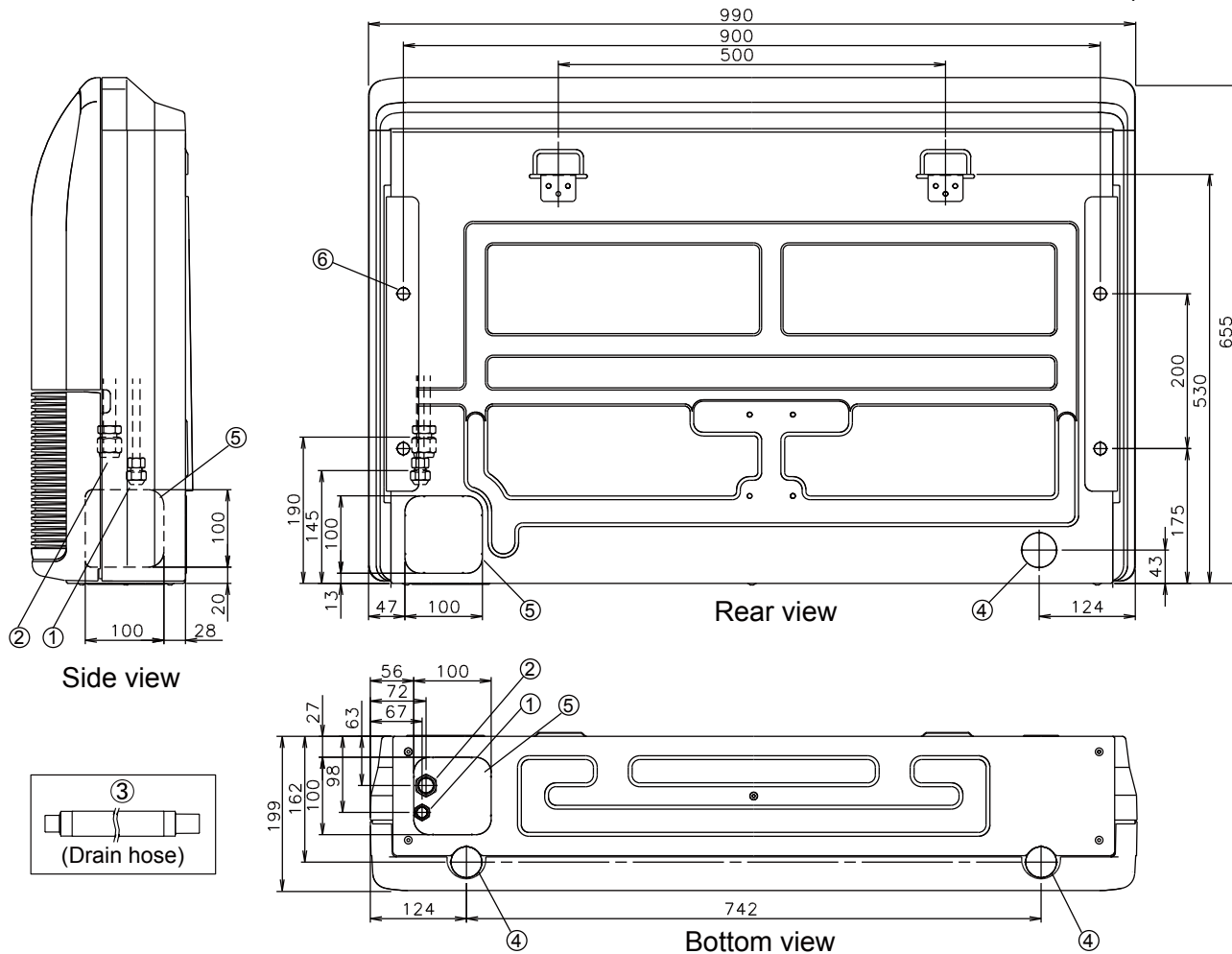

When installing set to wall install the accessory wall bracket at the position as shown in the figure, and mount the set to it.

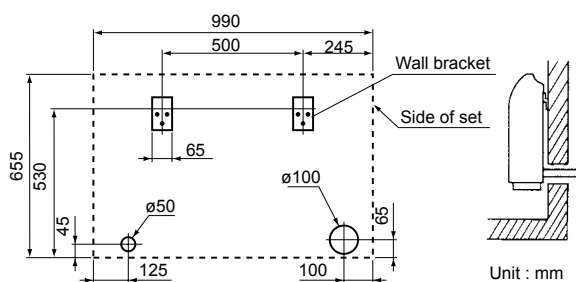

		AB*G18LVTB	AB*G24LVTA
①	Refrigerant pipe flare connection	Liquid	ø 6.35 mm (ø 1/4 in.)
②		Gas	ø 12.70 mm (ø 1/2 in.) / ø 15.88 mm (ø 5/8 in.)
③	Drain hose connection	Drain hose	VP25 [Ø25 (I.D.), Ø32 (O.D.)]
④	Knock out hole	Drain outlet	-
⑤		Pipe outlet	-
⑥	Hole for lifting bolt	-	Use M10 screw bolt

# ■ INSTALLATION PLACE

(Unit : mm)

## ● Floor type

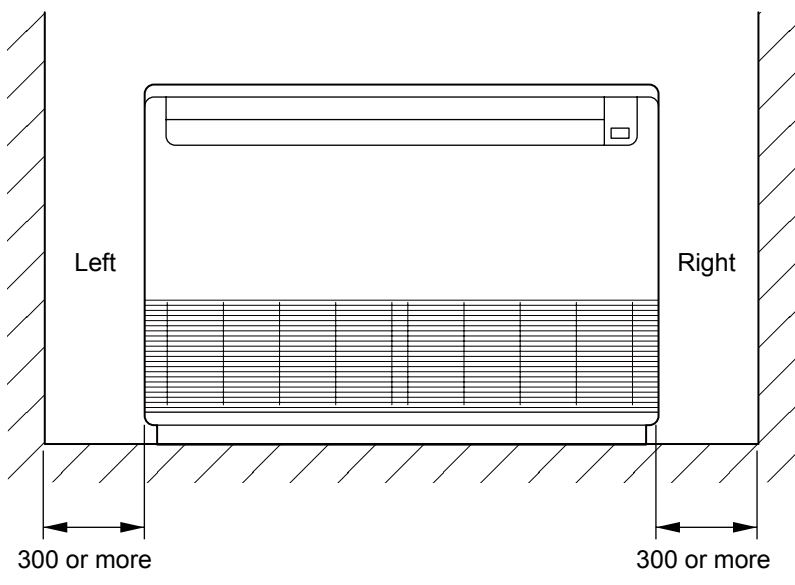

## ● Ceiling type

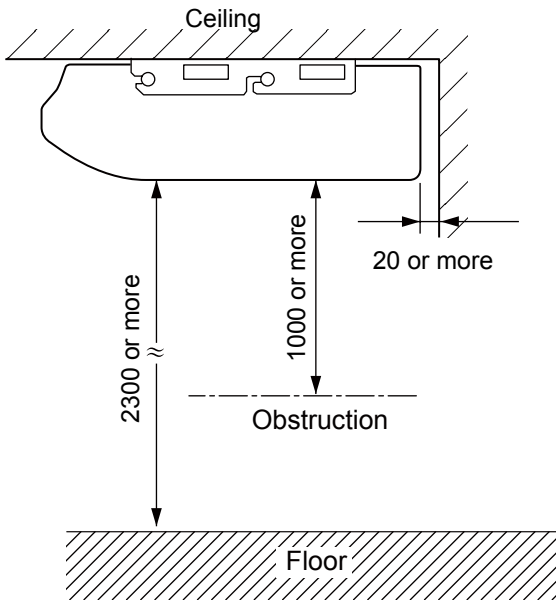
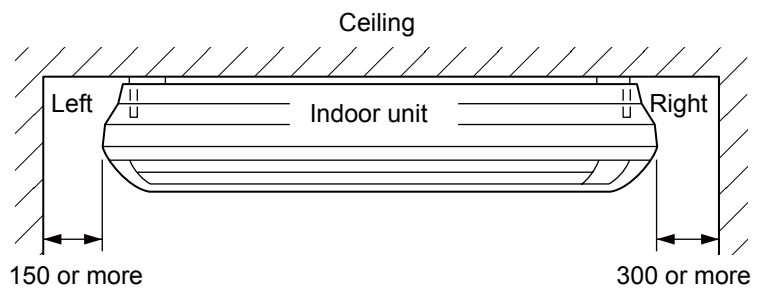

# 5. WIRING DIAGRAMS

## MODEL: AB\*G18LVTB, AB\*G24LVTA

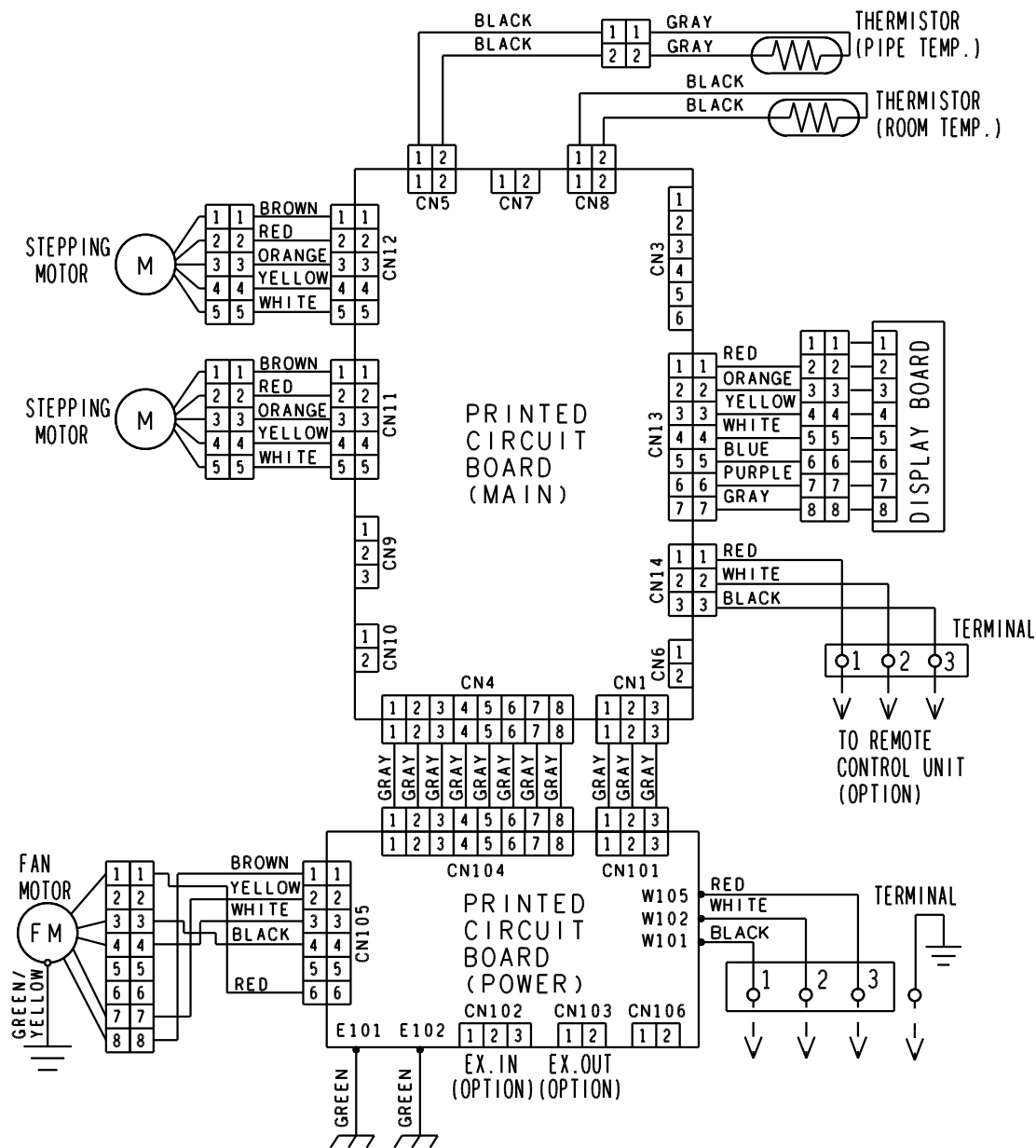

# 6. CAPACITY TABLE

## 6-1. COOLING CAPACITY

This table is created using the maximum capacity.

### MODEL: AB\*G18LVTB

AFR	13.0
-----	------

		Indoor temperature																						
		18			21			23			25			27			29			32				
		12			15			16			18			19			21			23				
Outdoor temperature	°CDB	TC	SHC	IP	TC	SHC	IP	TC	SHC	IP	TC	SHC	IP	TC	SHC	IP	TC	SHC	IP	TC	SHC	IP		
	-10	4.35	3.28	0.39	4.84	3.30	0.40	5.01	3.59	0.40	5.34	3.60	0.40	5.50	3.89	0.40	5.83	3.88	0.41	6.17	4.13	0.41		
	0	4.26	3.24	0.46	4.74	3.26	0.46	4.90	3.54	0.47	5.23	3.56	0.47	5.39	3.84	0.47	5.71	3.83	0.48	6.04	4.07	0.48		
	5	4.14	3.18	0.57	4.61	3.20	0.58	4.77	3.48	0.58	5.08	3.49	0.59	5.24	3.77	0.59	5.55	3.76	0.60	5.86	4.00	0.60		
	10	4.00	3.12	0.68	4.45	3.14	0.69	4.61	3.41	0.70	4.91	3.42	0.70	5.06	3.70	0.71	5.37	3.68	0.71	5.67	3.92	0.72		
	15	4.04	3.14	0.59	4.50	3.16	0.60	4.65	3.43	0.61	4.95	3.44	0.61	5.11	3.72	0.62	5.41	3.70	0.62	5.72	3.94	0.63		
	20	5.16	3.63	1.28	5.75	3.65	1.30	5.95	3.97	1.31	6.34	3.98	1.32	6.54	4.30	1.33	6.93	4.28	1.34	7.32	4.56	1.35		
	25	4.94	3.54	1.43	5.51	3.57	1.46	5.70	3.88	1.46	6.07	3.89	1.48	6.26	4.20	1.49	6.63	4.18	1.50	7.01	4.46	1.52		
	30	4.71	3.45	1.59	5.25	3.47	1.61	5.43	3.78	1.62	5.78	3.79	1.64	5.96	4.09	1.65	6.32	4.07	1.66	6.68	4.34	1.68		
	35	4.66	3.43	1.88	5.19	3.45	1.91	5.37	3.75	1.92	5.72	3.76	1.94	5.90	4.06	1.95	6.25	4.04	1.97	6.61	4.31	1.99		
	40	3.53	2.90	1.34	3.93	2.92	1.36	4.06	3.18	1.36	4.33	3.19	1.38	4.46	3.44	1.38	4.73	3.43	1.40	5.00	3.65	1.41		
46	2.50	2.46	1.01	2.79	2.47	1.02	2.88	2.69	1.03	3.07	2.69	1.04	3.17	2.91	1.05	3.36	2.90	1.06	3.55	3.09	1.07			

### MODEL: AB\*G24LVTA

AFR	15.3
-----	------

		Indoor temperature																						
		18			21			23			25			27			29			32				
		12			15			16			18			19			21			23				
Outdoor temperature	°CDB	TC	SHC	IP	TC	SHC	IP	TC	SHC	IP	TC	SHC	IP	TC	SHC	IP	TC	SHC	IP	TC	SHC	IP		
	-10	5.79	4.65	0.60	6.46	4.67	0.61	6.68	5.08	0.61	7.12	5.10	0.62	7.34	5.51	0.62	7.78	5.48	0.63	8.22	5.84	0.63		
	0	5.69	4.59	0.64	6.34	4.62	0.65	6.55	5.02	0.65	6.98	5.04	0.66	7.20	5.44	0.66	7.63	5.42	0.67	8.06	5.77	0.68		
	5	5.49	4.49	0.78	6.12	4.52	0.79	6.33	4.91	0.79	6.74	4.93	0.80	6.95	5.32	0.81	7.37	5.30	0.81	7.79	5.64	0.82		
	10	5.28	4.38	0.91	5.88	4.40	0.92	6.08	4.79	0.93	6.48	4.80	0.94	6.68	5.19	0.94	7.08	5.17	0.95	7.48	5.50	0.96		
	15	5.39	4.44	0.76	6.01	4.47	0.77	6.21	4.85	0.77	6.62	4.87	0.78	6.83	5.26	0.79	7.24	5.24	0.79	7.65	5.58	0.80		
	20	6.85	5.22	1.61	7.63	5.25	1.64	7.89	5.71	1.64	8.41	5.73	1.66	8.67	6.18	1.67	9.19	6.16	1.69	9.71	6.56	1.70		
	25	6.53	5.04	1.80	7.27	5.07	1.82	7.52	5.51	1.83	8.01	5.52	1.85	8.26	5.97	1.86	8.76	5.94	1.88	9.25	6.33	1.90		
	30	6.18	4.86	2.00	6.89	4.88	2.03	7.12	5.31	2.04	7.59	5.33	2.06	7.83	5.75	2.07	8.30	5.73	2.09	8.77	6.10	2.11		
	35	6.32	4.93	2.47	7.04	4.96	2.51	7.28	5.39	2.52	7.76	5.41	2.55	8.00	5.84	2.56	8.48	5.82	2.59	8.96	6.20	2.61		
	40	5.21	4.34	2.05	5.81	4.37	2.08	6.01	4.75	2.09	6.40	4.77	2.11	6.60	5.15	2.12	7.00	5.13	2.14	7.39	5.46	2.16		
46	3.77	3.62	1.55	4.20	3.64	1.57	4.35	3.96	1.58	4.63	3.97	1.60	4.78	4.29	1.61	5.06	4.27	1.62	5.35	4.55	1.64			

AFR : Air Flow Rate (m<sup>3</sup>/min)  
 TC : Total Capacity (kW)  
 SHC : Sensible Heat Capacity (kW)  
 IP : Input Power(kW)

## 6-2. HEATING CAPACITY

This table is created using the maximum capacity.

### ■ MODEL: AB\*G18LVTB

AFR	13.0
-----	------

		°CDB	Indoor temperature									
			16		18		20		22		24	
Outdoor temperature	°CDB	°CWB	TC	IP	TC	IP	TC	IP	TC	IP	TC	IP
	-15	-16	5.25	2.15	5.13	2.20	5.00	2.24	4.88	2.29	4.75	2.33
	-10	-11	5.90	2.27	5.76	2.32	5.62	2.37	5.48	2.42	5.34	2.46
	-5	-7	6.57	2.40	6.41	2.45	6.26	2.50	6.10	2.55	5.94	2.60
	0	-2	7.46	2.57	7.28	2.62	7.10	2.68	6.93	2.73	6.75	2.78
	5	3	8.18	2.65	7.98	2.70	7.79	2.76	7.59	2.81	7.40	2.83
	7	6	7.88	2.26	7.69	2.30	7.50	2.35	7.31	2.40	7.13	2.44
	10	8	8.15	2.31	7.96	2.35	7.77	2.40	7.57	2.45	7.38	2.50
	15	10	7.70	1.97	7.52	2.01	7.33	2.05	7.15	2.09	6.97	2.13
	20	15	7.23	1.58	7.06	1.62	6.88	1.65	6.71	1.68	6.54	1.72
24	18	7.43	1.59	7.25	1.62	7.07	1.65	6.90	1.68	6.72	1.72	

### ■ MODEL: AB\*G24LVTA

AFR	15.3
-----	------

		°CDB	Indoor temperature									
			16		18		20		22		24	
Outdoor temperature	°CDB	°CWB	TC	IP	TC	IP	TC	IP	TC	IP	TC	IP
	-15	-16	6.15	2.70	6.00	2.76	5.86	2.82	5.71	2.87	5.57	2.93
	-10	-11	6.93	2.87	6.76	2.93	6.60	2.99	6.43	3.05	6.27	3.11
	-5	-7	7.64	2.86	7.46	2.91	7.28	2.97	7.10	3.03	6.92	3.09
	0	-2	8.59	2.84	8.39	2.90	8.18	2.96	7.98	3.01	7.77	3.07
	5	3	9.55	2.86	9.32	2.91	9.09	2.97	8.86	3.03	8.64	3.09
	7	6	9.56	2.54	9.33	2.60	9.10	2.65	8.87	2.70	8.65	2.76
	10	8	9.86	2.55	9.63	2.60	9.39	2.65	9.16	2.71	8.92	2.76
	15	10	8.97	1.99	8.75	2.03	8.54	2.07	8.33	2.12	8.11	2.16
	20	15	8.22	1.54	8.03	1.57	7.83	1.60	7.64	1.63	7.44	1.66
24	18	8.52	1.54	8.32	1.57	8.12	1.60	7.91	1.63	7.71	1.66	

AFR : Air Flow Rate (m<sup>3</sup>/min)  
TC : Total Capacity (kW)  
IP : Input Power(kW)

# 7. FAN PERFORMANCE

## 7-1. AIR VELOCITY DISTRIBUTION

### MODEL: AB\*G18LVTB (UNDER CEILING)

Conditions  
Fan speed : High  
Operation mode : Fan

Top view  
Vertical flap : Up  
Horizontal flap : Center

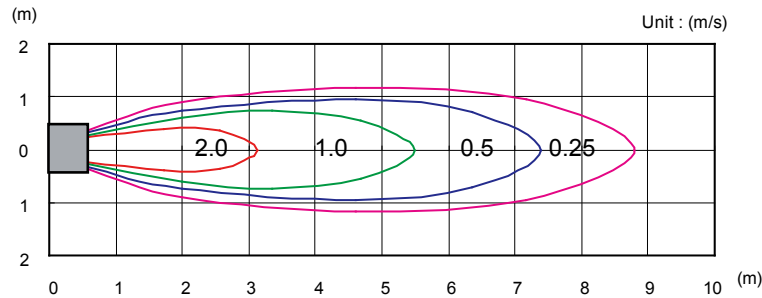

Top view  
Vertical flap : Up  
Horizontal flap : Right & Left

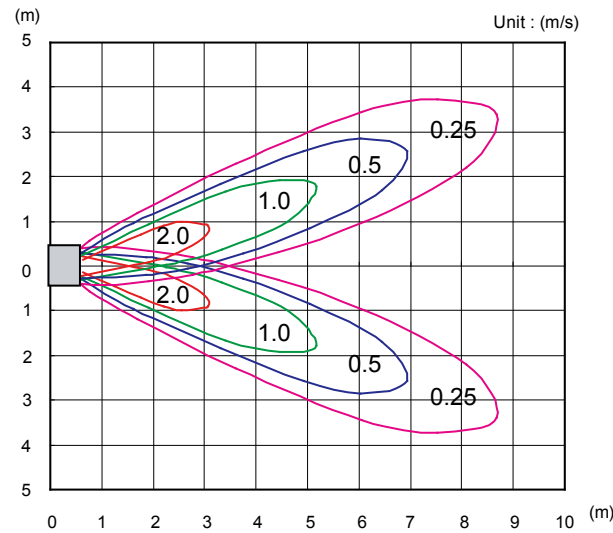

Side view  
Vertical flap : Up  
Horizontal flap : Center

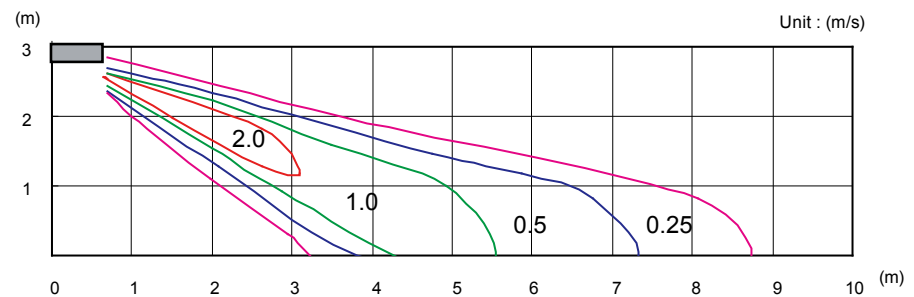

Side view  
Vertical flap : Center  
Horizontal flap : Center

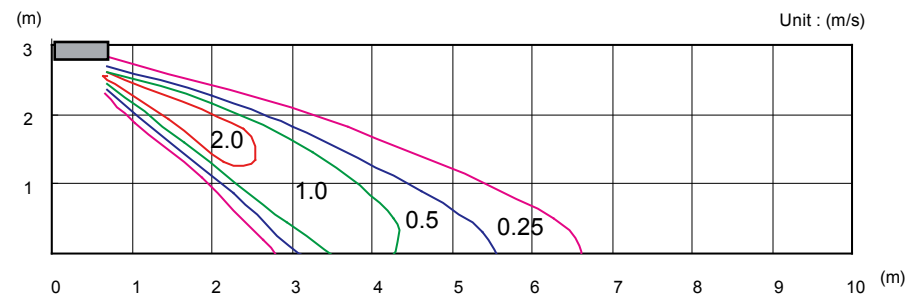

Side view  
Vertical flap : Down  
Horizontal flap : Center

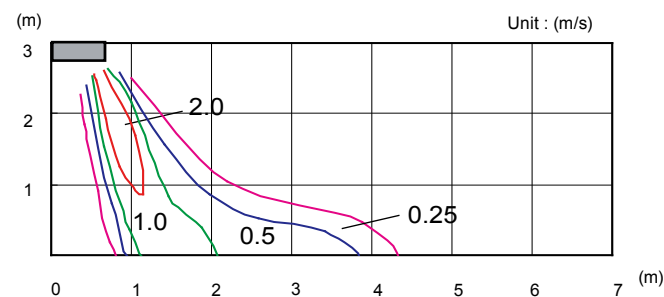

# MODEL : AB\*G18LVTB (FLOOR CONSOLE)

Conditions  
Fan speed : High  
Operation mode : Fan

Top view  
Vertical flap : Down  
Horizontal flap : Center

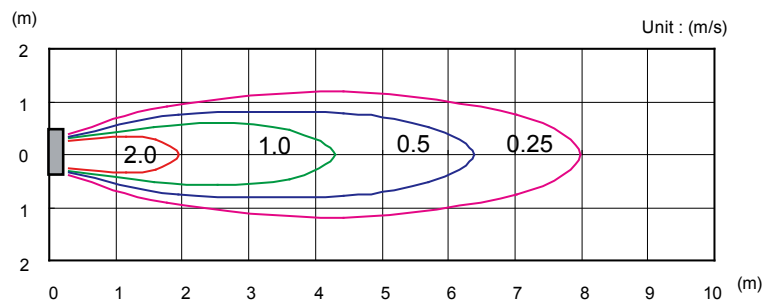

Top view  
Vertical flap : Down  
Horizontal flap : Right & Left

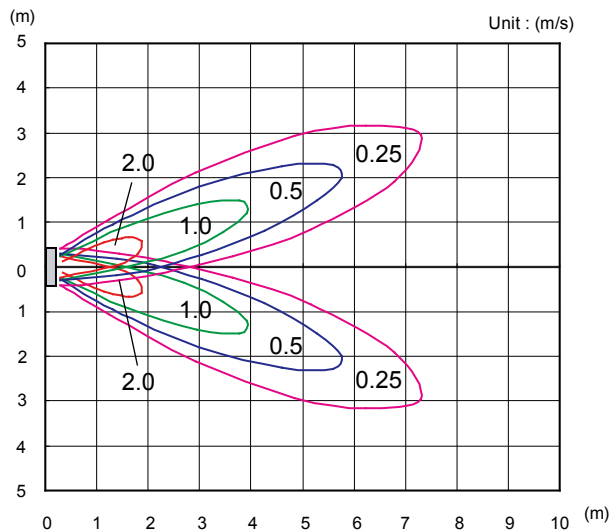

Side view  
Vertical flap : Down  
Horizontal flap : Center

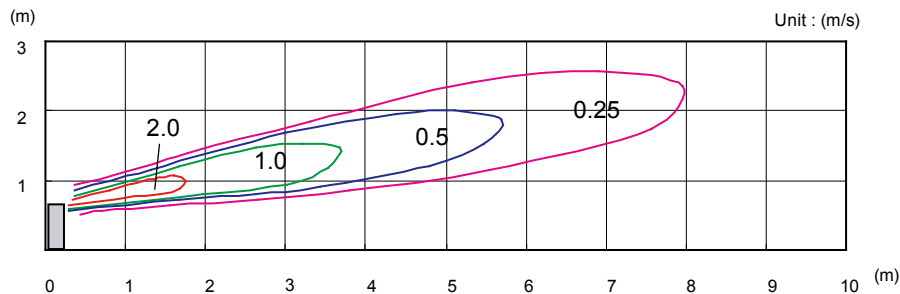

Side view  
Vertical flap : Center  
Horizontal flap : Center

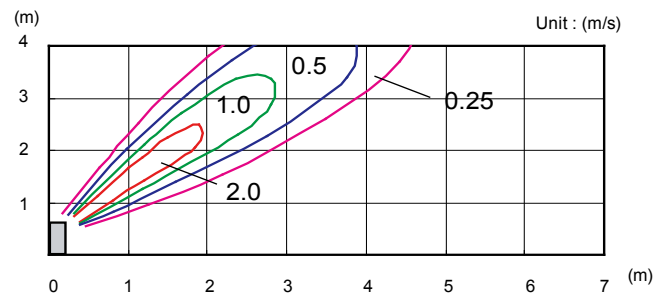

Side view  
Vertical flap : Up  
Horizontal flap : Center

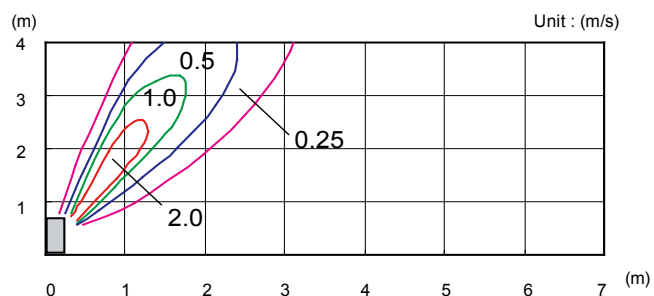



# MODEL : AB\*G24LVTA (UNDER CEILING)

Conditions  
Fan speed : High  
Operation mode : Fan

Top view  
Vertical flap : Up  
Horizontal flap : Center

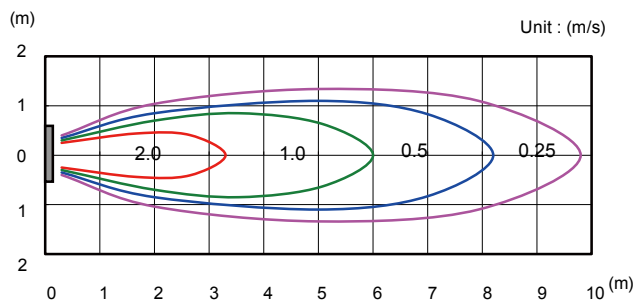

Top view  
Vertical flap : Up  
Horizontal flap : Right & Left

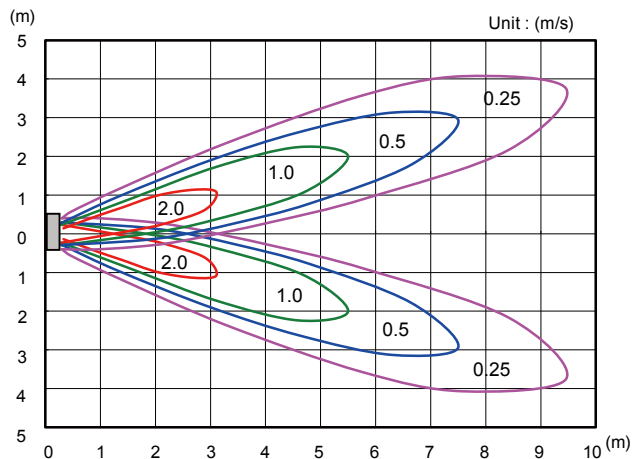

Side view  
Vertical flap : Up  
Horizontal flap : Center

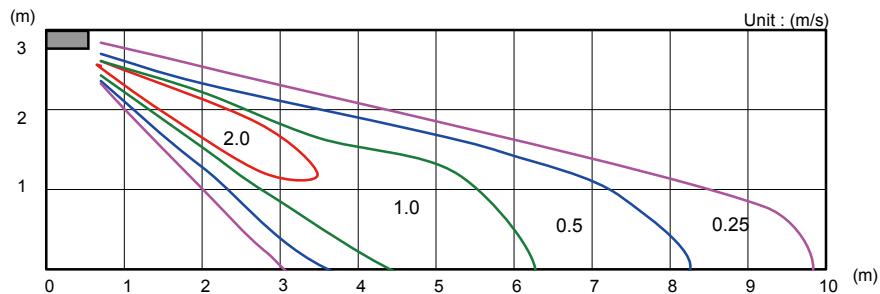

Side view  
Vertical flap : Center  
Horizontal flap : Center

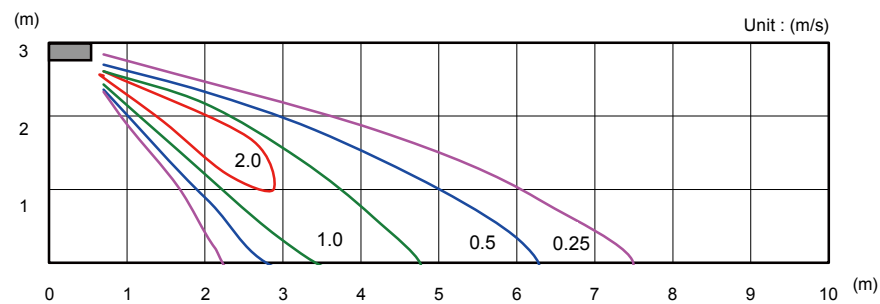

Side view  
Vertical flap : Down  
Horizontal flap : Center

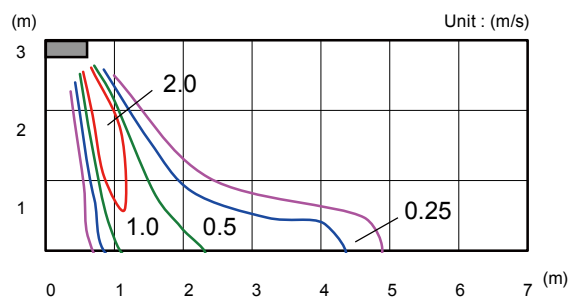

# MODEL : AB\*G24LVTA (FLOOR CONSOLE)

Conditions  
Fan speed : High  
Operation mode : Fan

Top view  
Vertical flap : Down  
Horizontal flap : Center

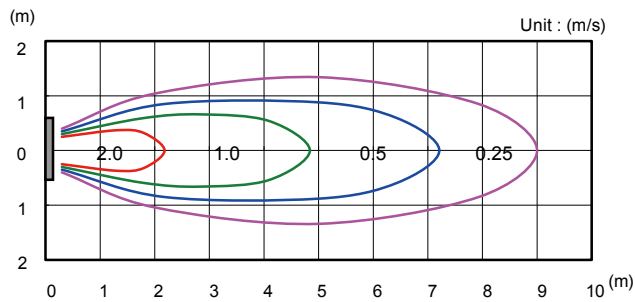

Top view  
Vertical flap : Down  
Horizontal flap : Right & Left

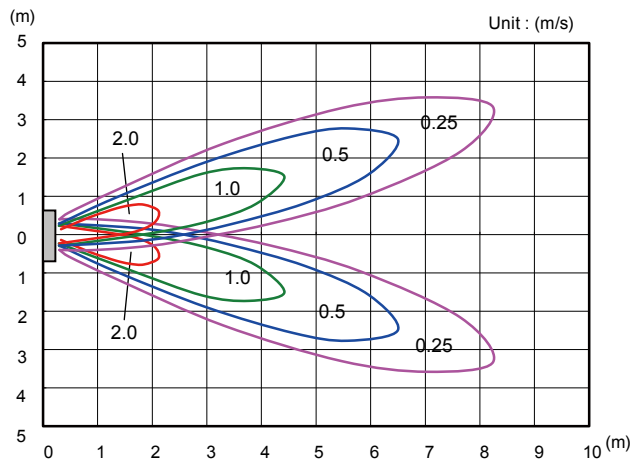

Side view  
Vertical flap : Down  
Horizontal flap : Center

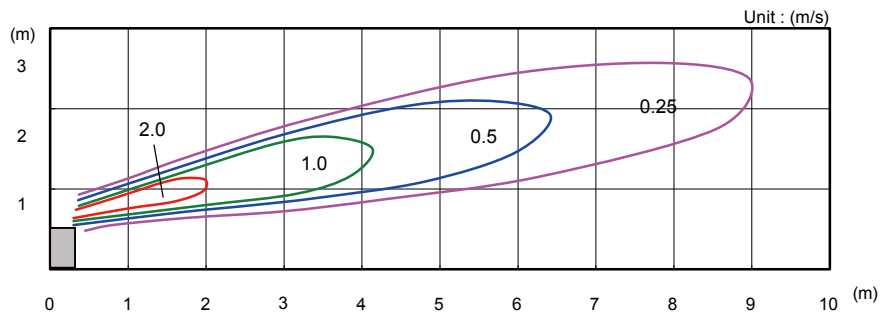

Side view  
Vertical flap : Center  
Horizontal flap : Center

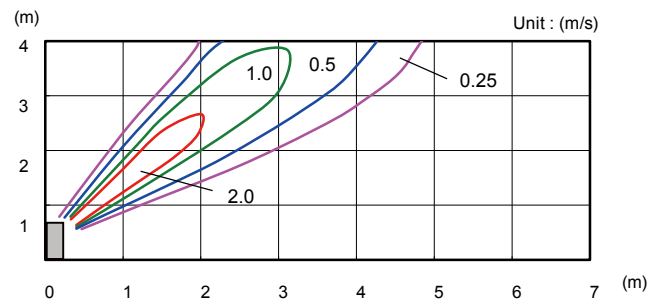

Side view  
Vertical flap : Up  
Horizontal flap : Center

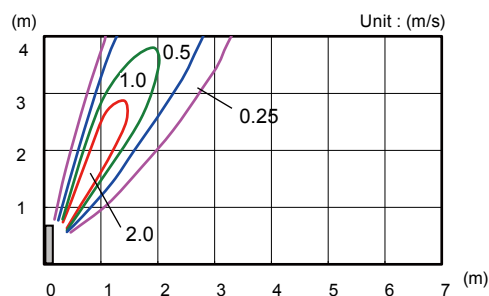

## 7-2. AIRFLOW

### ■ MODEL: AB\*G18LVTB

#### ● Cooling

Fan speed	Number of rotations (r.p.m.)	Airflow	
HIGH	1040	m <sup>3</sup> /h	780
		l/s	217
		CFM	459
MED	950	m <sup>3</sup> /h	700
		l/s	194
		CFM	412
LOW	800	m <sup>3</sup> /h	560
		l/s	156
		CFM	330
QUIET	740	m <sup>3</sup> /h	500
		l/s	139
		CFM	294

#### ● Heating

Fan speed	Number of rotations (r.p.m.)	Airflow	
HIGH	1040	m <sup>3</sup> /h	780
		l/s	217
		CFM	459
MED	950	m <sup>3</sup> /h	700
		l/s	194
		CFM	412
LOW	800	m <sup>3</sup> /h	560
		l/s	156
		CFM	330
QUIET	740	m <sup>3</sup> /h	500
		l/s	139
		CFM	294

## ■ MODEL: AB\*G24LVTA

### ● Cooling

Fan speed	Number of rotations (r.p.m.)	Airflow	
HIGH	1330	m <sup>3</sup> /h	980
		l/s	272
		CFM	577
MED	1150	m <sup>3</sup> /h	820
		l/s	228
		CFM	483
LOW	1000	m <sup>3</sup> /h	680
		l/s	189
		CFM	400
QUIET	780	m <sup>3</sup> /h	540
		l/s	150
		CFM	318

### ● Heating

Fan speed	Number of rotations (r.p.m.)	Airflow	
HIGH	1300	m <sup>3</sup> /h	980
		l/s	272
		CFM	577
MED	1150	m <sup>3</sup> /h	820
		l/s	228
		CFM	483
LOW	1000	m <sup>3</sup> /h	680
		l/s	189
		CFM	400
QUIET	780	m <sup>3</sup> /h	540
		l/s	150
		CFM	318

# 8. OPERATION NOISE

## 8-1. NOISE LEVEL CURVE (SOUND PRESSURE)

### MODEL: AB\*G18LVTB

#### ● Cooling

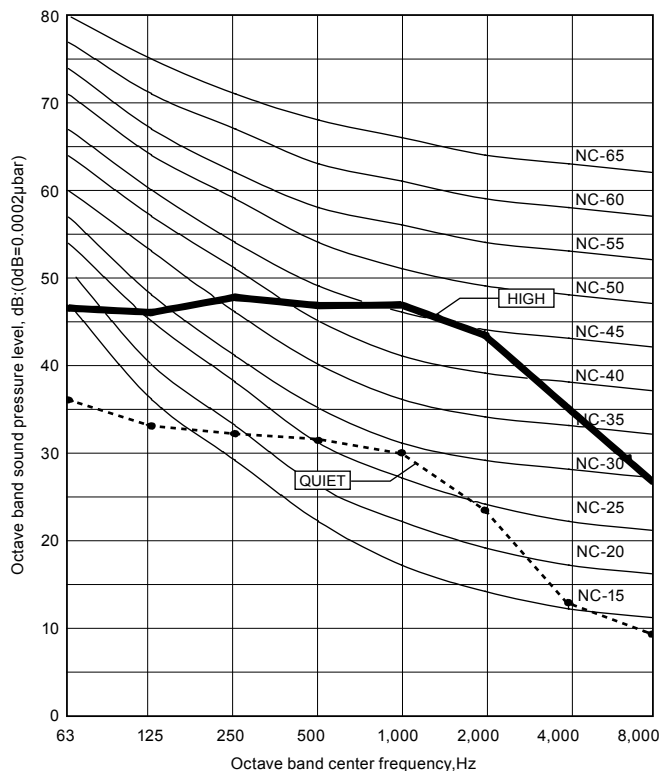

#### ● Heating

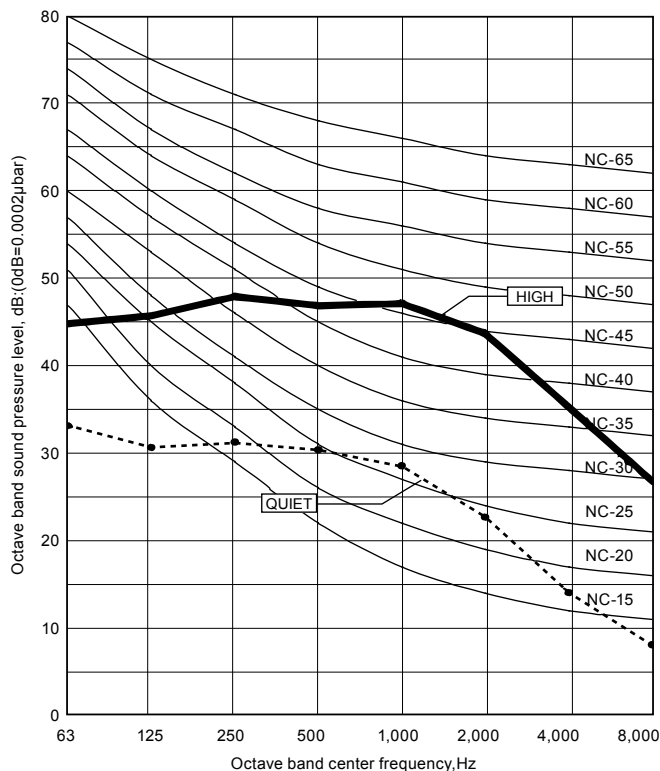

### MODEL: AB\*G24LVTA

#### ● Cooling

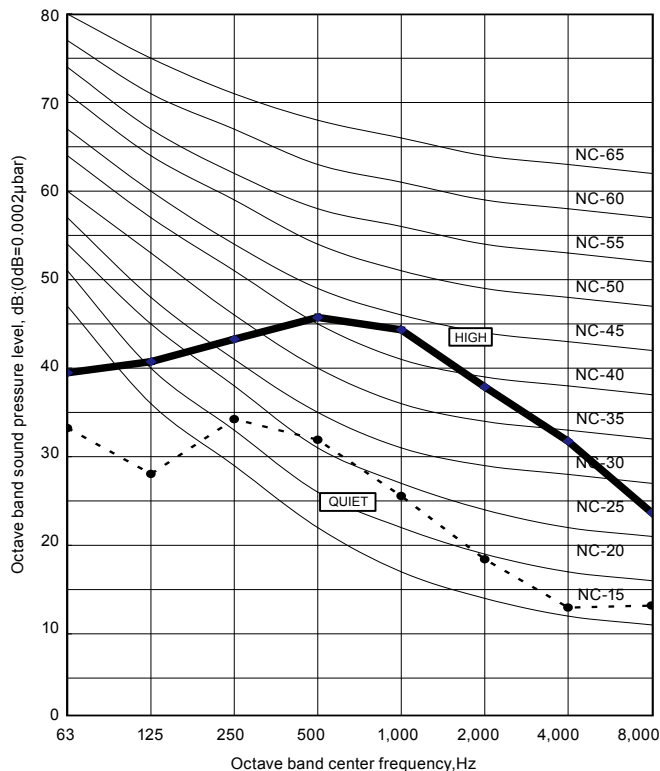

#### ● Heating

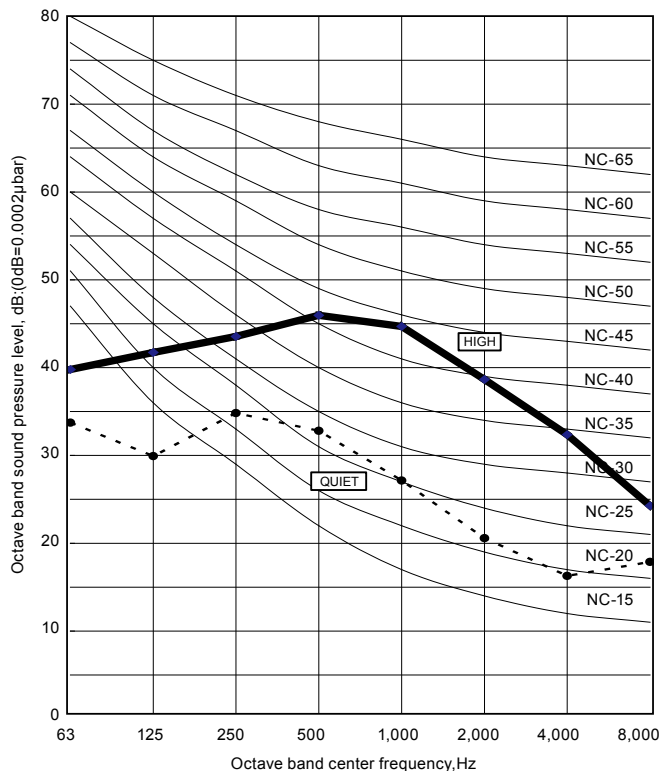

## 8-2. SOUND LEVEL CHECK POINT

### ● Floor console

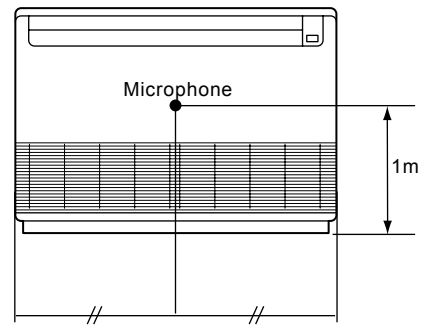
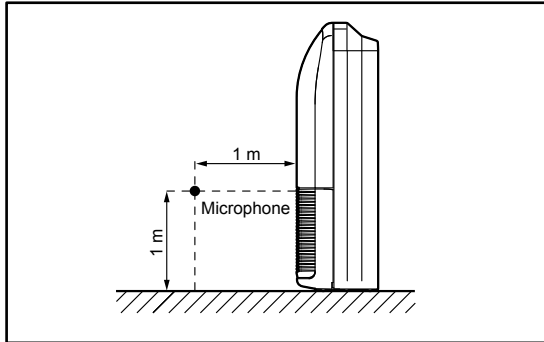

### ● Under ceiling

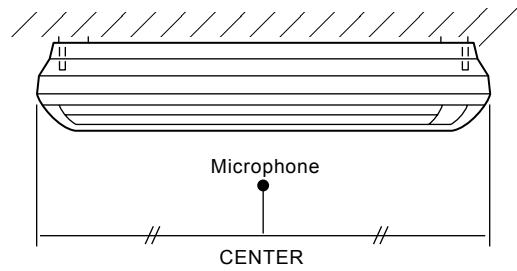
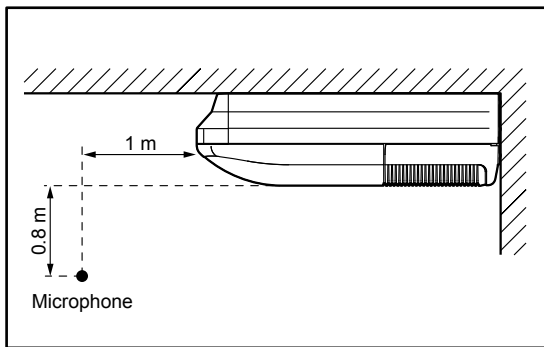

## 9. ELECTRIC CHARACTERISTICS

Model name			AB*G18LVTB	AB*G24LVTA
Power supply	Voltage	V	230 ~	
	Frequency	Hz	50	
Max. operating current		A	0.45	0.70
*1) Wiring Spec.	Connection cable	mm <sup>2</sup>	1.5	
	Limited wiring length	m	26	31

\*1) Wiring Spec.  
 Selected Sample  
 (Selected based on Japan Electrotechnical Standards and Codes Committee E0005)

## 10. SAFETY DEVICES

	Protection form	Model
		AB*G18LVTB AB*G24LVTA
Circuit protection	Current fuse (PCB)	250V 3.15A
Fan motor protection	Thermal protection program	135 ± 15 °C OFF 115 ± 15 °C ON



# 11. EXTERNAL INPUT & OUTPUT

Connector	INPUT	OUTPUT	REMARKS
CN102	Control input	—	See external input/output settings for details.
CN103	—	Operation status output	

## 11-1. EXTERNAL INPUT

### ■ CONTROL INPUT (Operation/Stop or Forced stop)

The air conditioner can be remotely operated by means of the following on-site work.

"Operation/Stop" mode or "Forced stop" mode can be selected with function setting of indoor unit.

Unit operation is started at the following contents by adding the contact input of a commercial ON/OFF switch to a connector on the external control PC board and turning it ON.

Unit operation	Initial setting after power is ON	Starting mode other than initial setting
Operation mode	Auto changeover	Mode at previous operation
Set temperature	24°C	Temperature at previous operation
Air flow mode	AUTO	Mode at previous operation
Up-down air direction (swing)	Standard air direction (swing OFF)	Air direction at previous operation
Left-right air direction (swing)	Standard air direction (swing OFF)	Air direction at previous operation

### ● Circuit diagram example

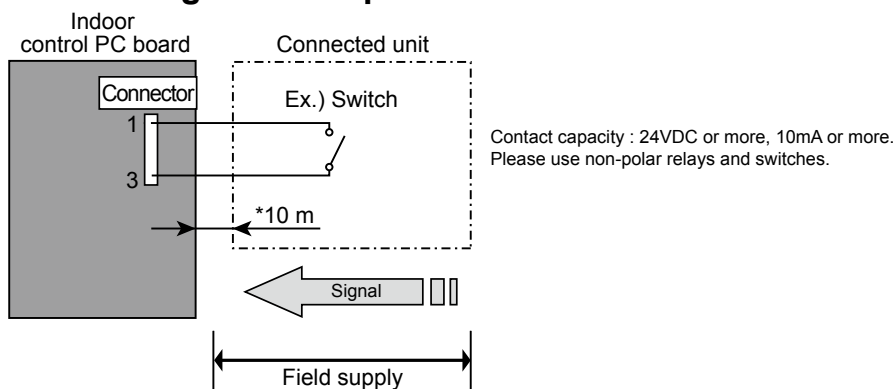

\* Make the distance from the PC board to the connected unit within 10m.

#### ● When function setting is in "Operation/Stop" mode

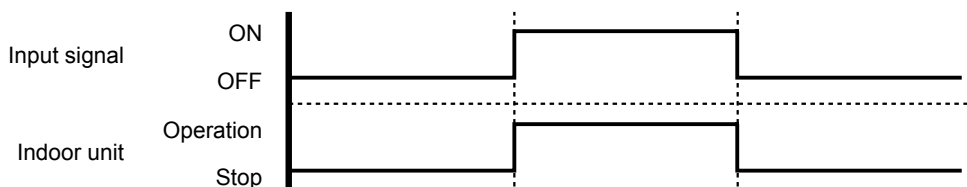

#### ● When function setting is in "Forced stop" mode

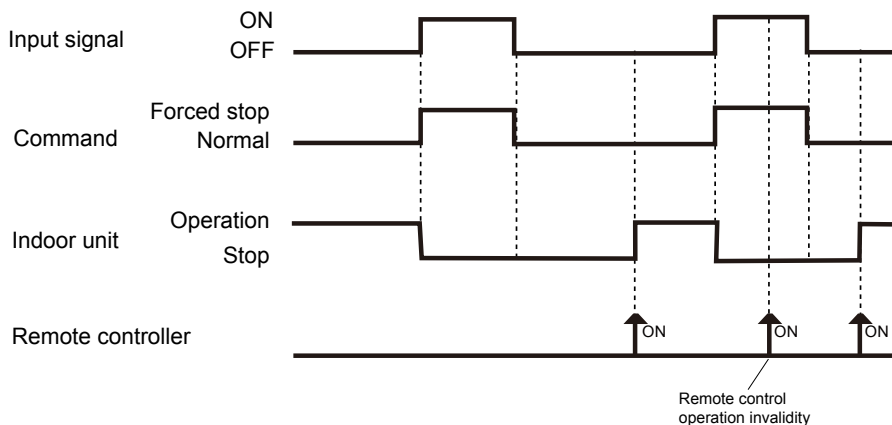

### ● Parts (Optional)

Model name
UTY-XWZX

Wire (External input)

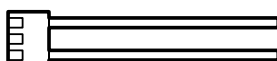

## 11-2. EXTERNAL OUTPUT

### ■ OPERATION STATUS OUTPUT

An air conditioner operation status signal can be output.

#### ● Circuit diagram example

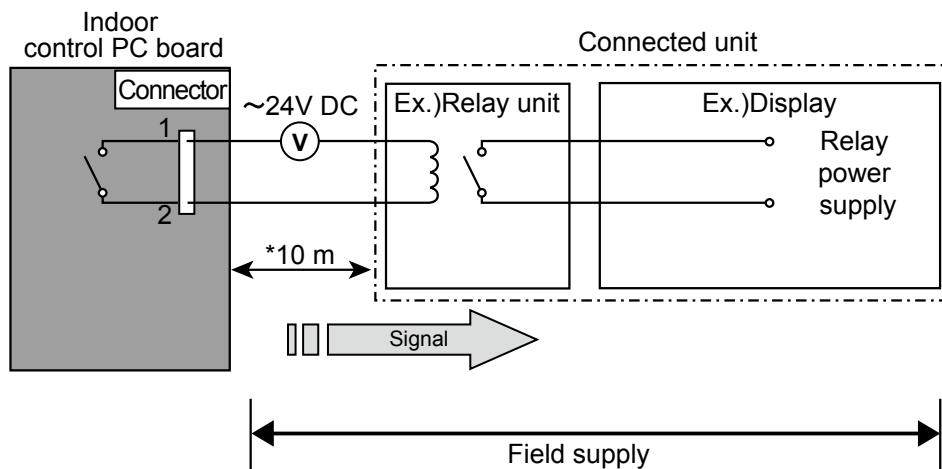

\* Make the distance from the PC board to the connected unit within 10m.  
Relay spec. : Max.24VDC, 10mA to less than 1A.

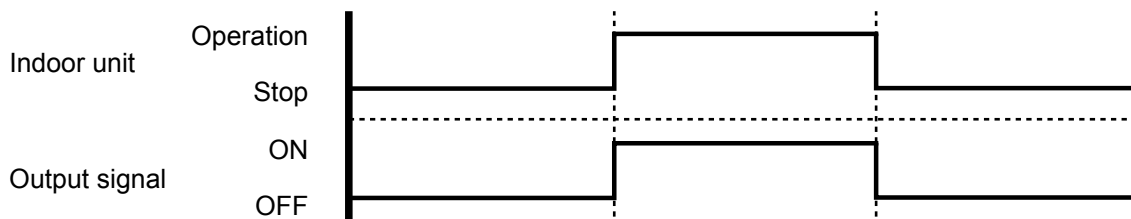

#### ● Parts (Optional)

Model name
UTY-XWZX

Wire (External output)

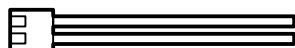

# 12. FUNCTION SETTINGS

## 12-1. INDOOR UNIT

INDOOR UNIT		
DIP SW	1	Remote controller address setting
	2	
	3	
	4	
Jumper Wire	JM1	Setting forbidden
	JM2	
	JM3	

### ■ SWITCH POSITION

#### MAIN PCB

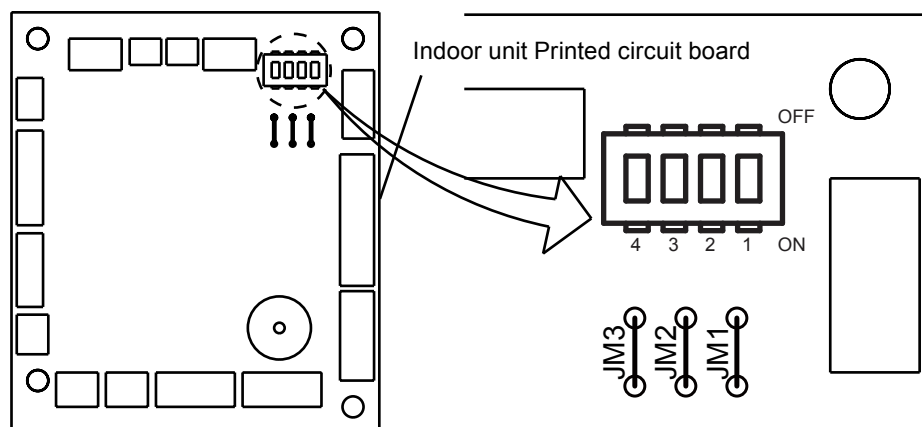

### ■ DIP-SW SETTING

#### ● Remote controller address setting

A number of indoor units can be operated at the same time using a wired remote controller. Set the unit number of each indoor unit using the DIP switches on the indoor unit circuit board. (See the following table.)

The DIP switches are normally set to make the unit number 00.

(◆ . . . Factory setting)

Remote controller address	DIP switch No.			
	1	2	3	4
◆ 00	OFF	OFF	OFF	OFF
01	ON	OFF	OFF	OFF
02	OFF	ON	OFF	OFF
03	ON	ON	OFF	OFF
04	OFF	OFF	ON	OFF
05	ON	OFF	ON	OFF
06	OFF	ON	ON	OFF
07	ON	ON	ON	OFF
08	OFF	OFF	OFF	ON
09	ON	OFF	OFF	ON
10	OFF	ON	OFF	ON
11	ON	ON	OFF	ON
12	OFF	OFF	ON	ON
13	ON	OFF	ON	ON
14	OFF	ON	ON	ON
15	ON	ON	ON	ON

## 12-2. INDOOR UNIT (Setting by remote controller)

- The function settings of the control of the indoor unit can be changed by this procedure according to the installation conditions. Incorrect settings can cause the indoor unit to malfunction.
- After the power is turned on, perform The Function Setting according to the installation conditions using the remote controller.
- The settings may be selected between the following two: Function Number or Setting Value.
- Settings will not be changed if invalid numbers or setting values are selected.

### ■ PREPARATION

- Turn on the power.
- \* Before turning on the power of the indoor units, make sure the piping air-tight test and vacuuming have been conducted .
- \* Also check again to make sure no wiring mistakes were made before turning on the power.

### ■ FUNCTION SETTING METHOD (for Wireless remote controller)

#### Entering the Function Setting Mode

- While pressing the FAN button and SET TEMP. (▲) simultaneously, press the RESET button to enter the function setting mode.

#### STEP 1

##### Setting the Remote controller Signal Code

Use the following steps to select the signal code of the remote controller. (Note that the air conditioner cannot receive a signal code if the air conditioner has not been set for the signal code.) The signal codes that are set through this process are applicable only to the signals in The Function Setting. For details on how to set the signal codes through the normal process, refer to REMOTE CONTROLLER SIGNAL CODE SETTING.

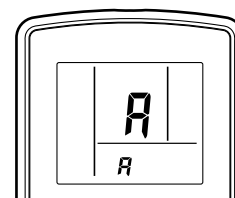

1. Press the SET TEMP. (▲) (▼) button to change the signal code between  $\bar{a} \rightarrow \bar{b}$   
 $\rightarrow \bar{c} \rightarrow \bar{d}$  Match the code on the display to the air conditioner signal code. (initially set to  $\bar{a}$ )  
 (If the signal code does not need to be selected, press the MODE button and proceed to STEP 2.)
2. Press the TIMER MODE button and check that the indoor unit can receive signals at the displayed signal code.
3. Press the MODE button to accept the signal code, and proceed to STEP 2.

The air conditioner signal code is set to A prior to shipment.

The remote controller resets to signal code A when the batteries in the remote controller are replaced. If you use a signal code other than signal code A, reset the signal code after replacing the batteries.  
 If you do not know the air conditioner signal code setting, try each of the signal codes ( $\bar{a} \rightarrow \bar{b} \rightarrow \bar{c} \rightarrow \bar{d}$ ) until you find the code which operates the air conditioner.

#### STEP 2

##### Selecting the Function Number and Setting Value

1. Press the SET TEMP. (▲) (▼) buttons to select the function number.  
 (Press the MODE button to switch between the left and right digits.)
2. Press the FAN button to proceed to setting the value.  
 Press the FAN button again to return to the function number selection.)
3. Press the SET TEMP. (▲) (▼) buttons to select the setting value.  
 (Press the MODE button to switch between the left and right digits.)
4. Press the TIMER MODE button, and START/STOP button, in the order listed to confirm the settings.
5. Press the RESET button to cancel the function setting mode.
6. After completing The Function Setting, be sure to turn off the power and turn it on again.

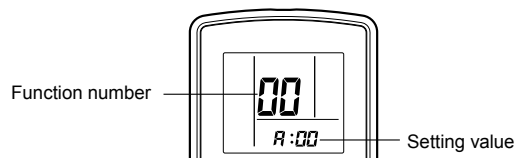

#### ⚠ CAUTION

After turning off the power, wait 10 seconds or more before turning it on again.  
 The Function Setting will not become active unless the power is turned off then on again.

## ■ CONTENTS OF FUNCTION SETTING

- Follow the instructions in the Local Setup Procedure, which is supplied with the remote control, in accordance with the installed condition.  
After the power is turned on, perform the Function Setting on the remote control.
- The settings may be selected between the following two: Function Number or Setting Value.
- Settings will not be changed if invalid numbers or setting values are selected.

1)	Filter sign
2)	Ceiling height
3)	Cooler room temperature correction
4)	Heater room temperature correction
5)	Auto restart
6)	Indoor room temperature sensor switching function
7)	Remote controller signal code
8)	External input control
9)	Indoor unit fan control for energy saving

### 1) Filter sign

The indoor unit has a sign to inform the user that it is time to clean the filter. Select the time setting for the filter sign display interval in the table below according to the amount of dust or debris in the room. If you do not wish the filter sign to be displayed, select the setting value for "No indication".

(◆ . . .Factory setting)

Setting Description	Function Number	Setting Value
"Standard (400 hours)"	11	00
"Long interval (1,000 hours)"		01
"Short interval (200 hours)"		02
No indication		03

### 2) Ceiling height

Select the setting values in the table below according to the height of the ceiling.

(◆ . . .Factory setting)

Setting Description	Function Number	Setting Value
Standard	20	00
High ceiling		01

### 3) Cooler room temperature correction

Depending on the installed environment, the room temperature sensor may require a correction. The settings may be selected as shown in the table below.

(◆ . . .Factory setting)

Setting Description	Function Number	Setting Value
Standard	30	00
Slightly lower control		01
Lower control		02
Warmer control		03

When using floor console installation, change the setting value to "01".

#### 4) Heater room temperature correction

Depending on the installed environment, the room temperature sensor may require correction. The settings may be changed as shown in the table below.

(◆ . . . Factory setting)

Setting Description	Function Number	Setting Value
◆ Standard	31	00
Lower control		01
Slightly warmer control		02
Warmer control		03

When using floor console installation, change the setting value to "01".

#### 5) Auto restart

Enable or disable automatic system restart after a power outage.

(◆ . . . Factory setting)

Setting Description	Function Number	Setting Value
◆ Yes	40	00
No		01

\* Auto restart is an emergency function such as for power failure etc. Do not start and stop the indoor unit by this function in normal operation. Be sure to operate by the control unit, or external input device.

#### 6) Indoor room temperature sensor switching function

(Only for Wired remote controller)

The following settings are needed when use the control by Wired remote controller temperature sensor.

(◆ . . . Factory setting)

Setting Description	Function Number	Setting Value
◆ No	42	00
Yes		01

- If setting value is "00", room temperature is controlled by the indoor unit temperature sensor.
- If setting value is "01", room temperature is controlled by either indoor unit temperature sensor or remote controller unit sensor.

#### 7) Remote controller signal code

Change the indoor unit Signal Code, depending on the remote controllers.

(◆ . . . Factory setting)

Setting Description	Function Number	Setting Value
◆ A	44	00
B		01
C		02
D		03

#### 8) External input control

"Operation/Stop" mode or "Forced stop" mode can be selected.

(◆ . . . Factory setting)

Setting Description	Function Number	Setting Value
◆ Operation/Stop mode	46	00
(Setting forbidden)		01
Forced stop mode		02

#### 9) Indoor unit fan control for energy saving (Only cooling mode)

Enable or disable indoor unit fan control when the outdoor unit is stopped.

(◆ . . . Factory setting)

Setting Description	Function Number	Setting Value
No	49	00
◆ Yes		01

- If setting value is "00", When the outdoor unit is stopped, the indoor unit fan operates following the setting on the remote controller continuously.
- If setting value is "01", When the outdoor unit is stopped, the indoor unit fan operates at very low speed intermittently.

## ■ REMOTE CONTROLLER SIGNAL CODE SETTING

Use the following steps to select the signal code of the remote controller.

(Note that the air conditioner cannot receive a signal code if the air conditioner has not been set for the signal code.)

1. Press the START/STOP button until only the clock is displayed on the remote controller display.
2. Press the MODE button for at least five seconds to display the current signal code (initially set to  $\overline{A}$ ).
3. Press the SET TEMP. ( $\blacktriangle$ ) ( $\blacktriangledown$ ) button to change the signal code between  $\overline{A} \rightarrow \overline{B} \rightarrow \overline{C} \rightarrow \overline{D}$ .  
Match the code on the display to the air conditioner signal code.
4. Press the MODE button again to return to the clock display. The signal code will be changed.

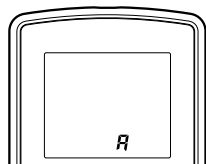



If no buttons are pressed within 30 seconds after the signal code is displayed, the system returns to the original clock display. In this case, start again from step 1.

The air conditioner signal code is set to A prior to shipment. Contact your retailer to change the signal code.

The remote controller resets to signal code A when the batteries in the remote controller are replaced. If you use a signal code other than signal code A, reset the signal code after replacing the batteries.  
If you do not know the air conditioner signal code setting, try each of the signal codes ( $\overline{A} \rightarrow \overline{B} \rightarrow \overline{C} \rightarrow \overline{D}$ .) until you find the code which operates the air conditioner.

# 13. OPTIONAL PARTS

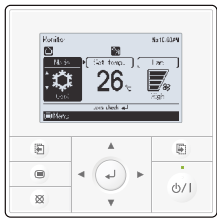
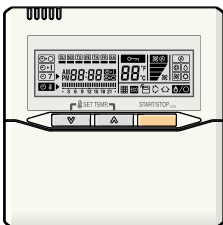
## 13-1. CONTROLLER

Exterior	Parts name	Model No.	Summary
	Wired remote controller	UTY-RVN*M	Large and full-dot liquid crystal screen, wide and large keys easy to press, user-intuitive arrow key.
	Wired remote controller	UTY-RNN*M	The room temperature can be controlled by detecting the temperature accurately with built-in thermo sensor.
	Simple remote controller	UTY-RSN*M	Compact remote controller concentrates on the basic functions such as Start/Stop, Fan Control, Temperature Setting and Operation mode.

## 13-2. OTHERS

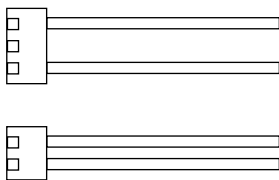
Exterior	Parts name	Model No.	Summary
	External connect kit	UTY-XWZX	Use to connect with various peripheral devices and air conditioner PC board.



## **2. OUTDOOR UNIT**

---

**SINGLE TYPE :**

**AO\*G12LALL**

**AO\*G14LALL**

**AO\*G18LALL**

**AO\*G24LALA**

# CONTENTS

---

## 2. OUTDOOR UNIT

---

1. SPECIFICATIONS.....	02 - 01
2. DIMENSIONS .....	02 - 02
3. REFRIGERANT CIRCUIT .....	02 - 03
4. WIRING DIAGRAMS.....	02 - 04
5. CAPACITY COMPENSATION RATE FOR PIPE LENGTH AND HEIGHT DIFFERENCE .....	02 - 06
6. ADDITIONAL CHARGE CALCULATION.....	02 - 10
7. AIRFLOW .....	02 - 11
8. OPERATION NOISE (SOUND PRESSURE).....	02 - 13
8-1. NOISE LEVEL CURVE.....	02 - 13
8-2. SOUND LEVEL CHECK POINT .....	02 - 15
9. ELECTRIC CHARACTERISTICS.....	02 - 16
10. SAFETY DEVICES .....	02 - 17

# 1. SPECIFICATIONS

OUTDOOR UNIT  
AO\*G12-24LAL

OUTDOOR UNIT  
AO\*G12-24LAL

Type			INVERTER HEAT PUMP				
Model name			AO*G12LALL	AO*G14LALL	AO*G18LALL	AO*G24LALA	
Power source			230V ~ 50Hz				
Available voltage range			198 - 264V ~ 50Hz				
Starting current			A	5.1	6.1	7.4	9.9
Fan	Airflow rate	Cooling	m <sup>3</sup> /h	1780	1910	2000	2470
		Heating		1630	1740	1910	2470
	Type × Q'ty	Propeller × 1					
Motor output			W	54		65	
Sound pressure level	Cooling	dB (A)	47	49	50	52	
			Heating	48	49	50	53
Sound power level	Cooling	dB (A)	61	62	62	67	
			Heating	63	64	65	70
Heat exchanger type	Dimensions (H × W × D)	mm	546 × 876 × 18.2			546 × 866 × 18.2	
			546 × 842 × 18.2			546 × 832 × 18.2	
	Fin pitch	1.30			1.40		
	Rows × Stages	2 × 26			2 × 26		
	Pipe type	Copper					
Fin Type			Aluminium				
Compressor	Type × Q'ty	Twin Rotary × 1					
	Motor output	W	1100				
Refrigerant	Type (Global Warming Potential)	R410A(1975)					
	Charge	g	1150	1250		1700	
Refrigerant oil	Type	POE					
Enclosure	Material	Steel sheet					
	Colour	Beige Approximate colour of MUNSELL 10YR7.5/1.0					
Dimensions (H × W × D)	Net	mm	578 × 790 × 300			578 × 790 × 315	
	Gross		648 × 910 × 380				
Weight	Net	kg	40			44	
	Gross		44			48	
Connention pipe	Size	Liquid	mm	Ø6.35 (Ø1/4 in.)			
		Gas		Ø9.52 (Ø3/8 in.)	Ø12.70 (Ø1/2 in.)	Ø15.88 (Ø5/8 in.)	
	Method	Flare					
	Pre-charge length	m	15				
	Max. length		25		30		
Max. height difference	15		20				
Operation range	Cooling	°C	-10 to 46				
	Heating		-15 to 24				

**Note :**

Specifications are based on the following conditions.  
 Cooling : Indoor temperature of 27 °CDB / 19 °CWB. and outdoor temperature of 35 °CDB / 24 °CWB.  
 Heating : Indoor temperature of 20 °CDB / 15 °CWB. and outdoor temperature of 7 °CDB / 6 °CWB.  
 Pipe length : 5.0 m, Height difference : 0 m. (Outdoor unit - Indoor unit)  
 The protective function may work when using it outside the operation range.

## 2. DIMENSIONS

■ MODEL: AO\*G12LALL, AO\*G14LALL, AO\*G18LALL, AO\*G24LALA

(Unit : mm)

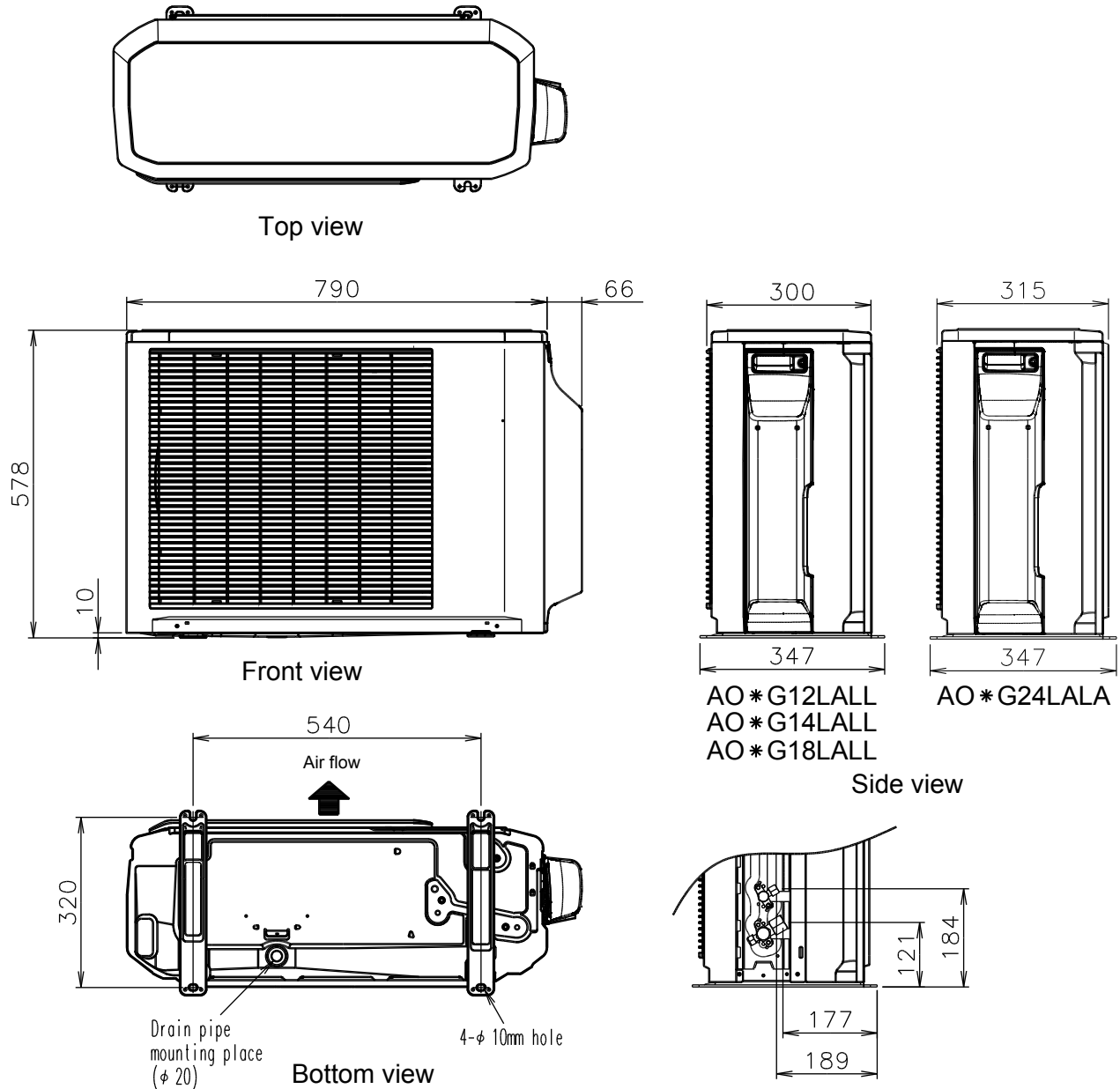

## ■ INSTALLATION PLACE

When there are obstacles at the back or front sides.

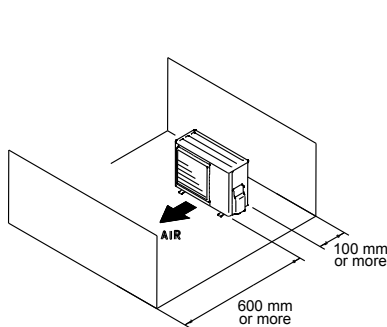

When there are obstacles at the back, side(s), and top.

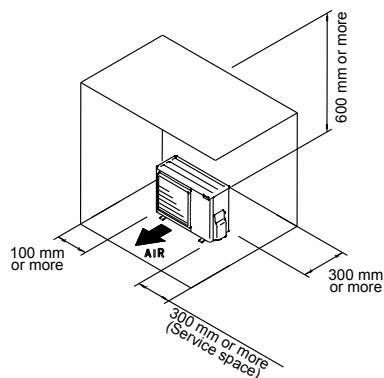

When there are obstacles at the back, side with the installation of more than one unit.

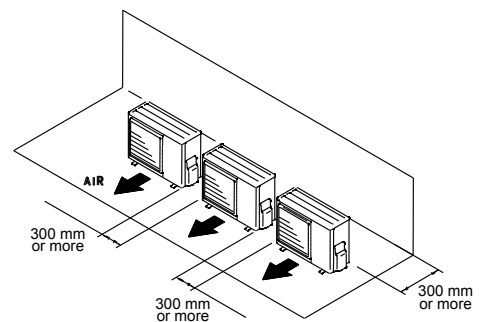

### 3. REFRIGERANT CIRCUIT

■ MODEL: AO\*G12LALL, AO\*G14LALL, AO\*G18LALL, AO\*G24LALA

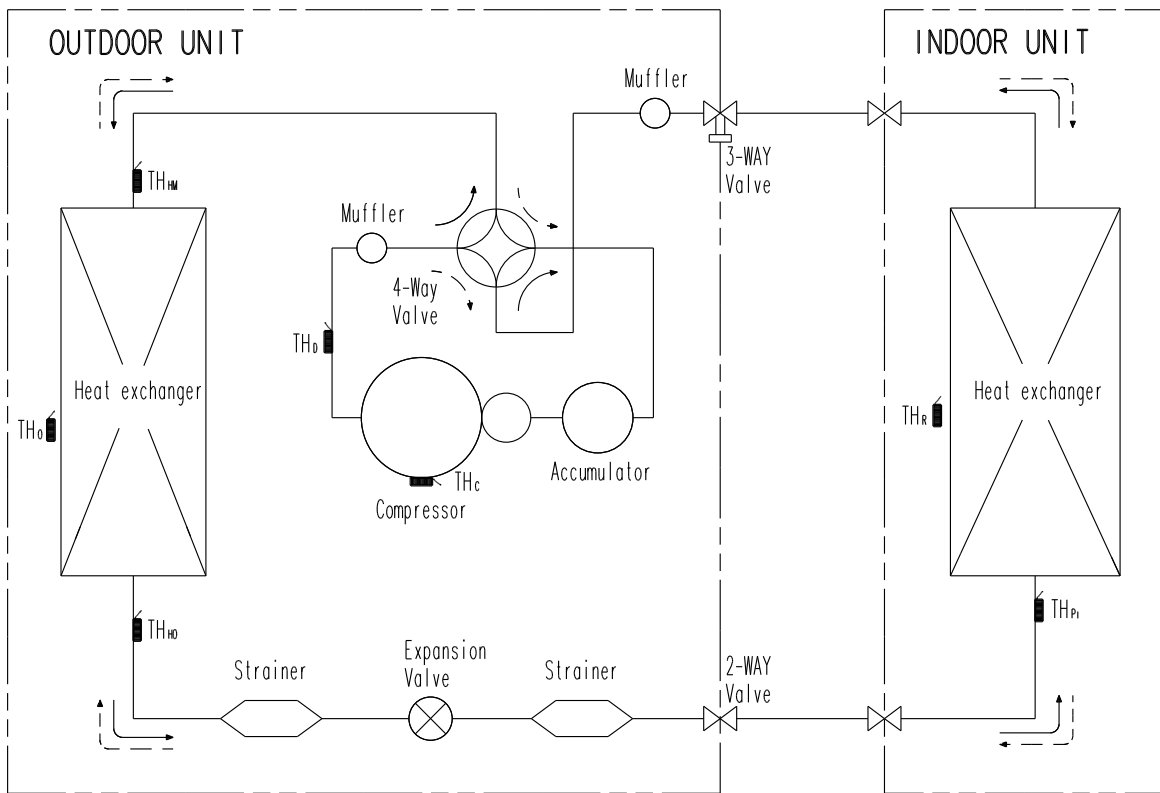

→ Cooling  
 - - - Heating

TH<sub>c</sub> : THERMISTOR (COMPRESSOR TEMP.)  
 TH<sub>d</sub> : THERMISTOR (DISCHARGE TEMP.)  
 TH<sub>m</sub> : THERMISTOR (HEAT EXCHANGER MED TEMP.)  
 TH<sub>o</sub> : THERMISTOR (HEAT EXCHANGER OUT TEMP.)  
 TH<sub>o</sub> : THERMISTOR (OUTDOOR TEMP.)

TH<sub>p</sub> : THERMISTOR (PIPE TEMP.)  
 TH<sub>r</sub> : THERMISTOR (ROOM TEMP.)

Refrigerant pipe diameter

- Liquid : 1/4" (6.35 mm)
- Gas : 3/8" (9.52 mm) : AO\*G12LALL
- 1/2" (12.70 mm) : AO\*G14LALL, AO\*G18LALL
- 5/8" (15.88 mm) : AO\*G24LALA

OUTDOOR UNIT  
AO\*G12-24LAL

OUTDOOR UNIT  
AO\*G12-24LAL

# 4. WIRING DIAGRAMS

■ MODEL: AO\*G12LALL, AO\*G14LALL, AO\*G18LALL

OUTDOOR UNIT  
AO\*G12-24LAL

OUTDOOR UNIT  
AO\*G12-24LAL

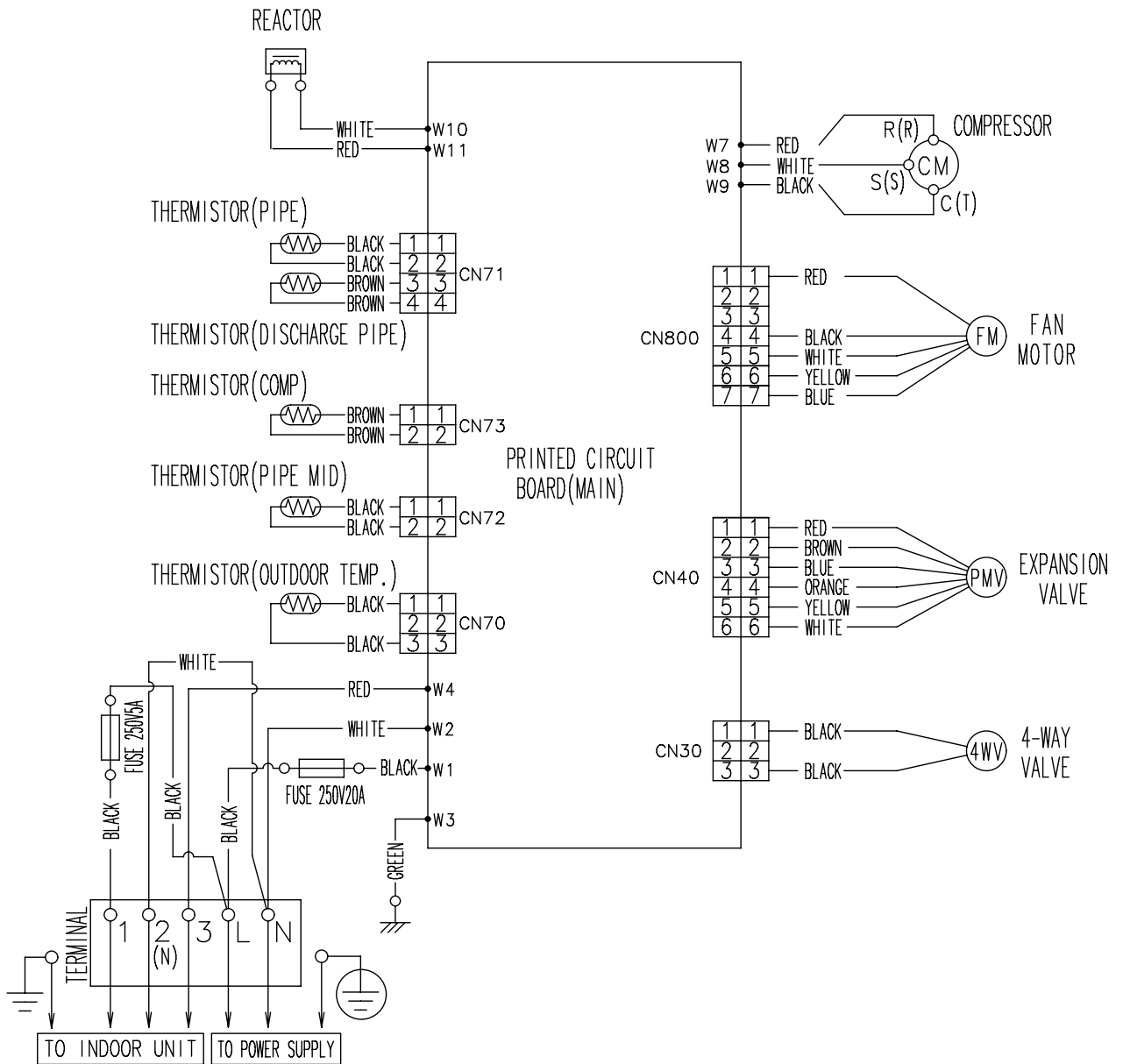

# MODEL: AO\*G24LALA

OUTDOOR UNIT  
AO\*G12-24LAL

OUTDOOR UNIT  
AO\*G12-24LAL

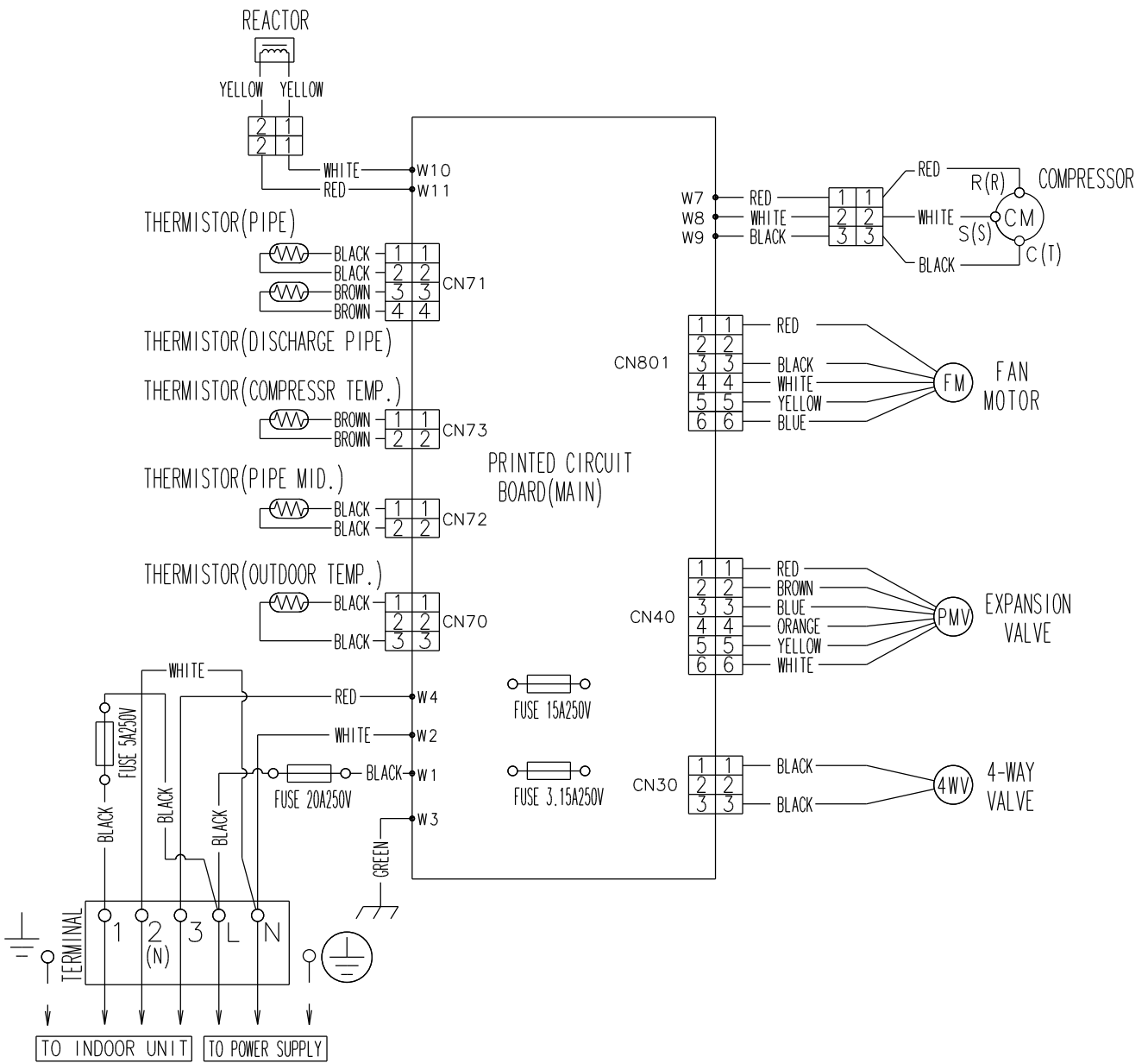

# 5. CAPACITY COMPENSATION RATE FOR PIPE LENGTH AND HEIGHT DIFFERENCE

This table is created using the maximum capacity.

## MODEL: AO\*G12LALL

OUTDOOR UNIT  
AO\*G12-24LAL

OUTDOOR UNIT  
AO\*G12-24LAL

COOLING			Pipe length (m)					
			5	7.5	10	15	20	25
Height difference H (m)	*1 Indoor unit is higher than outdoor unit.	15	-	-	-	0.903	0.894	0.867
		10	-	-	0.964	0.918	0.909	0.881
		7.5	-	0.988	0.968	0.922	0.912	0.885
		5	0.992	0.992	0.972	0.925	0.916	0.888
	0	1.000	1.000	0.980	0.933	0.923	0.895	
	*2 Indoor unit is lower than outdoor unit.	-5	1.000	1.000	0.980	0.933	0.923	0.895
		-7.5	-	1.000	0.980	0.933	0.923	0.895
		-10	-	-	0.980	0.933	0.923	0.895
		-15	-	-	-	0.933	0.923	0.895

HEATING			Pipe length (m)					
			5	7.5	10	15	20	25
Height difference H (m)	*1 Indoor unit is higher than outdoor unit.	15	-	-	-	0.943	0.916	0.896
		10	-	-	1.010	0.943	0.916	0.896
		7.5	-	1.000	1.010	0.943	0.916	0.896
		5	1.000	1.000	1.010	0.943	0.916	0.896
	0	1.000	1.000	1.010	0.943	0.916	0.896	
	*2 Indoor unit is lower than outdoor unit.	-5	0.995	0.995	1.005	0.939	0.912	0.892
		-7.5	-	0.993	1.002	0.936	0.909	0.890
		-10	-	-	0.999	0.934	0.907	0.887
		-15	-	-	-	0.925	0.898	0.878

Height difference H

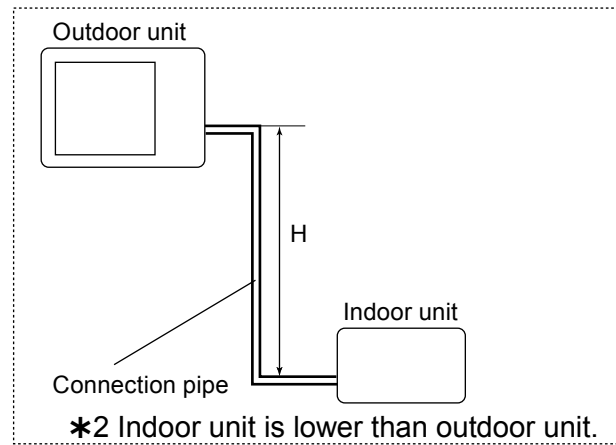
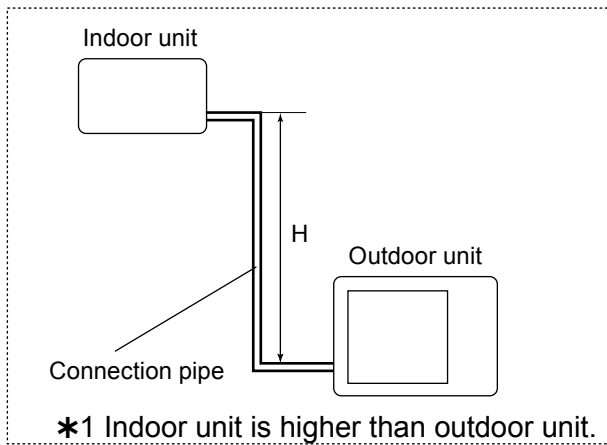



This table is created using the maximum capacity.

**MODEL: AO\*G14LALL**

OUTDOOR UNIT  
AO\*G12-24LAL

OUTDOOR UNIT  
AO\*G12-24LAL

COOLING			Pipe length (m)					
			5	7.5	10	15	20	25
Height difference H (m)	*1 Indoor unit is higher than outdoor unit.	15	-	-	-	0.953	0.950	0.947
		10	-	-	0.983	0.968	0.966	0.962
		7.5	-	0.988	0.987	0.972	0.970	0.966
		5	0.992	0.992	0.991	0.976	0.974	0.970
	0	1.000	1.000	0.999	0.984	0.982	0.978	
	*2 Indoor unit is lower than outdoor unit.	-5	1.000	1.000	0.999	0.984	0.982	0.978
		-7.5	-	1.000	0.999	0.984	0.982	0.978
		-10	-	-	0.999	0.984	0.982	0.978
		-15	-	-	-	0.984	0.982	0.978

HEATING			Pipe length (m)					
			5	7.5	10	15	20	25
Height difference H (m)	*1 Indoor unit is higher than outdoor unit.	15	-	-	-	0.918	0.891	0.862
		10	-	-	0.981	0.918	0.891	0.862
		7.5	-	1.000	0.981	0.918	0.891	0.862
		5	1.000	1.000	0.981	0.918	0.891	0.862
	0	1.000	1.000	0.981	0.918	0.891	0.862	
	*2 Indoor unit is lower than outdoor unit.	-5	0.995	0.995	0.976	0.914	0.886	0.858
		-7.5	-	0.993	0.974	0.912	0.884	0.856
		-10	-	-	0.972	0.909	0.882	0.854
		-15	-	-	-	0.900	0.873	0.845

Height difference H

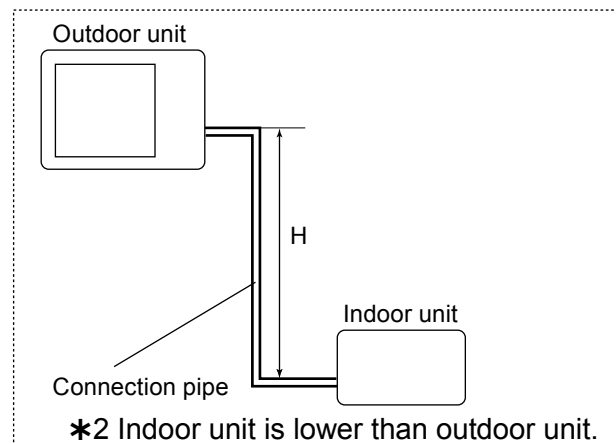
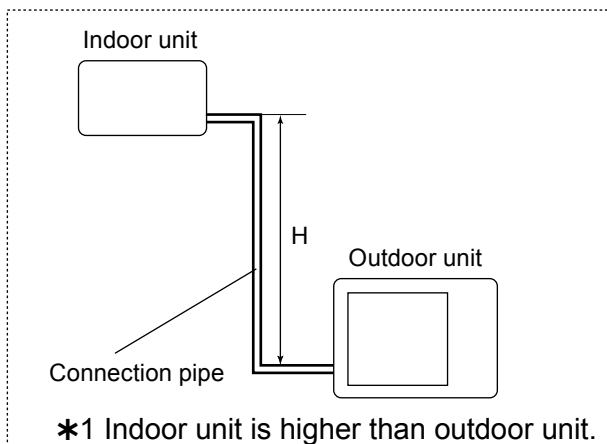

This table is created using the maximum capacity.

**MODEL: AO\*G18LALL**

OUTDOOR UNIT  
AO\*G12-24LAL

OUTDOOR UNIT  
AO\*G12-24LAL

COOLING			Pipe length (m)					
			5	7.5	10	15	20	25
Height difference H (m)	*1 Indoor unit is higher than outdoor unit.	15	-	-	-	0.953	0.950	0.947
		10	-	-	0.983	0.968	0.966	0.962
		7.5	-	0.988	0.987	0.972	0.970	0.966
		5	0.992	0.992	0.991	0.976	0.974	0.970
		0	1.000	1.000	0.999	0.984	0.982	0.978
	*2 Indoor unit is lower than outdoor unit.	-5	1.000	1.000	0.999	0.984	0.982	0.978
		-7.5	-	1.000	0.999	0.984	0.982	0.978
		-10	-	-	0.999	0.984	0.982	0.978
		-15	-	-	-	0.984	0.982	0.978

HEATING			Pipe length (m)					
			5	7.5	10	15	20	25
Height difference H (m)	*1 Indoor unit is higher than outdoor unit.	15	-	-	-	0.920	0.894	0.867
		10	-	-	0.982	0.920	0.894	0.867
		7.5	-	1.000	0.982	0.920	0.894	0.867
		5	1.000	1.000	0.982	0.920	0.894	0.867
		0	1.000	1.000	0.982	0.920	0.894	0.867
	*2 Indoor unit is lower than outdoor unit.	-5	0.995	0.995	0.977	0.916	0.889	0.862
		-7.5	-	0.993	0.975	0.913	0.887	0.860
		-10	-	-	0.972	0.911	0.885	0.858
		-15	-	-	-	0.902	0.876	0.849

Height difference H

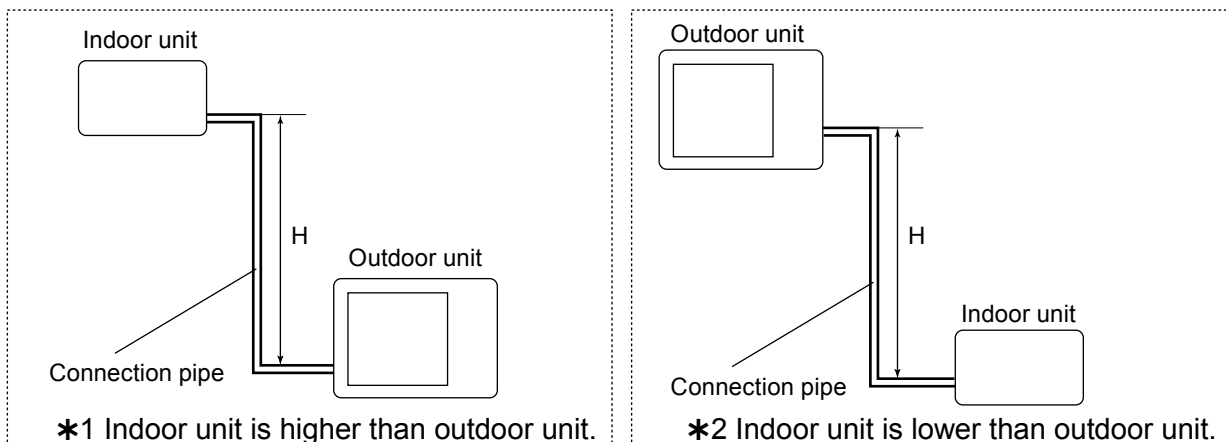

This table is created using the maximum capacity.

**MODEL: AO\*G24LALA**

OUTDOOR UNIT  
AO\*G12-24LAL

OUTDOOR UNIT  
AO\*G12-24LAL

COOLING			Pipe length (m)							
			5	7.5	10	15	20	25	30	
Height difference H (m)	*1 Indoor unit is higher than outdoor unit.	20	-	-	-	-	0.963	0.961	0.959	
		10	-	-	0.984	0.981	0.979	0.977	0.975	
		7.5	-	0.988	0.988	0.985	0.983	0.981	0.979	
		5	0.992	0.992	0.992	0.989	0.987	0.985	0.983	
			0	1.000	1.000	1.000	0.997	0.995	0.993	0.991
	*2 Indoor unit is lower than outdoor unit.	-5	1.000	1.000	1.000	0.997	0.995	0.993	0.991	
		-7.5	-	1.000	1.000	0.997	0.995	0.993	0.991	
		-10	-	-	1.000	0.997	0.995	0.993	0.991	
		-20	-	-	-	-	0.995	0.993	0.991	

HEATING			Pipe length (m)							
			5	7.5	10	15	20	25	30	
Height difference H (m)	*1 Indoor unit is higher than outdoor unit.	20	-	-	-	-	0.927	0.893	0.863	
		10	-	-	0.992	0.952	0.927	0.893	0.863	
		7.5	-	1.000	0.992	0.952	0.927	0.893	0.863	
		5	1.000	1.000	0.992	0.952	0.927	0.893	0.863	
			0	1.000	1.000	0.992	0.952	0.927	0.893	0.863
	*2 Indoor unit is lower than outdoor unit.	-5	0.995	0.995	0.987	0.947	0.922	0.888	0.859	
		-7.5	-	0.993	0.984	0.945	0.920	0.886	0.857	
		-10	-	-	0.982	0.943	0.917	0.884	0.855	
		-20	-	-	-	-	0.908	0.875	0.846	

Height difference H

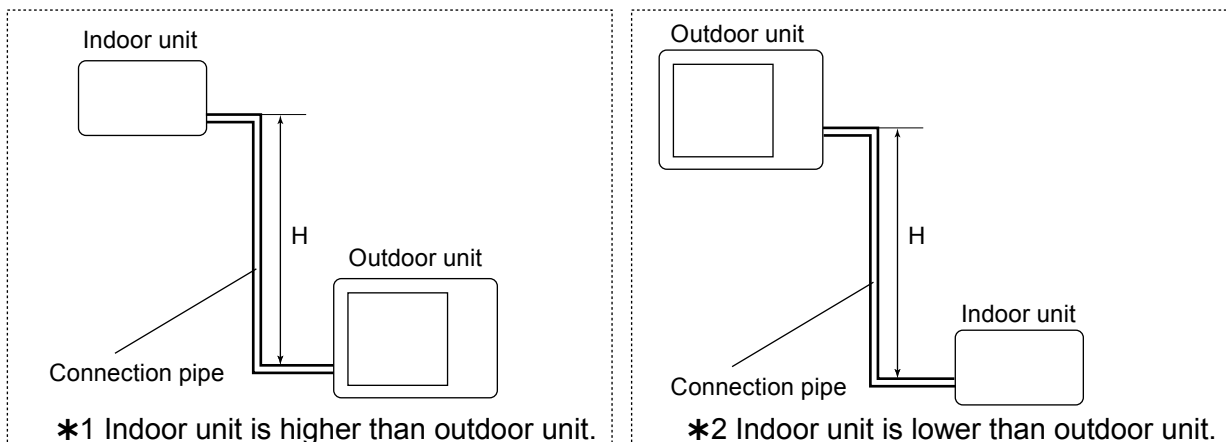

## 6. ADDITIONAL CHARGE CALCULATION

### ■ MODEL: AO\*G12LALL

Refrigerant type		R410A
Refrigerant amount	g	1150

#### ● Refrigerant charge

Total pipe length	m	15 or less	20	25 (MAX)	20g/m
Additional charge	g	0	100	200	

### ■ MODEL: AO\*G14LALL, AO\*G18LALL

Refrigerant type		R410A
Refrigerant amount	g	1250

#### ● Refrigerant charge

Total pipe length	m	15 or less	20	25 (MAX)	20g/m
Additional charge	g	0	100	200	

### ■ MODEL: AO\*G24LALA

Refrigerant type		R410A
Refrigerant amount	g	1700

#### ● Refrigerant charge

Total pipe length	m	15 or less	20	25	30 (MAX)	20g/m
Additional charge	g	0	100	200	300	

## 7. AIRFLOW

### ■ MODEL: AO\*G12LALL

#### ● Cooling

Number of rotations (r.p.m.)	Airflow	
	770	m <sup>3</sup> /h
l/s		494
CFM		1048

#### ● Heating

Number of rotations (r.p.m.)	Airflow	
	700	m <sup>3</sup> /h
l/s		453
CFM		959

### ■ MODEL: AO\*G14LALL

#### ● Cooling

Number of rotations (r.p.m.)	Airflow	
	820	m <sup>3</sup> /h
l/s		531
CFM		1124

#### ● Heating

Number of rotations (r.p.m.)	Airflow	
	750	m <sup>3</sup> /h
l/s		483
CFM		1024

## ■ MODEL: AO\*G18LALL

### ● Cooling

Number of rotations (r.p.m.)	Airflow	
	860	m <sup>3</sup> /h
l/s		556
CFM		1177

### ● Heating

Number of rotations (r.p.m.)	Airflow	
	820	m <sup>3</sup> /h
l/s		531
CFM		1124

## ■ MODEL: AO\*G24LALA

### ● Cooling

Number of rotations (r.p.m.)	Airflow	
	1050	m <sup>3</sup> /h
l/s		686
CFM		1454

### ● Heating

Number of rotations (r.p.m.)	Airflow	
	1050	m <sup>3</sup> /h
l/s		686
CFM		1454

# 8. OPERATION NOISE (SOUND PRESSURE)

## 8-1. NOISE LEVEL CURVE

### MODEL: AO\*G12LALL

#### ● Cooling

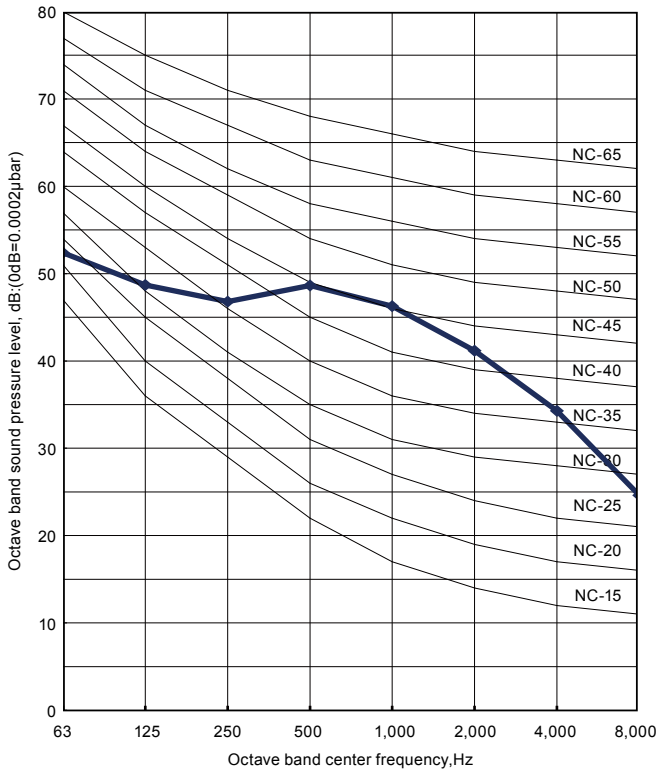

#### ● Heating

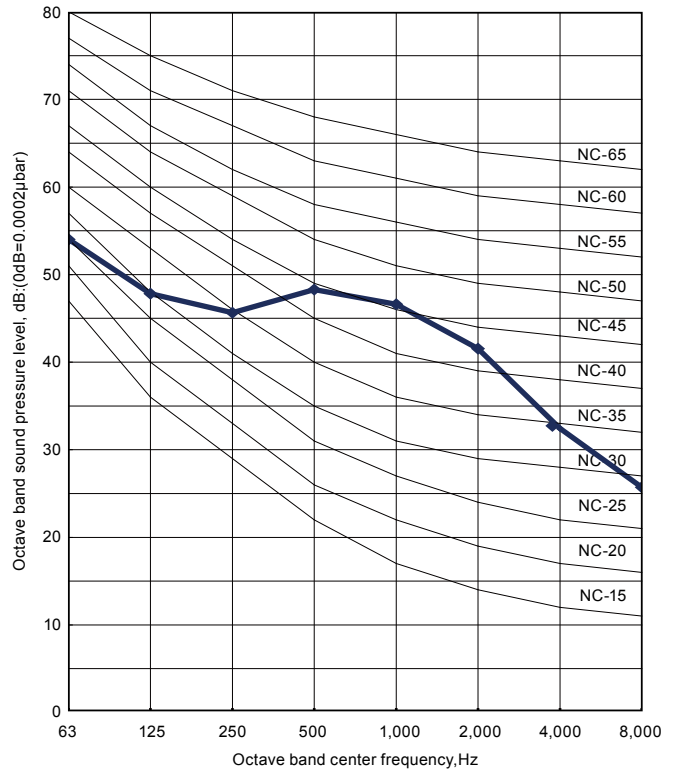

### MODEL: AO\*G14LALL

#### ● Cooling

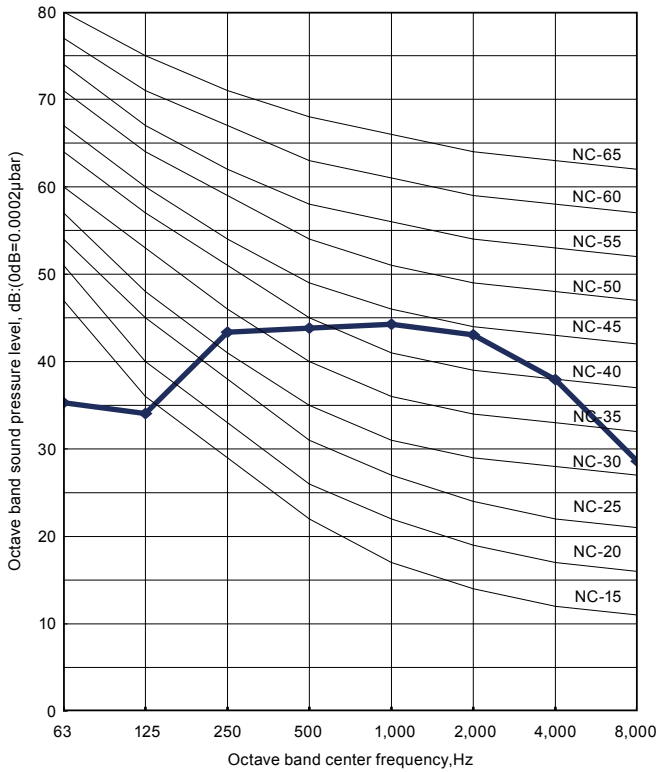

#### ● Heating

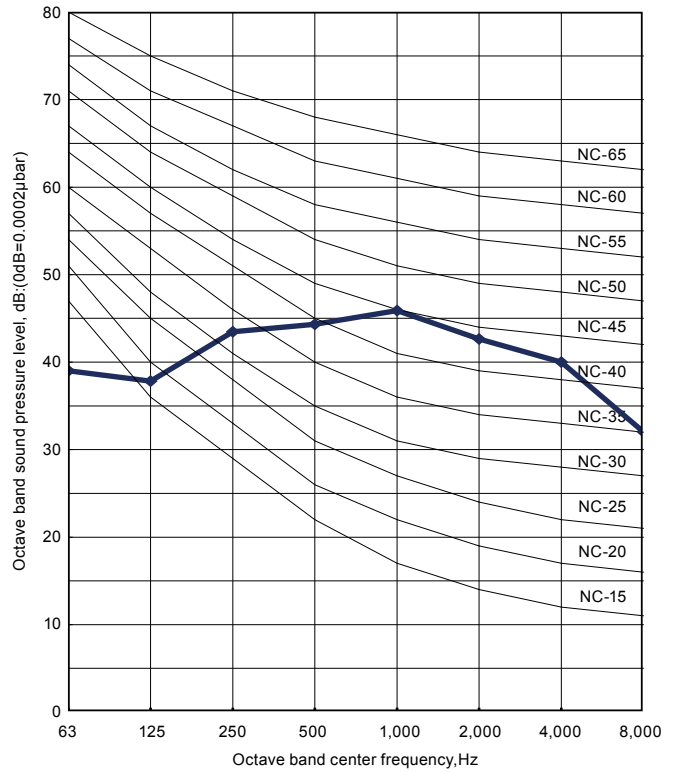

OUTDOOR UNIT  
AO\*G12-24LAL

OUTDOOR UNIT  
AO\*G12-24LAL

## MODEL: AO\*G18LALL

### ● Cooling

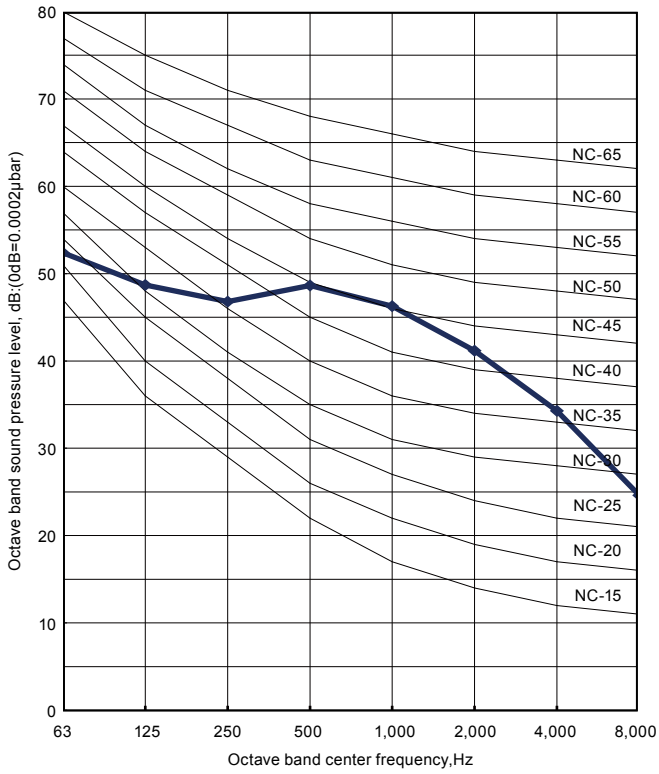

### ● Heating

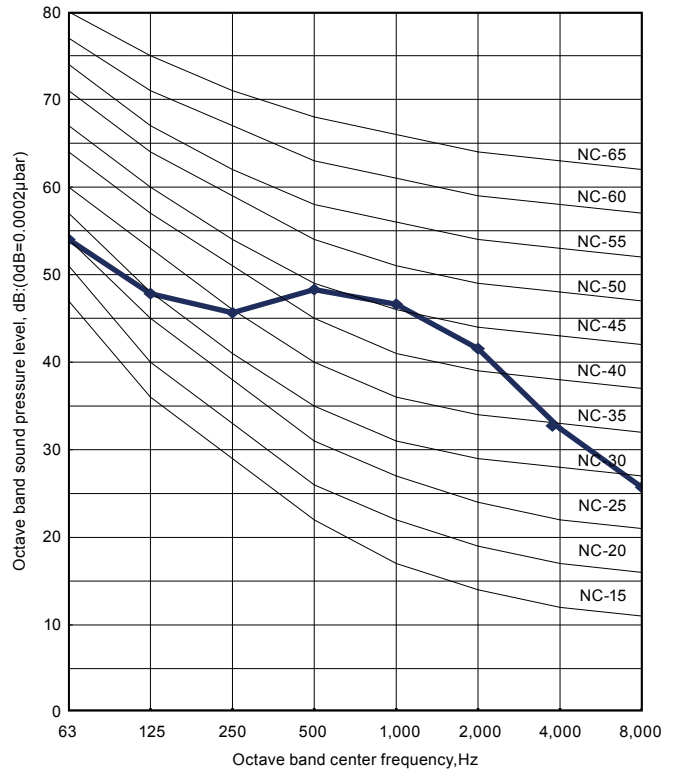

## MODEL: AO\*G24LALA

### ● Cooling

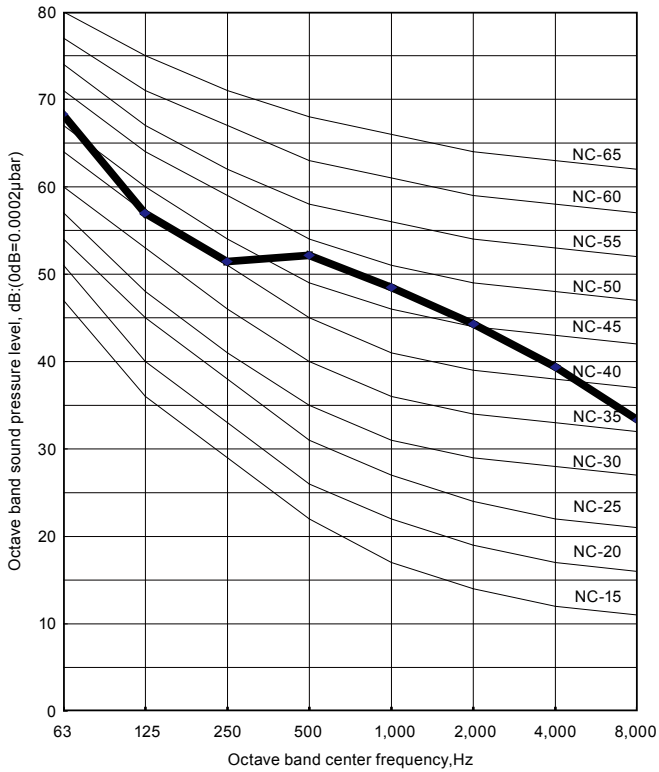

### ● Heating

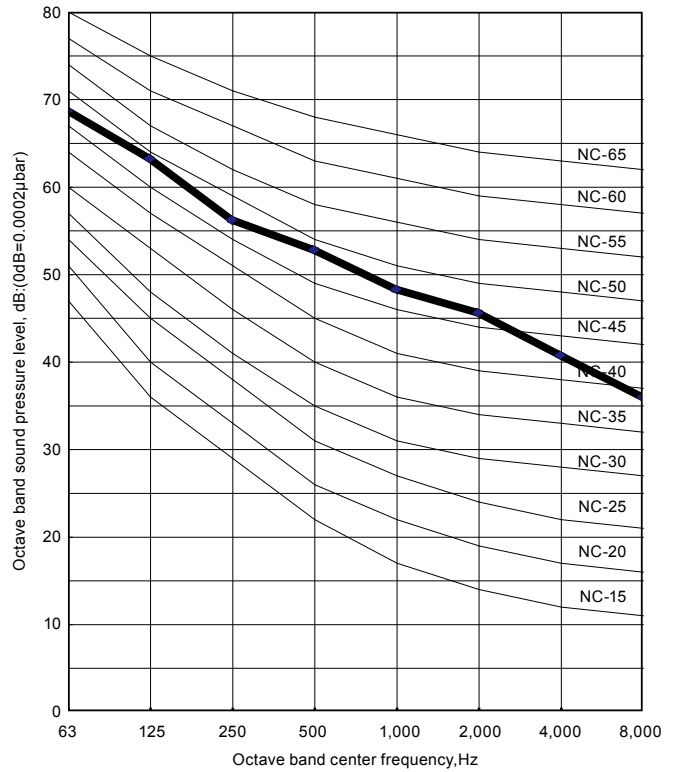



# 8-2. SOUND LEVEL CHECK POINT

OUTDOOR UNIT  
AO\*G12-24LAL

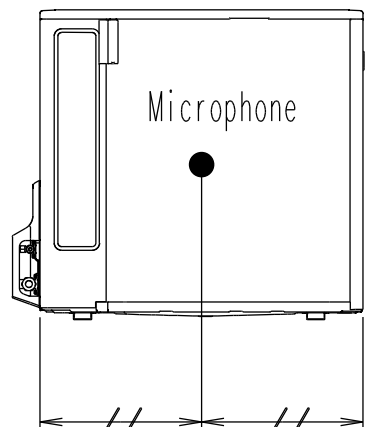
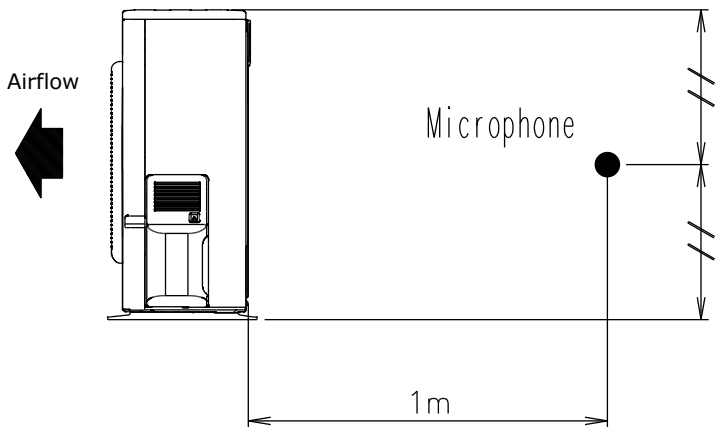

OUTDOOR UNIT  
AO\*G12-24LAL

## 9. ELECTRIC CHARACTERISTICS

Model name			AO*G12LALL	AO*G14LALL	AO*G18LALL	AO*G24LALA
Power supply	Voltage	V	230 ~			
	Frequency	Hz	50			
*1) Max operating current		A	10.0	12.5		13.5
Starting Current		A	5.1	6.1	7.4	9.9
*2) Wiring Spec.:	Main Fuse (Circuit breaker) Current	A	25			
	Power Cable	mm <sup>2</sup>	4.0			

\*1) The maximum current is the total current of indoor unit and outdoor unit.

\*2) Wiring Spec.:

Selected Sample

(Selected based on Japan Electrotechnical Standards and Codes Committee E0005)

# 10. SAFETY DEVICES

OUTDOOR UNIT  
AO\*G12-24LAL

OUTDOOR UNIT  
AO\*G12-24LAL

	Protection form	Model			
		AO*G12LALL	AO*G14LALL	AO*G18LALL	AO*G24LALA
Circuit protection	Current fuse (Near the terminal)	250V 20A			
		250V 5A			
	Current fuse (Main printed circuit board)	250V 15A			
		250V 3.15A			
Fan motor protection	Thermal protection program	OFF : 100 <sup>+15</sup> <sub>-10</sub> °C ON : 95 <sup>+15</sup> <sub>-10</sub> °C		OFF : 110 <sup>+15</sup> <sub>-10</sub> °C ON : 105 <sup>+15</sup> <sub>-10</sub> °C	
Compressor protection	Terminal protection program (Compressor temp.)	OFF : 110°C ON : After 40 minutes and 80°C or less			
	Thermal protection program (Discharge temp.)	OFF : 110°C ON : After 7 minutes			