

Duct Type SPLIT TYPE AIR CONDITIONER INSTALLATION INSTRUCTION SHEET (PART NO. 9374815050)

CAUTION
R410A REFRIGERANT
This Air Conditioner contains and operates with refrigerant R410A and Polyol Ester oil. THIS PRODUCT MUST ONLY BE INSTALLED OR SERVICED BY QUALIFIED PERSONNEL. Refer to Commonwealth, State, Territory and local legislation, regulations, codes, installation & operation manuals, before the installation, maintenance and/or service of this product.

Indoor unit is an appliance not accessible to the general public.

For authorized service personnel only.

DANGER	This mark indicates procedures which, if improperly performed, are most likely to result in the death or serious injury to the user or service personnel.
WARNING	This mark indicates procedures which, if improperly performed, might lead to the death or serious injury of the user.
CAUTION	This mark indicates procedures which, if improperly performed, might possibly result in personal harm to the user, or damage to property.

DANGER

Never touch electrical components immediately after the power supply has been turned off. Electrical shock may occur. After turning off the power, always wait 5 minutes or more before touching electrical components.

This air conditioner uses new refrigerant HFC (R410A).

The basic installation work procedures are the same as conventional refrigerant models. However, pay careful attention to the following points:

- Since the working pressure is 1.6 times higher than that of conventional refrigerant models, some of the piping and installation and service tools are special. (See the table below.) Especially, when replacing a conventional refrigerant model with a new refrigerant R410A model, always replace the conventional piping and flare nuts with the R410A piping and flare nuts.
- Models that use refrigerant R410A have a different charging port thread diameter to prevent erroneous charging with conventional refrigerant and for safety. Therefore, check beforehand. [The charging port thread diameter for R410A is 1/2 UNF 20 threads per inch.]
- Be more careful that foreign matter (oil, water, etc.) does not enter the piping than with refrigerant models. Also, when storing the piping, securely seal the openings by pinching, taping, etc.
- When charging the refrigerant, take into account the slight change in the composition of the gas and liquid phases, and always charge from the liquid phase side whose composition is stable.

Special tools for R410A

Tool name	Contents of change
Gauge manifold	Pressure is high and cannot be measured with a conventional gauge. To prevent erroneous mixing of other refrigerants, the diameter of each port has been changed. It is recommended the gauge with seals -0.1 to 5.3 MPa (-76 cmHg to 53 kgf/cm ²) for high pressure. -0.1 to 3.8 MPa (-76 cmHg to 38 kgf/cm ²) for low pressure.
Charge hose	To increase pressure resistance, the hose material and base size were changed.
Vacuum pump	A conventional vacuum pump can be used by installing a vacuum pump adapter.
Gas leakage detector	Special gas leakage detector for HFC refrigerant R410A.

Copper pipes

It is necessary to use seamless copper pipes and it is desirable that the amount of residual oil is less than 40 mg/10m. Do not use copper pipes having a collapsed, deformed or discolored portion (especially on the interior surface). Otherwise, the expansion valve or capillary tube may become blocked with contaminants. As an air conditioner using R410A incurs pressure higher than when using conventional refrigerant, it is necessary to choose adequate materials. Thicknesses of copper pipes used with R410A are as shown in the table. Never use copper pipes thinner than that in the table even when it is available on the market.

Thicknesses of Annealed Copper Pipes (R410A)		
Pipe outside diameter	Thickness	
6.35 mm (1/4 in.)	0.80 mm	
9.52 mm (3/8 in.)	0.80 mm	
12.70 mm (1/2 in.)	0.80 mm	
15.88 mm (5/8 in.)	1.00 mm	
19.05 mm (3/4 in.)	1.20 mm	

STANDARD PARTS

The following installation parts are furnished. Use them as required.

INDOOR UNIT ACCESSORIES

Name and Shape	Q'ty	Application
Installation template	1	For positioning the indoor unit
Hanger	4	For suspending the indoor unit from ceiling
Tapping screw (ø4 × 10)	8	For installing the hanger
Special nut A (large flange)	4	For suspending the indoor unit from ceiling
Special nut B (small flange)	4	For suspending the indoor unit from ceiling
Coupler heat insulation (large)	1	For indoor side pipe joint (gas pipe)
Coupler heat insulation (small)	1	For indoor side pipe joint (liquid pipe)
Edge cover	1	For making a wiring hole for connecting optional units. (Referring to 8 of this installation instruction sheet)

Name and Shape	Q'ty	Application
Binder	(Small) 1 (Large) 4	For remote controller and remote controller cord binding For fixing the coupler heat insulation
Remote controller	1	
Remote controller cord	1	For connecting the remote controller
Tapping screw (ø4 × 16)	2	For installing the remote controller
Filter	2	9000 BTU/h model
	3	12000 - 22000 BTU/h models
Drain hose insulation	1	Insulates the drain hose and vinyl hose connection

OPTIONAL PARTS

The following options are available.
• Remote sensor : UTD-RS100 (P/N 9072619004)

1 INDOOR UNIT INSTALLATION

WARNING

Install the air conditioner in a location which can withstand a load of at least five times the weight of the main unit and which will not amplify sound or vibration. If the installation location is not strong enough, the indoor unit may fall and cause injuries.

CAUTION

- For installation, refer to the technical data.
- To prevent people from touching the parts inside the unit, be sure to install grilles on the inlet and outlet ports. The grilles must be designed in such a way that cannot be removed without tools.

A. CEILING CONCEALED TYPE

1. INSTALL THE FILTERS

Install the filters to the unit.

[12000 - 22000 BTU/h models] [9000 BTU/h model]

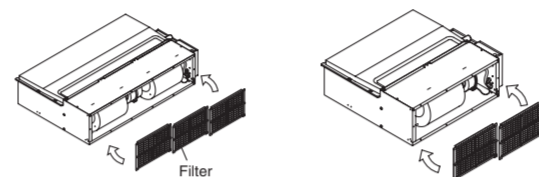

CAUTION

Fasten the unit securely with special nuts A and B.

4. LEVELING

Base horizontal direction leveling on top of the unit.

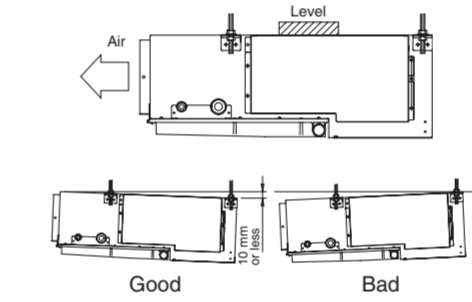
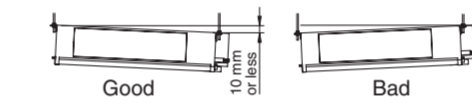
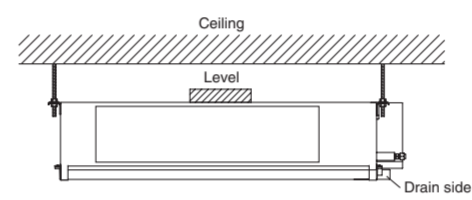

This unit may also be installed with the air inlet facing down. See also 1 - B - 1 for such cases.

2. DRILLING HOLES FOR BOLTS AND INSTALLING THE BOLTS

Using the installation template, drill holes for bolts (4 holes).

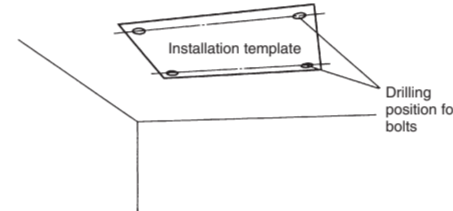

CONNECTING PIPE REQUIREMENT

CAUTION

Refer to the installation instruction sheet of the outdoor unit for description of the length of connecting pipe or for difference of its elevation.

MODEL	9000 and 12000 BTU/h models		14000 - 22000 BTU/h models	
	Liquid	Gas	Liquid	Gas
Diameter	6.35 mm (1/4 in.)	9.52 mm (3/8 in.)	6.35 mm (1/4 in.)	12.70 mm (1/2 in.)

• Use pipe with water-resistant heat insulation.

CAUTION

Install heat insulation around both the gas and liquid pipes. Failure to do so may cause water leaks. Use heat insulation with heat resistance above 120 °C. (Reverse cycle model only) In addition, if the humidity level at the installation location of the refrigerant piping is expected to exceed 70%, install heat insulation around the refrigerant piping. If the expected humidity level is 70-80%, use heat insulation that is 15 mm or thicker and if the expected humidity exceeds 80%, use heat insulation that is 20 mm or thicker. If heat insulation is used that is not as thick as specified, condensation may form on the surface of the insulation. In addition, use heat insulation with heat conductivity of 0.045 W/(m·K) or less (at 20 °C).

ELECTRICAL REQUIREMENT

• Electric wire size :

Connection cord (mm ²)	
MAX.	MIN.
2.5	1.5

- Use conformed cord with Type 245 IEC57.
- Install all electrical works in accordance to the standard.
- Install the disconnect device with a contact gap of at least 3 mm in all poles nearby the units. (Both indoor unit and outdoor unit)

SELECTING THE MOUNTING POSITION

WARNING

Install at a place that can withstand the weight of the indoor and outdoor units and install positively so that the units will not topple or fall.

CAUTION

- Do not install where there is the danger of combustible gas leakage.
- Do not install near heat sources.
- If children under 10 years old may approach the unit, take preventive measures so that they cannot reach the unit.
- Take precautions to prevent the unit from falling.

Decide the mounting position with the customer as follows:

INDOOR UNIT

- Install the indoor unit level on a strong wall, floor, ceiling which is not subject to vibration.
- The inlet and outlet ports should not be obstructed : the air should be able to blow all over the room.
- Install the unit near an electric outlet or special branch circuit.
- Do not install the unit where it will be exposed to direct sunlight.
- Install the unit where connection to the outdoor unit is easy.
- Install the unit where the drain pipe can be easily installed.
- Take servicing, etc. into consideration and leave the spaces shown on the right. Also install the unit where the filter can be removed.
- Install the indoor unit where vibrations and noise are not amplified.
- When installing the unit on the floor, provide an opening that will allow sufficient air to reach the air inlet panel.

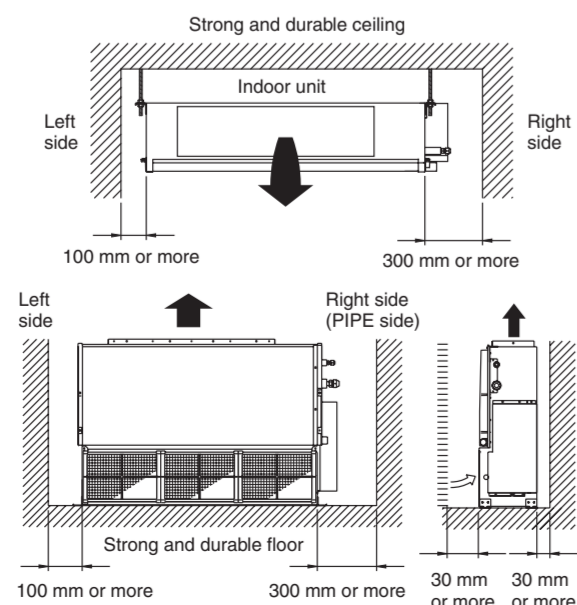

3. INSTALLING THE HANGERS

Fasten the hanging bolts to the ceiling and install special nuts A and B.

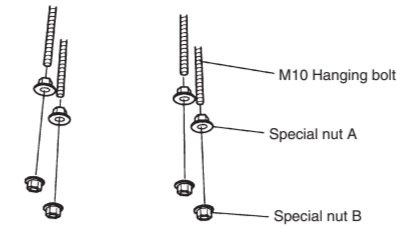

Install the hangers to the unit (4 places).

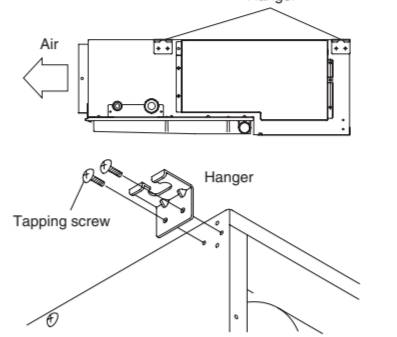

Hang the unit. Pass the hanging bolts through the hangers (4 places).

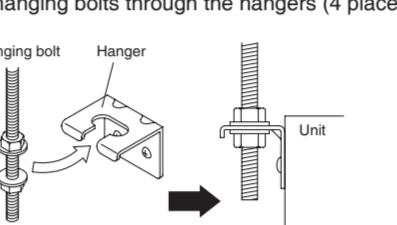

CAUTION

Fasten the unit securely with special nuts A and B.

5. MAINTENANCE HOLE DIMENSIONS

Open a maintenance hole with the dimensions shown.

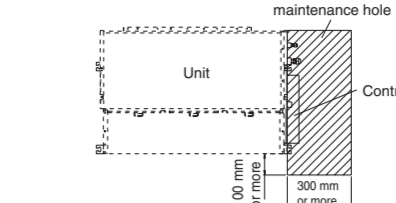

6. INTAKE DUCT CONNECTION

Follow the procedure in the following figure to the ducts.

[12000 - 22000 BTU/h models] [9000 BTU/h model]

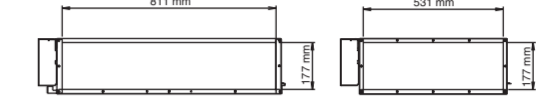

By changing the position of air inlet grille, the air inlet duct can be installed to the bottom. As shown in the following figure, remove the air inlet grille and install it on the rear side. (The factory setting is back air intake.)

[12000 - 22000 BTU/h models] [9000 BTU/h model]

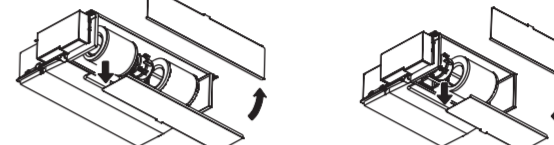

CAUTION

When air is taken in from the bottom side, the operating sound of the product will easily enter the room. Install the product and intake grilles where the affect of the operating sound is small.

CAUTION

- If an intake duct is installed, take care not to damage the temperature sensor (the temperature sensor is attached to the intake port flange).
- Be sure to install the air inlet grille and the air outlet grille for air circulation. The correct temperature cannot be detected.

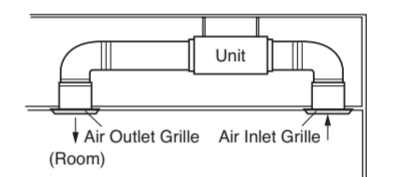

CAUTION

- Grilles must be fixed so that man cannot touch indoor unit fan, and cannot be removed by only hand operation without tool.
- Be sure to install the air filter in the air inlet. If the air filter is not installed, the heat exchanger may be clogged and its performance may decrease.

B. FLOOR STANDING CONCEALED TYPE

1. INSTALL THE FILTERS

- Remove the 4 tapping screws, and then remove cover.
- Install the cover with the 4 tapping screws as shown in the illustration below.

[12000 - 22000 BTU/h models] [9000 BTU/h model]

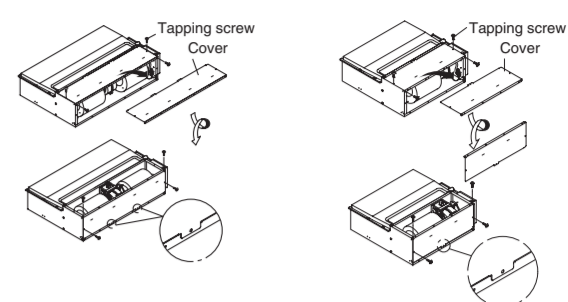

Install the filters to the unit referring to 1 - A - 1.

[12000 - 22000 BTU/h models] [9000 BTU/h model]

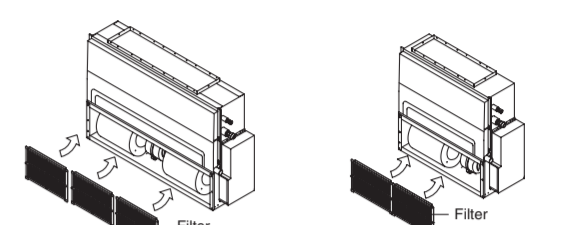

2. INSTALLING THE HANGERS

Install the hangers to the unit (4 places).

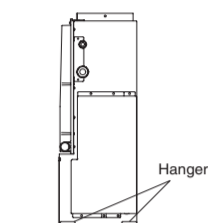

3. DRILLING HOLES FOR BOLTS AND INSTALLING THE BOLTS

Drilling position for bolts.

[12000 - 22000 BTU/h models]

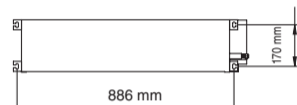

[9000 BTU/h model]

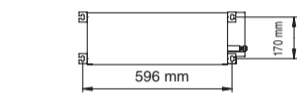

CAUTION

Secure with an M10 anchor bolts. If securing the unit to the floor is difficult, first build a stand or platform.

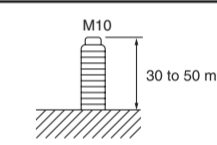

4. INSTALL THE UNIT

Fix the unit. Install the unit and fasten with special nut B.

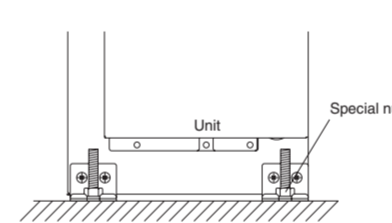

5. LEVELING

Base horizontal and vertical direction leveling on top of the unit.

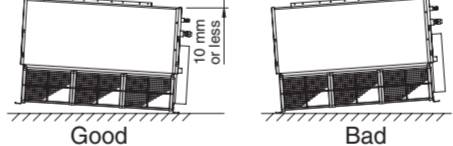
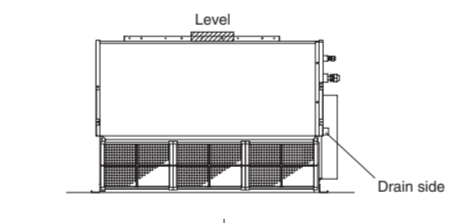

CAUTION

In order to prevent water from leaking around the outlet port, make sure to insulate it (on both the CEILING CONCEALED type and the FLOOR STANDING CONCEALED type).

NOTE: INSTALLING DRAIN HOSE

CAUTION

Install the drain hose in accordance with the instructions in this installation instruction sheet and keep the area warm enough to prevent condensation. Problems with the piping may lead to water leaks.

INSTALL THE DRAIN HOSE

- Install the drain hose with downward gradient (1/50 to 2/50) and so there are no rises or traps in the hose.
- Use general hard polyvinyl chloride pipe and connect it with adhesive (polyvinyl chloride) so that there is no leakage.
- When the hose is long, install supporters.
- Do not perform air bleeding.
- Always heat insulate the indoor side of the drain hose.
- When the unit is shipped from the factory, the drain port is on the right side (control box side).
- When using the drain port on the left side of the unit, remove the drain cap and install it to the right side drain port.

A. CEILING CONCEALED TYPE

Arrange the drain hose lower than this portion.

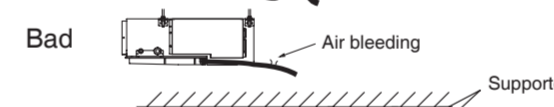
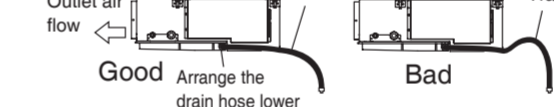

B. FLOOR STANDING CONCEALED TYPE

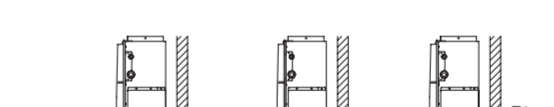

CAUTION

- Install the drain hose so that the control box cover can be removed for servicing.
- In order to prevent water from leaking into the control box, make sure that the drain hose is well insulated.
- After the wiring is connected and installation of the piping and drain hose is complete, make a seal around the opening in the wall.
- Make sure that the drain cap is securely installed onto the unused drain port. If the drain cap is not installed correctly, water may drip during the cooling operation.

The out side diameter of drain port is 26 mm, use a suitable drain hose.

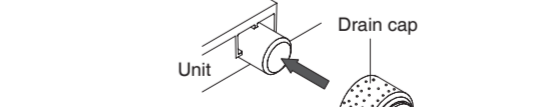
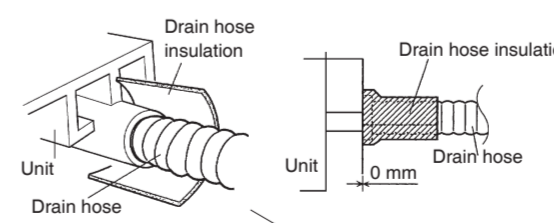

2 CONNECTING THE PIPING

CAUTION

- Do not use mineral oil on flared part. Prevent mineral oil from getting into the system as this would reduce the lifetime of the units.
- While welding the pipes, be sure to blow dry nitrogen gas through them.
- The maximum lengths of this product are shown in the table. If the units are further apart than this, correct operation can not be guaranteed.

1. FLARING

- Cut the connection pipe to the necessary length with a pipe cutter.
- Hold the pipe downward so that cuttings will not enter the pipe and remove the burrs.
- Insert the flare nut (always use the flare nut attached to the indoor and outdoor units respectively) onto the pipe and perform the flare processing with a flare tool. Use the special R410A flare tool, or the conventional flare tool.

Check if [1] is flared uniformly and is not cracked or scratched.

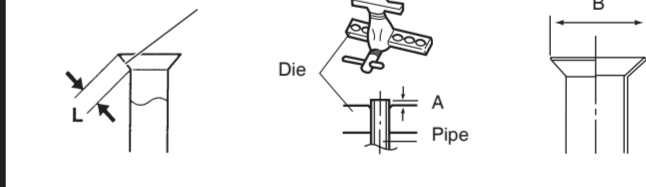

Pipe outside diameter	Dimension A (mm)	
	Flare tool for R410A, clutch type	
6.35 mm (1/4 in.)	0 to 0.5	
9.52 mm (3/8 in.)		
12.70 mm (1/2 in.)		
15.88 mm (5/8 in.)		
19.05 mm (3/4 in.)		

Pipe outside diameter	Dimension B 3/4 (mm)
6.35 mm (1/4 in.)	9.1
9.52 mm (3/8 in.)	13.2
12.70 mm (1/2 in.)	16.6
15.88 mm (5/8 in.)	19.7
19.05 mm (3/4 in.)	24.0

When using conventional flare tools to flare R410A pipes, the dimension A should be approximately 0.5 mm more than indicated in the table (for flaring with R410A flare tools) to achieve the specified flaring. Use a thickness gauge to measure the dimension A.

Pipe outside diameter	Width across flats of Flare nut
6.35 mm (1/4 in.)	17 mm
9.52 mm (3/8 in.)	22 mm
12.70 mm (1/2 in.)	26 mm
15.88 mm (5/8 in.)	29 mm
19.05 mm (3/4 in.)	36 mm

2. BENDING PIPES

The pipes are shaped by your hands. Be careful not to collapse them. Do not bend the pipes in an angle more than 90°. When pipes are repeatedly bend or stretched, the material will harden, making it difficult to bend or stretch them any more. Do not bend or stretch the pipes more than three times.

CAUTION

- To prevent breaking of the pipe, avoid sharp bends. Bend the pipe with a radius of curvature of 150 mm or over.
- If the pipe is bent repeatedly at the same place, it will break.

3. CONNECTION PIPES

Indoor unit

(1) Detach the caps and plugs from the pipes.

CAUTION

- Be sure to apply the pipe against the port on the indoor unit correctly. If the centering is improper, the flare nut cannot be tightened smoothly. If the flare nut is forced to turn, the threads will be damaged.
- Do not remove the flare nut from the indoor unit pipe until immediately before connecting the connection pipe.

(2) Centering the pipe against port on the indoor unit, turn the flare nut with your hand.

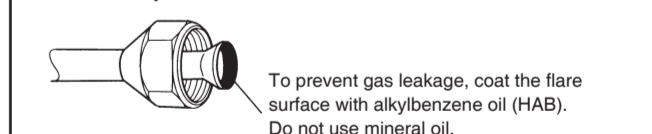

(3) When the flare nut is tightened properly by your hand, use a torque wrench to finally tighten it.

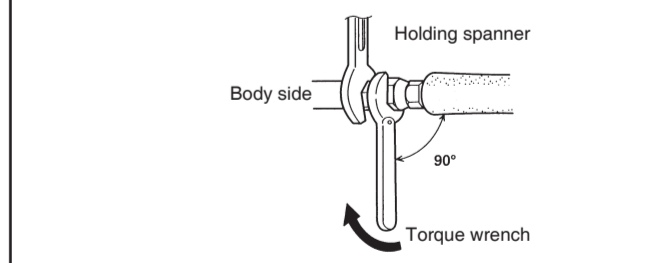

CAUTION

Hold the torque wrench at its grip, keeping it in the right angle with the pipe, in order to tighten the flare nut correctly.

Flare nut	Tightening torque
6.35 mm (1/4 in.) dia.	16 to 18 N·m (160 to 180 kgf·cm)
9.52 mm (3/8 in.) dia.	30 to 42 N·m (300 to 420 kgf·cm)
12.70 mm (1/2 in.) dia.	49 to 61 N·m (490 to 610 kgf·cm)
15.88 mm (5/8 in.) dia.	63 to 75 N·m (630 to 750 kgf·cm)
19.05 mm (3/4 in.) dia.	90 to 110 N·m (900 to 1100 kgf·cm)

2 CONNECTING THE PIPING

• Lay the piping

A. CEILING CONCEALED TYPE

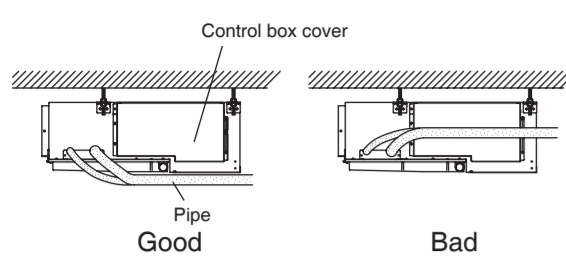

B. FLOOR STANDING CONCEALED TYPE

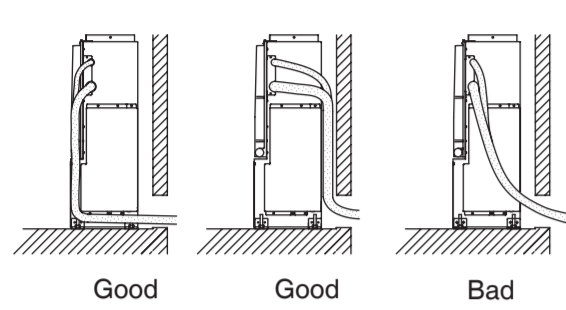

CAUTION

- Install the piping so that the control box cover can be removed for servicing.
- In order to prevent water from leaking into the control box, make sure that the piping is well insulated.

4. HEAT INSULATION ON THE PIPE JOINTS (INDOOR SIDE ONLY)

- After checking for gas leaks, insulate by wrapping insulation around the two parts (large and small) of the indoor unit coupling, using the coupler heat insulation.
- After installing the coupler heat insulation, wrap both ends with vinyl tape so that there is no gap.
- After wrapping tape around the ends of the coupler heat insulation, secure the heat insulation pipe and the taped portion with large binders in two places, as shown below.

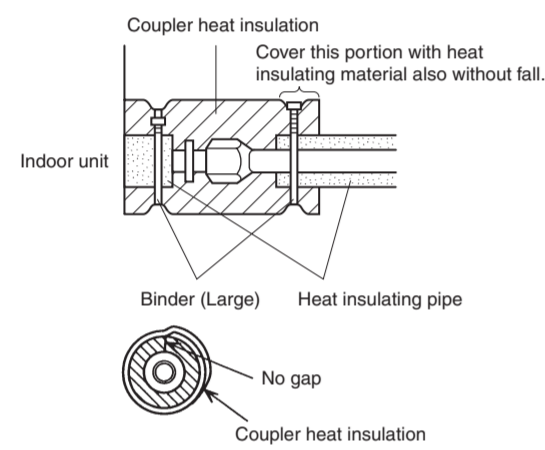

3 ELECTRICAL WIRING

WARNING

- Before starting work, check that power is not being supplied to the indoor unit and outdoor unit.
- Match the terminal board numbers and connection cord colors with those of the outdoor unit. Erroneous wiring may cause burning of the electric parts.
- Connect the connection cords firmly to the terminal board. Imperfect installation may cause a fire.
- Always fasten the outside covering of the connection cord with the cord clamp. (If the insulator is chafed, electric leakage may occur.)
- Always connect the ground wire.
- Install the remote controller wires so as not to be direct touched with your hand.

HOW TO CONNECT WIRING TO THE TERMINALS

For strand wiring

- Cut the wire end with a wire cutter or wire-cutting pliers, then strip the insulation to about 10 mm of expose the strand wiring.
- Using a screwdriver, remove the terminal screw(s) on the terminal board.
- Using a round terminal fastener or pliers, securely clamp a round terminal to each stripped wire end.
- Position the round terminal wire, and replace and tighten the terminal screw using a screwdriver.

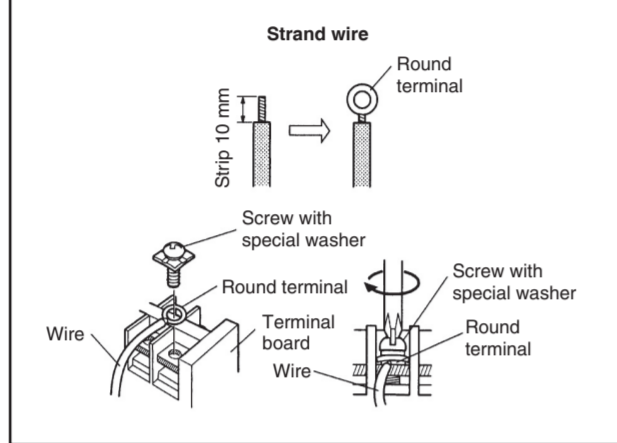

CAUTION

Do not bundle the remote controller cord, or wire the remote controller cord in parallel, with the indoor unit connection wire (to the outdoor unit) and the power supply cord. It may cause erroneous operation.

1. CONNECTION DIAGRAMS

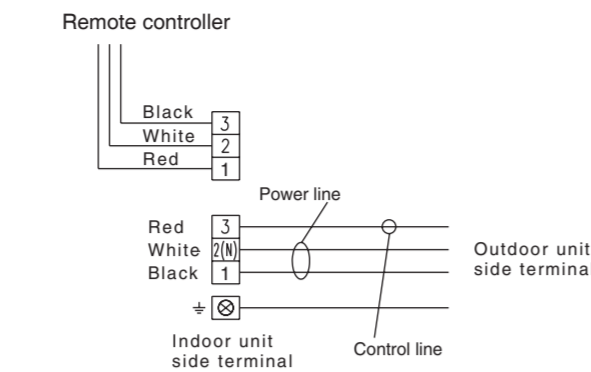

2. CONNECTION CORD PREPARATION

Keep the earth wire longer than the other wires.



- Use a 4-core wire cord.

3. INDOOR UNIT SIDE

CAUTION

Use care not to mistake the power supply cord and connection wires when installing.

- Remove the control box cover from the control box.

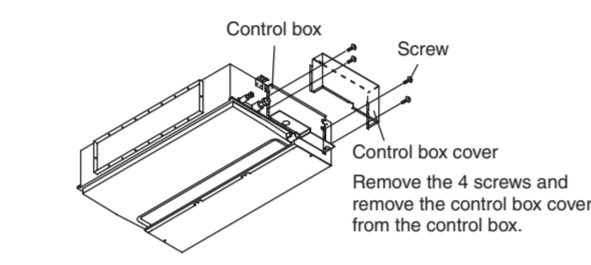

- Cord connection.
 - Clamp the connection cord with the cord clamp.
 - Connect the connection cord to the terminal board.
 - Clamp the remote controller cord with nylon clamp.
 - Connect the remote controller cord to the terminal board.

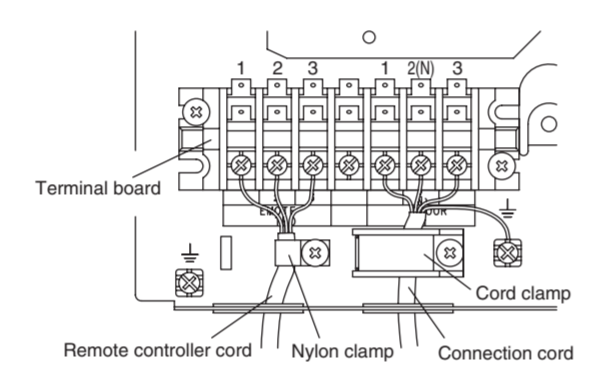

CAUTION

- Tighten the indoor unit connection cord (to the outdoor unit) and power supply indoor and outdoor unit terminal board connections firmly with the terminal board screws. Faulty connection may cause a fire.
- If the indoor unit connection cord (to the outdoor unit) and power supply are wired incorrectly, the air conditioner may be damaged.
- Wire the indoor unit connection cord (to the outdoor unit) by matching the numbers of the outdoor and indoor units terminal board numbers as shown in terminal label.
- Ground both the indoor and outdoor units by attaching a ground wire.
- Unit shall be grounded in compliance with the applicable local and national codes.

4. Floor standing concealed/ceiling concealed select switch

- The DIP switches were set for use as a ceiling concealed type at the factory.
- The following changes must be made to the settings if the unit is to be used as a floor standing concealed type.
- Changing the settings for the electrical circuits. DIP Switch 1 (SW1) on the printed circuit board inside the electric component box must be set as follows.

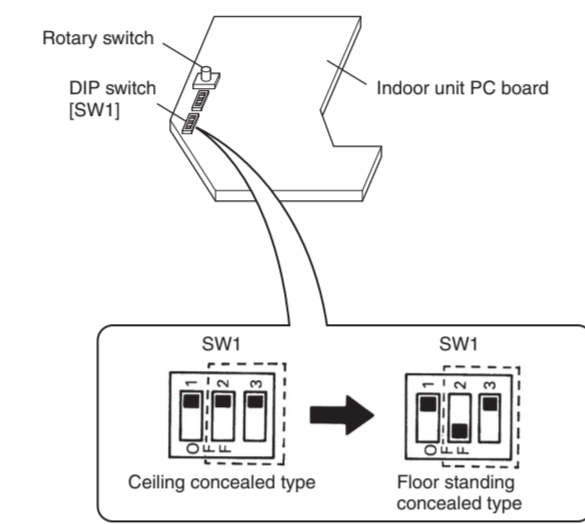

5 TEST RUNNING

CAUTION

Always turn on the power 12 hours prior to the start of the operation in order to ensure compressor protection.

- Stop the air conditioner operation.
- Press the master control button and the fan control button simultaneously for 2 seconds or more to start the test running.

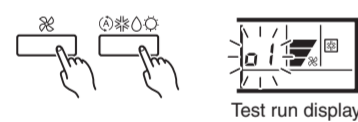

- Press the start/stop button to stop the test running.

[SELF-DIAGNOSIS]

When the error indication "E.EE" is displayed, follow the following items to perform the self-diagnosis. "E.EE" indicates an error has occurred.

1. REMOTE CONTROLLER DISPLAY

- Stop the air conditioner operation.
- Press the set temperature buttons Δ / ∇ simultaneously for 5 seconds or more to start the self-diagnosis. Refer to the following tables for the description of each error code.

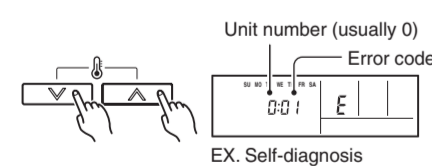

- Press the set temperature buttons Δ / ∇ simultaneously for 5 seconds or more to stop the self-diagnosis.

Error code	Error contents
00	Communication error (indoor unit \leftrightarrow remote controller)
01	Communication error (outdoor unit \leftrightarrow indoor unit)
02	Room temperature sensor open
03	Room temperature sensor short-circuited
04	Indoor heat exchanger temperature sensor open
05	Indoor heat exchanger temperature sensor short-circuited
06	Outdoor heat exchanger temperature sensor
08	Power source connection error
09	Float switch operated
0A	Outdoor temperature sensor
0c	Discharge pipe temperature sensor
11	Model abnormal
12	Indoor fan abnormal
13	Outdoor signal abnormal
14	Outdoor EEPROM abnormal
15	Compressor temperature sensor
16	Pressure switch abnormal
17	IPM error
1A	Compressor cannot operate
1b	Outdoor fan abnormal

6 AIR FLOW SETTING

Static range is 0 to 40 Pa. If static pressure is over 20 Pa, we recommend High static mode. High static and Normal mode. If select the High static mode, air flow increases. About 9000 BTU model and 22000 BTU model, High static mode and normal mode are same air flow. The air flow is set according to the DIP switch settings in the following tables.

[12000 - 18000 BTU/h models]

Fan mode	DIP-SW4		
	1	2	3
Normal mode (0 ≤ Pa ≤ 20)	—	OFF	OFF
High static pressure mode (20 < Pa ≤ 40)	—	ON	OFF

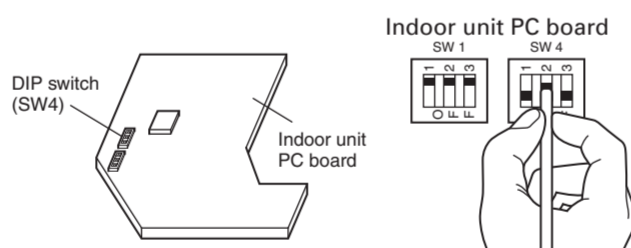

CAUTION

Do not set any switches other than those specified in this sheet. The air conditioner may not operate correctly if any switches other than those specified are changed.

4 REMOTE CONTROLLER SETTING

CAUTION

- In order to detect the room temperature correctly when using the temperature sensor of the remote controller, do not install the remote controller in a place where it will be exposed to direct sunlight or directly below the air outlet of the indoor unit.
- When installing the remote controller and cord near a source of electromagnetic waves, separate the remote controller from the source of the electromagnetic waves and use shielded cord.
- Do not touch the remote controller PC board and PC board parts directly with your hands.

1. INSTALLING THE REMOTE CONTROLLER

- Open the operation panel on the front of the remote controller, remove the two screws indicated in the following figure, and then remove the front case of the remote controller.

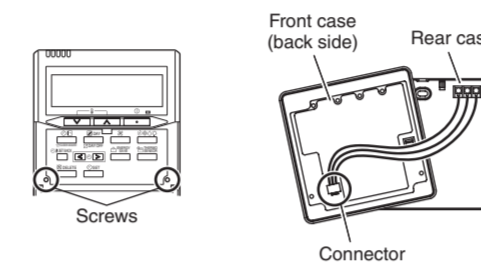

When installing the remote controller, remove the connector from the front case. The wires may break if the connector is not removed and the front case hangs down. When installing the front case, connect the connector to the front case.

- Install the rear case to the wall, etc. with the two tapping screws. Refer to the following information to install the remote controller wires.

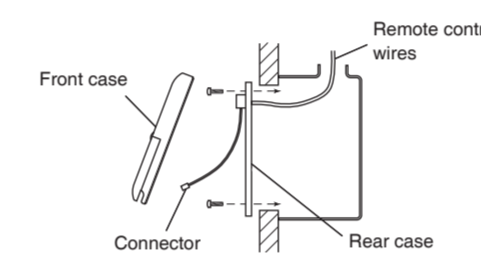

Install the remote controller wires so as not to be direct touched with your hand.

2. ROUTING THE REMOTE CONTROLLER WIRES

- Install the remote controller wires to the terminals on the top of the rear case as shown in the following figure.
- Fasten the wires with the binder.

(Example)

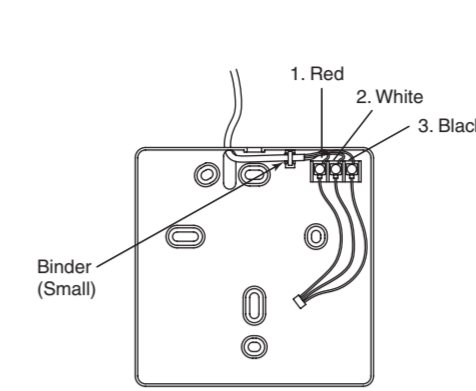

3. SETTING THE DIP SWITCHES When using a battery (memory backup)

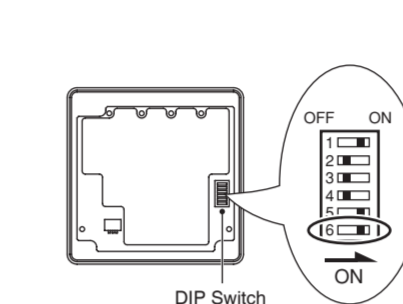

Change the DIP switch setting to use batteries. (The DIP switch is not set to use batteries at the factory.) Change DIP switch No. 6 from OFF to ON. If batteries are not used, all of the settings stored in memory will be deleted if there is a power failure.

- Press the THERMO SENSOR button for 5 seconds or more to unlock the function. The thermo sensor display flashes and then disappears when the function is unlocked.
- Press the THERMO SENSOR button. The thermo sensor display appears.
- Press the THERMO SENSOR button again for 5 seconds or more to lock the function. The thermo sensor display flashes and then remains on when the function is locked.
- Make sure that the function is locked.

4. SETTING THE ROOM TEMPERATURE DETECTION LOCATION

The detection location of the room temperature can be selected from the following three examples. Choose the detection location that is best for the installation location.

A. Indoor unit setting (factory setting)

The room temperature is detected by the indoor unit temperature sensor.

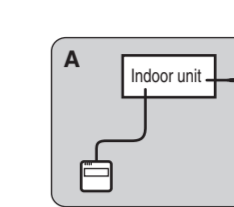

- When the THERMO SENSOR button is pressed, the lock display flashes because the function is locked at the factory.

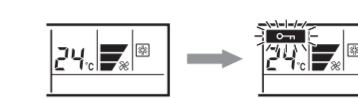

B. Remote controller setting

The room temperature is detected by the remote controller temperature sensor.

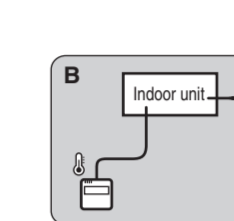

- Press the THERMO SENSOR button for 5 seconds or more to unlock the function. The thermo sensor display flashes and then disappears when the function is unlocked.
- Press the THERMO SENSOR button. The thermo sensor display appears.
- Press the THERMO SENSOR button again for 5 seconds or more to lock the function. The thermo sensor display flashes and then remains on when the function is locked.
- Make sure that the function is locked.

C. Indoor unit/remote controller setting (room temperature sensor selection)

The temperature sensor of the indoor unit or the remote controller can be used to detect the room temperature.

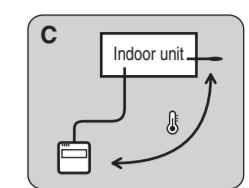

- Press the THERMO SENSOR button for 5 seconds or more to unlock the function. The thermo sensor display flashes and then disappears when the function is unlocked.
- Press the THERMO SENSOR button to select the temperature sensor of the indoor unit or the remote controller.

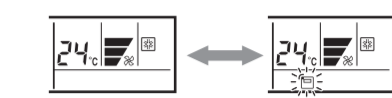

NOTES

If the function to change the temperature sensor is used as shown in examples A and B (other than example C), be sure to lock the detection location. If the function is locked, the lock display will flash when the THERMO SENSOR button is pressed.

7 SPECIAL INSTALLATION METHODS

CAUTION

- When setting the rotary switch and DIP switches, do not touch any other parts on the circuit board directly with your bare hands.
- Be sure to turn off the main power.

1. GROUP CONTROL SYSTEM

A number of indoor units can be operated at the same time using a single remote controller.

- Wiring method (indoor unit to remote controller)

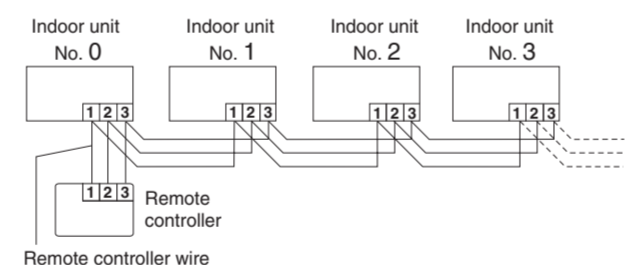

- Rotary switch setting (indoor unit) Set the unit number of each indoor unit using the rotary switch on the indoor unit circuit board. The rotary switch is normally set to 0.
- DIP switch setting (remote controller) Change DIP switch No. 3 on the remote controller from OFF to ON.

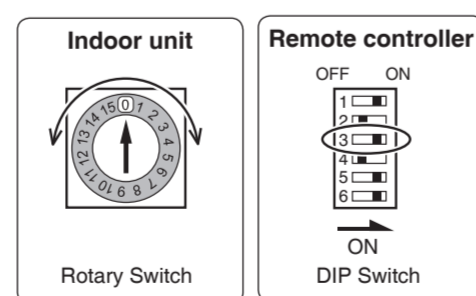

2. DUAL REMOTE CONTROLLERS (OPTIONAL)

Two separate remote controllers can be used to operate the indoor units.

- Wiring method (indoor unit to remote controller)

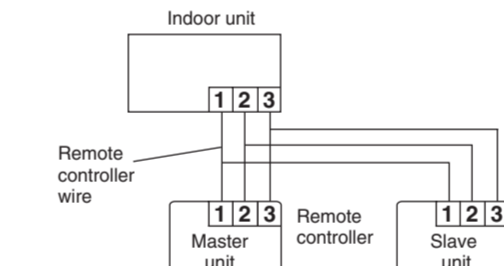

- DIP switch setting (remote controller) Set the remote controller DIP switch Nos. 1 and 2 according to the following table.

Number of remote controllers	Master unit		Remote controller
	DIP-SW No. 1	DIP-SW No. 2	
1 (Normal)	ON	OFF	OFF
2 (Dual)	OFF	OFF	ON

Number of remote controllers	Slave unit		DIP-Switch
	DIP-SW No. 1	DIP-SW No. 2	
1 (Normal)	—	—	OFF
2 (Dual)	ON	ON	ON

8 WHEN CONNECTING OPTIONAL UNITS

Remove the hole cover, install the edge cover, and then connecting with wiring.

CAUTION

- Do not scratch the printed circuit board during installation or removal.
- Edge cover can be installed from the printed circuit board side only.

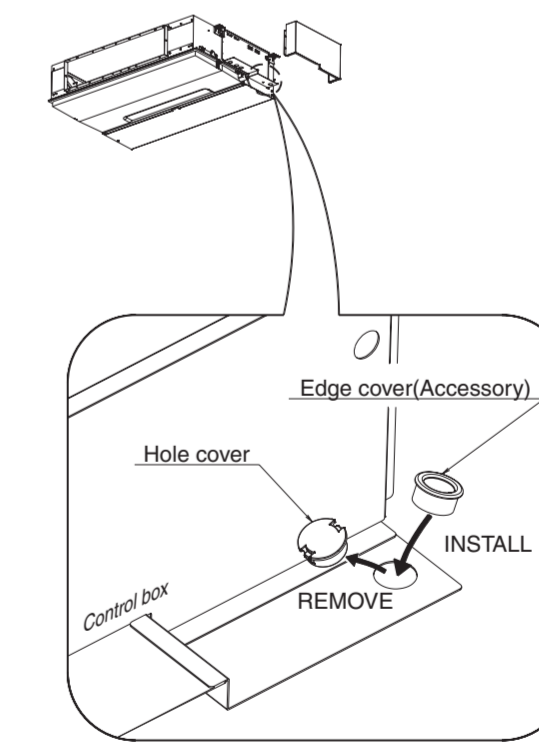

After installation, it is as shown below.

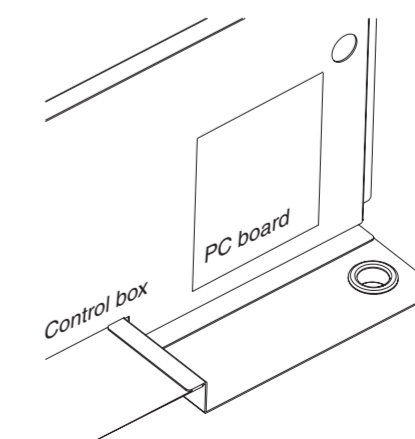

9 CUSTOMER GUIDANCE

Explain the following to the customer in accordance with the operating manual.

- Starting and stopping method, operation switching, temperature adjustment, timer, air flow switching, and other remote control unit operations.
- Air filter removal and cleaning.
- Give the operating and installation manuals to the customer.