

INDOOR UNIT

1. CASSETTE TYPE :

AU * A12LAL

AU * F12LAL

AU * A14LAL

AU * F14LAL

1. FEATURE

■ MODEL :

INDOOR UNIT	OUTDOOR UNIT	
AU* A12LAL	AO* A12LA CL	AO* B12LA CL
AU* F12LAL	AO* A12LALL	AO* B12LALL
AU* A14LAL	AO* A14LA CL	AO* B14LA CL
AU* F14LAL	AO* A14LALL	AO* B14LALL



■ FEATURES

● Energy saving

- All DC design
- Heat exchange efficiency increased and larger air flow by adoption of new type turbo fan

● Advancement in comfort

- Quiet operation was realized by adoption of new type turbo fan
- Improvement of air stream

● Improvement of installation & maintenance

- COMPACT DESIGN

Fits the European size ceiling.

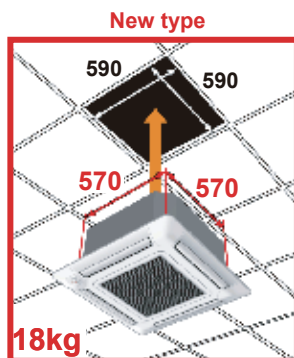

● Easy maintenance

① Maintenance of fan motor and fan

Maintenance of fan motor and fan can be done easily after taking off the panel, since bell-mouth can be removed easily

A : Fan motor

B : 2 stage turbo fan

C : Bell-mouth

D : Panel

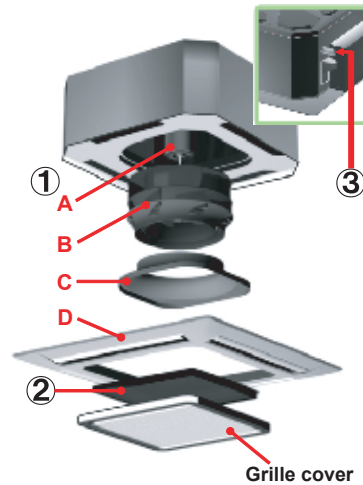

② Long life filter

: standard equipment

③ Adaptation of transparent drainage parts

Easy check of operation of drain-up kit when you install

● Easy installation

New type

Easy setting by wireless or wired remote controller

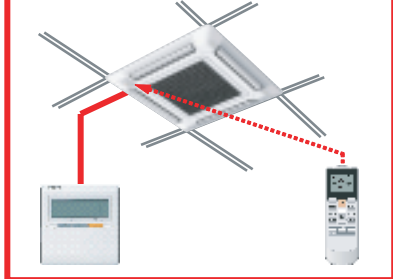

FUNCTION SETTING

● Outlet direction selection

- Performs operation matched to the number of outlets when 4 directions are unnecessary and outlets are blocked when the ceiling cassette is installed in a corner, etc.

4-way direction 3-way direction



4-way direction mode: Set when there are 4 outlets (shipped state).

3-way direction mode: Set when there are 3 outlets.

● Ceiling switching function

Air reaches sufficiently up to 3m height, even it is compact cassette type.

Also delivers air to high ceilings by selecting the mode and raising the air flow according to the height of the ceiling.

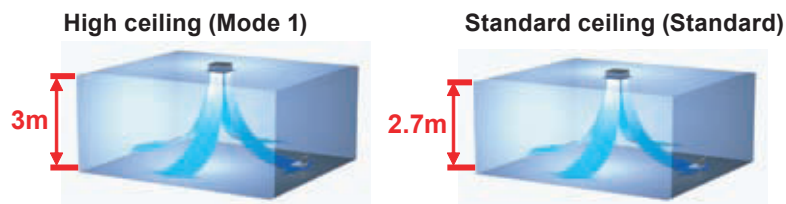

Standard...Operates at normal air flow.

Mode 1 ...Air flow becomes greater than normal.

● Filter sign

The indoor unit has sign to inform the user that it is time to clean the filter

● Cooling room temperature correction

● Heating room temperature correction

● Auto restart

The units restart automatically when the current was returned even when there was a power interruption during operation.

● Room temperature sensor switching

Switches from room temperature judgment by room temperature sensor attached to indoor unit body to room temperature judgment by room temperature sensor attached to wired remote controller.

● Economy operation

The power consumption can be reduced.

Powerful mode ...Standard

Soft mode ...Performs operation which reduces the power consumption

2. REMOTE CONTROLLER

WIRELESS REMOTE CONTROLLER

FEATURES



- * Four kinds of timer setup (ON / OFF / PROGRAM / SLEEP) are possible.
- * Four kinds of timers. Easy operation.
- * Easy to change transmission code (4 patterns) by button operation.

● Simple function setting

Setting of the air conditioner selection function is performed by remote controller.

● Built-in timers

Select from four different timer programs (On/Off/Program/Sleep).

● Program timer

The program timer operates the ON and OFF timer once within a 24 hour period.

● Sleep timer

The sleep timer function automatically corrects the temperature thermostat setting according to the time setting to prevent excessive cooling and heating while sleeping.

Cooling operation/dry operation

When the sleep timer is set, the set temperature automatically rises 1 °C every hour. The set temperature can rise up to a maximum of 2 °C.

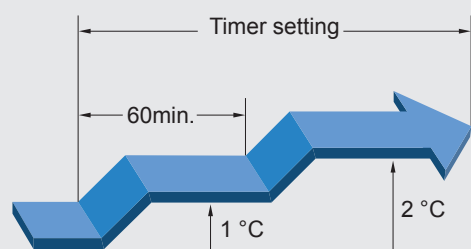

Heating operation

When the sleep timer is set, the set temperature automatically drops 1 °C every 30 minutes. The set temperature can drop to a maximum of 4 °C.

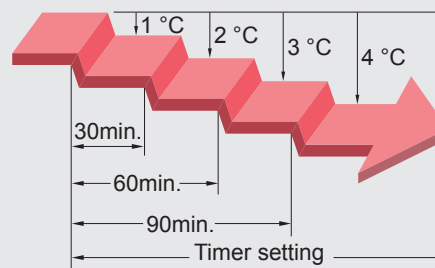

● Switching remote control unit signal code

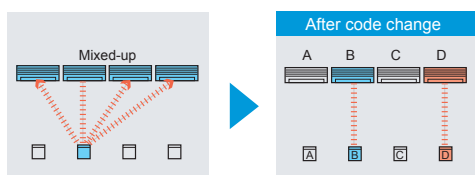

- Code selector switch eliminates unit being wrongly switched.
(Up to 4 codes can be set.)

FUNCTIONS

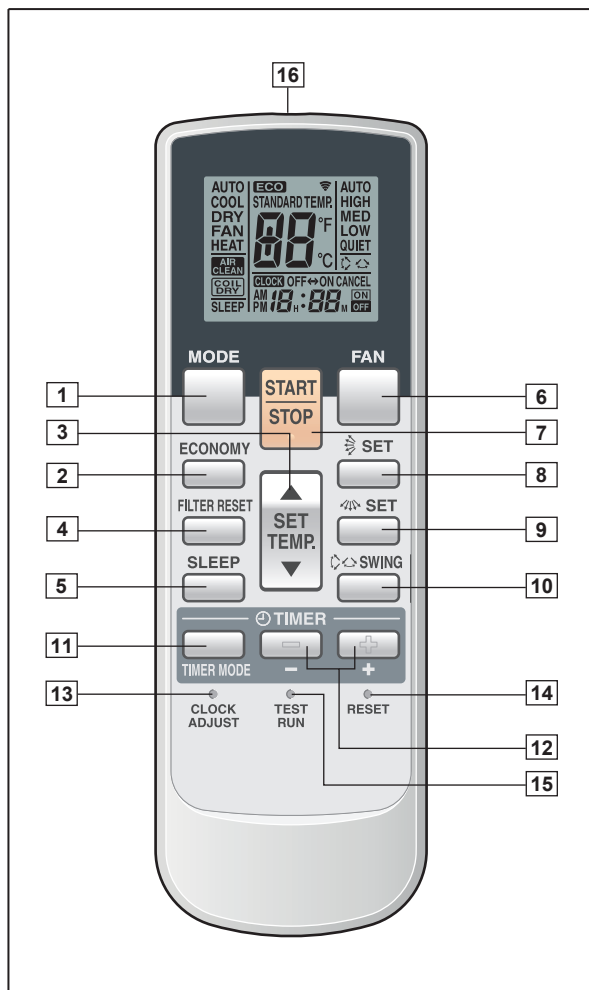

- 1 **MODE button**
Selects the operating mode (AUTO, HEAT, FAN, COOL, DRY).
/Start / end R.C. custom code change. (Max 4 types)
- 2 **Economy button**
- 3 **Set temp. button (▲/▼)**
Set remote controller custom code buttons
Sets the indoor temp./ Sets R.C. custom code.
- 4 **Filter reset button**
- 5 **Sleep button**
Pressed to select sleep timer.
- 6 **Fan button**
Selects the fan speed (AUTO, QUIET, LOW, MED, HIGH).
- 7 **START/STOP button**
Pressed to start and stop operation.
- 8 **Set button (Vertical)**
Air flow direction vertical set button.
- 9 **Set button (Horizontal)**
Air flow direction horizontal set button.
- 10 **Swing button**
Air flow direction swing button.
- 11 **Timer mode button**
Pressed to select the timer mode. (OFF TIMER, ON TIMER, PROGRAM TIMER, TIMER RESET)
- 12 **Timer set (⊕ / ⊖) button**
Sets the current time and on-off time.
- 13 **Clock adjust button**
Sets the current time.
- 14 **Reset button**
Used when replacing batteries.
- 15 **Test run button**
Used when testing the air conditioner after installation.

Display panel

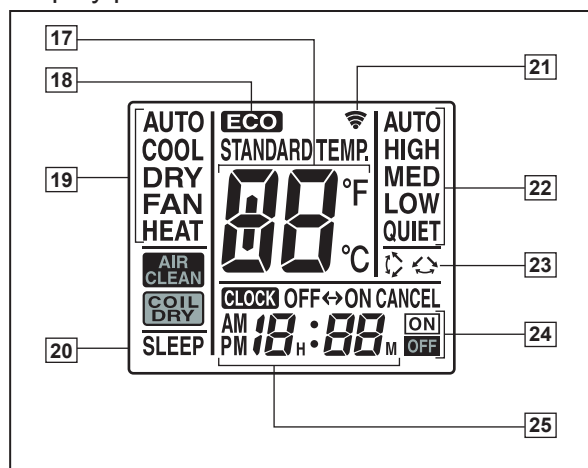

- 16 **Signal transmitter**
- 17 **Temperature set display**
- 18 **Economy display**
- 19 **Operating mode display**
- 20 **Sleep display**
- 21 **Transmit indicator**
- 22 **Fan speed display**
- 23 **Swing display**
- 24 **Timer mode display**
- 25 **Clock display**

Functions will be different due to type of indoor unit.
For details, please see operation manual.

SPECIFICATION

SIZE (H x W x D mm)	170 x 56 x 19
WEIGHT (g)	85 (w/o batteries)
ACCESSORY	Holder

3. SPECIFICATIONS

Type				CASSETTE MODEL		
				INVERTER HEATPUMP		
Model name				AU * A12LAL, AU * F12LAL	AU * A14LAL, AU * F14LAL	
				AO * A12LACL, AO * A12LALL	AO * A14LACL, AO * A14LALL	
Power source				230V ~ 50Hz		
Available voltage range				198-264V ~ 50Hz		
European energy label			Cooling	A	A	
			Heating	A	A	
Capacity	Cooling	Rated	kW	3.50	4.30	
		BTU/h	11950	14650		
		Min.-Max.	kW	0.90 - 4.40	0.90 - 5.40	
	BTU/h	3100 - 15000	3100 - 18400			
	Heating	Rated	kW	4.10	5.00	
		BTU/h	14000	17050		
Min.-Max.		kW	0.90 - 5.70	0.90 - 6.50		
BTU/h	3100 - 19400	3100 - 22100				
Input power	Cooling	Rated	kW	1.05	1.33	
		*Max.		1.73	2.07	
	Heating	Rated		1.11	1.34	
		*Max.		2.30	2.88	
Current	Cooling	Rated	A	4.6	5.8	
		*Max.		7.5	9.0	
	Heating	Rated		4.9	5.9	
		*Max.		10.0	12.5	
EER		Cooling	kW/kW	3.33	3.21	
COP		Heating		3.69	3.71	
Moisture removal			l/h (pints/h)	1.2 (2.1)	1.5 (2.6)	
Fan	Airflow rate	Cooling	High	m ³ /h	600	680
			Med		530	580
			Low		470	490
		Quiet	410		410	
		Heating	High		600	800
			Med		530	680
	Low		470	580		
	Quiet	410	450			
	Type × Q'ty			Turbo × 1		
	Motor output			W	54	
Sound pressure level	Cooling	High	dB(A)	37	38	
		Med		34	34	
		Low		30	30	
		Quiet		27	27	
	Heating	High		37	43	
		Med		34	38	
		Low		31	34	
		Quiet		29	30	
Heat exchanger type	Dimensions (H × W × D)		mm	210 × 1310 × 13.3	210 × 1310 × 13.3	
				210 × 1250 × 13.3	210 × 1250 × 13.3	
	Fin pitch		1.20	1.20		
	Rows x Stages		2X10	2X10		
	Pipe type		Copper tube			
Fin type		Aluminium				
Enclosure		Material	PS			
		Colour	WHITE Approximate colour of MUNSELL N 9.25/			
Dimensions (H×W×D)	Net	Unit	mm	245 × 570 × 570		
		Panel		49 × 700 × 700		
	Gross	Unit		265 × 730 × 625		
		Panel		120 × 765 × 755		
Weight	Net	Unit	kg(lb.)	15 (33)	15 (33)	
		Panel		2.6 (5.7)		
	Gross	Unit		18 (40)	18 (40)	
		Panel		4.5 (10.0)		
Connection pipe	Size	Liquid	mm	φ 6.35 (φ 1/4 in.)		
		Gas		φ 9.52(φ 3/8 in.)	φ 12.70(φ 1/2 in.)	
	Method	Flare				
Operation range	Cooling	°C	18 to 32			
		%RH	80 or less			
	Heating	°C	30 or less			
Remote controller type				WIRELESS		
Drain pipe	Material			ABS		
	Size	mm	Outer diameter : 25.4 / Inner diameter : 19.4			

Note :

Specifications are based on the following conditions.

Cooling : Indoor temperature of 27 °CDB / 19 °CWB and outdoor temperature of 35 °CDB/24 °CWB.

Heating : Indoor temperature of 20 °CDB / 15 °CWB and outdoor temperature of 7 °CDB/6 °CWB.

Pipe length : 7.5 m, Height difference : 0 m.(Outdoor unit - Indoor unit)

Ceiling mode : Standard

*The maximum current and the maximum input value are the maximum values when operated within the operation range (temperature).

Type				CASSETTE MODEL		
				INVERTER HEATPUMP		
Model name				AU * A12LAL, AU * F12LAL	AU * A14LAL, AU * F14LAL	
				AO * B12LAACL, AO * B12LALL	AO * B14LAACL, AO * B14LALL	
Power source				230V ~ 50Hz		
Available voltage range				198-264V ~ 50Hz		
European energy label			Cooling	B	B	
			Heating	B	B	
Capacity	Cooling	Rated	kW	3.50	4.30	
		Min.-Max.	BTU/h	11950	14650	
			kW	0.90 - 4.30	0.90 - 5.20	
	Heating	Rated	BTU/h	3100 - 14650	3100 - 17750	
			kW	4.10	5.00	
		Min.-Max.	BTU/h	14000	17050	
kW	0.90 - 5.50	0.90 - 6.30	BTU/h	3100 - 18750	3100 - 21500	
Input power	Cooling	Rated	kW	1.11	1.41	
		*Max.		1.73	2.07	
	Heating	Rated		1.17	1.42	
		*Max.		2.30	2.88	
Current	Cooling	Rated	A	4.9	6.2	
		*Max.		7.5	9.0	
	Heating	Rated		5.1	6.2	
		*Max.		10.0	12.5	
EER		Cooling	kW/kW		3.15	3.05
COP		Heating			3.50	3.52
Moisture removal			l/h (pints/h)	1.2 (2.1)	1.5 (2.6)	
Fan	Airflow rate	Cooling	High	m ³ /h	600	680
			Med		530	580
			Low		470	490
		Quiet	410		410	
		Heating	High		600	800
			Med		530	680
	Low		470	580		
				Quiet	410	450
	Type × Q'ty			Turbo × 1		
	Motor output			W		
Sound pressure level	Cooling	High	dB(A)	37	38	
		Med		34	34	
		Low		30	30	
		Quiet		27	27	
	Heating	High		37	43	
		Med		34	38	
		Low		31	34	
		Quiet		29	30	
Heat exchanger type	Dimensions (H × W × D)		mm	210 × 1310 × 13.3	210 × 1310 × 13.3	
				210 × 1250 × 13.3	210 × 1250 × 13.3	
	Fin pitch				1.20	1.20
	Rows x Stages				2X10	2X10
	Pipe type		Copper tube			
Fin type		Aluminium				
Enclosure		Material	PS			
		Colour	WHITE Approximate colour of MUNSELL N 9.25/			
Dimensions (H×W×D)	Net	Unit	mm	245 × 570 × 570		
		Panel		49 × 700 × 700		
	Gross	Unit		265 × 730 × 625		
		Panel		120 × 765 × 755		
Weight	Net	Unit	kg(lb.)	15 (33)	15 (33)	
		Panel		2.6 (5.7)		
	Gross	Unit		18 (40)	18 (40)	
		Panel		4.5 (10.0)		
Connection pipe	Size	Liquid	mm	φ6.35 (φ1/4 in.)		
		Gas		φ9.52(φ3/8 in.)	φ12.70(φ1/2 in.)	
	Method	Flare				
Operation range	Cooling	°C	18 to 32			
		%RH	80 or less			
	Heating	°C	30 or less			
Remote controller type				WIRELESS		
Drain pipe	Material			ABS		
	Size	mm		Outer diameter : 25.4 / Inner diameter : 19.4		

Note :

Specifications are based on the following conditions.

Cooling : Indoor temperature of 27 °CDB / 19 °CWB and outdoor temperature of 35 °CDB/24 °CWB.

Heating : Indoor temperature of 20 °CDB / 15 °CWB and outdoor temperature of 7 °CDB/6 °CWB.

Pipe length : 7.5 m, Height difference : 0 m.(Outdoor unit - Indoor unit)

Ceiling mode : Standard

*The maximum current and the maximum input value are the maximum values when operated within the operation range (temperature).

4. DIMENSIONS

■ MODEL : AU*A12L, AU*F12L, AU*A14L, AU*F14L

(Unit : mm)

• Decoration panel mounting state

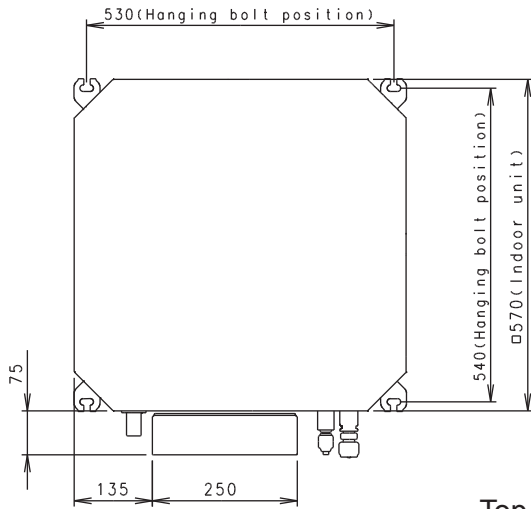

Top view

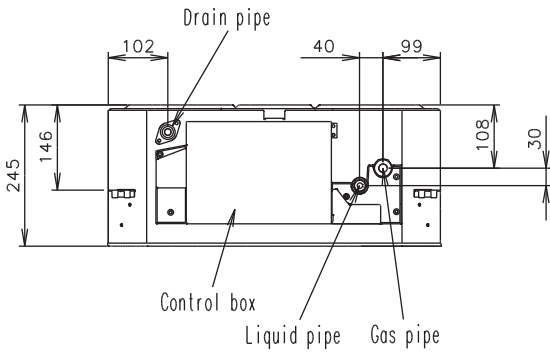
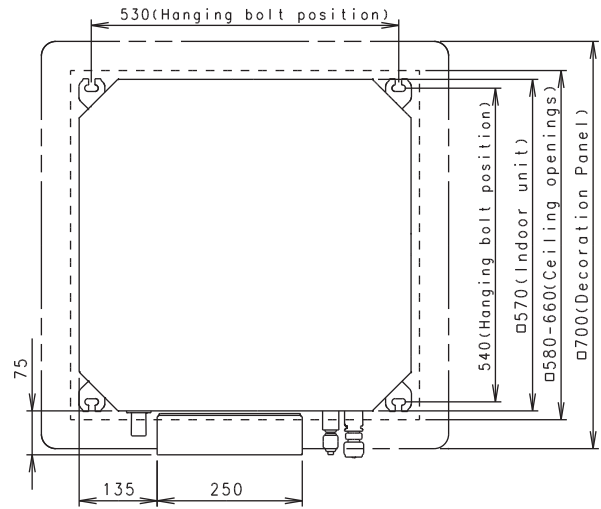

Side view

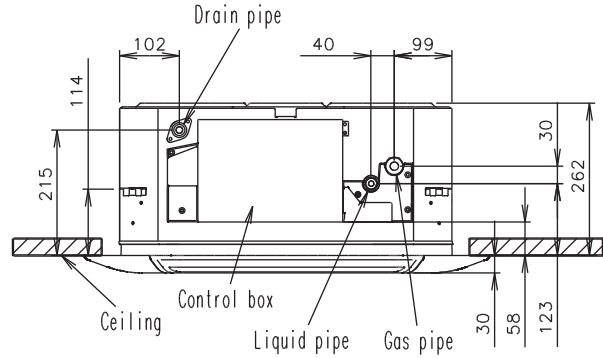

■ MODEL : UTG-UF*A-W, UTG-UF*B-W

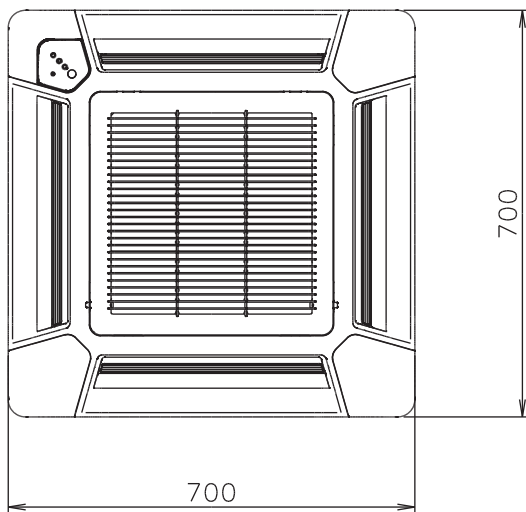

Bottom view (Panel)

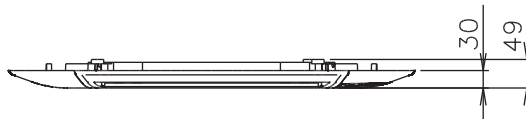

Side view

■ INSTALLATION PLACE

(Unit : mm)

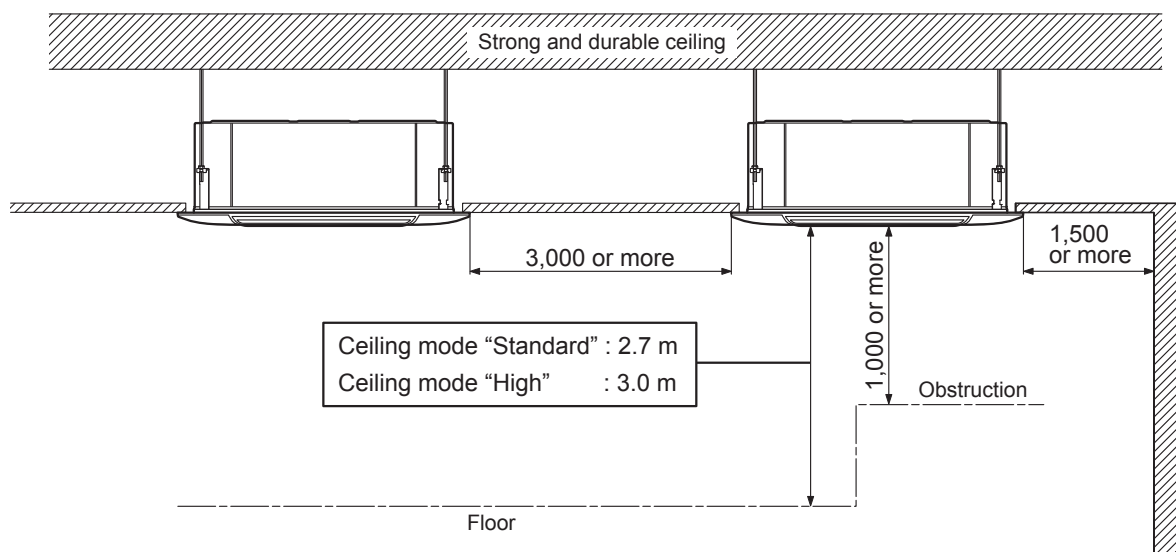

● 3-way directions setting

(Unit : mm)

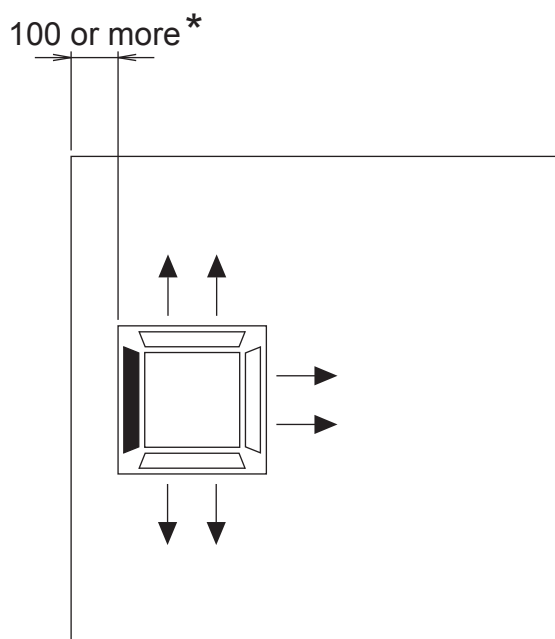

To set "3-way directions", the air outlet shutter plate(UTR-YDZA or UTR-YDZB) sold separately must be installed and "outlet-direction" switched to "3-way" by remote controller.

*When installing the indoor unit, be careful about the maintenance hole

5. WIRING DIAGRAMS

■ MODEL : AU*A12L, AU*F12L, AU*A14L, AU*F14L

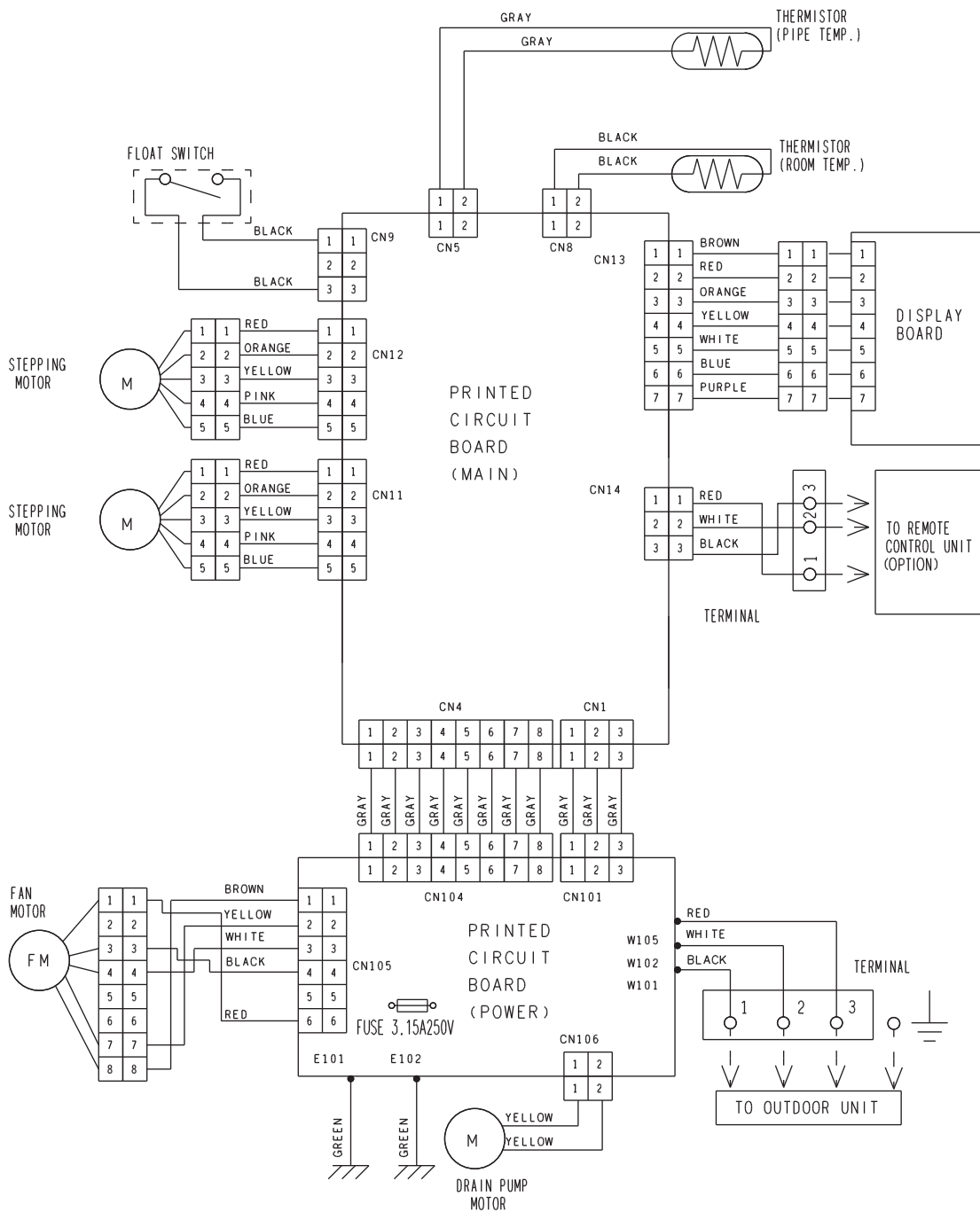

6. CAPACITY TABLE

6-1. COOLING CAPACITY

This table is created using the maximum capacity.

■ MODEL : AU*A12L, AU*F12L / AO*A12L

AFR	10.0
-----	------

	°CDB °CWB	Indoor temperature																				
		18			21			23			25			27			29			32		
		12			15			16			18			19			21			23		
Outdoor temperature	°CDB	TC	SHC	PI	TC	SHC	PI	TC	SHC	PI	TC	SHC	PI	TC	SHC	PI	TC	SHC	PI	TC	SHC	PI
	-10	3.47	3.22	0.29	3.87	3.24	0.30	4.00	3.52	0.30	4.26	3.53	0.30	4.40	3.81	0.30	4.66	3.80	0.31	4.92	4.05	0.31
	0	3.29	3.07	0.49	3.67	3.09	0.50	3.79	3.36	0.50	4.05	3.37	0.51	4.17	3.64	0.51	4.42	3.63	0.51	4.67	3.86	0.52
	5	3.30	3.07	0.47	3.67	3.09	0.48	3.80	3.36	0.48	4.05	3.37	0.49	4.17	3.64	0.49	4.42	3.63	0.50	4.67	3.86	0.50
	10	3.30	3.07	0.44	3.67	3.09	0.45	3.80	3.36	0.45	4.05	3.37	0.45	4.17	3.64	0.46	4.42	3.63	0.46	4.67	3.86	0.46
	15	3.19	2.99	0.53	3.56	3.01	0.54	3.68	3.27	0.54	3.92	3.28	0.55	4.04	3.54	0.55	4.28	3.53	0.56	4.53	3.76	0.56
	20	4.12	3.76	1.23	4.59	3.78	1.25	4.74	4.11	1.26	5.05	4.12	1.27	5.21	4.45	1.28	5.52	4.43	1.29	5.84	4.72	1.31
	25	3.95	3.62	1.37	4.40	3.64	1.40	4.55	3.96	1.40	4.85	3.97	1.42	5.00	4.29	1.42	5.30	4.27	1.44	5.60	4.55	1.45
	30	3.78	3.47	1.52	4.21	3.49	1.54	4.35	3.80	1.55	4.64	3.81	1.57	4.78	4.12	1.57	5.07	4.10	1.59	5.36	4.37	1.61
	35	3.48	3.22	1.54	3.87	3.24	1.56	4.00	3.52	1.57	4.27	3.54	1.59	4.40	3.82	1.60	4.66	3.80	1.61	4.93	4.05	1.63
40	2.96	2.80	1.31	3.29	2.81	1.33	3.40	3.06	1.34	3.63	3.07	1.35	3.74	3.31	1.36	3.97	3.30	1.37	4.19	3.51	1.39	
46	2.19	2.17	1.00	2.44	2.18	1.02	2.52	2.38	1.03	2.68	2.38	1.04	2.77	2.57	1.04	2.93	2.56	1.05	3.10	2.73	1.06	

■ MODEL : AU*A12L, AU*F12L / AO*B12L

AFR	10.0
-----	------

	°CDB °CWB	Indoor temperature																				
		18			21			23			25			27			29			32		
		12			15			16			18			19			21			23		
Outdoor temperature	°CDB	TC	SHC	PI	TC	SHC	PI	TC	SHC	PI	TC	SHC	PI	TC	SHC	PI	TC	SHC	PI	TC	SHC	PI
	-10	3.47	3.22	0.29	3.87	3.24	0.30	4.00	3.52	0.30	4.26	3.53	0.30	4.40	3.81	0.30	4.66	3.80	0.31	4.92	4.05	0.31
	0	3.29	3.07	0.49	3.67	3.09	0.50	3.79	3.36	0.50	4.05	3.37	0.51	4.17	3.64	0.51	4.42	3.63	0.51	4.67	3.86	0.52
	5	3.30	3.07	0.47	3.67	3.09	0.48	3.80	3.36	0.48	4.05	3.37	0.49	4.17	3.64	0.49	4.42	3.63	0.50	4.67	3.86	0.50
	10	3.30	3.07	0.44	3.67	3.09	0.45	3.80	3.36	0.45	4.05	3.37	0.45	4.17	3.64	0.46	4.42	3.63	0.46	4.67	3.86	0.46
	15	3.19	2.99	0.53	3.56	3.01	0.54	3.68	3.27	0.54	3.92	3.28	0.55	4.04	3.54	0.55	4.28	3.53	0.56	4.53	3.76	0.56
	20	4.12	3.76	1.23	4.59	3.78	1.25	4.74	4.11	1.26	5.05	4.12	1.27	5.21	4.45	1.28	5.52	4.43	1.29	5.84	4.72	1.31
	25	3.95	3.62	1.37	4.40	3.64	1.40	4.55	3.96	1.40	4.85	3.97	1.42	5.00	4.29	1.42	5.30	4.27	1.44	5.60	4.55	1.45
	30	3.78	3.47	1.52	4.21	3.49	1.54	4.35	3.80	1.55	4.64	3.81	1.57	4.78	4.12	1.57	5.07	4.10	1.59	5.36	4.37	1.61
	35	3.40	3.14	1.54	3.78	3.16	1.56	3.91	3.43	1.57	4.17	3.44	1.59	4.30	3.72	1.60	4.56	3.70	1.61	4.81	3.94	1.63
40	2.89	2.72	1.31	3.22	2.74	1.33	3.33	2.98	1.34	3.55	2.99	1.35	3.66	3.23	1.36	3.87	3.21	1.37	4.09	3.42	1.39	
46	2.14	2.12	1.00	2.38	2.13	1.02	2.46	2.32	1.03	2.62	2.32	1.04	2.70	2.51	1.04	2.87	2.50	1.05	3.03	2.66	1.06	

AFR : Air Flow Rate (m³/min)
 TC : Total Capacity (kW)
 SHC : Sensible Heat Capacity (kW)
 PI : Power Input (kW)

■ MODEL : AU*A14L, AU*F14L / AO*A14L

AFR	11.3
-----	------

		Indoor temperature																				
		18			21			23			25			27			29			32		
		12			15			16			18			19			21			23		
Outdoor temperature	°CDB	TC	SHC	PI	TC	SHC	PI	TC	SHC	PI	TC	SHC	PI	TC	SHC	PI	TC	SHC	PI	TC	SHC	PI
	-10	4.08	3.75	0.39	4.54	3.77	0.40	4.69	4.10	0.40	5.00	4.11	0.40	5.16	4.44	0.40	5.47	4.43	0.41	5.78	4.71	0.41
	0	3.98	3.68	0.45	4.44	3.70	0.46	4.59	4.02	0.46	4.89	4.03	0.47	5.04	4.35	0.47	5.34	4.34	0.48	5.65	4.62	0.48
	5	3.87	3.59	0.56	4.31	3.61	0.57	4.46	3.92	0.57	4.75	3.93	0.58	4.90	4.25	0.58	5.19	4.23	0.59	5.49	4.51	0.59
	10	3.74	3.48	0.66	4.17	3.50	0.67	4.31	3.81	0.68	4.60	3.82	0.68	4.74	4.13	0.69	5.02	4.11	0.70	5.31	4.38	0.70
	15	3.75	3.49	0.58	4.18	3.51	0.59	4.32	3.82	0.60	4.61	3.83	0.60	4.75	4.14	0.60	5.04	4.12	0.61	5.32	4.39	0.62
	20	4.72	4.27	1.23	5.26	4.30	1.25	5.44	4.67	1.25	5.79	4.69	1.27	5.97	5.06	1.27	6.33	5.04	1.29	6.69	5.37	1.30
	25	4.53	4.11	1.37	5.04	4.14	1.39	5.21	4.50	1.40	5.56	4.51	1.41	5.73	4.88	1.42	6.07	4.86	1.44	6.42	5.17	1.45
	30	4.32	3.95	1.52	4.81	3.97	1.54	4.98	4.32	1.55	5.30	4.33	1.56	5.47	4.68	1.57	5.80	4.66	1.59	6.12	4.96	1.60
	35	4.27	3.90	1.79	4.75	3.93	1.82	4.91	4.27	1.83	5.24	4.28	1.85	5.40	4.63	1.85	5.72	4.61	1.87	6.05	4.91	1.89
40	3.28	3.12	1.28	3.66	3.13	1.30	3.78	3.41	1.30	4.03	3.42	1.32	4.16	3.69	1.32	4.41	3.68	1.34	4.66	3.92	1.35	
46	2.36	2.39	0.97	2.63	2.40	0.98	2.72	2.61	0.99	2.90	2.62	1.00	2.99	2.83	1.00	3.17	2.82	1.01	3.35	3.00	1.02	

■ MODEL : AU*A14L, AU*F14L / AO*B14L

AFR	11.3
-----	------

		Indoor temperature																				
		18			21			23			25			27			29			32		
		12			15			16			18			19			21			23		
Outdoor temperature	°CDB	TC	SHC	PI	TC	SHC	PI	TC	SHC	PI	TC	SHC	PI	TC	SHC	PI	TC	SHC	PI	TC	SHC	PI
	-10	4.08	3.75	0.39	4.54	3.77	0.40	4.69	4.10	0.40	5.00	4.11	0.40	5.16	4.44	0.40	5.47	4.43	0.41	5.78	4.71	0.41
	0	3.98	3.68	0.45	4.44	3.70	0.46	4.59	4.02	0.46	4.89	4.03	0.47	5.04	4.35	0.47	5.34	4.34	0.48	5.65	4.62	0.48
	5	3.87	3.59	0.56	4.31	3.61	0.57	4.46	3.92	0.57	4.75	3.93	0.58	4.90	4.25	0.58	5.19	4.23	0.59	5.49	4.51	0.59
	10	3.74	3.48	0.66	4.17	3.50	0.67	4.31	3.81	0.68	4.60	3.82	0.68	4.74	4.13	0.69	5.02	4.11	0.70	5.31	4.38	0.70
	15	3.75	3.49	0.58	4.18	3.51	0.59	4.32	3.82	0.60	4.61	3.83	0.60	4.75	4.14	0.60	5.04	4.12	0.61	5.32	4.39	0.62
	20	4.72	4.27	1.23	5.26	4.30	1.25	5.44	4.67	1.25	5.79	4.69	1.27	5.97	5.06	1.27	6.33	5.04	1.29	6.69	5.37	1.30
	25	4.53	4.11	1.37	5.04	4.14	1.39	5.21	4.50	1.40	5.56	4.51	1.41	5.73	4.88	1.42	6.07	4.86	1.44	6.42	5.17	1.45
	30	4.32	3.95	1.52	4.81	3.97	1.54	4.98	4.32	1.55	5.30	4.33	1.56	5.47	4.68	1.57	5.80	4.66	1.59	6.12	4.96	1.60
	35	4.11	3.74	1.79	4.58	3.76	1.82	4.73	4.09	1.83	5.04	4.10	1.85	5.20	4.43	1.85	5.51	4.41	1.87	5.82	4.70	1.89
40	3.16	2.99	1.28	3.52	3.00	1.30	3.64	3.27	1.30	3.88	3.28	1.32	4.00	3.54	1.32	4.24	3.52	1.34	4.48	3.75	1.35	
46	2.27	2.30	0.97	2.53	2.31	0.98	2.62	2.51	0.99	2.79	2.52	1.00	2.88	2.72	1.00	3.05	2.71	1.01	3.22	2.89	1.02	

AFR : Air Flow Rate (m³/min)
 TC : Total Capacity (kW)
 SHC : Sensible Heat Capacity (kW)
 PI : Power Input (kW)

6-2. HEATING CAPACITY

This table is created using the maximum capacity.

■ MODEL : AU*A12L, AU*F12L / AO*A12L

AFR	10.0
-----	------

		Indoor temperature										
		°CDB	16		18		20		22		24	
Outdoor temperature	°CDB	°CWB	TC	PI	TC	PI	TC	PI	TC	PI	TC	PI
	-15	-16	3.76	1.87	3.67	1.91	3.58	1.95	3.49	1.99	3.40	2.03
	-10	-11	4.26	1.87	4.16	1.91	4.06	1.95	3.96	1.99	3.86	2.03
	-5	-7	4.69	2.15	4.58	2.19	4.47	2.23	4.35	2.28	4.20	2.30
	0	-2	5.30	2.14	5.17	2.18	5.05	2.23	4.92	2.27	4.76	2.30
	5	3	5.79	2.15	5.65	2.19	5.51	2.24	5.38	2.28	5.18	2.30
	7	6	5.99	2.07	5.85	2.11	5.70	2.15	5.56	2.20	5.42	2.24
	10	8	6.05	1.84	5.91	1.87	5.76	1.91	5.62	1.95	5.47	1.99
	15	10	6.08	1.76	5.93	1.80	5.79	1.84	5.64	1.87	5.50	1.91
	20	15	5.87	1.48	5.73	1.51	5.59	1.54	5.45	1.57	5.31	1.61
24	18	5.86	1.48	5.72	1.51	5.58	1.54	5.44	1.57	5.30	1.60	

■ MODEL : AU*A12L, AU*F12L / AO*B12L

AFR	10.0
-----	------

		Indoor temperature										
		°CDB	16		18		20		22		24	
Outdoor temperature	°CDB	°CWB	TC	PI	TC	PI	TC	PI	TC	PI	TC	PI
	-15	-16	3.76	1.87	3.67	1.91	3.58	1.95	3.49	1.99	3.40	2.03
	-10	-11	4.26	1.87	4.16	1.91	4.06	1.95	3.96	1.99	3.86	2.03
	-5	-7	4.53	2.15	4.42	2.19	4.31	2.23	4.20	2.28	4.20	2.30
	0	-2	5.12	2.14	4.99	2.18	4.87	2.23	4.75	2.27	4.76	2.30
	5	3	5.59	2.15	5.45	2.19	5.32	2.24	5.19	2.28	5.18	2.30
	7	6	5.78	2.07	5.64	2.11	5.50	2.15	5.37	2.20	5.23	2.24
	10	8	5.84	1.84	5.70	1.87	5.56	1.91	5.42	1.95	5.28	1.99
	15	10	5.87	1.76	5.73	1.80	5.59	1.84	5.45	1.87	5.31	1.91
	20	15	5.67	1.48	5.53	1.51	5.40	1.54	5.26	1.57	5.13	1.61
24	18	5.65	1.48	5.52	1.51	5.38	1.54	5.25	1.57	5.11	1.60	

AFR : Air Flow Rate (m³/min)

TC : Total Capacity (kW)

PI : Power Input (kW)

■ MODEL : AU*A14L, AU*F14L / AO*A14L

AFR	14.7
-----	------

		Indoor temperature										
		°CDB	16		18		20		22		24	
		°CDB	°CWB	TC	PI	TC	PI	TC	PI	TC	PI	TC
Outdoor temperature	-15	-16	4.24	2.16	4.14	2.21	4.04	2.25	3.94	2.30	3.84	2.34
	-10	-11	4.88	2.16	4.76	2.21	4.65	2.25	4.53	2.30	4.41	2.34
	-5	-7	5.49	2.40	5.36	2.45	5.23	2.50	5.10	2.55	4.97	2.60
	0	-2	6.37	2.73	6.22	2.79	6.07	2.84	5.87	2.88	5.61	2.88
	5	3	6.97	2.71	6.80	2.77	6.64	2.83	6.47	2.88	6.18	2.88
	7	6	6.82	2.36	6.66	2.40	6.50	2.45	6.34	2.50	6.17	2.55
	10	8	7.03	2.37	6.86	2.42	6.70	2.47	6.53	2.52	6.36	2.56
	15	10	6.75	2.07	6.59	2.12	6.43	2.16	6.27	2.20	6.11	2.25
	20	15	6.22	1.59	6.07	1.63	5.92	1.66	5.77	1.69	5.62	1.73
	24	18	6.40	1.60	6.25	1.64	6.10	1.67	5.94	1.70	5.79	1.74

■ MODEL : AU*A14L, AU*F14L / AO*B14L

AFR	14.7
-----	------

		Indoor temperature										
		°CDB	16		18		20		22		24	
		°CDB	°CWB	TC	PI	TC	PI	TC	PI	TC	PI	TC
Outdoor temperature	-15	-16	4.24	2.16	4.14	2.21	4.04	2.25	3.94	2.30	3.84	2.34
	-10	-11	4.88	2.16	4.76	2.21	4.65	2.25	4.53	2.30	4.41	2.34
	-5	-7	5.49	2.40	5.36	2.45	5.23	2.50	5.10	2.55	4.97	2.60
	0	-2	6.37	2.73	6.22	2.79	6.07	2.84	5.87	2.88	5.61	2.88
	5	3	6.75	2.71	6.59	2.77	6.43	2.83	6.27	2.88	6.18	2.88
	7	6	6.61	2.36	6.45	2.40	6.30	2.45	6.14	2.50	5.98	2.55
	10	8	6.81	2.37	6.65	2.42	6.49	2.47	6.33	2.52	6.17	2.56
	15	10	6.54	2.07	6.39	2.12	6.23	2.16	6.07	2.20	5.92	2.25
	20	15	6.02	1.59	5.88	1.63	5.74	1.66	5.59	1.69	5.45	1.73
	24	18	6.20	1.60	6.05	1.64	5.91	1.67	5.76	1.70	5.61	1.74

AFR : Air Flow Rate (m³/min)
 TC : Total Capacity (kW)
 PI : Power Input (kW)

7. FAN PERFORMANCE

7-1. AIR VELOCITY DISTRIBUTION

■ MODEL : AU*A12L, AU*F12L

● 4-WAY AIR OUTLET

Unit : m/s

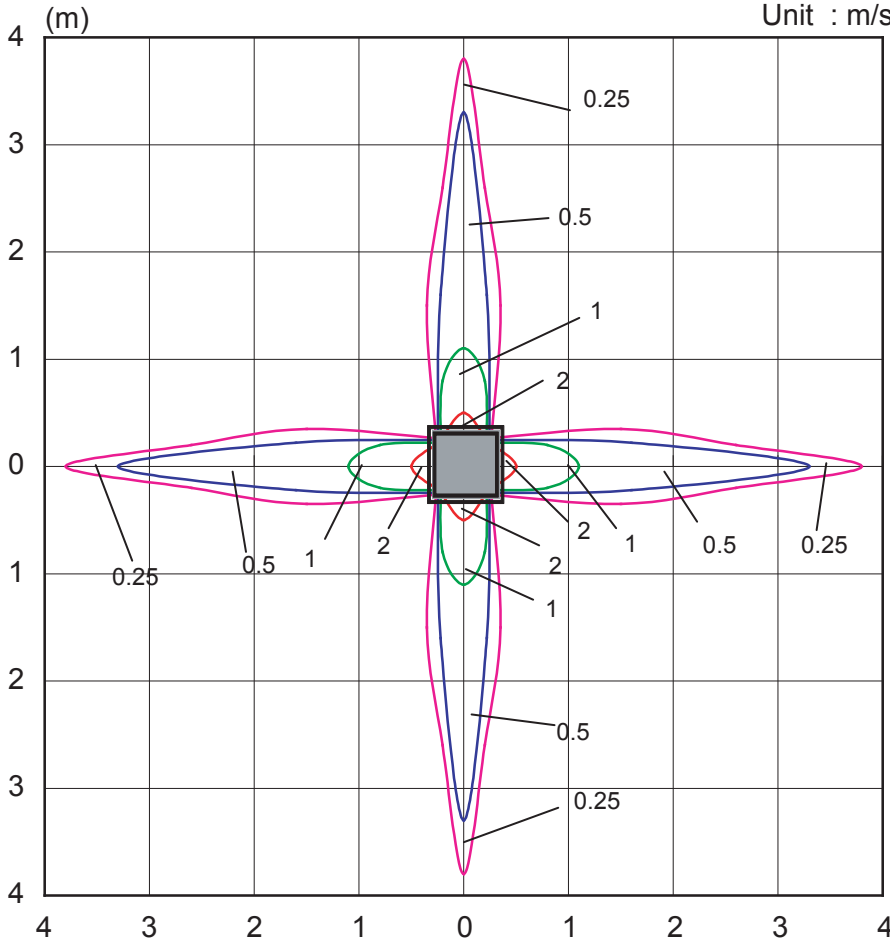

Note :
Condition
Fan speed : High
Operation mode : FAN
Ceiling mode : Standard

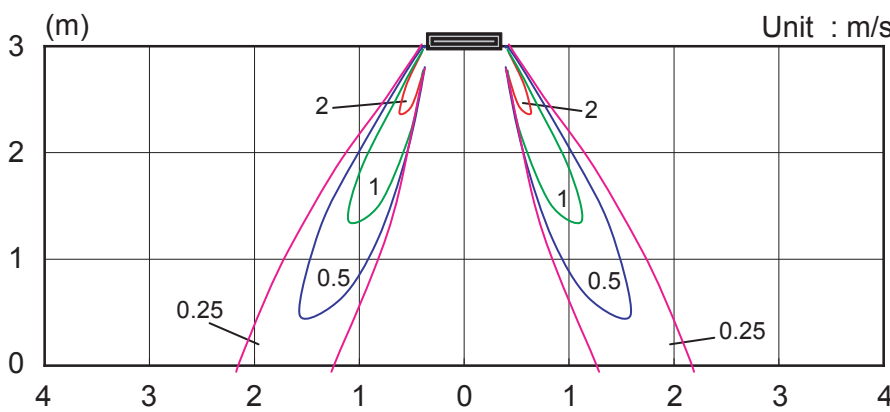
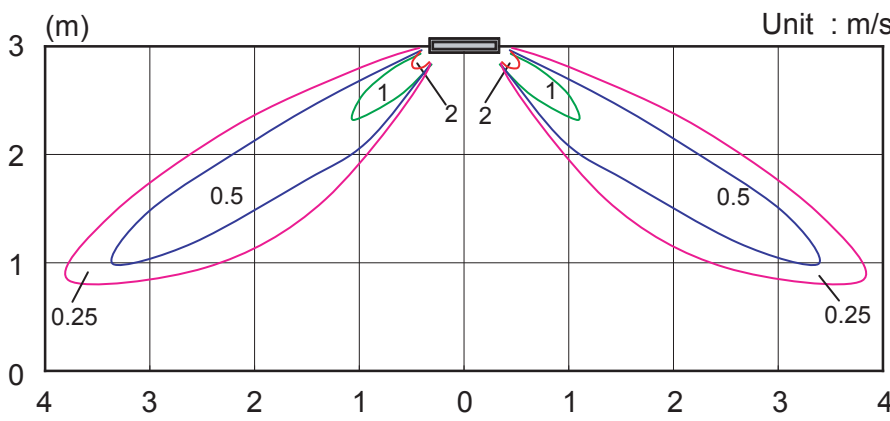

● 3-WAY AIR OUTLET

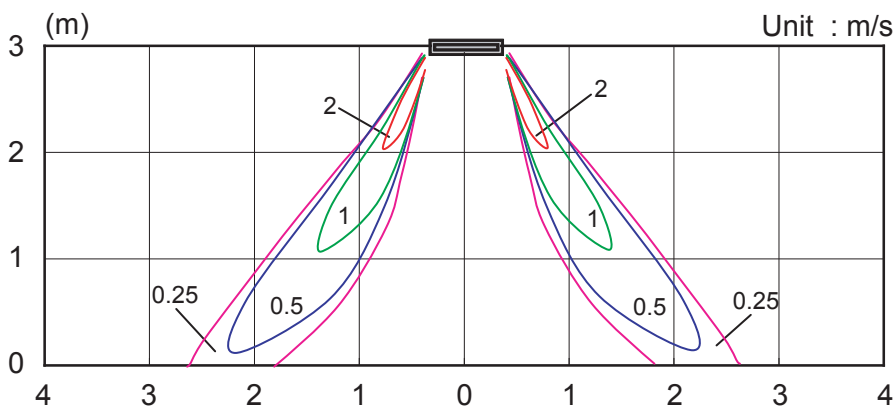
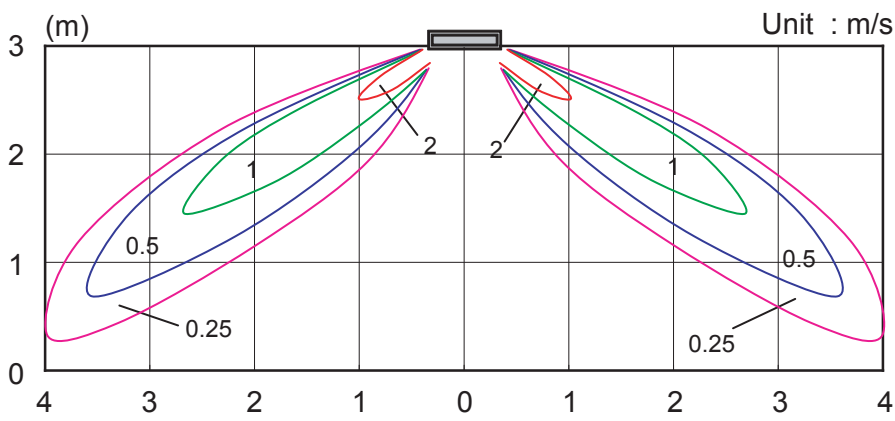
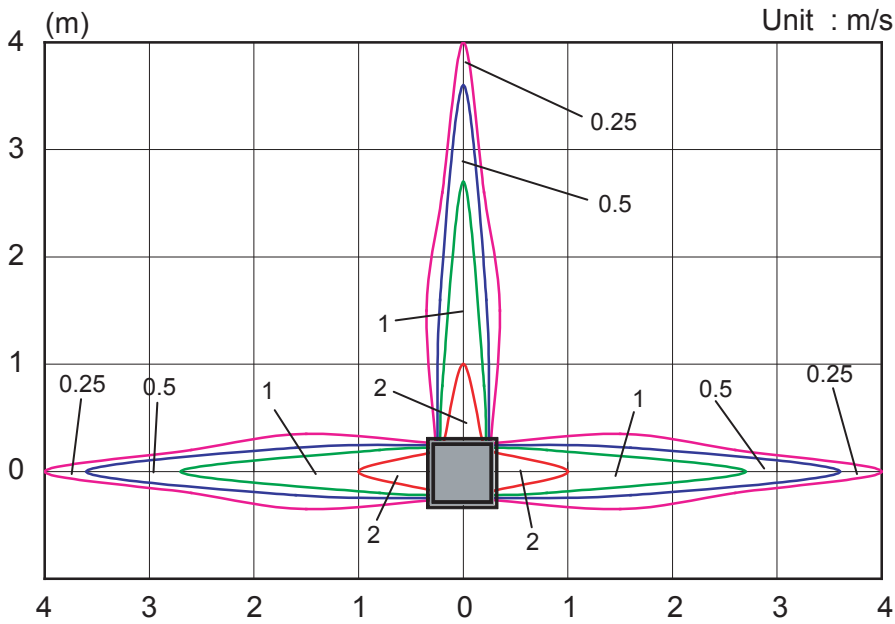

MODEL : AU*A14L, AU*F14L

4-WAY AIR OUTLET

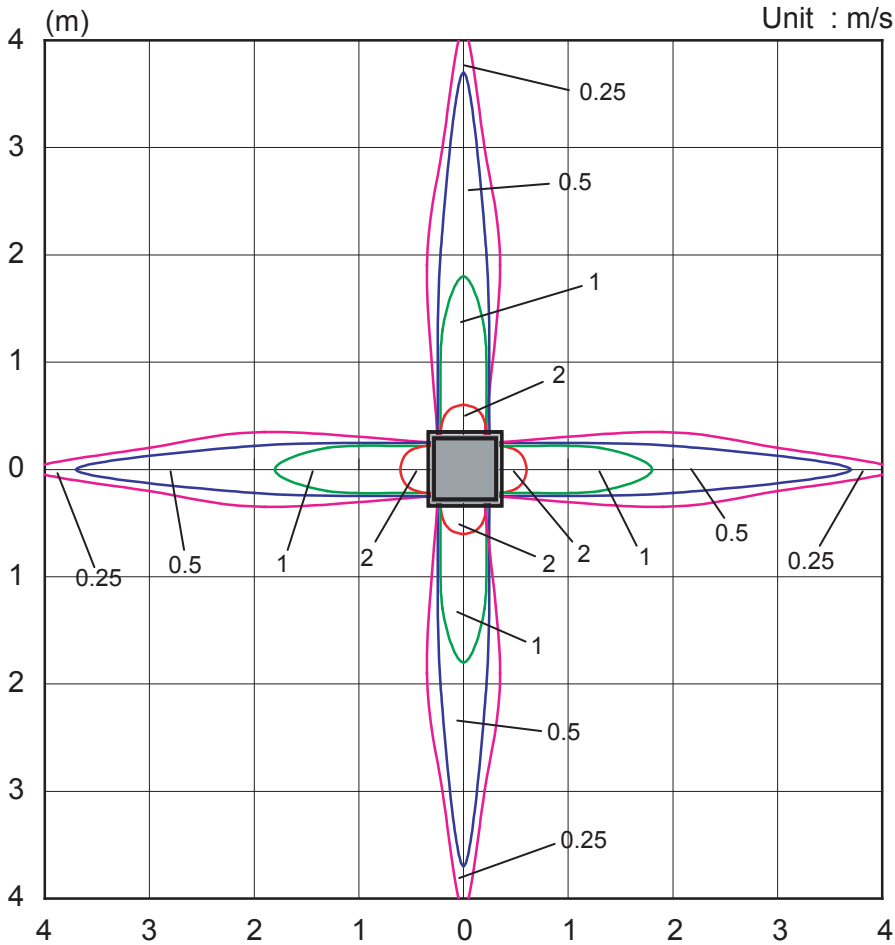

Note :
Condition
Fan speed : High
Operation mode : FAN
Ceiling mode : Standard

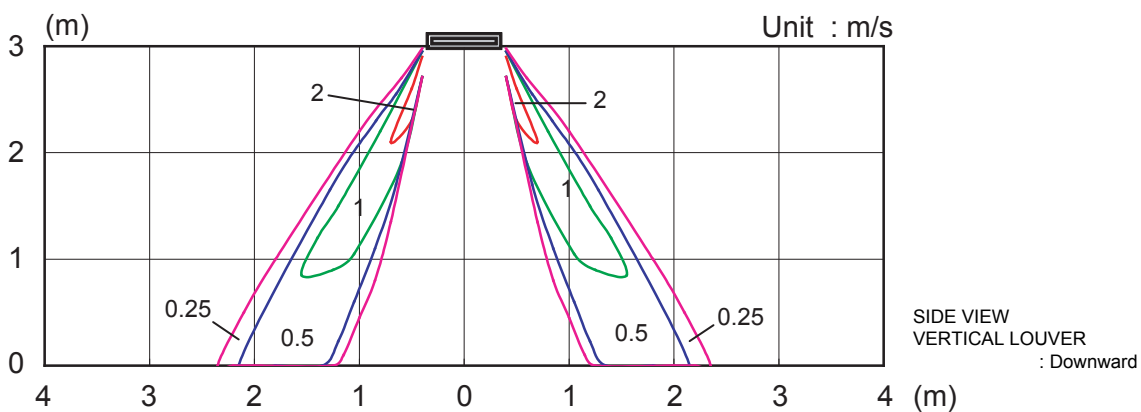
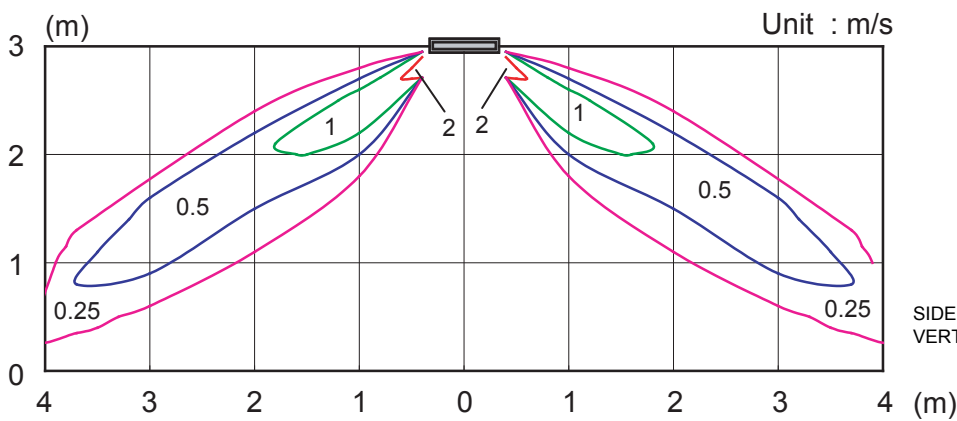

● 3-WAY AIR OUTLET

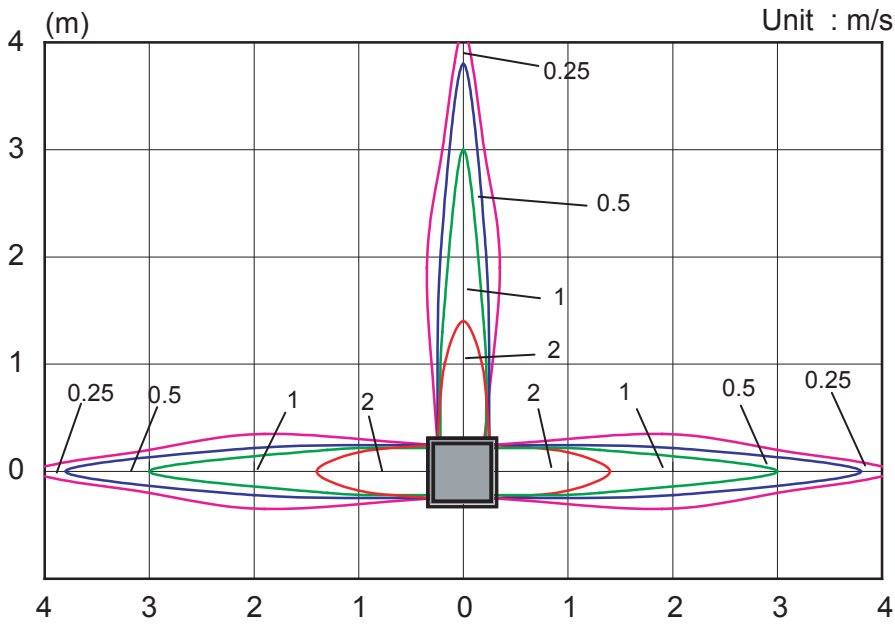

Note :
Condition
Fan speed : High
Operation mode : FAN
Ceiling mode : Standard

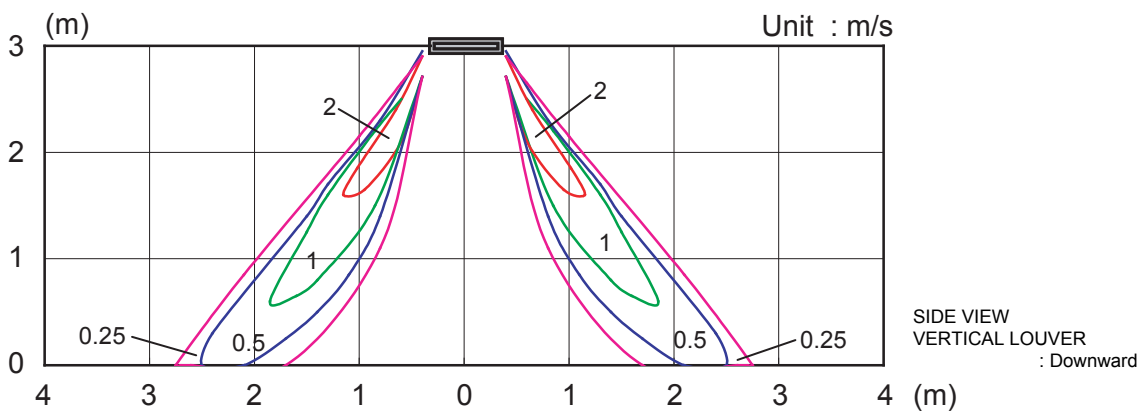
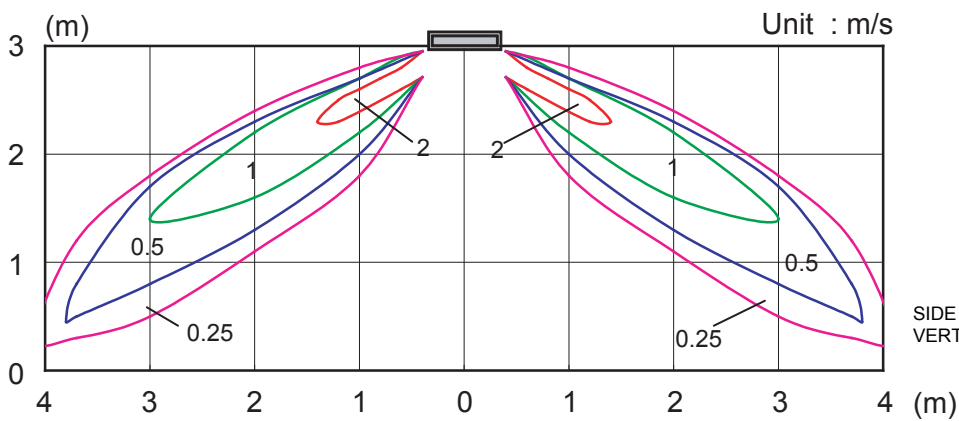

7-2. AIR FLOW

7-2-1. STANDARD CEILING MODE

■ MODEL : AU*A12L, AU*F12L

● COOLING

Fan speed	Number of rotations (r.p.m)	Air flow	
		m ³ /h	l/s
HIGH	650	m ³ /h	600
		l/s	167
		CFM	353
MED	580	m ³ /h	530
		l/s	147
		CFM	312
LOW	520	m ³ /h	470
		l/s	131
		CFM	277
QUIET	460	m ³ /h	410
		l/s	114
		CFM	241

● HEATING

Fan speed	Number of rotations (r.p.m)	Air flow	
		m ³ /h	l/s
HIGH	650	m ³ /h	600
		l/s	167
		CFM	353
MED	580	m ³ /h	530
		l/s	147
		CFM	312
LOW	520	m ³ /h	470
		l/s	131
		CFM	277
QUIET	460	m ³ /h	410
		l/s	114
		CFM	241

■ MODEL : AU*A14L, AU*F14L

● COOLING

Fan speed	Number of rotations (r.p.m)	Air flow	
		m ³ /h	l/s
HIGH	730	m ³ /h	680
		l/s	189
		CFM	400
MED	630	m ³ /h	580
		l/s	161
		CFM	341
LOW	540	m ³ /h	490
		l/s	136
		CFM	288
QUIET	460	m ³ /h	410
		l/s	114
		CFM	241

● HEATING

Fan speed	Number of rotations (r.p.m)	Air flow	
		m ³ /h	l/s
HIGH	830	m ³ /h	800
		l/s	222
		CFM	471
MED	730	m ³ /h	680
		l/s	189
		CFM	400
LOW	630	m ³ /h	580
		l/s	161
		CFM	341
QUIET	500	m ³ /h	450
		l/s	125
		CFM	265

7-2-2. HIGH CEILING MODE

■ MODEL : AU*A12L, AU*F12L

● COOLING

Fan speed	Number of rotations (r.p.m)	Air flow	
		m ³ /h	l/s
HIGH	750	m ³ /h	700
		l/s	194
		CFM	412
MED	680	m ³ /h	630
		l/s	175
		CFM	371
LOW	620	m ³ /h	570
		l/s	158
		CFM	335
QUIET	460	m ³ /h	410
		l/s	114
		CFM	241

● HEATING

Fan speed	Number of rotations (r.p.m)	Air flow	
		m ³ /h	l/s
HIGH	750	m ³ /h	700
		l/s	194
		CFM	412
MED	680	m ³ /h	630
		l/s	175
		CFM	371
LOW	620	m ³ /h	570
		l/s	158
		CFM	335
QUIET	460	m ³ /h	410
		l/s	114
		CFM	241

■ MODEL : AU*A14L, AU*F14L

● COOLING

Fan speed	Number of rotations (r.p.m)	Air flow	
		m ³ /h	l/s
HIGH	830	m ³ /h	800
		l/s	222
		CFM	471
MED	730	m ³ /h	680
		l/s	189
		CFM	400
LOW	640	m ³ /h	590
		l/s	164
		CFM	347
QUIET	460	m ³ /h	410
		l/s	114
		CFM	241

● HEATING

Fan speed	Number of rotations (r.p.m)	Air flow	
		m ³ /h	l/s
HIGH	930	m ³ /h	900
		l/s	250
		CFM	530
MED	830	m ³ /h	800
		l/s	222
		CFM	471
LOW	730	m ³ /h	680
		l/s	189
		CFM	400
QUIET	500	m ³ /h	450
		l/s	125
		CFM	265

8. OPERATION NOISE

8-1. NOISE LEVEL CURVE

■ MODEL : AU*A12L, AU*F12L

● COOLING

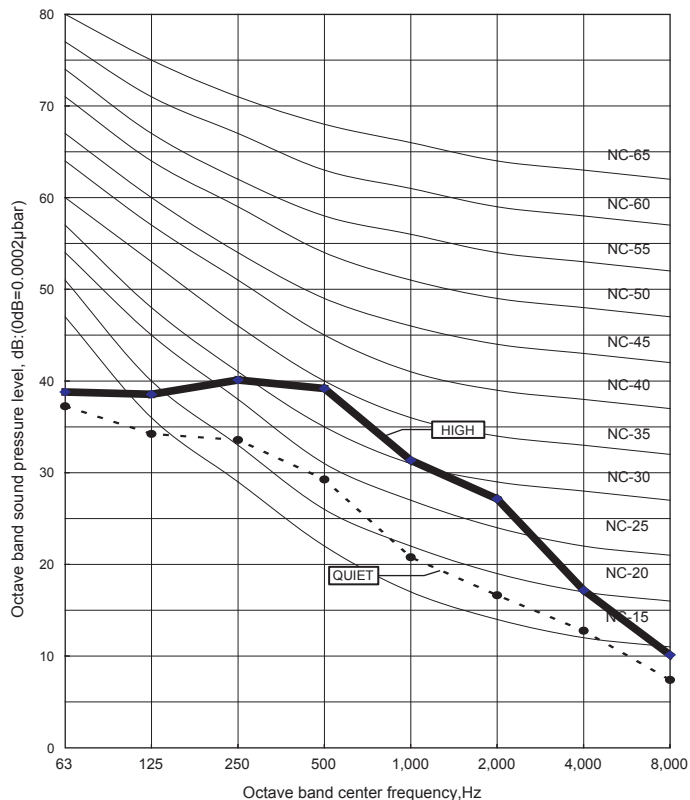

● HEATING

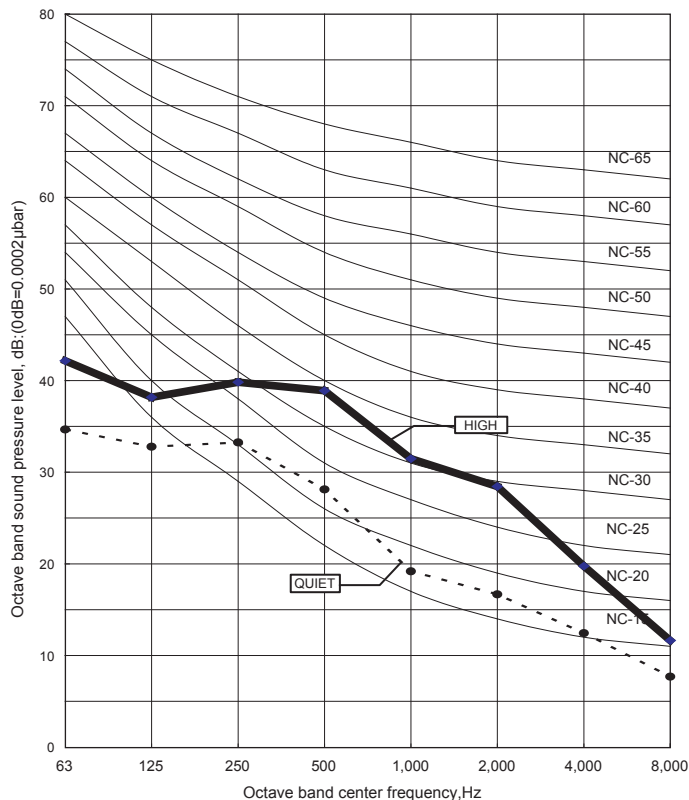

■ MODEL : AU*A14L, AU*F14L

● COOLING

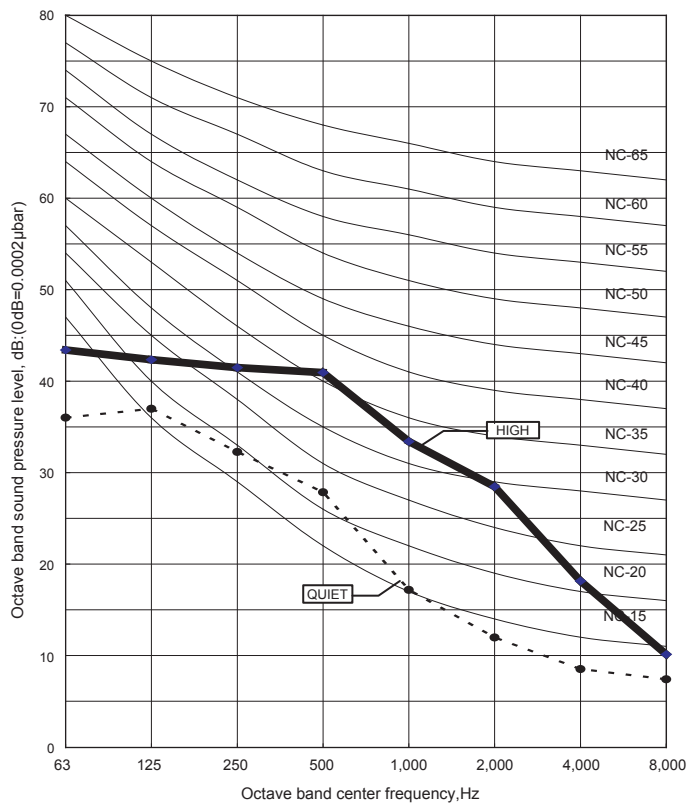

● HEATING

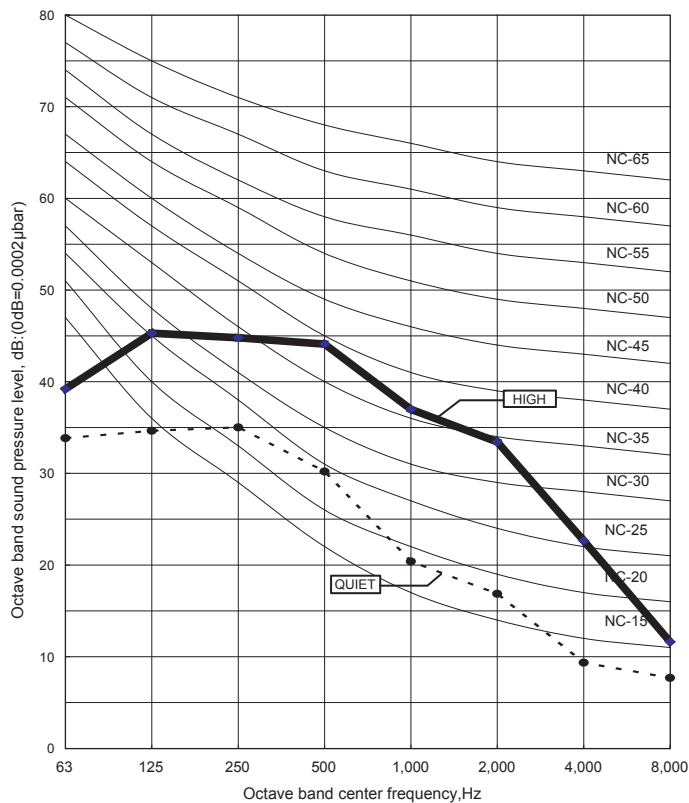

8-2. SOUND LEVEL CHECK POINT

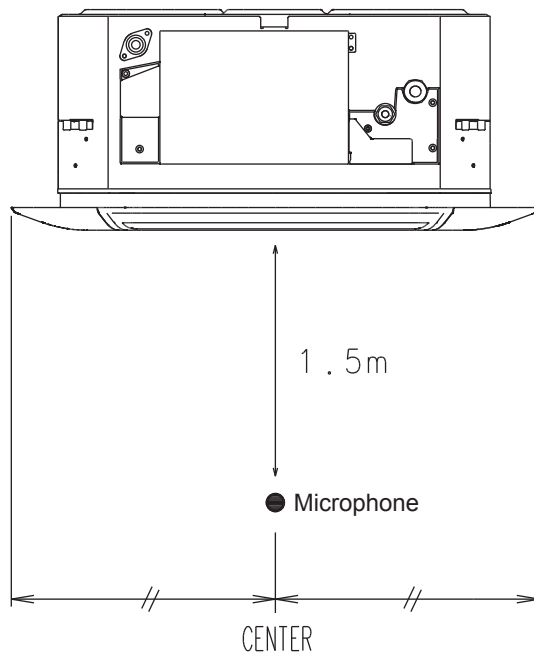
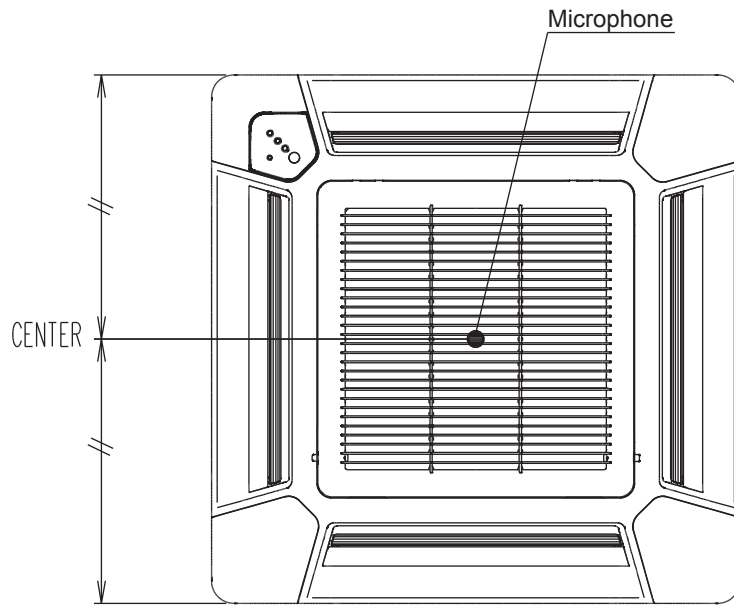

9. ELECTRIC CHARACTERISTICS

Model name			AU * A12L AU * F12L	AU * A14L AU * F14L
Power supply	Voltage	V	230 ~	
	Frequency	Hz	50	
Max. operating current (Indoor unit)		A	0.2	0.3
Wiring spec. (Indoor unit to outdoor unit)	Connection cable	mm ²	1.5-2.5	1.5-2.5
	Limited wiring length	m	26	26

10. SAFETY DEVICES

	Protection form	Model	
		AU * A12L AU * F12L	AU * A14L AU * F14L
Circuit protection	Current fuse (PCB)	3.15A 250V	
Fan motor protection	Thermal protection program	140±20°C OFF 110±20°C ON	

11. OPTIONAL PARTS

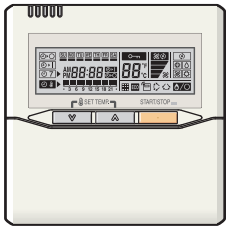
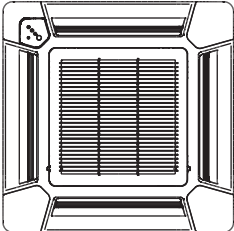
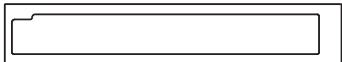
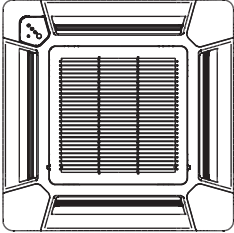
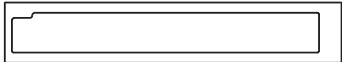
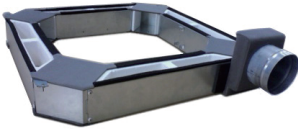
Exterior	Parts name	Model No.	Summary
	Wired remote controller	UTB-*UD	Unit control is performed by wired remote controller
	Decoration panel	UTG-UF*A-F	For AU*A12L, AU*A14L Ceiling dirt by discharged wind was made difficult to cling by reviewing the shape of the LOUVER.
	Air outlet shutter plate	UTR-YDZA	For AU*A12L, AU*A14L Air outlet shutter plate is installed at the air outlet when 3-way direction is performed.
	Decoration panel	UTG-UF*B-F	For AU*F12L, AU*F14L Ceiling dirt by discharged wind was made difficult to cling by reviewing the shape of the LOUVER.
	Air outlet shutter plate	UTR-YDZB	For AU*F12L, AU*F14L Air outlet shutter plate is installed at the air outlet when 3-way direction is performed.
	Fresh air intake kit	UTZ-VXAA	It can be taken in fresh air of up to 10% of "high" air volume of the indoor unit by attaching Fresh Air Intake Kit to cassette type indoor unit.

OUTDOOR UNIT

2. SINGLE TYPE :

AO * A12LACL

AO * A12LALL

AO * A14LACL

AO * A14LALL

1. SPECIFICATIONS

Type			INVERTER HEATPUMP	
Model name			AO * A12LACL AO * A12LALL	AO * A14LACL AO * A14LALL
Power source			230V~ 50Hz	
Available voltage range			198-264V~ 50Hz	
Starting current		A	4.9	5.9
Fan	Airflow rate	Cooling	1780	1910
		Heating	1630	1740
	Type × Q'ty		Propeller × 1	
	Motor output		W	54
Sound pressure level		Cooling	47	49
		Heating	48	49
Heat exchanger type		Dimensions (H × W × D)	546 × 876 × 18.2 546 × 842 × 18.2	
		Fin pitch	1.30	
		Rows x Stages	2 × 26	
		Pipe type	Copper	
		Fin type	Aluminium	
Compressor	Type × Q'ty		Twin Rotary × 1	
	Motor output		W	1100
Refrigerant		Type	R410A	
		Charge	g	1150
Refrigerant oil		Type	POE	
Enclosure		Material	Steel sheet	
		Colour	Beige (10YR7.5/1.0NN)	
Dimensions (H × W × D)	Net		578 × 790 × 300	
	Gross		648 × 910 × 380	
Weight	Net		40 (88)	40 (88)
	Gross		44 (97)	44 (97)
Connection pipe	Size	Liquid	Φ 6.35 (Φ 1/4 in.)	
		Gas	Φ 9.52 (Φ 3/8 in.)	Φ 12.70 (Φ 1/2 in.)
	Method		Flare	
	Max. length		25 (chargeless : 15)	
	Max. height difference		m	15
Operation range		Cooling	-10 to 46	
		Heating	-15 to 24	

Note :

Specifications are based on the following conditions.

Cooling : Indoor temperature of 27°CDB/19°CWB. and outdoor temperature of 35°CDB/24°CWB.

Heating : Indoor temperature of 20°CDB/15°CWB. and outdoor temperature of 7°CDB/6°CWB.

Pipe length : 7.5 m, Height difference : 0 m. (Outdoor unit - Indoor unit)

2. DIMENSIONS

■ MODEL : AO*A12L, AO*A14L

(Unit : mm)

OUTDOOR UNIT
AO*A12-14L

OUTDOOR UNIT
AO*A12-14L

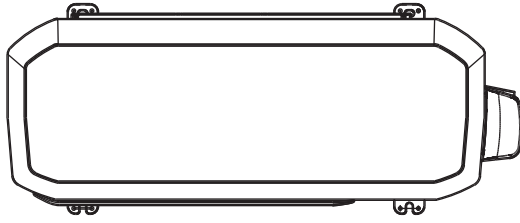

Top view

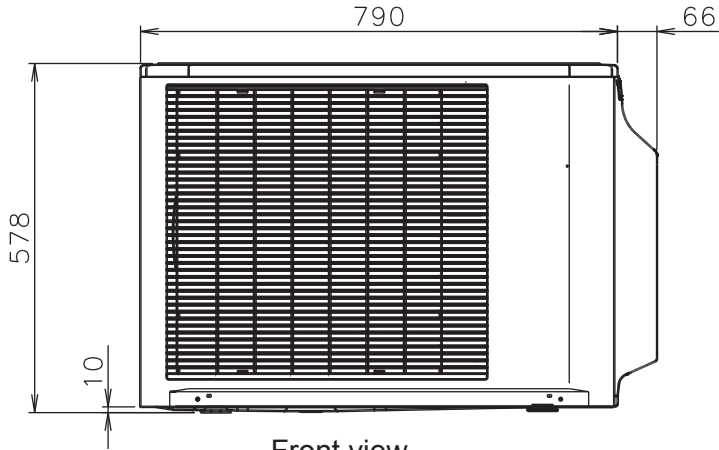

Front view

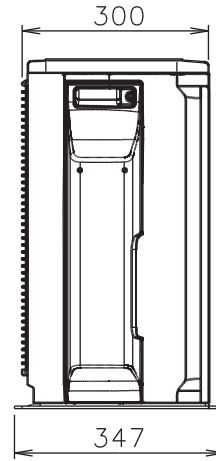

Side view

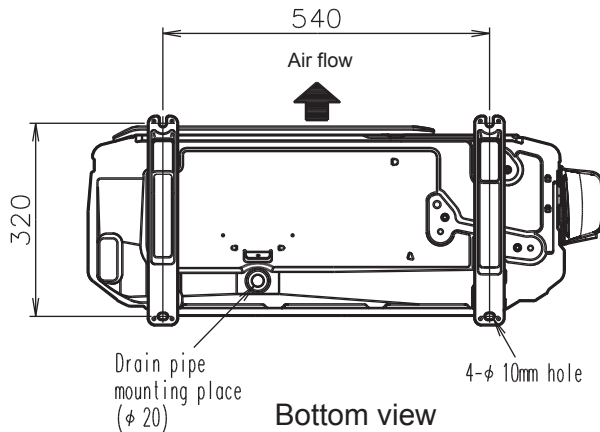

Bottom view

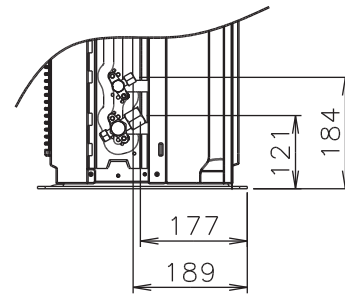

■ MOUNTING POSITION

When there are obstacles at the back or front sides.

When there are obstacles at the back, side(s), and top.

When there are obstacles at the back, side with the installation of more than one unit.

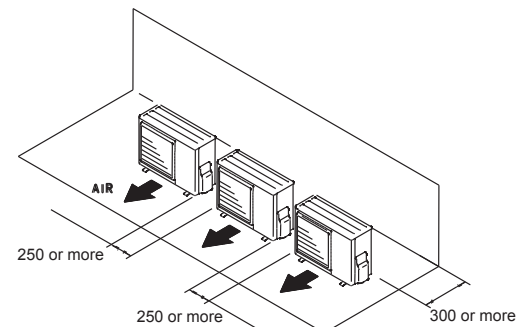
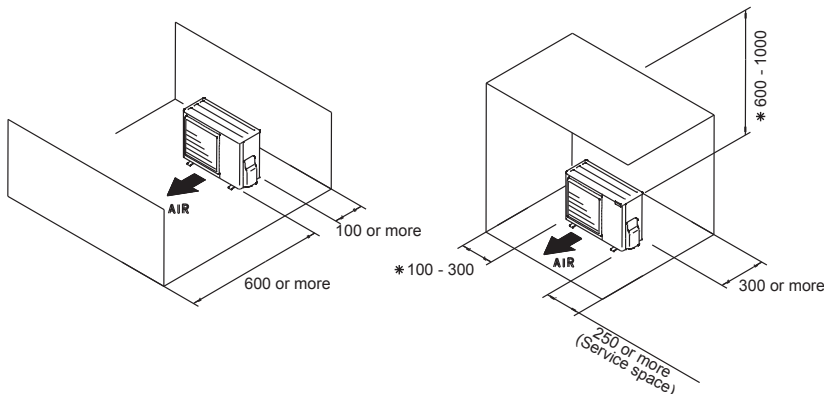

* If the space is larger than that is stated, the condition will be the same as that are no obstacles.

3. REFRIGERANT CIRCUIT

■ MODEL : AO*A12L, AO*A14L

OUTDOOR UNIT
AO*A12-14L

OUTDOOR UNIT
AO*A12-14L

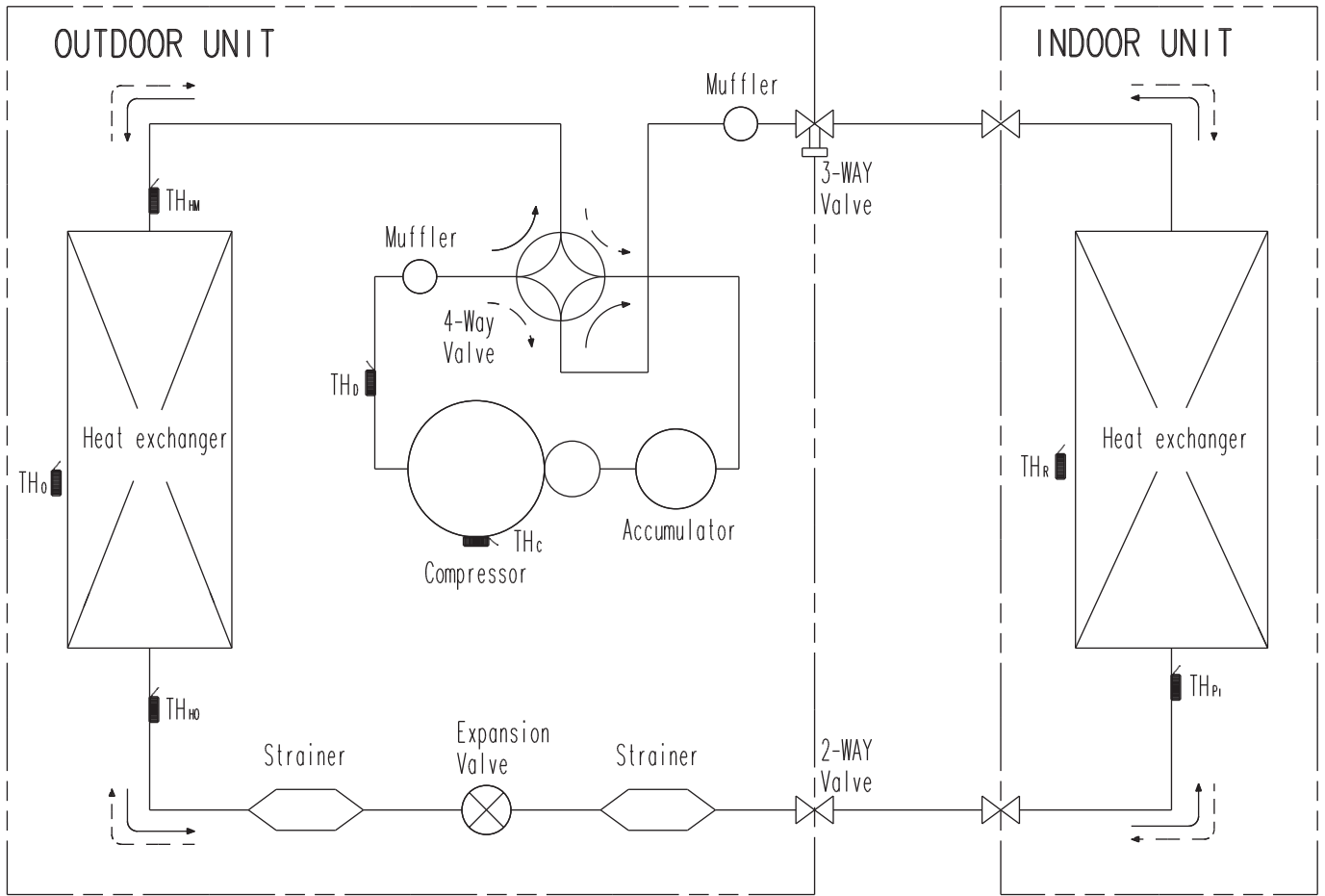

4. WIRING DIAGRAMS

■ MODEL : AO*A12L, AO*A14L

OUTDOOR UNIT
AO*A12-14L

OUTDOOR UNIT
AO*A12-14L

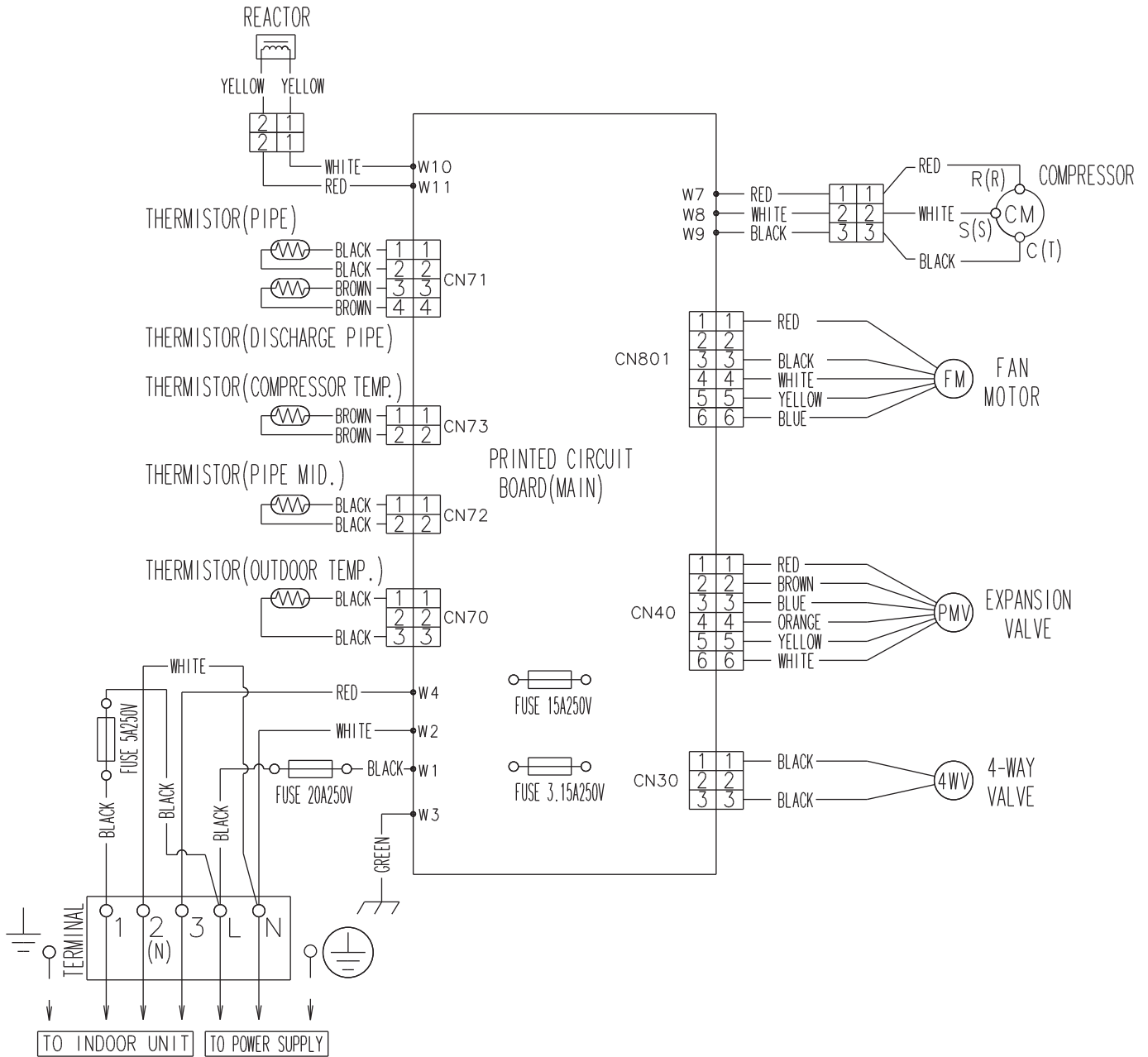

5. CAPACITY COMPENSATION RATE FOR PIPE LENGTH AND HEIGHT DIFFERENCE

This table is created using the maximum capacity.

■ MODEL : AO *A12L

OUTDOOR UNIT
AO*A12-14L

OUTDOOR UNIT
AO*A12-14L

COOLING			Pipe length (m)					
			5	7.5	10	15	20	25
Height difference H (m)	* 1 Indoor unit is upper than outdoor unit.	15	-	-	-	0.903	0.894	0.867
		10	-	-	0.964	0.918	0.909	0.881
		7.5	-	0.988	0.968	0.922	0.912	0.885
		5	1.018	0.992	0.972	0.925	0.916	0.888
	0		1.026	1.000	0.980	0.933	0.923	0.895
	* 2 Indoor unit is under than outdoor unit	-5	1.026	1.000	0.980	0.933	0.923	0.895
		-7.5	-	1.000	0.980	0.933	0.923	0.895
		-10	-	-	0.980	0.933	0.923	0.895
		-15	-	-	-	0.933	0.923	0.895

HEATING			Pipe length (m)					
			5	7.5	10	15	20	25
Height difference H (m)	* 1 Indoor unit is upper than outdoor unit.	15	-	-	-	0.943	0.916	0.896
		10	-	-	1.010	0.943	0.916	0.896
		7.5	-	1.000	1.010	0.943	0.916	0.896
		5	0.954	1.000	1.010	0.943	0.916	0.896
	0		0.954	1.000	1.010	0.943	0.916	0.896
	* 2 Indoor unit is under than outdoor unit	-5	0.949	0.995	1.005	0.939	0.912	0.892
		-7.5	-	0.993	1.002	0.936	0.909	0.890
		-10	-	-	0.999	0.934	0.907	0.887
		-15	-	-	-	0.925	0.898	0.878

Height difference H

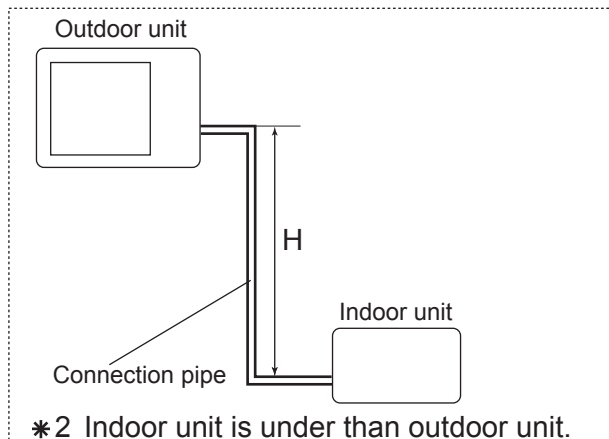
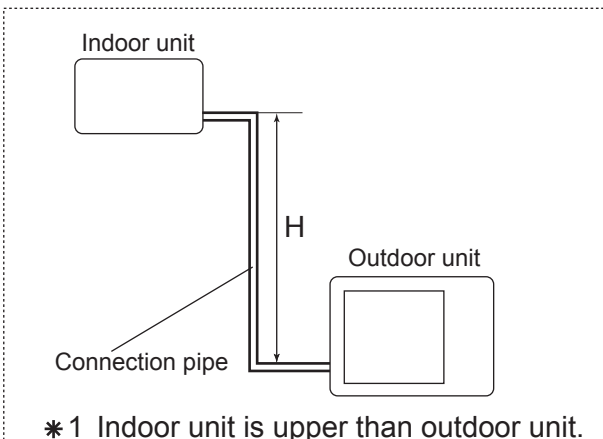

This table is created using the maximum capacity.

■ **MODEL : AO *A14L**

COOLING			Pipe length (m)					
			5	7.5	10	15	20	25
Height difference H (m)	* 1 Indoor unit is upper than outdoor unit.	15	-	-	-	0.953	0.950	0.947
		10	-	-	0.983	0.968	0.966	0.962
		7.5	-	0.988	0.987	0.972	0.970	0.966
		5	0.992	0.992	0.991	0.976	0.974	0.970
	* 2 Indoor unit is under than outdoor unit	0	1.000	1.000	0.999	0.984	0.982	0.978
		-5	1.000	1.000	0.999	0.984	0.982	0.978
		-7.5	-	1.000	0.999	0.984	0.982	0.978
		-10	-	-	0.999	0.984	0.982	0.978
		-15	-	-	-	0.984	0.982	0.978

HEATING			Pipe length (m)					
			5	7.5	10	15	20	25
Height difference H (m)	* 1 Indoor unit is upper than outdoor unit.	15	-	-	-	0.918	0.891	0.862
		10	-	-	0.981	0.918	0.891	0.862
		7.5	-	1.000	0.981	0.918	0.891	0.862
		5	0.994	1.000	0.981	0.918	0.891	0.862
	* 2 Indoor unit is under than outdoor unit	0	0.994	1.000	0.981	0.918	0.891	0.862
		-5	0.989	0.995	0.976	0.914	0.886	0.858
		-7.5	-	0.993	0.974	0.912	0.884	0.856
		-10	-	-	0.972	0.909	0.882	0.854
		-15	-	-	-	0.900	0.873	0.845

Height difference H

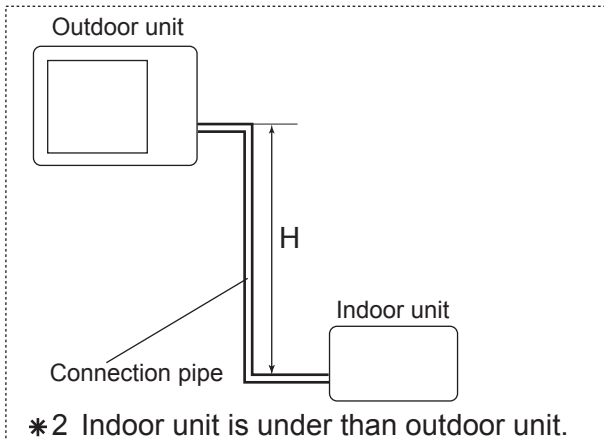
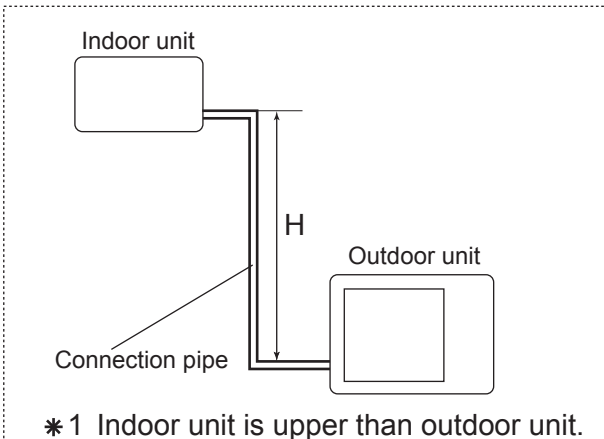

6. ADDITIONAL CHARGE CALCULATION

■ MODEL : AO*A12L

Refrigerant type	R410A	
Refrigerant amount	g	1150

● REFRIGERANT CHARGE

Pipe length	m	~ 15	20	25	20g/m
Additional charge	g	0 (Chargeless)	+100	+200	

■ MODEL : AO*A14L

Refrigerant type	R410A	
Refrigerant amount	g	1250

● REFRIGERANT CHARGE

Pipe length	m	~ 15	20	25	20g/m
Additional charge	g	0 (Chargeless)	+100	+200	

7. AIR FLOW

■ MODEL : AO *A12L

● COOLING

Number of rotations (r.p.m)	Air flow	
	770	m ³ /h
l/s		494
CFM		1048

● HEATING

Number of rotations (r.p.m)	Air flow	
	700	m ³ /h
l/s		453
CFM		959

■ MODEL : AO *A14L

● COOLING

Number of rotations (r.p.m)	Air flow	
	820	m ³ /h
l/s		531
CFM		1124

● HEATING

Number of rotations (r.p.m)	Air flow	
	750	m ³ /h
l/s		483
CFM		1024

8. OPERATION NOISE

8-1. NOISE LEVEL CURVE

■ COOLING

● MODEL : AO*A12L

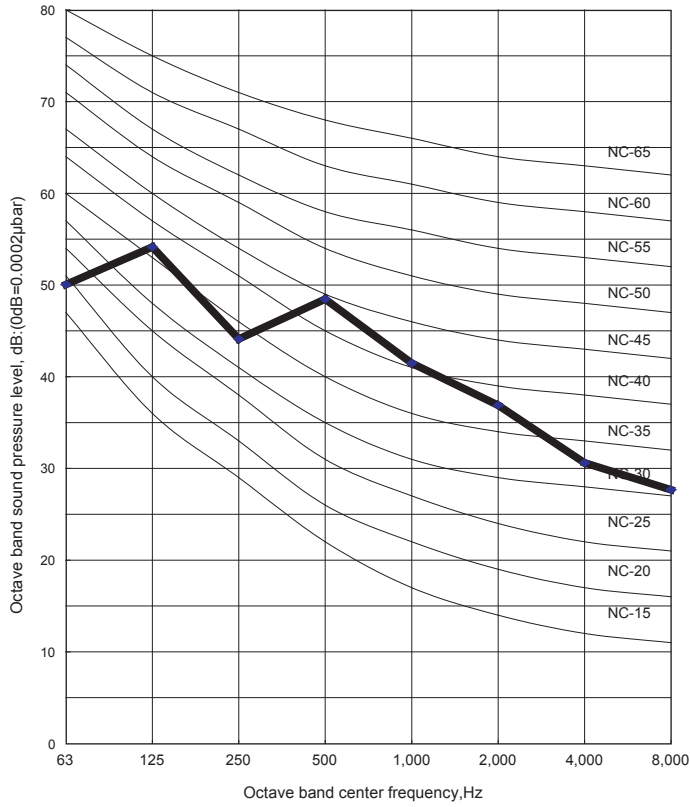

● MODEL : AO*A14L

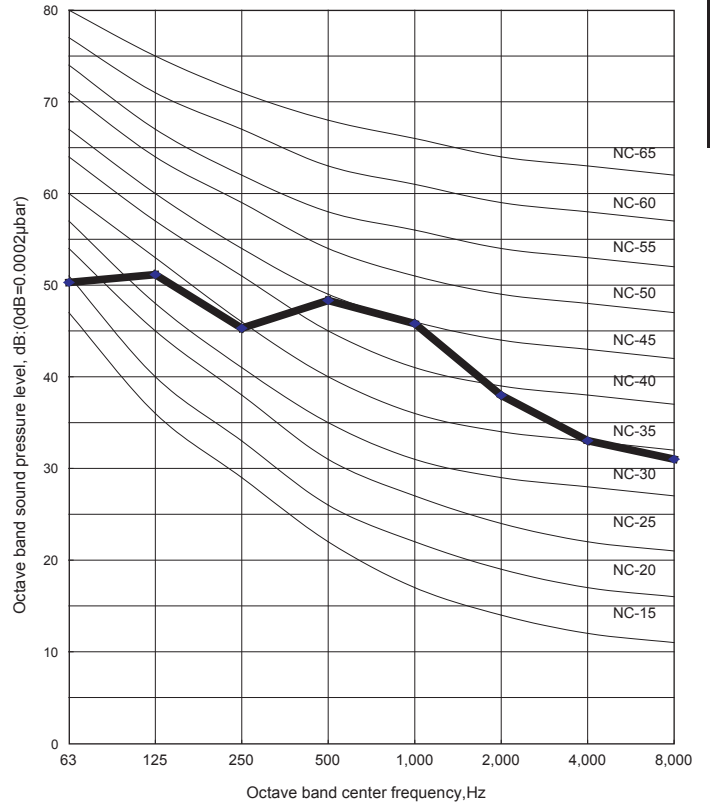

■ HEATING

● MODEL : AO*A12L

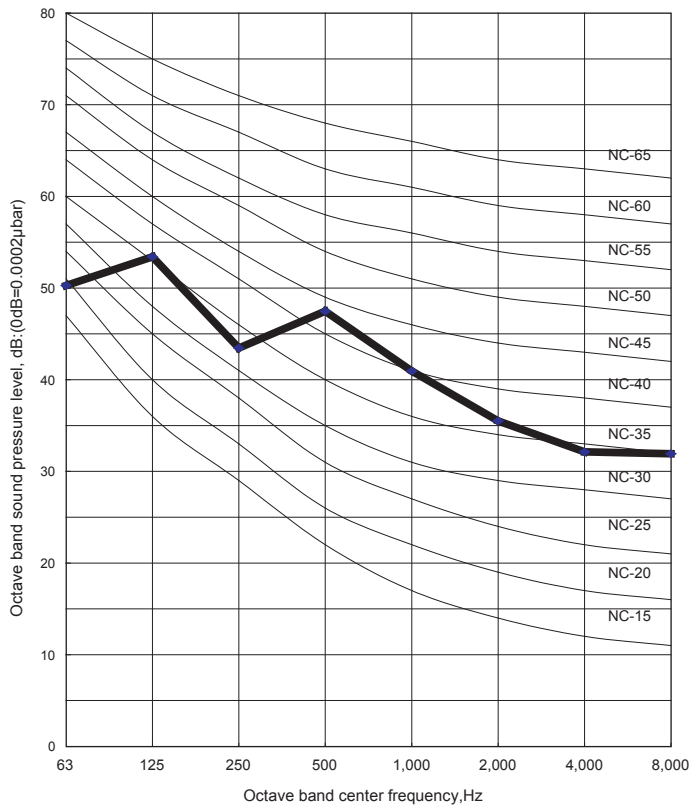

● MODEL : AO*A14L

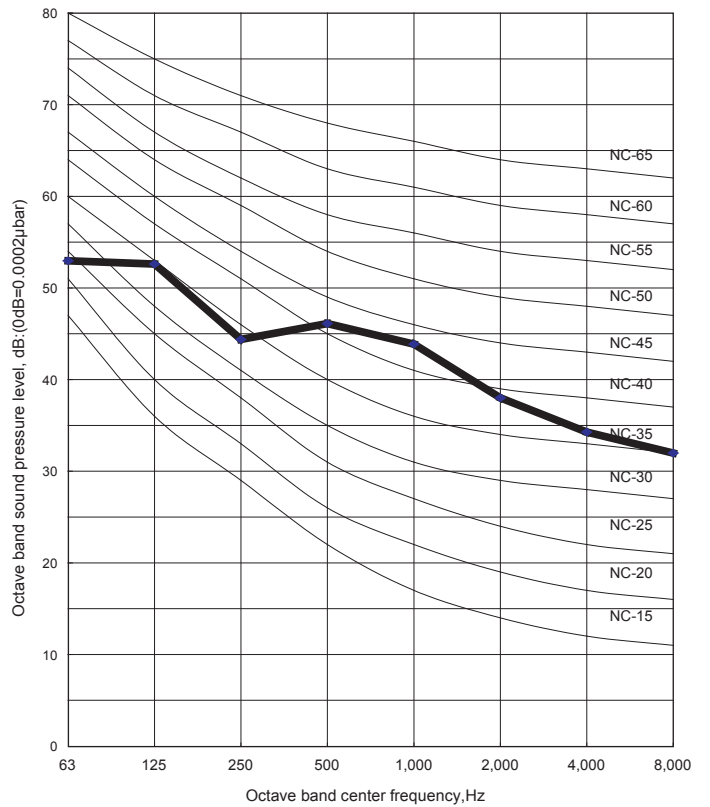

OUTDOOR UNIT
AO*A12-14L

OUTDOOR UNIT
AO*A12-14L

8-2. SOUND LEVEL CHECK POINT

OUTDOOR UNIT
AO*#A12-14L

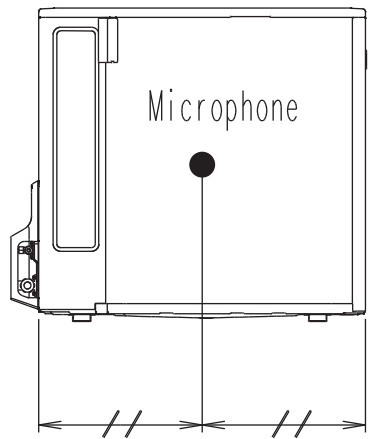
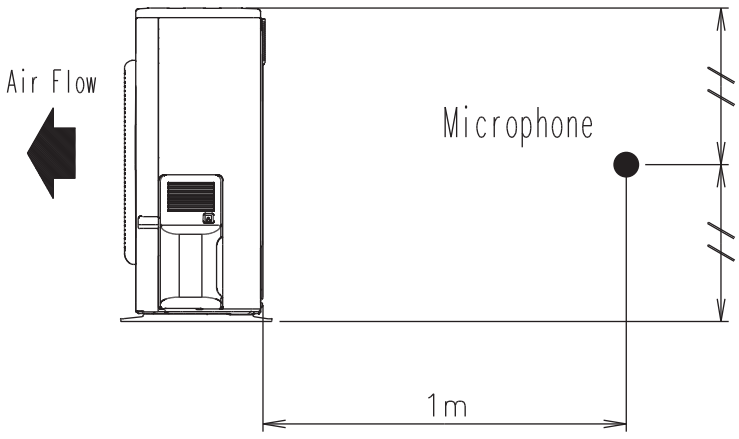

OUTDOOR UNIT
AO*#A12-14L

9. ELECTRIC CHARACTERISTICS

Model Name			AO * A12L	AO * A14L
Power Supply	Voltage	V	230~	
	Frequency	Hz	50	
Max Operating Current		A	10.0	12.5
Starting Current		A	4.9	5.9
*1) Wiring Spec.	Main Fuse (Circuit breaker) Current	A	20	20
	Power Cable	mm ²	4.0	
	*2) Limited wiring length	m	36	28

*1) Wiring Spec.

Selected Sample

(Selected based on Japan Electrotechnical Standard and Codes Committee E0005)

*2) Limited Wiring length

This is the wiring length in case voltage descent is less than 2%.

When the wiring length becomes long, please select the wiring of a more larger diameter.

10. SAFETY DEVICES

	Protection form	Model	
		AO * A12L	AO * A14L
Circuit protection	Current fuse (NEAR THE TERMINAL)	20A 250V	
		5A 250V	
	Current fuse (MAIN PRINTED CIRCUIT BOARD)	15A 250V	
		3.15A 250V	
Fan motor protection	Thermal protection program	OFF : 100 ⁺¹⁵ ₋₁₀ °C ON : 95 ⁺¹⁵ ₋₁₀ °C	
Compressor protection	Thermal protection program (COMPRESSOR TEMP.)	OFF : 110°C ON : After 40 minutes	
	Thermal protection program (DISCHARGE TEMP.)	OFF : 110°C ON : After 7 minutes	

OUTDOOR UNIT
AO*A12-14L

OUTDOOR UNIT
AO*A12-14L

OUTDOOR UNIT

2. SINGLE TYPE :

AO * B12LACL

AO * B12LALL

AO * B14LACL

AO * B14LALL

1. SPECIFICATIONS

OUTDOOR UNIT
AO*B12-14L

OUTDOOR UNIT
AO*B12-14L

Type			INVERTER HEATPUMP			
Model name			AO*B12LACL AO*B12LALL	AO*B14LACL AO*B14LALL		
Power source			230V ~ 50Hz			
Available voltage range			198-264V ~ 50Hz			
Starting current		A	4.9	5.9		
Fan	Airflow rate	Cooling	m ³ /h	1780	1910	
		Heating		1630	1740	
	Type × Q'ty		Propeller × 1			
	Motor output		W	54		
Sound pressure level		Cooling	dB(A)	47	49	
		Heating		48	49	
Heat exchanger type		Dimensions (H × W × D)	mm	546 × 876 × 18.2		
		Fin pitch		546 × 842 × 18.2		
		Rows x Stages	1.30			
		Pipe type	2 × 26			
		Fin type	Copper			
Compressor		Type × Q'ty		Twin Rotary × 1		
		Motor output	W	1100		
Refrigerant		Type		R410A		
		Charge	g	1150	1250	
Refrigerant oil		Type		POE		
Enclosure		Material		Steel sheet		
		Colour		Beige (10YR7.5/1.0NN)		
Dimensions (H×W×D)		Net		mm		
		Gross		578 × 790 × 300		
Weight		Net		kg(lb.)	40 (88)	
		Gross		44 (97)	44 (97)	
Connection pipe		Size	Liquid	mm		
			Gas	Φ 6.35 (Φ 1/4 in.)		
		Method		Flare		
		Max. length		m	25(chargeless:15)	
		Max. height difference			15	
Operation range		Cooling	°C	-10 to 46		
		Heating		-15 to 24		

Note :

Specifications are based on the following conditions.

Cooling : Indoor temperature of 27°CDB/19°CWB. and outdoor temperature of 35°CDB/24°CWB.

Heating : Indoor temperature of 20°CDB/15°CWB. and outdoor temperature of 7°CDB/6°CWB.

Pipe length : 7.5 m, Height difference : 0 m. (Outdoor unit - Indoor unit)

2. DIMENSIONS

■ MODEL : AO*B12L, AO*B14L

(Unit : mm)

OUTDOOR UNIT
AO*B12-14L

OUTDOOR UNIT
AO*B12-14L

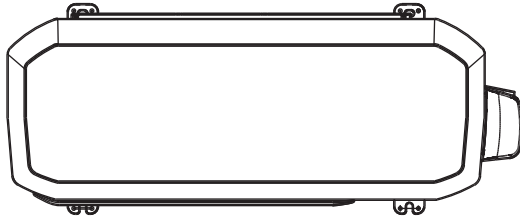

Top view

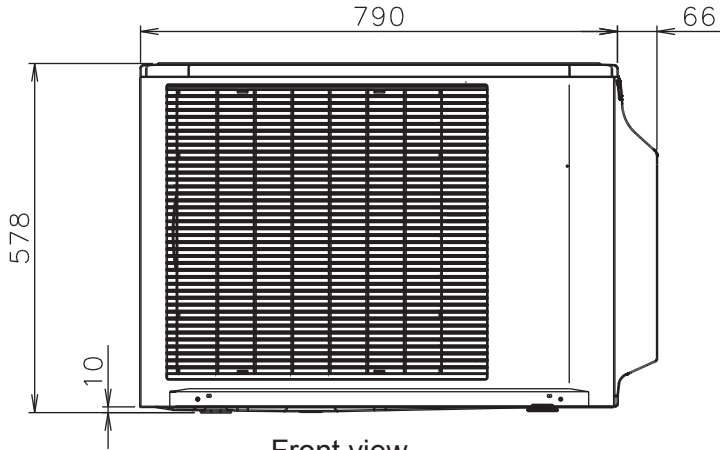

Front view

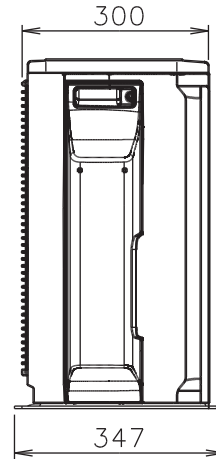

Side view

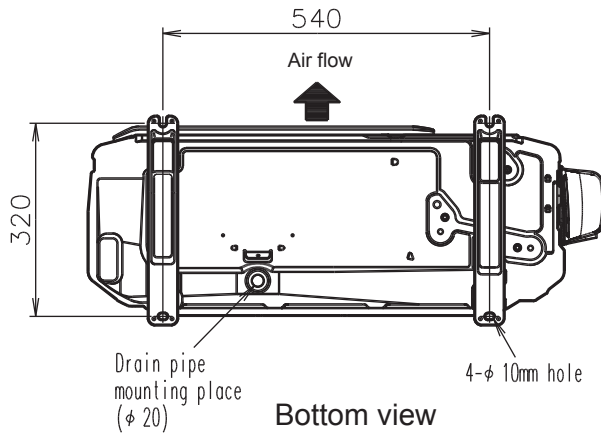

Bottom view

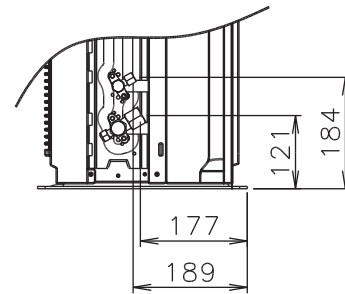

■ MOUNTING POSITION

When there are obstacles at the back or front sides.

When there are obstacles at the back, side(s), and top.

When there are obstacles at the back, side with the installation of more than one unit.

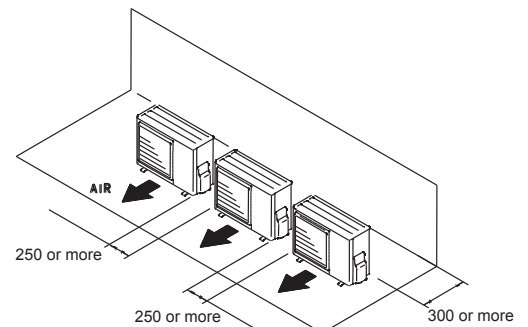
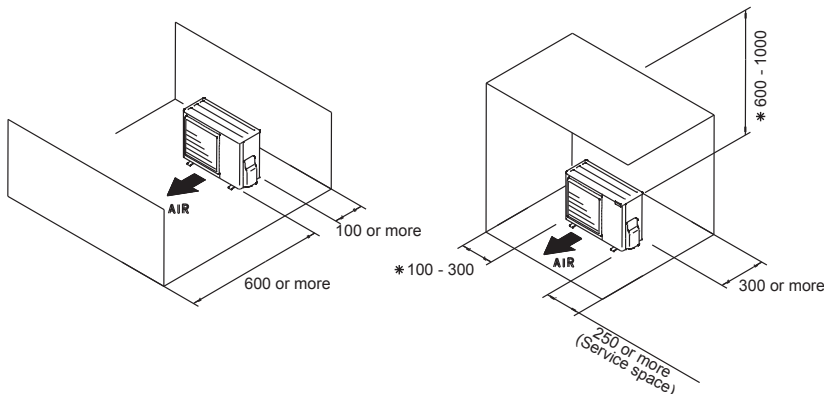

* If the space is larger than that is stated, the condition will be the same as that are no obstacles.

3. REFRIGERANT CIRCUIT

■ MODEL : AO*B12L, AO*B14L

OUTDOOR UNIT
AO*B12-14L

OUTDOOR UNIT
AO*B12-14L

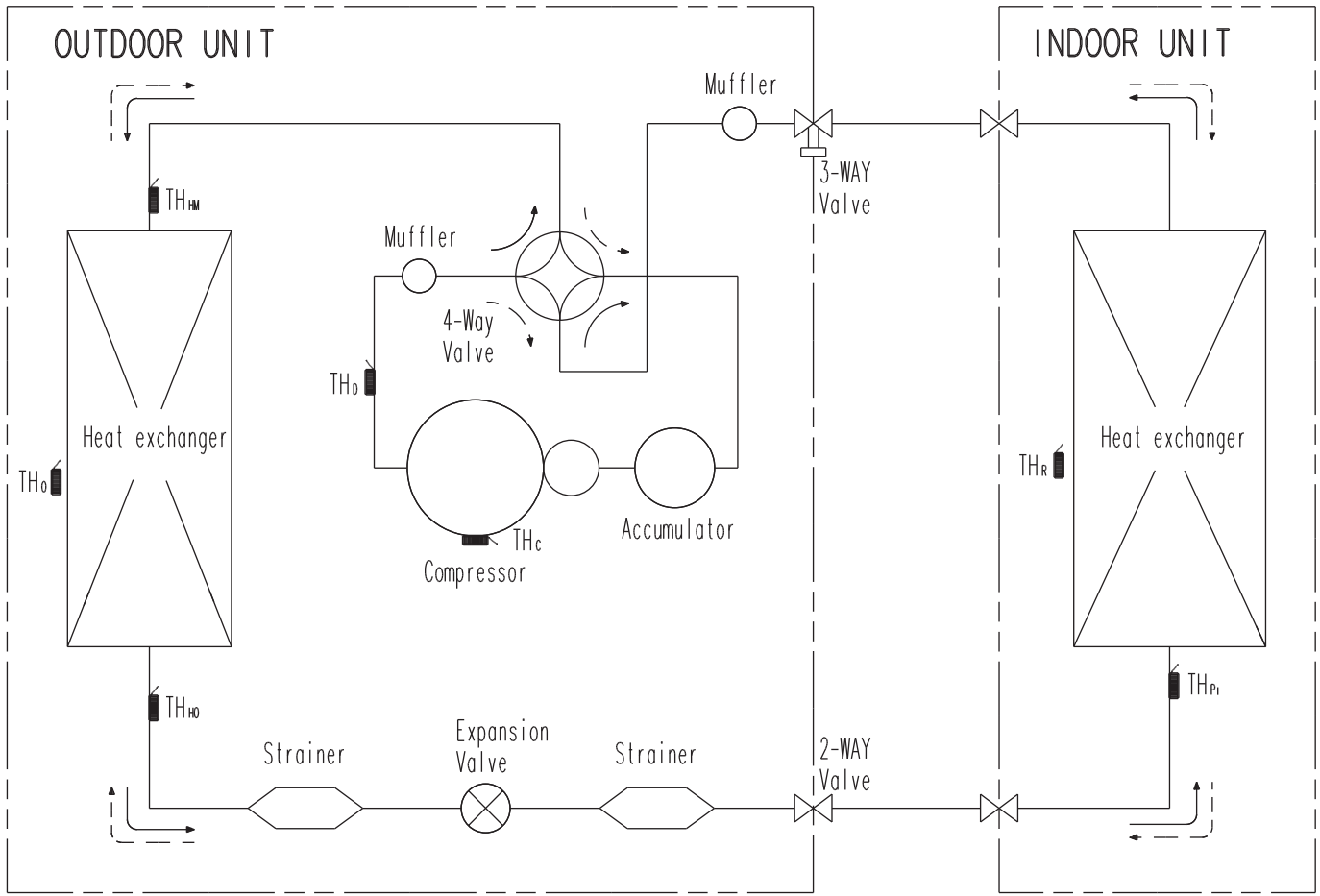

4. WIRING DIAGRAMS

■ MODEL : AO*B12L, AO*B14L

OUTDOOR UNIT
AO*B12-14L

OUTDOOR UNIT
AO*B12-14L

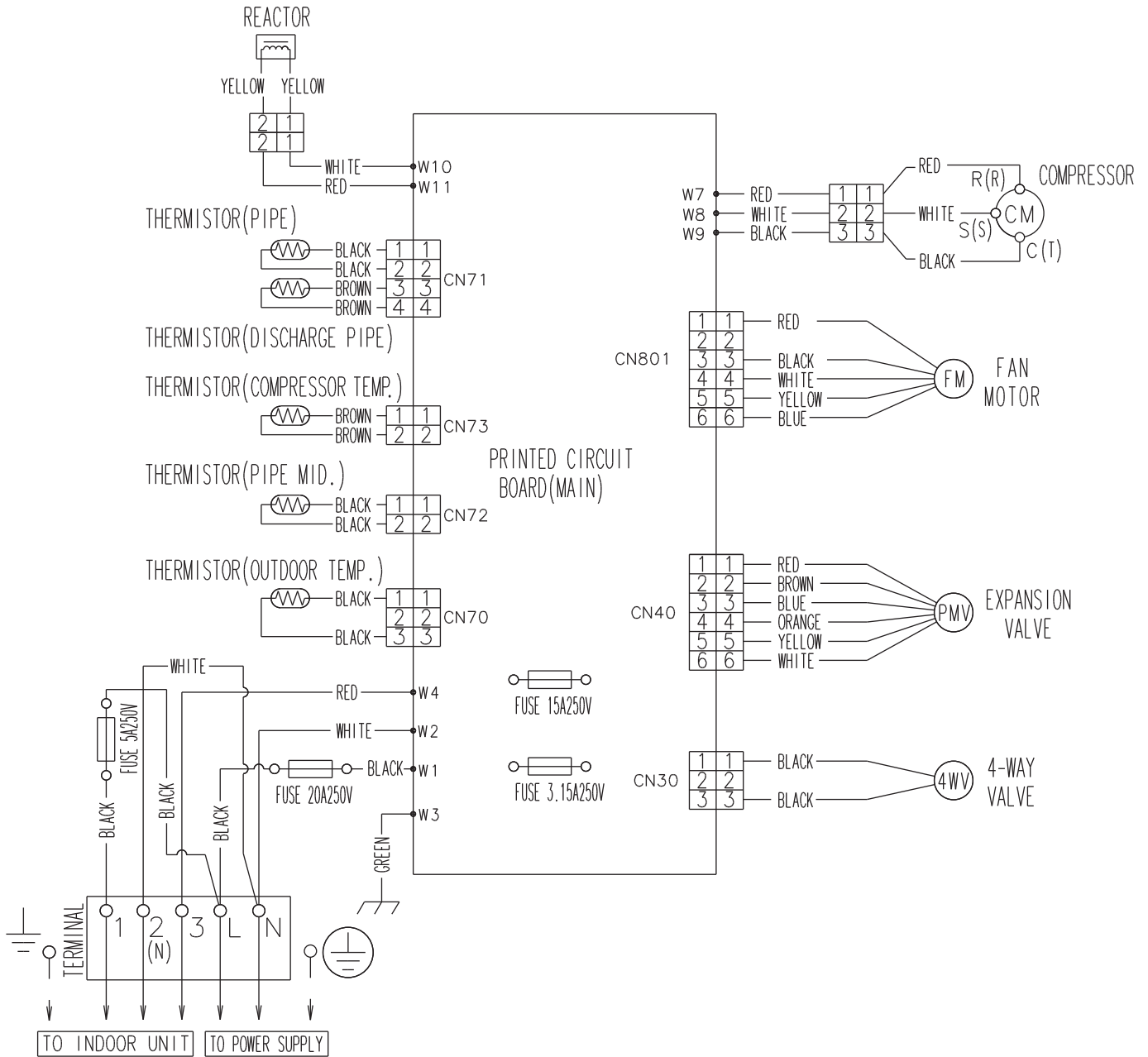

5. CAPACITY COMPENSATION RATE FOR PIPE LENGTH AND HEIGHT DIFFERENCE

MODEL : AO*B12L

OUTDOOR UNIT
AO*B12-14L

OUTDOOR UNIT
AO*B12-14L

COOLING			Pipe length (m)					
			5	7.5	10	15	20	25
Height difference H (m)	* 1 Indoor unit is upper than outdoor unit.	15	-	-	-	0.903	0.894	0.867
		10	-	-	0.964	0.918	0.909	0.881
		7.5	-	0.988	0.968	0.922	0.912	0.885
		5	1.018	0.992	0.972	0.925	0.916	0.888
		0	1.026	1.000	0.980	0.933	0.923	0.895
	* 2 Indoor unit is under than outdoor unit	-5	1.026	1.000	0.980	0.933	0.923	0.895
		-7.5	-	1.000	0.980	0.933	0.923	0.895
		-10	-	-	0.980	0.933	0.923	0.895
-15		-	-	-	0.933	0.923	0.895	

HEATING			Pipe length (m)					
			5	7.5	10	15	20	25
Height difference H (m)	* 1 Indoor unit is upper than outdoor unit.	15	-	-	-	0.943	0.916	0.896
		10	-	-	1.010	0.943	0.916	0.896
		7.5	-	1.000	1.010	0.943	0.916	0.896
		5	0.954	1.000	1.010	0.943	0.916	0.896
		0	0.954	1.000	1.010	0.943	0.916	0.896
	* 2 Indoor unit is under than outdoor unit	-5	0.949	0.995	1.005	0.939	0.912	0.892
		-7.5	-	0.993	1.002	0.936	0.909	0.890
		-10	-	-	0.999	0.934	0.907	0.887
-15		-	-	-	0.925	0.898	0.878	

Height difference H

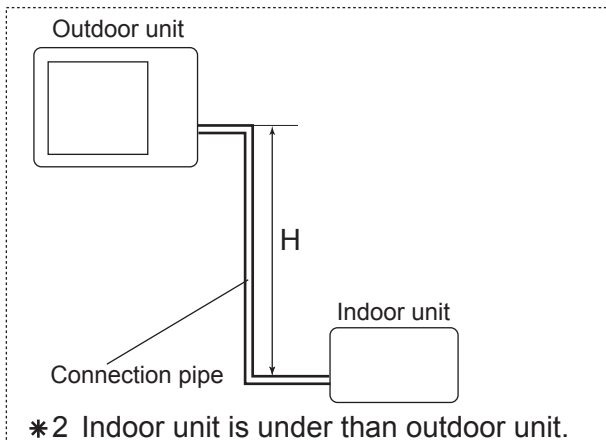
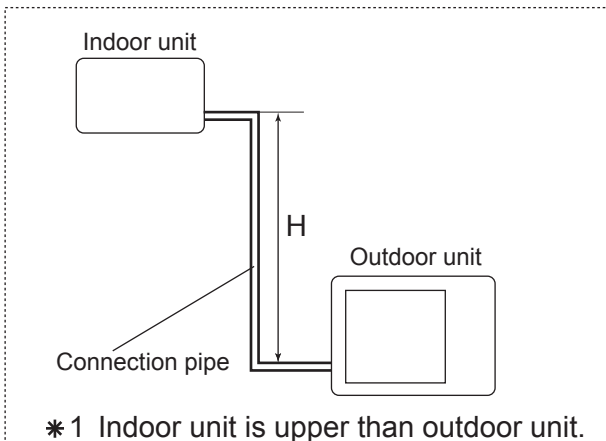

■ MODEL : AO*B14L

COOLING			Pipe length (m)					
			5	7.5	10	15	20	25
Height difference H (m)	* 1 Indoor unit is upper than outdoor unit.	15	-	-	-	0.953	0.950	0.947
		10	-	-	0.983	0.968	0.966	0.962
		7.5	-	0.988	0.987	0.972	0.970	0.966
		5	0.992	0.992	0.991	0.976	0.974	0.970
	0		1.000	1.000	0.999	0.984	0.982	0.978
	* 2 Indoor unit is under than outdoor unit	-5	1.000	1.000	0.999	0.984	0.982	0.978
		-7.5	-	1.000	0.999	0.984	0.982	0.978
		-10	-	-	0.999	0.984	0.982	0.978
-15		-	-	-	0.984	0.982	0.978	

HEATING			Pipe length (m)					
			5	7.5	10	15	20	25
Height difference H (m)	* 1 Indoor unit is upper than outdoor unit.	15	-	-	-	0.918	0.891	0.862
		10	-	-	0.981	0.918	0.891	0.862
		7.5	-	1.000	0.981	0.918	0.891	0.862
		5	0.994	1.000	0.981	0.918	0.891	0.862
	0		0.994	1.000	0.981	0.918	0.891	0.862
	* 2 Indoor unit is under than outdoor unit	-5	0.989	0.995	0.976	0.914	0.886	0.858
		-7.5	-	0.993	0.974	0.912	0.884	0.856
		-10	-	-	0.972	0.909	0.882	0.854
-15		-	-	-	0.900	0.873	0.845	

Height difference H

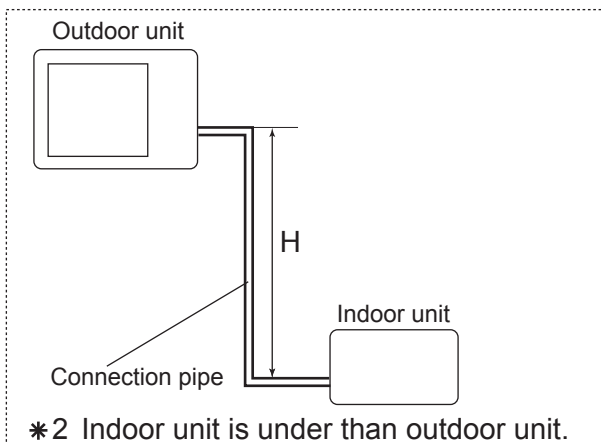
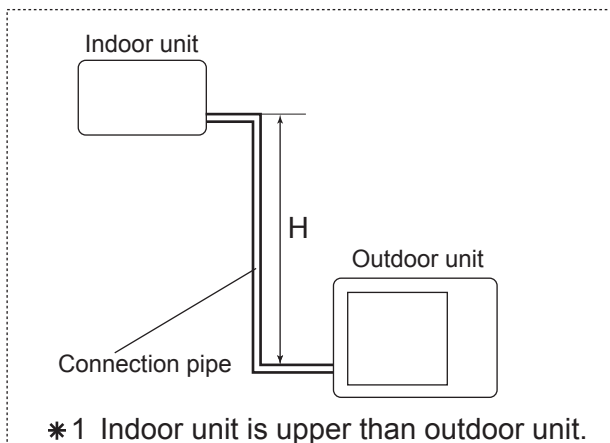

6. ADDITIONAL CHARGE CALCULATION

■ MODEL : AO*B12L

Refrigerant type		R410A
Refrigerant amount	g	1150

● REFRIGERANT CHARGE

Pipe length	m	~ 15	20	25	20g/m
Additional charge	g	0 (Chargeless)	+100	+200	

■ MODEL : AO*B14L

Refrigerant type		R410A
Refrigerant amount	g	1250

● REFRIGERANT CHARGE

Pipe length	m	~ 15	20	25	20g/m
Additional charge	g	0 (Chargeless)	+100	+200	

7. AIR FLOW

■ MODEL : AO*B12L

● COOLING

Number of rotations (r.p.m)	Air flow	
	770	m ³ /h
l/s		494
CFM		1048

● HEATING

Number of rotations (r.p.m)	Air flow	
	700	m ³ /h
l/s		453
CFM		959

■ MODEL : AO*B14L

● COOLING

Number of rotations (r.p.m)	Air flow	
	820	m ³ /h
l/s		531
CFM		1124

● HEATING

Number of rotations (r.p.m)	Air flow	
	750	m ³ /h
l/s		483
CFM		1024

8. OPERATION NOISE

8-1. NOISE LEVEL CURVE

MODEL : AO*B12L

COOLING

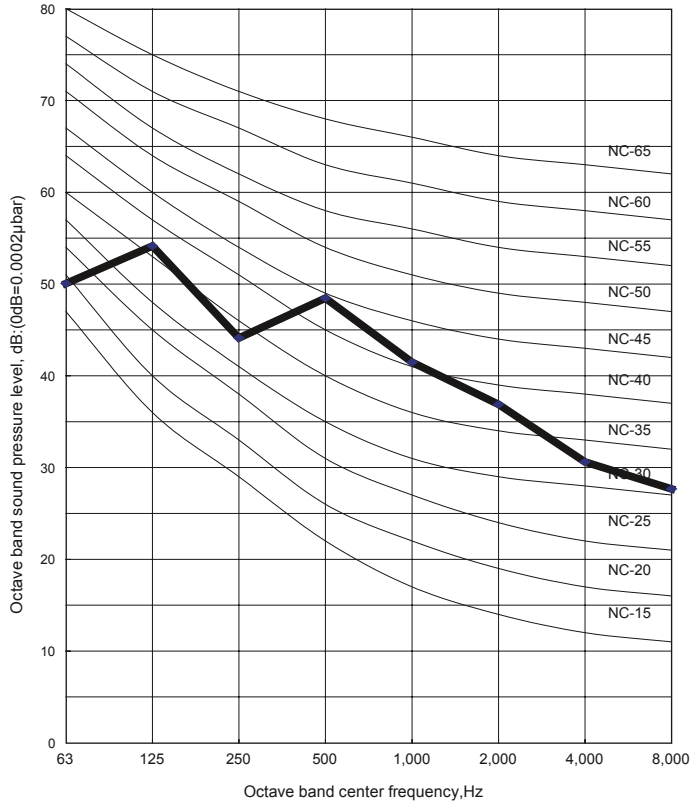

HEATING

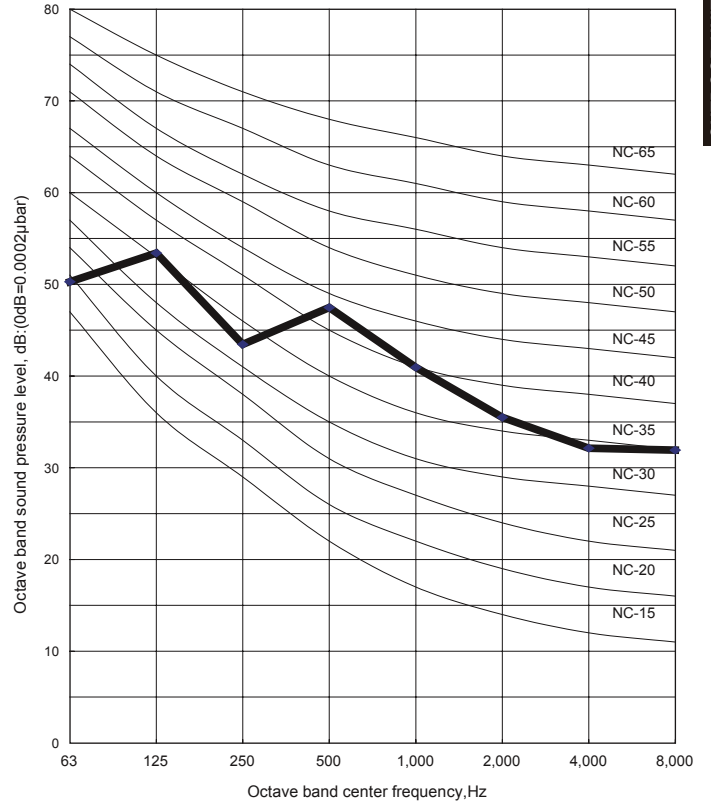

MODEL : AO*B14L

COOLING

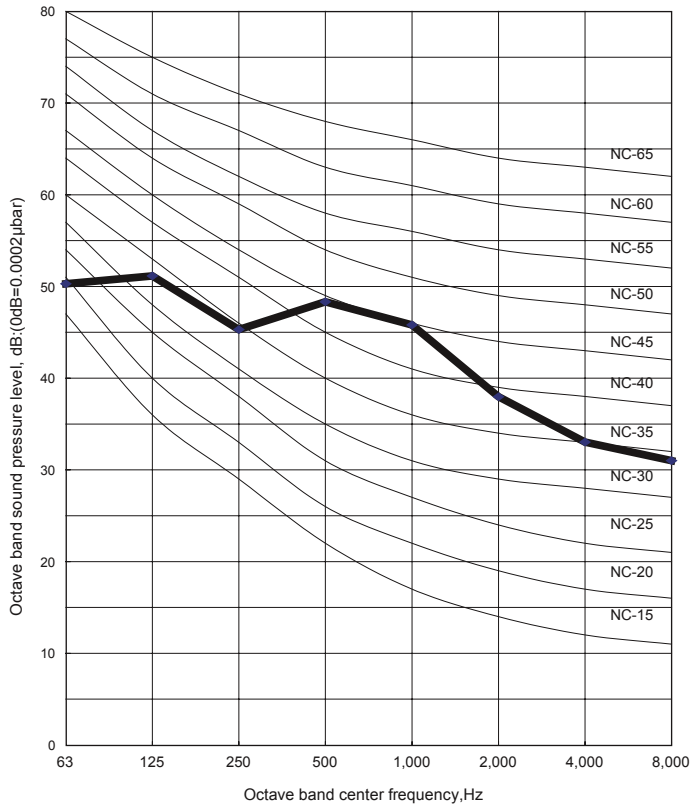

HEATING

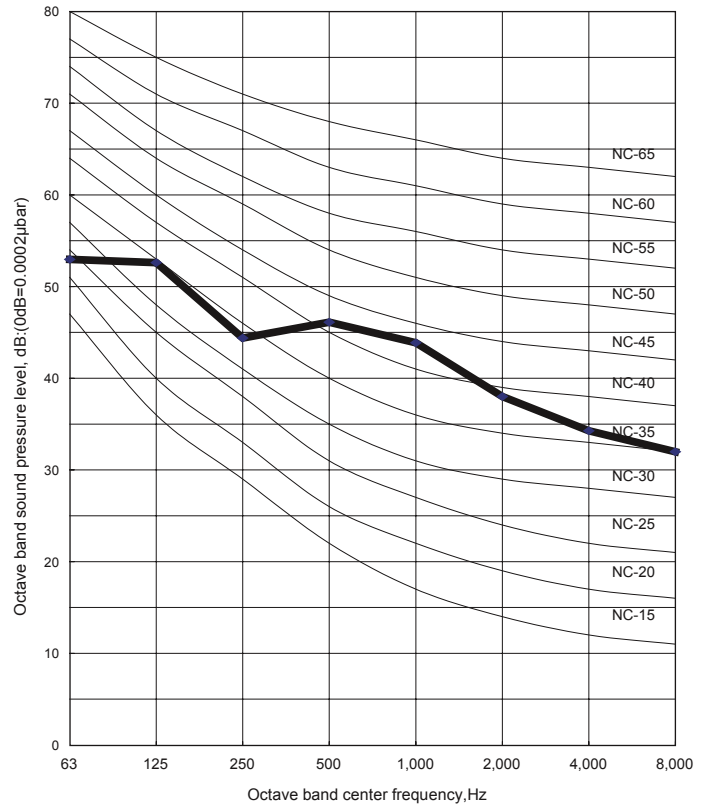

8-2. SOUND LEVEL CHECK POINT

OUTDOOR UNIT
AO*B12-14L

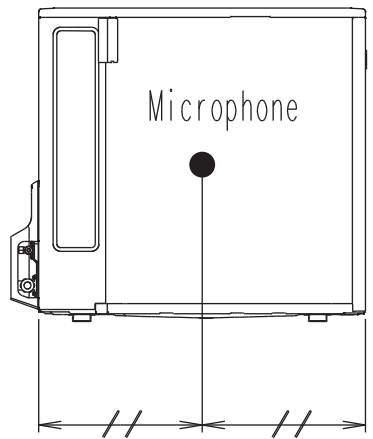
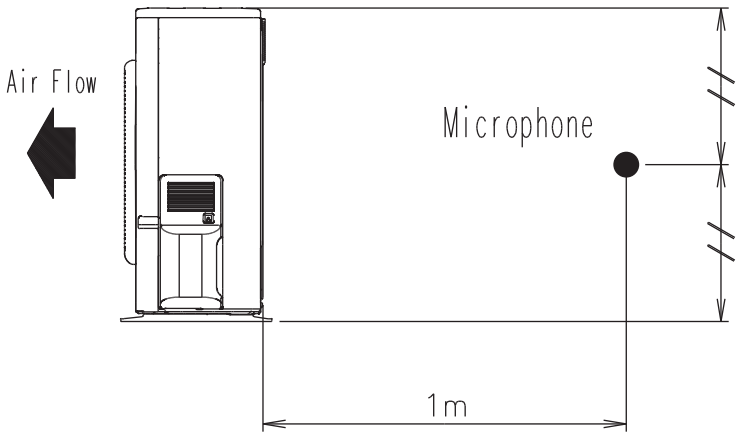

OUTDOOR UNIT
AO*B12-14L

9. ELECTRIC CHARACTERISTICS

Model name			AO* B12L	AO* B14L
Power supply	Voltage	V	230 ~	
	Frequency	Hz	50	
Max. operating current		A	10.0	12.5
Starting current		A	4.9	5.9
*1) Wiring spec.	Main fuse (Circuit breaker) current	A	20	20
	Power cable	mm ²	4.0	
	*2)Limited wiring length	m	36	28

*1) Wiring spec.

Selected sample

(Selected based on Japan Electrotechnical Standard and Codes Committee E0005)

*2) Limited wiring length

This is the wiring length in case voltage descent is less than 2%.

When the wiring length becomes long, please select the wiring of a more larger diameter.

10. SAFETY DEVICES

	Protection form	Model	
		AO *B12L	AO *B14L
Circuit protection	Current fuse (NEAR THE TERMINAL)	20A 250V	
		5A 250V	
	Current fuse (MAIN PRINTED CIRCUIT BOARD)	15A 250V	
		3.15A 250V	
Fan motor protection	Thermal protection program	OFF : 100 ⁺¹⁵ ₋₁₀ °C ON : 95 ⁺¹⁵ ₋₁₀ °C	
Compressor protection	Thermal protection program (COMPRESSOR TEMP.)	OFF : 110°C ON : After 40 minutes	
	Thermal protection program (DISCHARGE TEMP.)	OFF : 110°C ON : After 7 minutes	

OUTDOOR UNIT
AO*B12-14L

OUTDOOR UNIT
AO*B12-14L