

INDOOR UNIT

1. CASSETTE TYPE :

AU * A18LALN

AU * A24LALN

1. FEATURE

■ MODELS :

AU*A18LALN

AU*A24LALN



■ FEATURES

● Energy saving

- All DC design
- Heat exchange efficiency increased and larger air flow by adoption of new type turbo fan

● Advancement in comfort

- Quiet operation was realized by adoption of new type turbo fan
- Improvement of air stream

● Improvement of installation & maintenance

- COMPACT DESIGN

Fits the European size ceiling.

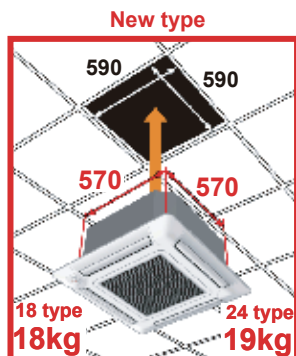

● Easy maintenance

① Maintenance of fan motor and fan

Maintenance of fan motor and fan can be done easily after taking off the panel, since bell-mouth can be removed easily

- A : Fan motor
- B : 2 stage turbo fan
- C : Bell-mouth
- D : Panel

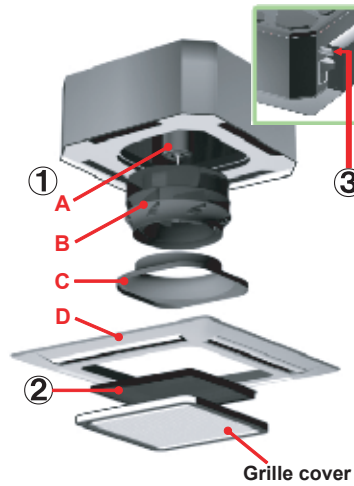

② Long life filter

: standard equipment

③ Adaptation of transparent drainage parts

Easy check of operation of drain-up kit when you install

● Easy installation

New type

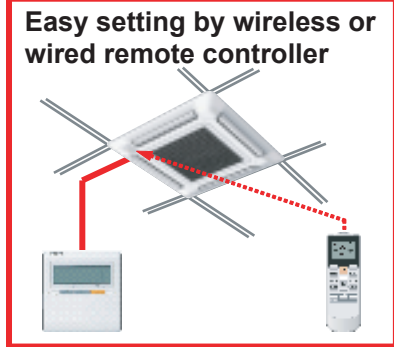

FUNCTION SETTING

● Outlet direction selection

- Performs operation matched to the number of outlets when 4 directions are unnecessary and outlets are blocked when the ceiling cassette is installed in a corner, etc.

4-way direction 3-way direction



4-way direction mode: Set when there are 4 outlets (shipped state).

3-way direction mode: Set when there are 3 outlets.

● Ceiling switching function

Air reaches sufficiently up to 3m height, even it is compact cassette type.

Also delivers air to high ceilings by selecting the mode and raising the air flow according to the height of the ceiling.

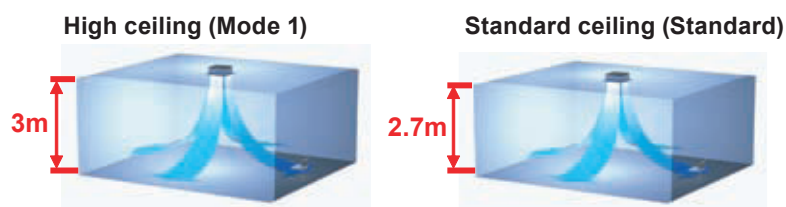

Standard...Operates at normal air flow.

Mode 1 ...Air flow becomes greater than normal.

● Filter sign

The indoor unit has sign to inform the user that it is time to clean the filter

● Cooling room temperature correction

● Heating room temperature correction

● Auto restart

The units restart automatically when the current was returned even when there was a power interruption during operation.

● Room temperature sensor switching

Switches from room temperature judgment by room temperature sensor attached to indoor unit body to room temperature judgment by room temperature sensor attached to wired remote controller.

● Economy operation

The power consumption can be reduced.

Powerful mode ...Standard

Soft mode ...Performs operation which reduces the power consumption

2. COMBINATION

2-1. OUTDOOR UNIT

■ MODELS :

AO*A18LACL

AO*A24LACL



2-2. REMOTE CONTROLLER

2-2-1. WIRED REMOTE CONTROLLER

■ MODEL : UTB-*UD

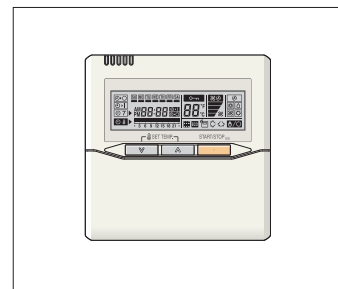

2-2-2. WIRELESS REMOTE CONTROLLER

■ MODEL : UTB-*NA



2-3. DECORATION PANEL

■ MODEL : UTG-UF*A-W

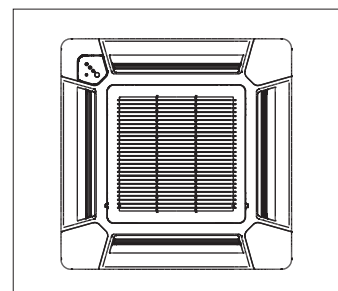

CAUTION

Remote controller and decoration panel are not supplied with the indoor unit.
Separate purchase is necessary.

3. SPECIFICATIONS

Type			CASSETTE MODEL		
Model name			INVERTER HEATPUMP		
Power source			AU * A18LALN	AU * A24LALN	
Available voltage range			230V~ 50Hz		
European energy label			198 - 264V~ 50Hz		
European energy label			Cooling	A	A
			Heating	A	A
Capacity	Cooling	Rated	kW	5.2	7.1
			BTU/h	17700	24200
		Min-Max	kW	0.9 - 5.9	0.9 - 8.0
			BTU/h	3100 - 20100	3100 - 27300
	Heating	Rated	kW	6.0	8.0
			BTU/h	20500	27300
Min-Max		kW	0.9 - 7.5	0.9 - 9.1	
		BTU/h	3100 - 25600	3100 - 31000	
Input power	Cooling	kW	Rated	1.62	2.21
			Min-Max	0.09 - 2.07	0.09 - 2.61
	Heating		Rated	1.66	2.21
			Min-Max	0.09 - 2.52	0.09 - 2.80
Current	Cooling	A	Rated	7.1	9.7
			Max	9.1	11.5
	Heating		Rated	7.3	9.7
			Max	11.1	12.3
EER	Cooling	kW/kW	3.21	3.21	
COP	Heating		3.61	3.61	
Moisture removal			l/h (pints/h)	2.2 (3.9)	2.7 (4.8)
Fan	Airflow rate	Cooling	High	680	930
			Med	580	830
			Low	490	600
			Quiet	410	450
		Heating	High	800	930
			Med	680	860
			Low	580	700
			Quiet	450	530
	Type × Q'ty			Turbo × 1	
	Motor output			W	42
Sound pressure level	Cooling	dB(A)	High	38	49
			Med	34	44
			Low	30	36
			Quiet	26	30
	Heating		High	43	49
			Med	38	45
			Low	34	40
			Quiet	30	33
Heat exchanger type	Dimensions (H × W × D)		mm	210 × 1310 × 13.3	210 × 1375 × 13.3
				210 × 1250 × 13.3	210 × 1310 × 13.3
	Fin pitch			1.20	1.45
	Rows × Stages			2 × 10	3 × 10
	Pipe type		Copper tube		
Fin type		Aluminium			
Enclosure		Material			PS
		Colour			WHITE Approximate colour of MUNSELL N 9.25/
Dimensions (H × W × D)	Net	Unit	mm	245 × 570 × 570	
		Panel		49 × 700 × 700	
	Gross	Unit		265 × 730 × 625	
		Panel		120 × 765 × 755	
Weight	Net	Unit	kg(lb.)	15 (33)	17 (37)
		Panel		2.6 (5.7)	
	Gross	Unit		18 (40)	20 (44)
		Panel		4.5 (10.0)	
Connection pipe	Size	Liquid	mm	φ 6.35 (φ 1/4 in.)	φ 6.35 (φ 1/4 in.)
		Gas		φ 12.70 (φ 1/2 in.)	φ 15.88 (φ 5/8 in.)
	Method	Flare		Flare	
Operation range	Cooling	°C	18 to 32	18 to 32	
		%RH	80 or less	80 or less	
	Heating	°C	30 or less	30 or less	
Remote controller type			WIRED or WIRELESS		
Drain pipe	Material		ABS		
	Size		mm		
			Outer diameter : 25.4 / Inner diameter : 19.4		

Note :
 Specifications are based on the following conditions.
 Cooling : Indoor temperature of 27°CDB/19°CWB, and outdoor temperature of 35°CDB/24°CWB.
 Heating : Indoor temperature of 20°CDB/15°CWB, and outdoor temperature of 7°CDB/6°CWB.
 Pipe length : 7.5 m, Height difference : 0 m. (Outdoor unit - Indoor unit)
 Ceiling mode : Standard

4. DIMENSIONS

■ MODELS : AU*A18L, AU*A24L

(Unit : mm)

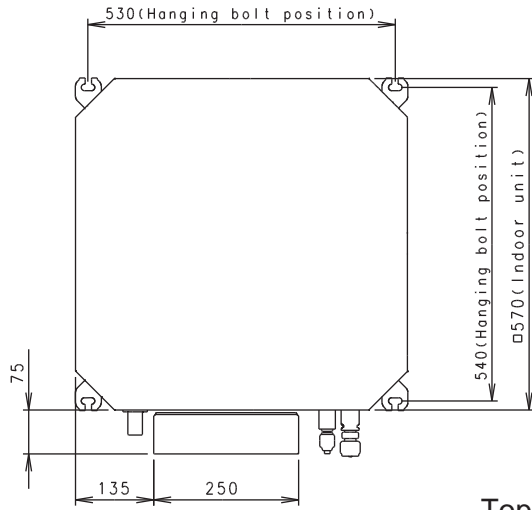

Top view

• Decoration panel mounting state

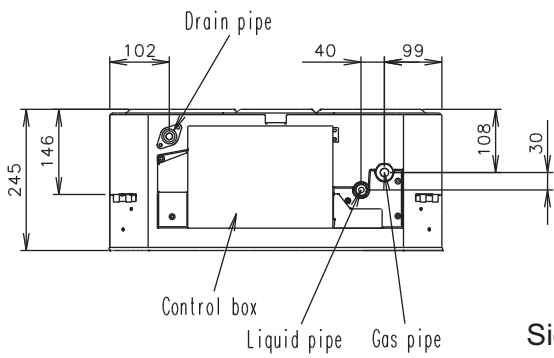
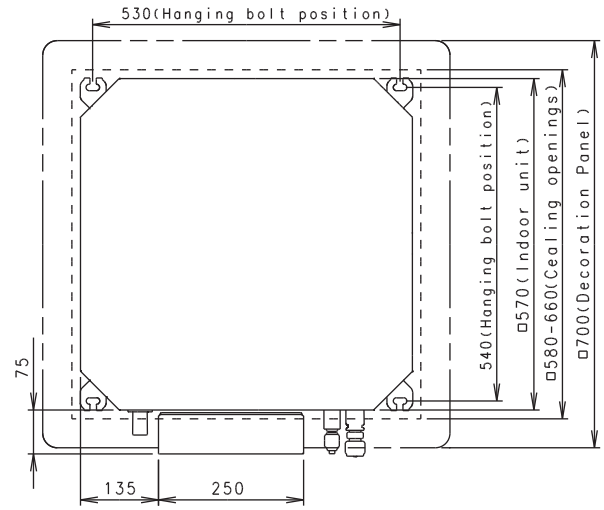

Side view

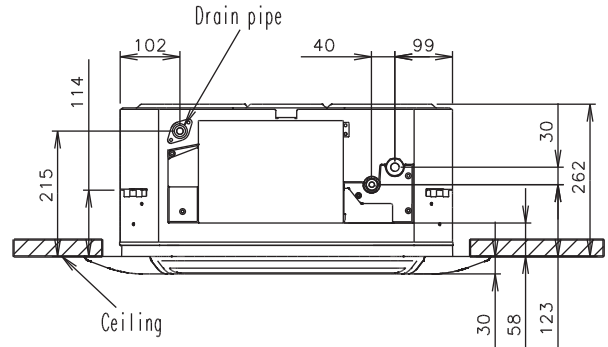

■ MODEL : UTG-UF*A-W

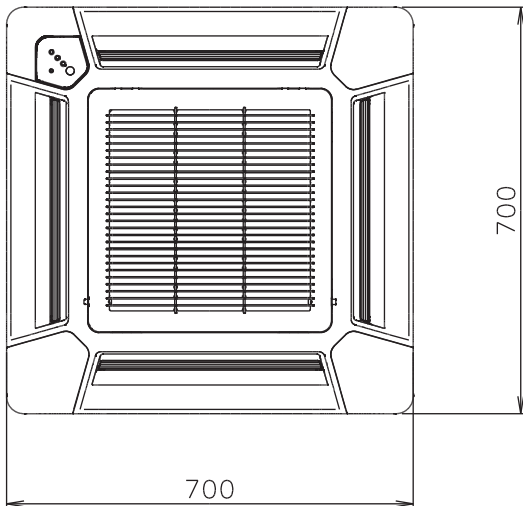

Bottom view

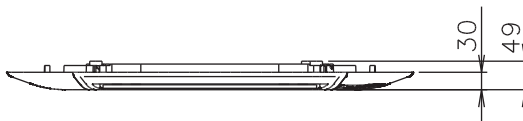

Side view

■ INSTALLATION PLACE

(Unit : mm)

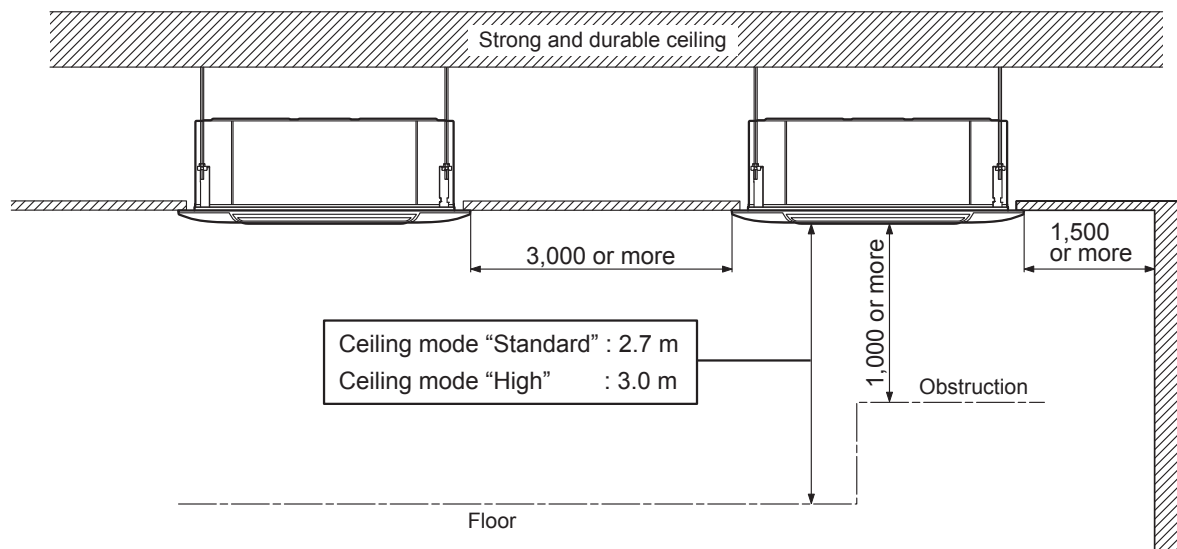

● 3-way directions setting

(Unit : mm)

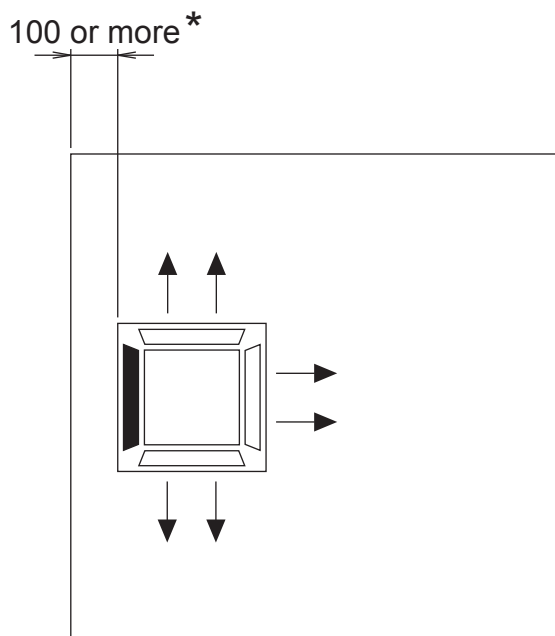

To set "3-way directions", the air outlet shutter plate (UTR-YDZA) sold separately must be installed and "outlet-direction" switched to "3-way" by remote controller.

*When installing the indoor unit, be careful about the maintenance hole

5. WIRING DIAGRAMS

MODELS : AU*A18L, AU*A24L

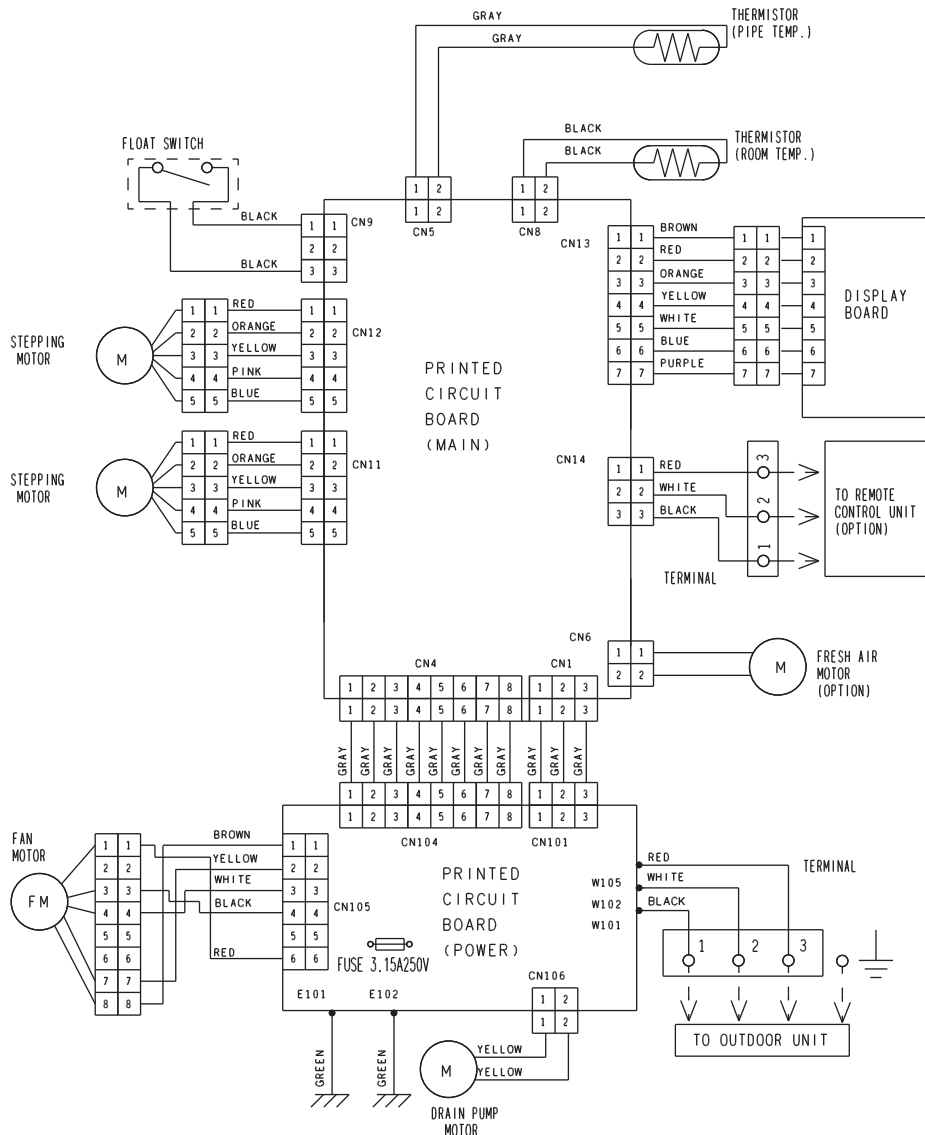

6. CAPACITY TABLE

6-1. COOLING CAPACITY

MODEL : AU*A18L

AFR	11.3
-----	------

		Indoor temperature																						
		18			21			23			25			27			29			32				
		12			15			16			18			19			21			23				
Outdoor temperature	°CDB	TC	SHC	PI	TC	SHC	PI	TC	SHC	PI	TC	SHC	PI	TC	SHC	PI	TC	SHC	PI	TC	SHC	PI		
	-10	4.45	3.38	0.44	4.96	3.40	0.44	5.13	3.69	0.44	5.47	3.71	0.45	5.64	4.00	0.45	5.97	3.99	0.46	6.31	4.25	0.46		
	0	4.35	3.32	0.51	4.85	3.34	0.52	5.01	3.64	0.52	5.34	3.65	0.52	5.51	3.94	0.53	5.84	3.92	0.53	6.17	4.18	0.54		
	5	4.23	3.26	0.63	4.71	3.28	0.64	4.87	3.57	0.64	5.19	3.58	0.65	5.35	3.86	0.65	5.67	3.85	0.66	6.00	4.10	0.66		
	10	4.09	3.19	0.74	4.56	3.21	0.75	4.71	3.49	0.76	5.02	3.50	0.76	5.18	3.78	0.77	5.49	3.76	0.78	5.80	4.01	0.78		
	15	4.10	3.20	0.65	4.57	3.21	0.66	4.72	3.49	0.66	5.04	3.51	0.67	5.19	3.79	0.67	5.50	3.77	0.68	5.82	4.02	0.69		
	20	5.16	3.75	1.37	5.74	3.77	1.39	5.94	4.10	1.40	6.33	4.12	1.41	6.53	4.44	1.42	6.92	4.43	1.44	7.31	4.72	1.45		
	25	4.94	3.64	1.53	5.51	3.66	1.56	5.70	3.98	1.56	6.07	3.99	1.58	6.26	4.31	1.59	6.63	4.29	1.60	7.01	4.57	1.62		
	30	4.72	3.52	1.69	5.26	3.54	1.72	5.44	3.85	1.73	5.79	3.86	1.75	5.97	4.17	1.75	6.33	4.15	1.77	6.69	4.42	1.79		
	35	4.66	3.49	2.00	5.19	3.51	2.03	5.37	3.81	2.04	5.72	3.83	2.06	5.90	4.13	2.07	6.25	4.11	2.09	6.61	4.38	2.11		
40	3.59	2.94	1.43	4.00	2.95	1.45	4.13	3.21	1.46	4.40	3.22	1.47	4.54	3.48	1.48	4.81	3.47	1.49	5.09	3.69	1.51			
46	2.58	2.45	1.08	2.87	2.46	1.10	2.97	2.68	1.10	3.17	2.69	1.11	3.27	2.90	1.12	3.46	2.89	1.13	3.66	3.08	1.14			

MODEL : AU*A24L

AFR	15.5
-----	------

		Indoor temperature																						
		18			21			23			25			27			29			32				
		12			15			16			18			19			21			23				
Outdoor temperature	°CDB	TC	SHC	PI	TC	SHC	PI	TC	SHC	PI	TC	SHC	PI	TC	SHC	PI	TC	SHC	PI	TC	SHC	PI		
	-10	5.62	4.52	0.60	6.26	4.54	0.60	6.47	4.94	0.61	6.90	4.95	0.61	7.11	5.35	0.62	7.54	5.33	0.62	7.96	5.68	0.63		
	0	5.52	4.47	0.64	6.15	4.49	0.65	6.36	4.89	0.66	6.78	4.90	0.66	6.99	5.29	0.67	7.41	5.27	0.67	7.83	5.62	0.68		
	5	5.33	4.37	0.78	5.94	4.40	0.79	6.14	4.78	0.80	6.55	4.80	0.80	6.75	5.18	0.81	7.15	5.16	0.82	7.56	5.50	0.82		
	10	5.12	4.26	0.91	5.71	4.29	0.92	5.90	4.66	0.93	6.29	4.68	0.94	6.49	5.05	0.94	6.87	5.03	0.95	7.26	5.36	0.96		
	15	5.25	4.33	0.76	5.85	4.35	0.77	6.05	4.73	0.78	6.45	4.75	0.79	6.65	5.13	0.79	7.05	5.11	0.80	7.44	5.44	0.81		
	20	6.75	5.11	1.65	7.52	5.15	1.67	7.77	5.59	1.68	8.29	5.61	1.70	8.54	6.06	1.71	9.05	6.04	1.73	9.57	6.43	1.74		
	25	6.41	4.93	1.78	7.14	4.96	1.81	7.38	5.39	1.82	7.87	5.41	1.84	8.11	5.84	1.85	8.60	5.82	1.86	9.08	6.20	1.88		
	30	6.07	4.75	1.98	6.76	4.78	2.01	6.99	5.20	2.02	7.46	5.22	2.04	7.69	5.63	2.05	8.15	5.61	2.07	8.61	5.98	2.09		
	35	6.32	4.88	2.52	7.04	4.91	2.56	7.28	5.34	2.57	7.76	5.36	2.60	8.00	5.79	2.61	8.48	5.76	2.64	8.96	6.14	2.66		
40	5.22	4.31	2.10	5.81	4.34	2.14	6.01	4.72	2.15	6.41	4.73	2.17	6.61	5.11	2.18	7.00	5.09	2.20	7.40	5.42	2.22			
46	3.74	3.58	1.59	4.17	3.60	1.61	4.31	3.91	1.62	4.60	3.92	1.64	4.74	4.24	1.65	5.02	4.22	1.66	5.31	4.50	1.68			

AFR : Air flow rate (m³/min)
 TC : Total capacity (kW)
 SHC : Sensible Heat capacity (kW)
 PI : Power Input (kW)

6-2. HEATING CAPACITY

■ MODEL : AU*A18L

AFR	13.3
-----	------

		Indoor temperature										
		°CDB	16		18		20		22		24	
Outdoor temperature	°CDB	°CWB	TC	PI	TC	PI	TC	PI	TC	PI	TC	PI
	-15	-16	5.01	2.50	4.89	2.55	4.77	2.60	4.65	2.65	4.53	2.71
	-10	-11	5.76	2.61	5.62	2.67	5.49	2.72	5.35	2.77	5.21	2.83
	-5	-7	6.49	2.73	6.34	2.79	6.18	2.85	6.03	2.90	5.87	2.96
	0	-2	7.35	2.80	7.18	2.86	7.00	2.92	6.83	2.98	6.65	3.04
	5	3	8.04	2.79	7.85	2.84	7.66	2.90	7.47	2.96	7.28	3.02
	7	6	7.87	2.42	7.69	2.47	7.50	2.52	7.31	2.57	7.12	2.62
	10	8	8.12	2.43	7.92	2.48	7.73	2.53	7.54	2.58	7.34	2.63
	15	10	7.79	2.13	7.61	2.17	7.42	2.22	7.23	2.26	7.05	2.31
	20	15	7.17	1.64	7.00	1.67	6.83	1.71	6.66	1.74	6.49	1.77
24	18	7.39	1.65	7.21	1.68	7.03	1.71	6.86	1.75	6.68	1.78	

■ MODEL : AU*A24L

AFR	15.5
-----	------

		Indoor temperature										
		°CDB	16		18		20		22		24	
Outdoor temperature	°CDB	°CWB	TC	PI	TC	PI	TC	PI	TC	PI	TC	PI
	-15	-16	6.15	2.84	6.01	2.90	5.86	2.96	5.72	3.01	5.57	3.07
	-10	-11	6.92	3.03	6.75	3.09	6.59	3.15	6.42	3.22	6.26	3.28
	-5	-7	7.64	3.02	7.45	3.08	7.27	3.14	7.09	3.20	6.91	3.27
	0	-2	8.59	3.00	8.38	3.06	8.18	3.12	7.97	3.18	7.77	3.25
	5	3	9.54	3.02	9.31	3.08	9.09	3.14	8.86	3.20	8.63	3.27
	7	6	9.55	2.69	9.33	2.74	9.10	2.80	8.87	2.86	8.64	2.91
	10	8	9.87	2.69	9.63	2.75	9.40	2.80	9.16	2.86	8.93	2.92
	15	10	8.97	2.07	8.76	2.12	8.54	2.16	8.33	2.20	8.11	2.25
	20	15	8.23	1.63	8.03	1.66	7.84	1.69	7.64	1.73	7.45	1.76
24	18	8.52	1.62	8.32	1.66	8.12	1.69	7.92	1.73	7.71	1.76	

AFR: Air flow rate (m³/min)

TC : Total capacity (kW)

PI : Power Input (kW)

7. FAN PERFORMANCE

7-1. AIR VELOCITY DISTRIBUTION

■ MODEL : AU *A18L

● 4-WAY AIR OUTLET

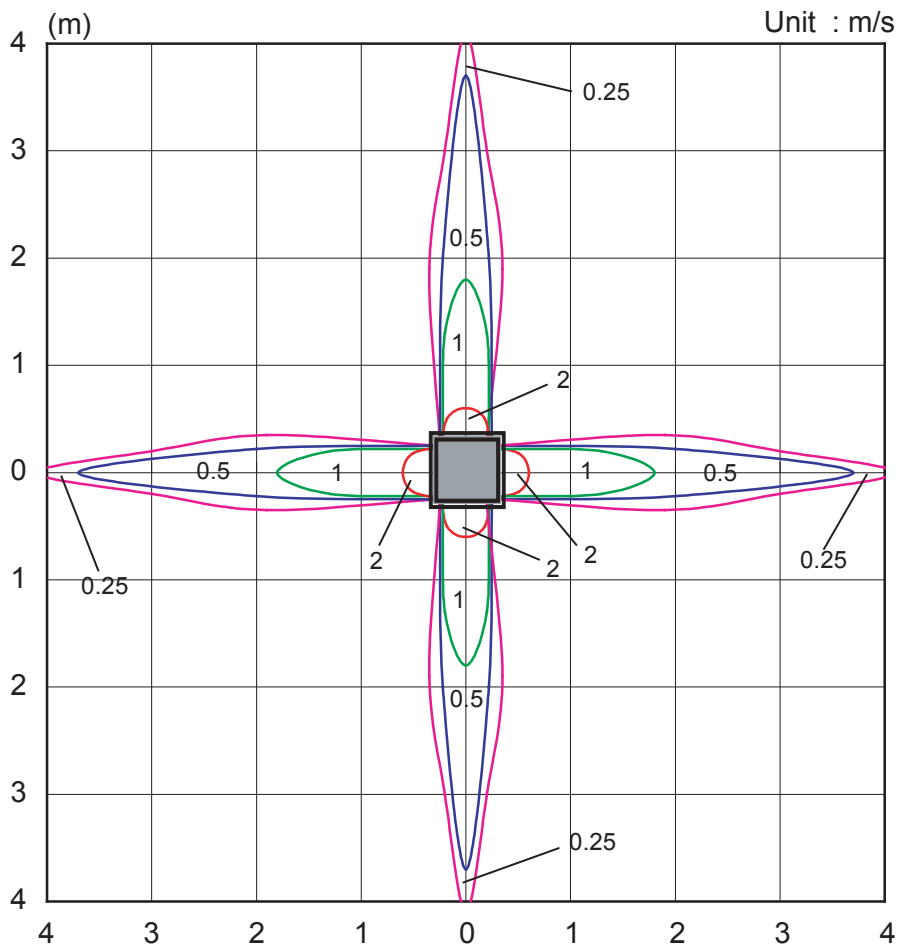

Note :
Condition
Fan speed : High
Operation mode : FAN
Ceiling mode : Standard

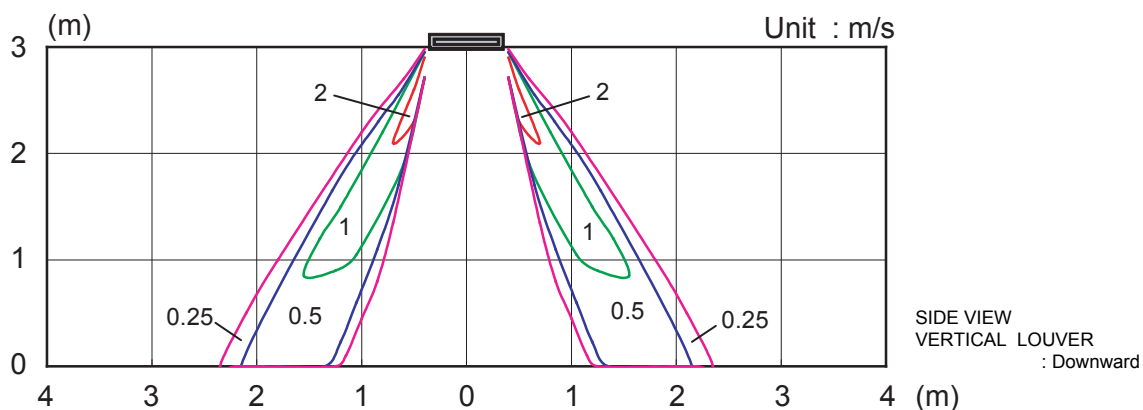
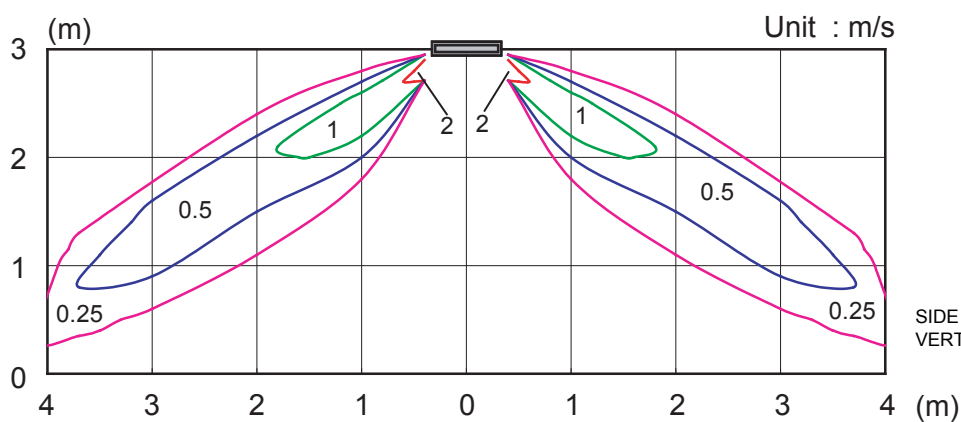

● 3-WAY AIR OUTLET

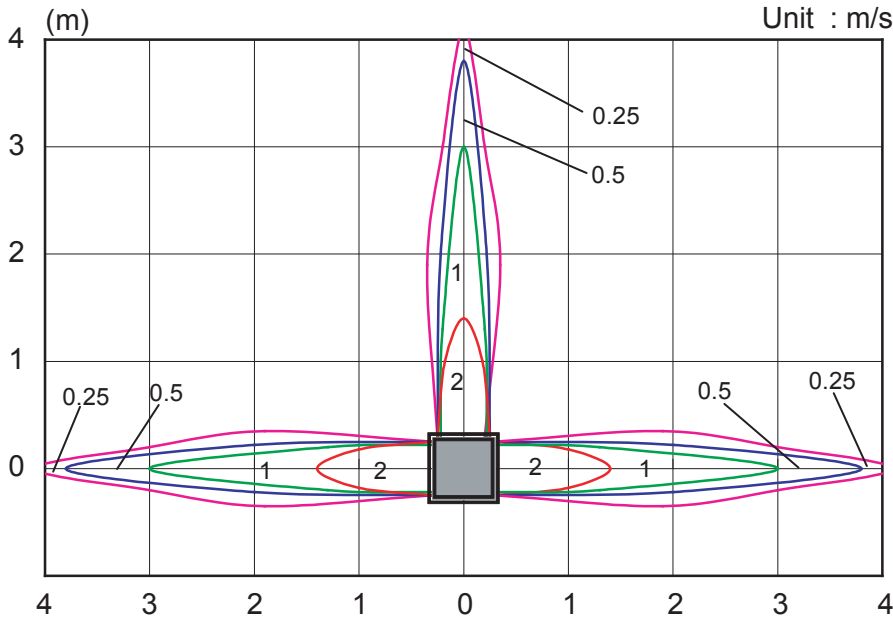

Note :
Condition
Fan speed : High
Operation mode : FAN
Ceiling mode : Standard

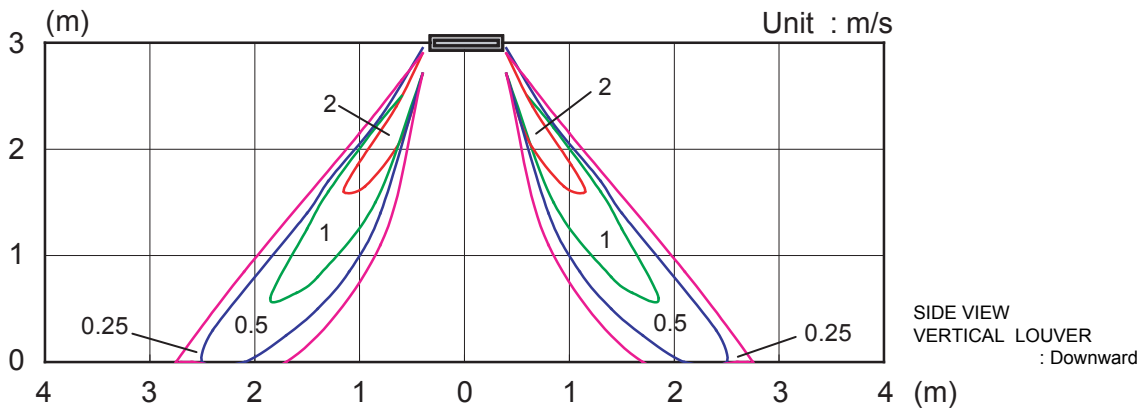
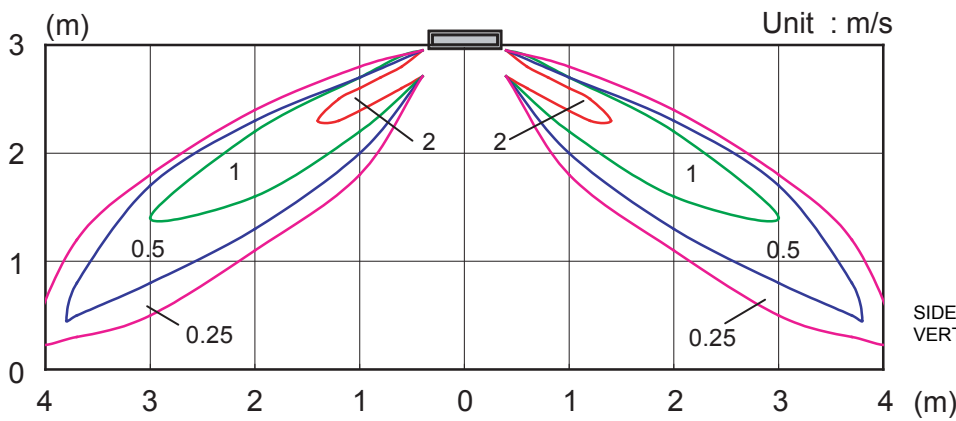

MODEL : AU *A24L

4-WAY AIR OUTLET

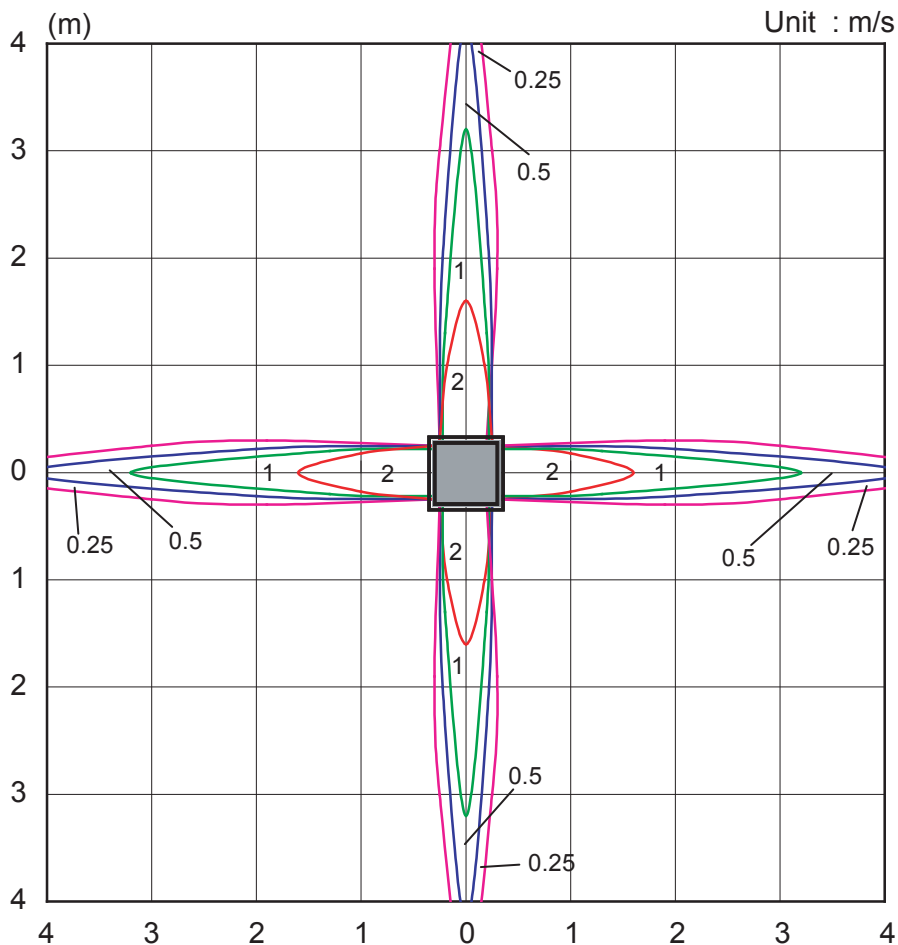

Note :
Condition
Fan speed : High
Operation mode : FAN
Ceiling mode : Standard

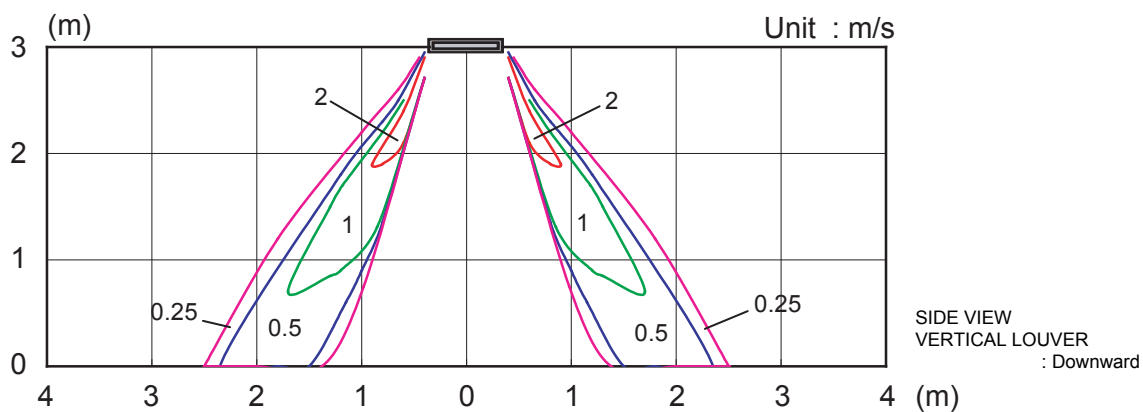
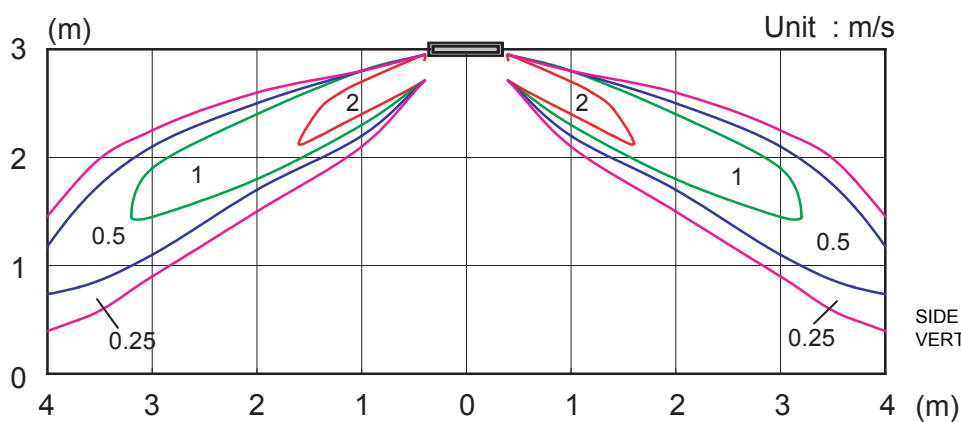

● 3-WAY AIR OUTLET

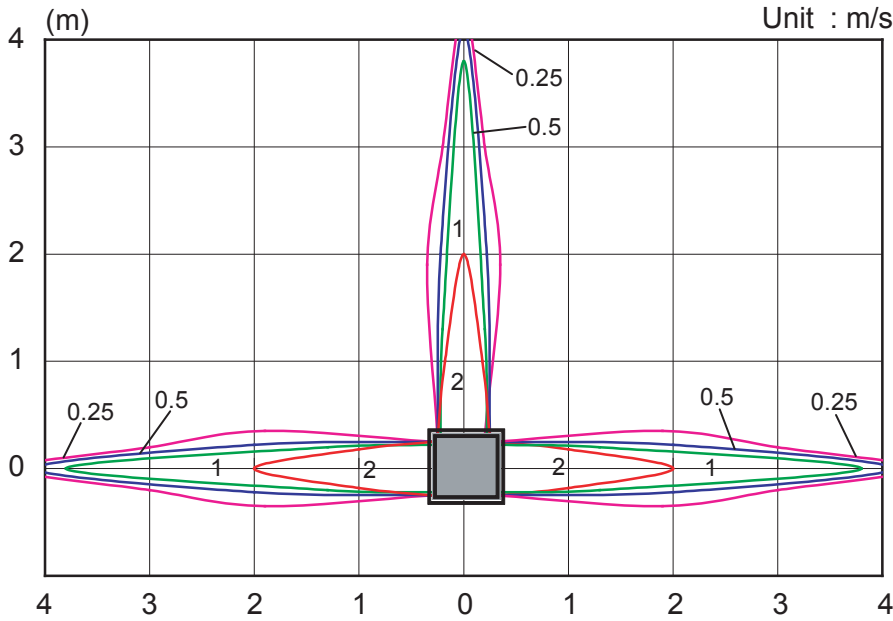

Note :
Condition
Fan speed : High
Operation mode : FAN
Ceiling mode : Standard

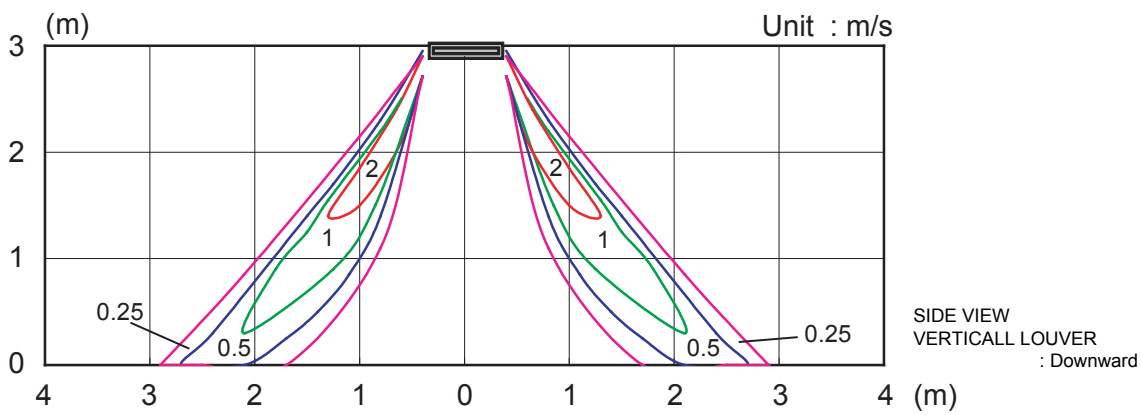
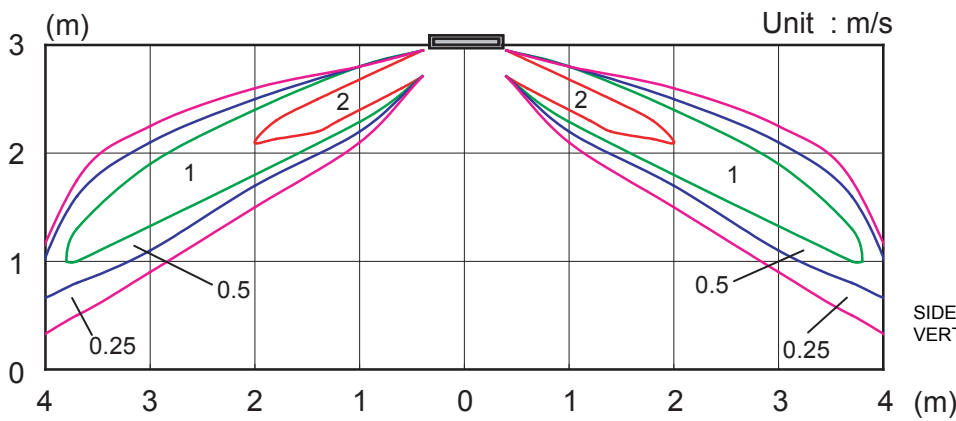

7-2. AIR FLOW

7-2-1. STANDARD CEILING MODE

■ MODEL : AU*A18L

● COOLING

FAN SPEED	NUMBER OF ROTATIONS (r.p.m)	AIR FLOW	
		m ³ /h	l/s
HIGH	730	m ³ /h	680
		l/s	189
		CFM	400
MED	630	m ³ /h	580
		l/s	161
		CFM	341
LOW	540	m ³ /h	490
		l/s	136
		CFM	288
QUIET	460	m ³ /h	410
		l/s	114
		CFM	241

● HEATING

FAN SPEED	NUMBER OF ROTATIONS (r.p.m)	AIR FLOW	
		m ³ /h	l/s
HIGH	830	m ³ /h	800
		l/s	222
		CFM	471
MED	730	m ³ /h	680
		l/s	189
		CFM	400
LOW	630	m ³ /h	580
		l/s	161
		CFM	341
QUIET	500	m ³ /h	450
		l/s	125
		CFM	265

■ MODEL : AU*A24L

● COOLING

FAN SPEED	NUMBER OF ROTATIONS (r.p.m)	AIR FLOW	
		m ³ /h	l/s
HIGH	960	m ³ /h	930
		l/s	258
		CFM	547
MED	850	m ³ /h	830
		l/s	231
		CFM	488
LOW	650	m ³ /h	600
		l/s	167
		CFM	353
QUIET	500	m ³ /h	450
		l/s	125
		CFM	265

● HEATING

FAN SPEED	NUMBER OF ROTATIONS (r.p.m)	AIR FLOW	
		m ³ /h	l/s
HIGH	960	m ³ /h	930
		l/s	258
		CFM	547
MED	880	m ³ /h	860
		l/s	239
		CFM	506
LOW	740	m ³ /h	700
		l/s	194
		CFM	412
QUIET	580	m ³ /h	530
		l/s	147
		CFM	312

7-2-2. HIGH CEILING MODE

■ MODEL : AU*A18L

● COOLING

FAN SPEED	NUMBER OF ROTATIONS (r.p.m)	AIR FLOW	
		m ³ /h	l/s
HIGH	830	800	222
		471	
MED	730	680	189
		400	
LOW	640	590	164
		347	
QUIET	460	410	114
		241	

● HEATING

FAN SPEED	NUMBER OF ROTATIONS (r.p.m)	AIR FLOW	
		m ³ /h	l/s
HIGH	930	900	250
		530	
MED	830	800	222
		471	
LOW	730	680	189
		400	
QUIET	500	450	125
		265	

■ MODEL : AU*A24L

● COOLING

FAN SPEED	NUMBER OF ROTATIONS (r.p.m)	AIR FLOW	
		m ³ /h	l/s
HIGH	1050	m ³ /h	1030
		l/s	286
		CFM	606
MED	950	m ³ /h	930
		l/s	258
		CFM	547
LOW	750	m ³ /h	710
		l/s	197
		CFM	418
QUIET	500	m ³ /h	450
		l/s	125
		CFM	265

● HEATING

FAN SPEED	NUMBER OF ROTATIONS (r.p.m)	AIR FLOW	
		m ³ /h	l/s
HIGH	1030	m ³ /h	1000
		l/s	278
		CFM	589
MED	980	m ³ /h	960
		l/s	267
		CFM	565
LOW	840	m ³ /h	820
		l/s	228
		CFM	483
QUIET	580	m ³ /h	530
		l/s	147
		CFM	312

8. OPERATION NOISE

8-1. NOISE LEVEL CURVE

Condition
Ceiling mode : Standard
Air outlet : 4-way air outlet

COOLING

● MODEL : AU*A18L

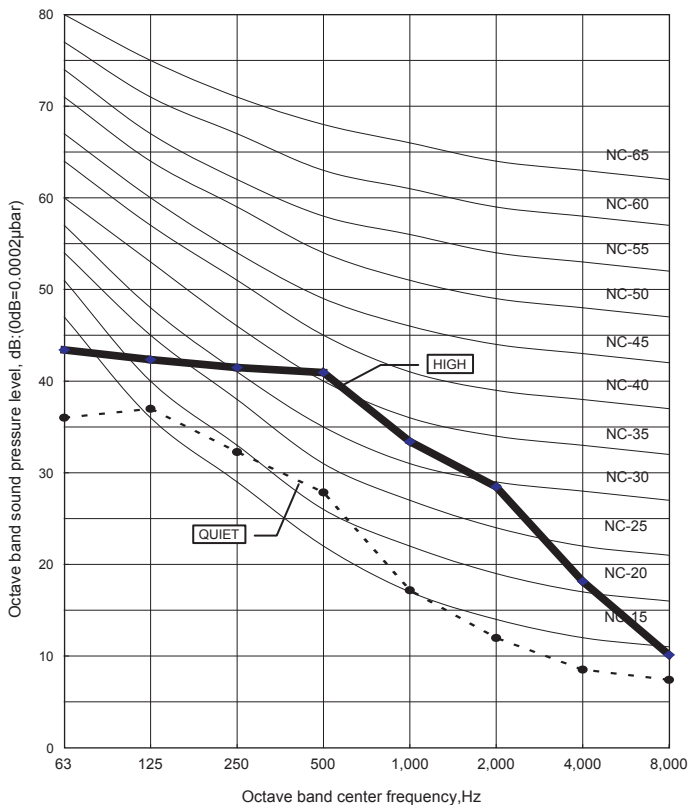

● MODEL : AU*A24L

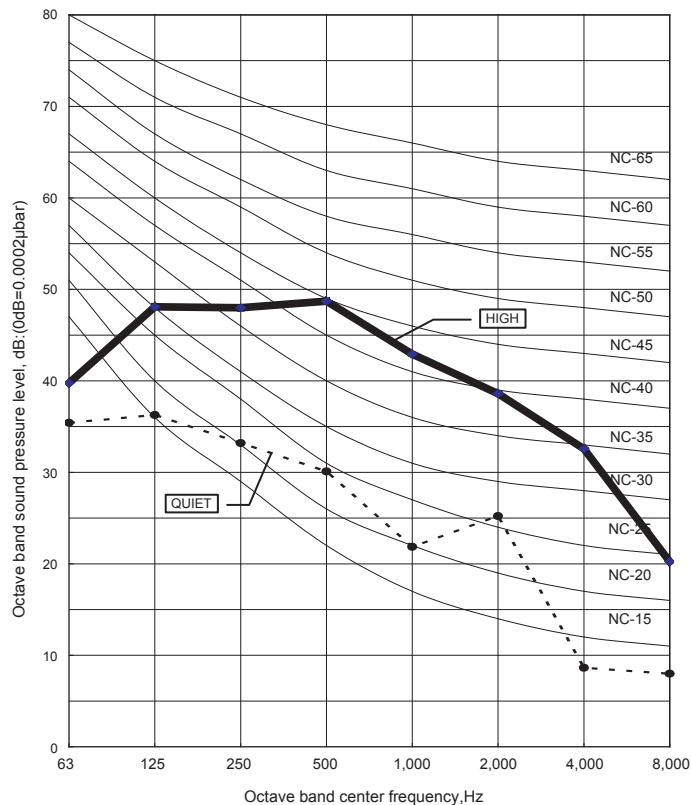

HEATING

● MODEL : AU*A18L

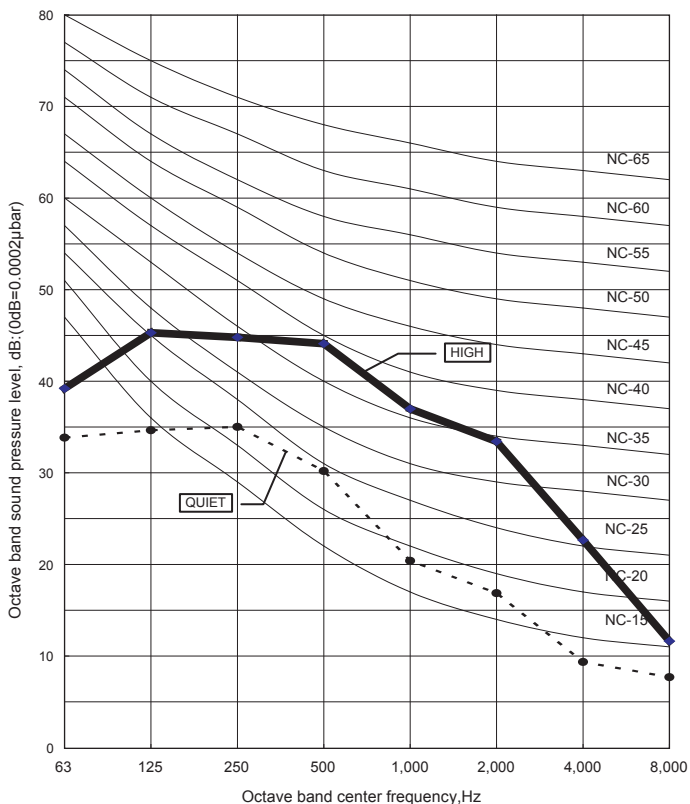

● MODEL : AU*A24L

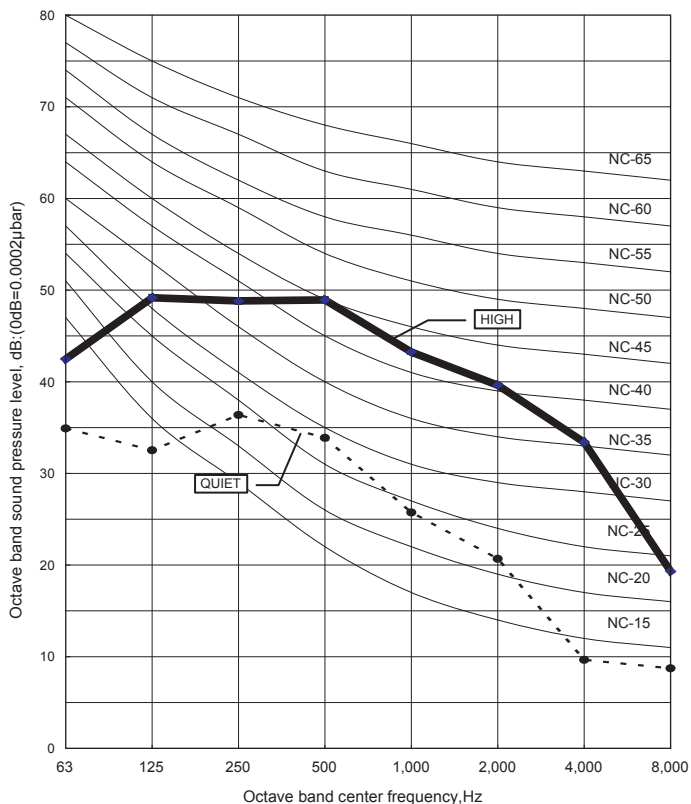

8-2. SOUND LEVEL CHECK POINT

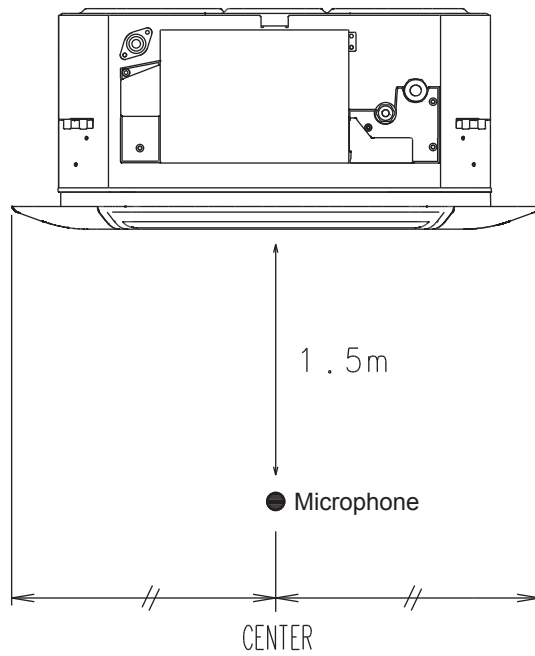
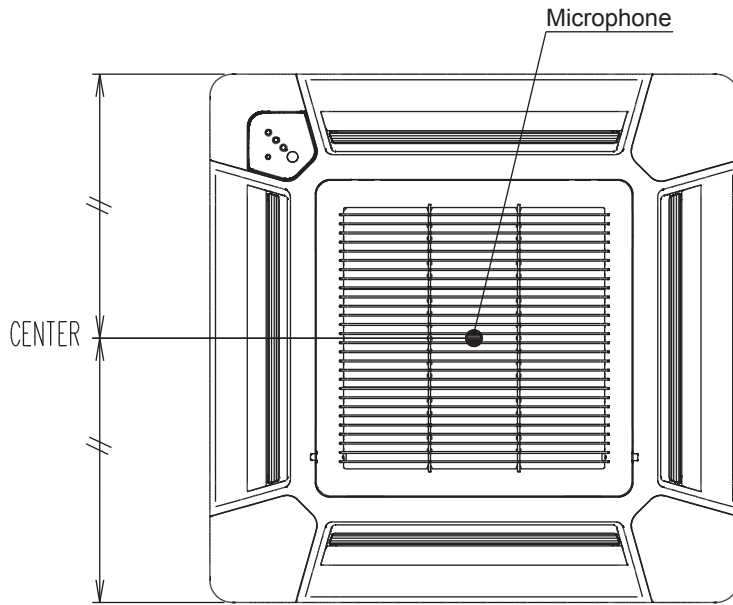

9. ELECTRIC CHARACTERISTICS

Model Name			AU * A18L	AU * A24L
Power Supply	Voltage	V	230 ~	
	Frequency	Hz	50	
Max Operating Current		A	0.2	0.3
*1)Wiring Spec.	Circuit breaker	A	0.3	0.4
	Connection Cable	mm ²	1.5-2.5	1.5-2.5
	Limited wiring length	m	26	31

*1) Wiring Spec.



Selected Sample

(Selected based on Japan Electrotechnical Standard and Codes Committee E0005)

10. SAFETY DEVICE

	Protection form	Model	
		AU * A18L	AU * A24L
Circuit protection	Current fuse (PCB)	3.15A 250V	
Fan motor protection	Thermal protection program	140±20°C OFF 110±20°C ON	

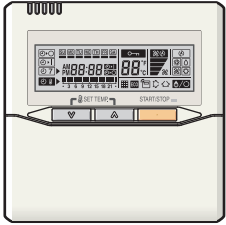
11. OPTIONAL PARTS

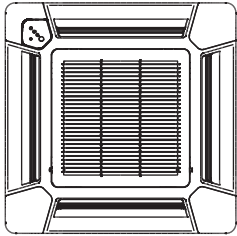
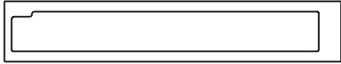
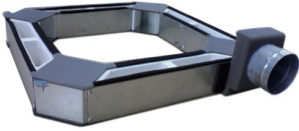
Exterior	Parts name	Model No.	Summary
	Wired remote controller	UTB-*UD	Unit control is performed by wired remote controller
	Wireless remote controller	UTB-*NA	Unit control is performed by wireless remote controller
	Decoration panel	UTG-UF*A-F	Ceiling dirt by discharged wind was made difficult to cling by reviewing the shape of the LOUVER.
	Air outlet shutter plate	UTR-YDZA	Air outlet shutter plate is installed at the air outlet when 3-way direction is performed.
	Fresh air intake kit	UTZ-VXAA	It can be taken in fresh air of up to 10% of "high" air volume of the indoor unit by attaching Fresh Air Intake Kit to cassette type indoor unit.

OUTDOOR UNIT

2. SINGLE TYPE :

AO * A18LACL

AO * A18LALL

AO * A24LACL

AO * A24LALL

1. SPECIFICATIONS

OUTDOOR UNIT
AO*A18-24L

OUTDOOR UNIT
AO*A18-24L

Type			INVERTER HEATPUMP			
Model name			AO * A18LACL AO * A18LALL	AO * A24LACL AO * A24LALL		
Power source			230V~ 50Hz			
Available voltage range			198-264V~ 50Hz			
Starting current		A	7.7	10.0		
Fan	Airflow rate	Cooling	2000	2470		
		Heating	1910	2470		
	Type × Q'ty		Propeller × 1			
	Motor output		W	54	65	
Sound pressure level		Cooling	50	52		
		Heating	50	53		
Heat exchanger type		Dimensions (H × W × D)	mm	546 × 876 × 18.2	546 × 866 × 18.2	
				546 × 842 × 18.2	546 × 832 × 18.2	
		Fin pitch		1.30	1.40	
		Rows x Stages		2 × 26	2 × 26 1 × 24	
		Pipe type		Copper		
Fin type		Aluminium				
Compressor		Type × Q'ty		Twin Rotary × 1		
		Motor output		W	1100	
Refrigerant		Type		R410A		
		Charge		g	1250	1700
Refrigerant oil		Type		POE		
Enclosure		Material		Steel sheet		
		Colour		Beige (10YR7.5/1.0NN)		
Dimensions (H × W × D)		Net		578 × 790 × 300	578 × 790 × 315	
		Gross		648 × 910 × 380		
Weight		Net		40 (88)	44 (97)	
		Gross		44 (97)	48 (106)	
Connection pipe		Size	Liquid	Φ 6.35 (Φ 1/4 in.)		
			Gas	Φ 12.70 (Φ 1/2 in.)	Φ 15.88(Φ 5/8 in.)	
		Method		Flare		
		Max. length		m	25(chargeless : 15)	30(chargeless : 15)
		Max. height difference			15	20
Operation range		Cooling	-10 to 46			
		Heating	-15 to 24			

Note :

Specifications are based on the following conditions.

Cooling : Indoor temperature of 27°CDB/19°CWB. and outdoor temperature of 35°CDB/24°CWB.

Heating : Indoor temperature of 20°CDB/15°CWB. and outdoor temperature of 7°CDB/6°CWB.

Pipe length : 7.5 m, Height difference : 0 m. (Outdoor unit - Indoor unit)

2. DIMENSIONS

MODELS : AO*A18L, AO*A24L

(Unit : mm)

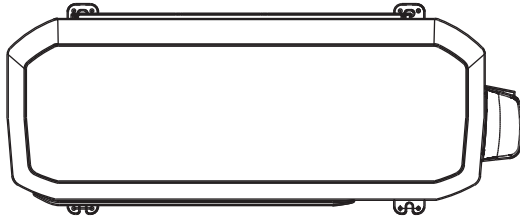

Top view

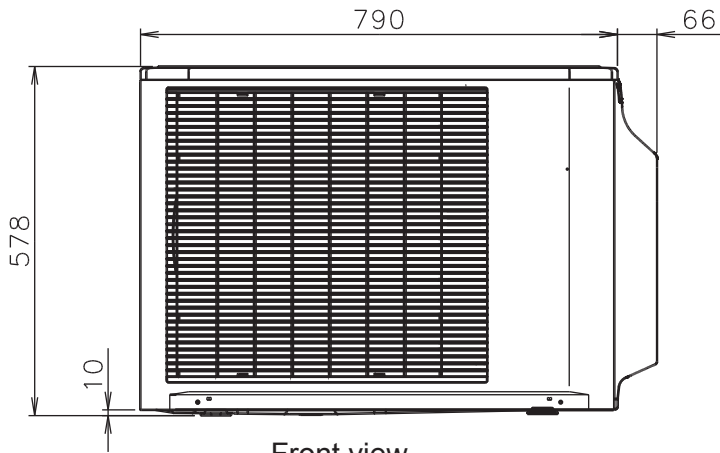

Front view

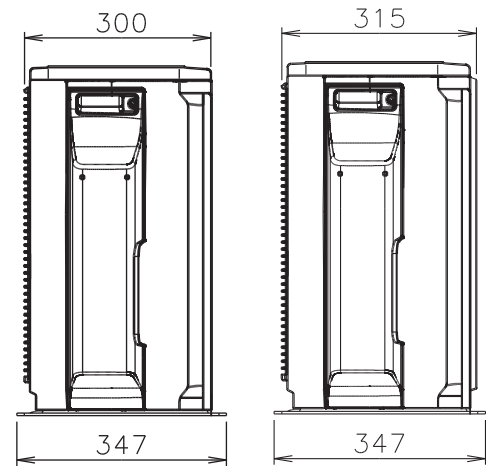

AO*A18L

AO*A24L

Side view

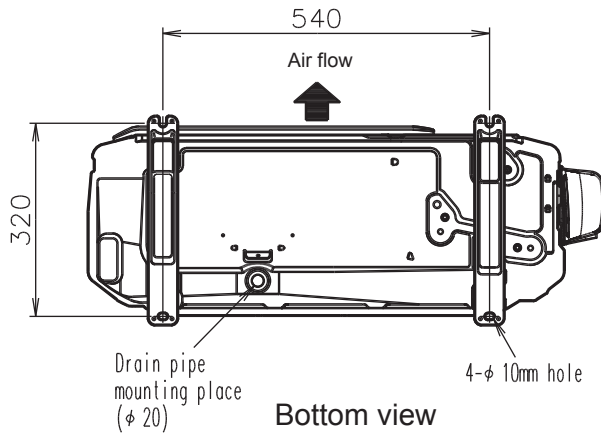

Bottom view

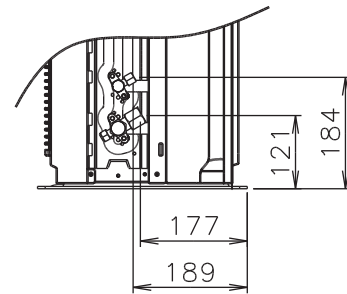

MOUNTING POSITION

When there are obstacles at the back or front sides.

When there are obstacles at the back, side(s), and top.

When there are obstacles at the back, side with the installation of more than one unit.

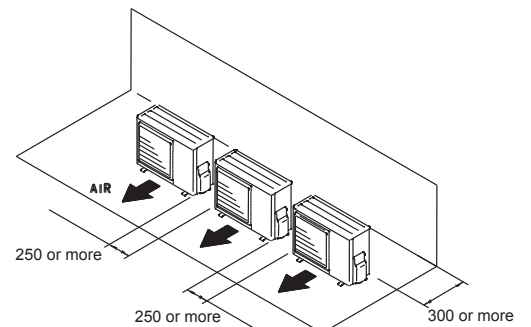
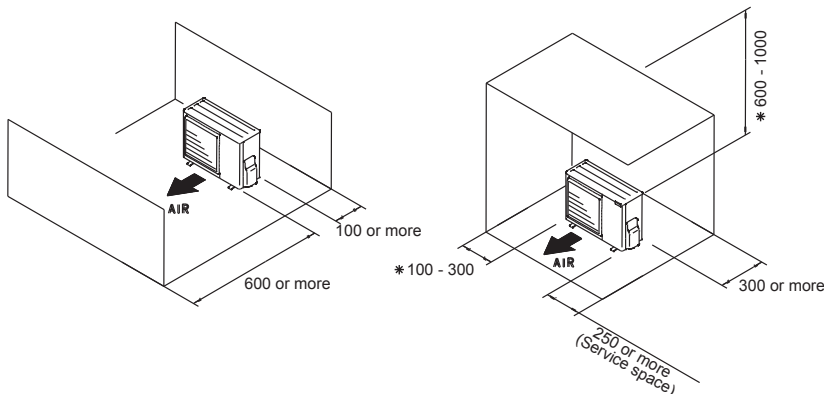

* If the space is larger than that is stated, the condition will be the same as that are no obstacles.

3. REFRIGERANT CIRCUIT

OUTDOOR UNIT
AO*A18-24L

OUTDOOR UNIT
AO*A18-24L

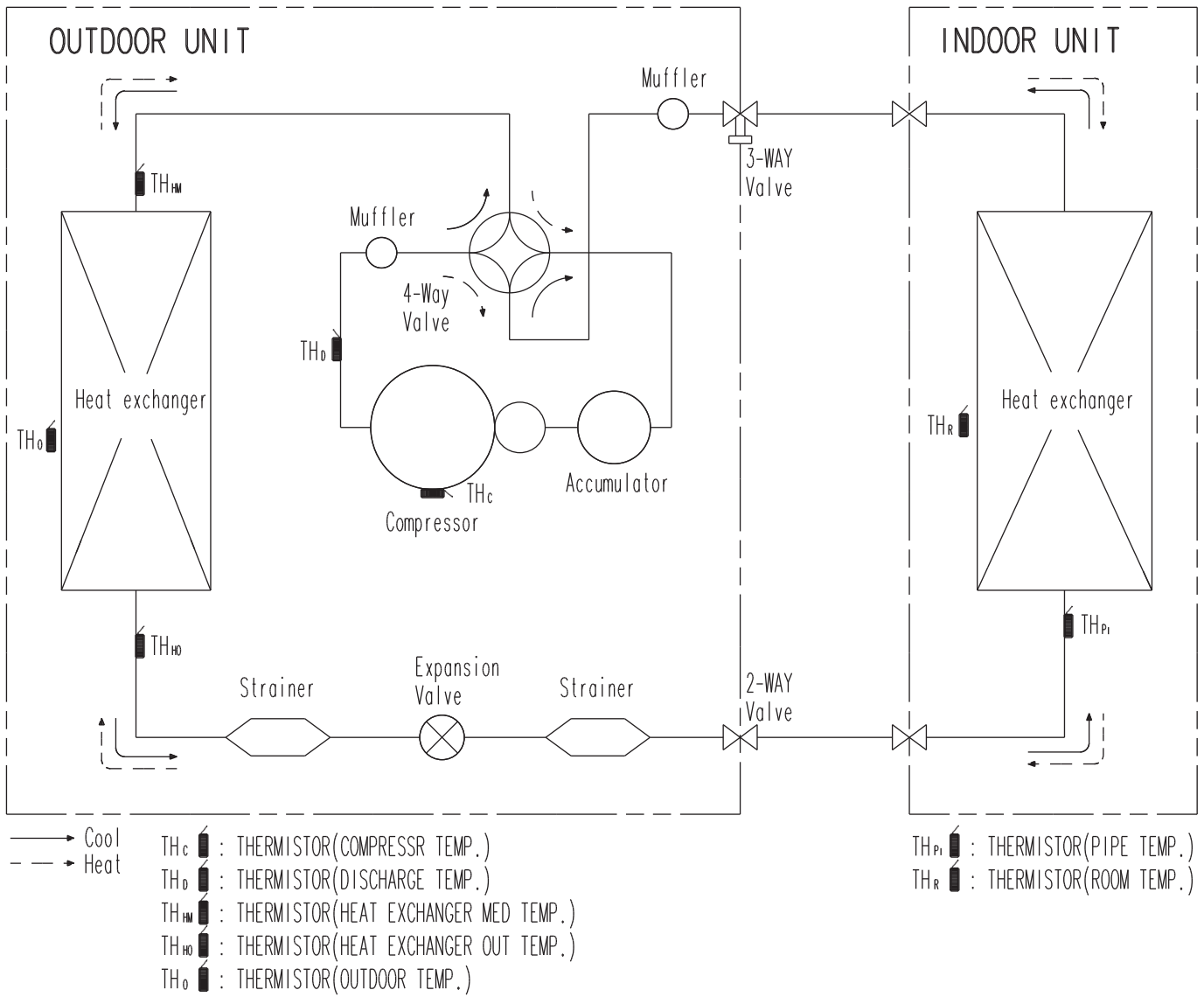

4. WIRING DIAGRAMS

■ MODELS : AO*A18L, AO*A24L

OUTDOOR UNIT
AO*A18-24L

OUTDOOR UNIT
AO*A18-24L

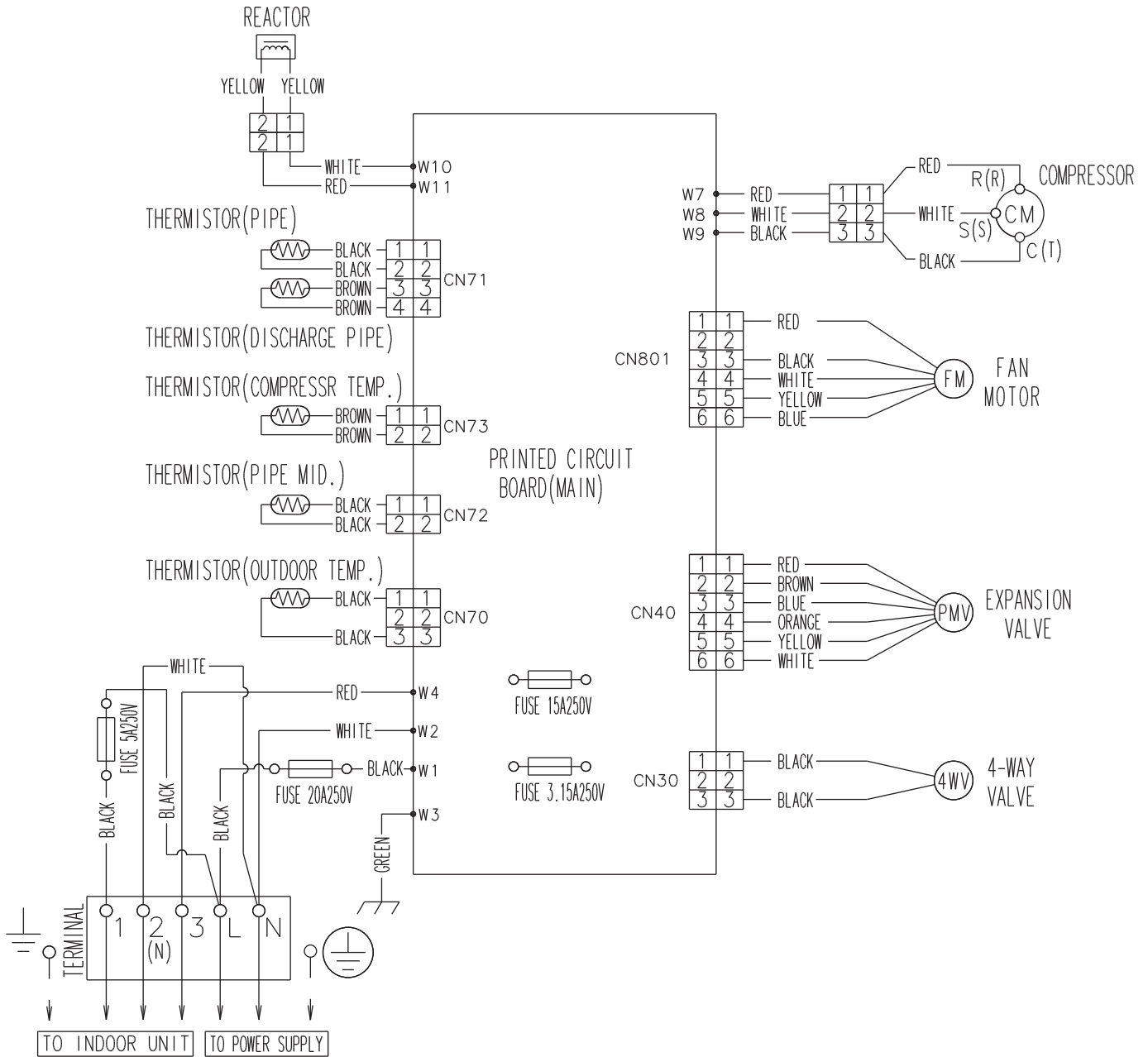

5. CAPACITY COMPENSATION RATE FOR PIPE LENGTH AND HEIGHT DIFFERENCE

MODEL : AO*A18L

OUTDOOR UNIT
AO*A18-24L

OUTDOOR UNIT
AO*A18-24L

COOLING			Pipe length (m)					
			5	7.5	10	15	20	25
Height difference H (m)	* 1 Indoor unit is upper than outdoor unit.	15	-	-	-	0.953	0.950	0.947
		10	-	-	0.983	0.968	0.966	0.962
		7.5	-	0.988	0.987	0.972	0.970	0.966
		5	0.992	0.992	0.991	0.976	0.974	0.970
	* 2 Indoor unit is under than outdoor unit	0	1.000	1.000	0.999	0.984	0.982	0.978
		-5	1.000	1.000	0.999	0.984	0.982	0.978
		-7.5	-	1.000	0.999	0.984	0.982	0.978
		-10	-	-	0.999	0.984	0.982	0.978
	-15	-	-	-	0.984	0.982	0.978	

HEATING			Pipe length (m)					
			5	7.5	10	15	20	25
Height difference H (m)	* 1 Indoor unit is upper than outdoor unit.	15	-	-	-	0.920	0.894	0.867
		10	-	-	0.982	0.920	0.894	0.867
		7.5	-	1.000	0.982	0.920	0.894	0.867
		5	0.993	1.000	0.982	0.920	0.894	0.867
	* 2 Indoor unit is under than outdoor unit	0	0.993	1.000	0.982	0.920	0.894	0.867
		-5	0.988	0.995	0.977	0.916	0.889	0.862
		-7.5	-	0.993	0.975	0.913	0.887	0.860
		-10	-	-	0.972	0.911	0.885	0.858
	-15	-	-	-	0.902	0.876	0.849	

Height difference H

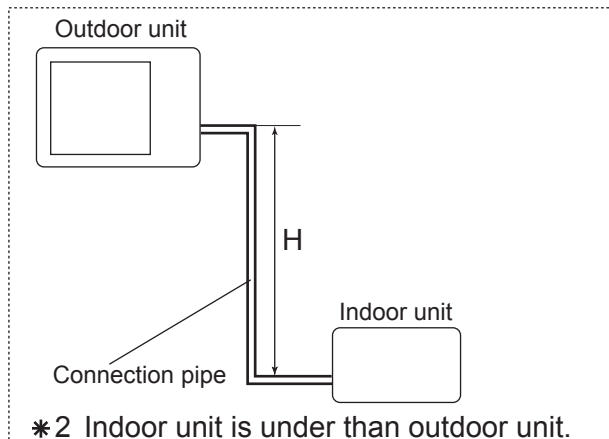
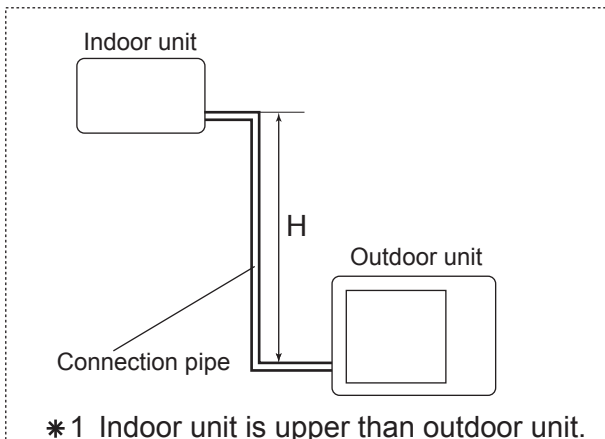

MODEL : AO*A24L

OUTDOOR UNIT
AO*A18-24L

OUTDOOR UNIT
AO*A18-24L

COOLING			Pipe length (m)						
			5	7.5	10	15	20	25	30
Height difference H (m)	* 1 Indoor unit is upper than outdoor unit.	20	-	-	-	-	0.963	0.961	0.959
		10	-	-	0.984	0.981	0.979	0.977	0.975
		7.5	-	0.988	0.988	0.985	0.983	0.981	0.979
		5	0.992	0.992	0.992	0.989	0.987	0.985	0.983
		0	1.000	1.000	1.000	0.997	0.995	0.993	0.991
	* 2 Indoor unit is under than outdoor unit	-5	1.000	1.000	1.000	0.997	0.995	0.993	0.991
		-7.5	-	1.000	1.000	0.997	0.995	0.993	0.991
		-10	-	-	1.000	0.997	0.995	0.993	0.991
-20		-	-	-	-	0.995	0.993	0.991	

HEATING			Pipe length (m)						
			5	7.5	10	15	20	25	30
Height difference H (m)	* 1 Indoor unit is upper than outdoor unit.	20	-	-	-	-	0.927	0.893	0.863
		10	-	-	0.992	0.952	0.927	0.893	0.863
		7.5	-	1.000	0.992	0.952	0.927	0.893	0.863
		5	1.001	1.000	0.992	0.952	0.927	0.893	0.863
		0	1.001	1.000	0.992	0.952	0.927	0.893	0.863
	* 2 Indoor unit is under than outdoor unit	-5	0.996	0.995	0.987	0.947	0.922	0.888	0.859
		-7.5	-	0.993	0.984	0.945	0.920	0.886	0.857
		-10	-	-	0.982	0.943	0.917	0.884	0.855
-20		-	-	-	-	0.908	0.875	0.846	

Height difference H

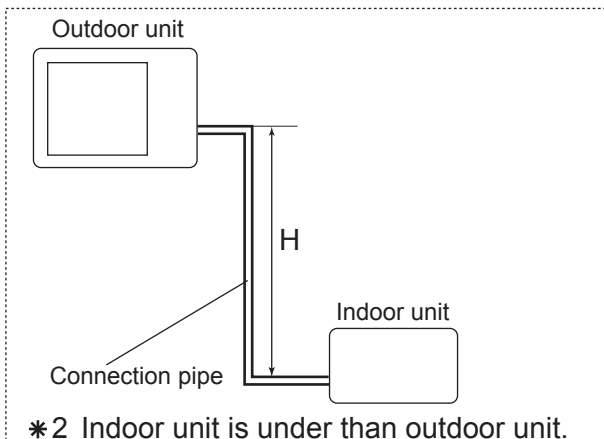
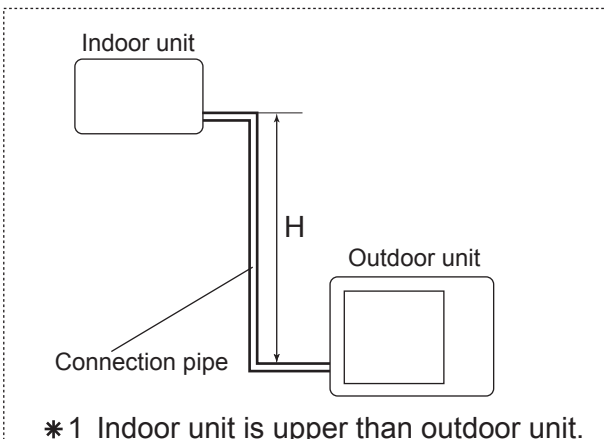

6. ADDITIONAL CHARGE CALCULATION

■ MODEL : AO*A18L

Refrigerant type		R410A
Refrigerant amount	g	1250

● REFRIGERANT CHARGE

Pipe length	m	~ 15	20	25	20g/m
Additional charge	g	0 (Chargeless)	+100	+200	

■ MODEL : AO*A24L

Refrigerant type		R410A
Refrigerant amount	g	1700

● REFRIGERANT CHARGE

Pipe length	m	~ 15	20	25	30	20g/m
Additional charge	g	0 (Chargeless)	+100	+200	+300	

7. AIR FLOW

■ MODEL : AO*A18L

● COOLING

NUMBER OF ROTATIONS (r.p.m)	Airflow	
	860	m ³ /h
l/s		556
CFM		1177

● HEATING

NUMBER OF ROTATIONS (r.p.m)	Airflow	
	820	m ³ /h
l/s		531
CFM		1124

■ MODEL : AO*A24L

● COOLING

NUMBER OF ROTATIONS (r.p.m)	Airflow	
	1050	m ³ /h
l/s		686
CFM		1454

● HEATING

NUMBER OF ROTATIONS (r.p.m)	Airflow	
	1050	m ³ /h
l/s		686
CFM		1454

8. OPERATION NOISE

8-1. NOISE LEVEL CURVE

■ COOLING

● MODEL : AO*A18L

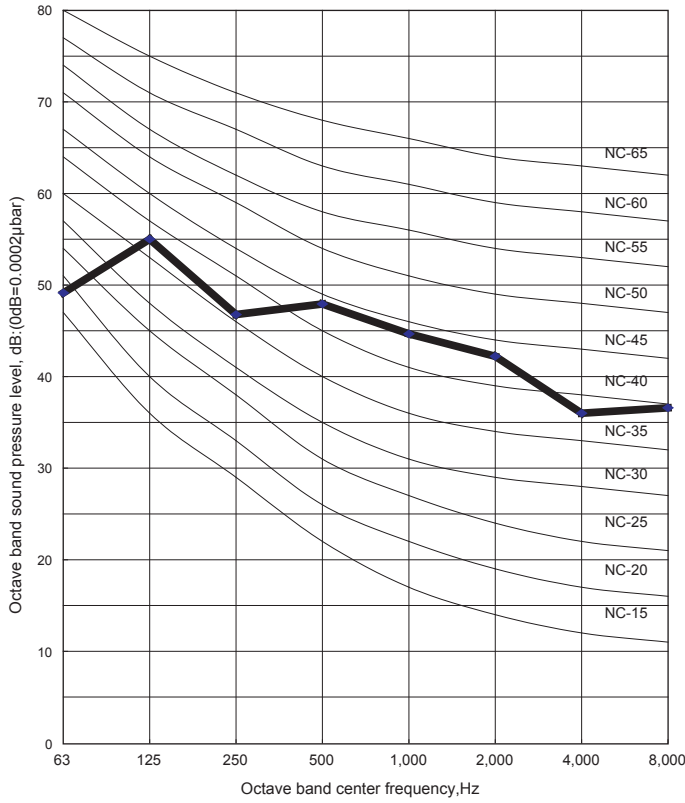

● MODEL : AO*A24L

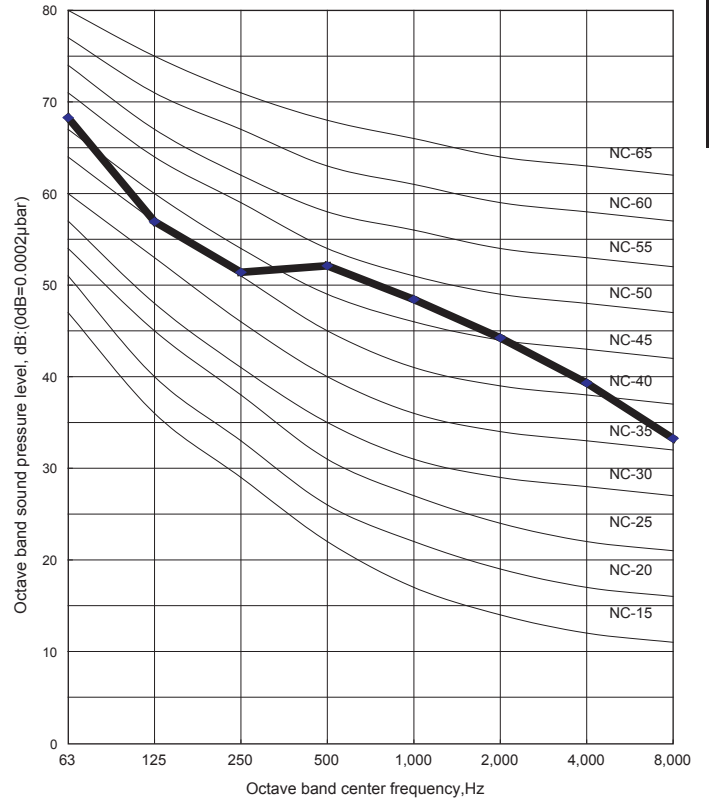

■ HEATING

● MODEL : AO*A18L

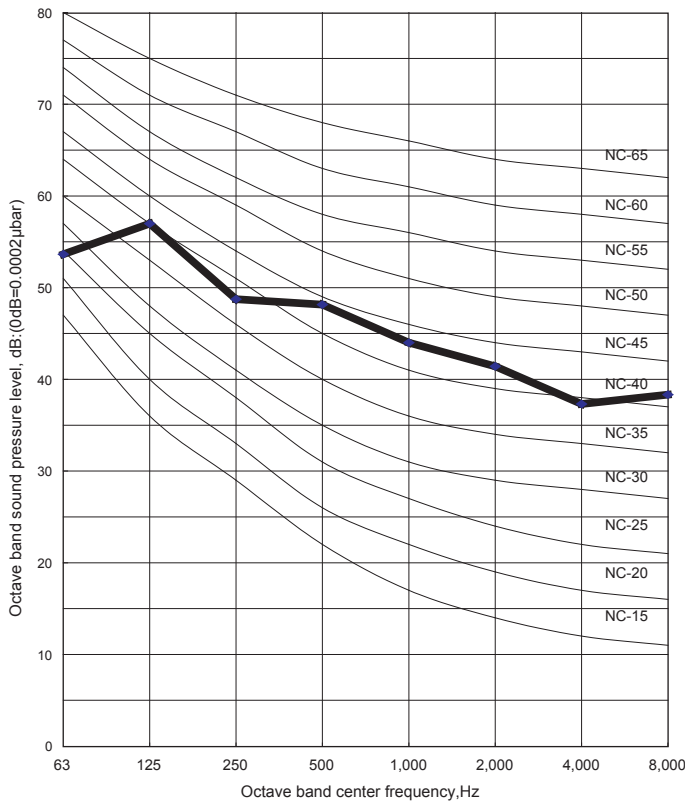

● MODEL : AO*A24L

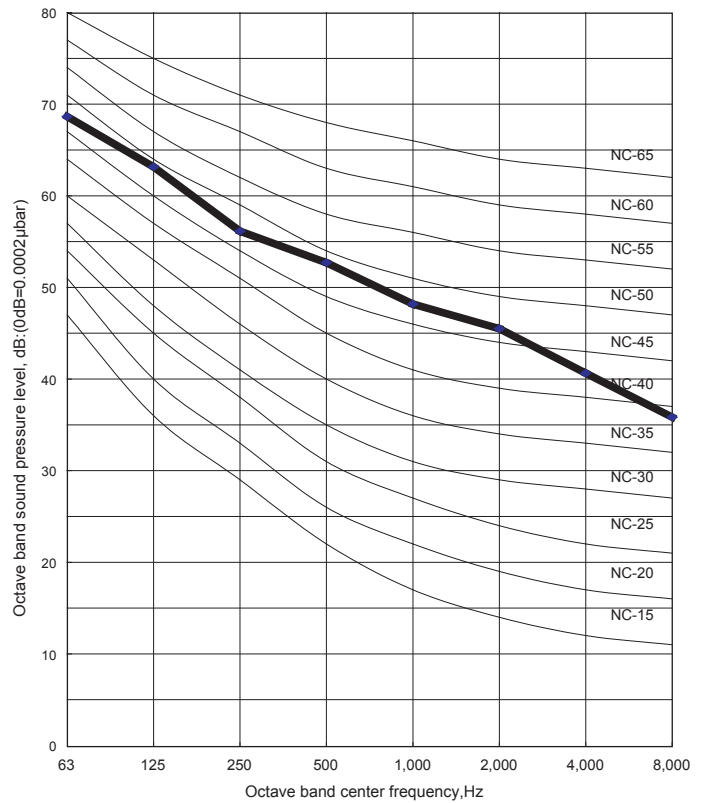

OUTDOOR UNIT
AO*A18-24L

OUTDOOR UNIT
AO*A18-24L

8-2. SOUND LEVEL CHECK POINT

OUTDOOR UNIT
AO*A18-24L

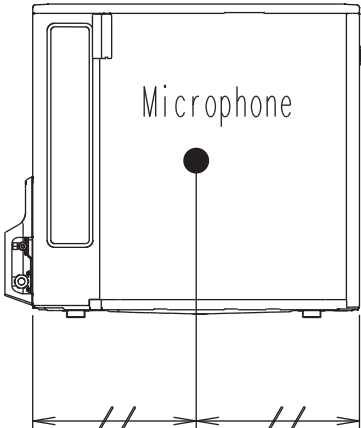
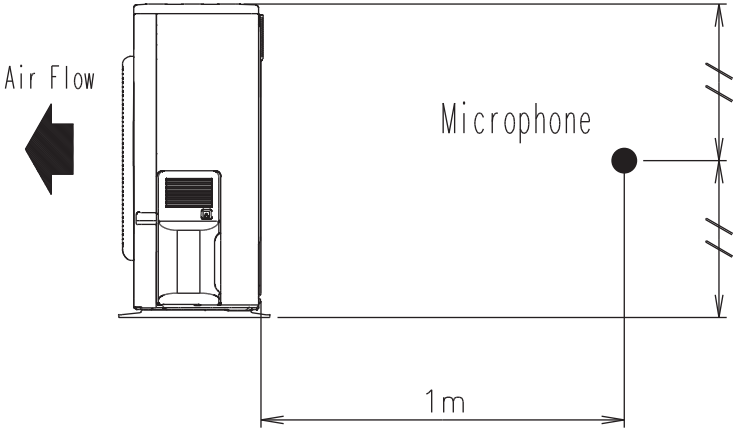

OUTDOOR UNIT
AO*A18-24L

9. ELECTRIC CHARACTERISTICS

Model Name			AO * A18L	AO * A24L
Power Supply	Voltage	V	230~	
	Frequency	Hz	50	
Max Operating Current		A	15.0	16.2
Starting Current		A	7.7	10.0
*1) Wiring Spec.	Main Fuse (Circuit breaker) Current	A	20	20
	Power Cable	mm ²	3.5 - 4.5	
	*2)Limited wiring length	m	24	22

*1) Wiring Spec.

Selected Sample

(Selected based on Japan Electrotechnical Standard and Codes Committee E0005)

*2) Limited Wiring length :

This is the wiring length in case voltage descent is less than 2%.

When the wiring length becomes long, please select the wiring of a more larger diameter.

10. SAFETY DEVICES

OUTDOOR UNIT
AO*A18-24L

OUTDOOR UNIT
AO*A18-24L

	Protection form	Model	
		AO * A18L	AO * A24L
Circuit protection	Current fuse (NEAR THE TERMINAL)	20A 250V	
		5A 250V	
	Current fuse (MAIN PRINTED CIRCUIT BOARD)	15A 250V	
		3.15A 250V	
Fan motor protection	Thermal protection program	OFF:100 ⁺¹⁵ ₋₁₀ °C ON:95 ⁺¹⁵ ₋₁₀ °C	OFF:110 ⁺¹⁵ ₋₁₀ °C ON:105 ⁺¹⁵ ₋₁₀ °C
Compressor protection	Thermal protection program (COMPRESSOR TEMP.)	OFF:110°C ON: After 40 minutes	
	Thermal protection program (DISCHARGE TEMP.)	OFF:110°C ON: After 7 minutes	

REMOTE CONTROLLER

3. WIRED REMOTE CONTROLLER : UTB - *UD

FEATURES

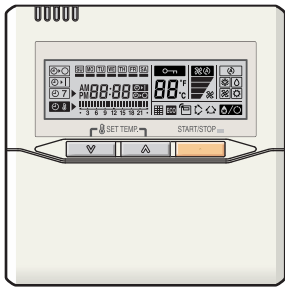

- * Various timer setup (ON / OFF / WEEKLY) are possible.
- * Equipped with weekly timer as standard function. (2 times Start / Stop per day for a week)
- * When setting up a timer, operation mode and a temperature setup can be changed.
- * When a failure occurs, the error code is displayed. (Maximum of 16)
- * Error indication. (A maximum of 16 error histories are memorizable.)
- * Up to 16 indoor units can be simultaneously controlled.
- * Economy operation are possible.
- * Easy installation with a slim shape with no bulge in the back.
- * The room temperature can be controlled by being detected the temperature accurately with built-in thermo sensor.

REMOTE CONTROLLER
UTB-*/UD

REMOTE CONTROLLER
UTB-*/UD

Simple function setting

Setting of the air conditioner selection function is performed by remote controller.

High performance and compact size

Three functions are combined in one unit.



Built-in timers

Weekly timer

Possible to set ON/OFF time to operate twice each day of the week.

Easy-to-understand time bar display

Screen after setup

Setup screen example
(Set to Wednesday: 8:00 to 20:00.)

Setback timer

Possible to set temperature for two time spans and for each day of the week.

Setup screen example
(Set from Sunday to Saturday: 12:00 to 15:00, 28 °C.)

At "Weekly timer" + "Set back timer" setup

24°C → 28°C → 24°C

Easy-to-understand operation

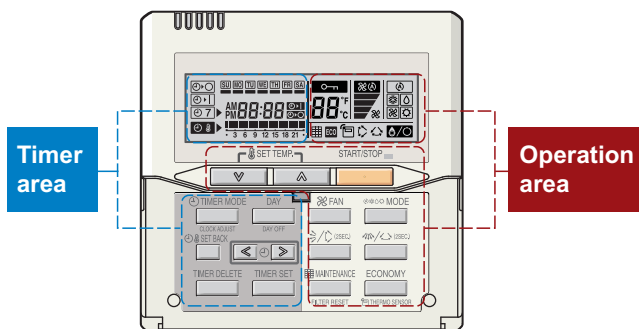

[Variable timer control]
The operation/display sections are zoned according to time and operation, enabling variable programming to match application.

Simple installation

Components are compatible with standard switch boxes. Flat back construction allows equipment to be installed wherever it is needed.

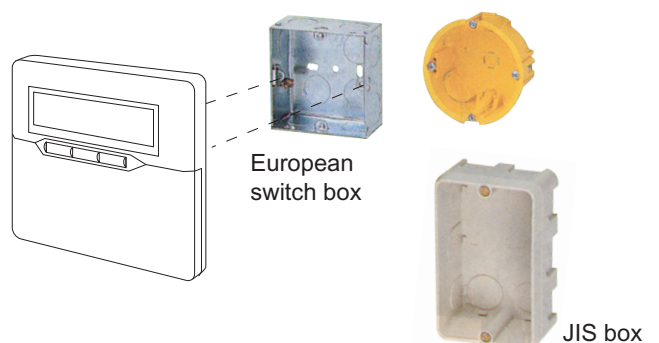

FUNCTIONS

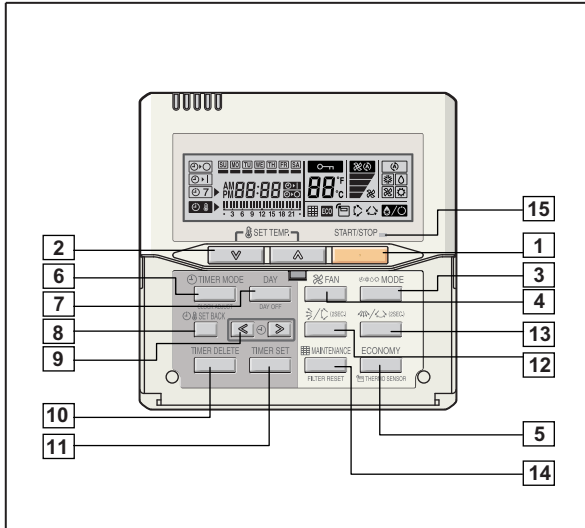

Display panel

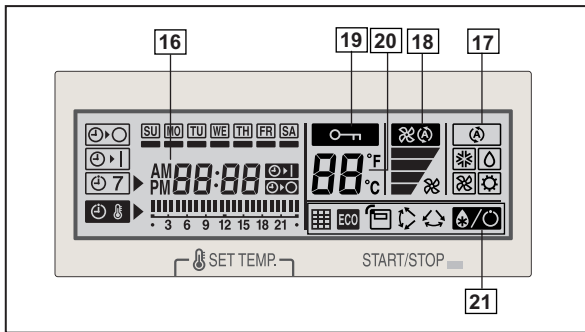

- 1 **START/STOP button**
Pressed to start and stop operation.
- 2 **Set temperature button**
Selects the setting temperature.
- 3 **Master control button**
Selects the operating mode(AUTO, HEAT, FAN, COOL, DRY).
- 4 **Fan control button**
Selects the fan speed (AUTO, QUIET, LOW, MED, HIGH).
- 5 **Economy button**
Turns the economy efficient mode on and off.
- 6 **Timer mode (CLOCK ADJUST) button**
Selects the timer mode (OFF TIMER, ON TIMER, WEEKLY TIMER)
Set the current time.
- 7 **Day (DAY OFF) button**
Temporarily cancels of one day timer.
- 8 **Set back button**
Pressed to select the set back timer.
- 9 **Set time button**
Pressed to set time.
- 10 **Delete button**
The schedule of a weekly timer is deleted.
- 11 **Set button**
Sets the date, hour, minute and on-off time.
- 12 **Vertical airflow direction and swing button**
Push for two seconds to change the swing mode.
- 13 **Horizontal airflow direction and swing button**
Push for two seconds to change the swing mode.
- 14 **Filter button**
- 15 **Operation lamp**
Lights during operation and when the timer is on.
- 16 **Timer and clock display**
- 17 **Operation mode display**
- 18 **Fan speed display**
- 19 **Operation lock display**
- 20 **Temperature display**
- 21 **Function display**
 - Defrost display
 - Thermo sensor display
 - Economy display
 - Vertical swing display
 - Horizontal swing display
 - Filter display

DIMENSION

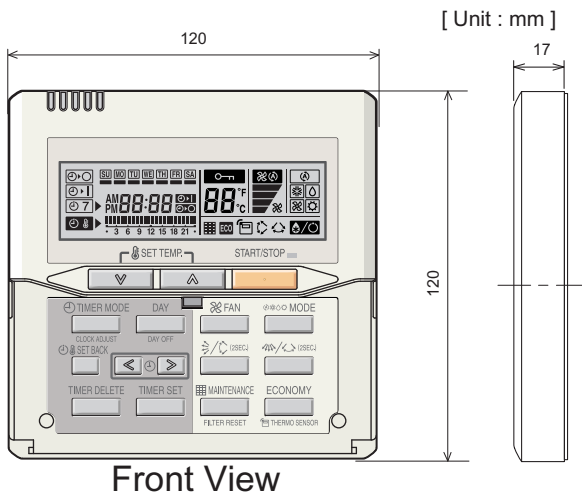

SPECIFICATION

SIZE (H x W x D mm)	120 x 120 x 17
WEIGHT (g)	160
CABLE LENGTH (m)	10
POWER (V)	12

REMOTE CONTROLLER

4. WIRELESS REMOTE CONTROLLER :

UTB - *NA

FEATURES



- * Four kinds of timer setup (ON / OFF / PROGRAM / SLEEP) are possible.
- * Four kinds of timers. Easy operation.
- * Easy to change transmission code (4 patterns) by button operation.

● Simple function setting

Setting of the air conditioner selection function is performed by remote controller.

● Built-in timers

Select from four different timer programs (On/Off/Program/Sleep).

● Program timer

The program timer operates the ON and OFF timer once within a 24 hour period.

● Sleep timer

The sleep timer function automatically corrects the temperature thermostat setting according to the time setting to prevent excessive cooling and heating while sleeping.

Cooling operation/dry operation

When the sleep timer is set, the set temperature automatically rises 1°C every hour. The set temperature can rise up to a maximum of 2°C.

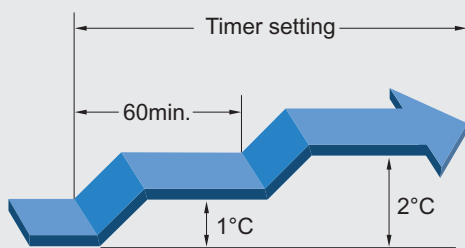

Heating operation

When the sleep timer is set, the set temperature automatically drops 1°C every 30 minutes. The set temperature can drop to a maximum of 4°C.

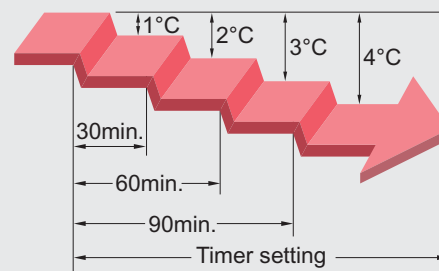

● Simultaneously operation

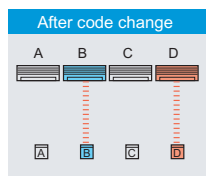
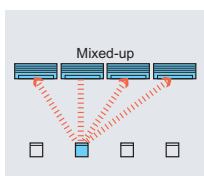

- Code selector switch eliminates unit being wrongly switched. (Up to 4 codes can be set.)



- Wide and precise transmitting range.

1. Press the MODE button for more than five seconds to start the code change.
2. Press the ▲ or ▼ button to select the desired code.
▶ A → B → C → D
3. Press the MODE button again to end the code change.

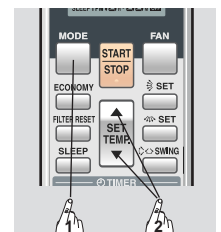

FUNCTIONS

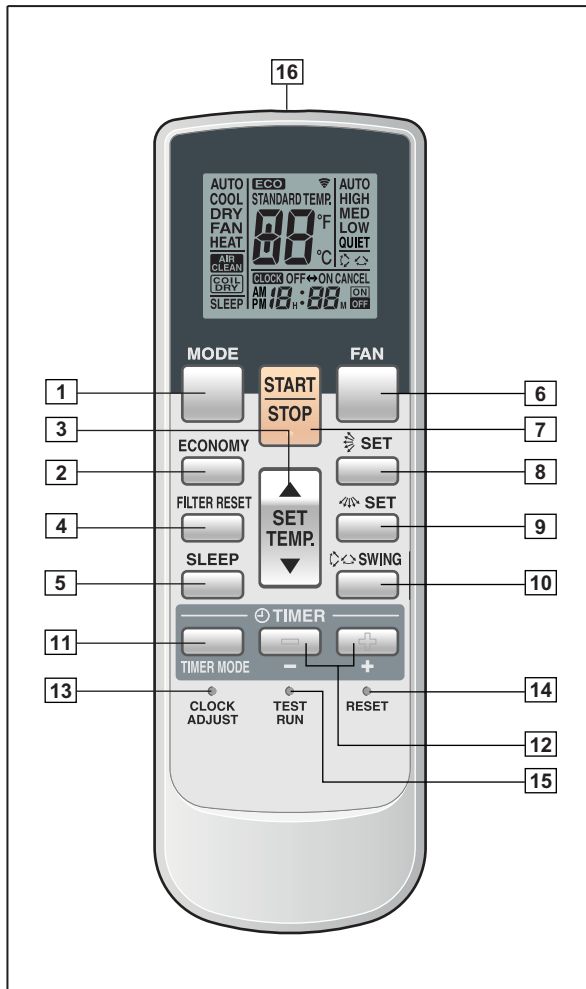

- 1 **MODE button**
Selects the operating mode (AUTO, HEAT, FAN, COOL, DRY).
/Start / end R.C. custom code change. (Max 4 types)
- 2 **Economy button**
- 3 **Set temp. button (▲/▼)**
Set remote controller custom code buttons
Sets the indoor temp./ Sets R.C. custom code.
- 4 **Filter reset button**
- 5 **Sleep button**
Pressed to select sleep timer.
- 6 **Fan button**
Selects the fan speed (AUTO, QUIET, LOW, MED, HIGH).
- 7 **START/STOP button**
Pressed to start and stop operation.
- 8 **Set button (Vertical)**
Air flow direction vertical set button.
- 9 **Set button (Horizontal)**
Air flow direction horizontal set button.
- 10 **Swing button**
Air flow direction swing button.
- 11 **Timer mode button**
Pressed to select the timer mode. (OFF TIMER, ON TIMER, PROGRAM TIMER, TIMER RESET)
- 12 **Timer set () / () button**
Sets the current time and on-off time.
- 13 **Clock adjust button**
Sets the current time.
- 14 **Reset button**
Used when replacing batteries.
- 15 **Test run button**
Used when testing the air conditioner after installation.

Display panel

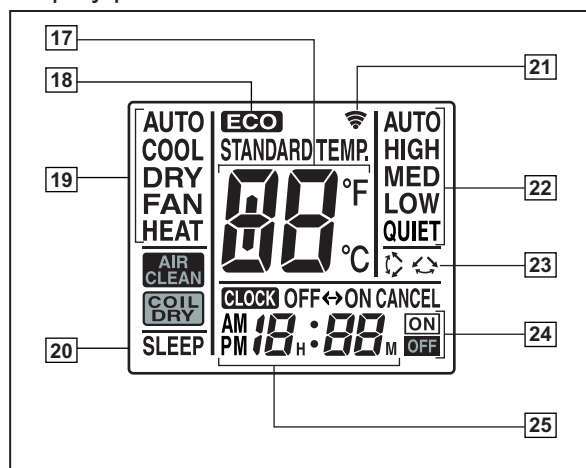

- 16 **Signal transmitter**
- 17 **Temperature set display**
- 18 **Economy display**
- 19 **Operating mode display**
- 20 **Sleep display**
- 21 **Transmit indicator**
- 22 **Fan speed display**
- 23 **Swing display**
- 24 **Timer mode display**
- 25 **Clock display**

SPECIFICATION

SIZE (H x W x D mm)	170 x 56 x 19
WEIGHT (g)	80
ACCESSORY	Holder