

AIR CONDITIONER
Cassette type

DESIGN & TECHNICAL MANUAL

SINGLE
INDOOR



AU*A30LBLU
AU*A36LBLU

OUTDOOR



AO*A30LBTL AO*A30LFTL
AO*A36LBTL AO*A36LFTL

1. INDOOR UNIT

CASSETTE TYPE :

AU*A30LBLU

AU*A36LBLU

CONTENTS

1. INDOOR UNIT

1. FEATURE	01 - 01
2. REMOTE CONTROLLER	01 - 04
3. SPECIFICATIONS	01 - 06
4. DIMENSIONS	01 - 07
5. WIRING DIAGRAMS	01 - 09
6. CAPACITY TABLE	01 - 10
6-1. COOLING CAPACITY.....	01 - 10
6-2. HEATING CAPACITY.....	01 - 11
7. FAN PERFORMANCE	01 - 12
7-1. AIR VELOCITY DISTRIBUTION.....	01 - 12
7-2. AIR FLOW.....	01 - 17
7-3. FRESH AIR.....	01 - 19
7-4. DUCT CONNECTION.....	01 - 20
8. OPERATION NOISE	01 - 22
8-1. NOISE LEVEL CURVE.....	01 - 22
8-2. SOUND LEVEL CHECK POINT.....	01 - 23
9. ELECTRIC CHARACTERISTICS	01 - 24
10. SAFETY DEVICES	01 - 25
11. EXTERNAL INPUT & OUTPUT	01 - 26
11-1. EXTERNAL INPUT.....	01 - 26
11-2. EXTERNAL OUTPUT.....	01 - 27
12. FUNCTION SETTING	01 - 29
12-1. INDOOR UNIT.....	01 - 29
12-2. WIRED REMOTE CONTROLLER.....	01 - 30
13. OPTIONAL PARTS	01 - 33

1. FEATURE

MODEL

INDOOR UNIT	OUTDOOR UNIT
AU*A30LBLU	AO*A30LBTL AO*A30LFTL
AU*A36LBLU	AO*A36LBTL AO*A36LFTL



FEATURES

● Energy saving

- All DC design
- Heat exchange efficiency increased and larger air flow by adoption of new type turbo fan

● Advancement in comfort

- Quiet operation was realized by adoption of new type turbo fan
- Improvement of air stream

① Adoption of high efficiency turbo fan

High efficiency achieved by equaling the performance of the wing and air passing the heat exchanger

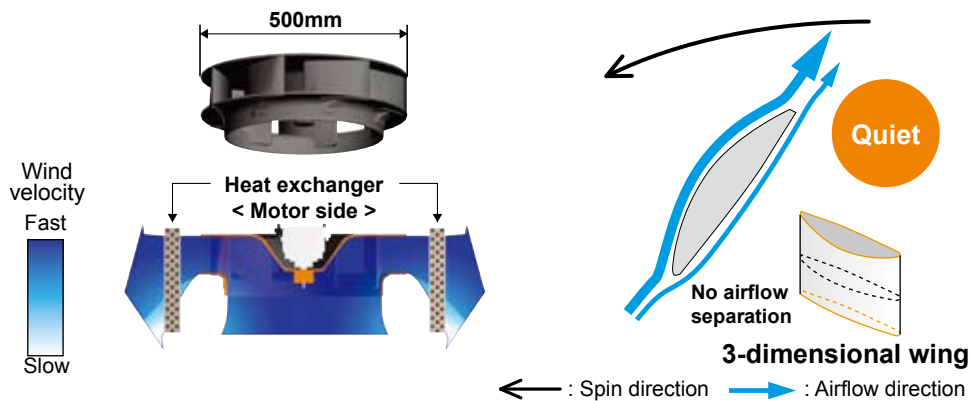

② Improvement of the flap

Making space between the ceiling, the air flows far wide and ceiling does not get dirty.



③Wide & powerful airflow

The wind is widely delivered by a high efficiency fan and round flap.

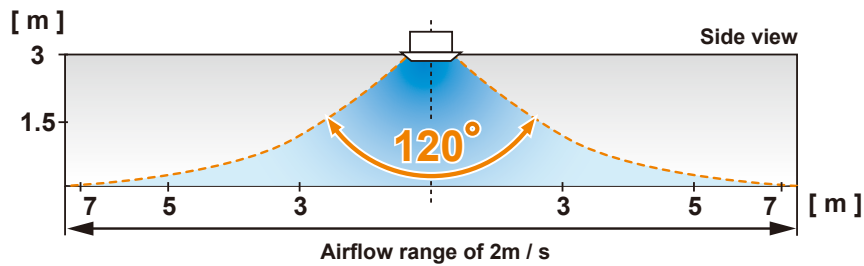

●Improvement of installation & maintenance

- Adjustment of nut is possible after installation

Mounting position of body can be fine adjusted after Decoration panel mounting.

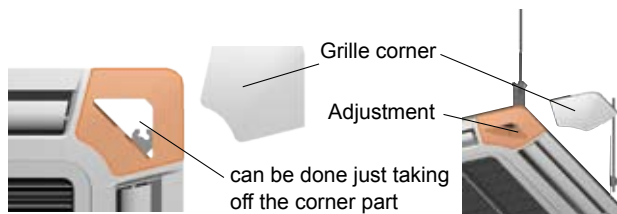

●High lift drain pump

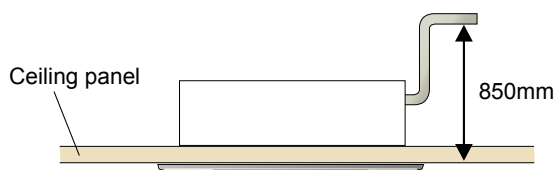

●Simplification of drain water check

Drain and contamination check are possible without removing the decoration panel.

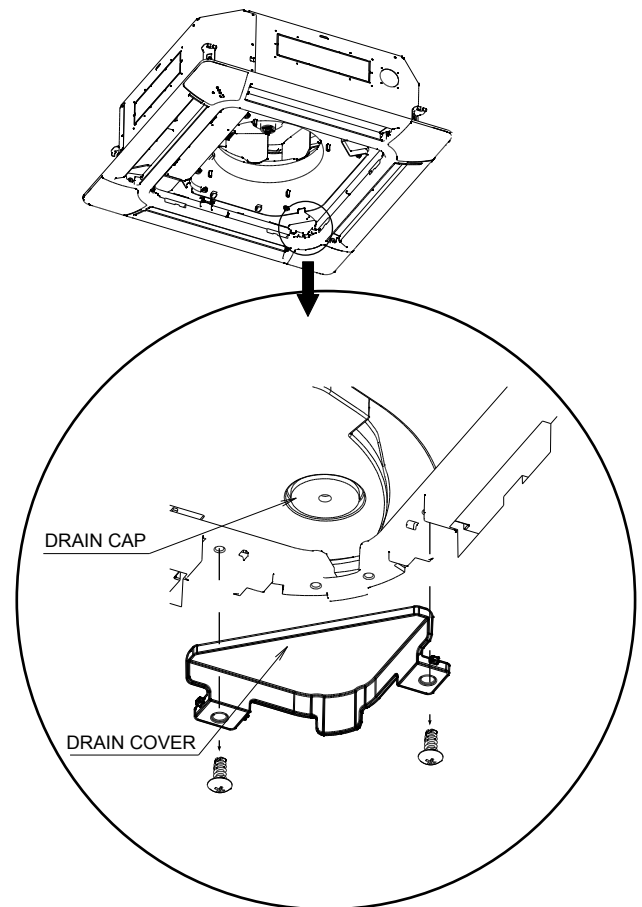

●Easy installation

Easy setting by wired remote controller

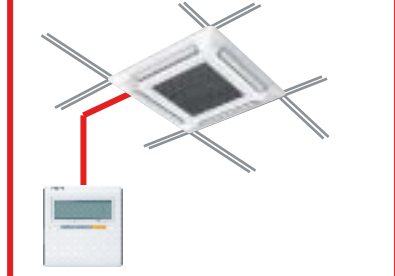

Can be easily checked by removing the drain cover.

FUNCTION SETTING

● Outlet direction selection

- Performs operation matched to the number of outlets when 4 directions are unnecessary and outlets are blocked when the ceiling cassette is installed in a corner, etc.

4-way direction



3-way direction



4-way direction mode: Set when there are 4 outlets (shipped state).

3-way direction mode: Set when there are 3 outlets.

● Ceiling switching function

Also delivers air to high ceilings by selecting the mode and raising the air flow according to the height of the ceiling.

High ceiling (Mode 2)

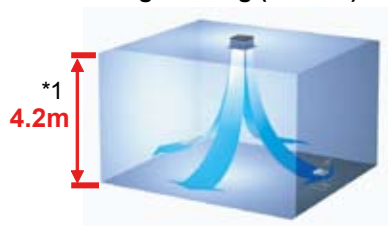

*1 : AU*A30L is 3.6m

Standard ceiling (Standard)



Low ceiling (Mode 1)



Standard ...Operates at normal air flow.

Mode 1 ...Air flow becomes smaller than normal.

Mode 2 ...Air flow becomes greater than normal.

● Filter sign

The indoor unit has sign to inform the user that it is time to clean the filter

● Cooling room temperature correction

● Heating room temperature correction

● Auto restart

The units restart automatically when the current was returned even when there was a power interruption during operation.

● Room temperature sensor switching

Switches from room temperature judgment by room temperature sensor attached to indoor unit body to room temperature judgment by room temperature sensor attached to wired remote controller.

● Economy operation

The power consumption can be reduced.

Powerful mode ...Standard

Soft mode ...Performs operation which reduces the power consumption

2. REMOTE CONTROLLER

WIRED REMOTE CONTROLLER

FEATURES

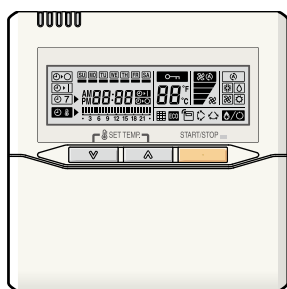

- * Various timer setup (ON / OFF / WEEKLY) are possible.
- * Equipped with weekly timer as standard function. (2 times Start / Stop per day for a week)
- * When setting up a timer, operation mode and a temperature setup can be changed.
- * When a failure occurs, the error code is displayed. (Maximum of 16)
- * Error indication. (A maximum of 16 error histories are memorizable.)
- * Up to 16 indoor units can be simultaneously controlled.
- * Economy operation are possible.
- * Easy installation with a slim shape with no bulge in the back.
- * The room temperature can be controlled by being detected the temperature accurately with built-in thermo sensor.

Simple function setting

Setting of the air conditioner selection function is performed by remote controller.

High performance and compact size

Three functions are combined in one unit.



Built-in timers

Weekly timer

Possible to set ON/OFF time to operate twice each day of the week.

Setup screen example (Set to Wednesday: 8:00 to 20:00.)

Setback timer

Possible to set temperature for two time spans and for each day of the week.

Setup screen example (Set from Sunday to Saturday: 12:00 to 15:00, 28 °C.)

At "Weekly timer" + "Set back timer" setup

Easy-to-understand operation

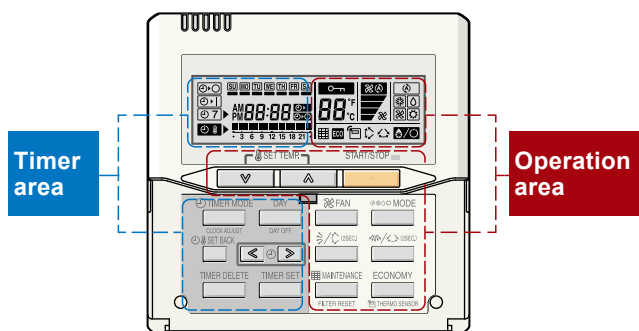

[Variable timer control]

The operation/display sections are zoned according to time and operation, enabling variable programming to match application.

Simple installation

Components are compatible with standard switch boxes. Flat back construction allows equipment to be installed wherever it is needed.

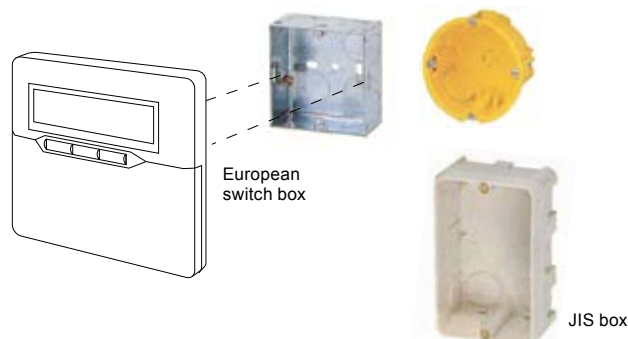

FUNCTIONS

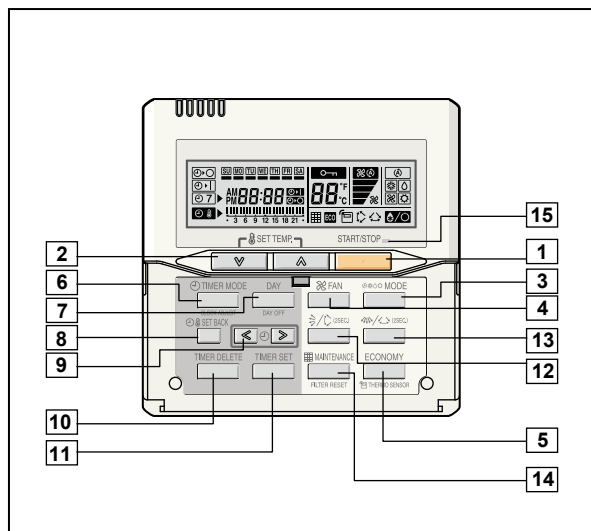

Display panel

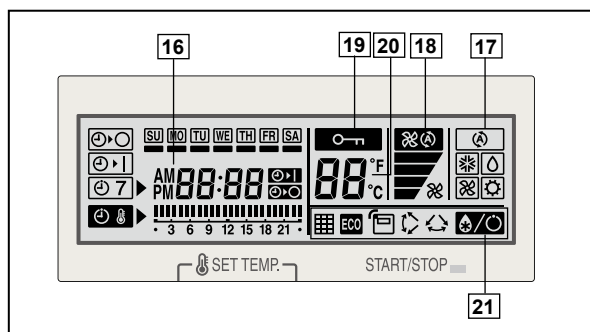

DIMENSION

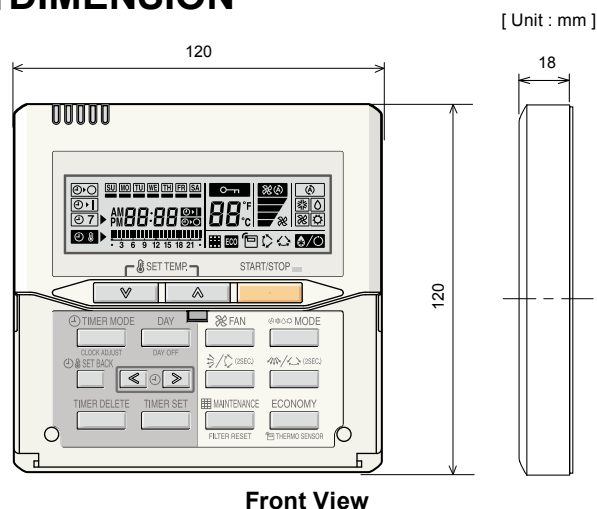

- 1 START/STOP button**
Pressed to start and stop operation.
- 2 Set temperature button**
Selects the setting temperature.
- 3 Master control button**
Selects the operating mode(AUTO, HEAT, FAN, COOL, DRY).
- 4 Fan control button**
Selects the fan speed (AUTO, QUIET, LOW, MED, HIGH).
- 5 Economy button**
Turns the economy efficient mode on and off.
- 6 Timer mode (CLOCK ADJUST) button**
Selects the timer mode (OFF TIMER, ON TIMER, WEEKLY TIMER). Set the current time.
- 7 Day (DAY OFF) button**
Temporarily cancels of one day timer.
- 8 Set back button**
Pressed to select the set back timer.
- 9 Set time button**
Pressed to set time.
- 10 Delete button**
The schedule of a weekly timer is deleted.
- 11 Set button**
Sets the date, hour, minute and on-off time.
- 12 Vertical airflow direction and swing button**
Push for two seconds to change the swing mode.
- 13 Horizontal airflow direction and swing button**
Push for two seconds to change the swing mode.
- 14 Filter button**
- 15 Operation lamp**
Lights during operation and when the timer is on.
- 16 Timer and clock display**
- 17 Operation mode display**
- 18 Fan speed display**
- 19 Operation lock display**
- 20 Temperature display**
- 21 Function display**
 - Defrost display
 - Thermo sensor display
 - Economy display
 - Vertical swing display
 - Horizontal swing display
 - Filter display

Functions will be different due to type of indoor unit.
For details, please see operation manual.

SPECIFICATION

SIZE	(H x W x D mm)	120 x 120 x 18
WEIGHT	(g)	160
CABLE LENGTH	(m)	10
POWER	(V)	12

3. SPECIFICATIONS

Type				CASSETTE MODEL				
				INVERTER HEATPUMP				
Model name		Indoor unit		AU*A30LBLU		AU*A36LBLU		
		Outdoor unit		AO*A30LBTL	AO*A30LFTL	AO*A36LBTL	AO*A36LFTL	
Power source				230V~ 50Hz				
Available voltage range				198-264V~ 50Hz				
European energy label				Cooling	A		A	
				Heating	A		A	
Capacity	Cooling	Rated	kW	8.50		10.00		
			Btu/h	29000		34100		
		Min.-Max.	kW	2.80 - 10.00		2.80 - 11.20		
			Btu/h	9500 - 34100		9500 - 38200		
	Heating	Rated	kW	10.00		11.20		
			Btu/h	34100		38200		
		Min.-Max.	kW	2.70 - 11.20		2.70 - 12.70		
			Btu/h	9200 - 38200		9200 - 43300		
Input power	Cooling	Rated	kW	2.65		3.11	3.12	
		Max.		3.88		4.56	4.22	
	Heating	Rated		2.77		3.02		
		Max.		3.88		4.56		
Current	Cooling	Rated	A	11.6		13.7		
		*Max.		17.0		20.0	18.5	
	Heating	Rated		12.2		13.3		
		*Max.		17.0		20.0		
EER			Cooling	3.21		3.21		
COP			Heating	3.61		3.71		
Moisture removal			l/h (pints/h)	2.5(5.3)		3.5(7.4)		
Fan	Airflow rate	Cooling	High	m ³ /h	1600		1800	
			Med		1400		1400	
			Low		1270		1270	
			Quiet		1150		1150	
		Heating	High		1600		1800	
			Med		1400		1400	
			Low		1270		1270	
			Quiet		1150		1150	
	Type × Q'ty		Turbo Fan × 1					
	Motor output			W	80		80	
Sound pressure level	Cooling	High	dB(A)	40		43		
				Med	38		38	
				Low	36		36	
				Quiet	32		32	
	Heating	High		High	40		43	
				Med	38		38	
				Low	36		36	
				Quiet	32		32	
Heat exchanger type	Dimensions (H × W × D)		mm	252 × 2030 × 26.6		252 × 2030 × 26.6		
	Fin pitch			252 × 2093 × 26.6		252 × 2093 × 26.6		
	Rows x Stages		1.2		1.2			
	Pipe type		Copper		Copper			
	Fin type		Aluminium		Aluminium			
Enclosure (Panel)		Material	HIPS					
		Colour	WHITE Approximate colour of MUNSELL N 9.25/					
Dimensions (H×W×D)	NET	Unit	mm	288 × 842 × 842				
		Panel		50 × 950 × 950				
	Gross	Unit		360 × 960 × 985				
		Panel		115 × 1020 × 1000				
Weight	NET	Unit	kg	26				
		Panel		5.5				
	Gross	Unit		32				
		Panel		8.5				
Connection pipe	Size	Liquid	mm	Ø 9.52 (Ø 3 / 8 in.)		Ø 9.52 (Ø 3 / 8 in.)		
		Gas		Ø15.88 (Ø 5 / 8 in.)		Ø15.88 (Ø 5 / 8 in.)		
	Method	Flare		Flare				
Operation range	Cooling	°C	18 to 32		18 to 32			
		%RH	80 or less		80 or less			
	Heating	°C	16 to 30		16 to 30			
Remote controller type				Wired				
Drain pipe	Material			PVC (VP25)				
	Size			mm Outer diameter : 32.0 / Inner diameter : 25.0				

Note :
 Specifications are based on the following conditions.
 Cooling : Indoor temperature of 27 °CDB / 19 °CWB and outdoor temperature of 35 °CDB/24 °CWB.
 Heating : Indoor temperature of 20 °CDB / 15 °CWB and outdoor temperature of 7 °CDB/6 °CWB.
 Pipe length : 5 m, Height difference : 0 m.(Outdoor unit - Indoor unit)
 The maximum current and the maximum input value are the maximum values when operated within the operation range(temperature)
 *The maximum current is the total current of indoor unit and outdoor unit.

4. DIMENSIONS

MODEL: AU*A30L, AU*A36L

● Ceiling opening and hanging bolt pitch

(Unit : mm)

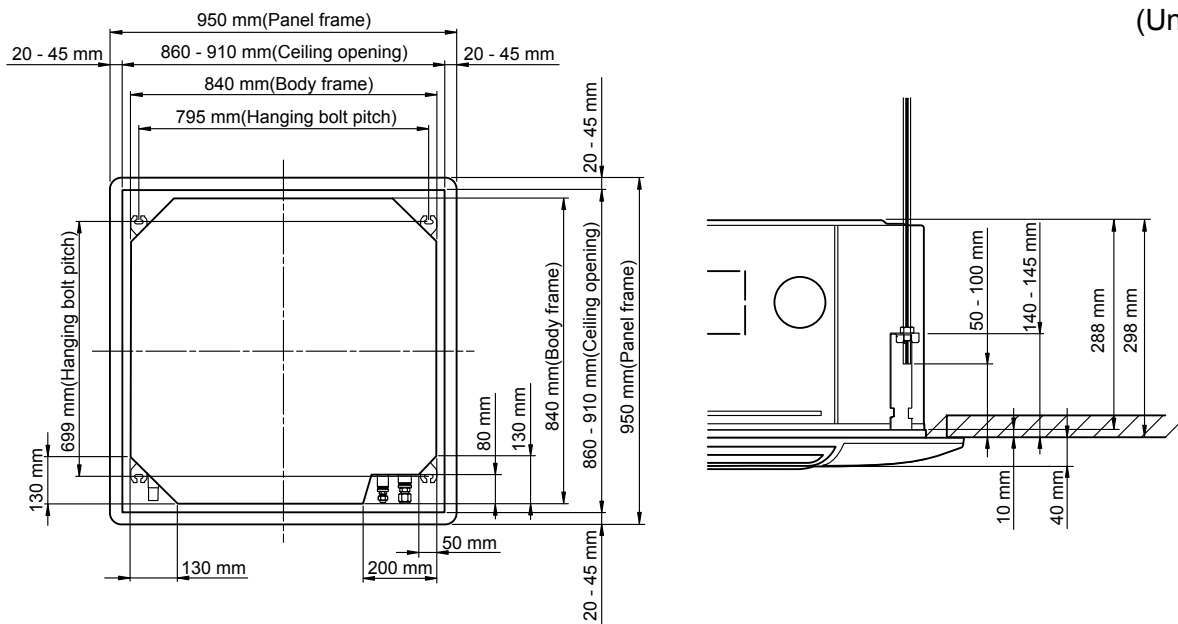

● Refrigerant piping and drain piping positions

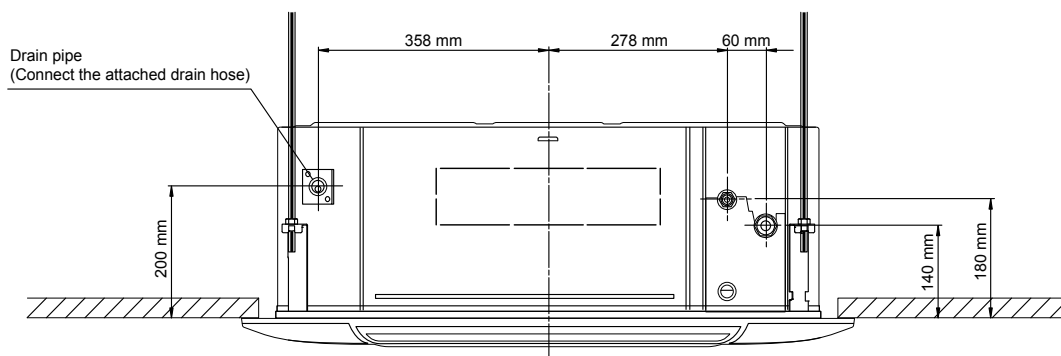

● Airflow split-flow duct and fresh air inlet positions

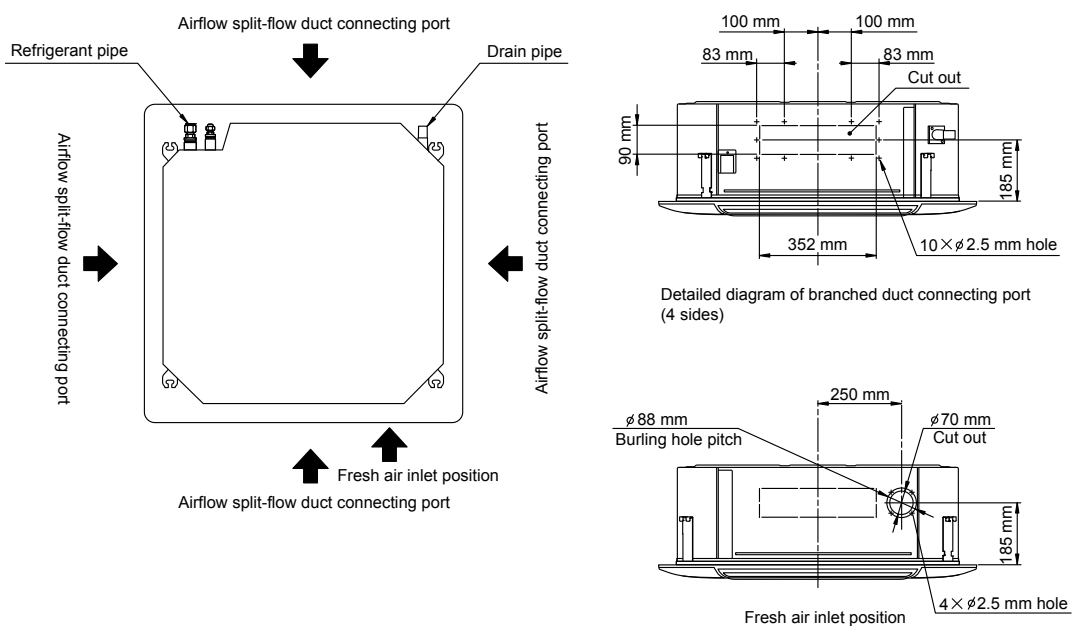

■ INSTALLATION PLACE

(Unit : mm)

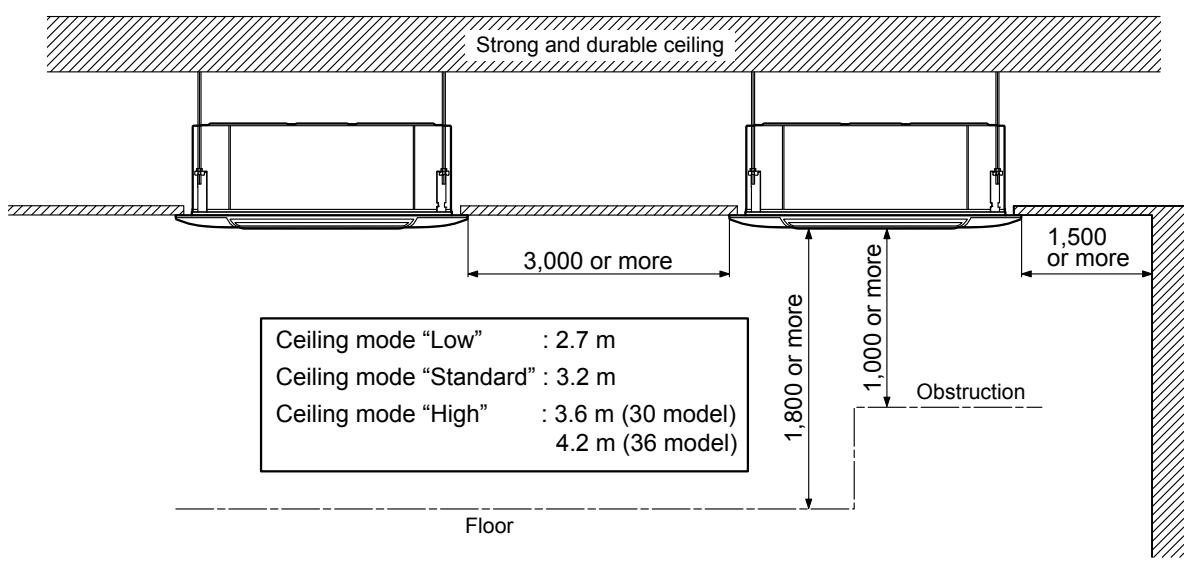

● 3-way directions setting

(Unit : mm)

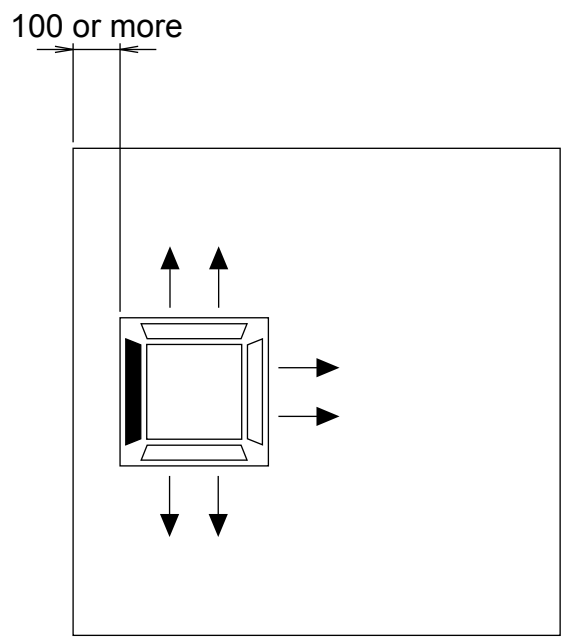

To set "3-way directions", the air outlet shutter plate (UTR-YDZC) sold separately must be installed and "outlet-direction" switched to "3-way" by remote controller.

5. WIRING DIAGRAMS

MODEL: AU*A30L, AU*A36L

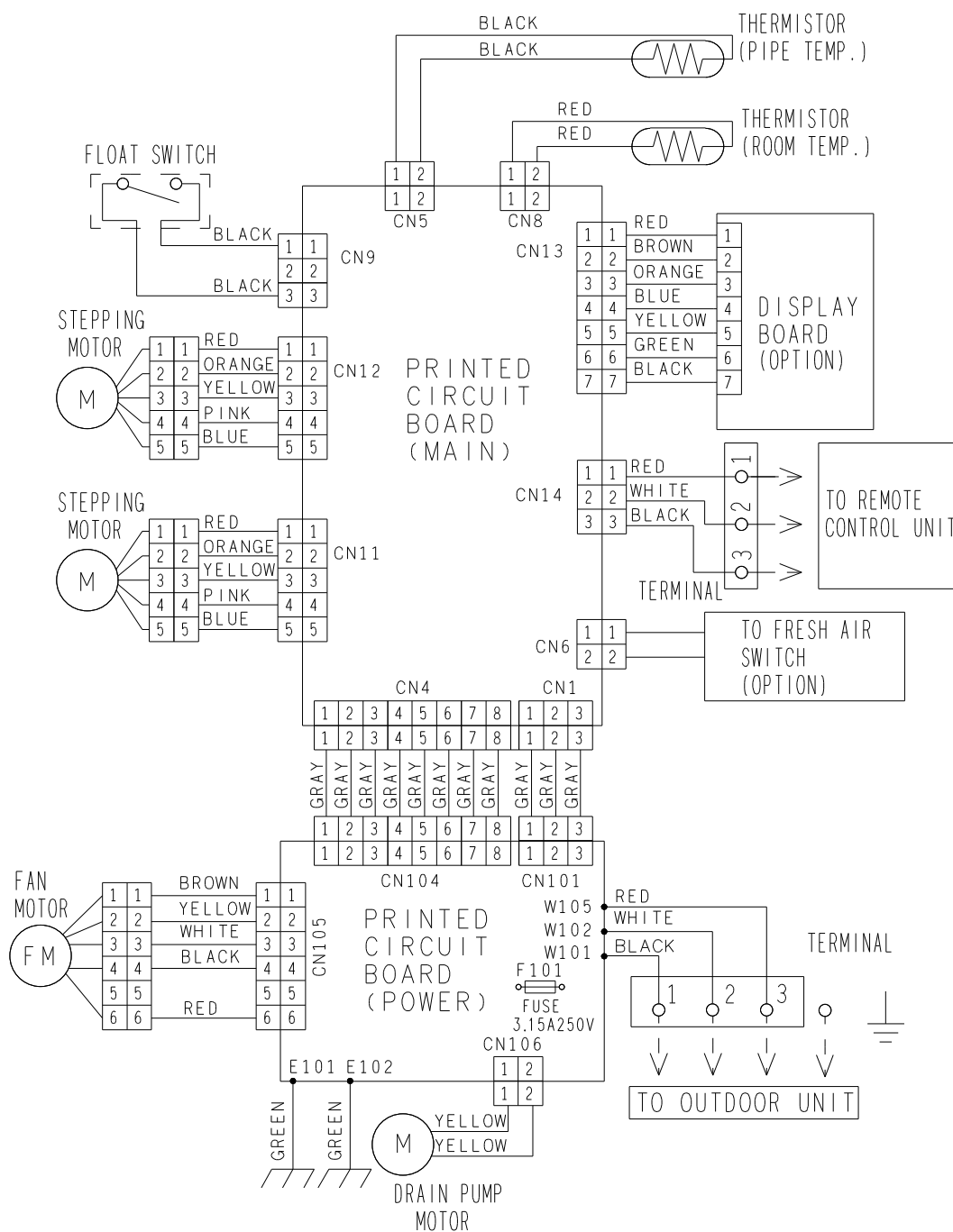

6. CAPACITY TABLE

6-1. COOLING CAPACITY

This table is created using the maximum capacity.

MODEL: AU*A30L

AFR	26.7
-----	------

		Indoor temperature																				
		18			21			23			25			27			29			32		
		12			15			16			18			19			21			23		
Outdoor temperature	°CDB	TC	SHC	IP	TC	SHC	IP	TC	SHC	IP	TC	SHC	IP	TC	SHC	IP	TC	SHC	IP	TC	SHC	IP
	-15	8.67	6.58	1.20	9.66	6.62	1.22	9.99	7.20	1.22	10.65	7.22	1.24	10.98	7.80	1.24	11.64	7.77	1.25	12.29	8.27	1.27
	-10	8.52	6.38	1.64	9.49	6.42	1.66	9.81	6.98	1.67	10.46	7.00	1.69	10.79	7.56	1.70	11.43	7.53	1.71	12.08	8.02	1.73
	0	8.12	6.26	2.11	9.04	6.30	2.15	9.35	6.85	2.16	9.97	6.87	2.18	10.28	7.42	2.19	10.89	7.39	2.21	11.51	7.87	2.23
	5	7.99	6.11	2.14	8.90	6.14	2.17	9.21	6.68	2.19	9.81	6.70	2.21	10.12	7.23	2.22	10.72	7.21	2.24	11.33	7.68	2.26
	10	7.96	6.19	2.19	8.87	6.23	2.23	9.17	6.77	2.24	9.77	6.79	2.26	10.07	7.34	2.27	10.68	7.31	2.29	11.28	7.78	2.32
	15	8.63	6.48	2.41	9.62	6.52	2.45	9.94	7.09	2.46	10.60	7.11	2.49	10.93	7.68	2.50	11.58	7.65	2.53	12.24	8.14	2.55
	20	9.82	7.03	2.97	10.94	7.07	3.01	11.31	7.69	3.03	12.06	7.71	3.06	12.43	8.33	3.08	13.18	8.30	3.11	13.92	8.84	3.14
	25	9.48	6.89	3.31	10.56	6.93	3.36	10.92	7.53	3.38	11.64	7.56	3.41	12.00	8.16	3.43	12.72	8.13	3.46	13.44	8.66	3.50
	30	8.81	6.70	3.34	9.81	6.74	3.39	10.15	7.32	3.41	10.81	7.35	3.44	11.15	7.93	3.46	11.82	7.90	3.50	12.49	8.42	3.53
	35	7.90	6.12	3.35	8.80	6.16	3.40	9.10	6.69	3.42	9.70	6.71	3.45	10.00	7.25	3.47	10.60	7.22	3.51	11.20	7.69	3.54
	40	6.16	5.13	2.94	6.86	5.16	2.99	7.09	5.61	3.01	7.56	5.63	3.04	7.80	6.08	3.05	8.26	6.05	3.08	8.73	6.45	3.11
46	5.44	4.92	2.91	6.06	4.95	2.96	6.27	5.39	2.97	6.68	5.40	3.00	6.89	5.83	3.02	7.30	5.81	3.05	7.71	6.19	3.08	

MODEL: AU*A36L

AFR	30.0
-----	------

		Indoor temperature																				
		18			21			23			25			27			29			32		
		12			15			16			18			19			21			23		
Outdoor temperature	°CDB	TC	SHC	IP	TC	SHC	IP	TC	SHC	IP	TC	SHC	IP	TC	SHC	IP	TC	SHC	IP	TC	SHC	IP
	-15	9.33	7.37	1.29	10.39	7.41	1.31	10.74	8.06	1.32	11.45	8.08	1.33	11.80	8.73	1.34	12.51	8.70	1.35	13.22	9.26	1.36
	-10	9.22	7.23	1.69	10.27	7.27	1.71	10.62	7.90	1.72	11.32	7.93	1.74	11.67	8.56	1.75	12.37	8.53	1.77	13.07	9.08	1.78
	0	8.77	7.13	2.18	9.77	7.17	2.22	10.10	7.80	2.23	10.77	7.82	2.25	11.10	8.45	2.26	11.77	8.41	2.29	12.44	8.96	2.31
	5	8.69	6.98	2.25	9.68	7.02	2.28	10.01	7.64	2.29	10.67	7.66	2.32	11.00	8.27	2.33	11.66	8.24	2.35	12.32	8.78	2.38
	10	8.62	7.06	2.25	9.60	7.10	2.29	9.93	7.72	2.30	10.58	7.75	2.32	10.91	8.37	2.34	11.56	8.33	2.36	12.22	8.88	2.38
	15	9.17	7.17	2.42	10.21	7.22	2.46	10.56	7.85	2.47	11.25	7.87	2.50	11.60	8.50	2.51	12.30	8.47	2.54	13.00	9.02	2.56
	20	10.70	7.92	2.99	11.92	7.97	3.03	12.33	8.66	3.05	13.14	8.69	3.08	13.54	9.39	3.10	14.36	9.35	3.13	15.17	9.96	3.16
	25	10.64	8.02	3.32	11.86	8.06	3.38	12.26	8.77	3.39	13.07	8.79	3.43	13.47	9.50	3.45	14.28	9.46	3.48	15.09	10.08	3.51
	30	10.24	7.76	4.05	11.40	7.81	4.11	11.79	8.49	4.13	12.57	8.51	4.17	12.96	9.19	4.19	13.73	9.16	4.24	14.51	9.75	4.28
	35	8.85	6.78	4.03	9.86	6.82	4.10	10.19	7.42	4.12	10.86	7.44	4.16	11.20	8.04	4.18	11.87	8.01	4.22	12.54	8.53	4.26
	40	6.80	5.96	3.09	7.58	6.00	3.14	7.84	6.52	3.16	8.35	6.54	3.19	8.61	7.07	3.20	9.13	7.04	3.24	9.65	7.50	3.27
46	6.11	5.84	2.96	6.81	5.87	3.01	7.04	6.39	3.02	7.50	6.41	3.05	7.74	6.92	3.07	8.20	6.89	3.10	8.67	7.34	3.13	

AFR : Air Flow Rate (m³/min)
 TC : Total Capacity (kW)
 SHC : Sensible Heat Capacity (kW)
 IP : Input Power (kW)

6-2. HEATING CAPACITY

This table is created using the maximum capacity.

MODEL: AU*A30L

AFR	26.7
-----	------

		°CDB	Indoor temperature									
			16		18		20		22		24	
Outdoor temperature	°CDB	°CWB	TC	IP	TC	IP	TC	IP	TC	IP	TC	IP
	-15	-16	8.34	3.37	8.14	3.44	7.94	3.51	7.75	3.58	7.55	3.65
	-10	-11	8.79	3.38	8.58	3.45	8.37	3.52	8.16	3.59	7.95	3.66
	-5	-7	9.55	3.41	9.32	3.48	9.09	3.55	8.86	3.62	8.64	3.69
	0	-2	10.12	3.37	9.88	3.44	9.64	3.51	9.40	3.58	9.16	3.65
	5	3	11.23	3.35	10.96	3.42	10.69	3.49	10.43	3.56	10.16	3.62
	7	6	11.76	3.33	11.48	3.40	11.20	3.47	10.92	3.54	10.64	3.61
	10	8	12.12	3.30	11.83	3.37	11.54	3.44	11.25	3.51	10.96	3.57
	15	10	10.86	2.52	10.60	2.57	10.34	2.62	10.09	2.67	9.83	2.71
	20	15	10.87	2.23	10.61	2.28	10.35	2.33	10.09	2.37	9.83	2.41
24	18	11.31	2.25	11.04	2.30	10.78	2.34	10.51	2.39	10.24	2.43	

MODEL: AU*A36L

AFR	30.0
-----	------

		°CDB	Indoor temperature									
			16		18		20		22		24	
Outdoor temperature	°CDB	°CWB	TC	IP	TC	IP	TC	IP	TC	IP	TC	IP
	-15	-16	9.63	3.92	9.40	4.00	9.17	4.08	8.94	4.17	8.71	4.25
	-10	-11	9.70	3.96	9.47	4.04	9.24	4.13	9.01	4.21	8.77	4.29
	-5	-7	10.69	4.07	10.43	4.16	10.18	4.24	9.92	4.33	9.67	4.41
	0	-2	12.54	3.99	12.24	4.08	11.94	4.16	11.64	4.24	11.34	4.33
	5	3	13.18	3.81	12.87	3.89	12.55	3.97	12.24	4.05	11.92	4.13
	7	6	13.34	3.36	13.02	3.43	12.70	3.50	12.38	3.57	12.07	3.64
	10	8	13.74	3.19	13.42	3.26	13.09	3.33	12.76	3.39	12.43	3.46
	15	10	12.26	2.55	11.97	2.60	11.67	2.65	11.38	2.71	11.09	2.75
	20	15	12.28	2.26	11.99	2.31	11.69	2.36	11.40	2.40	11.11	2.44
24	18	12.80	2.28	12.49	2.32	12.19	2.37	11.88	2.42	11.58	2.46	

AFR : Air Flow Rate (m³/min)
TC : Total Capacity (kW)
IP : Input Power (kW)

7. FAN PERFORMANCE

7-1. AIR VELOCITY DISTRIBUTION

7-1-1. STANDARD MODE

■ MODEL: AU*A30L

Note:
 Condition
 Fan speed : High
 Operation mode : FAN
 Ceiling mode : Standard

● 4-way air outlet

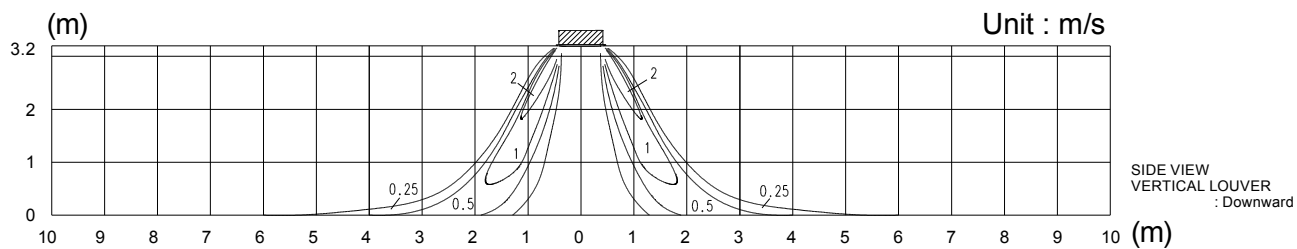
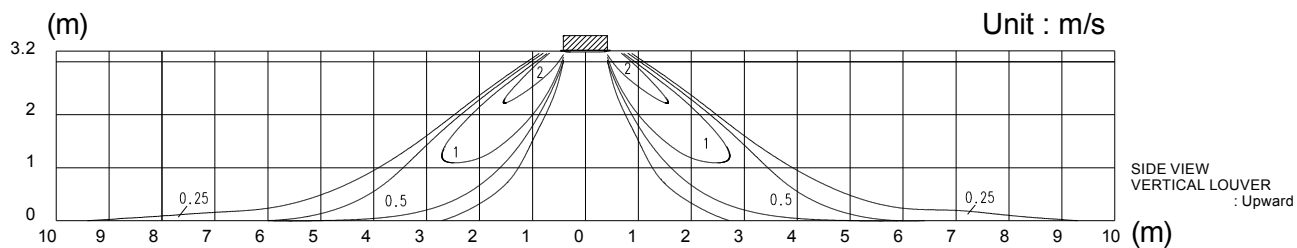
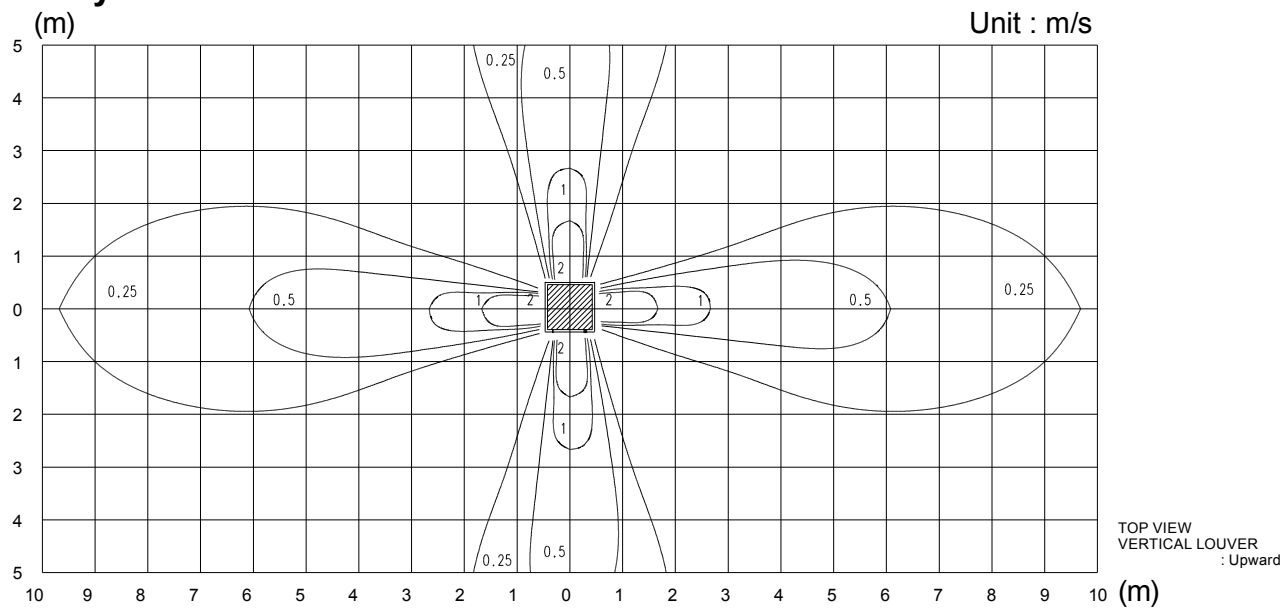

Note:
 Condition
 Fan speed : High
 Operation mode : FAN
 Ceiling mode : Standard

■ **MODEL: AU*A36L**

● **4-way air outlet**

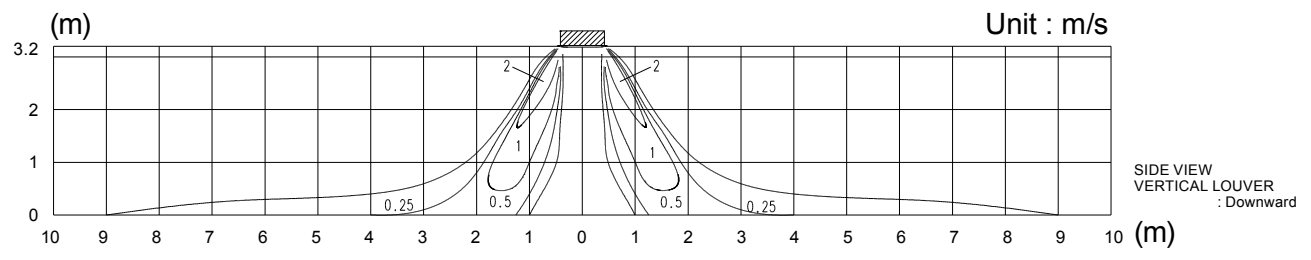
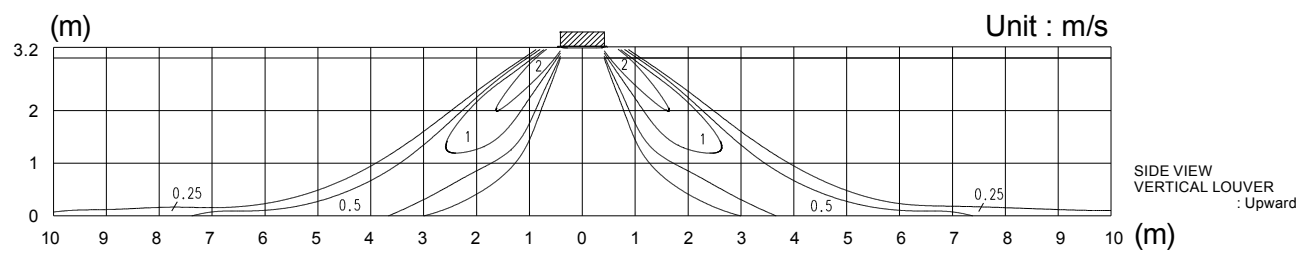
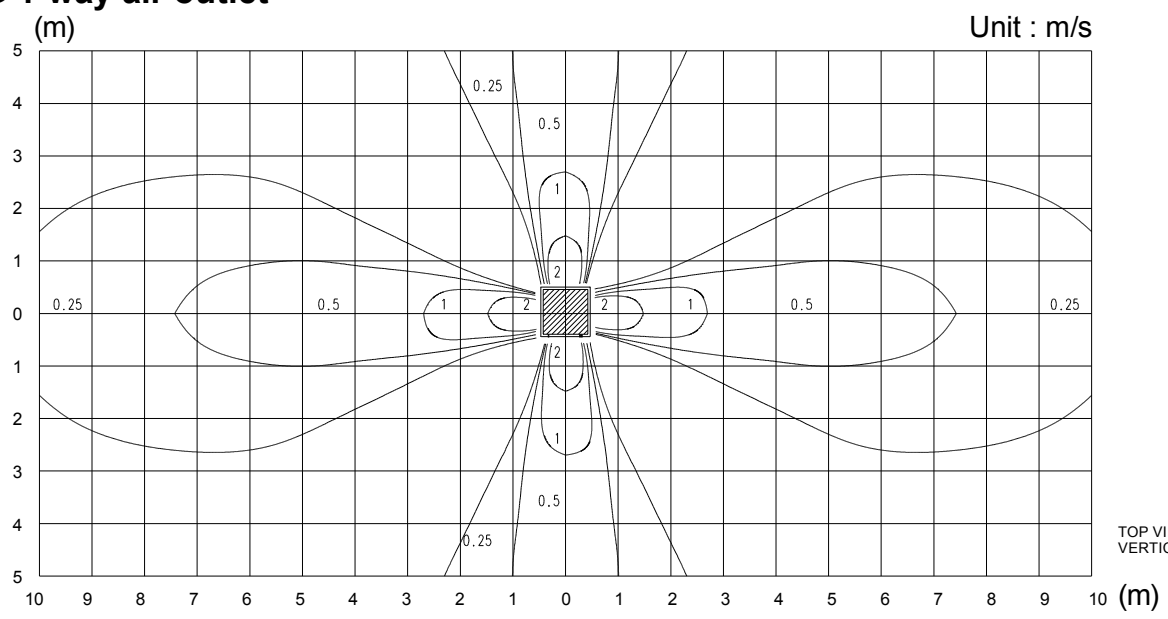

Note:
 Condition
 Fan speed : High
 Operation mode : FAN
 Ceiling mode : Standard

■ MODEL: AU*#A30L

● 3-way air outlet

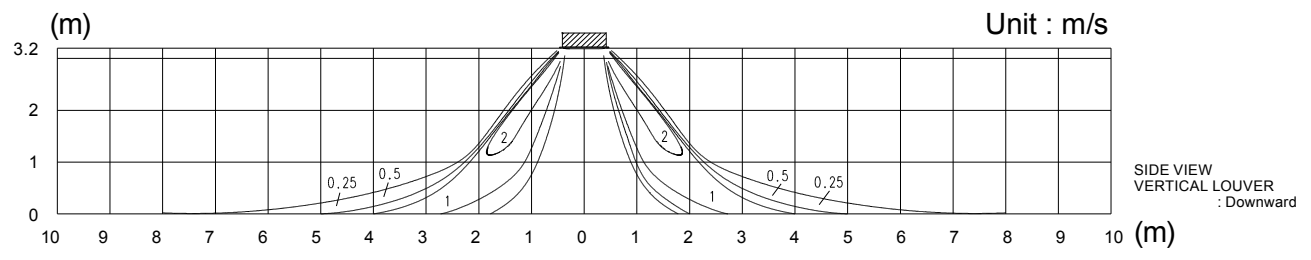
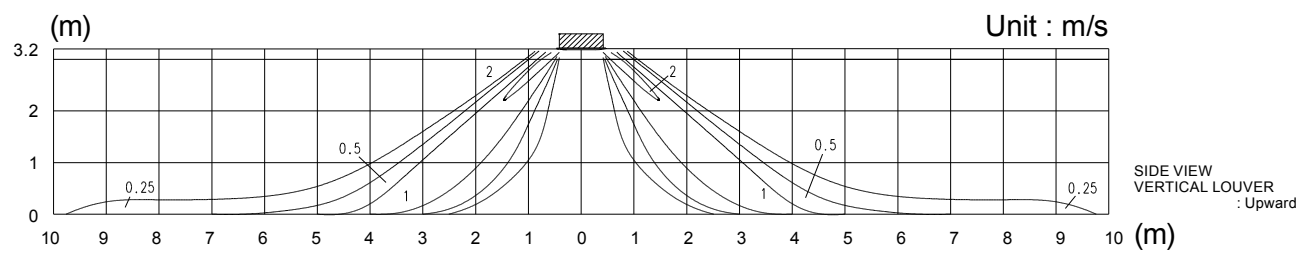
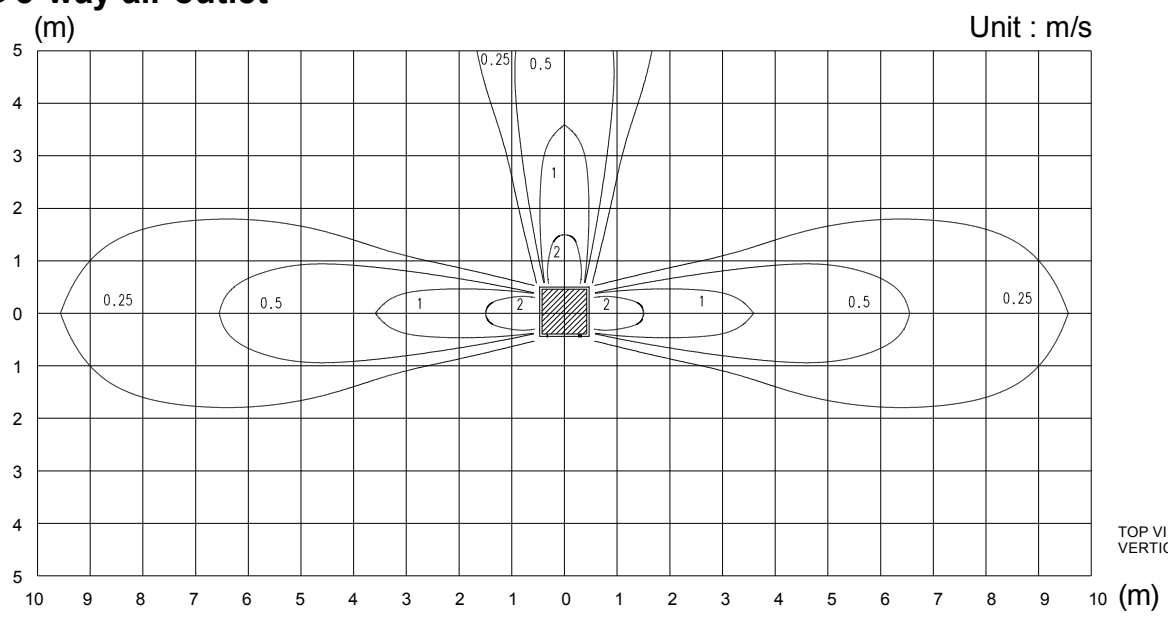

Note:
 Condition
 Fan speed : High
 Operation mode : FAN
 Ceiling mode : Standard

■ MODEL: AU*A36L

● 3-way air outlet

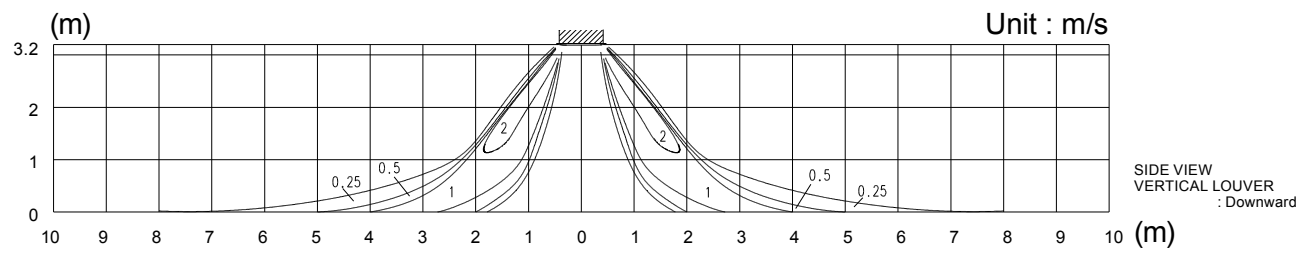
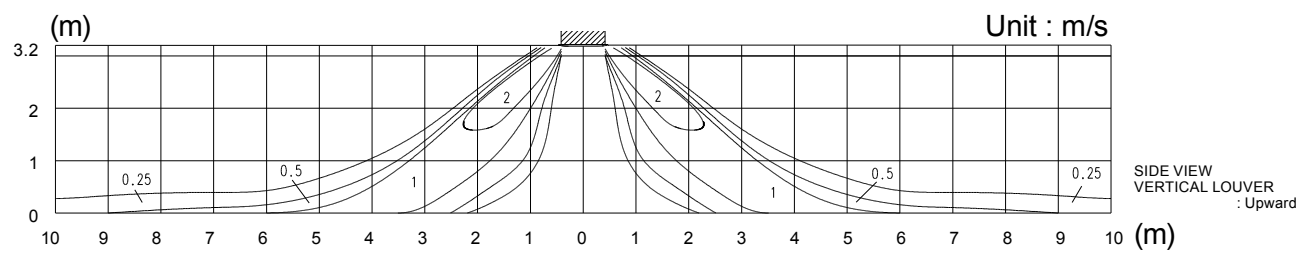
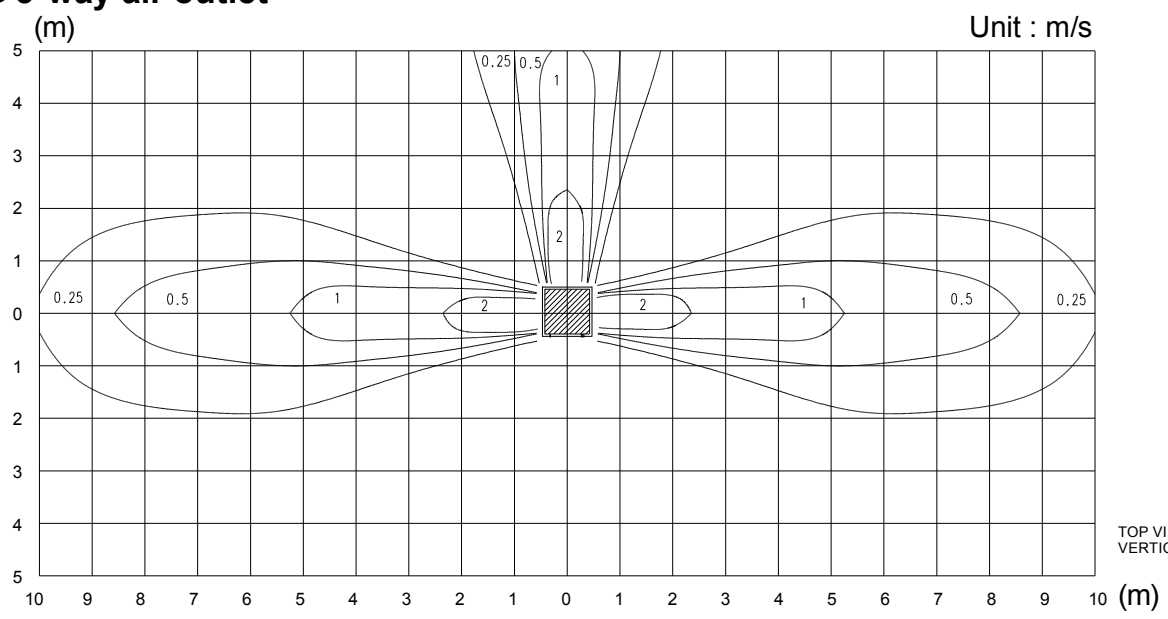

Note:
 Condition
 Fan speed : High
 Operation mode : FAN
 Ceiling mode : Standard

7-1-2. SPECIAL UPWARD MODE

■ MODEL: AU*A30L

● 4-way air outlet

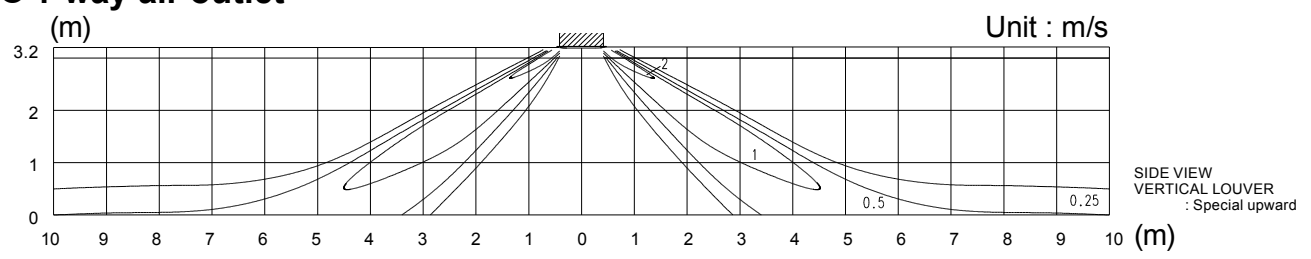

■ MODEL: AU*A36L

● 4-way air outlet

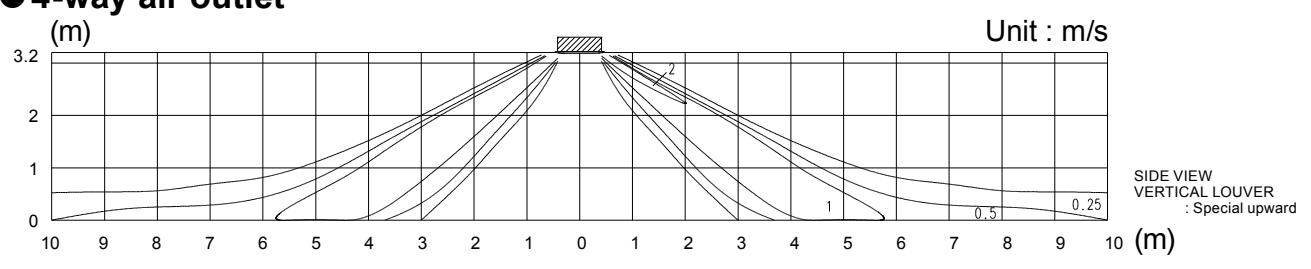

7-2. AIR FLOW

7-2-1. 4-WAY OUTLET

■ MODEL: AU*A30L

● Cooling / Heating

Fan speed	Number of rotations (r.p.m)	Airflow	
HIGH	570	m ³ /h	1600
		l/s	444
		CFM	942
MED	510	m ³ /h	1400
		l/s	389
		CFM	824
LOW	470	m ³ /h	1270
		l/s	353
		CFM	747
QUIET	420	m ³ /h	1150
		l/s	319
		CFM	677

■ MODEL: AU*A36L

● Cooling / Heating

Fan speed	Number of rotations (r.p.m)	Airflow	
HIGH	640	m ³ /h	1800
		l/s	500
		CFM	1059
MED	510	m ³ /h	1400
		l/s	389
		CFM	824
LOW	470	m ³ /h	1270
		l/s	353
		CFM	747
QUIET	420	m ³ /h	1150
		l/s	319
		CFM	677

7-2-2. 3-WAY OUTLET

■ MODEL: AU*A30L

● Cooling / Heating

Fan speed	Number of rotations (r.p.m)	Airflow		
			*Max.	*Min.
HIGH	610	m ³ /h	1550	1350
		l/s	431	375
		CFM	912	794
MED	550	m ³ /h	1350	1200
		l/s	375	333
		CFM	794	706
LOW	510	m ³ /h	1250	1100
		l/s	347	306
		CFM	736	647
QUIET	460	m ³ /h	1100	950
		l/s	306	264
		CFM	647	559

■ MODEL: AU*A36L

● Cooling / Heating

Fan speed	Number of rotations (r.p.m)	Airflow		
			*Max.	*Min.
HIGH	680	m ³ /h	1700	1550
		l/s	472	431
		CFM	1000	912
MED	550	m ³ /h	1350	1200
		l/s	375	333
		CFM	794	706
LOW	510	m ³ /h	1250	1100
		l/s	347	306
		CFM	736	647
QUIET	460	m ³ /h	1100	950
		l/s	306	264
		CFM	647	559

*Air flow can be changed according to the direction in which the outlet is blocked.

7-3. FRESH AIR

MODEL: AU*A30L, AU*A36L

● Air flow volume - Static pressure of Fresh air intake characteristic

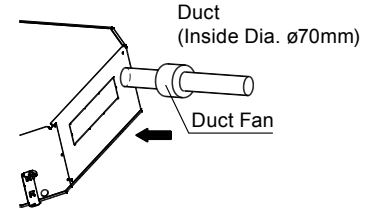
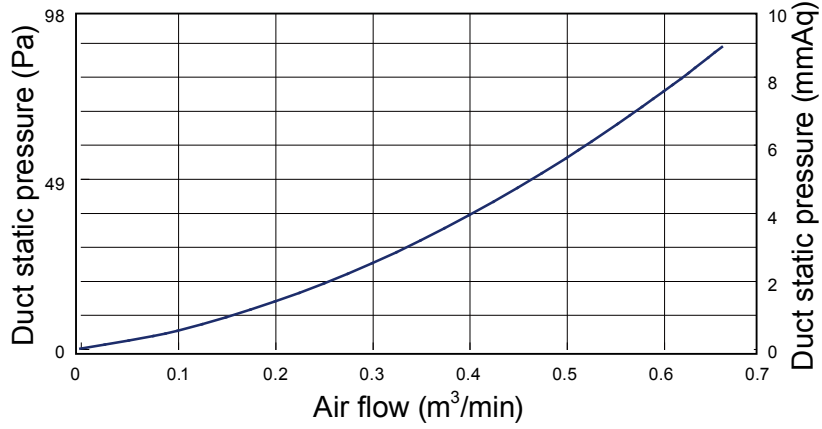

Static pressure required to take in fresh air

● Installation

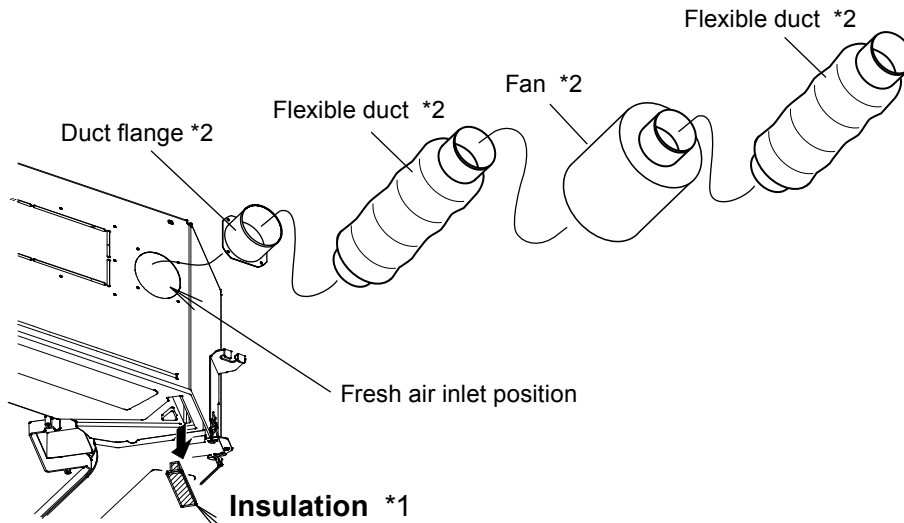
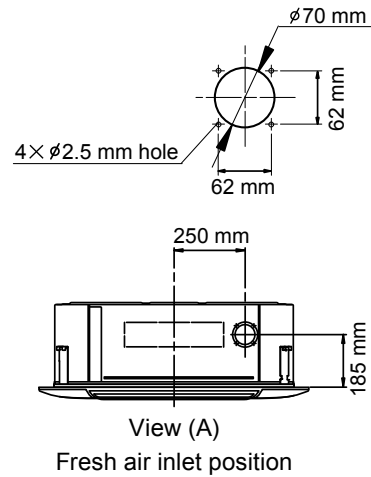
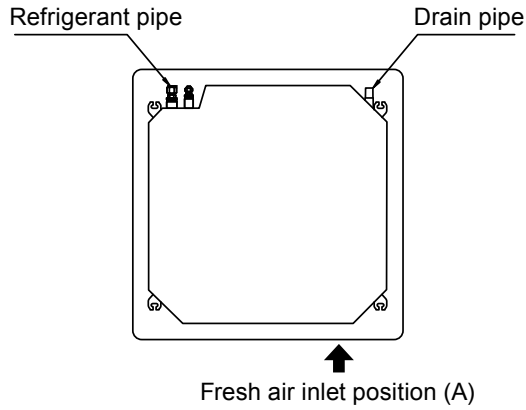

*1 : In case of fresh air intake, please remove the insulation.

*2 : Locally procured parts

7-4. DUCT CONNECTION

MODEL: AU*A30L, AU*A36L

● Outlet air

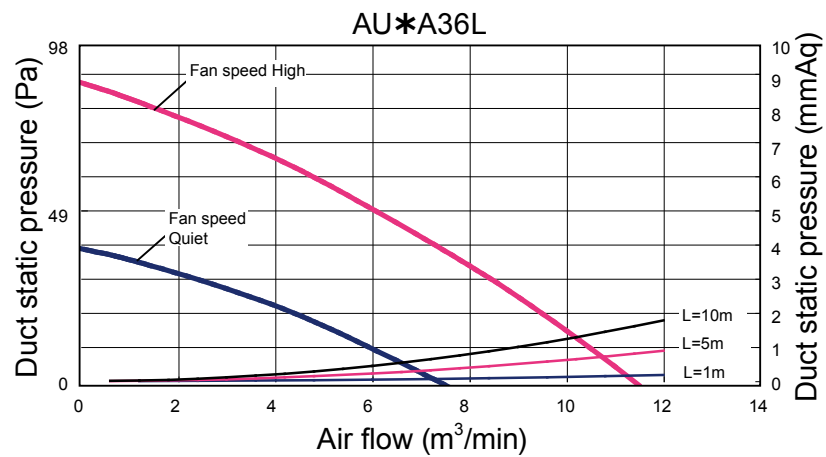
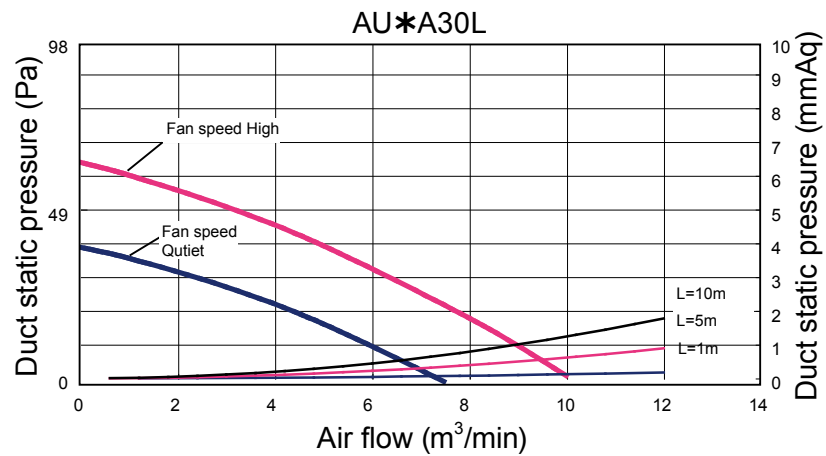
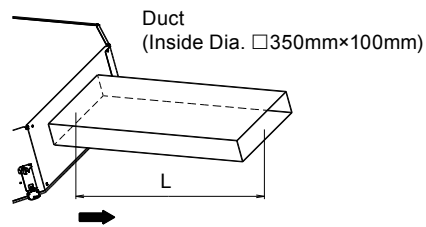

■ PRECAUTIONS WHILE CONNECTING AIR OUTLET DUCT

- Connect the air outlet duct at up to two locations among the four duct connection locations. (Do not connect ducts at three or more locations.)

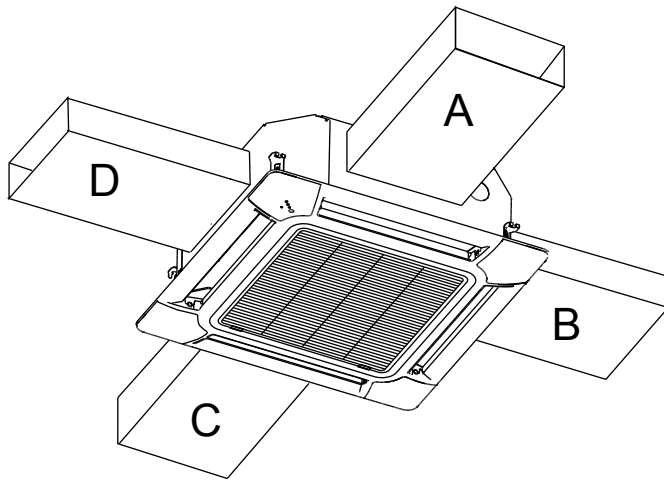

- Blow-off pattern when a branch duct is installed
Bi-directional branching, main unit bi-directional branching

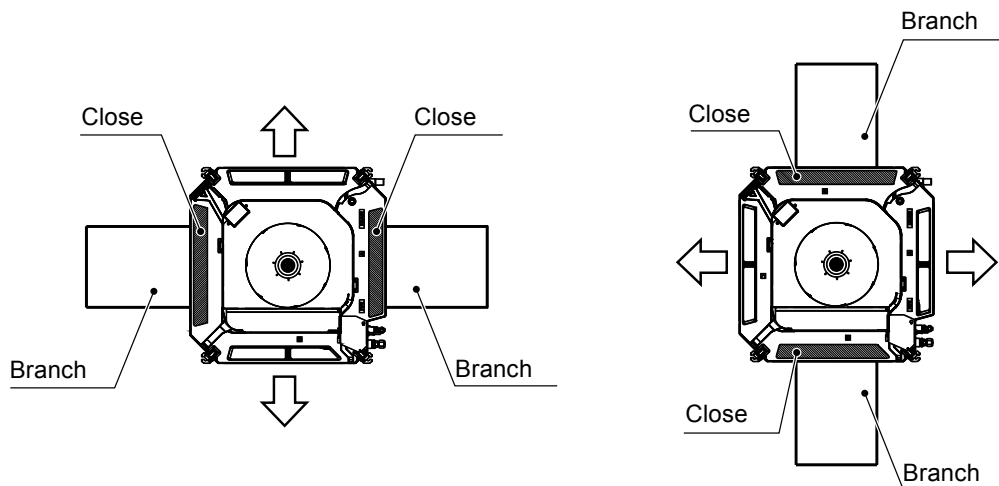

- Once the location where the duct is to be connected is decided, always be sure to close the outlets in the same direction.

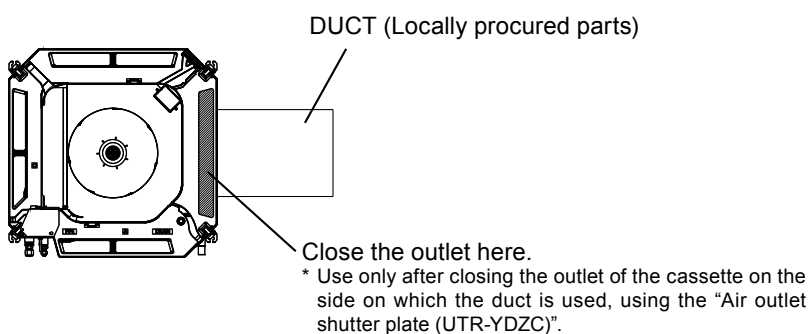

8. OPERATION NOISE

8-1. NOISE LEVEL CURVE

MODEL: AU*A30L

Condition
Ceiling mode : Standard
Air outlet : 4-way air outlet

● Cooling

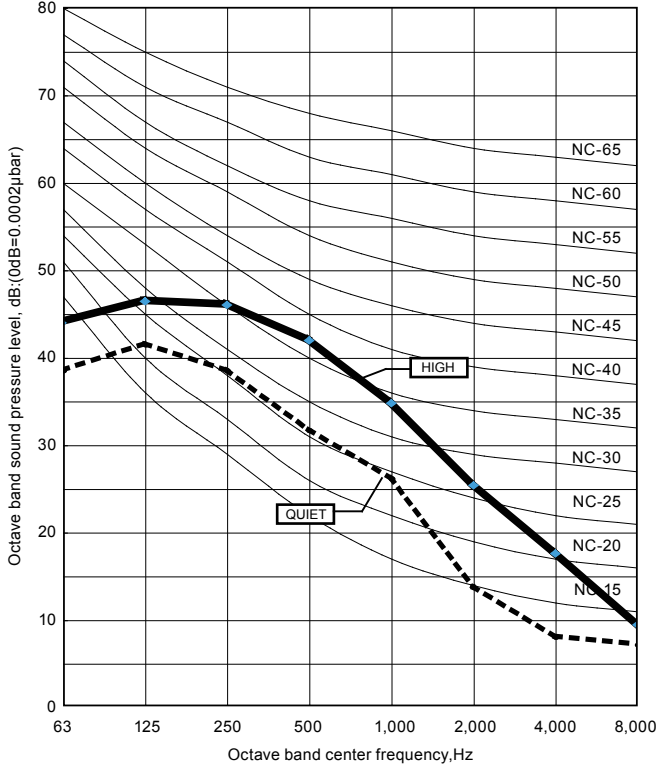

● Heating

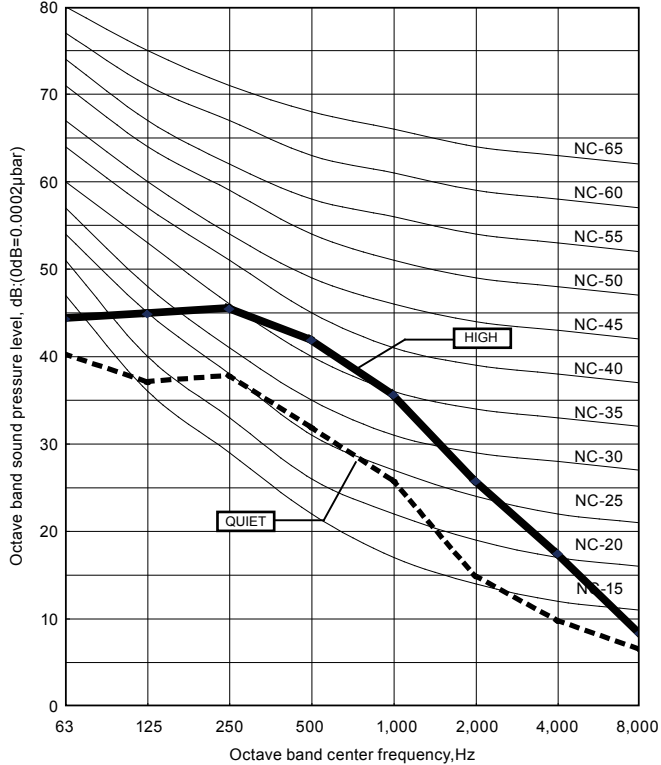

MODEL: AU*A36L

● Cooling

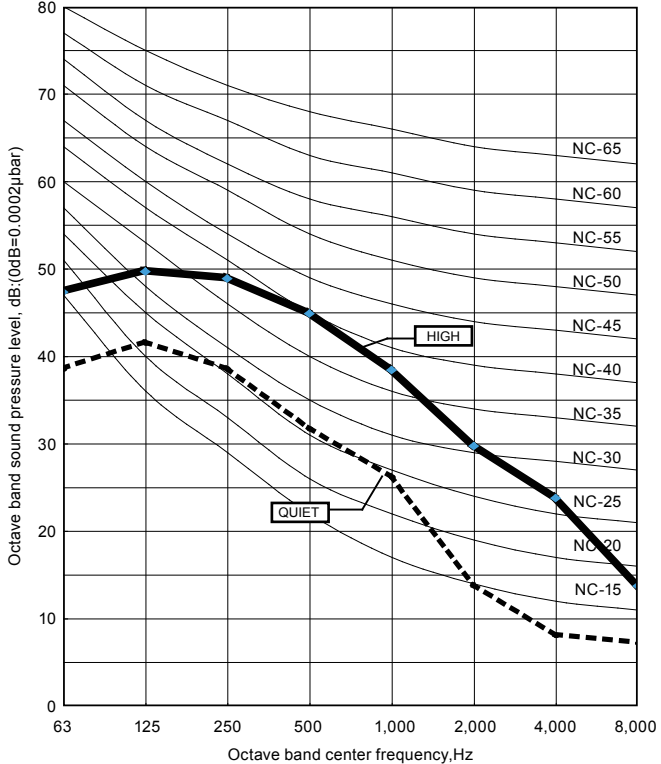

● Heating

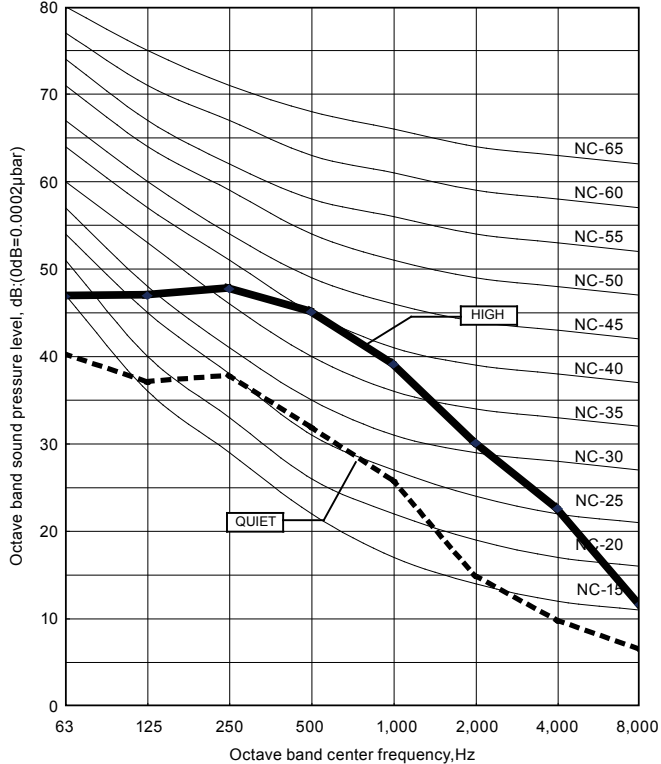

8-2. SOUND LEVEL CHECK POINT

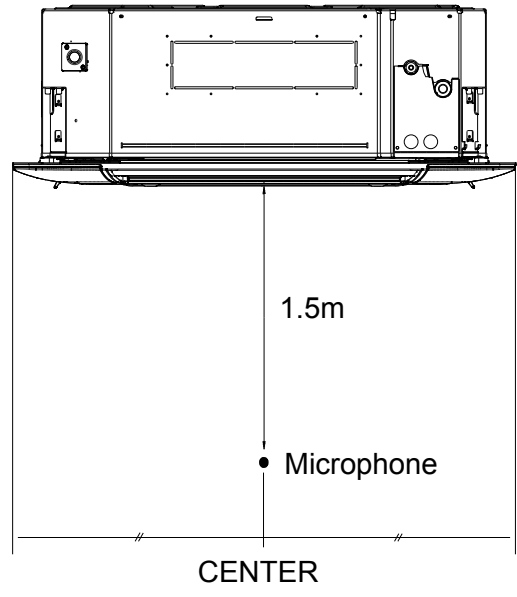
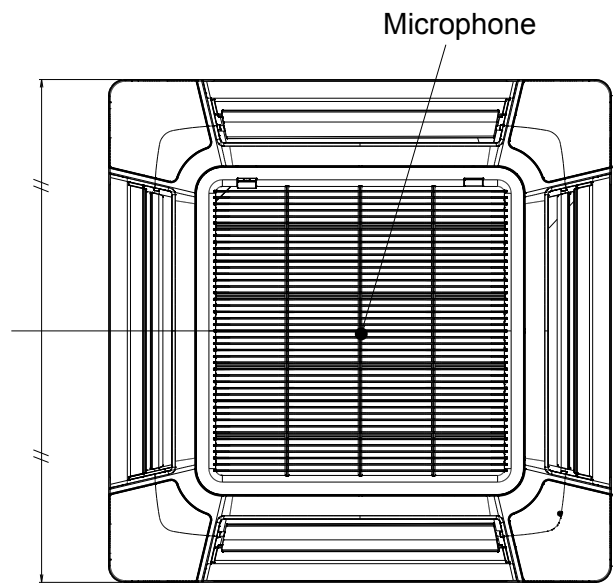

9. ELECTRIC CHARACTERISTICS

Model Name			AU*A30L	AU*A36L
Power Supply	Voltage	V	230 ~	
	Frequency	Hz	50	
Max Operating Current (Indoor unit)		A	0.7	
Wiring Spec. (Indoor unit to outdoor unit)	Connection Cable	mm ²	1.5-2.5	
	Limited wiring length	m	51	

10. SAFETY DEVICES

	Protection form	Model	
		AU*A30L	AU*A36L
Circuit protection	Current fuse (PCB)	3.15A 250V	
Fan motor protection	Thermal protection program	110±15°C OFF 105±15°C ON	

11. EXTERNAL INPUT & OUTPUT

Connector	INPUT	OUTPUT	REMARKS
CN102	Control input (Operation/Stop)	—	See external input/output settings for details.
CN103	—	Operation status output	
CN6	—	Fresh air control output	

11-1. EXTERNAL INPUT

■ CONTROL INPUT (Operation/Stop)

The air conditioner can be remotely operated by means of the following on-site work.

Operation is started at the following contents by adding the contact input of a commercial ON/OFF switch to a connector on the external control PC board and turning it ON.

	Initial starting after power turned on	Starting other than at the left
Operation mode	Auto changeover	Mode at previous operation
Set temperature	24°C	Temperature at previous operation
Air flow mode	AUTO	Mode at previous operation
Up-down air direction (swing)	Standard air direction (swing OFF)	Air direction at previous operation
Left-right air direction (swing)	Standard air direction (swing OFF)	Air direction at previous operation

● Circuit diagram example

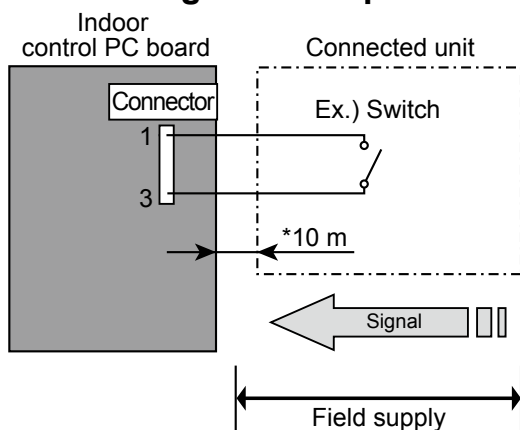

* Make the distance from the PC board to the connected unit within 10m.
Contact capacity : 12VDC or more, 15mA or more.
Please use the non-polar relays and switches.

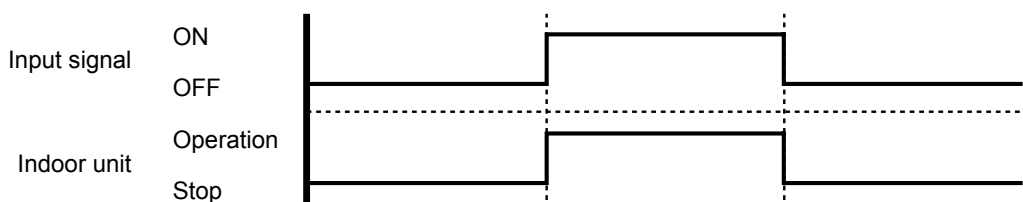

● Parts (Optional)

Model name
UTY-XWZX

Wire (External input)

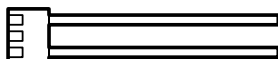

11-2. EXTERNAL OUTPUT

■ OPERATION STATUS OUTPUT

An air conditioner operation status signal can be output.

● Circuit diagram example

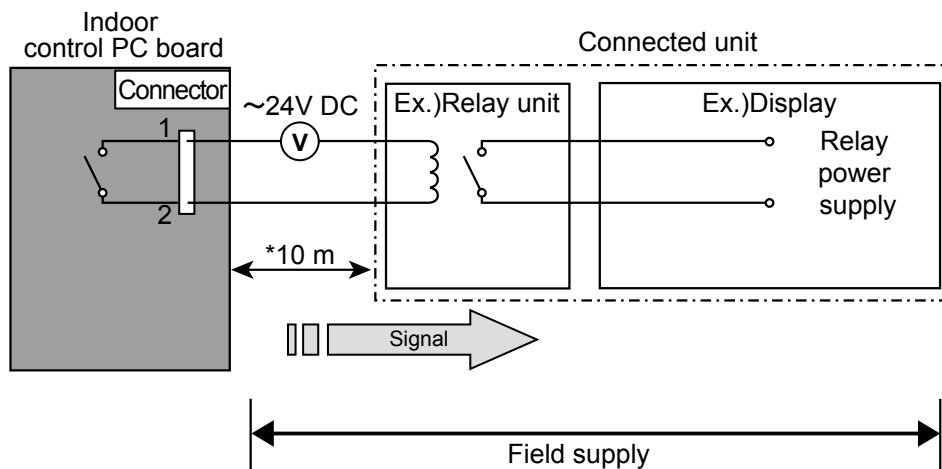

* Make the distance from the PC board to the connected unit within 10m.
Relay spec. : Max.24VDC, 10mA to less than 500mA.

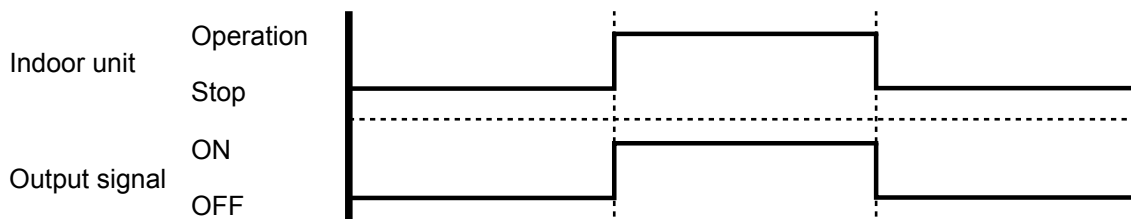

● Parts (Optional)

Model name
UTY-XWZX

Wire (External output)

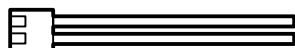

■ FRESH AIR CONTROL OUTPUT

A signal linked to air conditioner indoor fan ON can be output.

* However, signal becomes OFF during cold air prevention control operation.

● Circuit diagram example

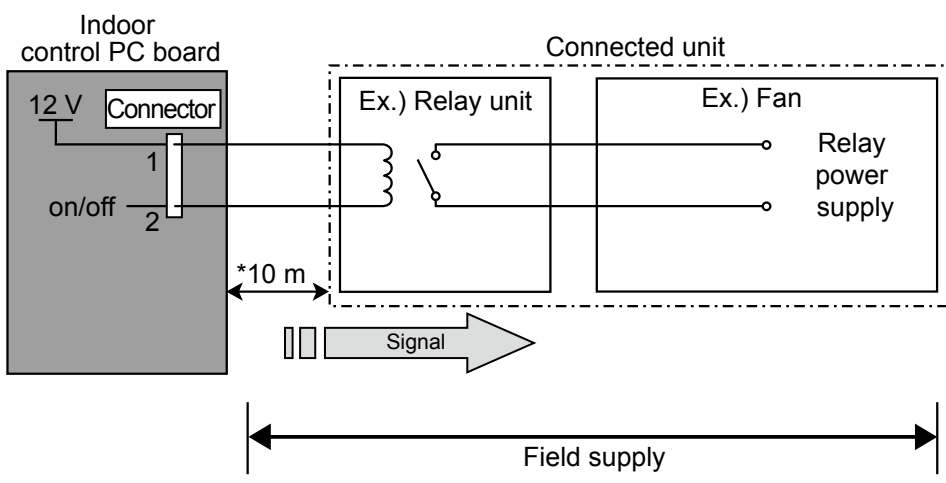

* Make the distance from the PC board to the connected unit within 10m.
Relay spec. : Rated 12VDC, 50mA or less.

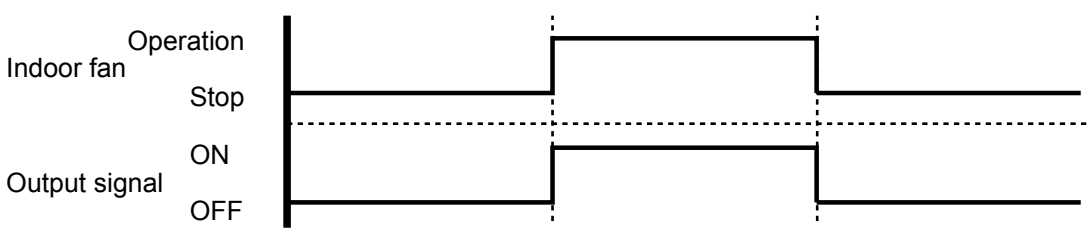

● Parts (Optional)

Model name
UTZ-VXGA *1

Wire (Fresh air output)



Note

*1: Please prepare External control set (UTD-ECS5A) when using it excluding Fresh air intake kit (UTZ-VXGA).

12. FUNCTION SETTING

12-1. INDOOR UNIT

INDOOR UNIT		
DIP SW	1	Setting forbidden
	2	
	3	
	4	
Jumper Wire	JM1	Remote control unit signal code
	JM2	
	JM3	Setting forbidden

■ SWITCH POSITION

MAIN PCB

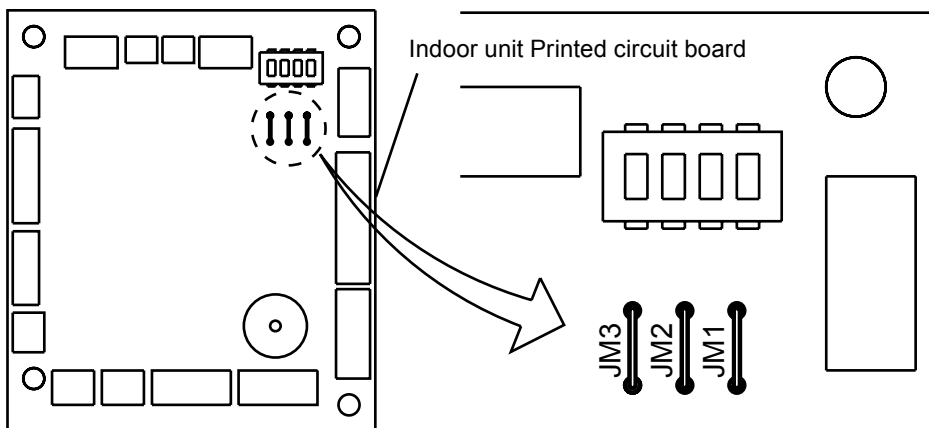

■ JUMPER WIRE SETTING

Remote control unit signal code

Indoor unit setting

(◆... Factory setting)

Jumper wire		Remote control unit signal code
JM 1	JM 2	
Connect	Connect	A ◆
Disconnect	Connect	B
Connect	Disconnect	C
Disconnect	Disconnect	D

12-2. WIRED REMOTE CONTROLLER

DIP SW	1	Can not be used. (Do not change)
	2	Dual remote controller setting
	3	Can not be used. (Do not change)
	4	Can not be used. (Do not change)
	5	Can not be used. (Do not change)
	6	Memory backup setting

SWITCH POSITION

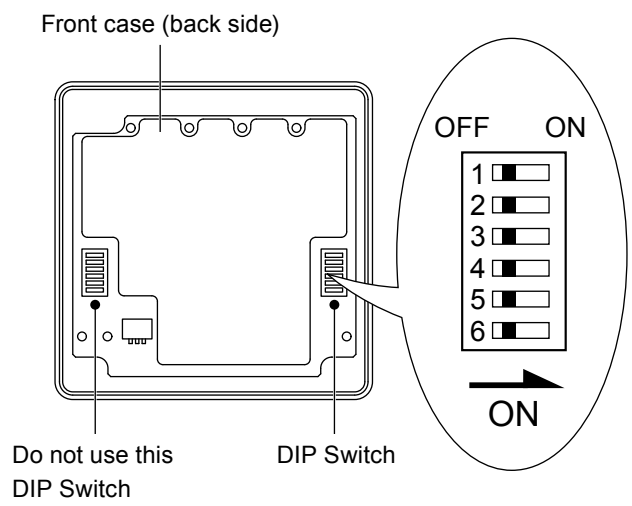

DIP SWITCH SETTING

1. Dual remote controller setting

Set the remote controller DIP switch No.2 according to the following table.

(◆... Factory setting)

Number of remote controller	Master unit	Slave unit
	DIP-SW No.2	DIP-SW No.2
◆ 1 (Normal)	OFF	—
2 (Dual)	OFF	ON

2. Memory backup setting

Set to ON to use batteries for the memory backup. If batteries are not used, all of the settings stored in memory will be deleted if there is a power failure.

(◆... Factory setting)

DIP-SW No.6	Memory backup
◆ OFF	Invalidity
ON	Validity

⚠ CAUTION

- Confirm whether the wiring work for outdoor unit has been finished.
- Confirm whether the cover for electric control box on the outdoor unit is close.

1. Turning on the power

- (1) Check the remote controller wiring and DIP switch settings.
- (2) Install the front case.
When installing the front case, connect the connector to the front case.
- (3) Check the indoor and outdoor unit wiring and circuit board switch settings, and then turn on the indoor and outdoor units. After "8C" has flashed on the set temperature display for several seconds, the clock display will appear in the center of the remote controller display.
The clock display will appear in the center of the remote controller display.

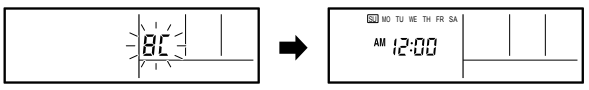

2. Function setting

- This procedure changes to the function settings used to control the indoor unit according to the installation conditions. Incorrect settings can cause the indoor unit malfunction.
- After the power is turned on, perform the "FUNCTION SETTING" according to the installation conditions using the remote controller.
- The settings may be selected between the following two: Function Number or Setting Value.
- Settings will not be changed if invalid numbers or setting values are selected.

Operation Method

- (1) Press the set temperature buttons (▽) (△) and fan control button simultaneously for more than 5 seconds to enter the function setting mode.

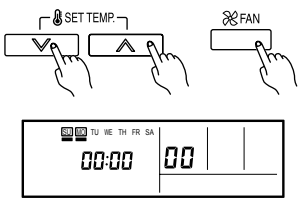

- (2) Press the SET BACK button to select the indoor unit number.

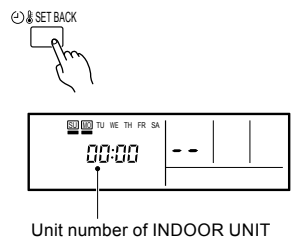

- (3) Press the set time buttons to select the function number.

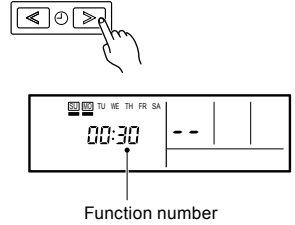

- (4) Press the set temperature buttons (▽) (△) to select the setting value.
The display flashes as shown to the right during setting value selection.

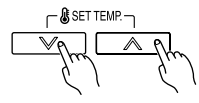

- (5) Press the TIMER SET button to confirm the setting. Press the TIMER SET button for a few seconds until the setting value stops flashing.
If the setting value display changes or if "-" is displayed when the flashing stops, the setting value has not been set correctly. (An invalid setting value may have been selected for the indoor unit.)

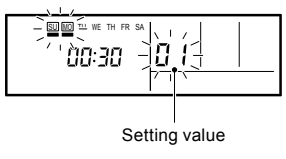

- (6) Repeat steps 2 to 5 to perform additional settings. Press the set temperature buttons (▽) (△) and fan control button simultaneously again for more than 5 seconds to cancel the function setting mode. In addition, the function setting mode will be automatically canceled after 1 minute if no operation is performed.
- (7) After completing the FUNCTION SETTING, be sure to turn off the power and turn it on again.

Setting the Ceiling Height

- Select the setting values in the table below according to the height of the ceiling. (The unit is factory-set to "00".)

Setting Description [m]	Function Number	Setting Value
Standard 3.2m	20	00
Low ceiling 2.7m		01
High ceiling 3.6m (30 model) 4.2m (36 model)		02

The ceiling height values are for the 4-way outlet.
Do not change this setting in the 3-way outlet mode.

Setting the vertical direction adjusting scope

- To prevent from draft, we recommend using "upward mode". (The unit is factory-set to "00".)

Setting Description	Function Number	Setting Value
Standard	23	00
Upward		01

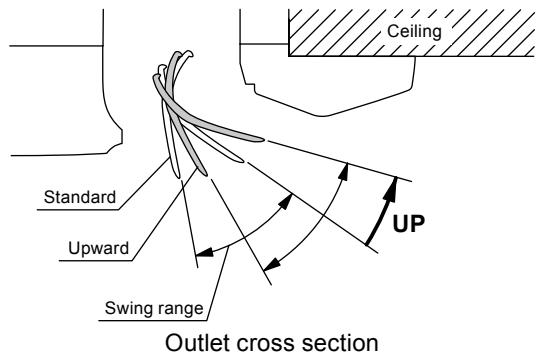

Setting the Outlet Directions

- Select the setting values in the table below for using a 3-way outlet. (The unit is factory-set to "00".)

Setting Description	Function Number	Setting Value
4-way	22	00
3-way		01

Setting the Filter Sign

- The indoor unit has a sign to inform the user that it is time to clean the filter.
- Select the time setting for the filter sign display interval in the table below according to the amount of dust or debris in the room. (The unit is factory-set to "00".)
- If you do not wish the filter sign to be displayed, select the setting value for "No indication".

Setting Description	Function Number	Setting Value
Standard (2,500 hours)	11	00
Long interval (4,400 hours)		01
Short interval (1,250 hours)		02
No indication		03

Setting the Cooler Room Temperature Correction

- Depending on the installed environment, the room temperature sensor may require a correction. The settings may be selected as shown in the table below. (The unit is factory-set to "00".)

Setting Description	Function Number	Setting Value
Standard	30	00
Lower control		01

Setting the Heater Room Temperature Correction

- Depending on the installed environment, the room temperature sensor may require a correction. The settings may be changed as shown in the table below. (The unit is factoryset to "00".)

Setting Description	Function Number	Setting Value
Standard	31	00
Lower control		01
Slightly warmer control		02
Warmer control		03

Setting Other Functions

- The following settings are also possible, depending on the operating conditions. (The unit is factory-set to "00".)

Auto Restart

Setting Description	Function Number	Setting Value
Yes	40	00
No		01

Indoor Room Temperature Sensor Switching Function (Wired remote controller only)

Setting Description	Function Number	Setting Value
No	42	00
Yes		01

- If setting value is "00", room temperature is controlled by the indoor unit temperature sensor.
- If setting value is "01", room temperature is controlled by either indoor unit temperature sensor or remote control unit sensor.

Setting record

- Record any changes to the settings in the following table.

Setting	Setting Value
Ceiling height	
Vertical direction adjusting scope	
Outlet directions	
Filter sign	
Cooler room temperature correction	
Heater room temperature correction	
Auto restart	
Indoor room temperature sensor switching function	

After completing the FUNCTION SETTING, be sure to turn off the power and turn it on again.

3. Setting the room temperature detection location

The detection location of the room temperature can be selected from the following two examples. Choose the detection location that is best for the installation location.

A. Indoor unit setting (factory setting)

The room temperature is detected by the indoor unit temperature sensor.

- When the THERMO SENSOR button is pressed, the lock display flashes because the function is locked at the factory.

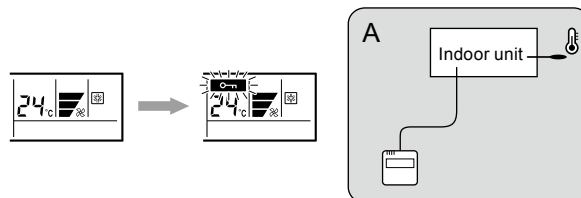

B. Indoor unit/remote controller setting (room temperature sensor selection)

The temperature sensor of the indoor unit or the remote controller can be used to detect the room temperature.

- Enable the room temperature sensor selection in FUNCTION SETTING, which will be described later.
- Press the THERMO SENSOR button for 5 seconds or more to select the temperature sensor of the indoor unit or the remote controller.

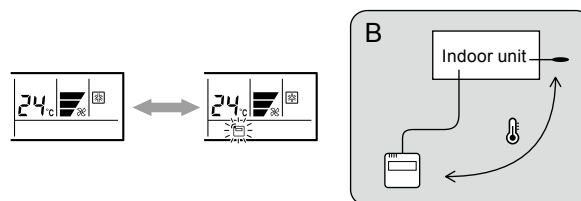





NOTE

If the function to change the temperature sensor is used as shown in examples A (other than example B), be sure to lock the detection location.

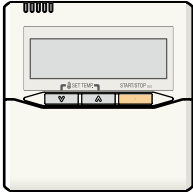
If the function is locked, the lock display will flash when the THERMO SENSOR button is pressed.

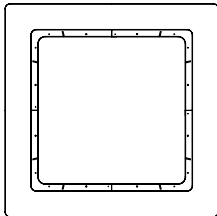
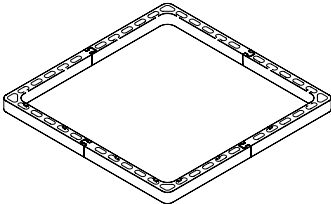
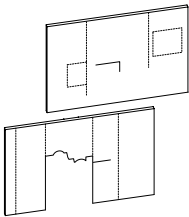
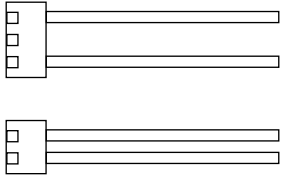
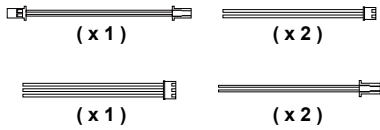
13. OPTIONAL PARTS

Exterior	Parts name	Model No.	Summary
	Wired remote controller	UTB-＊UD	Unit control is performed by wired remote controller. Wired remote controller is attached in one as accessories. Wired remote controller is two installation possibility in one indoor unit.
	IR Receiver kit	UTY-LRH＊A1	Unit control is performed by wireless remote controller
	Air outlet shutter plate	UTR-YDZC	Air outlet shutter plate is installed at the air outlet when 3-way direction is performed.
	Wide panel	UTG-AGYA-W	Wide panel hides the gap between the ceiling hole and the Decoration panel.
	Panel spacer	UTG-BGYA-W	Installation in a space of 256mm or greater is possible by using panel spacer when the height behind the ceiling is low. (Normal behind the ceiling installation height is 298mm.)
	Insulation kit for high humidity	UTZ-KXGA	Install when the under roof condition is expected to be the humidity of over 80% and the temperature of over 30 °C
	External connect kit	UTY-XWZX	Use to connect with various peripheral devices and air conditioner PC board.
	External control set	UTD-ECS5A	Use to connect with various peripheral devices and air conditioner PC board. (Set of 6)

Exterior	Parts name	Model No.	Summary
	Fresh air intake kit	UTZ-VXGA	It can be taken in fresh air of up to 10% of "high" air volume of the indoor unit by attaching Fresh Air Intake Kit to cassette type indoor unit.

2. OUTDOOR UNIT

SINGLE TYPE :

AO*A30LBTL

AO*A36LBTL

AO*A30LFTL

AO*A36LFTL

CONTENTS

2. OUTDOOR UNIT

1. SPECIFICATIONS.....	02 - 01
2. DIMENSIONS	02 - 03
3. REFRIGERANT CIRCUIT	02 - 04
4. WIRING DIAGRAMS.....	02 - 06
5. CAPACITY COMPENSATION RATE FOR PIPE LENGTH AND HEIGHT DEFFERENCE	02 - 09
6. ADDITIONAL CHARGE CALCULATION.....	02 - 11
7. AIR FLOW.....	02 - 12
8. OPERATION NOISE.....	02 - 14
8-1. NOISE LEVEL CURVE	02 - 14
8-2. SOUND LEVEL CHECK POINT.....	02 - 15
9. ELECTRIC CHARACTERISTICS.....	02 - 16
10. SAFETY DEVICES	02 - 17

1. SPECIFICATIONS

Type			INVERTER HEATPUMP	
Model name			AO*A30LBTL	AO*A36LBTL
Power source			230V ~ 50Hz	
Available voltage range			198-264V ~ 50Hz	
Starting current			A	15.0
Fan	Airflow rate	Cooling	m ³ /h	3600
		Heating		4000
	Type × Q'ty		Propeller × 1	
	Motor output		W	103
Sound pressure level	Cooling		dB(A)	53
	Heating			55
Heat exchanger type	Dimensions (H × W × D)		mm	798 × 900 × 36.4
	Fin pitch			1.30
	Rows x Stages		2 × 38	2 × 38
	Pipe type		Copper	
	Fin type		Aluminium	
Compressor	Type × Q'ty		Twin Rotary × 1	
	Motor output		W	1700
Refrigerant	Type		R410A	
	Charge	g	2100	
Refrigerant oil	Type		PVE	
Enclosure	Material		Steel sheet	
	Colour		BEIGE Approximate colour of MUNSELL 10YR 7.5/1.0	
Dimensions (H×W×D)	Net		mm	830 × 900 × 330
	Gross			970 × 1050 × 445
Weight	Net		kg (lb.)	62 (136)
	Gross			70 (154)
Connection pipe	Size	Liquid	mm	Ø 9.52 (Ø 3/8 in.)
		Gas		Ø 15.88 (Ø 5/8 in.)
	Method		Flare	
	Pre-charge length		m	20
	Max. length			50
Max. height difference		30		
Operation range	Cooling		°C	-15 to 46
	Heating			-15 to 24

Note :

Specifications are based on the following conditions.

Cooling : Indoor temperature of 27 °CDB / 19 °CWB.and outdoor temperature of 35 °CDB/24 °CWB.

Heating : Indoor temperature of 20 °CDB / 15 °CWB.and outdoor temperature of 7 °CDB/6 °CWB.

Pipe length : 5 m, Height difference : 0 m.(Outdoor unit - Indoor unit)

Type			INVERTER HEATPUMP	
Model name			AO*A30LFTL	AO*A36LFTL
Power source			230V ~ 50Hz	
Available voltage range			198-264V ~ 50Hz	
Starting current			A	15.0
Fan	Airflow rate	Cooling	m ³ /h	3600
		Heating		3600
	Type × Q'ty		Propeller × 1	
	Motor output		W	100
Sound pressure level	Cooling		dB(A)	53
	Heating			55
Heat exchanger type	Dimensions (H × W × D)		mm	798 × 900 × 36.4
	Fin pitch			1.30
	Rows x Stages		2 × 38	2 × 38
	Pipe type		Copper	
	Fin type		Aluminium	
Compressor	Type × Q'ty		Twin Rotary × 1	
	Motor output		W	2100
Refrigerant	Type		R410A	
	Charge	g	2100	
Refrigerant oil	Type		POE (RB68)	
Enclosure	Material		Steel sheet	
	Colour		BEIGE Approximate colour of MUNSELL 10YR 7.5/1.0	
Dimensions (H×W×D)	Net		mm	830 × 900 × 330
	Gross			970 × 1050 × 445
Weight	Net		kg (lb.)	61 (135)
	Gross			68 (150)
Connection pipe	Size	Liquid	mm	Ø 9.52 (Ø 3/8 in.)
		Gas		Ø 15.88 (Ø 5/8 in.)
	Method		Flare	
	Pre-charge length		m	20
	Max. length			50
	Max. height difference			30
Operation range	Cooling		°C	-15 to 46
	Heating			-15 to 24

Note :

Specifications are based on the following conditions.

Cooling : Indoor temperature of 27 °CDB / 19 °CWB.and outdoor temperature of 35 °CDB/24 °CWB.

Heating : Indoor temperature of 20 °CDB / 15 °CWB.and outdoor temperature of 7 °CDB/6 °CWB.

Pipe length : 5 m, Height difference : 0 m.(Outdoor unit - Indoor unit)

2. DIMENSIONS

■ MODEL: AO*A30LB, AO*A36LB, AO*A30LF, AO*A36LF

(Unit : mm)

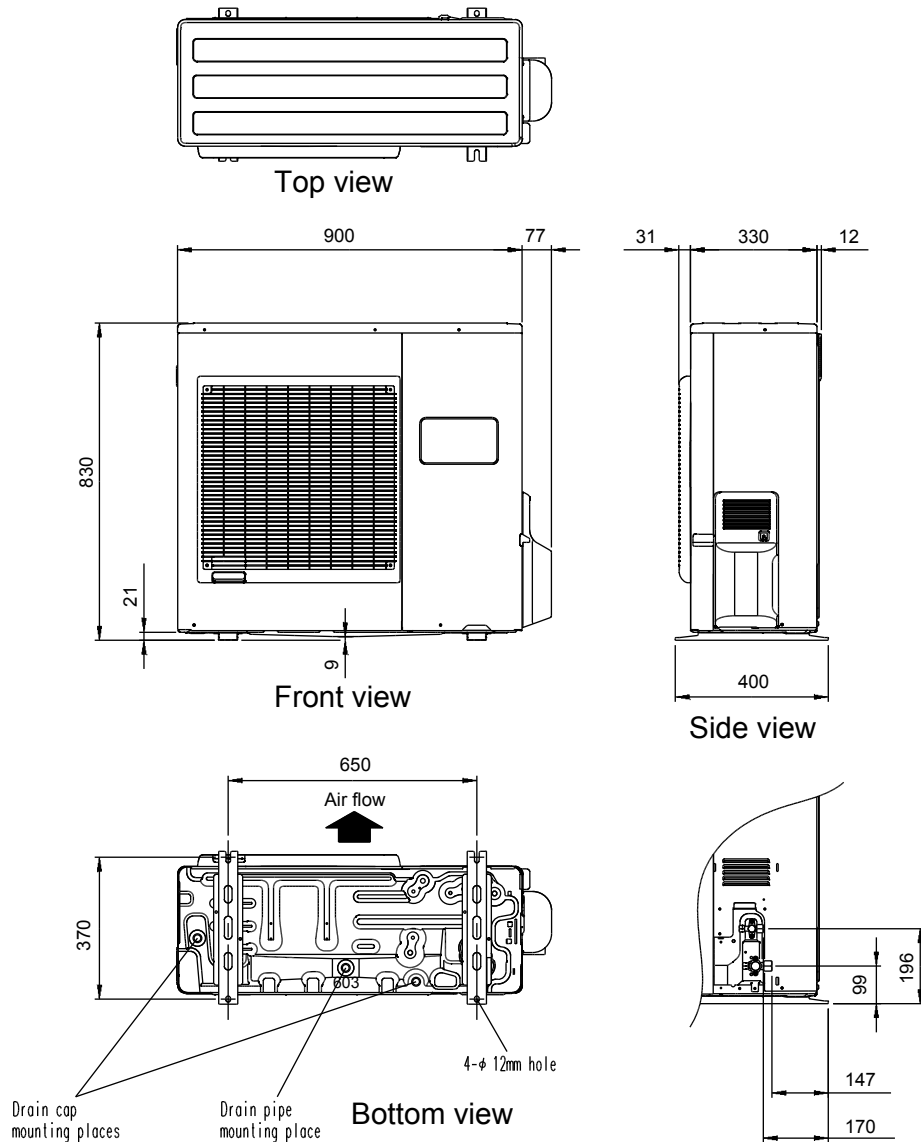

■ INSTALLATION PLACE

When there are obstacles at the back or front sides.

When there are obstacles at the back, side(s), and top.

When there are obstacles at the back, side with the installation of more than one unit.

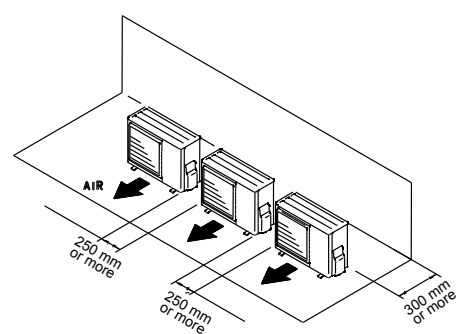
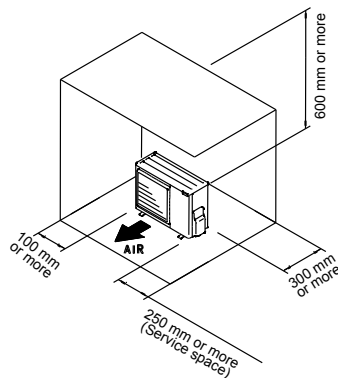
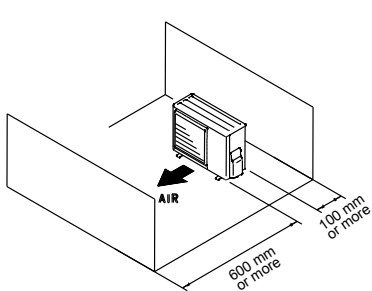

3. REFRIGERANT CIRCUIT

■ MODEL: AO*A30LB, AO*A36LB

OUTDOOR UNIT
AO*A30-36L

OUTDOOR UNIT
AO*A30-36L

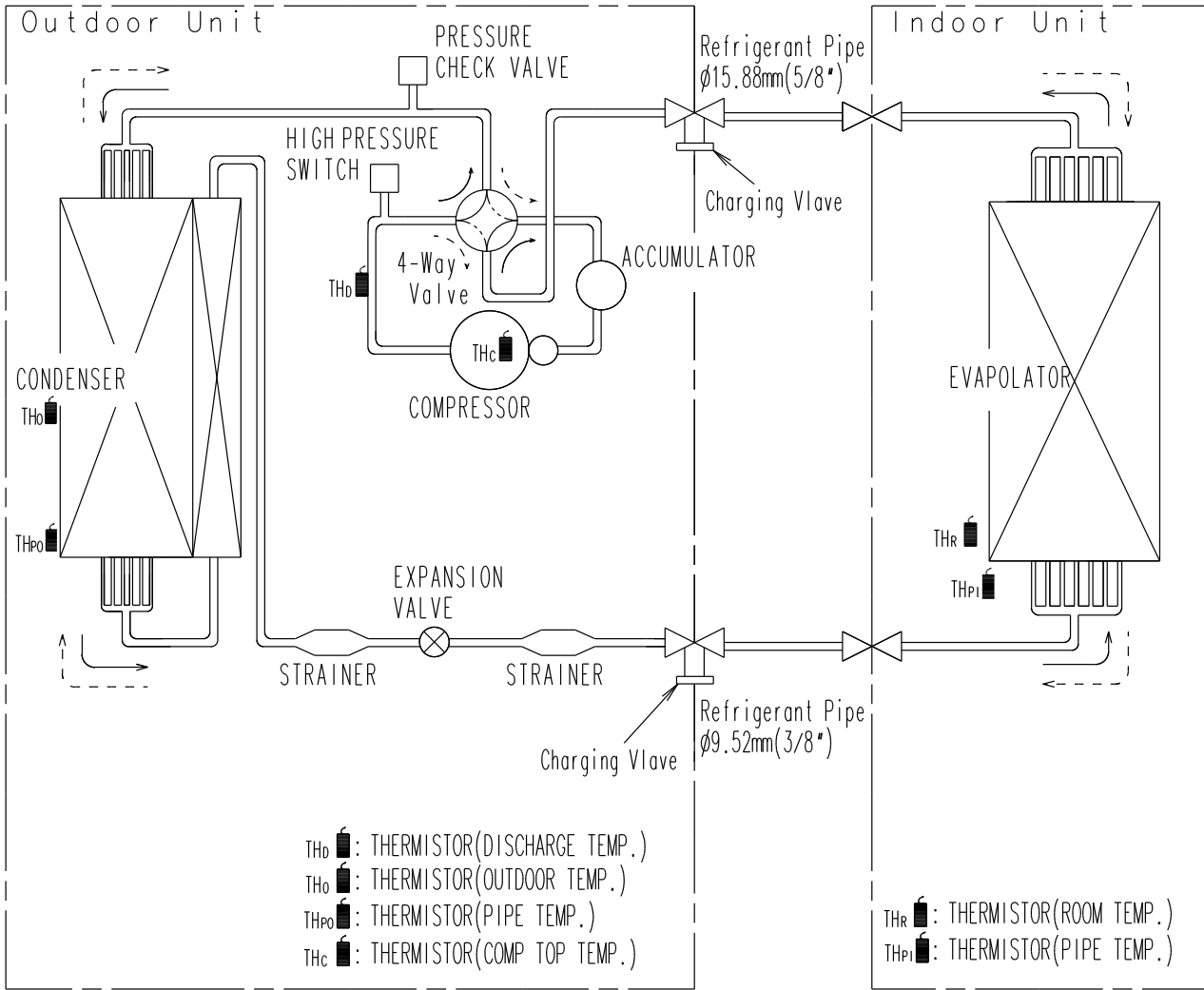

■ MODEL: AO*A30LF, AO*A36LF

OUTDOOR UNIT
AO*A30-36L

OUTDOOR UNIT
AO*A30-36L

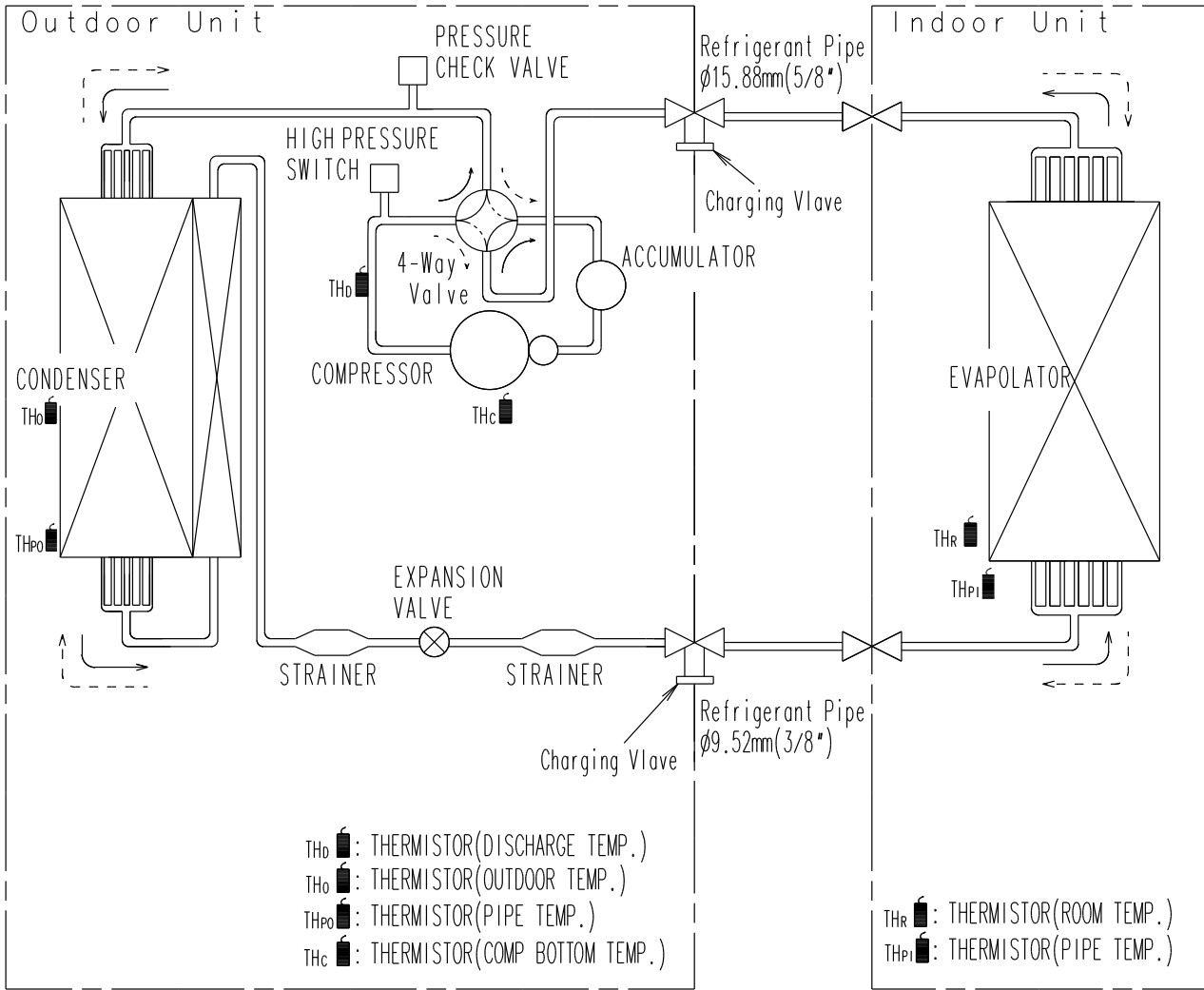

4. WIRING DIAGRAMS

MODEL: AO*A30LB, AO*A36LB

OUTDOOR UNIT
AO*A30-36L

OUTDOOR UNIT
AO*A30-36L

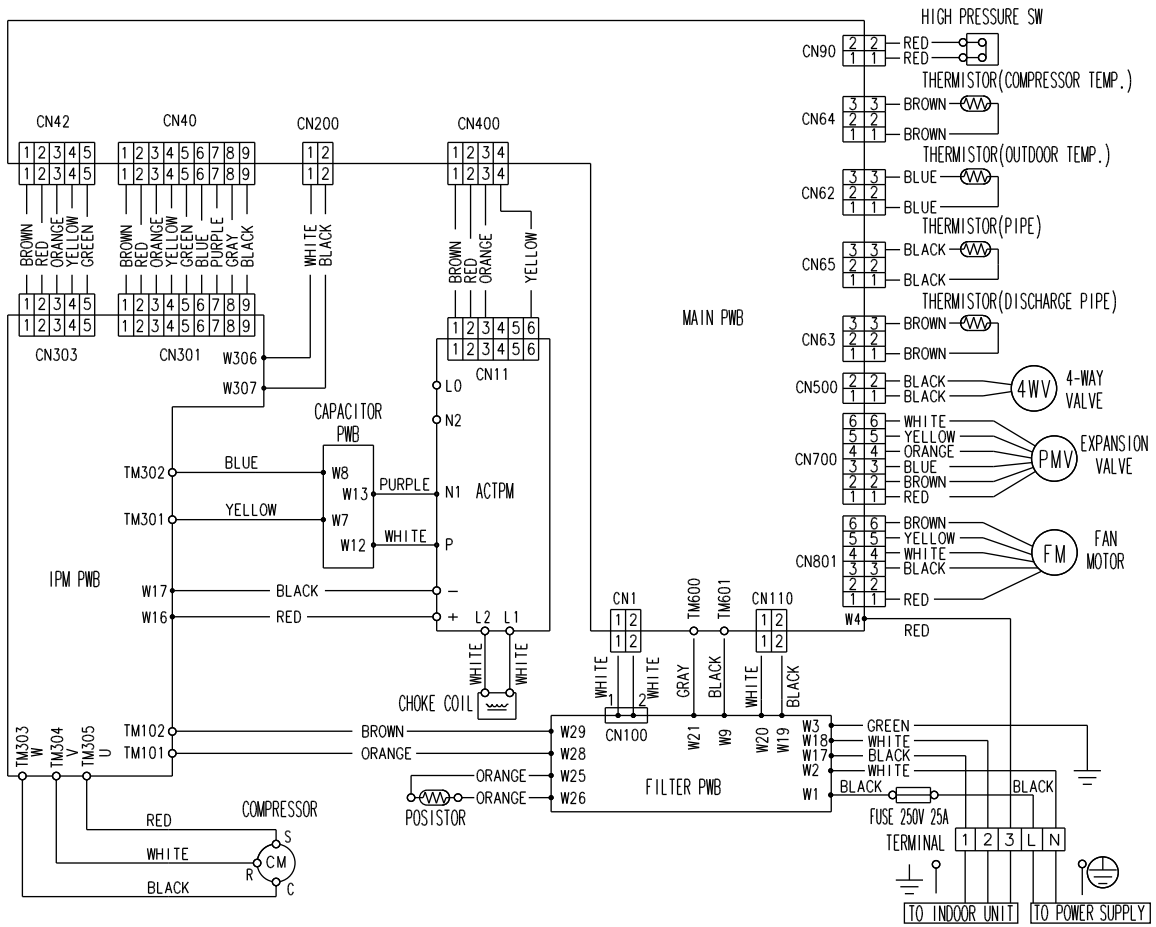

MODEL: AO*A30LF

OUTDOOR UNIT
AO*A30-36L

OUTDOOR UNIT
AO*A30-36L

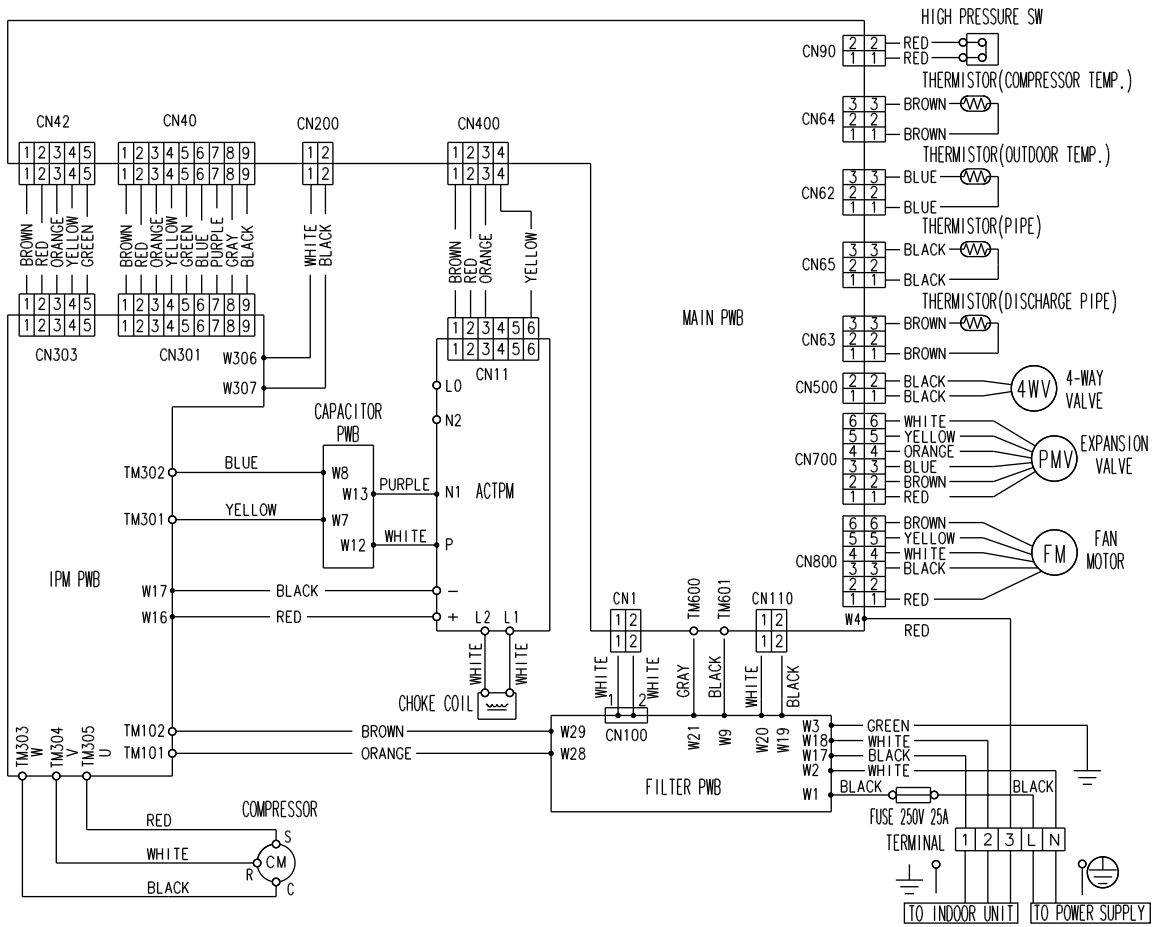

MODEL: AO*A36LF

OUTDOOR UNIT
AO*A30-36L

OUTDOOR UNIT
AO*A30-36L

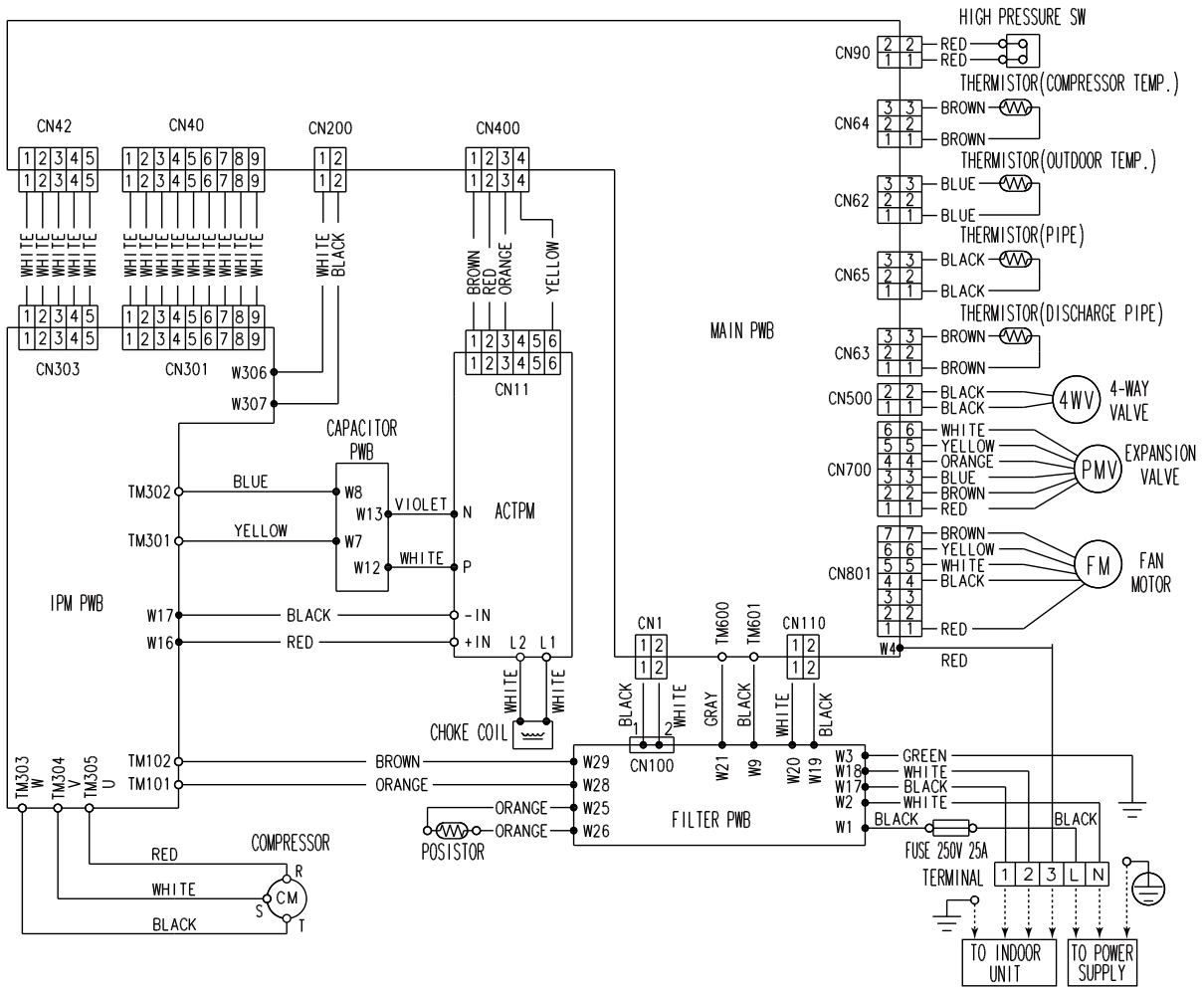

5. CAPACITY COMPENSATION RATE FOR PIPE LENGTH AND HEIGHT DIFFERENCE

This table is created using the maximum capacity.

OUTDOOR UNIT
AO*A30-36L

OUTDOOR UNIT
AO*A30-36L

MODEL: AO*A30LB, AO*A30LF

COOLING			Pipe length (m)						
			5	7.5	10	20	30	40	50
Height difference H (m)	*1 Indoor unit is upper than outdoor unit	30	-	-	-	-	0.908	0.894	0.876
		20	-	-	-	0.935	0.923	0.909	0.891
		10	-	-	0.968	0.951	0.938	0.924	0.906
		7.5	-	0.982	0.972	0.954	0.942	0.928	0.909
		5	0.992	0.986	0.976	0.958	0.946	0.932	0.913
	0	1.000	0.994	0.983	0.966	0.954	0.939	0.920	
	*2 Indoor unit is under than outdoor unit	-5	1.000	0.994	0.983	0.966	0.954	0.939	0.920
		-7.5	-	0.994	0.983	0.966	0.954	0.939	0.920
		-10	-	-	0.983	0.966	0.954	0.939	0.920
		-20	-	-	-	0.966	0.954	0.939	0.920
-30		-	-	-	-	0.954	0.939	0.920	

HEATING			Pipe length (m)						
			5	7.5	10	20	30	40	50
Height difference H (m)	*1 Indoor unit is upper than outdoor unit	30	-	-	-	-	0.931	0.914	0.899
		20	-	-	-	0.954	0.931	0.914	0.899
		10	-	-	0.990	0.954	0.931	0.914	0.899
		7.5	-	0.991	0.990	0.954	0.931	0.914	0.899
		5	1.000	0.991	0.990	0.954	0.931	0.914	0.899
	0	1.000	0.991	0.990	0.954	0.931	0.914	0.899	
	*2 Indoor unit is under than outdoor unit	-5	0.995	0.986	0.986	0.949	0.926	0.909	0.895
		-7.5	-	0.983	0.983	0.946	0.924	0.907	0.892
		-10	-	-	0.981	0.944	0.921	0.904	0.890
		-20	-	-	-	0.935	0.912	0.895	0.881
-30		-	-	-	-	0.903	0.886	0.872	

Height difference H

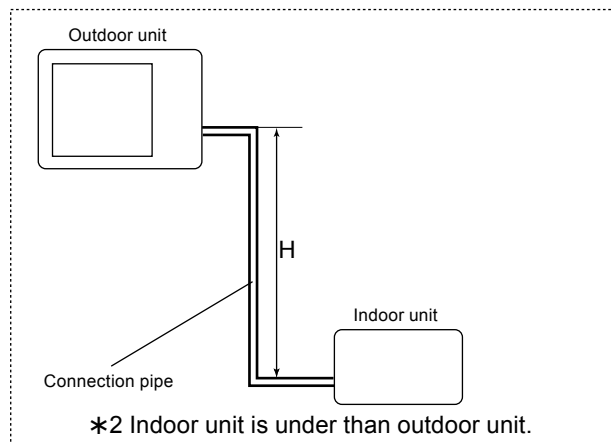
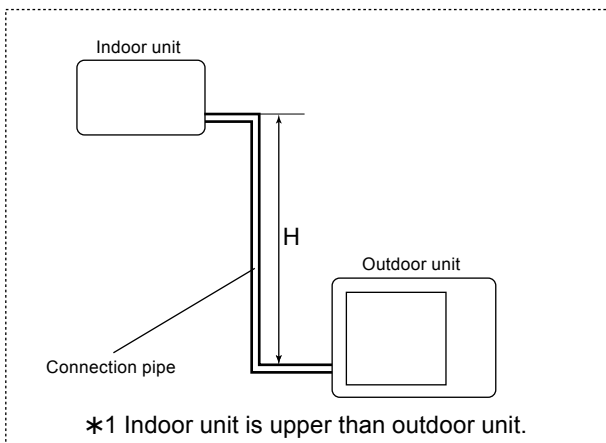

This table is created using the maximum capacity.

MODEL: AO*A36LB, AO*A36LF

COOLING			Pipe length (m)						
			5	7.5	10	20	30	40	50
Height difference H (m)	*1 Indoor unit is upper than outdoor unit	30	-	-	-	-	0.908	0.894	0.876
		20	-	-	-	0.935	0.923	0.909	0.891
		10	-	-	0.968	0.951	0.938	0.924	0.906
		7.5	-	0.982	0.972	0.954	0.942	0.928	0.909
		5	0.992	0.986	0.976	0.958	0.946	0.932	0.913
	0	1.000	0.994	0.983	0.966	0.954	0.939	0.920	
	*2 Indoor unit is under than outdoor unit	-5	1.000	0.994	0.983	0.966	0.954	0.939	0.920
		-7.5	-	0.994	0.983	0.966	0.954	0.939	0.920
		-10	-	-	0.983	0.966	0.954	0.939	0.920
		-20	-	-	-	0.966	0.954	0.939	0.920
-30		-	-	-	-	0.954	0.939	0.920	

HEATING			Pipe length (m)						
			5	7.5	10	20	30	40	50
Height difference H (m)	*1 Indoor unit is upper than outdoor unit	30	-	-	-	-	0.931	0.914	0.899
		20	-	-	-	0.954	0.931	0.914	0.899
		10	-	-	0.990	0.954	0.931	0.914	0.899
		7.5	-	0.991	0.990	0.954	0.931	0.914	0.899
		5	1.000	0.991	0.990	0.954	0.931	0.914	0.899
	0	1.000	0.991	0.990	0.954	0.931	0.914	0.899	
	*2 Indoor unit is under than outdoor unit	-5	0.995	0.986	0.986	0.949	0.926	0.909	0.895
		-7.5	-	0.983	0.983	0.946	0.924	0.907	0.892
		-10	-	-	0.981	0.944	0.921	0.904	0.890
		-20	-	-	-	0.935	0.912	0.895	0.881
-30		-	-	-	-	0.903	0.886	0.872	

Height difference H

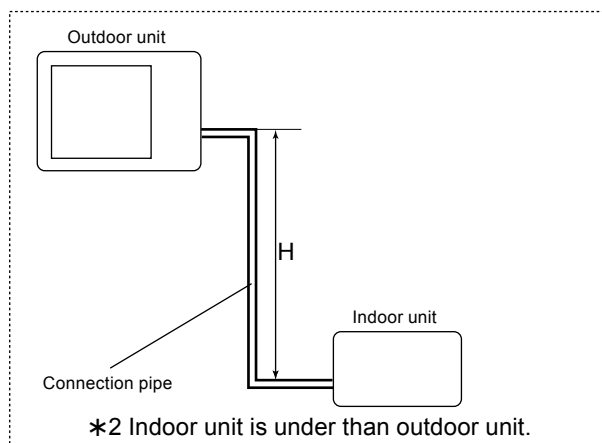
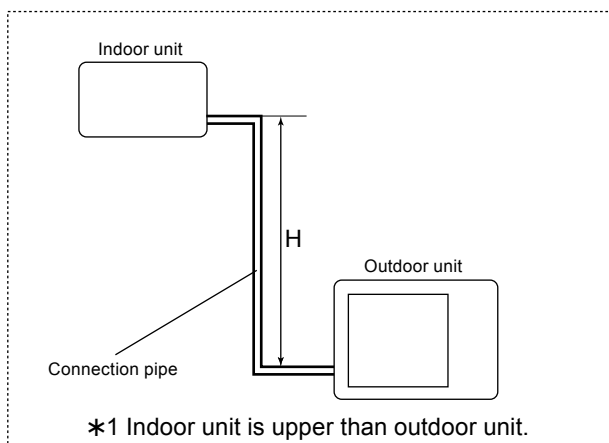

6. ADDITIONAL CHARGE CALCULATION

■ MODEL: AO*A30LB, AO*A36LB, AO*A30LF, AO*A36LF

Refrigerant type		R410A
Refrigerant amount	g	2100

● REFRIGERANT CHARGE

Pipe length	m	20 or less	30	40	50	40g/m
Additional charge	g	0	+400	+800	+1200	

7. AIR FLOW

■ MODEL: AO*A30LB

● COOLING

Number of rotations (r.p.m)	Air flow	
	850	m ³ /h
l/s		1000
CFM		2119

● HEATING

Number of rotations (r.p.m)	Air flow	
	900	m ³ /h
l/s		1056
CFM		2236

■ MODEL: AO*A36LB

● COOLING

Number of rotations (r.p.m)	Air flow	
	950	m ³ /h
l/s		1111
CFM		2354

● HEATING

Number of rotations (r.p.m)	Air flow	
	900	m ³ /h
l/s		1056
CFM		2236

■ **MODEL: AO*A30LF**

● **COOLING**

Number of rotations (r.p.m)	Air flow	
	850	m ³ /h
l/s		1000
CFM		2119

● **HEATING**

Number of rotations (r.p.m)	Air flow	
	850	m ³ /h
l/s		1000
CFM		2119

■ **MODEL: AO*A36LF**

● **COOLING**

Number of rotations (r.p.m)	Air flow	
	900	m ³ /h
l/s		1056
CFM		2236

● **HEATING**

Number of rotations (r.p.m)	Air flow	
	900	m ³ /h
l/s		1056
CFM		2236

8. OPERATION NOISE

8-1. NOISE LEVEL CURVE

MODEL: AO*A30LB, AO*A30LF

COOLING

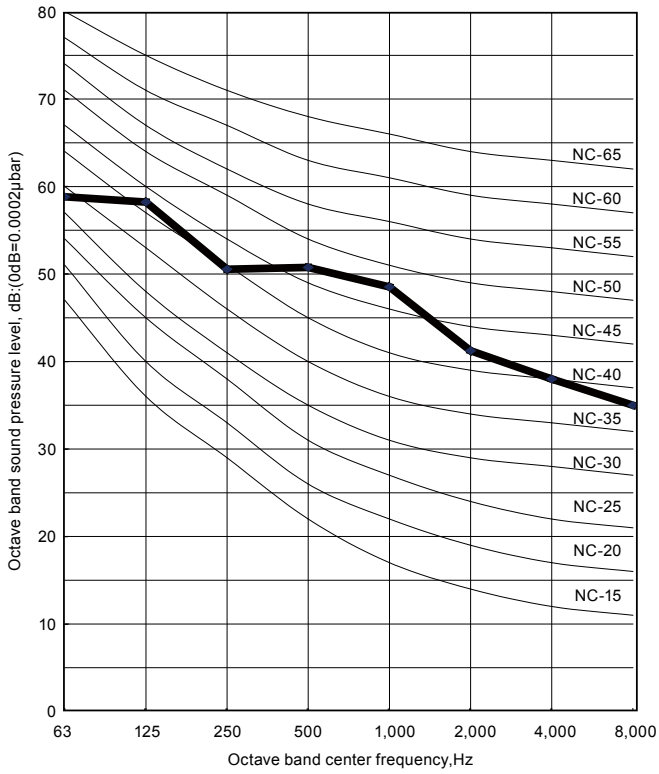

HEATING

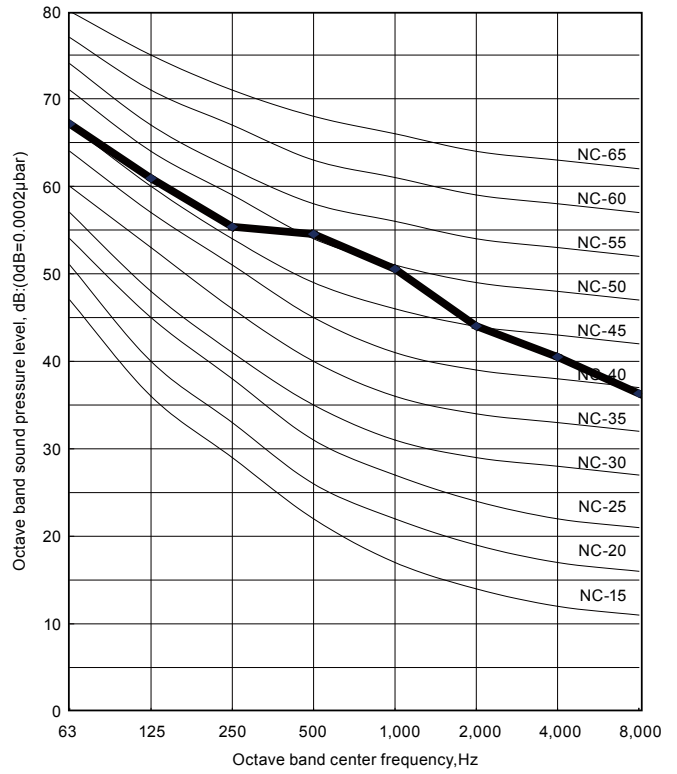

MODEL: AO*A36LB, AO*A36LF

COOLING

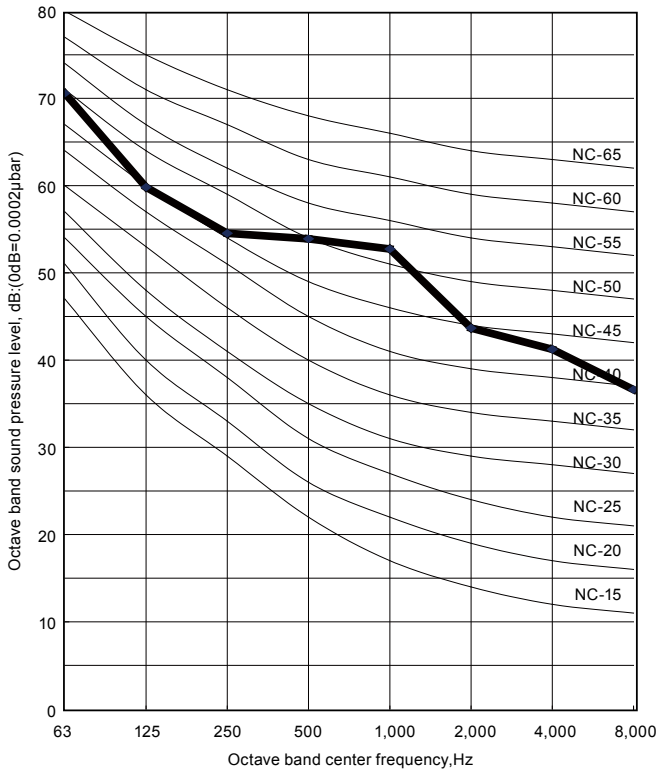

HEATING

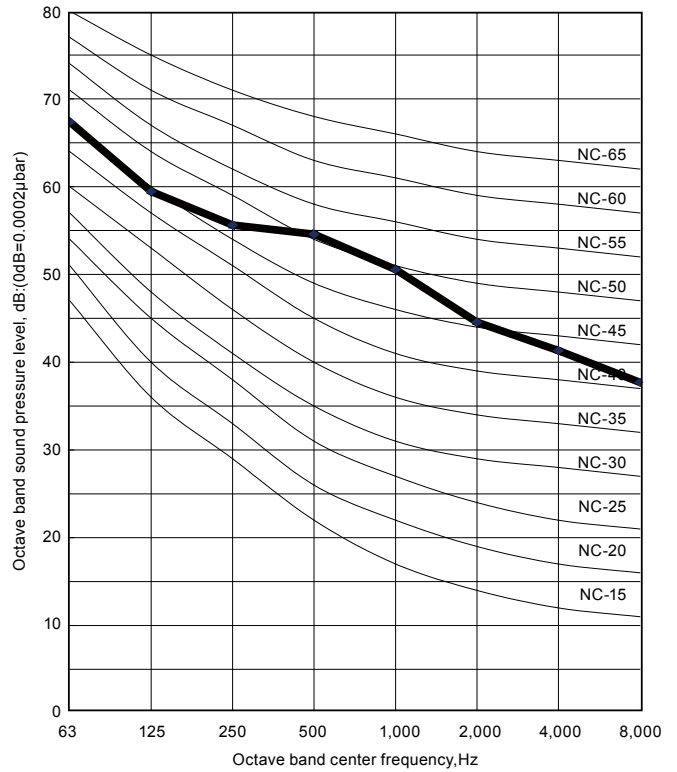

OUTDOOR UNIT
AO*A30-36L

OUTDOOR UNIT
AO*A30-36L

8-2. SOUND LEVEL CHECK POINT

OUTDOOR UNIT
AO#A30-36L

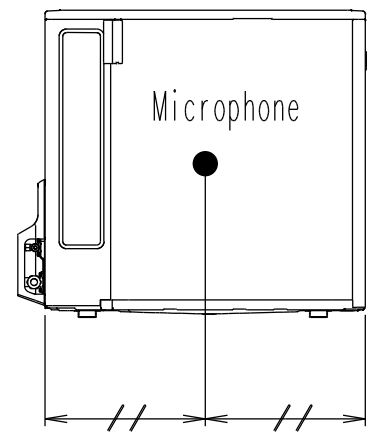
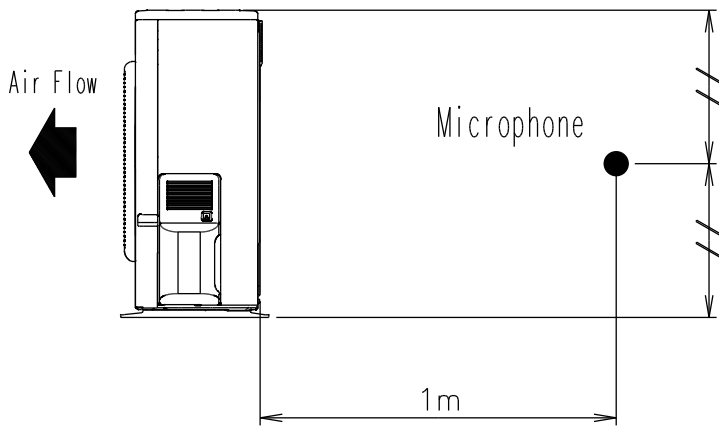

OUTDOOR UNIT
AO#A30-36L

9. ELECTRIC CHARACTERISTICS

Model name			AO*A30LB AO*A30LF	AO*A36LB AO*A36LF
Power supply	Voltage	V	230 ~	
	Frequency	Hz	50	
*1) Max. operating current		A	17.0	20.0
Starting current		A	15.0	
*2) Wiring spec.	Main fuse (Circuit breaker) current	A	30	
	Power cable	mm ²	5.3 - 6.0	
	*3)Limited wiring length	m	21	18

*1) The maximum current is the total current of indoor unit and outdoor unit.

*2) Wiring spec.
Selected sample
(Selected based on Japan Electrotechnical Standard and Codes Committee E0005)

*3) Limited wiring length :
This is the wiring length in case voltage descent is less than 2%.
When the wiring length becomes long, please select the wiring of a more larger diameter.

10. SAFETY DEVICES

	Protection form	Model	
		AO*A30LB AO*A30LF	AO*A36LB AO*A36LF
Circuit protection	Current fuse (NEAR THE TERMINAL)	25A 250V	
	Current fuse (FILTER PRINTED CIRCUIT BOARD)	10A 250V	
	Current fuse (MAIN PRINTED CIRCUIT BOARD)	3.15A 250V	
Fan motor protection	Thermal protection program	OFF : 140±20°C ON : 110±20°C	
High Pressure Protection	Pressure Switch	OFF : 4.2±0.1MPa ON : 3.2±0.15MPa	
Compressor protection	Thermal protection program (COMPRESSOR TEMP.)	OFF : 120°C ON : 80°C	
	Thermal protection program (DISCHARGE TEMP.)	OFF : 110°C ON : After 7 minutes	

OUTDOOR UNIT
AO*A30-36L

OUTDOOR UNIT
AO*A30-36L