

# ERROR DETECTION

## INDOOR UNIT and WIRED REMOTE CONTROL

If you use a wireless remote control, the lamp on the photo detector unit will output error codes by way of blinking patterns.  
If you use a wired type remote control, error codes will appear on the remote control display. See the lamp blinking patterns and error codes in the table. An error display is displayed only during running.

### Remote control

This is possible only on a wired remote control. If an error occurs, the following display will be shown. ("Er" will appear in the set room temperature display.)

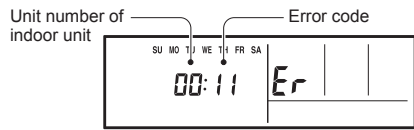

EX. Self-diagnosis

### Indoor unit display (option)

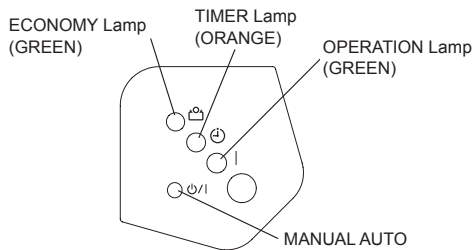

- : 0.5s on / 0.5s off
- ◇ : 0.1s on / 0.1s off
- ( ) : Number of flashing

Indoor unit lamps			Wired remote control	Description
OPERATION (green)	TIMER (orange)	ECONOMY (green)		
●(1)	●(1)	◇	11	Serial communication error
●(1)	●(2)	◇	12	Wired remote control communication error
●(2)	●(3)	◇	23	Combination error
●(3)	●(2)	◇	32	Indoor unit PCB model information error
●(3)	●(5)	◇	35	Manual auto switch error
●(4)	●(1)	◇	41	Inlet air temp. sensor error
●(4)	●(2)	◇	42	Indoor unit Heat Ex. Middle temp. sensor error
●(5)	●(1)	◇	51	Indoor unit fan motor error
●(5)	●(3)	◇	53	Drain pump error
●(6)	●(2)	◇	62	Outdoor unit main PCB model information error or communication error
●(6)	●(3)	◇	63	Inverter error
●(6)	●(4)	◇	64	PFC circuit error
●(6)	●(5)	◇	65	Trip terminal Lerror
●(7)	●(1)	◇	71	Discharge temp. sensor error
●(7)	●(2)	◇	72	Compressor temp. sensor error

Indoor unit lamps			Wired remote control	Description
OPERATION (green)	TIMER (orange)	ECONOMY (green)		
●(7)	●(3)	◇	73	Outdoor unit Heat Ex. liquid temp. sensor error
●(7)	●(4)	◇	74	Outdoor temp. sensor error
●(7)	●(7)	◇	77	Heat sink temp. sensor error
●(8)	●(4)	◇	84	Current sensor error
●(8)	●(6)	◇	86	High pressure switch error
●(9)	●(4)	◇	94	Trip detection
●(9)	●(5)	◇	95	Compressor rotor position detection error (permanent stop)
●(9)	●(7)	◇	97	Outdoor unit fan motor error
●(9)	●(8)	◇	98	Outdoor unit fan motor 2 error
●(9)	●(9)	◇	99	4-way valve error
●(9)	●(10)	◇	9A	Coil (expansion valve) error
●(10)	●(1)	◇	A1	Discharge temp. error
●(10)	●(3)	◇	A3	Compressor temp. error
●(10)	●(5)	◇	A5	Low pressure error

# OUTDOOR UNIT

## TEST RUN

### ⚠ CAUTION

Always turn on the power 6 hours prior to the start of the operation in order to protect the compressor.

### 1. Check items before performing the test run

Make sure to perform the test run.

Before performing the test run, be sure to check the following points.

- (1) Is gas leaking?  
Check connection of each pipe (flare connection part, brazing part).
- (2) Is a breaker installed to the power cable of the outdoor unit ?
- (3) Has each cable been securely connected to the terminal according to the specifications ?
- (4) Are the 3-way valves (gas pipes and liquid pipes) of the outdoor units open?
- (5) Has the power been supplied to the unit for at least 6 hours ?
- (6) Has the necessary local setting been done ?
- (7) Check insulation resistance of 1 MΩ or more using a 500V mega tester.

If no problems are found with the above items, perform the test run according to "Test run method".

If any problems are found, immediately resolve the problem and re-check the items.

### 2. Test run method

### ⚠ CAUTION

If the test run is performed for 1 outdoor unit in a group control system installation, the test run will also be performed for the other units. Therefore, make sure that all of the units have been installed before starting a test run.  
(Group control system installation described in "SPECIAL INSTALLATION METHODS" in the installation manual of the indoor unit.)

Operate [ENTER] (TEST RUN) switch on the display board by the following procedure.

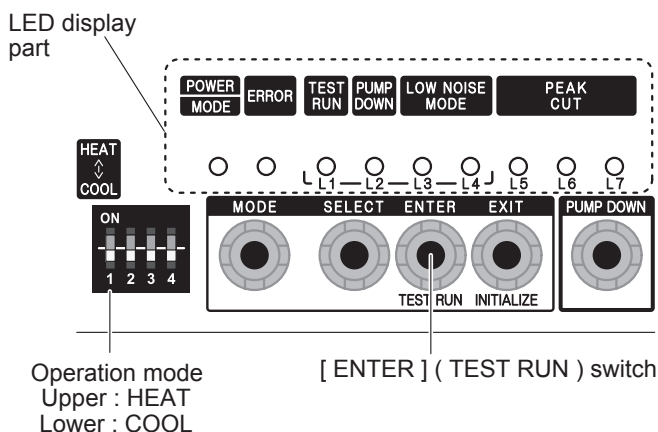

### 2.1. Operating procedures for the test run

- (1) Check the 3-way valves (both at the liquid side and gas side) are opened.
- (2) Set the operation mode to "COOL" or "HEAT".

POWER MODE	ERROR	TEST RUN (L1)	PUMP DOWN (L2)	LOW NOISE (L3) (L4)		PEAK CUT (L5) (L6) (L7)		
●	○	○	○	○	○	○	○	○

In the first test run, be sure to set the operation mode to "COOL".

The operation mode cannot be switched between "COOL" and "HEAT" during the test run. To switch the operation mode between "COOL" and "HEAT", stop the test run, switch the operation mode, and then start the test run again.

- (3) Press [ENTER] (TEST RUN) switch for more than 3 seconds.

POWER MODE	ERROR	TEST RUN (L1)	PUMP DOWN (L2)	LOW NOISE (L3) (L4)		PEAK CUT (L5) (L6) (L7)		
●	○	●	○	○	○	○	○	○

"TEST RUN" LED will light on.

If the compressor is operating at starting the test run, the compressor will stop and, after a while, the test run will start.

Either of the above "LOW NOISE" or "PEAK CUT" will light on during the test run if local setting function is selected.

- (4) Confirm operating status.
- (5) Press [ENTER] (TEST RUN) switch again.

POWER MODE	ERROR	TEST RUN (L1)	PUMP DOWN (L2)	LOW NOISE (L3) (L4)		PEAK CUT (L5) (L6) (L7)		
●	○	○	○	○	○	○	○	○

"TEST RUN" LED lights off, and TEST RUN stops.

Test run will finish after about 60 minutes automatically. At the same time, "TEST RUN" LED will light off.

Test run may be stopped before operating for 60 minutes if an error occurs after a starting test run.

# OUTDOOR UNIT ERROR CODE DISPLAY

Display when an error occurs

POWER MODE	ERROR	TEST RUN (L1)	PUMP DOWN (L2)	LOW NOISE (L3) (L4)		PEAK CUT (L5) (L6) (L7)		
●	Blinks (Hi-speed)	○	○	○	○	○	○	○

Check that the ERROR LED blinks,  
and then short-press the [ENTER] switch once.  
The number of blinks of the LED indicates the type of error.

Display mode ● : ON  
○ : OFF  
◆ : Blink (0.5s ON / 0.5s OFF)  
( ) : Number of flashing

## Error code check table

POWER MODE	ERROR	TEST RUN (L1)	PUMP DOWN (L2)	LOW NOISE (L3) (L4)		PEAK CUT (L5) (L6) (L7)			Description
◆(2)	●	◆(1)	◆(1)	○	○	○	●	●	Serial forward transmission error immediately after operation
◆(2)	●	◆(1)	◆(1)	○	○	●	○	○	Serial forward transmission error during operation
◆(2)	●	◆(2)	◆(2)	○	○	○	○	●	Indoor unit capacity error
◆(2)	●	◆(5)	◆(15)	○	○	○	○	●	Indoor unit error
◆(2)	●	◆(6)	◆(1)	○	○	○	○	●	Over voltage
◆(2)	●	◆(6)	◆(1)	○	○	○	●	●	Power supply frequency error
◆(2)	●	◆(6)	◆(2)	○	○	○	○	●	Outdoor unit PCB model information error
◆(2)	●	◆(6)	◆(2)	○	○	●	●	●	PFC communication error
◆(2)	●	◆(6)	◆(3)	○	○	○	○	●	Inverter error
◆(2)	●	◆(6)	◆(4)	○	○	●	●	●	PFC AD detection error
◆(2)	●	◆(6)	◆(4)	○	●	○	○	○	PFC hardware error
◆(2)	●	◆(6)	◆(5)	○	○	○	●	●	IPM error (Trip terminal L error)
◆(2)	●	◆(6)	◆(8)	○	○	○	●	○	Rush current limiting resistor temp rise protection
◆(2)	●	◆(7)	◆(1)	○	○	○	○	●	Discharge temp. sensor error
◆(2)	●	◆(7)	◆(2)	○	○	○	○	●	Compressor temp. sensor error
◆(2)	●	◆(7)	◆(3)	○	○	○	●	○	Heat Ex. middle temp. sensor error
◆(2)	●	◆(7)	◆(3)	○	○	○	●	●	Outdoor unit Heat Ex. liquid temp. sensor error
◆(2)	●	◆(7)	◆(4)	○	○	○	○	●	Outdoor temp. sensor error
◆(2)	●	◆(7)	◆(7)	○	○	○	○	●	Heat sink temp. sensor error
◆(2)	●	◆(7)	◆(7)	○	○	○	●	○	PFC heat sink temp. sensor error
◆(2)	●	◆(8)	◆(4)	○	○	○	○	●	Current sensor 1 error (stoppage permanently)
◆(2)	●	◆(8)	◆(6)	○	○	●	○	○	High pressure switch 1 error
◆(2)	●	◆(8)	◆(6)	○	○	●	●	○	Pressure sensor error
◆(2)	●	◆(9)	◆(4)	○	○	○	○	●	Trip detection (stoppage permanently)
◆(2)	●	◆(9)	◆(5)	○	○	○	○	●	Compressor motor control error (stoppage permanently)
◆(2)	●	◆(9)	◆(5)	○	○	●	○	●	Compressor motor loss of synchronization (stoppage permanently)
◆(2)	●	◆(9)	◆(7)	○	○	○	●	●	Outdoor unit fan motor 1 error (Duty error)
◆(2)	●	◆(9)	◆(8)	○	○	○	●	●	Outdoor unit fan motor 2 error (Duty error)
◆(2)	●	◆(9)	◆(9)	○	○	○	○	●	4-way valve error
◆(2)	●	◆(10)	◆(1)	○	○	○	○	●	Discharge temp. 1 error (stoppage permanently)
◆(2)	●	◆(10)	◆(3)	○	○	○	○	●	Compressor 1 temp. error (stoppage permanently)
◆(2)	●	◆(10)	◆(5)	○	○	○	○	●	Low pressure error

# OUTDOOR UNIT

## PUMP DOWN (Refrigerant collecting operation)

Perform the following procedures to collect the refrigerant when moving the indoor unit or outdoor unit

**WARNING**  
Never touch electrical components such as the terminal blocks or reactor except the switch on the display board. It may cause a serious accident such as electric shock.

**CAUTION**  
Perform the pump down operation before disconnecting any refrigerant pipe or electric cable.

Collect refrigerant from the service port or the 3-way valve if pump down cannot be performed.

In case of a group control system installation, do not turn the power off pump down is completed in all outdoor units.  
(Group control system installation described in "SPECIAL INSTALLATION METHODS" in the installation manual of the indoor unit.)

Operate [PUMP DOWN] switch on the display board in the manner described below.

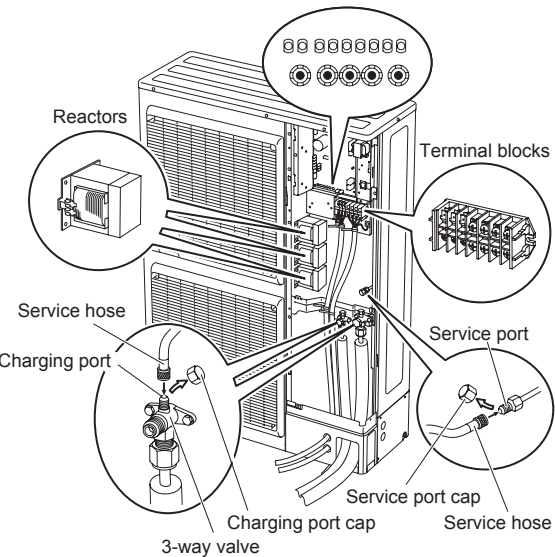
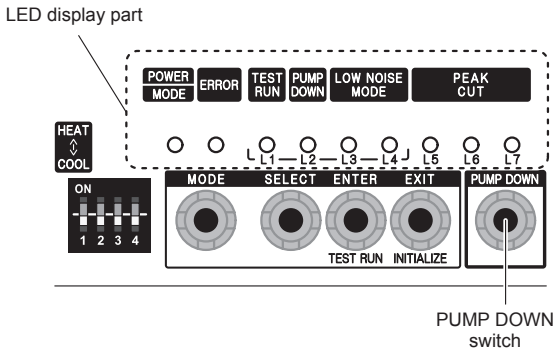

### 1. Preparation for pump down

Confirm that the power is off, and then open the service panel.

### 2. Pump down procedure

- (1) Check the 3-way valves (both at the liquid side and gas side) are opened.
- (2) Turn the power on.

POWER	ERROR	TEST RUN (L1)	PUMP DOWN (L2)	LOW NOISE (L3)	(L4)	PEAK CUT (L5) (L6) (L7)		
●	○	○	○	○	○	○	○	○

- (3) Press [PUMP DOWN] switch for 3 seconds or more after 3 minutes after power on.

POWER	ERROR	TEST RUN (L1)	PUMP DOWN (L2)	LOW NOISE (L3)	(L4)	PEAK CUT (L5) (L6) (L7)		
●	○	○	●	○	○	●	●	●

LED display lights on as shown in the above figure, and the fans and the compressor start operating.

If the [PUMP DOWN] switch is pressed while the compressor is operating, the compressor will stop, then start again in about 3 minutes.

- (4) LED display will change as shown below about 3 minutes after the compressor starts. Fully close the 3-way valve on the liquid pipe side at this stage.

POWER	ERROR	TEST RUN (L1)	PUMP DOWN (L2)	LOW NOISE (L3)	(L4)	PEAK CUT (L5) (L6) (L7)		
●	○	○	●	○	○	○	●	●

If the valve on the liquid pipe side is not closed, the pump down cannot be performed.

- (5) When LED display changes as shown in the below figure, close the 3-way valve on the gas pipe side tightly.

POWER	ERROR	TEST RUN (L1)	PUMP DOWN (L2)	LOW NOISE (L3)	(L4)	PEAK CUT (L5) (L6) (L7)		
●	○	○	●	○	○	○	○	●

If the valve on the gas pipe side is not closed, refrigerant may flow into the piping after the compressor stops

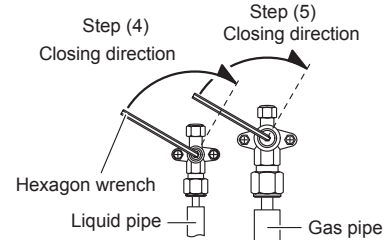

- (6) LED display changes after 1 minute as shown in the figure below

POWER	ERROR	TEST RUN (L1)	PUMP DOWN (L2)	LOW NOISE (L3)	(L4)	PEAK CUT (L5) (L6) (L7)		
●	○	○	●	○	○	○	○	○

Fans and compressor stop automatically.

If the pump down is successfully completed (the above LED display is shown), the outdoor unit remains stopped until the power is turned off.

- (7) Turn the power off.

POWER	ERROR	TEST RUN (L1)	PUMP DOWN (L2)	LOW NOISE (L3)	(L4)	PEAK CUT (L5) (L6) (L7)		
○	○	○	○	○	○	○	○	○

PUMP DOWN is completed.

(Note)

To stop pump down, press the [PUMP DOWN] switch again.

To start the pump down again after the compressor is automatically stopped due to an error, turn the power off and open the 3-way valves. Wait 3 minutes, turn the power on and start the pump down again.

When starting the operation after completion of the pump down, turn the power off, and then open the 3-way valves. Wait 3 minutes, turn the power on and perform a test run in the "COOL" operation mode.