



Accessories for Easyzone System

AZEZ6DAIST/L

To increase the flexibility and speed of installation of the Easyzone multi-room air conditioning system, Daikin are glad to announce the release of a series of new accessories.

Zone room) controllers

Previously only available in a wireless, battery powered option, the Think touch screen and Lite simplified controllers are now available in a hardwired option. This alleviates the issue of having to change the battery within the controller.

Model	Description	Trade Price
AZCE6THINKCB	Additional wired touch screen room thermostat	£160.00
AZCE6LITECB	Additional wired simplified room thermostat	£110.00



Think remote controller



Lite remote controller

Zone controlling cabling

Previously only available as a 10 metre length, the 2x0.22+2x0.5 cable required for the zone controllers is now also available in a 100 metre length.



Model	Description	Trade Price
AZX6CABLEBUS100	100m of interconnecting cable for Easyzone thermostats	£92.00

Webserver cloud control

Adding the ability to remotely control up to 32 Easyzone fan coil units via a smart phone App or dedicated web site interface, the Webserver cloud control interfaces permits remote monitoring and control of your Easyzone zones. Available in 2 versions, one wired for ethernet connection to the site network, and the other is wireless for pairing with the sites Wi-Fi. N.B. These interfaces cannot be combined with the BACNet interface.



Wired Interface



Wireless Interface

Model	Description	Trade Price
AZX6WSCLOUDDINC	Webserver cloud (wired)	£205.00
AZX6WSCLOUDDINR	Webserver cloud (wireless)	£205.00

BACNet gateway

To permit remote control of each zone via a BMS system or Daikin Intelligent Touch Manager*, a BACNet gateway ethernet adapter has been released. A single gateway will permit control of a single Easyzone unit – of up to 8 zones.

Model	Description	Trade Price
AZX6BACNET	BACNET gateway	£205.00

* In addition to a AZX6BACNET per Easyzone unit, a DCM009A51 BACNet Client software is required per Intelligent Touch Manager.

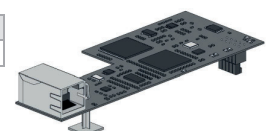

ACCESSORIES FOR EASYZONE SYSTEM

Supply air diffusers & plenum

To simplify selection of a suitable supply air diffuser, Daikin now offer a Wall mounted and a Ceiling mounted diffuser, along with a suitable plenum.

Both types of diffuser are 140mm wide by 150mm deep.

The wall mounted diffuser is of the double deflection type – both horizontal & vertical moveable vanes, whilst the ceiling mounted diffuser has horizontal vanes fixed at 15° and moveable vertical slates.

The plenum is provided with a Ø200mm spigot that can be adapted from front to top connection.

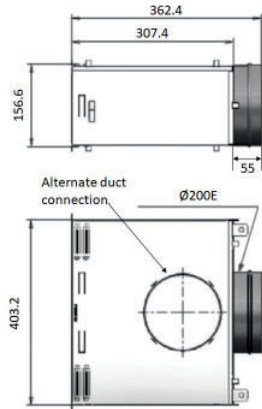

Plenum

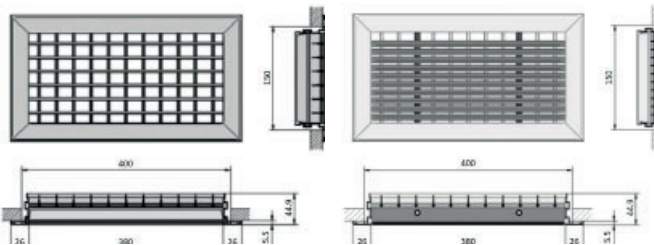

Wall mounted diffuser

Ceiling mounted diffuser

Model	Description	Trade Price
RDHV040015BKX	Air diffuser - wall	£26.00
RLQV040015BKX	Air diffuser - ceiling	£39.00
PREJ040015T	Plenum for wall & ceiling diffuser	£84.00

Air intake plenums

Designed to perfectly match the return air connection on the Daikin indoor unit, a range of air intake plenums is now available.

Each plenum is provided with a number of Ø250Emm* spigots to ensure adequate airflow is available for correct unit operation.

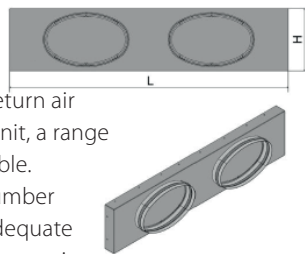

Model	Description	Trade Price
AZCEZDAPR07XS	Standard unit return plenum – XS	£92.00
AZCEZDAPR07S	Standard unit return plenum – S	£92.00
AZCEZDAPR07M	Standard unit return plenum – M	£105.00
AZCEZDAPR07L	Standard unit return plenum – L	£134.00
AZCEZDAPR07XL	Standard unit return plenum - XL	£150.00

Model	Compatible FCU	Length (mm)	Height (mm)	Depth (mm)	No. of Spigots
AZCEZDAPR07XS	FXSQ15A, FXSQ20A, FXSQ25A, FXSQ32A	507.6	213.6	96	1
AZCEZDAPR07S	FBA35A, FBA50A, FXSQ40A, FXSQ50A	657.6	213.6	96	1
AZCEZDAPR07M	FBA60A, FBA71A, FXSQ63A, FXSQ80A	957.6	213.6	96	2
AZCEZDAPR07L	FBA100A, FBA125A, FBA140A, FXSQ100A, FXSQ125A	1357.6	213.6	96	4
AZCEZDAPR07XL	FXSQ140A	1507.6	213.6	96	4

* The Ø250Emm connections are elliptical in shape but are equivalent to a Ø250mm circular connection.

The present leaflet is drawn up by way of information only and does not constitute an offer binding upon Daikin UK. Daikin UK has compiled the content of this leaflet to the best of its knowledge. No express or implied warranty is given for the completeness, accuracy, reliability or fitness for particular purpose of its content and the products and services presented therein. Specifications are subject to change without prior notice. Daikin UK explicitly rejects any liability for any direct or indirect damage, in the broadest sense, arising from or related to the use and/or interpretation of this leaflet. All content is copyrighted by Daikin UK.

Return air diffuser c/w filter & plenum

To complement the supply air diffusers, a 500mm wide x 500mm deep return air diffuser is available.

The diffuser is supplied with a removable filter membrane and has moveable horizontal slates.

The plenum is designed to offer maximum installation flexibility with the choice of 5 difference Ø250Emm* and 2 Ø150mm duct connections.

Model	Description	Trade Price
RRFR050050BTX	Air intake filter slot + filter	£140.00
BR500	Air intake plenum for RRFR050050BTX	£189.00

* The Ø250Emm connections are elliptical in shape but are equivalent to a Ø250mm circular connection.

Refer to the below table to establish how many return air diffusers are required to meet the return air demand of the associated fan coil unit.

Fan coil unit	No. of diffusers Rqd.
FBA35A, FBA50A, FXSQ15A, FXSQ20A, FXSQ25A, FXSQ32A, FXSQ40A, FXSQ50A	1
FBA60A, FBA71A, FXSQ63A, FXSQ80A	2
FBA100A, FBA125A, FBA140A, FXSQ100A, FXSQ125A, FXSQ140A	4

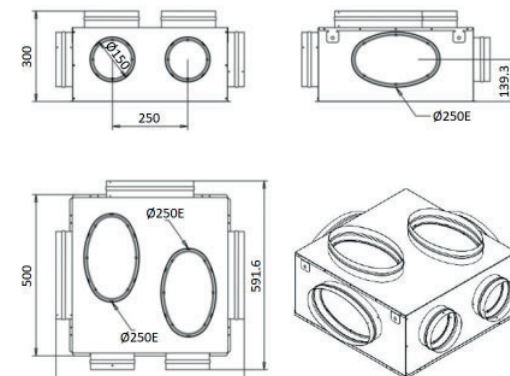

Plenum

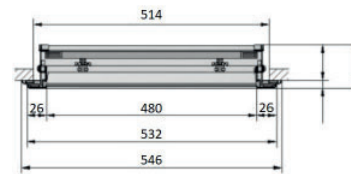
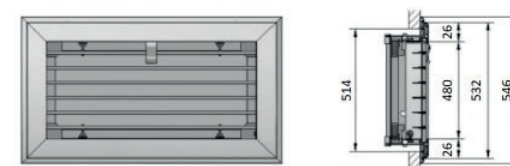

Return air diffuser

Availability

All accessories are now available ex-stock

