

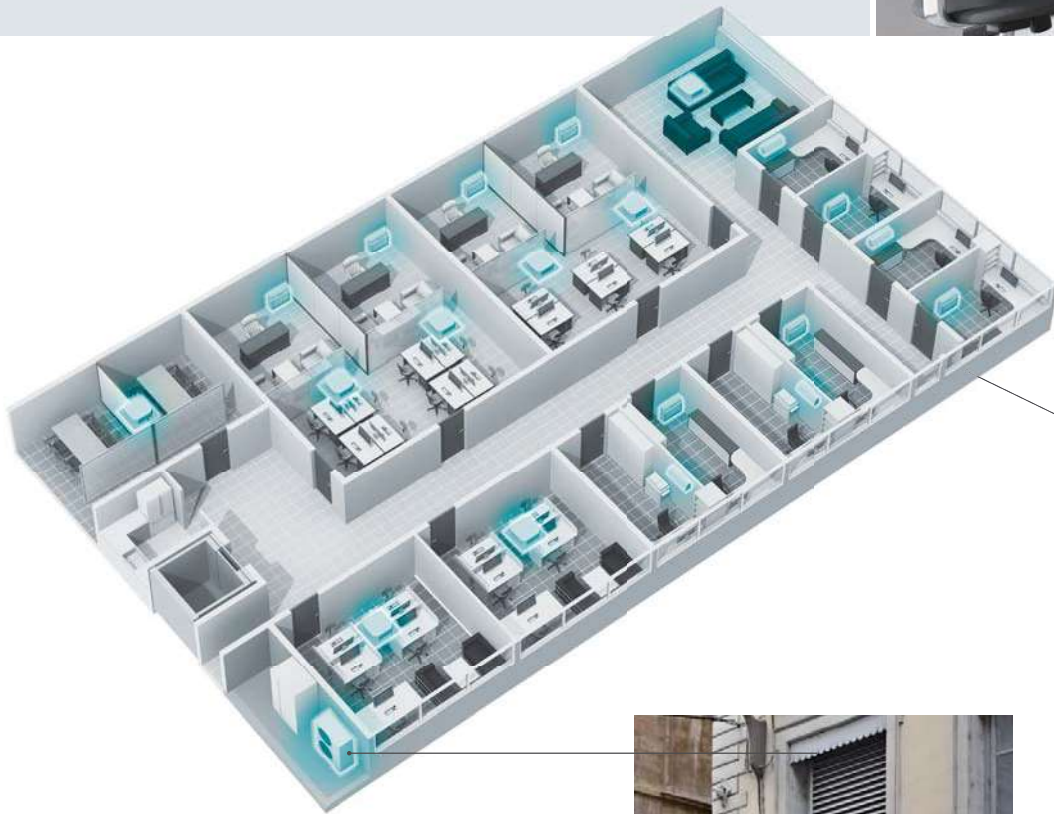

Small Offices

For Light Commercial

Fujitsu General provides perfect ideal air conditioning systems that take into account energy saving, low noise, comfortable airflow, small room application and centralised control for small-sized office buildings with many small rooms.



J-IV

J-IVL

J-IVL
High capacity model

NEW

AIRSTAGE™ J Series Up to 18 HP with a compact outdoor unit

This small VRF system is suitable for a building with many small rooms. Max. 42* indoor units can be connected.

*Only J-IVL 18 HP model

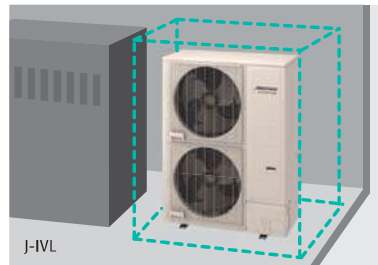

Compact and low noise outdoor unit

This compact outdoor unit does not take up much space even if installed in a machine room or on the rooftop. This unit provides enough static pressure even if there are louvers. Low noise operation is possible at nighttime by a low noise mode.

High Efficiency

Efficiency is improved significantly by using DC twin rotary compressor, inverter technology, and large heat exchanger



DC twin rotary compressor

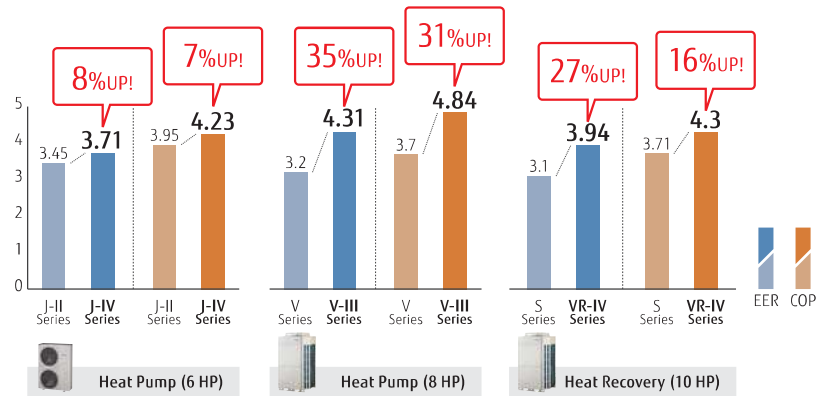

ALL DC High efficiency design with top class SEER/SCOP

All VRF Series including J-IVL Series have DC technology to realise the high efficiency operation. This enhances the durability and reliability of VRF Series.

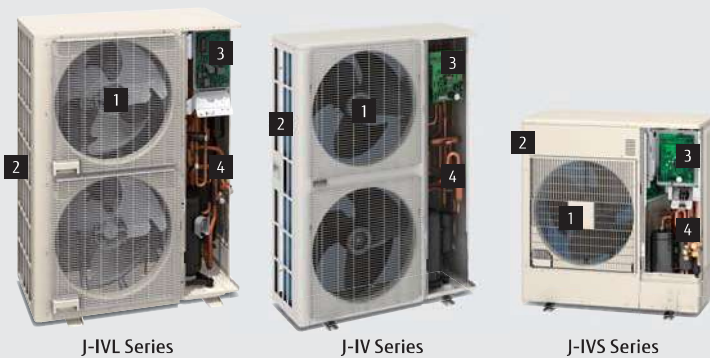

J-IVL Series

J-IV Series

J-IVS Series

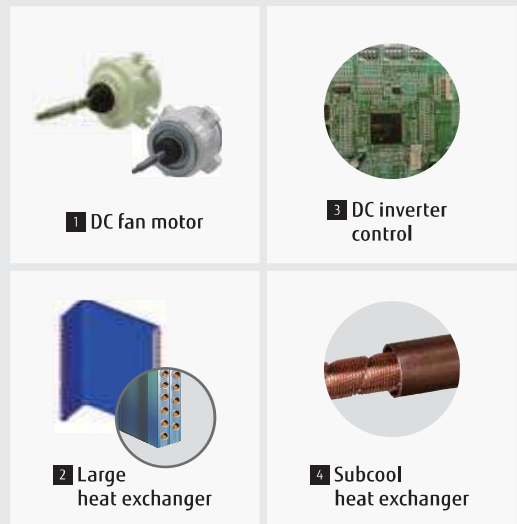

V Series

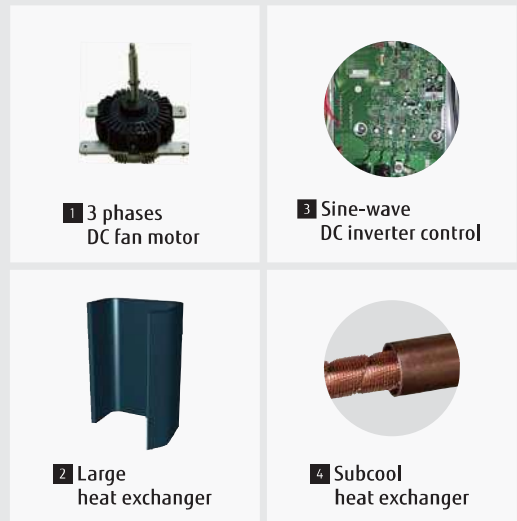

Design Flexibility



Top class Compact design



Compact outdoor units are at the top of the class in the industry with an optimal compact design. (Up to 18 HP)



Long piping design



Piping design suitable for long, narrow office buildings with a large elevation difference are also possible. (AIRSTAGE™ J-IVL Series)

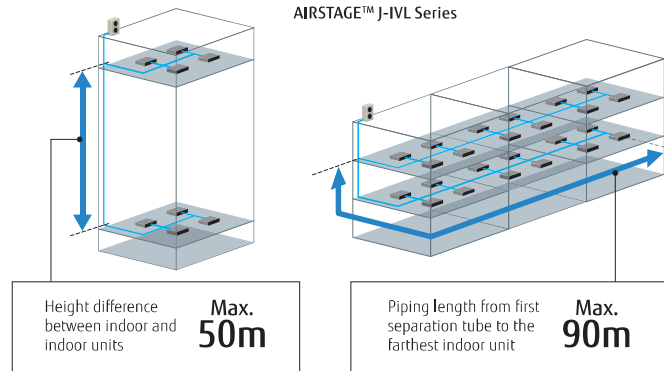

Overall piping length Max. 1,000 m



World's top class overall piping length of 1,000 m allows for application in a wide variety of buildings.

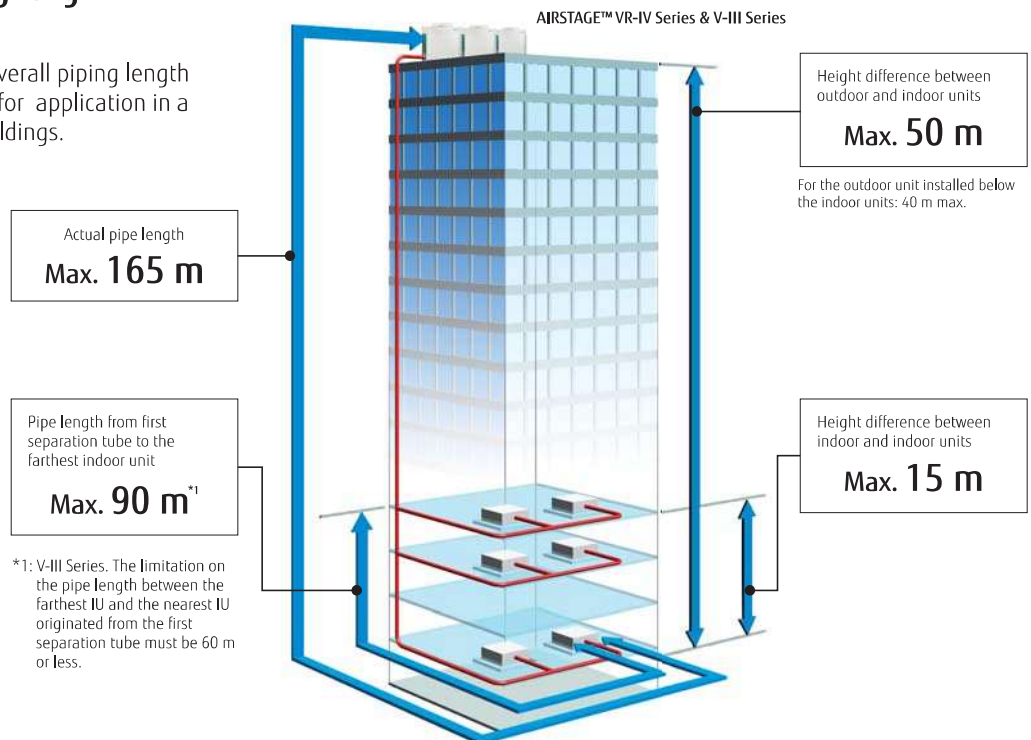

High capacity connection

Series		Connectable indoor unit capacity range	Connectable indoor unit number
	AIRSTAGE™ J-I-VL Series 14/16/18 HP Heat Pump type	50% to 150%*2	up to 42*4
	AIRSTAGE™ J-I-VL Series 8/10/12 HP Heat Pump type	50% to 150%*2	up to 30*5
	AIRSTAGE™ J-I-V Series Heat Pump type	50% to 150%*2	up to 14*6
	AIRSTAGE™ J-I-VS Series Heat Pump type	50% to 130%*2	up to 13
	AIRSTAGE™ VR-IV Series Heat Recovery Modular type	25%*7 to 150%*2	up to 64
	AIRSTAGE™ V-III Series Heat Pump Modular type	50% to 150%*3	up to 64

*2: Conditions of maximum connectable indoor unit capacity ratio is as the chart.

*3: Max. capacities in the combinations including the 18 HP outdoor unit fall below 150%.

*4: J-I-VL Series 18 HP model only.

*5: J-I-VL Series 12 HP model only.

*6: J-I-V Series 6 HP model only.

*7: For modular type, 25% to 49.9% operation in the entire system is available. (by one unit operation)



Designed for low refrigerant charge

Optimal design of indoor unit and outdoor unit reduces the refrigerant volume and special detection is not required even when installing in a small room of about 15 m².



Various optional parts

- Intake fresh air with our Fresh Air Intake kit
- Comfortable temperature control with a remote sensor
- Operation by linking up to ventilation equipment and air handling unit with the DX-Kit



Fresh Air Intake kit



EEV unit



Control unit



Low ambient operation

Refrigeration cycle technology allows cooling operation even at -15°C.



Wide operating range

Installation in extreme temperature conditions is possible due to an increase in operational range.

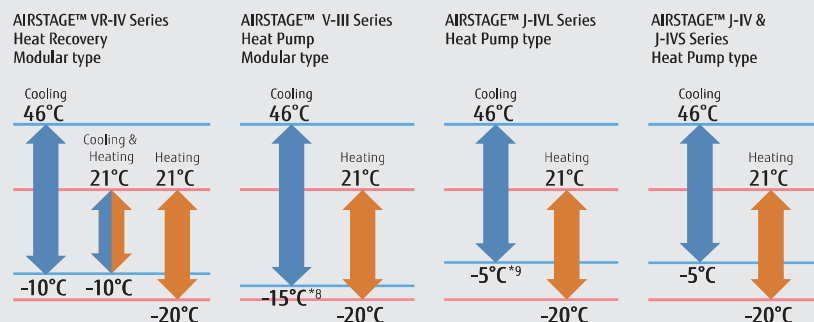

*8: Note: When a multiple outdoor unit connection is used, operating range is from -5°C to 46°C in cooling.

*9: Only when all indoor units are 5.6 kW or more in the system, the operation range is -15°C to 46°C.

Easy Installation

Easily transported

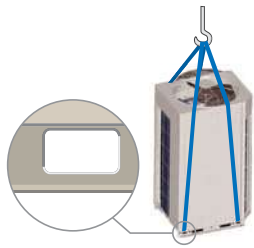

Easily craned using lifting belt hooks
Design of outdoor unit allows for lifting straps to be used

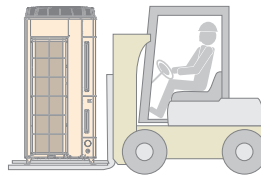

Transporting by forklift
Transport with forklift is possible.



Can be transported in a small elevator

Easy access

By adopting a L-Shape front panel that can be removed, the workspace for installation and service has been significantly expanded by this new design. For multiple installations, work is performed easily and efficiently even in a narrow space.

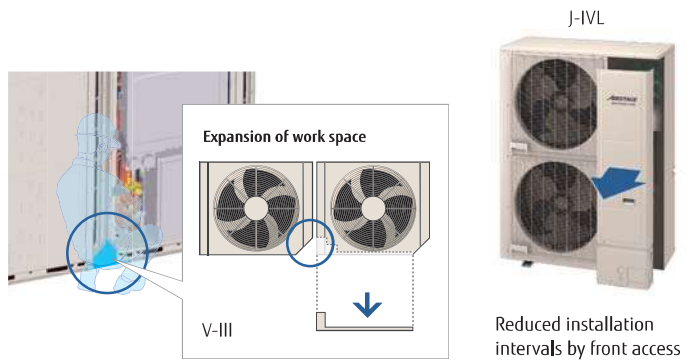

Reduced installation intervals by front access

Flexible piping connection

Piping and wiring are available to the front, left and right, and bottom.





Simple wiring work

Installation of the wiring systems is made easier as the communication wiring can be installed in parallel or in series between the indoor, outdoor and RB units.

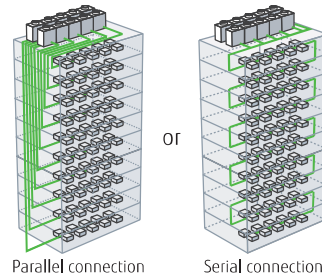

Up to maximum length
3,600 m

Note: Serial connection can't use the automatic address setting in a multiple refrigerant system.

Easy evacuation - using vacuum mode function

The vacuum mode function enables all expansion valves of indoor units to be fully opened, making it easy to evacuate all the air inside pipe lines and indoor units.

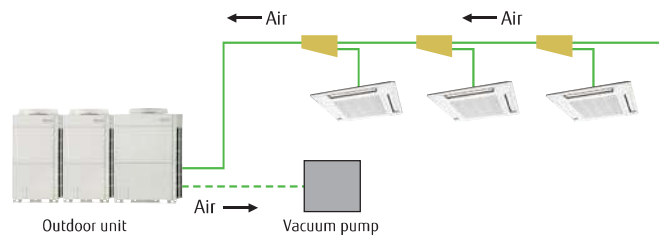

Automatic address setting

The address of the indoor unit, RB unit and signal amplifier through the automatic function setting on the outdoor unit PCB.

Automatic address setting is performed at outdoor unit

Addresses are automatically distributed from outdoor unit.

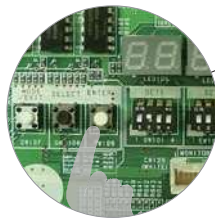

Press the push button of outdoor unit.

Manual address setting from indoor unit and remote controller is also possible.

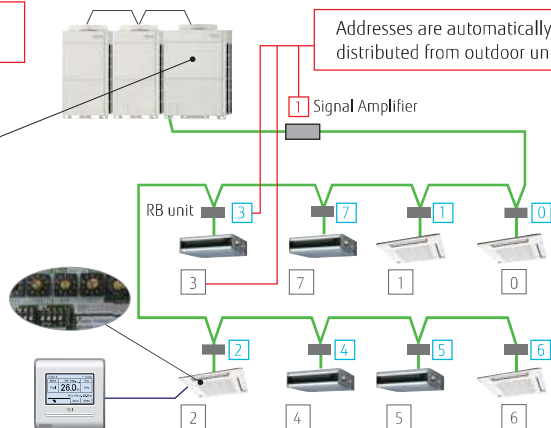

Easy commissioning by Service Tool

Service tools can be used to check the refrigerant temperature, pressure, and the operating status of the electronic expansion valve, making it easy to determine whether the units are connected properly.

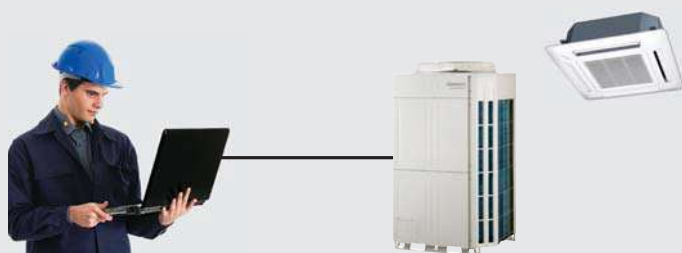

Easy Service & Maintenance

Design for Easy Maintenance

7 segment LED is used to make it easy to check the details about the function setting status, refrigerant temperature, pressure, compressor operation time, and other factors for each model to make it easy to perform self-diagnostics.

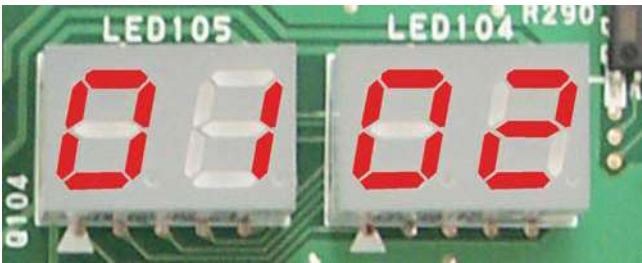

Easy to read 7-segment LED :

Confirm detailed operational and error status without using any specific equipment.

Error status can be checked easily by outdoor unit display

- Operation mode status
- Discharge temperature/Pressure status
- Compressor operation indication
- Address/type/number of outdoor unit

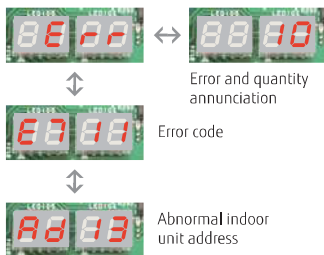

- Error status can be checked easily by outdoor unit display

Movable PCB panel

Easier for maintenance work behind the PCB

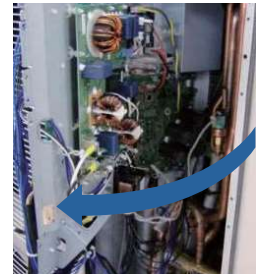

Heat Pump

for Small Capacity Type

AIRSTAGE™ J-IVS

It Can be Easily Positioned and Installed

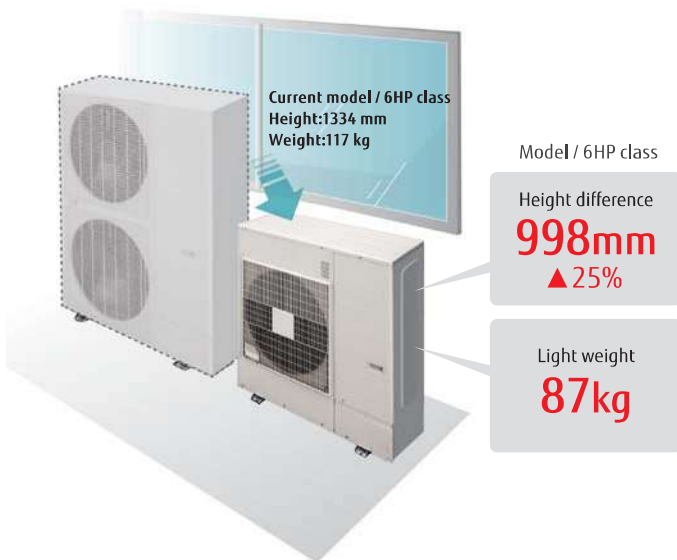

Small and light weight outdoor unit

This model is much more compact than conventional 6HP comparable outdoor units. Even when installed on the balcony it fits within the height of the fence. The compact size with a height of less than 1 m allows it to be installed under windows and in tight spaces

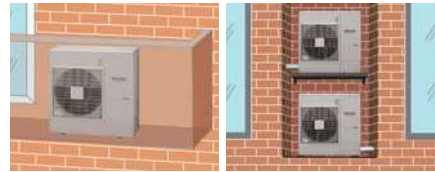

Low sound level design

Significantly low sound level is realised by using DC twin rotary compressor, inverter technology, and advanced airflow structure design.

Long piping length

Our advanced refrigerant control technology allows us to achieve a total refrigerant piping length of 80 m. This opens up possibilities in system design.

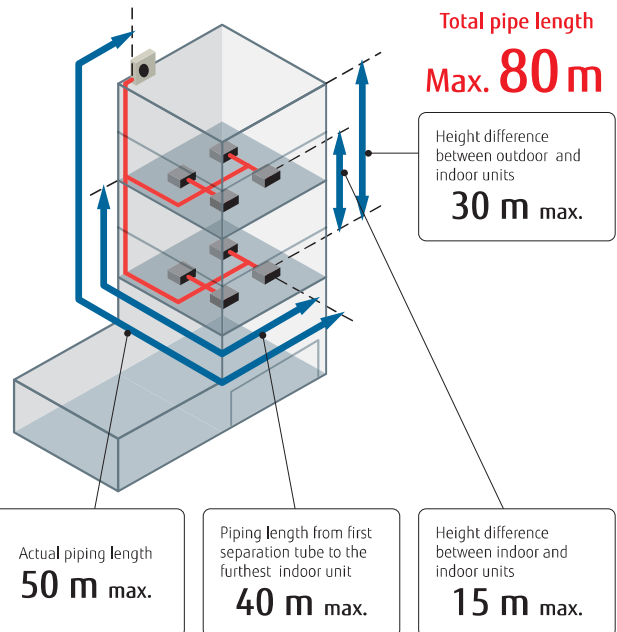

Up to 13 units* can be connected

Improvements in the design of the outdoor heat exchanger combined with our new 1.1kW indoor units mean that up to 13 indoor units can be connected.

*: 6 HP model

Model	Current model (J-IIS)			New model (J-IVS)		
	4	5	6	4	5	6
Rating Capacity range (HP)	4	5	6	4	5	6
Max. Connectable indoor unit	1-7	1-8	1-8	1-11	1-12	1-13



NEW

Specifications

Rating Capacity range		HP	4	5	6
Model name			AJY040LCLBH	AJY045LCLBH	AJY054LCLBH
Maximum Connectable Indoor Unit			1-11	1-12	1-13
Power source			Single phase, ~230V, 50Hz		
Capacity	Cooling	kW	12.1	14.0	15.1
	Nominal Heating		12.1	14.0	15.1
	Max Heating		13.6	16.0	16.5
Input power	Cooling	kW	3.44	4.43	5.03
	Nominal Heating		2.55	3.11	3.52
	Max Heating		3.27	3.93	4.11
EER	Cooling		3.52	3.16	3.00
COP	Nominal Heating		4.74	4.51	4.30
	Max Heating		4.16	4.07	4.01
Airflow rate		m ³ /h	4,040	4,200	4,200
Sound pressure level / Power level	Cooling	dB(A)	51 / 67	53 / 69	54 / 70
	Heating		54 / 68	56 / 69	56 / 70
Heat exchanger fin			Blue fin	Blue fin	Blue fin
Net Dimensions	Height	mm	998	998	998
	Width		970	970	970
	Depth		370	370	370
Weight		kg	86	86	87
Refrigerant	Type (Global Warming Potential)		R410A (2,088)	R410A (2,088)	R410A (2,088)
	Charge	kg(CO2eq-T)	4.0 (8.4)	4.0 (8.4)	4.0 (8.4)
Connection pipe diameter	Liquid	mm	9.52	9.52	9.52
	Gas		15.88	15.88	15.88
Total pipe length		m	80	80	80
Max. height difference		m	30	30	30
Operation range	Cooling	°C	-5 to 46	-5 to 46	-5 to 46
	Heating		-20 to 21	-20 to 21	-20 to 21

Note : Specifications are based on the following conditions.

Cooling : Indoor temperature of 27°CDB / 19°CWB, and outdoor temperature of 35°CDB / 24°CWB.
 Heating : Indoor temperature of 20°CDB / (15°CWB), and outdoor temperature of 7°CDB / 6°CWB.
 Pipe length : 7.5 m; Height difference between outdoor unit and indoor unit : 0 m.
 The protective function may work when using it outside the operation range.

Dimensions

(Unit : mm)

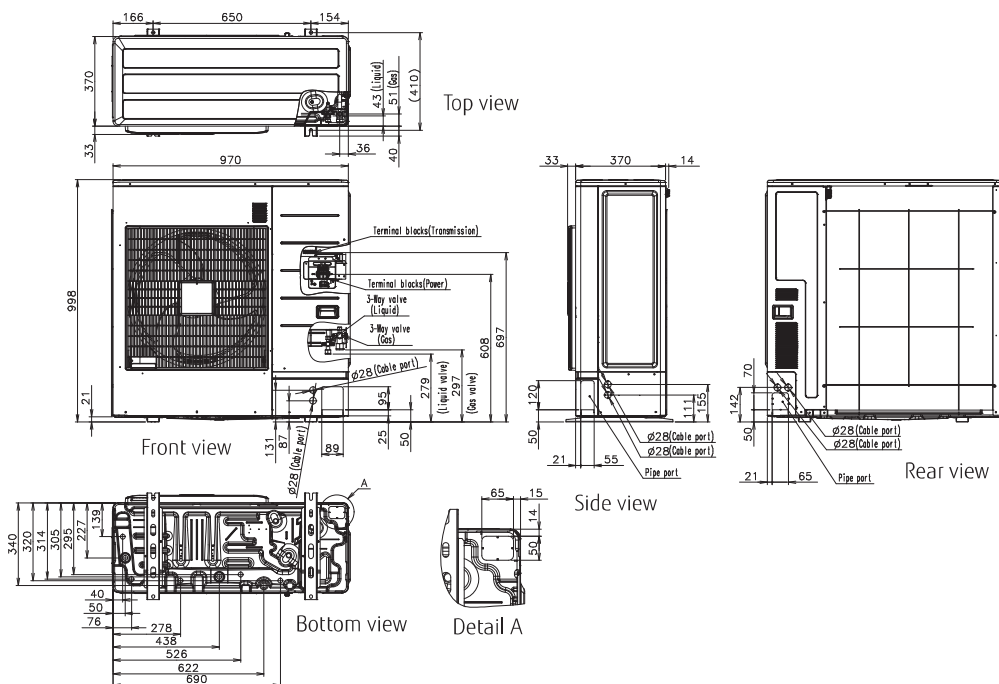

Heat Pump for Small Capacity Type

AIRSTAGE™ J-III



Long Piping Length

Our advanced refrigerant control technology allows us to achieve a total refrigerant piping length of 180 m. This opens up new possibilities in system design.



Total pipe length
Max. 180 m

Height difference
between outdoor and
indoor units
50 m max.

For the outdoor unit
installed below the
indoor units: 40 m max.

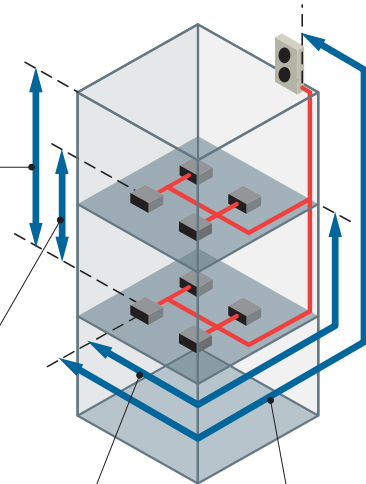

Height difference
between indoor and
indoor units
15 m max.

Piping length from first
separation tube to the
furthest indoor unit
40 m max.

Actual piping length
120 m max.

Non-stop oil recovery operation

A comfortable room condition is maintained during oil recovery mode because the product continues to operate without stopping the cooling or heating operation.

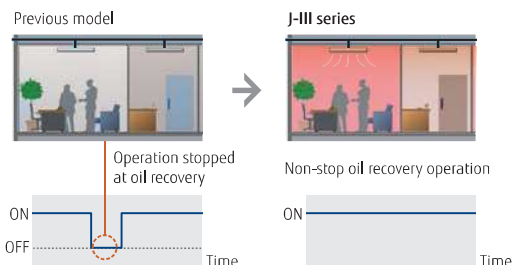

Easier Installation

Connection check function : Possible to confirm whether wiring connection and address setting are correct by a quick check run function.

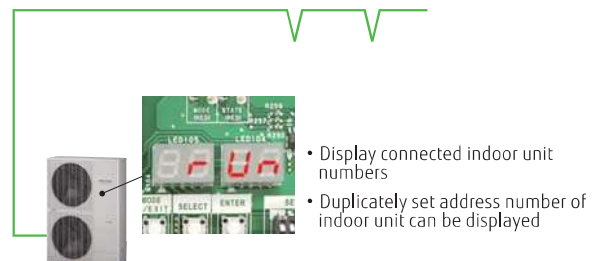

4,5,6HP : AJY040LBLAH / AJY045LBLAH / AJY054LBLAH
 AJY040LELAH [3phase] / AJY045LELAH [3phase] / AJY054LELAH [3phase]



Specifications

Rating Capacity range		HP	4	5	6
Model name			AJY040LBLAH	AJY045LBLAH	AJY054LBLAH
Maximum Connectable Indoor Unit			1-9	1-10	1-13
Power source			Single-phase, ~230V, 50Hz		
Capacity	Cooling	kW	12.1	14.0	15.5
	Heating		13.6	16.0	18.0
Input power	Cooling	kW	2.90	3.57	4.18
	Heating		2.80	3.55	4.26
EER/SEER (LOT21)	Cooling	W/W	4.17 / 5.99	3.92 / 5.85	3.71 / 5.78
COP/SCOP (LOT21)	Heating	W/W	4.86 / 3.92	4.51 / 3.85	4.23 / 3.78
Airflow rate		m ³ /h	6,200	6,400	6,900
Sound pressure level / Power level	Cooling	dB(A)	50 / 66	51 / 67	53 / 69
	Heating		52 / 68	53 / 69	55 / 71
Minimum Recommended MCB		AMP	32	32	32
Net Dimensions	Height	mm	1,334	1,334	1,334
	Width		970	970	970
	Depth		370	370	370
Weight		kg	117	117	119
Refrigerant	Type		R410A	R410A	R410A
	Charge	kg	4.8	5.3	5.3
Connection pipe diameter	Liquid	Inch	3/8	3/8	3/8
	Gas		5/8	5/8	3/4
Total pipe length		m	180	180	180
Max. height difference			50/40 (Outdoor unit: Upper/Lower)		
Operation range	Cooling	°C	-5 to 46	-5 to 46	-5 to 46
	Heating		-20 to 21	-20 to 21	-20 to 21

		4	5	6
Model name		AJY040LELAH	AJY045LELAH	AJY054LELAH
Maximum Connectable Indoor Unit		1-9	1-10	1-13
Power source		3-phase, ~400V, 50Hz		
Capacity	Cooling	12.1	14.0	15.5
	Heating	13.6	16.0	18.0
Input power	Cooling	2.79	3.46	3.99
	Heating	2.71	3.40	4.08
EER/SEER (LOT21)	Cooling	4.33 / 6.15	4.05 / 5.98	3.88 / 5.97
COP/SCOP (LOT21)	Heating	5.01 / 4.10	4.70 / 4.04	4.41 / 4.00
Airflow rate		6,200	6,400	6,900
Sound pressure level / Power level	Cooling	50 / 66	51 / 67	53 / 69
	Heating	52 / 68	53 / 69	55 / 71
Minimum Recommended MCB		16	16	16
Net Dimensions	Height	1,334	1,334	1,334
	Width	970	970	970
	Depth	370	370	370
Weight		119	119	119
Refrigerant	Type	R410A	R410A	R410A
	Charge	kg	4.8	5.3
Connection pipe diameter	Liquid	3/8	3/8	3/8
	Gas	5/8	5/8	3/4
Total pipe length		180	180	180
Max. height difference		50/40 (Outdoor unit: Upper/Lower)		
Operation range	Cooling	-5 to 46	-5 to 46	-5 to 46
	Heating	-20 to 21	-20 to 21	-20 to 21

Note: Specifications are based on the following conditions.

Cooling: Indoor temperature of 27°CDB/19°CWB, and outdoor temperature of 35°CDB/24°CWB.

Heating: Indoor temperature of 20°CDB/(15°CWB), and outdoor temperature of 7°CDB/6°CWB.

Pipe length: 7.5 m; Height difference between outdoor unit and indoor unit: 0 m.

The protective function may work when using it outside the operation range.

Dimensions

(Unit : mm)

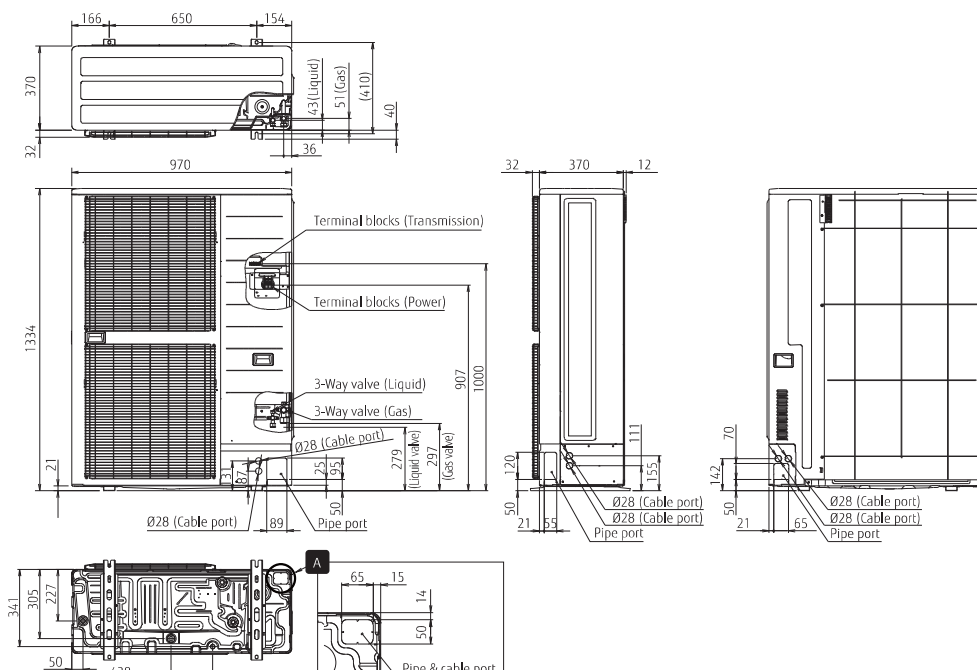

Heat Pump

for Small Capacity Type

AIRSTAGE™ J-IV

Efficiency in actual operation

Top class high COP (Max. Heating) is achieved for all models because of a large heat exchanger, highly efficient DC twin compressor.

High EER / COP (Max. Heating)

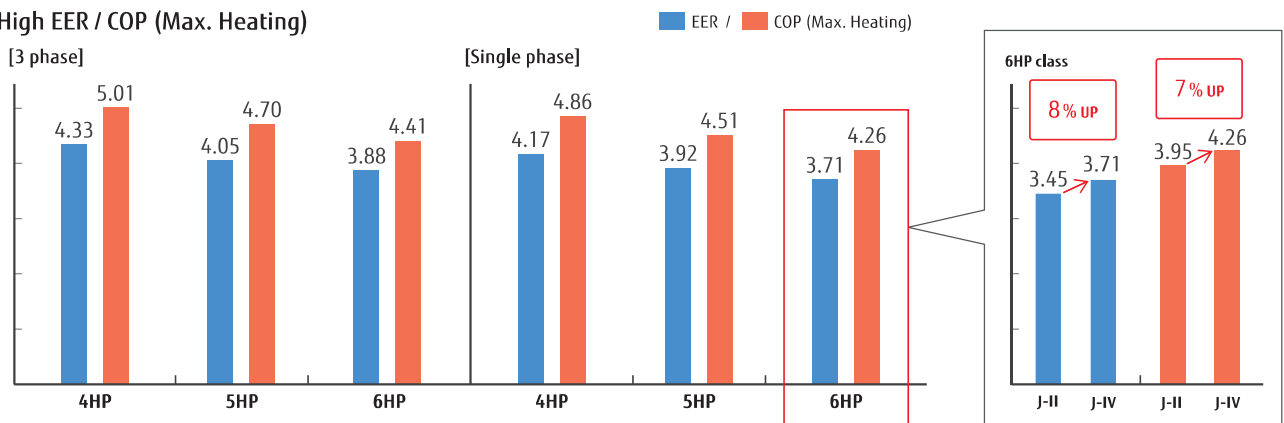

Long piping length

Our advanced refrigerant control technology allows us to achieve a total refrigerant piping length of 180 m. This opens up new possibilities in system design.

Up to 14 units* can be connected

Improvements in the design of the outdoor heat exchanger combined with our new 1.1kW indoor units mean that up to 14 indoor units can be connected.

*: 6 HP model

Model	Current model (J-III)			New model (J-IV)		
	4	5	6	4	5	6
Rating Capacity range (HP)	4	5	6	4	5	6
Max. Connectable indoor unit	1-9	1-10	1-13	1-11	1-12	1-14

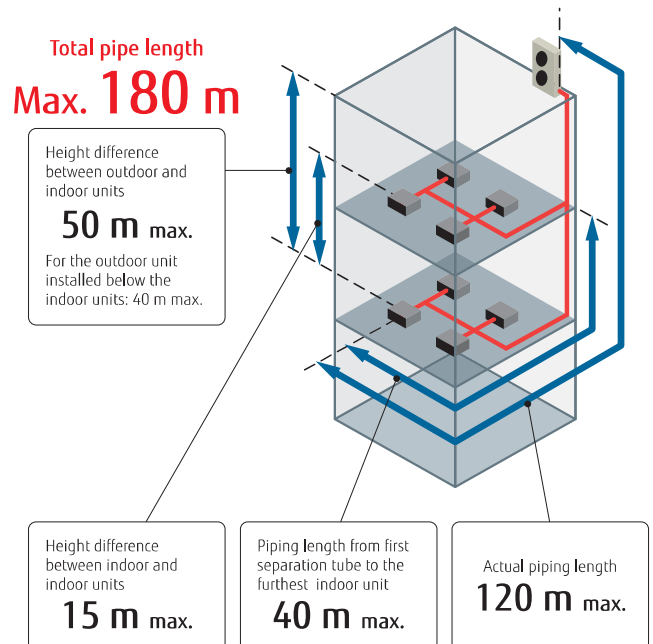

**4,5,6HP : AJY040LBLEBH / AJY045LBLEBH / AJY054LBLEBH
AJY040LELBH [3 phase] / AJY045LELBH [3 phase] / AJY054LELBH [3 phase]**



NEW

Specifications

Rating Capacity range		HP	4	5	6
Model name			AJY040LBLEBH	AJY045LBLEBH	AJY054LBLEBH
Maximum Connectable Indoor Unit			1-11	1-12	1-14
Power source			Single phase, ~230V, 50Hz		
Capacity	Cooling	kW	12.1	14.0	15.5
	Nominal Heating		12.1	14.0	15.5
	Max Heating		13.6	16.0	18.0
Input power	Cooling	kW	2.90	3.57	4.18
	Nominal Heating		2.39	2.97	3.50
	Max Heating		2.80	3.55	4.26
EER	Cooling	W/W	4.17	3.92	3.71
COP	Nominal Heating		5.06	4.71	4.43
	Max Heating		4.86	4.51	4.23
Airflow rate		m ³ /h	6,200	6,400	6,900
Sound pressure level / Power level	Cooling	dB(A)	50 / 65	51 / 65	53 / 66
	Heating		52 / 67	55 / 69	56 / 69
Heat exchanger fin			Blue fin	Blue fin	Blue fin
Net Dimensions	Height	mm	1,334	1,334	1,334
	Width		970	970	970
	Depth		370	370	370
Weight		kg	117	117	119
Refrigerant	Type (Global Warming Potential)		R410A (2,088)	R410A (2,088)	R410A (2,088)
	Charge	kg(CO ₂ eq-T)	4.8 (10.0)	5.3 (11.1)	5.3 (11.1)
Connection pipe diameter	Liquid	mm	9.52	9.52	9.52
	Gas		15.88	15.88	19.05
Total pipe length		m	180	180	180
Max. height difference			50/40 (Outdoor unit: Upper/Lower)		
Operation range	Cooling	°C	-5 to 46	-5 to 46	-5 to 46
	Heating		-20 to 21	-20 to 21	-20 to 21

Rating Capacity range		HP	4	5	6
Model name			AJY040LELBH	AJY045LELBH	AJY054LELBH
Maximum Connectable Indoor Unit			1-11	1-12	1-14
Power source			3 phase, ~400V, 50Hz		
Capacity	Cooling	kW	12.1	14.0	15.5
	Nominal Heating		12.1	14.0	15.5
	Max Heating		13.6	16.0	18.0
Input power	Cooling	kW	2.79	3.46	3.99
	Nominal Heating		2.32	2.86	3.36
	Max Heating		2.71	3.40	4.08
EER	Cooling	W/W	4.33	4.05	3.88
COP	Nominal Heating		5.21	4.90	4.61
	Max Heating		5.01	4.70	4.41
Airflow rate		m ³ /h	6,200	6,400	6,900
Sound pressure level / Power level	Cooling	dB(A)	50 / 65	51 / 65	53 / 66
	Heating		52 / 67	55 / 69	56 / 69
Heat exchanger fin			Blue fin	Blue fin	Blue fin
Net Dimensions	Height	mm	1,334	1,334	1,334
	Width		970	970	970
	Depth		370	370	370
Weight		kg	118	119	119
Refrigerant	Type (Global Warming Potential)		R410A (2,088)	R410A (2,088)	R410A (2,088)
	Charge	kg(CO ₂ eq-T)	4.8 (10.0)	5.3 (11.1)	5.3 (11.1)
Connection pipe diameter	Liquid	mm	9.52	9.52	9.52
	Gas		15.88	15.88	19.05
Total pipe length		m	180	180	180
Max. height difference			50/40 (Outdoor unit: Upper/Lower)		
Operation range	Cooling	°C	-5 to 46	-5 to 46	-5 to 46
	Heating		-20 to 21	-20 to 21	-20 to 21

Note: Specifications are based on the following conditions.

Cooling: Indoor temperature of 27°CDB/19°CWB, and outdoor temperature of 35°CDB/24°CWB.

Heating: Indoor temperature of 20°CDB/(15°CWB), and outdoor temperature of 7°CDB/6°CWB.

Pipe length: 7.5 m; Height difference between outdoor unit and indoor unit: 0 m.

The protective function may work when using it outside the operation range.

Dimensions

(Unit : mm)

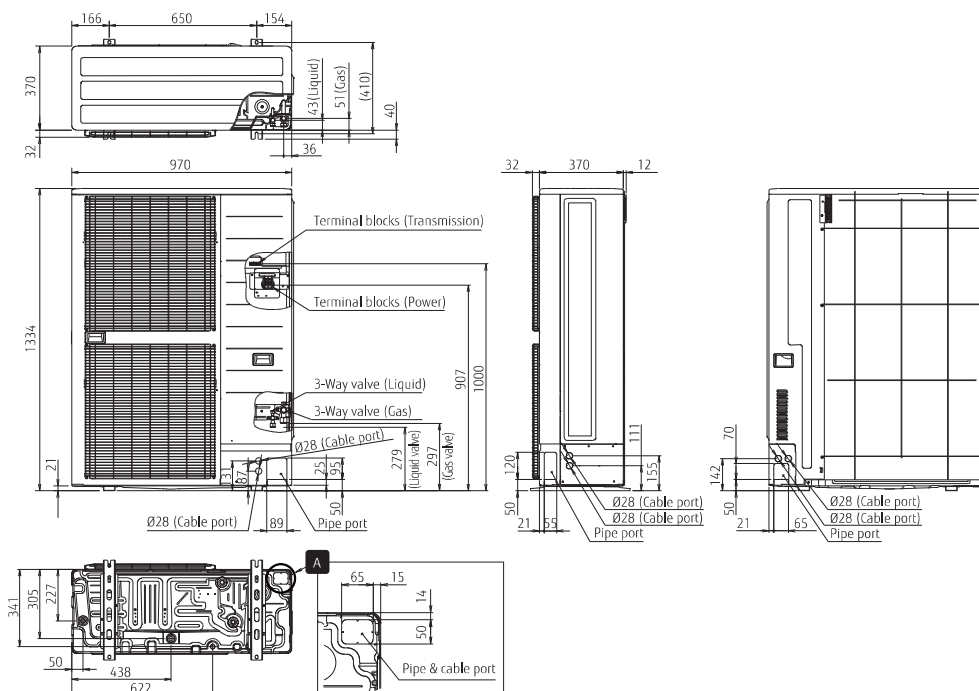

Heat Pump for Small Capacity Type

AIRSTAGE J-III L



Long Piping Length

Our advanced refrigerant control technology allows us to achieve a total refrigerant piping length of 400 m. This opens up new possibilities in system design.

Up to 40 units* can be connected

Improvements in the design of the outdoor heat exchanger combined with our new 1.1kW indoor units mean that up to 40 indoor units can be connected.

*: 16 HP model.

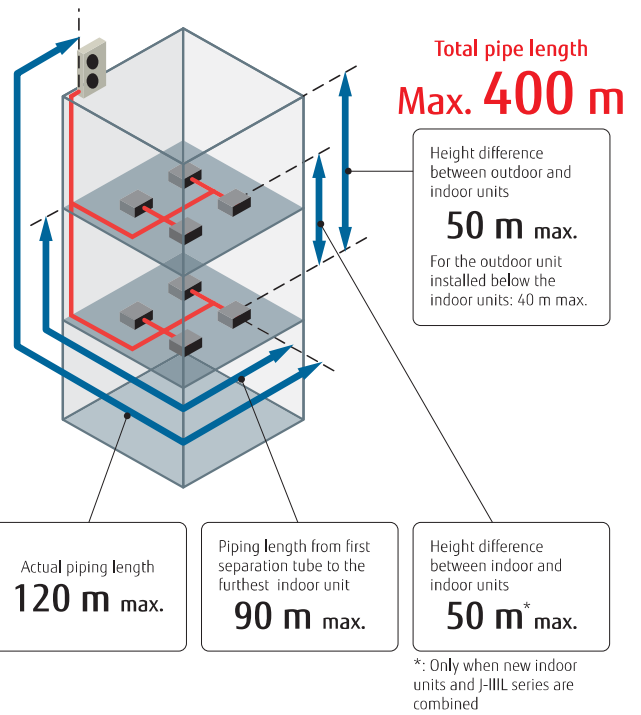
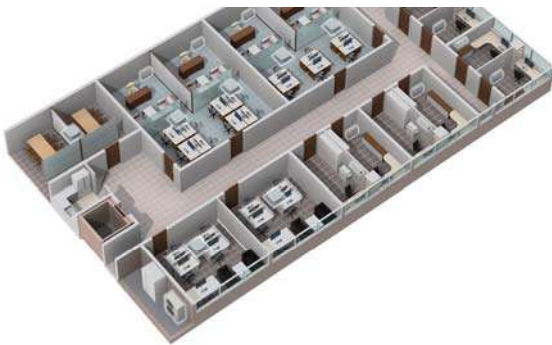

High Static Pressure

External static pressure is available up to 60Pa for 14/16HP. (20Pa for 8/10HP, 30Pa for 12HP)



Top Class Low Operating Sound

Low operating noise level make the units suitable for locations where sound levels are important.

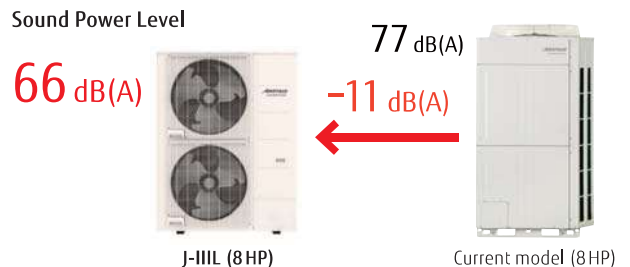

8,10,12HP: AJY072LELAH / AJY090LELAH / AJY108LELAH
14,16,18HP: AJY126LELAH / AJY144LELAH / AJY162LELAH



8, 10, 12 HP

14, 16, 18 HP

Specifications

Rating Capacity range	HP	8	10	12	14	16	18
Model name		AJY072LELAH	AJY090LELAH	AJY108LELAH	AJY126LELAH	AJY144LELAH	AJY162LELAH
Maximum Connectable Indoor Unit		1-20	1-25	1-30	1-36	1-40	1-42
Power source		3 phase, ~400V, 50Hz					
Capacity	Cooling	22.4	28.0	33.5	40.0	45.0	50.0
	Nominal Heating	22.4	28.0	33.5	40.0	45.0	50.0
	Max Heating	25.0	31.5	37.5	45.0	50.0	55.0
Input power	Cooling	6.30	8.59	10.42	12.12	14.96	18.52
	Nominal Heating	4.65	6.61	8.18	9.71	11.81	13.66
	Max Heating	5.45	8.29	10.25	11.82	14.29	16.66
EER/SEER (LOT21)	Cooling	3.56/6.72	3.26/6.48	3.22/6.72	3.30/6.33	3.01/6.16	2.70
COP/SCOP (LOT21)	Nominal Heating	4.82	4.24	4.10	4.12	3.81	3.66
	Max Heating	4.56/3.86	3.80/3.59	3.66/3.58	3.81/3.52	3.50/3.51	3.30
Airflow rate		8,400	9,000	11,000	13,000	14,000	14,800
Sound pressure level / Power level	Cooling	52/66	54/69	59/73	62/75	64/77	65/79
	Heating	54/—	57/—	61/—	63/—	65/—	68/—
Minimum Recommended MCB	AMP	20	20	25	40	40	40
Net Dimensions	Height	1,428	1,428	1,428	1,638	1,638	1,638
	Width	1,080	1,080	1,080	1,080	1,080	1,080
	Depth	480	480	480	480	480	480
Weight	kg	170	177	178	210	210	217
Refrigerant	Type	R410A					
	Charge	7.0	7.5	7.5	11.0	11.0	11.8
Connection pipe diameter	Liquid	3/8	3/8	1/2	1/2	1/2	1/2
	Gas	3/4	7/8	1 1/8	1 1/8	1 1/8	1 1/8
Total pipe length	m	400	400	400	400	400	400
Max. height difference		50/40 (Outdoor unit: Upper/Lower)					
Operation range	Cooling	-5 to 46*	-5 to 46*	-5 to 46*	-5 to 46*	-5 to 46*	-5 to 46*
	Heating	-20 to 21	-20 to 21	-20 to 21	-20 to 21	-20 to 21	-20 to 21

Note: Specifications are based on the following conditions.

Cooling: Indoor temperature of 27°CDB / 19°CWB, and outdoor temperature of 35°CDB / 24°CWB.

Heating: Indoor temperature of 20°CDB / (15°CWB), and outdoor temperature of 7°CDB / 6°CWB.

Pipe length: 7.5 m; Height difference between outdoor unit and indoor unit: 0 m.

* The cooling operation range of -15 to 46°C is allowed only when all of the indoor units connected to the system are higher than capacity of 5.6kW.

Dimensions

(Unit : mm)

8, 10, 12 HP

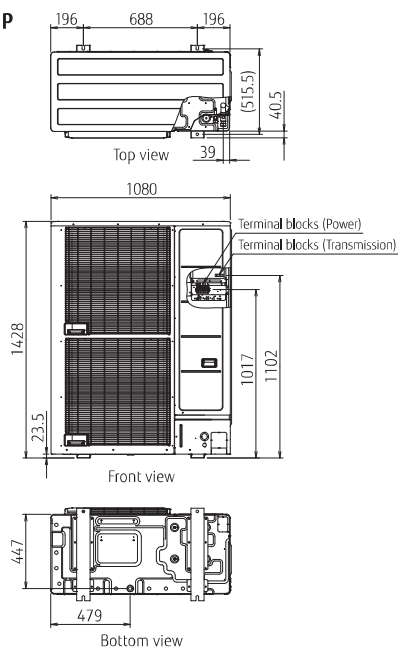

14, 16 18 HP

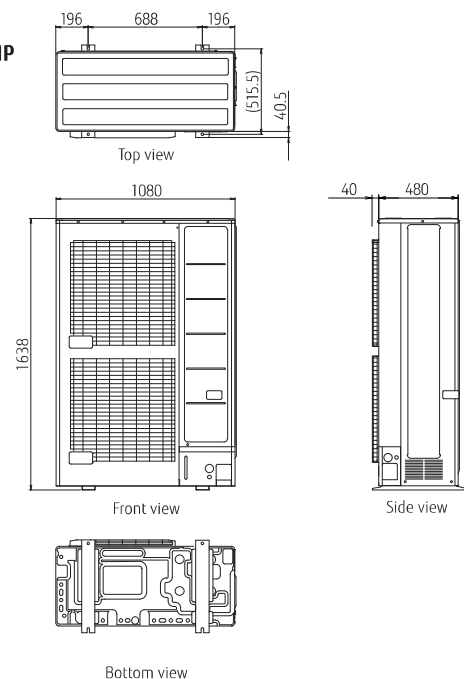

Heat Pump

for Small Capacity Type

AIRSTAGE™ J-IVL

Efficiency in actual operation

Top class high EER/COP(Max. Heating) is achieved for all models by a large heat exchanger, highly efficient Scroll compressor.

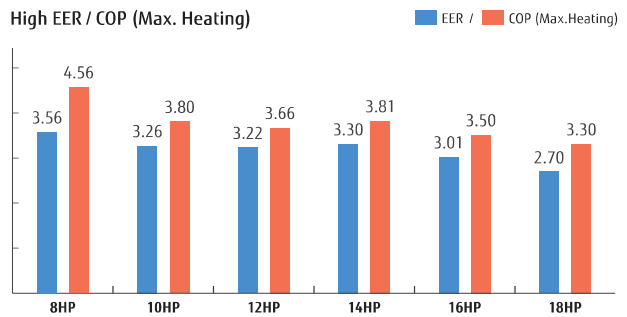

Long piping length

Our advanced refrigerant control technology allows us to achieve a total refrigerant piping length of 400 m. This opens up new possibilities in system design.

Up to 42 units* can be connected

Improvements in the design of the outdoor heat exchanger combined with our new 1.1kW indoor units mean that up to 42 indoor units can be connected.

*: 18 HP model

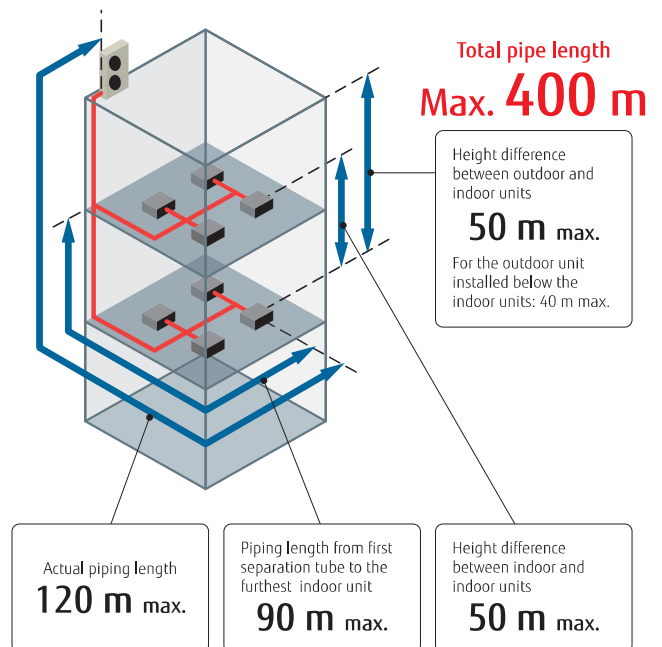

Top Class Low Operating Sound

Low operating noise level make the units suitable for locations where sound levels are important.

Sound Power Level

66 dB(A)



J-IVL (8HP)

77 dB(A)

-11 dB(A)



Current model (8HP)

8,10,12 HP: AJY072LELBH / AJY090LELBH / AJY108LELBH
 14,16,18 HP: AJY126LELBH / AJY144LELBH / AJY162LELBH



Specifications

Rating Capacity range		HP	8	10	12	14	16	18
Model name			AJY072LELBH	AJY090LELBH	AJY108LELBH	AJY126LELBH	AJY144LELBH	AJY162LELBH
Maximum Connectable Indoor Unit			1-20	1-25	1-30	1-36	1-40	1-42
Power source			3 phase, ~400V, 50Hz					
Capacity	Cooling	kW	22.4	28.0	33.5	40.0	45.0	50.0
	Nominal Heating		22.4	28.0	33.5	40.0	45.0	50.0
	Max. Heating		25.0	31.5	37.5	45.0	50.0	55.0
Input power	Cooling	kW	6.30	8.59	10.42	12.12	14.96	18.52
	Nominal Heating		4.65	6.61	8.18	9.71	11.81	13.66
	Max. Heating		5.45	8.29	10.25	11.80	14.29	16.66
EER	Cooling		3.56	3.26	3.22	3.30	3.01	2.70
COP	Nominal Heating	W/W	4.82	4.24	4.10	4.12	3.81	3.66
	Max. Heating		4.56	3.80	3.66	3.81	3.50	3.30
Airflow rate		m ³ /h	8,400	9,000	11,000/12,100	13,000	14,000	14,800/15,300
Sound pressure level / Power level	Cooling	dB(A)	52/66	54/69	59/73	62/75	64/77	65/79
	Heating		54/—	57/—	62/—	63/—	65/—	68/—
Net Dimensions	Height	mm	1,428	1,428	1,428	1,638	1,638	1,638
	Width		1,080	1,080	1,080	1,080	1,080	1,080
	Depth		480	480	480	480	480	480
Weight		kg	170	177	178	213	213	217
Refrigerant	Type (Global Warming Potential)		R410A (2,088)	R410A (2,088)	R410A (2,088)	R410A (2,088)	R410A (2,088)	R410A (2,088)
	Charge	kg(CO ₂ eq-T)	7.0 (14.6)	7.5 (15.7)	7.5 (15.7)	11.0 (22.9)	11.0 (22.9)	11.8 (24.6)
Connection pipe diameter	Liquid	mm	9.52	9.52	12.70	12.70	12.70	12.70
	Gas		19.05	22.20	28.58	28.58	28.58	28.58
Total pipe length		m	400	400	400	400	400	400
Max. height difference			50/40 (Outdoor unit: Upper/Lower)					
Operation range	Cooling	°C	-15 to 46	-15 to 46	-15 to 46	-5 to 46*	-5 to 46*	-5 to 46*
	Heating		-20 to 21	-20 to 21	-20 to 21	-20 to 21	-20 to 21	-20 to 21

Note: Specifications are based on the following conditions.

Cooling: Indoor temperature of 27°CDB / 19°CWB, and outdoor temperature of 35°CDB / 24°CWB.

Heating: Indoor temperature of 20°CDB / (15°CWB), and outdoor temperature of 7°CDB / 6°CWB.

Pipe length: 7.5 m; Height difference between outdoor unit and indoor unit: 0 m.

* The cooling operation range of -15 to 46°C is allowed only when all of the indoor units connected to the system are higher than capacity of 5.6kW.

Dimensions

(Unit : mm)

8, 10, 12 HP

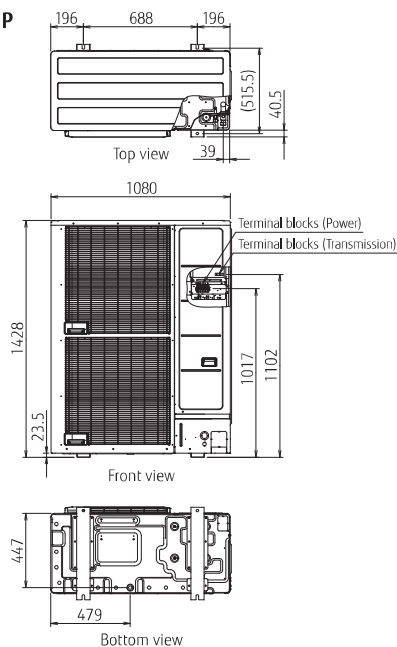

14, 16, 18 HP

