

Air to Water Heat Pump

Split system

Outdoor unit
WO*G112LCT
WO*G140LCT
WO*K112LCT
WO*K140LCT
WO*K160LCT

Hydraulic unit
WS*G140DC6
WS*K160DC9



Installation and operating manual

intended for professionals

To be saved for
future consultation

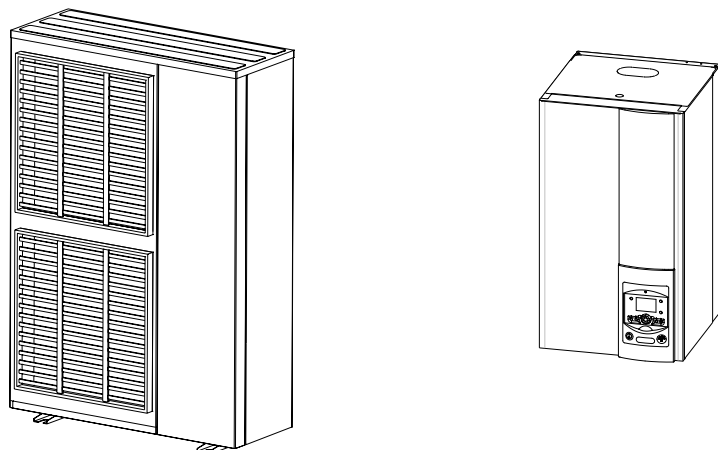

Fujitsu General (Euro) GmbH
Wertstrasse 20
40549 Düsseldorf - Germany

Subject to modifications without notice.
Non contractual document.

☞ **This device requires for its installation, the intervention of qualified personnel with a certificate of capacity for handling refrigerants.**

Contents

Description of the unit	4		
Package	4	Description.	9
Definitions	4	Operating principle	10
Specifications	5		
Installation	12		
Regulation installation and maintenance conditions	12	Hydraulic connecting	22
Unpacking and reservations	12	General	22
Receipt	12	Rinsing out the installation	22
Handling	12	Filling and purging the installation	22
Accessories provided	12	Connecting the Fan convector circuit.	22
Installation position	12	Heating circulation pump speed settings	23
Installation of the outdoor unit	12	Electrical connections	24
Installation precautions	12	Characteristic of the electrical supply.	24
Outdoor unit positioning	14	General remarks on electrical connections.	24
Condensate drain hose	14	Overview of all the electrical connections	25
Installing the hydraulic unit	15	Cable section and protection rating.	25
Installation precautions	15	Electrical connections	
Positioning the hydraulic unit	15	on the single phase outdoor unit side.	26
Refrigeration connections	16	Electrical connections	
Rules and precautions	16	on the 3- phase outdoor unit side.	27
Refrigeration connections.	16	Electrical connections	
Accessing the hydraulic module's		on the hydraulic unit side	28
refrigerant connections	17	Outdoor sensor	31
Creating the flarings	17	Room thermostat and/or remote control.	31
Shaping the refrigeration pipes	17	Installing a room sensor.	31
Connecting the flared connections	18	Installing a remote control.	31
Filling the installation with gas	19	Commissioning	31
Example of commissioning procedure	19	Configuring room thermostat	32
Sealing test	19	Configuring remote control (wireless)	32
Additional charge	20		
Pump down operation (Refrigerant collecting			
operation) single phase outdoor unit	20		
Pump down operation (Refrigerant collecting			
operation) 3-phase outdoor unit	21		

Regulation system	34
User interface, Remote control (option) and Room thermostat (option).	34
Description of the display	36
Temperature control	36
Set to	36
Parametering the setting	38
General	38
Setting parameters	38
List of function lines (settings, diagnosis, status).	38

Overall hydraulic layout	50
---	-----------

Electrical wiring diagrams	52
---	-----------

Troubleshooting	56
Faults displayed on the hydraulic unit	56
Information display	57
Faults displayed on the single phase outdoor unit	58
Faults displayed on the 3-phase outdoor unit	59

Quick-start procedure	60
Start-up check-list	60
Before starting-up.	60
Starting-up	61
Settings sheet	62
Start-up data sheet	63

Instructions for the user	64
--	-----------

Packing list

Heat Pump	Outdoor Unit	Hydraulic Unit
Model	Reference	Reference
Waterstage High Power 11 single phase	WO*G112LCT	WS*G140DC6
Waterstage High Power 14 single phase	WO*G140LCT	
Waterstage High Power 11 3-phase	WO*K112LCT	WS*K160DC9
Waterstage High Power 14 3-phase	WO*K140LCT	
Waterstage High Power 16 3-phase	WO*K160LCT	

Optional equipment

- **2nd circuit kit** (code UTW-KZS*D)
for connecting 2 heating circuits.
- **Regulation extension kit** (code UTW-KRE*D)
to manage a 2nd heating circuit, swimming pool etc...
- **DHW kit** (code UTW-KDW*D)
for connecting a DHW tank
(with built-in electrical back-ups).
- **Boiler connection kit** (code UTW-KBS*D)
for connecting a boiler to the heat pump.
- **Room thermostat** (code UTW-C55*A),
Wireless room thermostat (code UTW-C58*D)
for correcting the ambient temperature.
- **Remote control** (code UTW-C75*A),
Wireless remote control (code UTW-C78*D)
for correcting the ambient temperature and
programming the heat pump.
- **Swimming pool kit** (code UTW-KSP*D).
- **Cooling kit** (code UTW-KCL*D).
- **High flow rate circulating pump kit** (code UTW-PHF*D)
for the installation of 1 circuit floor heating
(with model > 13 kW).

Scope of application

This heat pump provides:

- Heating in winter,
- Control of two heating circuits*,
- Production of domestic hot water* (provided that combined with a DHW tank).
- Installation with boiler connection* as a supplementary heating for the coldest days.
- Cooling in summer* (for floor heating-cooling system or fan-convectors).
- Heating the swimming pool*.

* : These options require the use of additional kits (see para "Optional equipment").

1 Description of the unit

1.1 Package

- **1 package**: Outdoor unit.
- **1 package**: Hydraulic unit and outdoor sensor.

1.2 Definitions

- **Split**: The heat pump consists of two elements (an outdoor unit for outdoor and a hydraulic unit for inside the dwelling).
- **Air/water**: The surrounding air is the energy source. This energy is transmitted to the water in the heating circuit by the heat pump.
- **Inverter**: the fan and compressor speeds are modulated according to the heating requirements. This technology enables you to save on energy and operate on a single-phase power supply, whatever the heat pump's output, by avoiding heavy intensities on start-up.
- **COP** (coefficient of performance): this is the relationship between the energy transmitted to the heating circuit and electrical energy consumed.

1.3 Specifications

Designation model	Waterstage High Power	11 Single phase	14 Single phase	11 3-Phase	14 3-Phase	16 3-Phase
Nominal heating performances (outdoor temperature / initial temperature)						
Heat output						
+7 °C / +35 °C - Floor heating system	kW	10,80	13,50	10,80	13,50	15,17
-7 °C / +35 °C - Floor heating system	kW	10,80	12,00	10,80	13,00	13,50
+7 °C / +45 °C - Low temperature radiator	kW	9,23	11,54	10,10	12,60	13,00
-7 °C / +45 °C - Low temperature radiator	kW	9,16	11,45	10,02	12,50	13,00
+7 °C / +55 °C - Radiator	kW	7,74	9,67	9,48	11,80	12,96
-7 °C / +55 °C - Radiator	kW	7,51	9,25	9,20	10,60	11,90
Power absorbed						
+7 °C / +35 °C - Floor heating system	kW	2,54	3,23	2,51	3,20	3,70
-7 °C / +35 °C - Floor heating system	kW	4,32	5,08	4,28	5,18	5,40
+7 °C / +45 °C - Low temperature radiator	kW	2,84	3,72	3,01	3,81	4,00
-7 °C / +45 °C - Low temperature radiator	kW	4,58	5,92	4,63	6,00	6,37
+7 °C / +55 °C - Radiator	kW	3,13	4,03	3,60	4,61	5,14
-7 °C / +55 °C - Radiator	kW	4,56	5,65	5,08	6,04	6,88
Coefficient of performance (COP)	(+7 °C / + 35 °C)	4,25	4,18	4,30	4,22	4,10
Electrical characteristics						
Supply voltage (50 HZ)	V	230		400		
Maximum current for appliance	A	22	25	8,5	9,5	10,5
Nominal current	A	11,4	14,2	3,7	4,8	5,5
Maximum current of the electrical back-ups	A	26,1		13		
Power of the electrical back-ups	kW	ajustable 3 or 6 kW (phase)		9 kW (3-phase)		
Real power absorbed - by the fan	W	2x100		2x104		
- by the circulation pump	W	70				
Maximum power absorption by the outdoor unit	W	5060	5750	5865	6555	7245
Hydraulic circuit						
Maximum operating pressure	bar	3				
Hydraulic system flow rate (mini/maxi) 4°C<Δt<8°C (nominal conditions)	l/h	1170 / 2340	1460 / 2920	1170 / 2340	1460 / 2920	1650 / 3290
Various						
Weight of outdoor unit	kg	92		99		
Noise level at 1 m ¹ (hydraulic unit)	dB	39				
Sound power level according to EN 12102 ² (hydraulic unit)	dB	46				
Noise level at 5 m ¹ (outdoor unit)	dB	42	43	39	41	42
Sound power level according to EN 12102 ² (outdoor unit)	dB	69	70	66	68	69
Weight of hydraulic unit (empty / full of water)	kg	44 / 60				
Water capacity of the hydraulic unit	l	16				
Heating system operating limits						
Hydraulic unit operation range	°C	0 / +45				
Outdoor temperature mini/maxi	°C	-25 / +35				
Initial max. heating water temperature Floor heating system	°C	45				
Initial max. heating water temperature Low temperature radiator	°C	60				
Flow min. heating water temperature	°C	8				
Refrigeration circuit						
Diameter of gas pipes	inches	5/8				
Diameter of liquid pipes	inches	3/8				
Factory charge of refrigerant R410A ³	g	2500				
Maximum operating pressure	bar	42				
Minimum length of pipes	m	5				
Maximum length of pipes ⁴	m	15				
Maximum length of pipes ⁵	m	20				
Maximum level difference ⁵	m	15				

¹ Sound pressure level in (x)m of the device, 1,5m of the ground, the open field.

² The sound power level is a laboratory measure of the emitted sound power but contrary to the noise level, it doesn't correspond to the measure of the felt.

³ Refrigerant R410A (as per the standard EN 378.1).

⁴ Factory charge of refrigerant R410A.

⁵ Taking into account the possible additional load of refrigerant R410A (see page 20).

**Outside unit,
Model High Power
11 & 14 single phase**

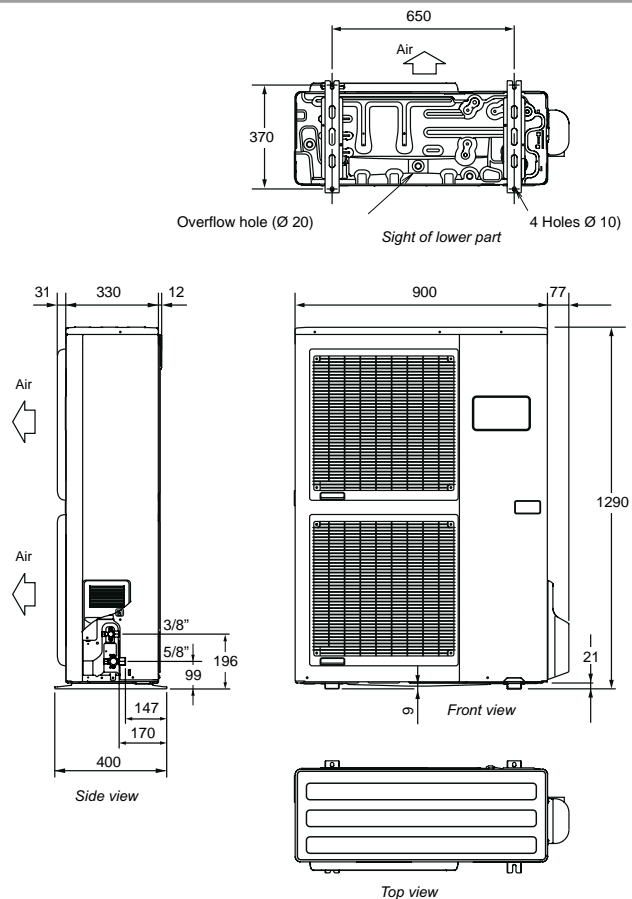

**Outside unit,
Model High Power
11, 14 & 16 3-phase**

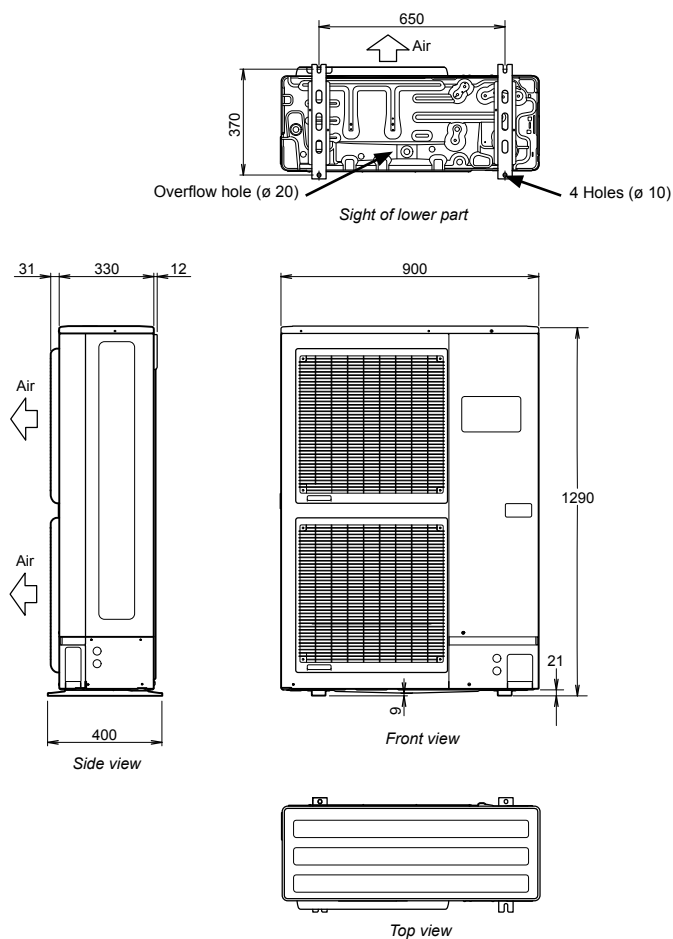

figure 1 - Dimensions in mm

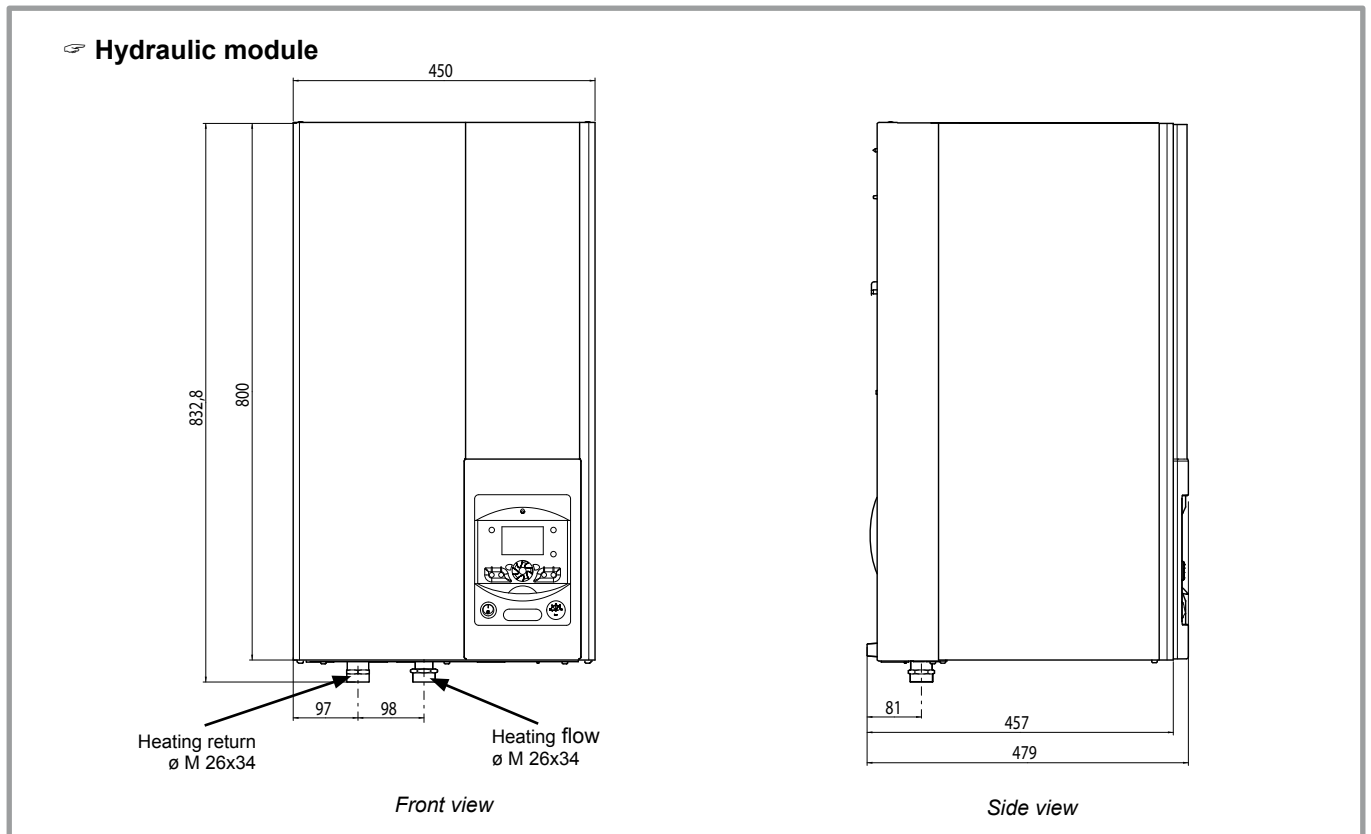

figure 2 - Dimensions in mm

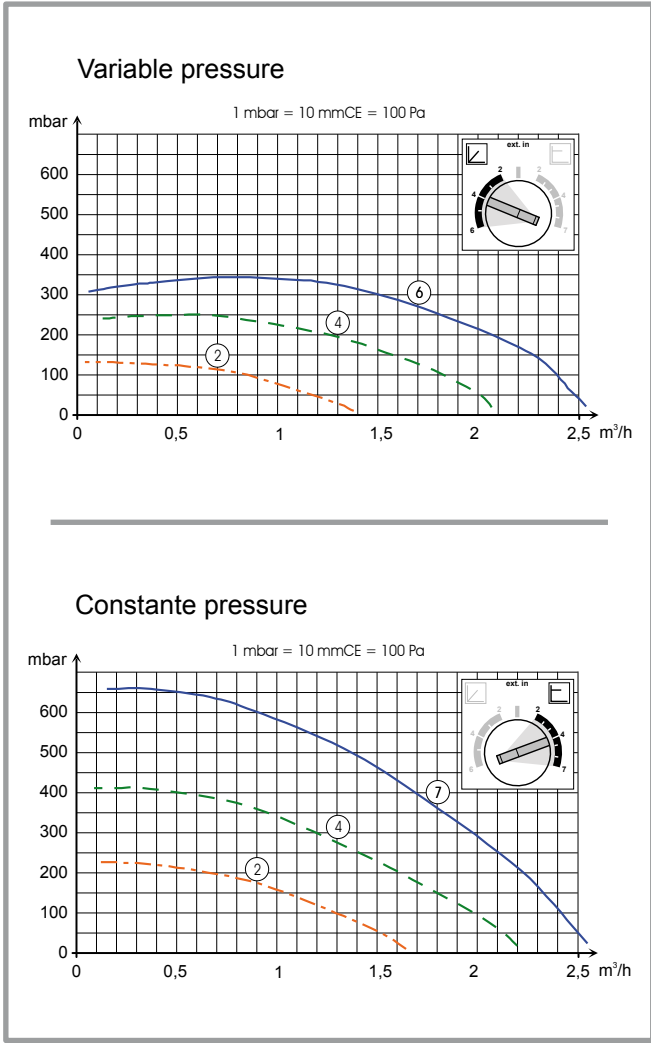

figure 3 - Hydraulic pressures and flow rates available

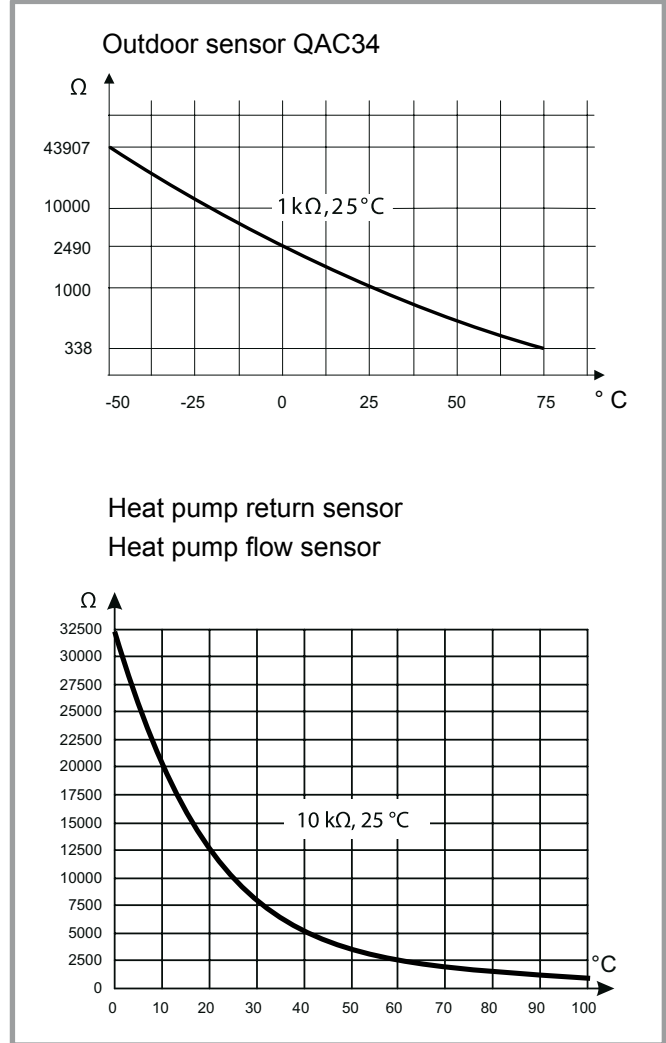

figure 4 - Ohmic values of the sensors (Hydraulic module)

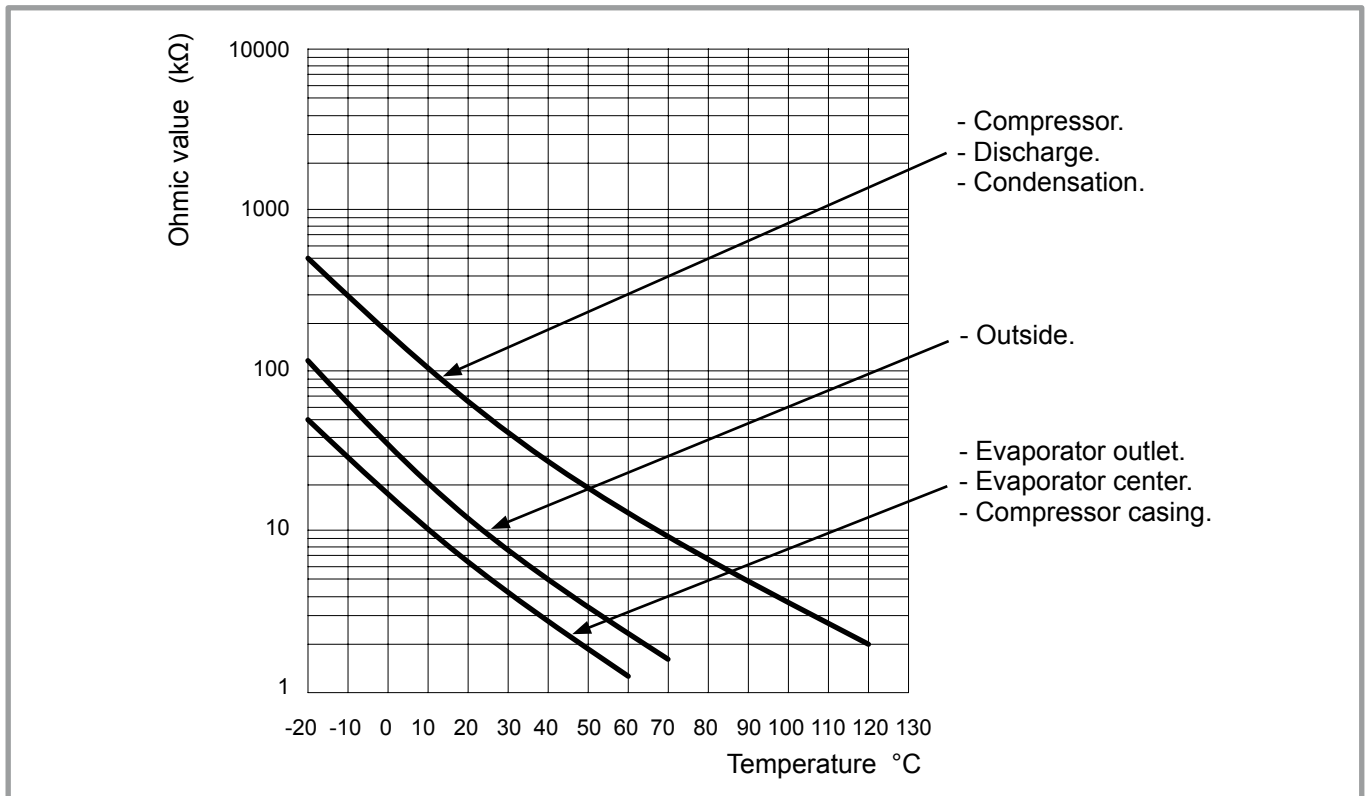

figure 5 - Ohmic values of the sensors (outside unit)

1.4 Description

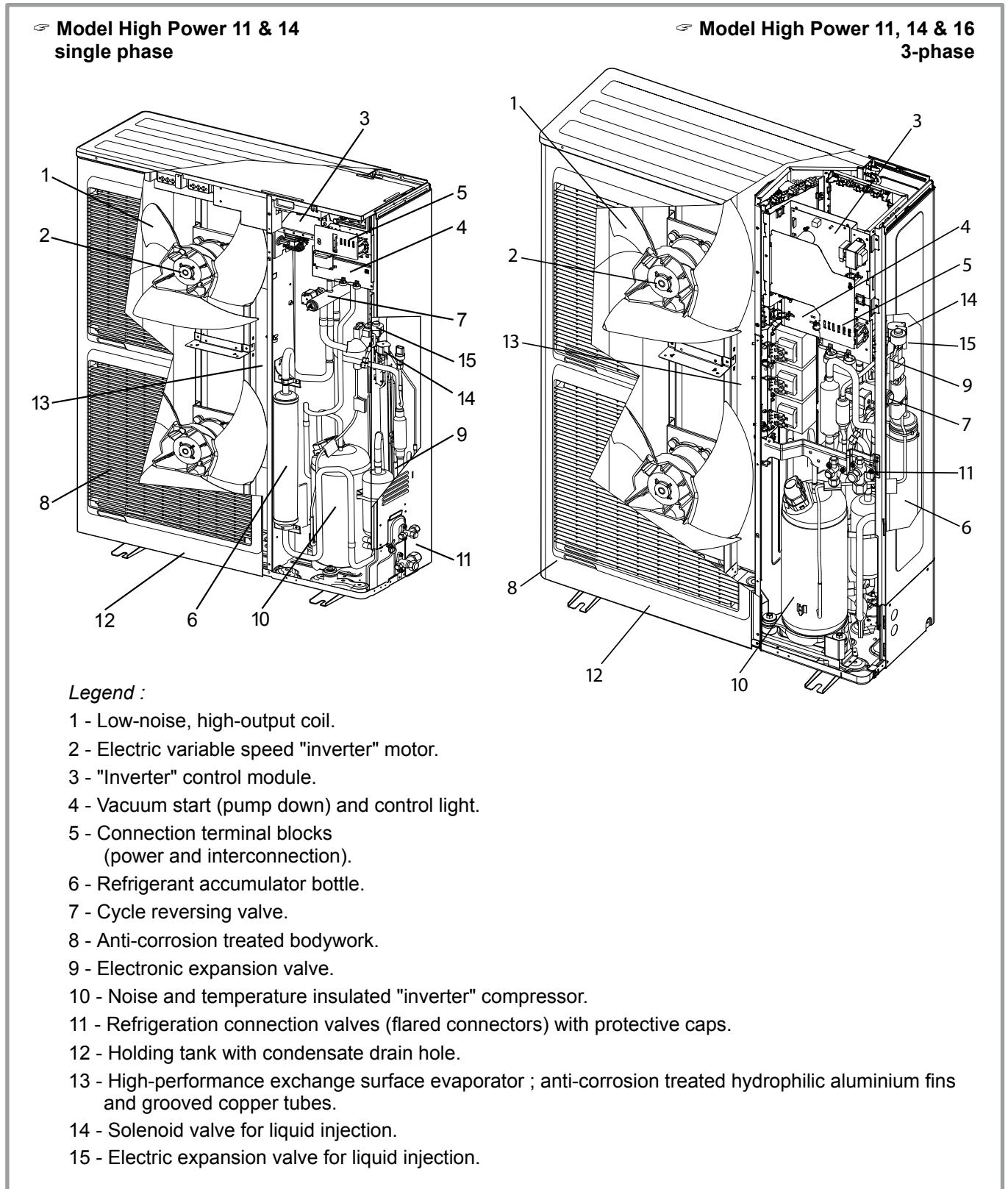

figure 6 - Outdoor unit components

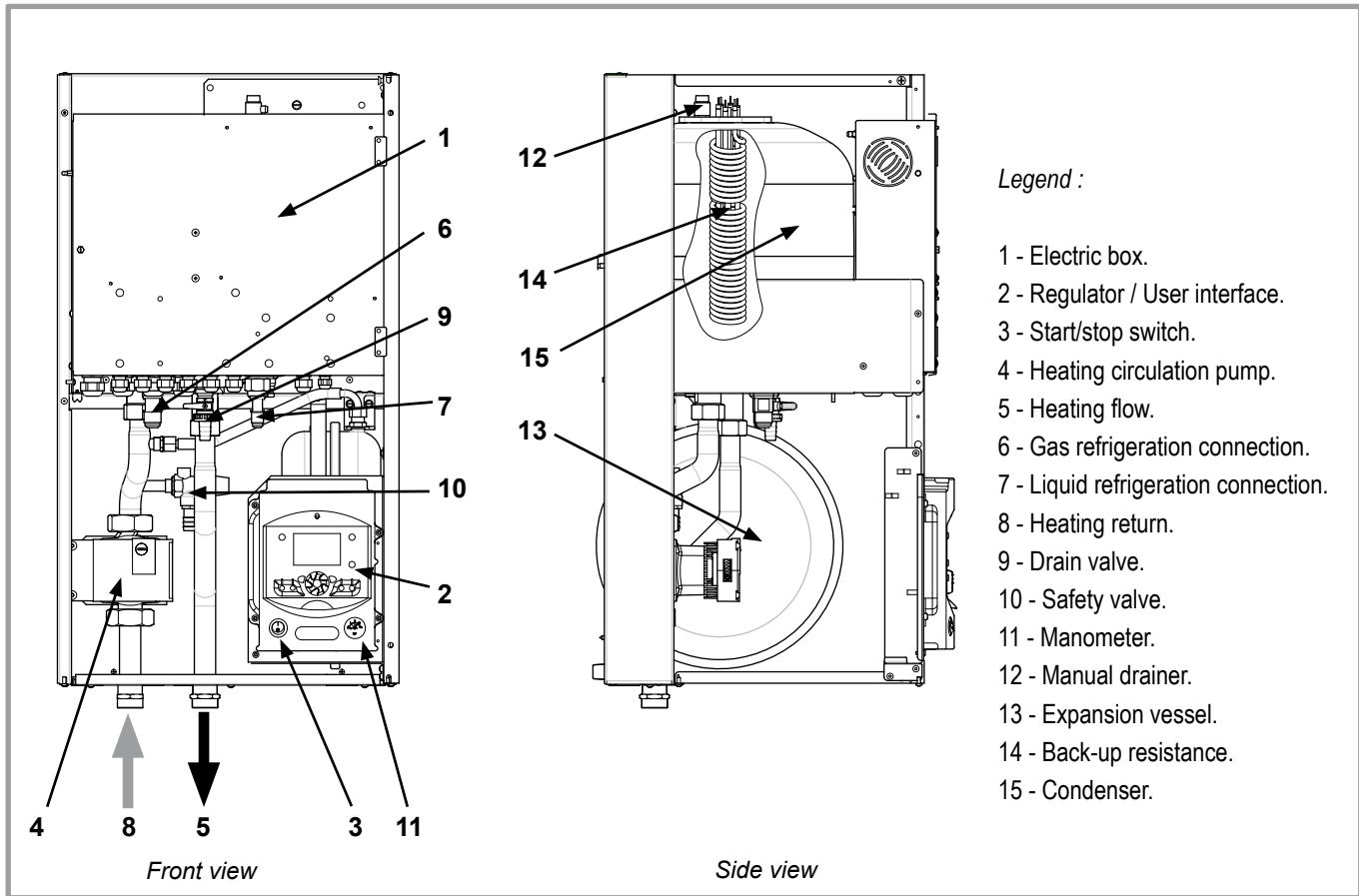

figure 7 - Hydraulic unit components

1.5 Operating principle

The heat pump transmits the energy contained in the surrounding air into the dwelling to be heated.

The heat pump consists of four main elements, in which a refrigerant fluid (R410A) circulates.

- In the evaporator (ref. **13**, figure 6, page 9) : The energy is taken from the surrounding air and is transmitted to the refrigerant. Because it has a low boiling point, it changes from the liquid state to the vapour state, even in cold weather (down to $-15\text{ }^{\circ}\text{C}$ outdoor temperature).
- In the compressor (ref. **10**, figure 6, page 9) : The vaporised refrigerant brought to high pressure and takes on more calories.
- In the condenser (ref. **14**, figure 7, page 10) : The energy in the refrigerant is transmitted to the heating circuit. The refrigerant returns to liquid state.
- In the expansion valve (ref. **9**, figure 6, page 9) : The liquefied refrigerant is brought back to low pressure and returns to its initial temperature and pressure.

The heat pump is equipped with a controller, which controls the room temperature based on the outdoor temperature measurement and governed by the temperature control. The room thermostat (option) provides a corrective action for the temperature control.

The hydraulic unit is fitted with an electrical back-up system or, optionally, boiler connection which starts up in order to provide additional heating during the coldest periods.

• Regulation functions

- The heating circuit's initial temperature is controlled by the temperature control.
- The power of the outdoor unit is modulated according to flow heating temperature via the "inverter" compressor.
- Control of the electrical back-up heating.
- The daily timer program enables you to define the periods for comfortable or reduced ambient temperature.
- Summer/winter mode switchover is automatic.
- Control of the supplementary boiler* (options).
- The room thermostat (option)*: provides a corrective action for the temperature control.
- Control of a second heating circuit*.
- Domestic hot water*: Heating time program, control of the operation of the DHW circulation pump.
- Managing the cooling*.
- Control of swimming pool heating*.

* If the heat pump is equipped with optional equipment and the associated kits.

• Protection functions

- Anti-legionella cycle for domestic hot water.
- Frost protection: Frost protection cuts in if the low-temperature point of the heating circuit falls below $5\text{ }^{\circ}\text{C}$ (provided that the heat pump's electrical power supply is not interrupted).

• Domestic hot water (DHW) operating principle

Two domestic hot water (DHW) temperatures can be parametered: nominal temperature (line 1610 to 55 °C) and reduced temperature (line 1612 to 40 °C).

The default heat pump program (line 560, 561 and 562) is set for nominal temperature from 0:00 to 5:00 and from 14:30 to 17:00 and for reduced temperature for the rest of the day. This optimizes electrical consumption while ensuring comfortable availability of hot water.

Setting for reduced temperature can be useful to prevent the DHW from switching on too often and for too long during the day.

The production of domestic hot water (DHW) is triggered when the temperature in the tank falls 7°C (setting from line 5024) below the set temperature.

The heat pump produces the domestic hot water, which is then additively heated, if required, by electrical back-up heating inside the tank. To ensure a DHW setting over 45°C, the electrical back-up heating or the boiler must be left on.

Depending on how the parameter (1620) is set, nominal temperature can be reached 24h/day or only at night or depending on the heat pump program.

If the contract concluded with the energy provider includes a subscription to day/night tariff, the electrical backup is subordinate to the supplier's power tariff and the comfort temperature may only be reached at night.

If no particular contract is concluded, the comfort temperature can be reached at any time, including during the day

The production of DHW takes priority over heating; nevertheless the production of DHW is controlled by cycles that control the times assigned to the heating and the production of DHW in the event of simultaneous demand.

A function to switch from "reduced" to "nominal" is provided on the front of the user interface. (see ref. 5, figure 34, page 34).

Anti-legionella cycles can be programmed.

• Fan convectors with integrated control system

Do not use a room sensor in the area.

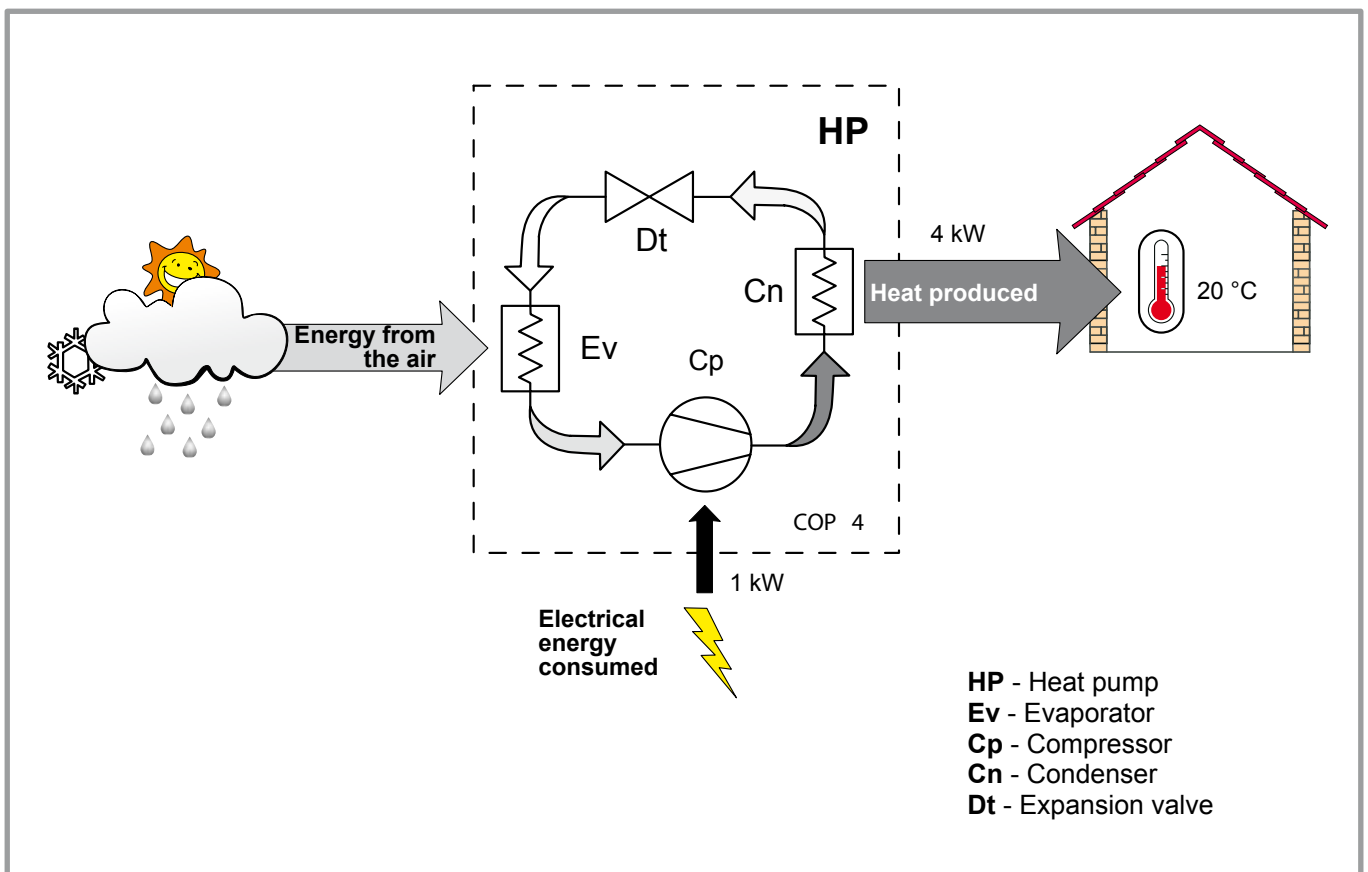

figure 8 - Heat pump operating principle

2 Installation

2.1 Regulation installation and maintenance conditions

The appliance must be installed and the maintained by an approved professional in accordance with the prevailing regulations and code of practice, in particular:

- The legislation on the handling of refrigerants.
- Heating installation with floor heating system.
- Low voltage electrical installations - Rules.

2.2 Unpacking and reservations

2.2.1 Receipt

Carefully check, in the carrier's presence, the general appearance of the appliances and check that the outdoor unit is not laid on its side or back.

In the case of any dispute, state any appropriate reservations to the carrier in writing within 48 hours and send a copy of this letter to the After-Sales service.

2.2.2 Handling

The outdoor unit should not be laid on its side or back during transport.

If not kept upright during transport, the appliance could be damaged through displacement of the refrigerant and deformation of the compressor suspension.

Any damage caused by transportation of the unit lying down is not covered by the warranty.

If necessary the outdoor unit may be tilted only during manual handling (to go through a door or use a staircase). This operation must be conducted very carefully and the appliance must be immediately restored to upright position.

2.2.3 Accessories provided

Accessories provided with the outdoor unit (figure 9).

Accessories provided with the hydraulic unit (figure 10).

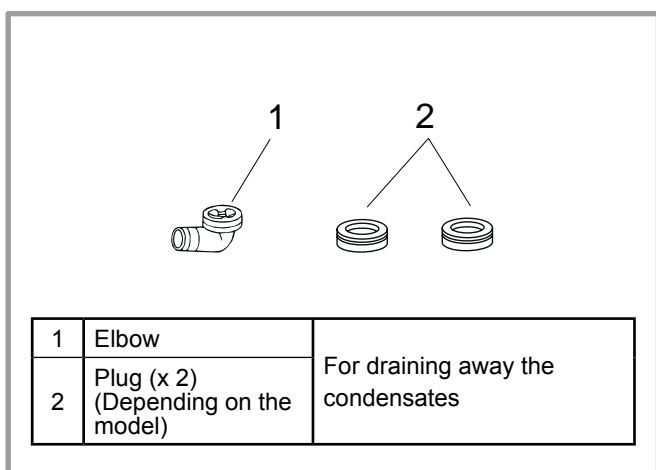

figure 9 - Accessories provided with the outdoor unit

2.3 Installation position

The choice of the position for installation is particularly important insofar as any later movement is a delicate operation requiring the intervention of a qualified person.

Choose the site of the outdoor unit and the hydraulic unit after discussion with the customer.

Observe the maximum and minimum distances between the hydraulic unit and the outdoor unit (figure 15, page 18), the guarantee of the performances and the system's service life depend on this.

2.4 Installation of the outdoor unit

2.4.1 Installation precautions

☞ **The outdoor unit must only be installed outdoor (outdoors). If a shelter is required, it must have broad openings on the 4 walls and observe the installation clearances (figure 11).**

- Choose a site that is preferably sunny and sheltered from strong cold predominant winds (mistral, tramontana, etc...).
- The unit must be easily accessible for future installation and maintenance work (page 15).
- Ensure that it is possible to make the connections to the hydraulic unit easily.
- The outdoor unit is able to withstand bad weather but avoid installing in a position where it is likely to be exposed to significant dirt or flowing water (under a defective gutter for example).
- Water may drain away from the outdoor unit when it is operating. Do not install the appliance on a paved terrace; choose a well-drained place (e.g. gravel or sand). If the installation is in an area where the temperature can be lower than 0°C for a long period, check that the presence of ice does not present any danger. A drainage pipe can also be connected to the outdoor unit (see figure 12, page 14).

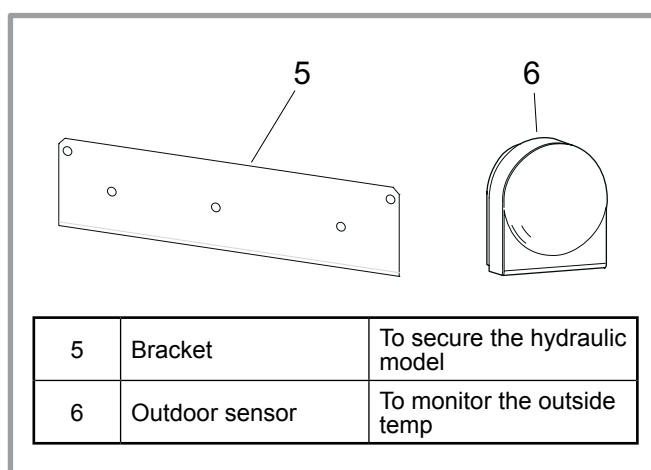

figure 10 - Accessories provided with the hydraulic unit

- Nothing should obstruct the air circulation through the evaporator and from the fan (**figure 11**).
- Keep the outdoor unit away from heat sources and inflammable products.
- Make sure the appliance not disturb the surrounding area or users (noise level, draught generated, low temperature of the air being blown out, with the risk of freezing plants in its path).
- The surface on which the appliance is installed must:
 - be permeable (soil, gravel, etc),
 - support its weight easily,
 - provide a solid fixing and
 - not transmit any vibration to the dwelling. (Anti-vibratory blocks are available as an option).
- The wall brackets is strongly discouraged due to vibration.

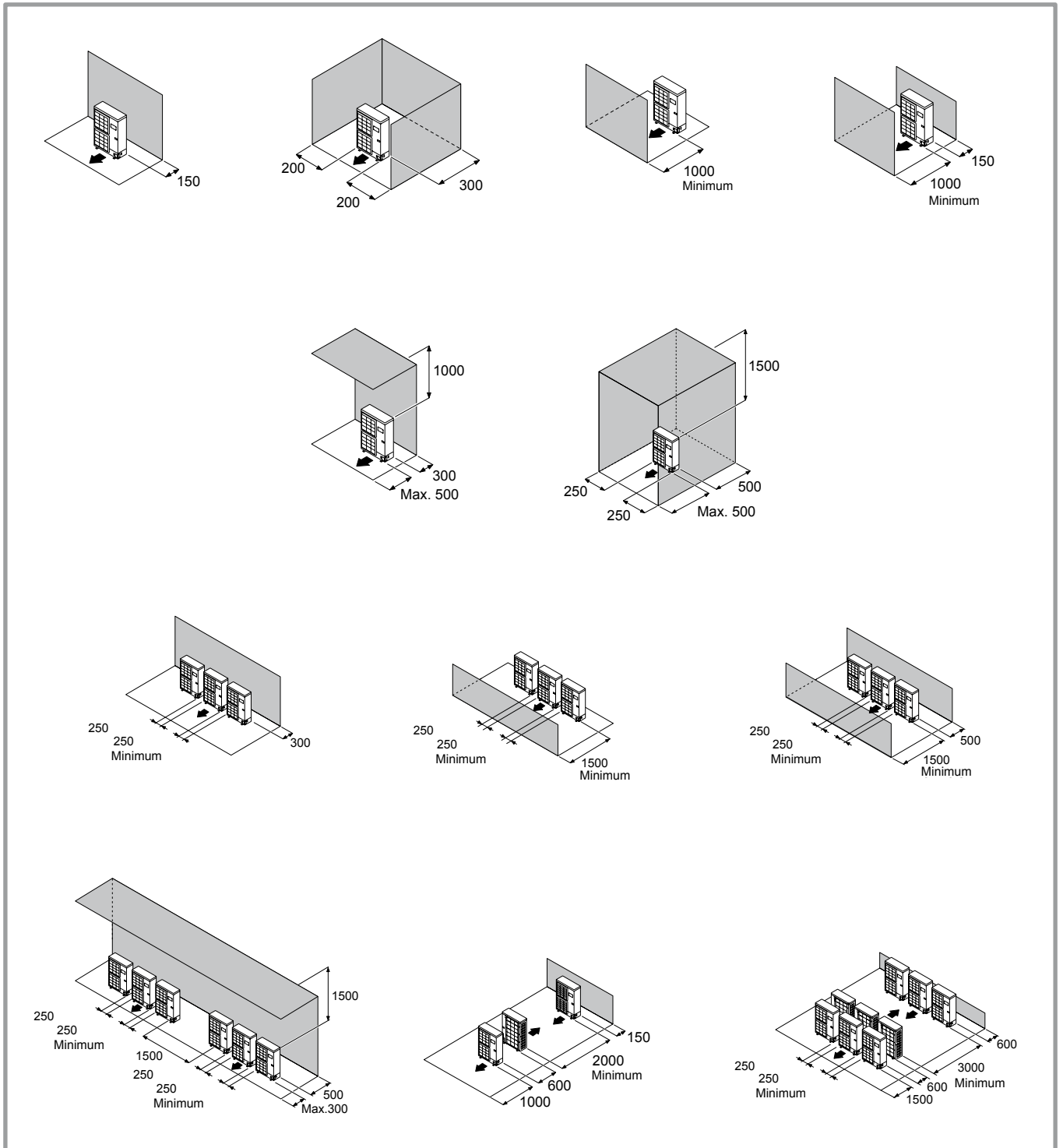

figure 11 - Minimum installation clearances around outside unit (all models)

2.4.2 Outdoor unit positioning

The outdoor unit must be raised at least 50 mm above ground level. In areas prone to snow, this height should be increased but should not exceed 1,5 m (figure 12).

- Fasten the outdoor unit by means of screws and rubber tightening or toothed lock washers to avoid their coming loose.

⚠ Warning

In the area with heavy snowfall, if the intake and outlet of outdoor unit is blocked with snow, it might become difficult to get warm and it is likely to cause of the breakdown.

Please construct a canopy and a pedestral or place the unit on high stand (local configured).

- Set the unit on a strong stand, such as one made of concrete blocks to minimize shock and vibration.
- Do not set the unit directly on the ground because it will cause trouble.

2.4.3 Condensate drain hose

(see figure 12).

If the use of a discharge pipe is imperative:

- Use the elbow provided (C) to connect a 16mm-diameter hose for draining away the condensate.
- Use the stopper or stoppers provided (B) to block the opening of the condensate tank.

Allow for the condensate to flow away under the force of gravity (waste water, rain water, gravel bed).

- ⚠ **If the installation is made in an area where the temperature can be lower than 0°C for a long period, provide the drain pipe with a trace resistance to avoid it icing up. The trace resistance must heat not only the pipe but also the bottom of the appliance's condensate collection tank.**

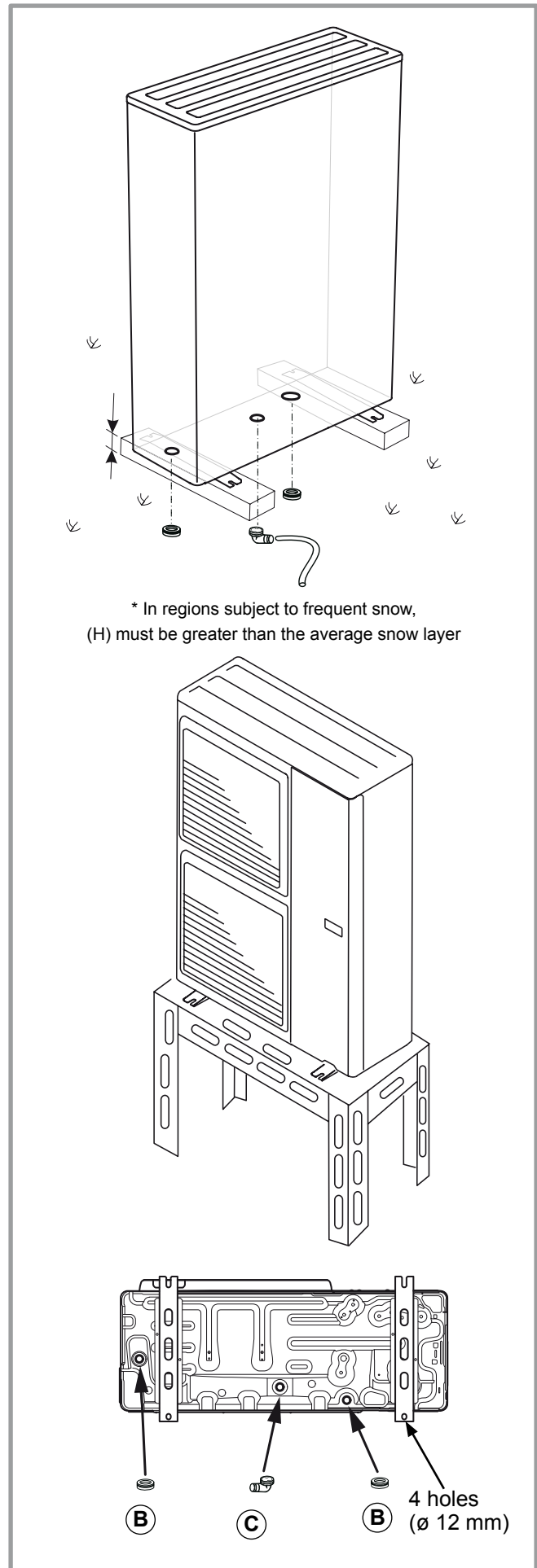
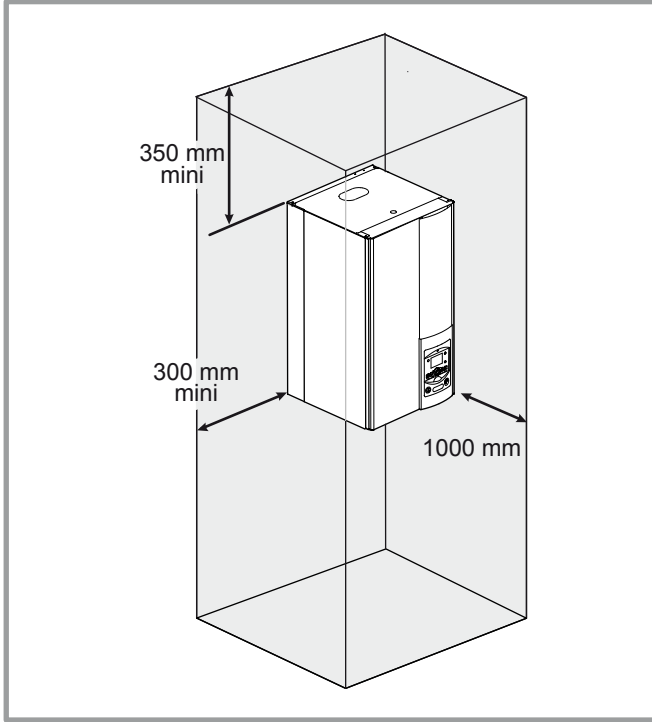

figure 12 - Positioning of the outside unit, draining away the condensate

2.5 Installing the hydraulic unit

2.5.1 Installation precautions

- The room in which the appliance operates must comply with the prevailing regulations.
- To facilitate maintenance and to allow access to the various components, we recommend that you provide sufficient space all around the hydraulic unit.



- Be careful not to bring inflammable gas near to the heat pump during its installation, in particular when it requires brazing. The appliances are not fireproof and should therefore not be installed in a potentially explosive atmosphere.

2.5.2 Positioning the hydraulic unit

- Fix the support solidly (4 screws and plugs) to a flat, hard-wearing wall (not a light partition) ensuring that it is correctly levelled.
- Hook the appliance onto its support.

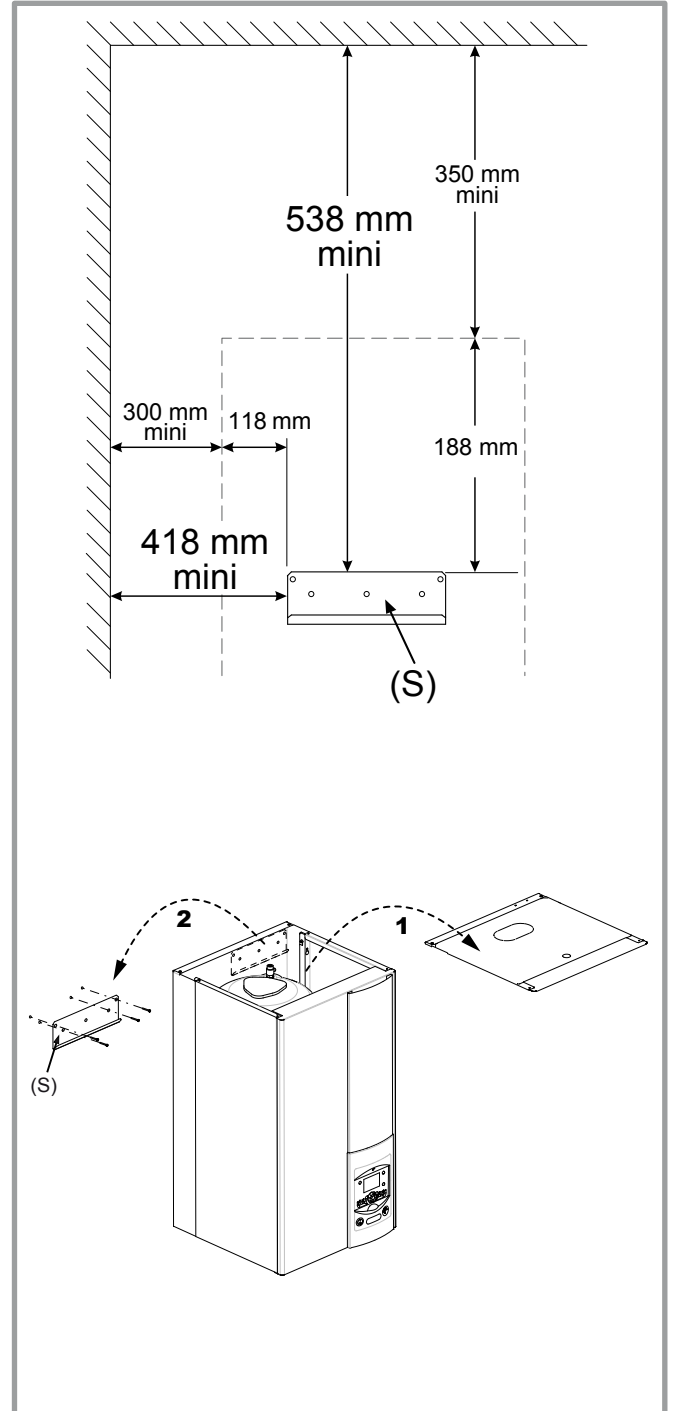

figure 13 - Mounting bracket

2.6 Refrigeration connections

☞ **This appliance uses refrigerant R410A.**

Comply with the legislation for handling refrigerants.

2.6.1 Rules and precautions

- After every intervention on the refrigeration circuit and before final connection, take care to replace the plugs in order to avoid any pollution from the refrigeration circuit.

• Tools

- Set of manometers with hoses exclusively reserved for HFCs (Hydrofluorocarbons).
- Vacuum pump specially for HFCs.
- Provision on using tools that have been in contact with HCFCs (R22 for example) or CFCs.
- Use of a traditional vacuum pump is authorized if, and only if, it is fitted with a non-return valve on the suction side.

The manufacturer declines any liability with regard to the guarantee if the above instructions are not observed.

• Flared connections

☞ **Lubrication with mineral oil (for R12, R22) is forbidden.**

- Only lubricate with polyolester refrigeration oil (POE). If POE is not available, fit without lubrication.

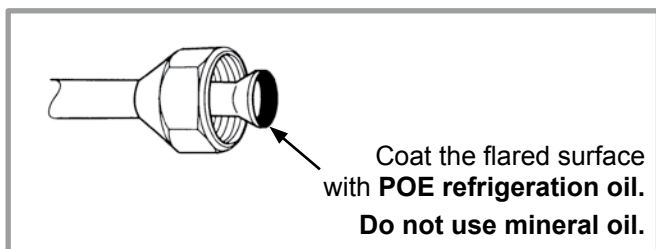

• Brazing on the refrigeration circuit (if necessary)

- Silver brazing (40% minimum recommended).
- Brazing only under dry nitrogen internal flux.
- To eliminate any filings in the pipes, use dry nitrogen to avoid introducing any humidity that may adversely affect the appliances operation. In general, take every precaution to avoid humidity penetrating into the appliance.
- Proceed to insulate the gas and liquid pipes to avoid any condensation. Use pipe insulators resistant to temperatures over 90°C. In addition if the humidity level in areas where the refrigeration pipes are installed is expected to exceed 70%, protect the pipes with pipe insulators. Use an insulating material thicker than 15mm if the humidity level is 70~80%, and an insulating material thicker than 20mm if the humidity exceeds 80%. If the recommended thicknesses are not observed under the conditions described above, condensation will form on the surface of the insulation material. Lastly, take care to use pipe insulators whose thermal conductivity is 0.045 W/mK or less when the temperature is 20°C. The insulation must be impermeable to resist the passage of steam during the defrosting cycles (fibreglass wool is prohibited).

2.6.2 Refrigeration connections

The outdoor unit must be connected to the hydraulic unit with copper pipes and connections (refrigeration quality), insulated separately.

Comply with the pipe diameters and the permitted pipe lengths ([figure 15, page 18](#)).

The minimum length of the refrigeration connections is 5 m for correct operation.

The appliance will be excluded from guarantee if it is used with refrigeration connections less than 5 m long.

Manipulate the pipes and take them through walls with protective plugs in place.

2.6.3 Accessing the hydraulic module's refrigerant connections

- Remove the front panel (2 screws **A**).
- Remove the left-hand panel (2 screws **B**).

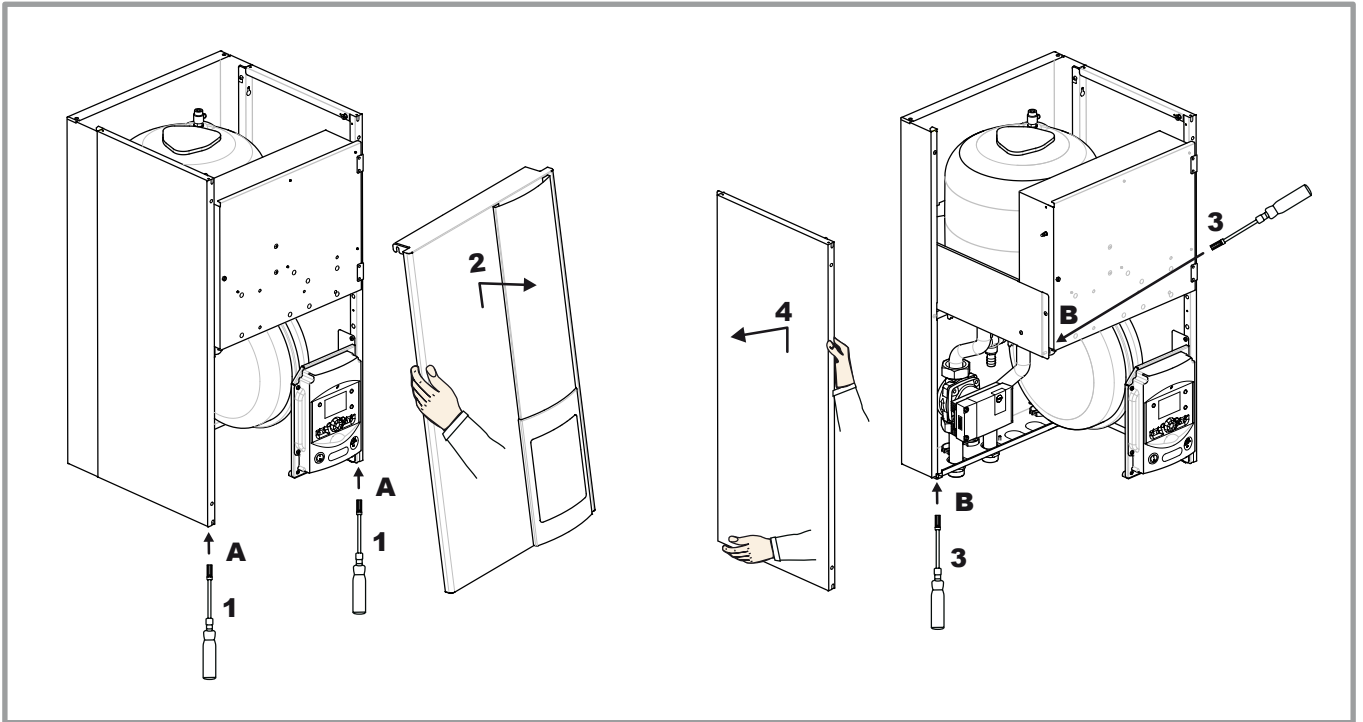

figure 14 - Removing the casing

2.6.4 Creating the flarings

- Cut the pipe to an appropriate length with a pipe-cutter without deforming it.
- Carefully deburr it, holding the pipe towards the bottom to avoid introducing filings into the pipe.
- Remove the flared connection nut situated on the valve to be connected and slip the pipe into the nut.
- Proceed to flare, letting the pipe overflow the flaring tool.
- After flaring, check the condition of the working radius (L). This must not show any scratch or trace of any fracturing. Also check the dimension (B).

2.6.5 Shaping the refrigeration pipes

The refrigeration pipes must be shaped only on a bending machine or with a bending spring in order to avoid any risk of crushing or breaking them.

Warning !

- Remove the insulation material locally to bend the pipes.
- Do not bend the copper to any angle over 90°.
- Never bend pipes more than 3 times in the same position otherwise traces of fracturing may appear (from strain-hardening the metal).

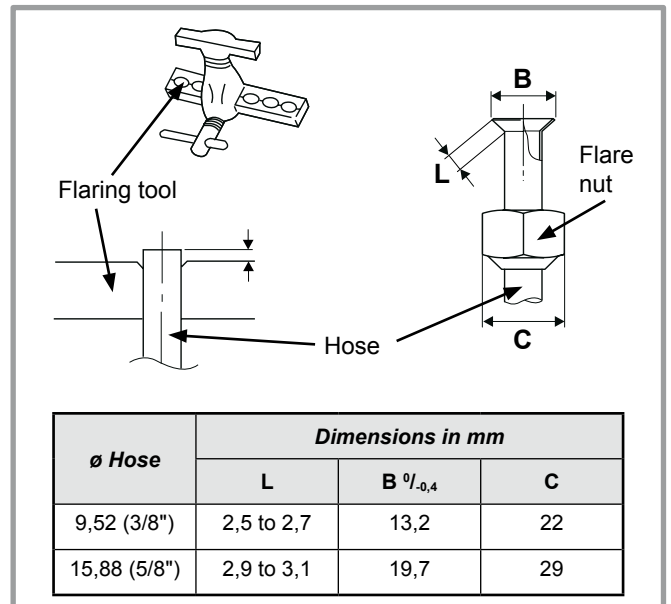

HP model	Waterstage High Power single phase & 3-phase	
	gas	fluid
Outdoor unit connections	5/8"	3/8"
Diameter	(D1) 5/8"	(D2) 3/8"
Refrigeration connections	Minimum length (L)	5
	Maximum length* (L)	15
	Maximum length** (L)	20
	Maxi level difference** (D)	15
Hydraulic unit connections	5/8"	3/8"

* : without additional charge of R410A.

** : Taking into account the possible additional load of refrigerant R410A (see para. "Additional charge", page 20).

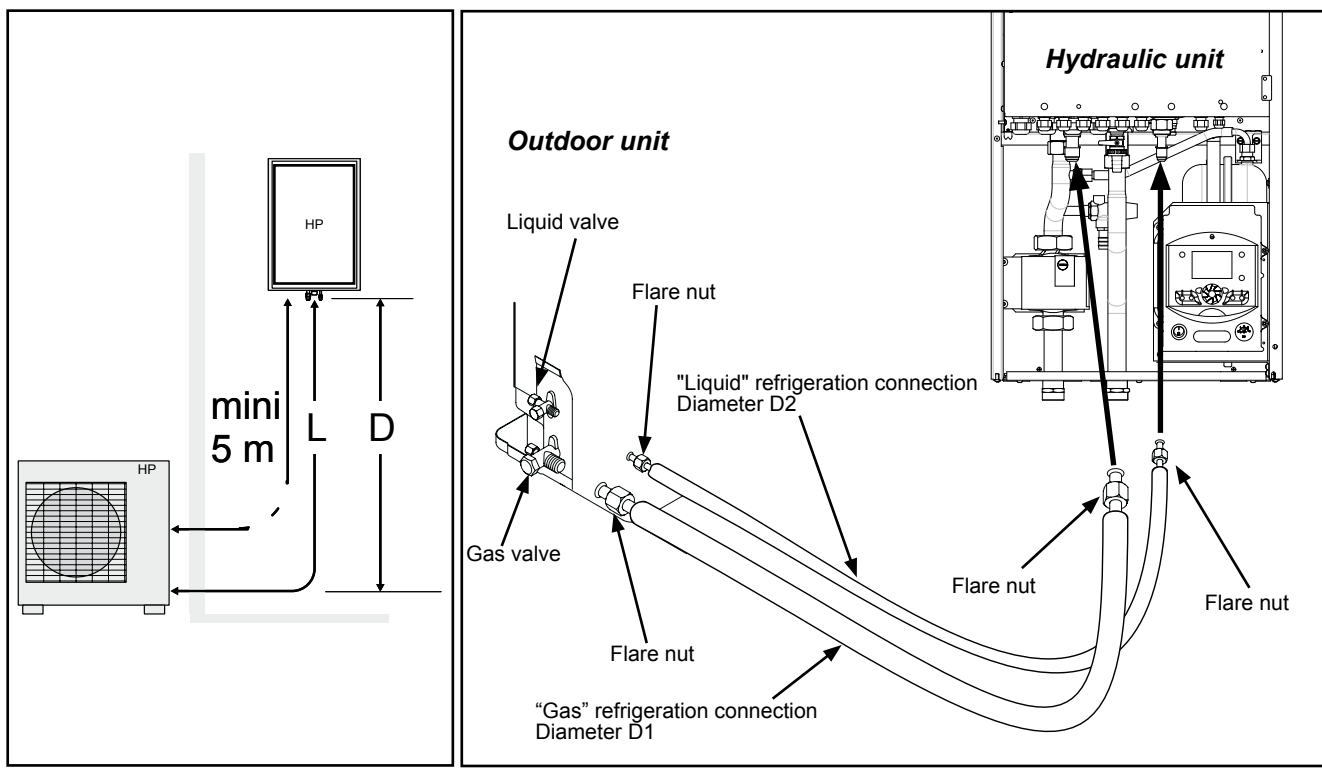

figure 15 - Connecting the flared connections (Pipe diameters and permissible lengths)

2.6.6 Connecting the flared connections

- ☞ The small pipe must always be connected before the large one.
 - ☞ Take particular care positioning the tube opposite its connector so as not to risk damaging the threads. A carefully aligned connector can be fitted easily by hand without much force being required.
 - ☞ The refrigeration circuit is very sensitive to dust and humidity, check that the area around the connection is clean and dry before removing the plugs protecting the refrigeration connectors.
- Remove the plugs from the pipes and the refrigeration connections.
 - Present the pipe to the flared connector and screw the nut by hand while holding the connector with a wrench until contact.
 - **Warning !** Avoid positioning the Gas pipe in front of the pump.
 - Comply with the indicated tightening torques.

Designation	Tightening torque
Flare nut 9,52 mm (3/8")	32 to 42 Nm
Flare nut 15,88 mm (5/8")	63 to 77 Nm
Plug (A) 3/8"	20 to 25 Nm
Plug (A) 5/8"	30 to 35 Nm
Plug (B) 3/8", 5/8"	10 to 12 Nm

figure 16 - Tightening torque

2.7 Filling the installation with gas

- ☞ This operation is reserved for installers familiar with the legislation for handling refrigerants.
- ☞ Creating a vacuum with a vacuum pump is essential.
- ☞ Never use equipment used beforehand with any refrigerant other than a HFC.

2.7.1 Example of commissioning procedure

• First seal test

- Remove the protective plugs (B) from the charging hole (Schrader) in the gas valve (large diameter).
- Connect the hose to the manifold.
- Connect the bottle of nitrogen to the manifold.
- Pressurize the refrigerant circuit to 10 bar with nitrogen.
- Leave the circuit under pressure for half a day.
- Check that the pressure has not fallen.
- Look for and repair any leaks, and then recommence the test.
- Once the pressure has remained steady for a few hours, empty the nitrogen.

• Creating a vacuum and filling the refrigeration connections with gas

- Connect the vacuum pump to the manifold.
- Create a vacuum until the residual pressure in the circuit falls below 0,01 bar.
- Let the pump continue to operate for another 30 minutes after reaching the vacuum.
- Close the blue valve on the set of manometers and then stop the vacuum pump **without disconnecting any of the hoses in place**.
- Leave for at least half a day.

If after this time the pressure has risen, there is a leak. Find and repair the leak and then recommence vacuum testing.

When the pressure remains steady for a few hours after stopping the vacuum pump, the circuit can be considered airtight.

- Remove the access plugs (A) from the valve controls.
- First of all fully open the small valve and then the large one using a hex key (counterclockwise direction) without forcing excessively against the stop.
- Remove the blue hose rapidly.
- Refit the 2 plugs and tighten them to the recommended tightening torque (figure 16, page 18).

The outdoor unit does not contain any additional refrigerant, enabling the installation to be purged.

Flushing is strictly forbidden.

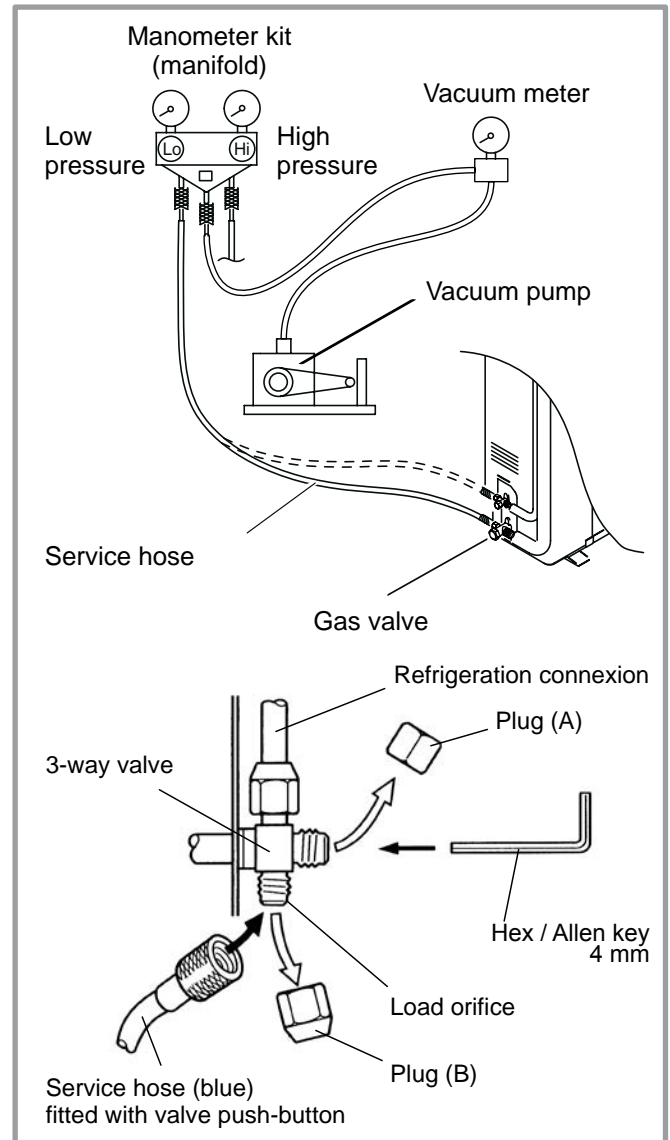

figure 17 - Extraction under vacuum and gassing

2.7.2 Sealing test

Once the refrigeration circuit has been gassed as described above, check that all the refrigeration connectors are gas-tight (4 connectors).

The sealing test must be performed with an approved gas detector. If the flarings have been made correctly, there should be no leaks.

☞ If there is a leak:

- Bring the gas into the outdoor unit (pump down).
- Make the connection again.
- Repeat the commissioning procedure.

2.7.3 Additional charge

	50 g of R410A per additional meter	
Length of the connections	15 m	20 m max.
Additional charge	none	250 g

The charge in the outdoor units corresponds to the maximum distances between the outdoor unit and the hydraulic unit defined in figure 15. If the distances are greater, an additional charge of R410A is required. The additional charge depends on the distance between the outdoor unit and the hydraulic unit for each type of appliance. The additional charge of R410A must necessarily be made by an approved refrigeration engineer.

• Example of additional charge :

An outdoor unit 17 m away from the hydraulic unit will require an additional charge of :

Additional charge = (17 - 15) x 50 = 100 g.

The charge must be introduced after creating the vacuum and before the hydraulic unit is filled with gas, as follows :

- Disconnect the vacuum pump (yellow hose) and connect a bottle of R410A instead in the liquid extraction position.
- Open the bottle's valve.
- Bleed the yellow hose by loosening it slightly on the manifold side.
- Place the bottle on scales with a minimum accuracy of 10 g. Note the weight.
- Carefully open the blue valve slightly and check the value shown on the scales.
- As soon as the value displayed has dropped by the value for the calculated additional charge, close the bottle and disconnect it.
- Then rapidly disconnect the hose connected to the appliance.
- Proceed to fill the hydraulic unit with gas.

⚠ Warning

- Only use R410A !
- Only use tools suitable for R410A (set of manometers).
- Always charge in the liquid phase.
- Never exceed the length or the maximum difference in level.

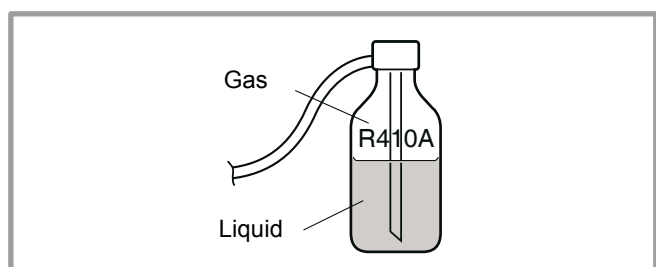

figure 18 - Gas bottle R410A

2.7.4 Pump down operation (Refrigerant collecting operation) single phase outdoor unit

• Preparation for pump down

Confirm that the power (ref. 3, figure 7, page 10) is off, and then open the service panel.

• Pump down procedure

- 1- Check the 3-way valves (both at the liquid side and gas side) are opened.
- 2- Turn the power on.

POWER	ERROR	PUMP DOWN (L1)	LOW NOISE		PEAK CUT		
MODE			(L2)	(L3)	(L4)	(L5)	(L6)
●	○	○	○	○	○	○	○

- 3- Press "PUMP DOWN" switch for 3 seconds or more after 3 minutes after power on.

POWER	ERROR	PUMP DOWN (L1)	LOW NOISE		PEAK CUT		
MODE			(L2)	(L3)	(L4)	(L5)	(L6)
●	○	●	○	○	●	●	●

LED display lights on as shown in the above figure, and the fans and the compressor start operating. If the "PUMP DOWN" switch is pressed while the compressor is operating, the compressor will stop, then start again in about 3 minutes.

- 4- LED display will change as shown below about 3 minutes after the compressor starts. Fully close the 3-way valve on the liquid pipe side at this stage.

POWER	ERROR	PUMP DOWN (L1)	LOW NOISE		PEAK CUT		
MODE			(L2)	(L3)	(L4)	(L5)	(L6)
●	○	●	○	○	○	●	●

If the valve on the liquid pipe side is not closed, the pump down cannot be performed.

- 5- When LED display changes as shown in the below figure, close the 3-way valve on the gas pipe side tightly.

POWER	ERROR	PUMP DOWN (L1)	LOW NOISE		PEAK CUT		
MODE			(L2)	(L3)	(L4)	(L5)	(L6)
●	○	●	○	○	○	○	●

- If the valve on the gas pipe side is not closed, refrigerant may flow into the piping after the compressor stops.

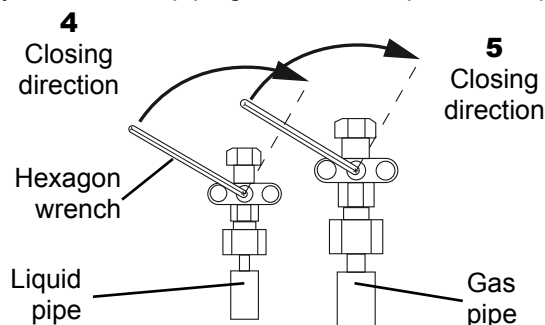

- **6-** LED display changes after 1 minute as shown in the figure below:

POWER	ERROR	PUMP DOWN (L1)	LOW NOISE		PEAK CUT		
MODE			(L2)	(L3)	(L4)	(L5)	(L6)
●	○	●	○	○	○	○	○

Fans and compressor stop automatically. If the pump down is successfully completed (the above LED display is shown), the outdoor unit remains stopped until the power is turned off.

- **7-** Turn the power off.

POWER	ERROR	PUMP DOWN (L1)	LOW NOISE		PEAK CUT		
MODE			(L2)	(L3)	(L4)	(L5)	(L6)
○	○	○	○	○	○	○	○

Note :

- To stop pump down, press the "PUMP DOWN" switch again.
- To start the pump down again after the compressor is automatically stopped due to an error, turn the power off and open the 3-way valves. Wait 3 minutes, turn the power on and start the pump down again.
- When starting the operation after completion of the pump down, turn the power off, and then open the 3-way valves.

2.7.5 Pump down operation (Refrigerant collecting operation) 3-phase outdoor unit

Perform the following procedures to collect the refrigerant.

- **1-** Turn OFF the start/stop switch (ref. 3, figure 7, page 10).
- **2-** Remove the front panel. Then turn ON the DIP SW 1 on the interface card.
- **3-** Turn ON the start/stop switch. (Green and Red LED on the board start flashing ; 1 sec. on / 1 sec. off repeated).
- **4-** The outdoor unit begins cooling operation about 3 minutes after switching ON. Close the liquid valve on the outdoor unit 1 minute after operation starts.
- **5-** Close the gas valve on the outdoor unit 1-2 minutes after closing the liquid valve, while the outdoor unit keeps running.
- **6-** Disconnect the power supply.

Remarks :

- Make sure to turn OFF the start/stop switch before touching DIP SW.
- The pump down operation cannot be activated even if DIP SW is changed while heat pump's power is on.
- Do not forget to turn back DIP SW 1 on the interface card to OFF, after the pump down operation has been completed.
- When the pump down operation is repeated, temporarily turn OFF the start/stop switch after opening the closed valves (both liquid and gas).
- Then turn ON the start/stop switch again after 2 - 3 minutes and perform the pump down operation.

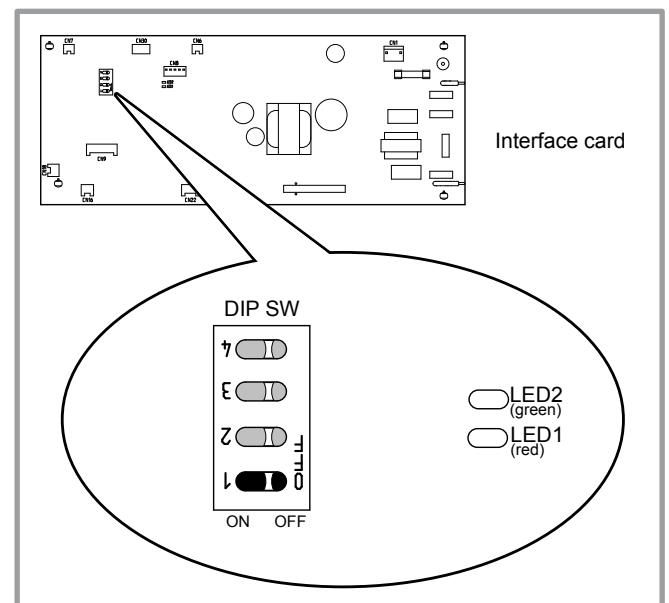

figure 19 - Location of DIP switches and diodes on the hydraulic unit interface card

2.8 Hydraulic connecting

2.8.1 General

The connection must comply with good trade practice according to local building regulations.

The heating circulating pump is built into the hydraulic unit.

Connect the central heating pipes to the appliance, complying with the direction of circulation.

The pipe between the heat pump and the heat collector must be at least one inch in diameter (26x34 mm).

Calculate the diameter of the pipes according to the flow rates and the lengths of the hydraulic systems.

Tightening torque: 15 to 35 Nm.

Use union connectors to facilitate removing the hydraulic unit.

Preferentially use connection hoses to avoid transmitting noise and vibrations to the building.

Connect the drains from the drain valve and the safety valve to the main sewer system.

Verify the correct functioning of the expansion system. Control the vessel pressure (1 bar) and the safety valve setting.

Reminder: Seal everything when fitting in accordance with prevailing trade practice for plumbing work:

- Use suitable seals (fibre seals, o-rings).
- Use Teflon tape or hemp.
- Use sealing paste (synthetic depending on the case).

The use of glycol is not necessary. If you are using a glycol/water mix, provide for an annual check on the quantity of glycol. Use monopropylene glycol only. **Never use monoethylene glycol.**

- ☞ **In certain installations, the presence of different metals can cause corrosion problems; the formation of metal particles and sludge in the hydraulic circuit is then seen.**
- ☞ **In this case, it is advisable to use a corrosion inhibitor in the proportions indicated by its manufacturer.**
- Please refer to the chapter "Treatment of domestic and heating water" in our price catalogue.
- ☞ **It is also necessary to ensure that the treated water does not become aggressive.**

2.8.2 Rinsing out the installation

Before connecting the hydraulic unit to the installation, rinse out the heating system correctly to eliminate any particles that may affect the appliance's correct operation.

Do not use solvents or aromatic hydrocarbons (petrol, paraffin, etc.).

In the case of an old installation, provide a sufficiently large decanting pot with a drain on the return from the boiler and at the lowest point in the system in order to collect and remove the impurities.

Add an alkaline product to the water and a dispersant.

Rinse the installation several times before filling it definitively.

2.8.3 Filling and purging the installation

Check the pipe fixings, the tightness of the connectors and the stability of the appliance.

Check the direction in which the water is circulating and that all the valves open.

Proceed to fill the installation.

Do not operate the circulating pump while filling. Open all the drain valves in the installation and the bleeder valve for the hydraulic unit (**P**) to remove the air contained in the conduits.

Close the drain and bleeder valves and add water until the pressure in the hydraulic circuit reaches 1 bars.

Check that the hydraulic circuit has been purged correctly.

Check there is not a leak.

After the "Start-up" stage (see [page 31](#)), once the machine has started, purge the hydraulic unit again (2 litres of water).

- ☞ **Precise filling pressure is determined by the manometric height of the installation.**

2.8.4 Connecting the Fan convector circuit

Heat pump > 11 kW: It must be installed on this circuit a buffer tank (minimum capacity: 50 liters).

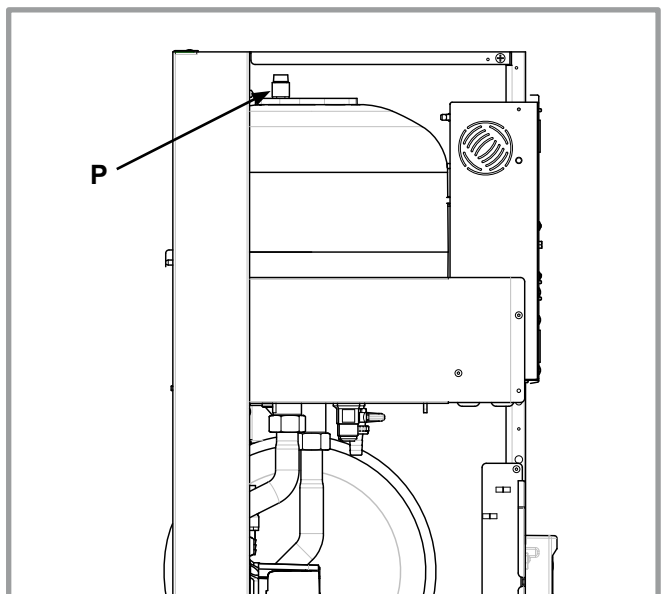

figure 20 - Hydraulic module bleeder valve

2.9 Heating circulation pump speed settings

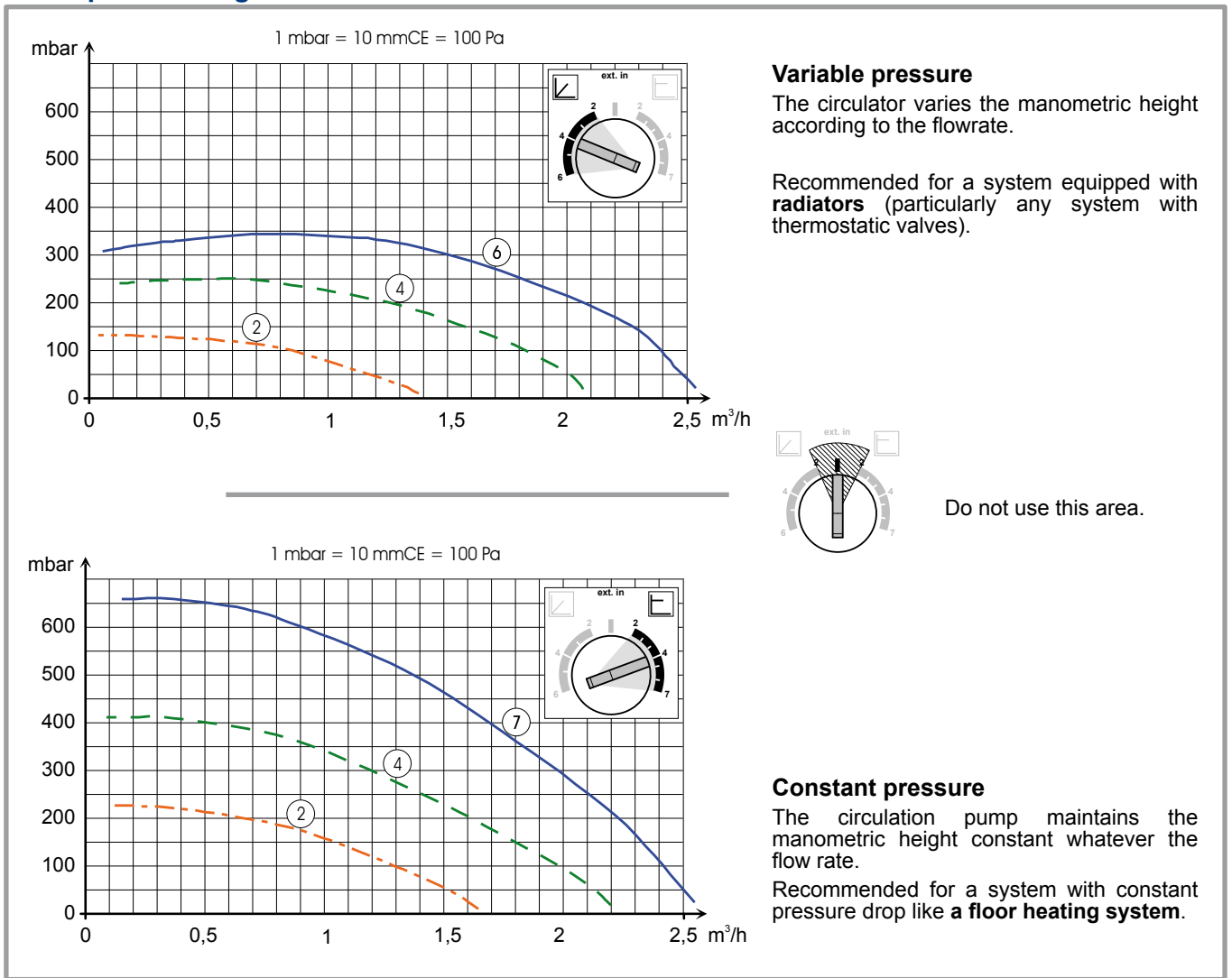

figure 22 - Hydraulic pressures and flow rates available

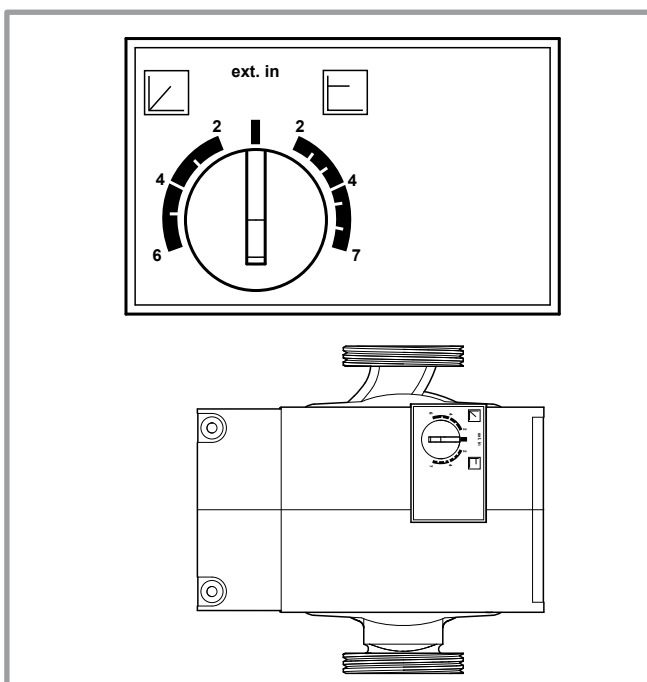

figure 21 - Pump dial

Circulation pump sticking or blocked:

If the motor is blocked, a start cycle is launched.

If the motor remains blocked it will be permanently stopped.

- ☞ **Cut off the electricity supply from the circulation pump for 30 seconds in order to release and authorise another start cycle.**

2.10 Electrical connections

Ensure that the general electrical power supply has been cut off before starting any repair work.

2.10.1 Characteristic of the electrical supply

The electrical installation must be conducted in accordance with the prevailing regulations.

The electrical connections must only be made when all the other fitting operations have been completed (fixing, assembly, etc.).

⚠ Warning !

The contract concluded with the energy provider must be sufficient not only to cover the heat pump's power but also the combined sum of all the appliances likely to be operating at the same time. When the power is too low, check with your energy provider the value subscribed to in your contract.

Never use a socket for the power supply.

The heat pump must be supplied with power by special protected leads from the electric panel via 2-pole circuit breakers specially dedicated to the heat pump, Curve D for the outdoor unit, curve C for the electrical heating and domestic water back-ups (see tables on [page 25](#)).

The electrical installation must necessarily be equipped with a 30mA differential protection.

This appliance is designed to operate under a nominal voltage of 230 V or 400 V, +/- 10%, 50 Hz (according to model).

2.10.2 General remarks on electrical connections

It is essential to maintain the live-neutral polarity when making the electrical connections.

Tighten the screws on the terminal blocks perfectly. Unsufficient tightening can cause overheating, leading to breakdown or even a fire.

Tighten the cables using the cable glands to prevent the conductors from disconnecting accidentally.

Connection to Earth and Earth bonding continuity are essential.

• Connecting to screw terminals

Rigid wires (A)

Rigid wires are always preferable for fixed installations, particularly in a building.

- Always select a wire that complies with the prevailing standards.
- Strip away around 25 mm from the end of the wire.
- With round end pliers, form a loop with a diameter corresponding to the tightening screws on the terminal.
- Tighten the terminal screw firmly onto the loop created.

Flexible wires (B)

H07RNF type (or superior quality) flexible wire can be used with certain precautions:

- Strip away around 10 mm from the end of the wire.
- With tightening pliers, fit a round tag with a diameter corresponding to the terminal screw's diameter on the end of the wire.
- Tighten the tag firmly onto the terminal with a screwdriver. We strongly advise against using flexible wires without round tags.
- Always protect the cables when passing them through cable clamps with PVC protective conduit 0,5 to 1 mm thick.

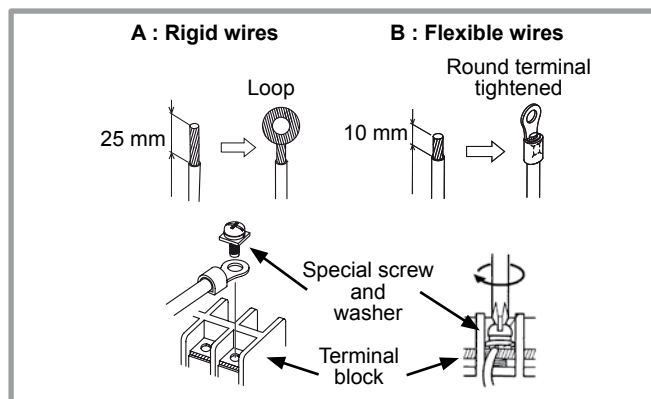

• Connecting to regulation cards

- Remove the corresponding connector and make the connection.

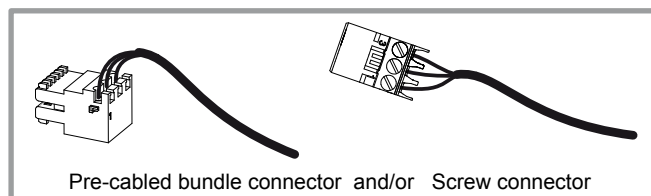

• Connecting to spring terminals

Rigid wires

- Strip away around 10 mm from the end of the wire.
- Slide the wire into the opening provided for this purpose.
- Push the spring with a screwdriver so that the wire enters the cage.
- Remove the screwdriver and then check that the wire is jammed in the cage by pulling on it.

Flexible wires

- Use the ends and proceed as before.

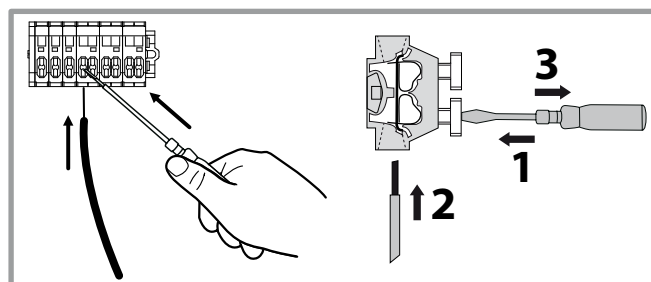

2.10.3 Overview of all the electrical connections

The wiring diagram for the hydraulic unit is shown in detail on figure 42, page 54.

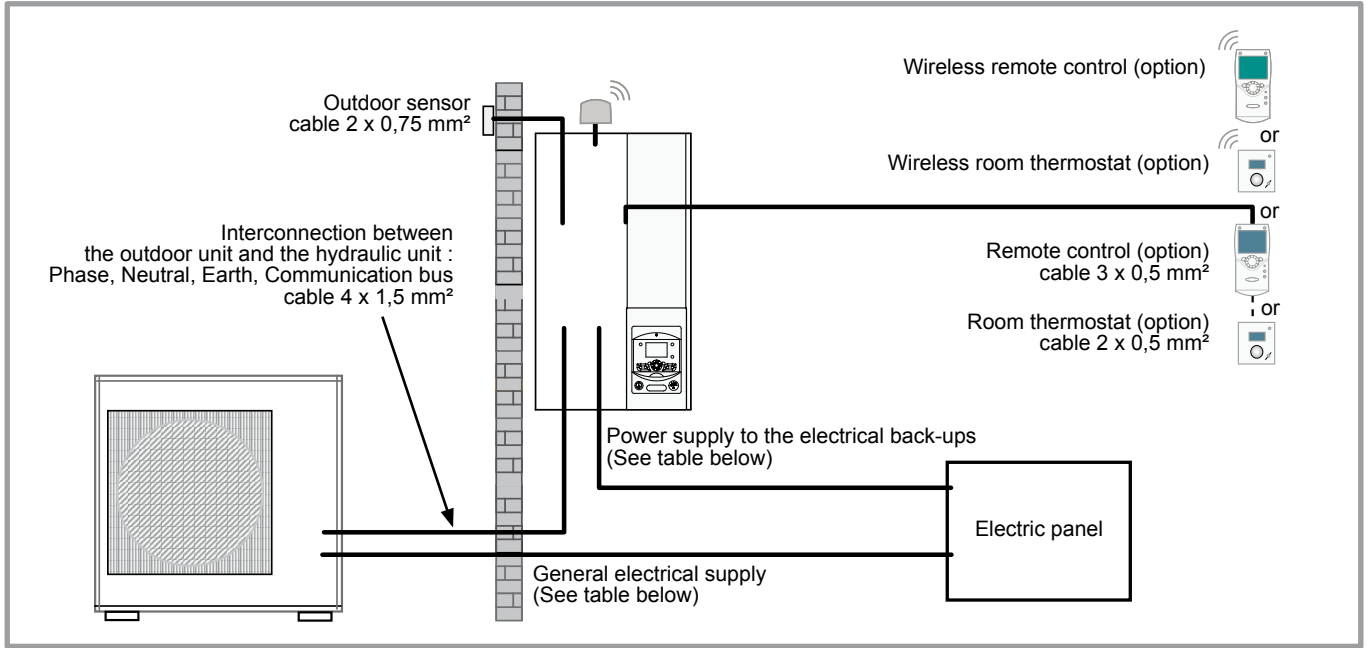

figure 23 - Overall layout of the electrical connections for a simple installation (1 heating circuit)

2.10.4 Cable section and protection rating

The cable sections are given for information purposes only and do not exempt the installer from checking that these sections correspond to the requirements and comply with the prevailing standards.

• Power supply to outdoor unit

<i>Heat pump (single phase)</i>		<i>Electricity supply 230 V - 50 Hz</i>	
<i>Model</i>	<i>Maxi. power absorbed</i>	<i>Cable connection (phase, neutral, earth)</i>	<i>Curve D circuit breaker size</i>
High Power 11 single phase	5060 W	3 x 6 mm ²	32 A
High Power 14 single phase	5750 W		
<i>Heat pump (3-phase)</i>		<i>Electricity supply 400 V - 50 Hz</i>	
<i>Model</i>	<i>Maxi. power absorbed</i>	<i>Cable connection (3 phases, neutral, earth)</i>	<i>Curve D circuit breaker size</i>
High Power 11 3-phase	5865 W	5 x 2,5 mm ²	20 A
High Power 14 3-phase	6555 W		
High Power 16 3-phase	7245 W		

• Interconnection between the outdoor unit and the hydraulic unit

The hydraulic unit is powered by the outdoor unit by means of a cable with 4 x 1,5 mm² (phase, neutral, earth, communication bus).

• Power supply to the electrical back-ups

The hydraulic unit contains two stages of electrical back-ups installed in a heat exchange tank.

<i>Heat pump (HP)</i>	<i>Electrical back-ups</i>		<i>Power supply to the electrical back-ups</i>	
<i>Model</i>	<i>Power</i>	<i>Nominal current</i>	<i>Cable connection</i>	<i>Curve C circuit breaker size</i>
High Power single phase	2 x 3 kW	26,1 A	3 x 6 mm ²	32 A
High Power 3-phase	9 kW	13 A	4 x 2,5 mm ²	20 A

☞ Ensure that the general electrical power supply has been cut off before starting any repair work.

2.10.5 Electrical connections on the single phase outdoor unit side

Access to the connection terminals:

- Remove the front panel. Remove the screws and the front panel.

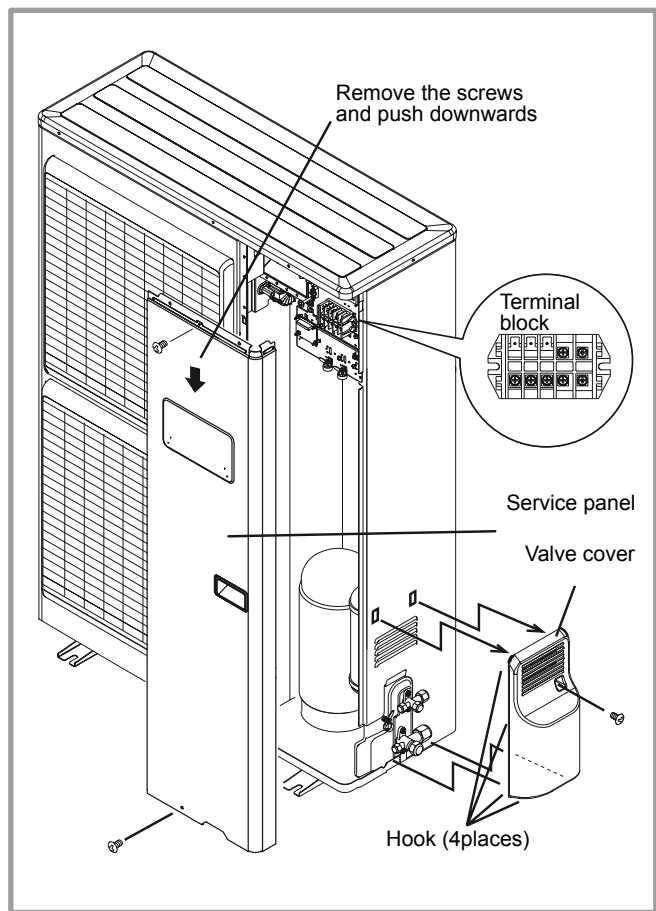

figure 24 - Access to single phase outdoor unit's terminal block

- Make the connections in accordance with the diagram figure 33, page 30.

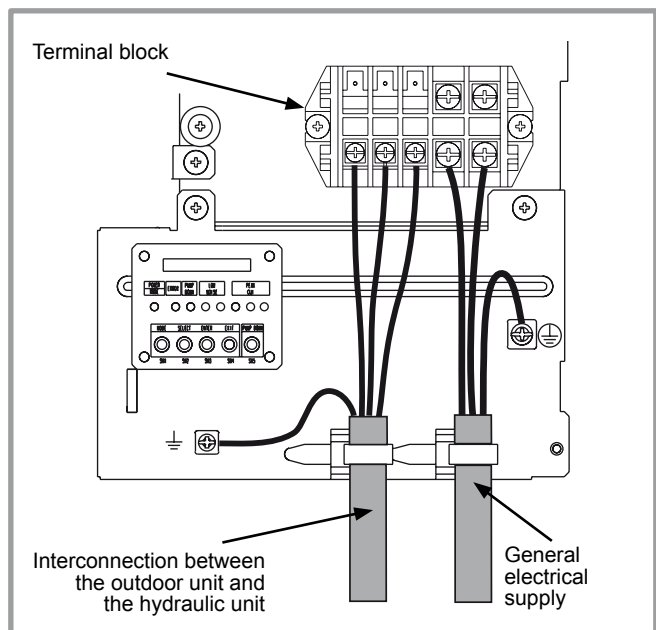

figure 25 - Connections to single phase outdoor unit's terminal block

- Use cable clamps to prevent the conductors from being disconnected accidentally.
- Use the cover plate to hold the cables against the insulating plate.

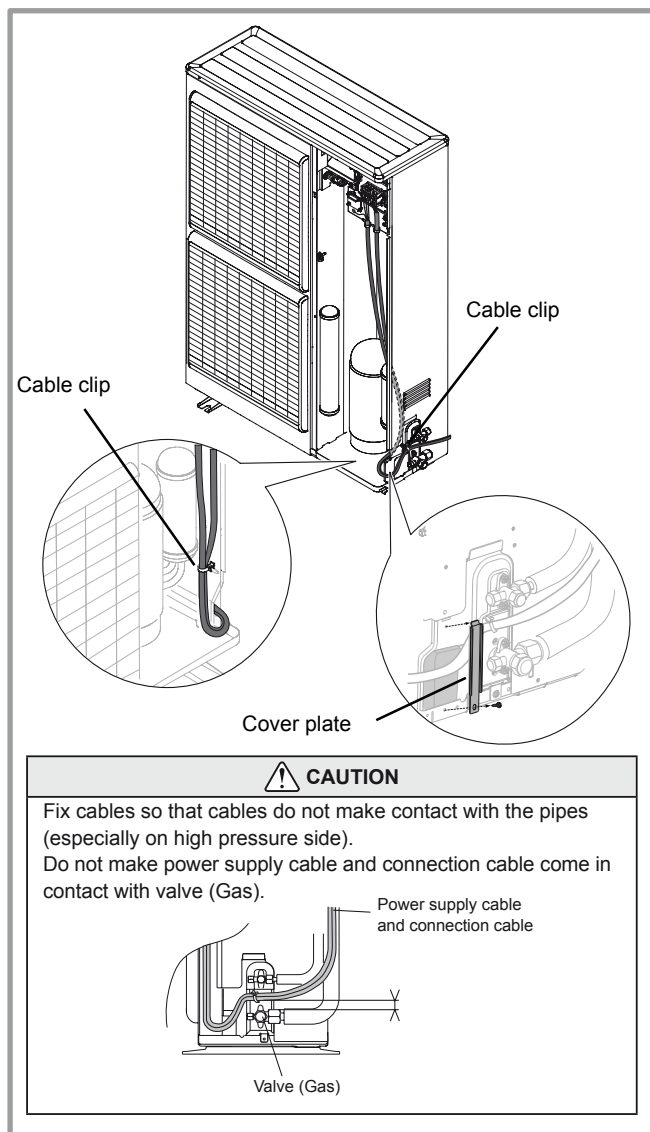

figure 26 - Finalisation of connection to single phase outdoor unit

**2.10.6 Electrical connections
on the 3- phase outdoor unit side**

Access to the connection terminals.

- Remove the front panel. Remove the screws and the front panel.

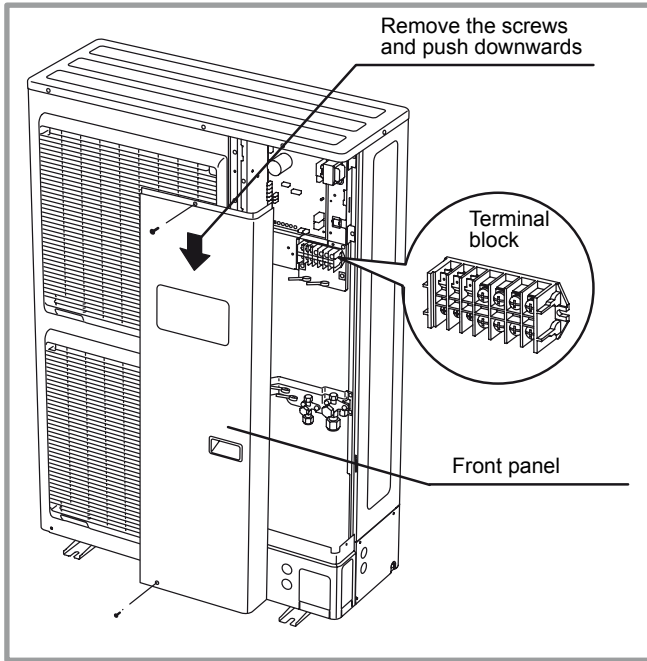

figure 27 - Access to 3-phase outdoor unit's terminal block

- Make the connections in accordance with the diagram figure 33, page 30.

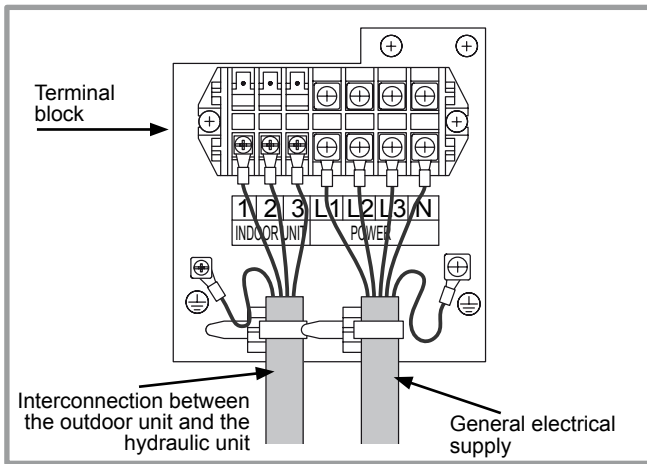

figure 28 - Connections to 3-phase outdoor unit's terminal block

- Use cable clamps to prevent the conductors from being disconnected accidentally.
- Fill in the space where the cables enter the outdoor unit with the insulating plate.

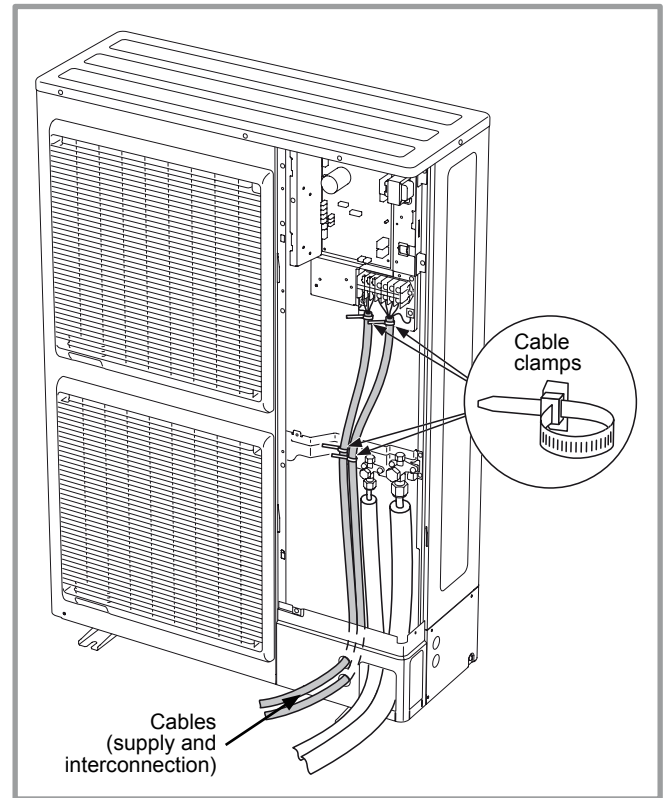

figure 29 - Finalisation of connection to 3-phase outdoor unit

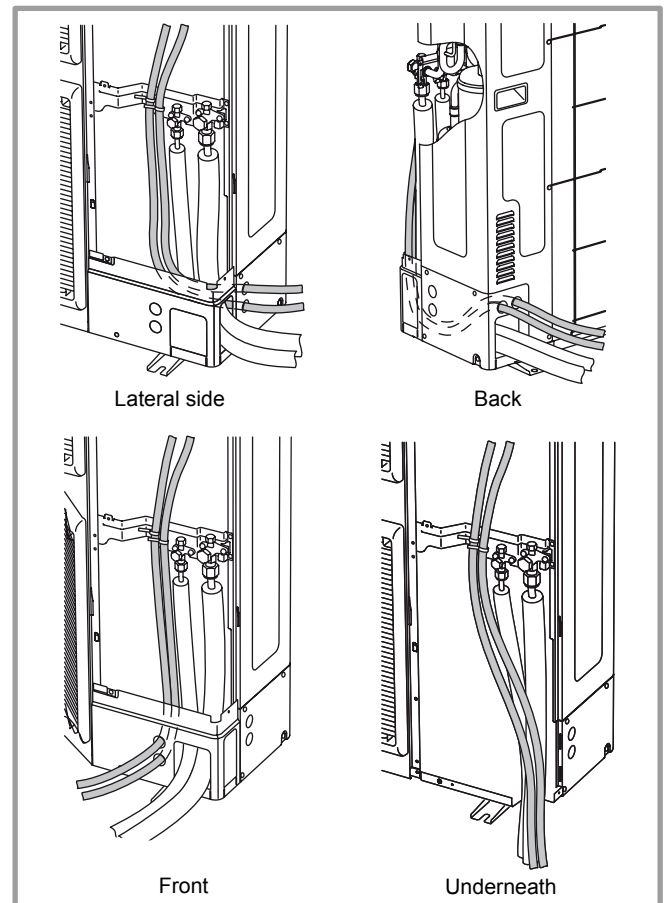

figure 30 - Location of electrical cables and refrigeration connections to 3-phase outdoor unit

2.10.7 Electrical connections on the hydraulic unit side

Access to the connection terminals:

- Remove the front panel (2 screws) (figure 14, page 17).
- Open the power control box.
- Make the connections in accordance with the diagram figure 32.

Do not place the sensor lines and the sector supply lines in parallel in order to avoid interferences due to voltage points in the sector supply.

Ensure that all the electrical cables are housed in the spaces provided for this purpose.

• Interconnection between the outdoor unit and the hydraulic unit

Comply with the correspondence between the markings on the hydraulic unit's terminals and those on the outdoor unit when connecting the interconnection cables.

A connection error could cause the destruction of one or other of the units.

• Boiler connection (option)

- Please refer to the instructions supplied with the boiler connection kit.
- Please refer to the instructions supplied with the boiler.

• Second heating circuit

- Please refer to the instructions supplied with the second circuit kit or/and Regulation extension kit.

• DHW tank with electrical back-up heating (option)

If the installation is fitted with a DHW tank with electrical back-up heating:

- Please refer to the instructions supplied with the DHW kit.
- Please refer to the instructions supplied with the DHW tank.

• Contract with the power provider

The heat pump's operation can be controlled to suit special contracts (e.g. off-peak, day/night). In particular, domestic hot water (DHW) at Nominal temperature will be produced during the off-peak hours when electricity is cheaper.

- Connect the "Power Provider" contact to input EX2.
- Set the parameter (1620) to "Off-peak hours".
- 230V on input EX2 = "Peak hours" information activated.

• Power shedding or EJP (peak day removal)

Power limitation is intended to reduce electrical consumption when this is too high compared to the contract with the power provider.

- Connect the power limiting device to input EX1, the back-ups for the heat pump and the DHW stop in the event of over-consumption by the dwelling.
- 230 V on input EX1 = power limitation in progress.

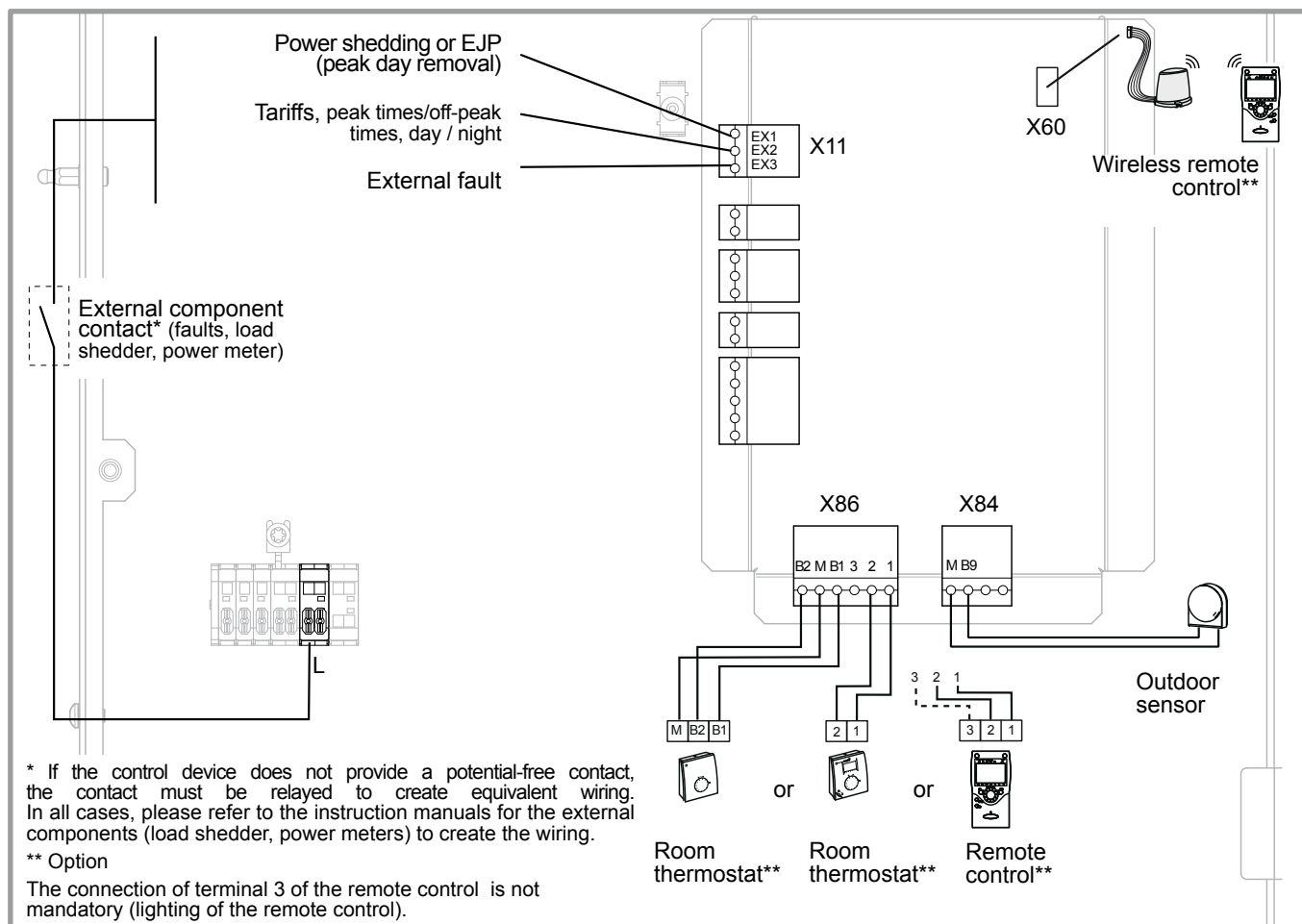

• **External faults the heat pump**

Any component of carryforward of information (thermostat, pressure switch, etc.) may signal an external problem and stop the heat pump.

- Connect the external component to input EX3.

• 230 V on input EX3 = stoppage of heat pump (the system displays Error 369).

- In the case of a heated floor, insert the heated floor thermal safety in the binding of circulating heated floor.

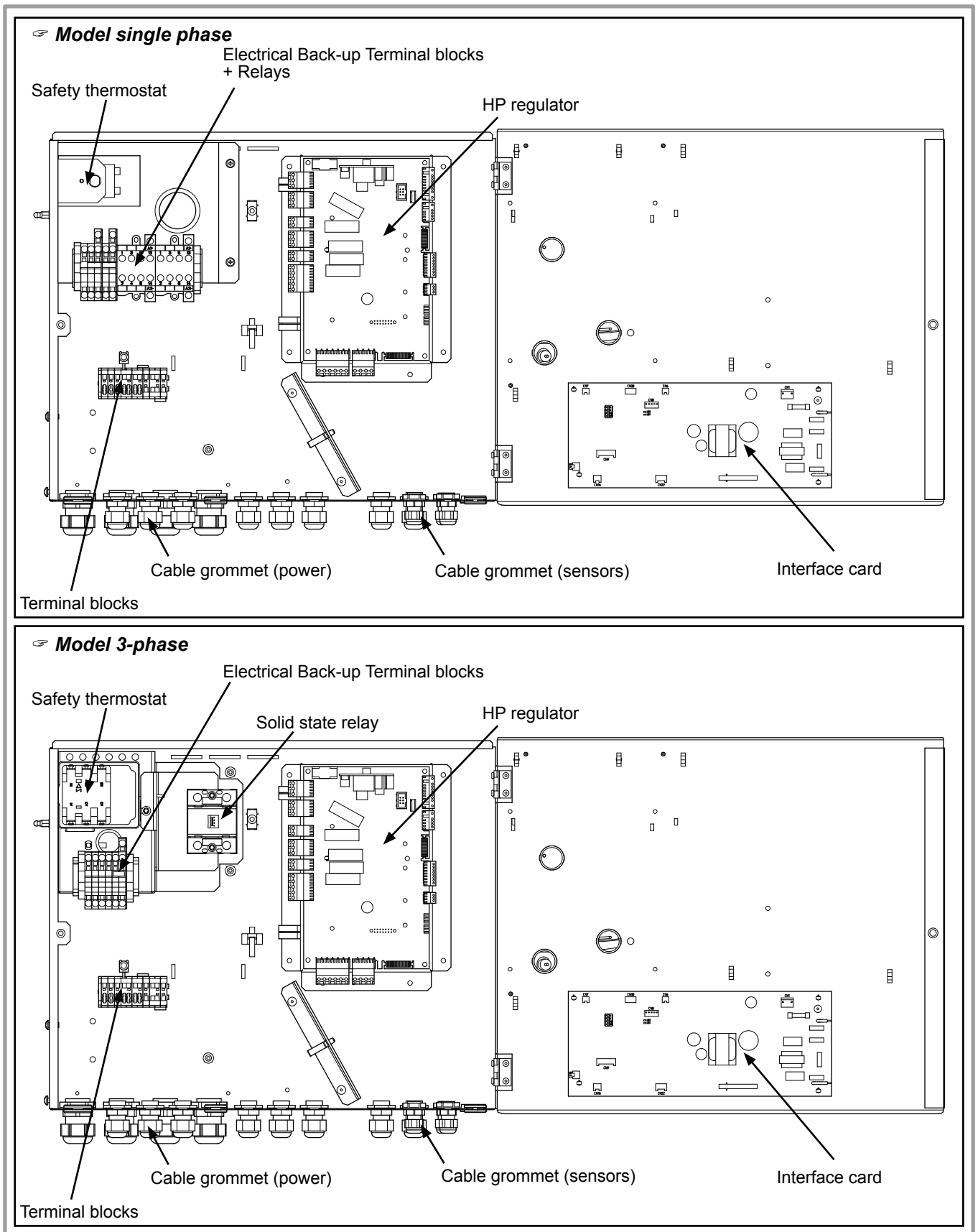

figure 32 - Access to hydraulic model electric box and description

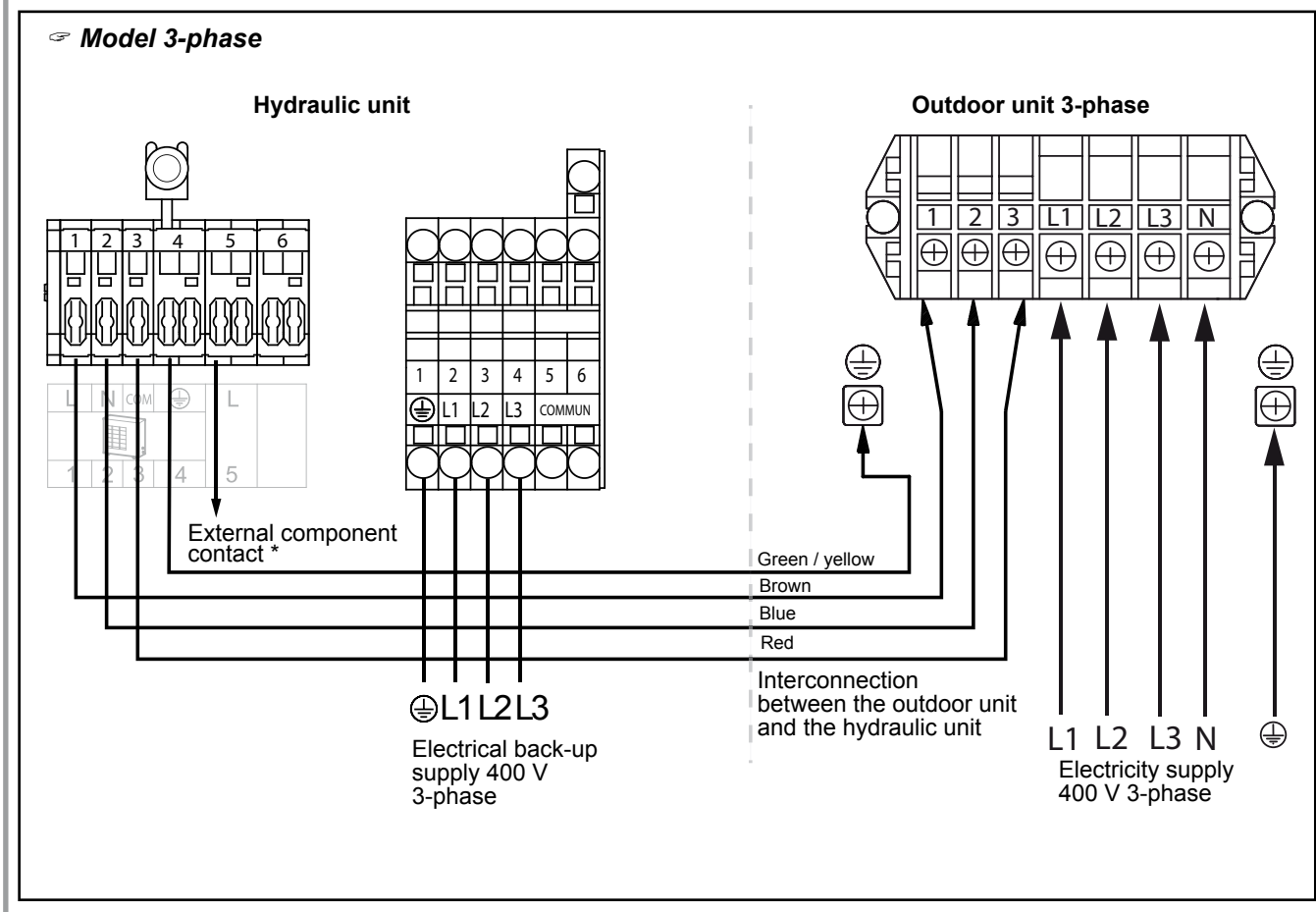
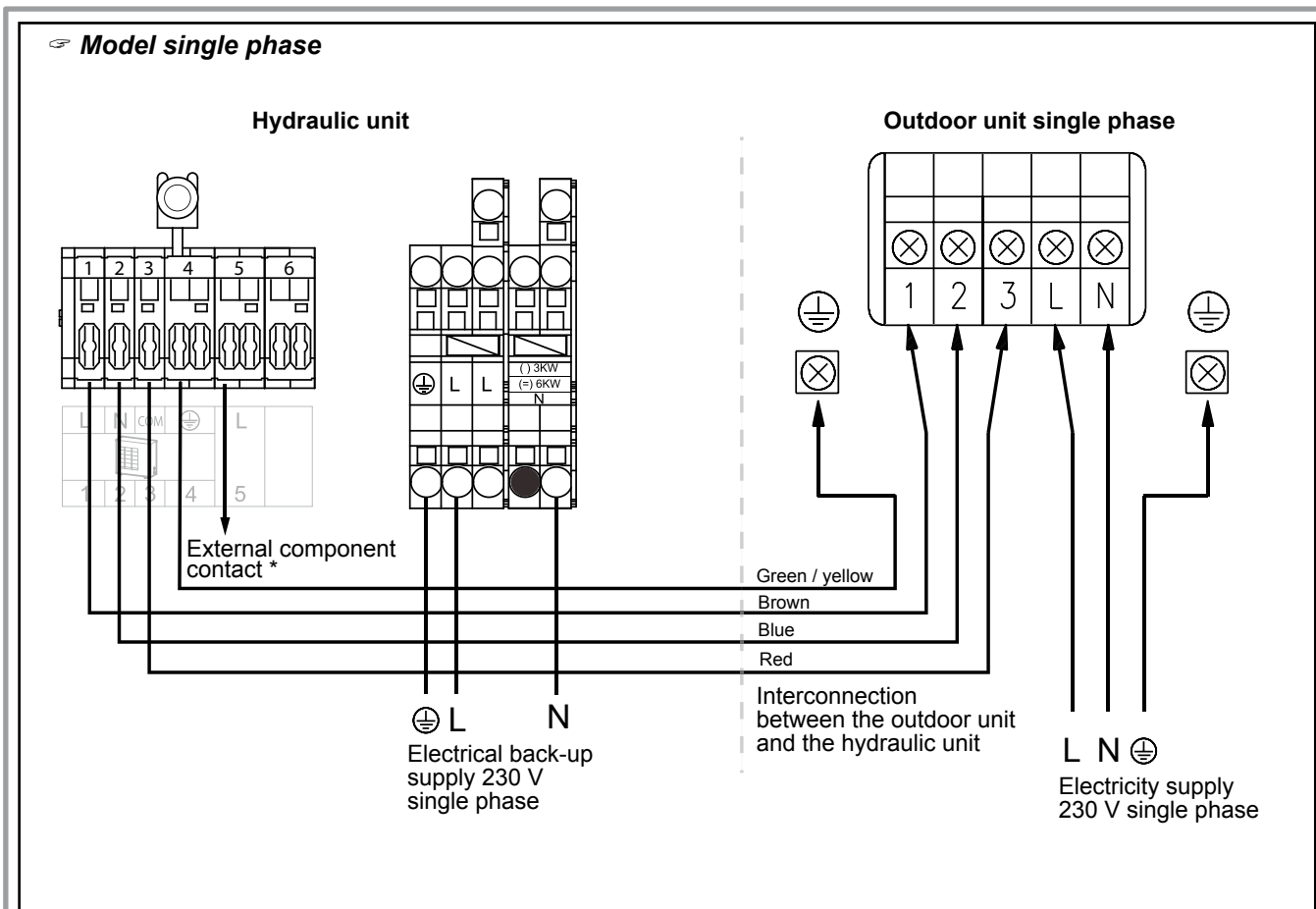

figure 33 - Connection to terminal block and power relays

2.11 Outdoor sensor

The outdoor sensor is required for the heat pump to operate correctly.

Consult the fitting instructions on the packaging.

Place the sensor on the coldest part, generally the northern or north-eastern side.

In any case, it must not be exposed to the morning sun. It must be installed so as to be easily accessible but at least 2,5 m from the floor.

It is essential that it avoid any sources of heat such as flues, the upper parts of doors and windows, proximity to extraction vents, the underneath of balconies and under-eave areas, which would isolate the sensor from variations in the outdoor air temperature.

- Connect the outdoor sensor to the connector **X84** (terminals **M** and **B9**) on the heat pump control board.

2.12 Room thermostat and/or remote control

The room thermostat (remote control) is optional.

Consult the fitting instructions on the packaging.

The sensor must be installed in the living room area on a very uncluttered wall, 1,5 m above the floor.

Avoid direct sources of heat (chimney/flue, television, cooking hobs), draughty areas (ventilation, door, etc.).

Air leaks in the seals in the constructions are often translated into cold air blowing through the electrical conduits. Lag the electrical conduits if there is a cold draught on the back of the IR sensor.

2.12.1 Installing a room sensor

• Room thermostat

- Connect the room thermostat to the **X86** connector of the heat pump's regulator board using the connector provided (terminals **1**, **2**).

• Wireless room thermostat

- Connect the wireless room thermostat to the connector **X60**.

2.12.2 Installing a remote control

• Remote control

- Connect the remote control to the **X86** connector of the heat pump's regulator board using the connector provided (terminals **1**, **2** and **3**).

• Wireless remote control

- Connect the wireless remote control to the connector **X60**.

2.13 Commissioning

- Close the installation's main circuit breaker.

On first commissioning (or in winter), in order to allow the compressor to pre-heat, engage the installation's main circuit breaker (power supply to the outdoor unit) some hours before starting up the tests.

- Engage the start/stop switch.

To ensure that inputs EX1, EX2 and EX3 operate correctly: Check that the live-neutral polarity of the electrical supply is correct.



When the power is switched on and every time that the ON/OFF button is switched off and then switched on again, the outdoor unit will take approximately 4 minutes to start up, even if the setting is requesting heating.

The display can show error 370 when the appliance (re)starts. Do not be concerned, the communication between the outdoor and hydraulic unit will re-establish itself in a few moments.

During the regulator initialisation phase, the display shows all the symbols and then "Data, update" and then "State heat pump"

- Make all the specific adjustments to the setting. (Installation configuration):

- Press .

- Hold down the key  for 3s and select the level of access used with the aid of the knob. .

- Confirm with the key .

- Parameter the heat pump's setting (Consult the settings' list [page 38](#)).

On commissioning (or the case of error 10), the electrical back-up heaters are liable to start up even if the outdoor temperature at the time is above the heaters' trigger temperature.

The regulating system uses an average initial outdoor temperature of 0°C and requires some time to update this temperature.

To avoid this situation, the sensor must be connected correctly. Re-initialise parameter 8703 (commissioning level, consumer diagnostic menu).

2.14 Configuring room thermostat

To configure the room thermostat and connect it to the appropriate heating zone:

- Hold down the presence key for more than 3 seconds. The room thermostat displays RU and a number flashes.
- Turn the wheel to choose the zone (1, 2).
- **If the installation is fitted with 2 room thermostats,**
 - **First connect one room thermostat and configure it in zone 2,**
 - **Then connect the other room thermostat and configure it as default in zone 1.**

- Hold down the presence key; the room thermostat displays P1 and a flashing number.
 - 1: Automatic recording: a correction of the setting with the button is adopted without any particular confirmation (timeout) or by pressing the mode key.
 - 2: Recording with confirmation: a correction of the setting with the button is not adopted until the mode key is pressed.

- Press the presence key again; the room thermostat displays P2 and a flashing number.

0: OFF: all the operating elements are engaged.

1: ON: the following operating elements are locked:

- Switching over the heating circuit's operating mode,
- Adjusting the comfort setting,
- Changing the operating level.

The room thermostat displays OFF for 3 seconds when a locked button is pressed.

2.15 Configuring remote control (wireless)

During commissioning, after an initialisation period of approx. 3 minutes, the user's language must be set:

- Press .
- Choose menu "Operator section".
- Choose language.
- Select the language (**English**, Deutsch, Français, Italiano, Nederlands, Español, Português, Dansk...).

In the case of 2 heating circuits

- Choose the allocation of the remote control (room appliance 1 or 2...) line **40*** (see [page 38](#)).
- According to the allocation selected check and, if necessary, modify the settings for lines **42***, **44***, **48*** (see [page 38](#)).

Line	Function	Setting range or display	Setting increment	Basic setting
40	I Use as...	Room appliance 1, 2, P, User interface 1, 2, P, Service appliance		Room appliance 1
	This line regulates the use of the remote control. (lines 42, 44, 48).		Depending on how it is used, other settings will be necessary	
42	I Appliance allocation 1	Heating circuit 1, Heating circuit 1 & 2, Heating circuit 1 & P, All the heating circuits		Heating circuit 1
44	I Operation HC2 (command HC2)	Commonly with HC1, Independent		Commonly with HC1
	This function enables you to choose whether you wish the room thermostat (as an option) to act on both zones or just a single zone.			
48	I Occupancy control switch function	Without, Heating circuit 1, Heating circuit 2, Common		

* **These parameter lines are only accessible from the remote control.**

3 Regulation system

3.1 User interface, Remote control (option) and Room thermostat (option)

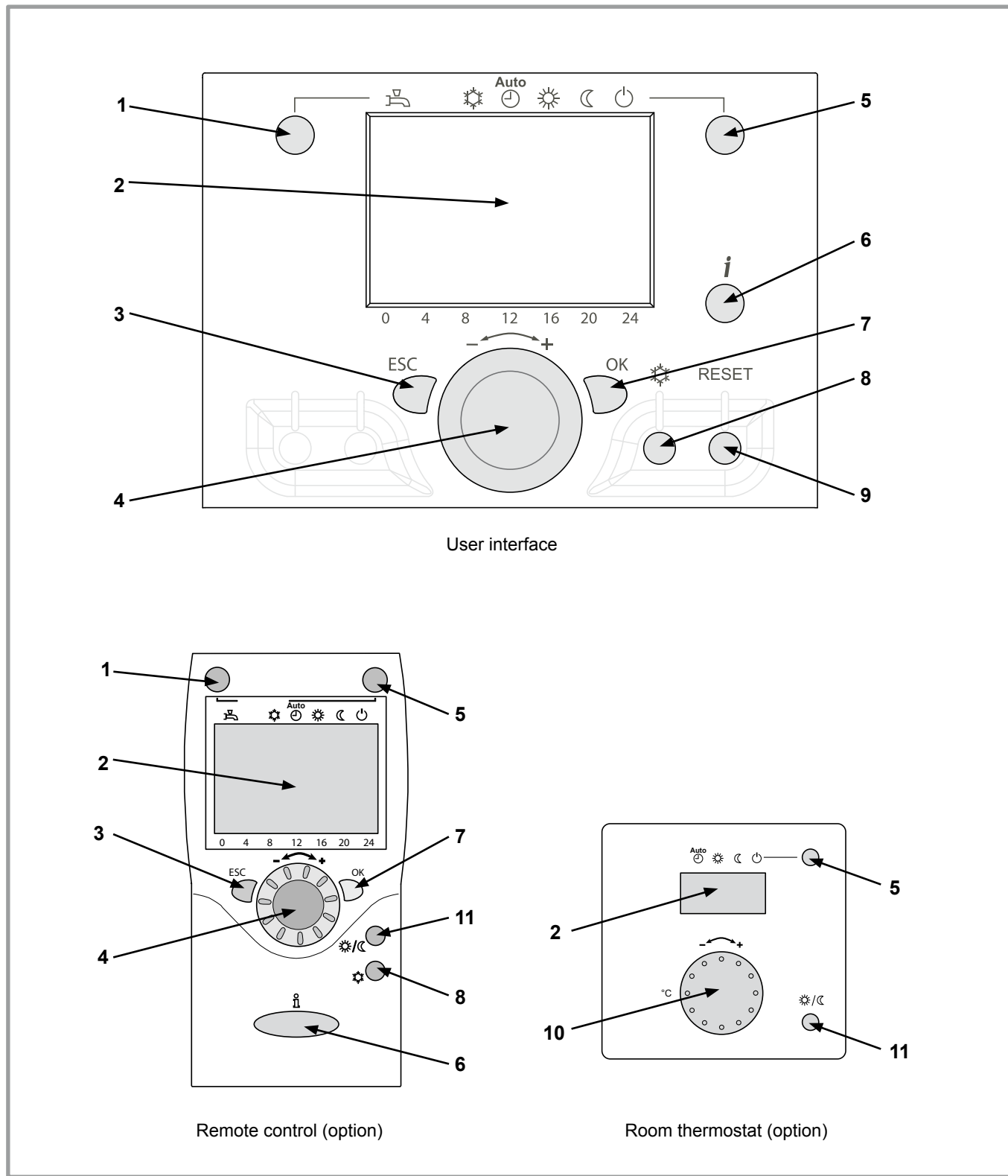













figure 34 -

Ref.	Function	- Definitions
1	Selecting of the DHW operating mode (Domestic hot water)	<ul style="list-style-type: none"> - If the installation is fitted with a DHW tank. - On: Production of DHW according to the time program. - Off: Preparing the domestic hot water for stopping with the anti-frost function active. - Manual start button: Hold down the DHW key for 3 seconds. Switch from "reduced" to "comfort" until the next time the ECS timer switches over.
	 On 	
	 Off	
2	Digital display	<ul style="list-style-type: none"> - Operating control. Readout of the current temperature, of the heating mode and of any faults  . - View the settings.
3	Exit "ESC"	- Quit the menu.
4	Navigation and setting	<ul style="list-style-type: none"> - Selecting the menu. - Setting parameters. - Adjusting the ambient temperature setpoint.
5	Selecting the heating mode	<ul style="list-style-type: none"> -  Heating operating according to the heating program (Summer/winter mode switchover is automatic). -  Constant comfort temperature. -  Constant reduced temperature. -  Stand-by mode with anti-frost protection (Provided that the heat pump's electrical power supply is not interrupted).
6	Information display	<ul style="list-style-type: none"> - Various data (please see page 59). -  Reading error code (please see page 56). -  Information concerning maintenance, special mode.
7	Confirm "OK"	<ul style="list-style-type: none"> - Input into the selected menu. - Confirmation of the parameter settings. - Confirmation of the adjustment to the comfort temp. setting.
8	Selecting cooling mode	<ul style="list-style-type: none"> - If the installation is fitted with the cooling kit: -  Cooling operating according to the heating program (Summer/winter mode switchover is automatic).
9	RESET button (Hold down the "RESET" key for 3 sec).	<ul style="list-style-type: none"> - Reinitialising the parameters and cancelling error messages. <p>Do not use during normal operation.</p>
10	Control knob	- Adjusting the ambient temperature setpoint.
11	Presence key	- Comfort / Reduced switchover.

3.2 Description of the display

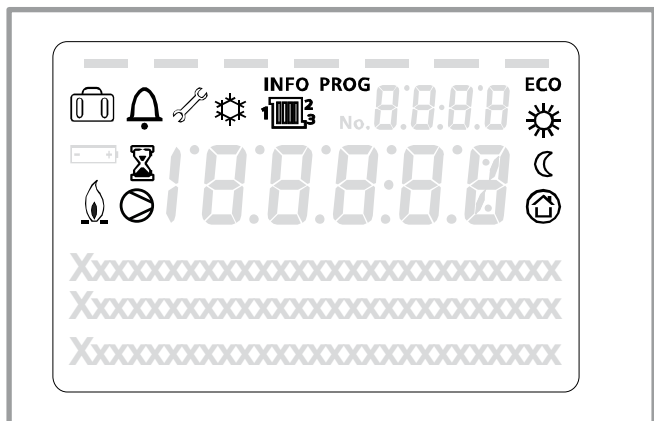

figure 35 - User interface display

Symbols	Definitions
	- Heating mode active with reference to the heating circuit.
	- Heating in comfort mode.
	- Heating in reduced mode.
	- Heating in "standby" mode (freeze protection).
	- Cooling mode active.
	- Holiday mode activated.
	- Process in progress.
	- Compressor operation.
	- Burner operation.
	- Default message.
	- Service / Special operation.
INFO	- Information level activated.
PROG	- Program activated.
ECO	- ECO mode activated (Heating temporarily stopped).
	- Hour / Parameter number / Setpoint value.
	- Room temperature / Setpoint value.
	- Setpoint information / Parameter Information.

3.4 Temperature control

The heat pump's operation is subject to the temperature control.

The set temperature for the water in the heating circuit is adjusted according to the outdoor temperature.

If there are thermostatic valves on the installation, these must be fully open or adjusted for higher than the normal set temperature.

3.4.1 Set to

During installation, the temperature control must be parametered according to the heat emitters and the dwelling's insulation.

The temperature control' curves (figure 36) refer to an ambient setting of 20°C.

The slope of the temperature control (parameter 720) determines the impact of the variations in the outdoor temperature on the initial heating temperature variations.

The higher the slope, the more a slight reduction in the outdoor temperature causes a significant increase in the flow water temperature in the heating circuit.

The off-set in the temperature control (parameter 721) modifies the initial temperature of all the curves, without modification of the slope (figure 37).

The corrective actions in the case of any inconvenience are detailed in the table (figure 38).

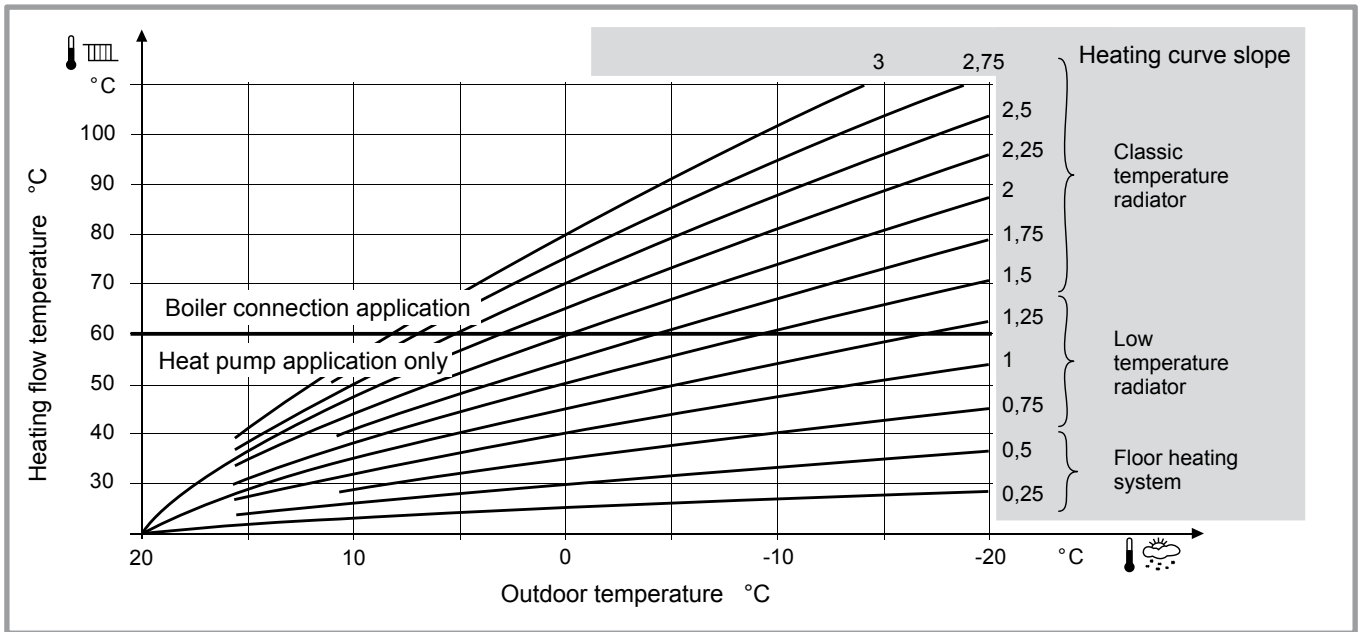

figure 36 - Heating curve slope (line 720)

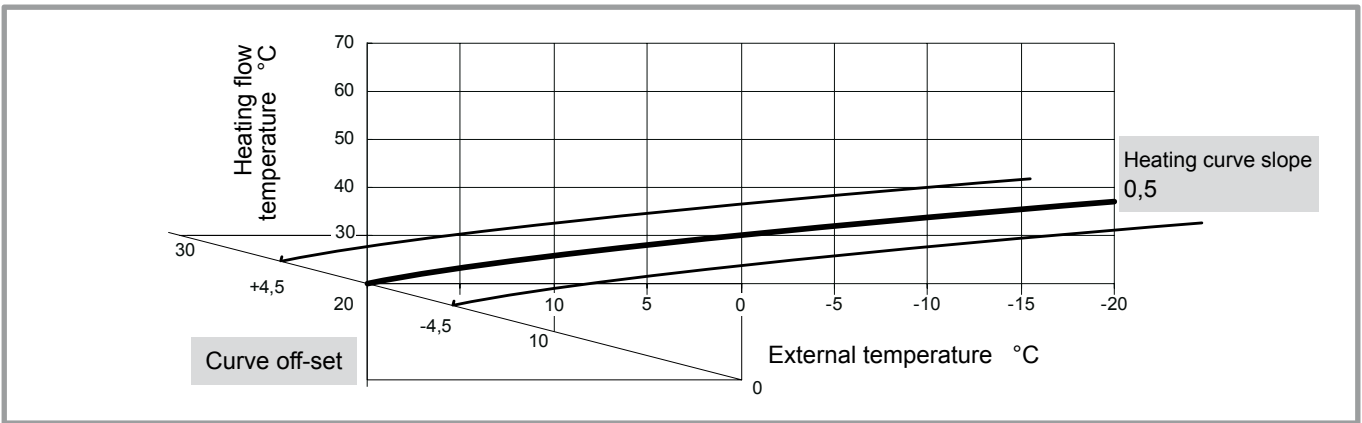

figure 37 - Off-set of the heating curve (line 721)

Sensations...		Corrective actions on the temperature control:	
...in mild weather	...in cold weather	Curve slope (line 720)	Curve off-set (line 721)
OK	& OK	→ No correction	No correction
Cold	& Hot	→	
Cold	& OK	→	
Cold	& Cold	→ No correction	
OK	& Hot	→	No correction
OK	& Cold	→	No correction
Hot	& Hot	→ No correction	
Hot	& OK	→	
Hot	& Cold	→	

figure 38 - Corrective actions in the case of discomfort

3.5 Parametering the setting

3.5.1 General

Only the parameters accessible to levels:

- U** - End user.
- I** - Commissioning level.
- S** - Engineer level.

Are described in this document.

The access levels are specified in the second column of the table by means of the letters **U**, **I** and **S**.

The OEM parameters are not described and require a manufacturer's access code.

3.5.2 Setting parameters

- Choose the desired level.
- Scroll the menu list.
- Choose the desired menu.
- Scroll the function lines.
- Choose the desired line.
- Adjust the parameter
- Check the setting by pressing **OK**.
- To return the menu, press **ESC**.

If no setting is made for 8 minutes, the screen returns automatically to the basic display.

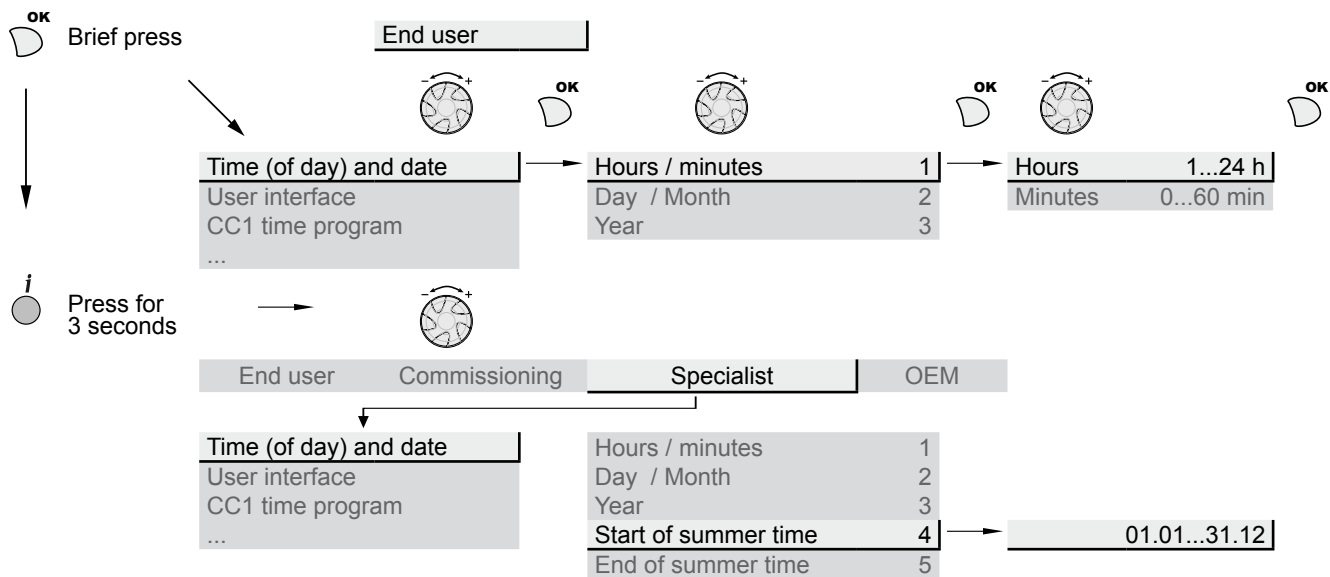

3.5.3 List of function lines (settings, diagnosis, status)

Line	Function	Setting range or display	Setting increment	Basic setting
Time of day and date				
1	U Hours / Minutes	00:00... 23:59	1	
2	U Day / Month	01.01... 31.12	1	
3	U Year	1900... 2099	1	
5	S Start of Summer time (Day / Month)	01.01... 31.12	1	25.03
6	S End of Summer time (Day / Month)	01.01... 31.12	1	25.10
The change of hour will appear at 3:00 first Sunday after the regulated date.				
Operator section				
20	U Language	English, Français, Italiano, Nederlands...		English
22	S Info	Temporary, Permanent		Temporary
26	S Operation locking	On, Off		Off
27	S Programming locking	Off, On		Off
28	S Direct adjustment	automatic storage, ...with confirmation		...with confirmation
29	S Temperature units Pressure units	°C, °F bar, psi		°C bar
70	S Display software version			

<i>Line</i>	<i>Function</i>	<i>Setting range or display</i>	<i>Setting increment</i>	<i>Basic setting</i>
Time program heating circuit 1				
500	U Pre-selection (Day / Week)	Mon-Sun, Mon-Fri, Sat-Sun, Monday, Tuesday, ...		Mon-Sun
501	U 1st phase On (start)	00:00... --:--	10 min	6:00
502	U 1st phase Off (end)	00:00... --:--	10 min	22:00
503	U 2nd phase On (start)	00:00... --:--	10 min	--:--
504	U 2nd phase Off (end)	00:00... --:--	10 min	--:--
505	U 3rd phase On (start)	00:00... --:--	10 min	--:--
506	U 3rd phase Off (end)	00:00... --:--	10 min	--:--
515	U Copy			
516	U Default values, Circuit 1	No, Yes		No
	Yes + OK: The default values memorised in the regulator replace and cancel the customised heating programs. Your customised settings are therefore lost.			
Time program heating circuit 2				
	Only with the 2nd circuit kit option.			
520	U Pre-selection (Day / Week)	Mon-Sun, Mon-Fri, Sat-Sun, Monday, Tuesday, ...		Mon-Sun
521	U 1st phase On (start)	00:00... --:--	10 min	6:00
522	U 1st phase Off (end)	00:00... --:--	10 min	22:00
523	U 2nd phase On (start)	00:00... --:--	10 min	--:--
524	U 2nd phase Off (end)	00:00... --:--	10 min	--:--
525	U 3rd phase On (start)	00:00... --:--	10 min	--:--
526	U 3rd phase Off (end)	00:00... --:--	10 min	--:--
535	U Copy			
536	U Default values, Circuit 2	No, Yes		No
	Yes + OK: The default values memorised in the regulator replace and cancel the customised heating programs. Your customised settings are therefore lost.			
Time program 4 / DHW				
	If the installation is fitted with the DHW kit.			
560	U Pre-selection (Day / Week)	Mon-Sun, Mon-Fri, Sat-Sun, Monday, Tuesday, ...		Mon-Sun
561	U 1st phase On (start)	00:00... --:--	10 min	00:00
562	U 1st phase Off (end)	00:00... --:--	10 min	05:00
563	U 2nd phase On (start)	00:00... --:--	10 min	14:30
564	U 2nd phase Off (end)	00:00... --:--	10 min	17:00
565	U 3rd phase On (start)	00:00... --:--	10 min	--:--
566	U 3rd phase Off (end)	00:00... --:--	10 min	--:--
575	U Copy			
576	U Default values	No, Yes		No
	Yes + OK: The default values memorised in the regulator replace and cancel the customised heating programs. Your customised settings are therefore lost.			

Line	Function	Setting range or display	Setting increment	Basic setting
Time program 5 / Cooling				
If the installation is fitted with the cooling kit (Only with the cooling kit option).				
600	U	Pre-selection (Day / Week)	Mon-Sun, Mon-Fri, Sat-Sun, Monday, Tuesday, ...	Mon-Sun
601	U	1st phase On (start)	00:00... --:--	8:00
602	U	1st phase Off (end)	00:00... --:--	20:00
603	U	2nd phase On (start)	00:00... --:--	--:--
604	U	2nd phase Off (end)	00:00... --:--	--:--
605	U	3rd phase On (start)	00:00... --:--	--:--
606	U	3rd phase Off (end)	00:00... --:--	--:--
615	U	Copy		
616	U	Default values	No, Yes	No
Yes + OK: The default values memorised in the regulator replace and cancel the customised heating programs. Your customised settings are therefore lost.				
Holidays, heating circuit 1 (For the Holiday program is active, the heating mode should be on AUTO).				
641	U	Preselection	Period 1 to 8	Period 1
642	U	Period Start (Day / Month)	01.01... 31.12	1
643	U	Period End (Day / Month)	01.01... 31.12	1
648	U	Operating level	Frost protection, Reduced	Frost protection
Holidays, heating circuit 2 (For the Holiday program is active, the heating mode should be on AUTO).				
If the installation consists of 2 heating circuits (Only with the 2nd circuit kit option).				
651	U	Preselection	Period 1 to 8	Period 1
652	U	Period Start (Day / Month)	01.01... 31.12	1
653	U	Period End (Day / Month)	01.01... 31.12	1
658	U	Operating level	Frost protection, Reduced	Frost protection
Heating, circuit 1				
710	U	Comfort setpoint	Reduced setpoint... Comfort setpoint maximum	0,5 °C 20 °C
712	U	Reduced setpoint	Frost protection setpoint... Comfort setpoint	0,5 °C 19 °C
714	U	Frost protection setpoint	4 °C... Reduced setpoint	0,5 °C 8 °C
716	S	Comfort setpoint maximum	20 °C... 35 °C	1 °C 28 °C
720	I	Heating curve slope (figure 36, page 37)	0,1... 4	0,02 0,5
721	I	Heating curve displacement (figure 37, page 37)	-4,5 °C... 4,5 °C	0,5 °C 0
726	I	Heating curve adaption	Off, On	Off
Warning ! Not to modify, let on "Off".				
730	I	Summer / Winter heating limits	8 °C... 30 °C	0,5 °C 18 °C
When the average of the outside temperatures over the past 24 hours reaches 18°C, the regulator switches off the heating (as an economy measure). During summer mode, the display shows "Eco". This function is only active in automatic mode.				
732	S	24-hour heating limit	-10 °C... 10 °C	1 °C -2 °C
This function enables you partially to offset the automatic summer / winter switchover during the intermediate seasons. Increasing the value delays the switchover to summer regime. Decreasing the value advances the switchover to summer regime. This function is only active in automatic mode.				

Line	Function	Setting range or display	Setting increment	Basic setting
740	I Flow temp setpoint min (for fan convector)	8 °C... Flow temp setpoint max	1 °C	8 °C
741	I Flow temp setpoint max	Flow temp setpoint min... 70 °C	1 °C	55 °C
Floor heating system = 50 °C / Radiators = 65 °C. Important Note : Maximum temperature limitation is not a safety function as required by ground heating.				
750	S Room influence	1%... 100%	1%	50%
If the installation is fitted with a room thermostat: This function enables you to choose the ambient temperature's influence on the setting. If no value is entered, the setting is made based on the temperature control. If the parameter is set at 100%, the setting is only based on the ambient temperature.				
780	S Quick setback	Off, Down to reduced setpoint, Down to frost prot setpoint		Down to reduced setpoint
790	S Optimum start control max (Early start to switch to the comfort setting.)	0... 360 min	10 min	180 min
791	S Optimum stop control max (Early stop to switch from the comfort setting to the reduced setting.)	0... 360 min	10 min	60 min
800	S Reduced setpoint increase start	-30... 10 °C	1 °C	--
801	S Reduced setpoint increase end	-30... 10 °C	1 °C	-5 °C
830	S Mixer valve boost	0... 50 °C	1 °C	0 °C
834	S Actuator running time	30... 873 s	1 s	240 s
850	I Floor curing function (figure 39)			Off
- Off: Early interruption of the current program, program inactive. - Functional heating. - Heating ready for occupation. - Functional heating + Curing heating. - Curing heating + Functional heating. - Manually: Manual mode enables you to programme your own concrete slab drying time. The function ends automatically after 25 days.				
851	I Floor curing setpoint manually (if line 850 = manual)	0... 95 °C	1 °C	25 °C
This function enables you to set the custom concrete slab drying temperature. This temperature remains fixed. The concrete slab-drying program stops automatically after running for 25 days.				
856	I Floor curing day current	0... 32		
857	I Floor curing day completed	0... 32		
900	S Operating mode changeover	None, Protection mode, Reduced, Comfort, Automatic	1	Protection mode

Operating mode at end of concrete slab curing period

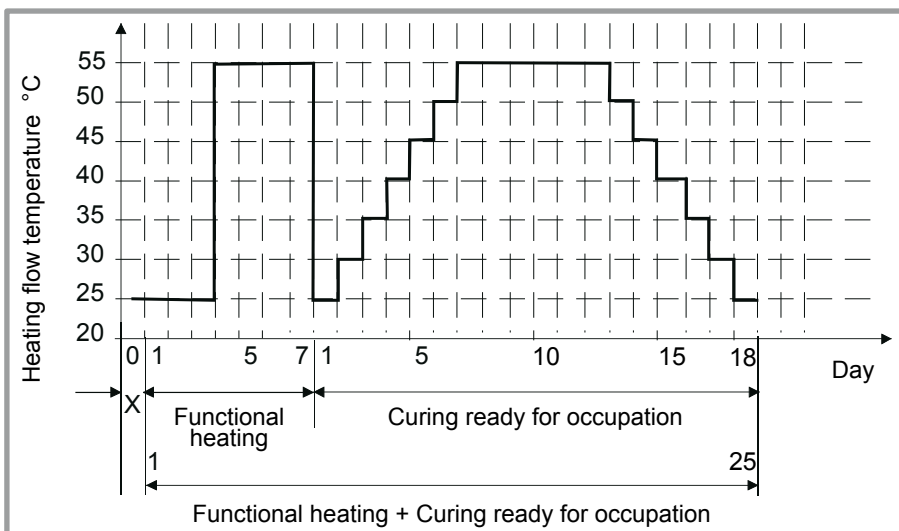

figure 39 - Diagram of the concrete slab curing programs

☞ Please comply with the standards and instructions of the manufacturer of the building ! A good performance of this function is only possible with an installation correctly implemented (hydraulic, electricity and adjustments) ! This function can be stopped by anticipation when setting the adjustment on "Stop".

Line	Function	Setting range or display	Setting increment	Basic setting
Heating, circuit 2				
Only with the 2nd circuit kit option (If the installation consists of 2 heating circuits).				
1010	U Comfort setpoint	Reduced setpoint... Comfort setpoint maximum	0,5 °C	20 °C
1012	U Reduced setpoint	Frost protection setpoint... Comfort setpoint	0,5 °C	19 °C
1014	U Frost protection setpoint	4 °C... Reduced setpoint	0,5 °C	8 °C
1016	S Comfort setpoint maximum	Comfort temp... 35 °C	1 °C	28 °C
1020	I Heating curve slope (figure 36, page 37)	0,1... 4	0,02	0,5
1021	I Heating curve displacement (figure 37, page 37)	-4,5... 4,5 °C	0,5 °C	0 °C
1026	I Heating curve adaption	Off, On		Off
Warning ! Not to modify, let on "Off".				
1030	I Summer / Winter heating limits	8... 30 °C	0,5 °C	18 °C
When the average of the outside temperatures over the past 24 hours reaches 18°C, the regulator switches off the heating (as an economy measure). During summer mode, the display shows "Eco". This function is only active in automatic mode.				
1032	S 24-hour heating limit	-10... 10 °C	1 °C	-2 °C
This function enables you partially to offset the automatic summer/winter switchover during the intermediate seasons. Increasing the value delays the switchover to summer regime. Decreasing the value advances the switchover to summer regime. This function is only active in automatic mode.				
1040	I Flow temp setpoint min (for fan convector)	8... 70 °C	1 °C	8 °C
1041	I Flow temp setpoint max	8... 70 °C	1 °C	55 °C
Floor heating system = 50 °C / Radiators = 65 °C. Important Note : Maximum temperature limitation is not a safety function as required by ground heating.				
1050	S Room influence	1 %... 100 %	1 %	50 %
If the installation is fitted with a room thermostat: This function enables you to choose the ambient temperature's influence on the setting. If no value is entered, the setting is made based on the temperature control. If the parameter is set at 100%, the setting is only based on the ambient temperature.				
1080	S Quick setback	Off, Down to reduced setpoint, Down to frost prot setpoint		Down to reduced setpoint
1090	S Optimum start control max	0... 360 min	10 min	180 min
1091	S Optimum stop control max	0... 360 min	10 min	60 min
1100	S Reduced setpoint increase start	-30... 10 °C, --°C	1 °C	--
1101	S Reduced setpoint increase end	-30... 10 °C, --°C	1 °C	-5 °C
1130	S Mixer valve increase	0... 50 °C	1 °C	0 °C
1134	S Actuator running time	30... 873 s	1 s	240 s
1150	I Floor curing function (figure 39, page 41)			Off
- Off: Early interruption of the current program, program inactive. - Functional heating. - Heating ready for occupation. - Functional heating + Curing heating. - Curing heating + Functional heating. - Manually: Manual mode enables you to programme your own concrete slab drying time. The function ends automatically after 25 days.				
1151	I Floor curing setpoint manually (if line 1150 = manual)	0... 95 °C	1 °C	25 °C
This function enables you to set the custom concrete slab drying temperature. This temperature remains fixed. The concrete slab-drying program stops automatically after running for 25 days.				
1156	I Floor curing day current	0... 32		
1157	I Floor curing day completed	0... 32		0

Line	Function	Setting range or display	Setting increment	Basic setting
1200	S Operating mode changeover	None, Protection mode, Reduced, Comfort, Automatic		Protection mode
Operating mode at end of concrete slab drying period.				
Domestic hot water				
If the installation is fitted with the DHW kit.				
1610	U Nominal setpoint	Reduced setpoint (line 1612)... 65 °C	1	55 °C
The backup electrical system is required to reach this level.				
1612	U Reduced setpoint	8 °C... Nominal setpoint (line 1610)	1	40 °C
1620	I Release (of DHW load)	24h / day Time program HCs Time program 4 / DHW Low-tariff (Off-peak) T*prog 4 / DHW or Low-tariff		Time program 4 / DHW
24h / day: The temperature of the DHW is constantly maintained at the DHW comfort setting.				
Time program HCs: The DHW is produced according to the programming for the ambient temperature (with 1 hour in advance when switched on).				
Time program 4 / DHW: The DHW program is separate form the heating circuit program.				
Low-tariff* : The electrical backup heating is only authorised to operate during the off-peak period.				
T*prog 4/DHW or low-tariff*: The electrical backup heating is authorised to operate during the comfort period or off peak.				
* - Connect the "Power Provider" contact to input EX2 (see figure 31, page 28). In the case of a day /night contract, the electric back-ups for the DHW tank are subject to the power supplier's tariffs. Switching on the electric back-up for the DHW tank is only authorised during off-peak hours.				
1640	I Legionella function	Off, Periodically (depending line setting 1641), Fixed weekday (depending line setting 1642)		Off
1641	S Legionella function periodically	1 to 7	1 day	7
1642	S Legionella function weekday	Monday, Tuesday,...		Sunday
Swimming pool (Only with swimming pool kit option)				
2056	U Setpoint source heating	8... 35 °C		22 °C
Heat pump (HP)				
2803	S Overrun time cond pump	8... 240 s	1 s	240s
2843	S Compressor off time min	0... 120 min	1 °C	8 min
2844	S Switch-off temp max	8... 100 °C	1 °C	75 °C
2862	S Locking time stage 2 / mod	0... 40 min	1 min	5 min
2873	S Compressor mod run time	10... 600 s	1 s	240 s
2882	S Release integr electric flow	0... 500 °Cmin	1 °Cmin	100 °Cmin
2884	S Release el flow below OT Electrical release - start-up with outside temperature	-30... 30 °C		2 °C
2886	S Compensation heat deficit	Off, On, Only with floor curing fct		Off
2916	S Max setpoint HP DHW charg	8... 80 °C		60 °C
2920	S With electrical utility lock (EX1)	Locked (Blocked on standby), Released		Released
Released : HP = ON _ Back-up DHW = off _ 1st back-up HP = off _ 2nd back-up HP = off _ Boiler = ON Locked (Blocked on standby) : HP = off _ Back-up DHW = off _ 1st back-up HP = off _ 2nd back-up HP = off _ Boiler = ON				

Line	Function	Setting range or display	Setting increment	Basic setting
Supplementary source (Boiler connection)				
3700	S Release below outside temperature	-50... 50 °C	1 °C	2 °C
3701	S Release above outside temperature	-50... 50 °C	1 °C	--
3705	S Overrun time	0... 120 min	1 min	20 min
3720	S Switching integral (for boiler relief)	0... 500 °Cmin	1 °Cmin	100 °Cmin
3723	S Locking time	1... 120 min	1 min	30 min
DHW storage tank				
If the installation is fitted with the DHW kit.				
5024	S Switching diff	0... 20 °C	1 °C	7 °C
5030	S Charging time limitation	10... 600 min	10 min	90 min
5055	S Recooling temp	10... 95 °C	1 °C	65 °C
5057	S Recooling collector	Off, Summer, Always		Summer
5061	S Electric immersion heater release	24h / day, DHW release, Time program 4 / DHW		DHW release
5093	S Not used			
Installation configuration				
5700	I Pre-setting	1,2,3,... 9	1	1
This control enables you to choose one of the 4 pre-selected installation configurations. The hydraulic layouts for the various configurations are detailed in the section: "Installation Configurations".				
- Pre-setting 1: 1 heating circuit with or without DHW tank.				
- Pre-setting 2: 2 heating circuits with or without DHW tank.				
- Pre-setting 3: Boiler connection and 1 heating circuit and with or without DHW tank.				
- Pre-setting 4: Boiler connection and 2 heating circuits and with or without DHW tank.				
- Pre-setting 5 and more: Not used.				
5710	S Heating circuit 1	Off, On		On
5711	S Cooling circuit 1	Off, System with 4 tubes, System with 2 tubes		Off
5715	S Heating circuit 2	Off, On		On
5731	S DHW controlling element Q3	No charging request, Charging pump, Diverting valve		Diverting valve
5806	I Type el imm heater flow	1 : 3-stage, 2 : 2-stage excluding, 3 : 2-stage complementary, 4 : Modulating UX		3 : 2-stage complementary
5981	S Contact type input EX1	Normally-closed contact (NC) Normally-opened contact (NO)		NO
5983	S Contact type input EX2	Normally-closed contact (NC) Normally-opened contact (NO)		NC
5985	S Contact type input EX3	Normally-closed contact (NC) Normally-opened contact (NO)		NO
6098	S Not used			
6100	S Readjustm outside sensor	-3... 3 °C	0,1 °C	0 °C
6120	S Frost protection plant	On, Off		On
6205	S Reset to default parameters	No, Yes		No
6220	S Software version (RVS)	0... 99		--
6420	S Function input H33 (= contact in X152)	1... 56		1
(1) Mode changeover HC+DHW - (2) Mode changeover HC - (3) Mode changeover HC1 - (4) Mode changeover HC2 - (5) Mode changeover HCP - (6) to (10) Not used - (11) Mode changeover Heating Swimming pool - (12) to (56) Not used.				
6421	S Contact type H33	Normally-closed contact (NC) Normally-opened contact (NO)		NO

Line	Function	Setting range or display	Setting increment	Basic setting
LPB system				
6600	S Not used			
Error				
6711	U Reset HP	No, Yes		No
6800	S History 1	Time, Date, Error code		
6802	S History 2	Time, Date, Error code		
6804	S History 3	Time, Date, Error code		
6806	S History 4	Time, Date, Error code		
6808	S History 5	Time, Date, Error code		
6810	S History 6	Time, Date, Error code		
6812	S History 7	Time, Date, Error code		
6814	S History 8	Time, Date, Error code		
6816	S History 9	Time, Date, Error code		
6818	S History 10	Time, Date, Error code		
Maintenance / special regime				
7070	S HP interval	--, 1... 240	1 month	--
7071	S HP time since maint Reset ? (no, yes)	0... 240	1 month	0
7073	S Cur starts compr1/hrs run (since the 6 last weeks) Reset ? (no, yes)	0... 12		0
7141	U Emergency operation	Off, On		Off
	Off: Heat pump functions normally (with boosters if necessary). On: Heat pump uses the electric boost system or the boiler connection. Use the "On" position only in Assist mode or Test mode: may result in high power bills.			
7142	S Emergency operating function type	Manual, Automatic		Manual
	Manual: Emergency mode is not active when a fault occurs (Emergency mode = OFF). Automatic: Emergency mode is active when a fault occurs (Emergency mode = ON). In "Automatic" position, the energy cost can be onerous if the error is not detected and eliminated.			
7150	I Simulation outside temp	-50... 50 °C	0,5	--
Inputs / outputs test				
7700	I Relay test			0
	This consists of instructing the regulator's relays one by one and checking their outputs. This enables you to check that the relays are working and that the cabling is correct. Check that each appliance in the installation is operating correctly. (0) No test, (1) Everything is on STOP, (2) Relay output QX1 : heat pump CC1 (Main regulation board), (3) Relay output QX2 : Electrical back-up (1st stage) or Boiler connection distribution valve, (4) Relay output QX3 : Electrical back-up (2nd stage) or Boiler connection contact, (5) Relay output QX4 : DHW distribution valve, (6) Relay output QX5 : DHW Electrical back-up, (7) Relay output QX6 , (8) Relay output QX31 : Heat circ mix valve open Y1 (or Control pilot-wire), (9) Relay output QX32 : Heat circ mix valve close Y2, (10) Relay output QX33 : heat pump CC2, (11) Relay output QX34, (12) Relay output QX35 : Swimming pool distribution valve, (13) Relay output QX21 module 1, (14) Relay output QX22 module 1, (15) Relay output QX23 module 1, (16) Relay output QX21 module 2, (17) Relay output QX22 module 2, (18) Relay output QX23 module 2, (19) Not used, (20) Not used, (21) Not used.			
	The display shows the "Key" symbol. Pressing the Info button displays "Error 368". Warning: The component being tested is receiving electrical power throughout the test.			
7710	I Output UX1 test	0... 100%	1	--
7712	I PWM signal UX1	0... 100%	1	0
7716	I Output UX2 test	0... 100%	1	--
7719	I PWM signal UX2	0... 100%	1	0
7722	I Cooling mode D2	Off, On		Off
7723	I Heat pump D3	Off, On		Off

Line	Function	Setting range or display	Setting increment	Basic setting
7724	I Outputs test UX3 ("Inverter" command)	0... 100 %		--
7725	I Voltage value (UX3)	0... 10 v		--
7820	I Sensor temperature BX1 (HP flow temperature)	-28... 350 °C		--
7821	I Sensor temperature BX2 (HP return temperature)	-28... 350 °C		--
7822	I Sensor temperature BX3 (DHW temperature)	-28... 350 °C		--
7823	I Sensor temperature BX4 (Outside temperature)	-28... 350 °C		--
7824	I Sensor temperature BX5	-28... 350 °C		--
7825	I Sensor temperature BX6	-28... 350 °C		--
7830	I Sensor temperature BX21 module 1	-28... 350 °C		--
7832	I Sensor temperature BX21 module 2	-28... 350 °C		--
7849	I Contact status H2, module 2	Open, Closed		Open
7911	I Input EX1 (Power shedding, EJP)	0, 230 V		--
7912	I Input EX2 (Tariffs day/night)	0, 230 V		--
7913	I Input EX3 (External fault)	0, 230 V		--
7973	I Sensor temperature BX31 (Mixing circuit temp.)	-28... 350 °C		--
7974	I Sensor temperature BX32	-28... 350 °C		--
7975	I Sensor temperature BX33	-28... 350 °C		--
7976	I Sensor temperature BX34 (Swimming pool exchanger temperature)	-28... 350 °C		--
7977	I Sensor temperature BX35	-28... 350 °C		--
7978	I Sensor temperature BX36	-28... 350 °C		--
7996	I Contact status H33	Open, Closed		Open
State				
8000	I State heating circuit 1			--
8001	I State heating circuit 2			
8003	I State DHW			--
8004	I State cooling circuit 1			
8006	I State heat pump			--
8007	I Not used			
8010	I Not used			
8011	I State swimming pool			
8022	I State supplementary source			--
Diagnostics heat generation				
8402	I EI imm heater flow 1	Off, On		Off
8403	I EI imm heater flow 2	Off, On		Off
8406	I Condenser pump	Off, On		Off
8410	U Return temp HP	0... 140 °C		--
	Setpoint (flow) HP			--
8412	U Flow temp HP	0... 140 °C		--
	Setpoint (flow) HP			--
8413	U Compressor modulation	0... 100%		--
8414	I Modulation electric flow	0... 100%		--

Line	Function	Setting range or display	Setting increment	Basic setting
8425	S Temp diff condensor	-50... 140 °C		--
8454	S Locking time Heat Pump Reset ? (no, yes)	0... 2730 h		--
8455	S Counter number of locks HP Reset ? (no, yes)	0... 65535		--
8456	S Hours run electrical flow Reset ? (no, yes)	0... 2730 h		--
8457	S Start counter electrical flow Reset ? (no, yes)	0... 65535		--
8499	S Not used			
8505	S Not used			
8510	S Not used			
8511	S Not used			
8512	S Not used			
8513	S Not used			
8515	S Not used			
Diagnostics consumers				
8700	U Outside temperature	-50... 50 °C		--
8701	U Outside temp min Reset ? (no, yes)	-50... 50 °C		--
8702	U Outside temp max Reset ? (no, yes)	-50... 50 °C		--
8703	I Outside temp attenuated Reset ? (no, yes)	-50... 50 °C		--
	This is the average of the outside temperature over a 24-hour period. This value is used for automatic Summer / Winter switchover (line 730).			
8704	I Outside temp composite	-50... 50 °C		--
	The mixed outside temperature is a combination of the current outside temperature and the average outside temperature calculated by the regulator. This value is used for calculating the initial temperature.			
8730	I Heating circuit pump, circuit 1	Off, On		Off
8731	I Mixer valve HC1 open	Off, On		Off
8732	I Mixer valve HC1 closed	Off, On		Off
8740	U Room temperature 1	0... 50 °C		--
	Room setting 1			20 °C
8743	U Flow temperature 1	0... 140 °C		--
	Flow temperature setpoint 1			--
8756	U Cooling flow temperature 1	0... 140 °C		--
	Cooling flow temperature setpoint 1			--
8760	I Heating circuit pump, circuit 2	Off, On		Off
8770	U Room temperature 2	0... 50 °C		--
	Room setpoint 2			20 °C
8773	U Flow temperature 2	0... 140 °C		--
	Flow temperature setpoint 2			--
8820	I DHW pump	Off, On		Off
8821	I El imm heater DHW	Off, On		Off

Line	Function	Setting range or display	Setting increment	Basic setting
8830	U DHW (domestic hot water) temperature	0... 140 °C		--
	DHW temperature setpoint			50 °C
8840	S Hours run DHW pump	0... 2730 h		--
8841	S Start counter DHW pump	0... 199999		--
8842	S Hours run electric DHW	0... 2730 h		--
8843	S Start counter electric DHW	0... 65535		--
8900	U Swimming pool temperature	0... 140 °C		--
	Swimming pool temperature setpoint			22 °C
8950	S Common flow temperature	0... 140 °C		--
	Common flow temperature setpoint			--
8957	S Common flow setpoint, refrigeration	0... 140 °C		--
8980	S Not used			
8981	S Not used			
9031	I Relay output QX1	Off, On		On
9032	I Relay output QX2	Off, On		On
9033	I Relay output QX3	Off, On		On
9034	I Relay output QX4	Off, On		Off
9035	I Relay output QX5	Off, On		Off
9050	I Relay output QX21 module 1	Off, On		Off
9051	I Relay output QX22 module 1	Off, On		Off
9052	I Relay output QX23 module 1	Off, On		Off
9053	I Relay output QX21 module 2	Off, On		Off
9054	I Relay output QX22 module 2	Off, On		Off
9055	I Relay output QX23 module 2	Off, On		Off
9071	I Relay output QX31	Off, On		On
9072	I Relay output QX32	Off, On		On
9073	I Relay output QX33	Off, On		Off
9074	I Relay output QX34	Off, On		Off
9075	I Relay output QX35	Off, On		Off



A series of horizontal lines spanning the width of the page, providing a space for handwritten notes or instructions.

4 Overall hydraulic layout

• Configuration 1: 1 heating circuit

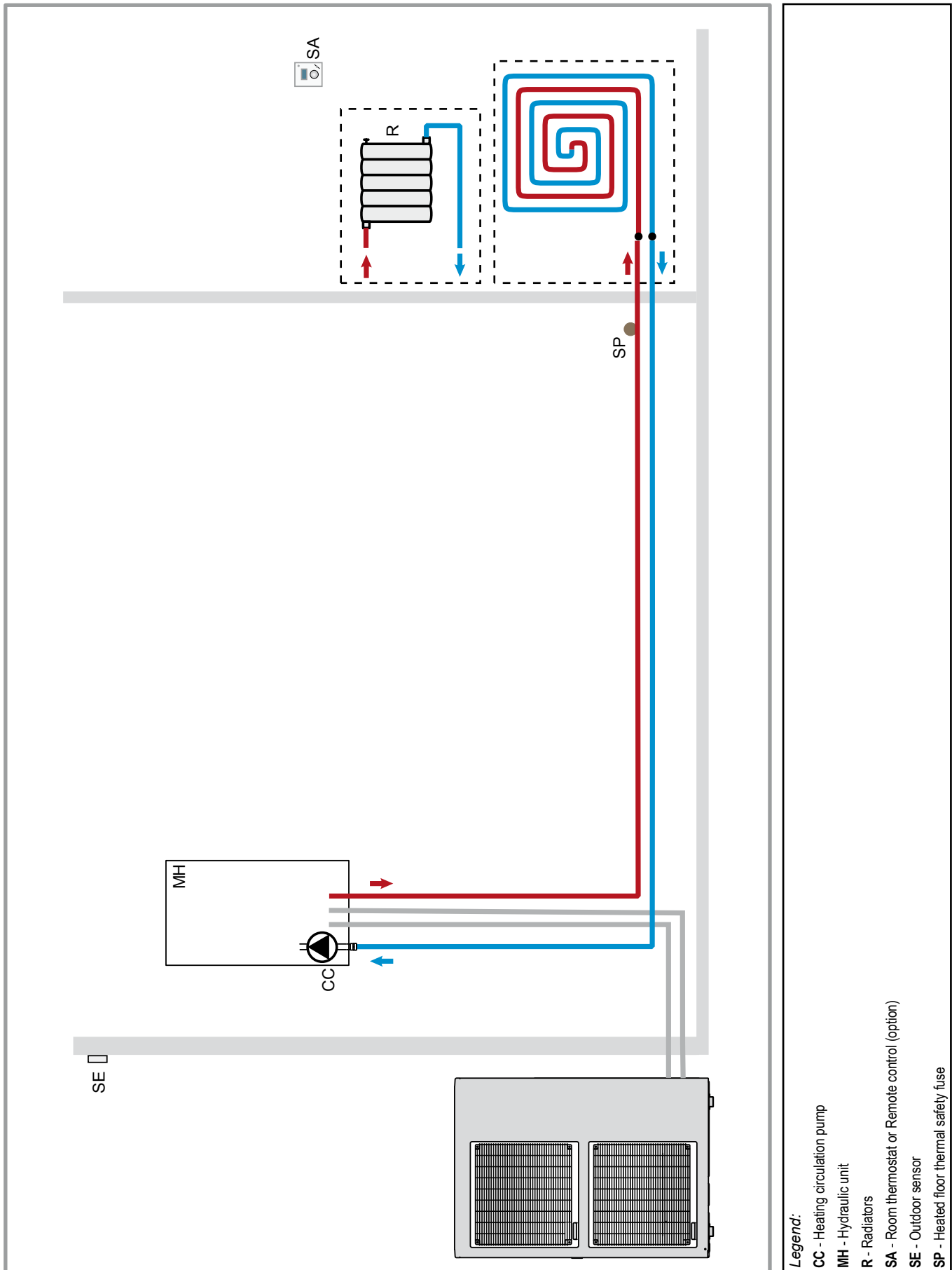

Legend:

- CC - Heating circulation pump
- MH - Hydraulic unit
- R - Radiators
- SA - Room thermostat or Remote control (option)
- SE - Outdoor sensor
- SP - Heated floor thermal safety fuse

• Configuration 1: 1 heating circuit and DHW tank (with electrical back-up)

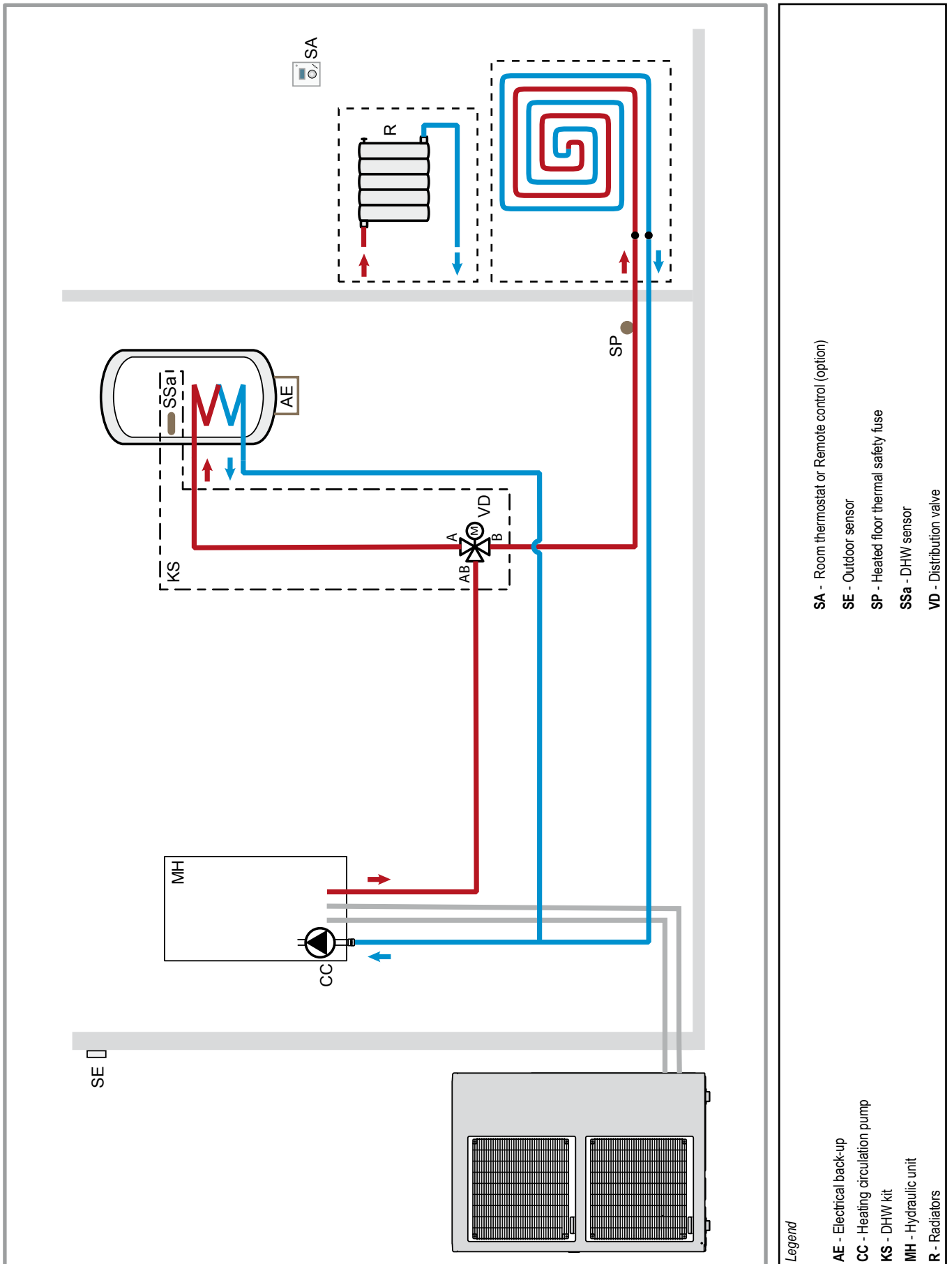

5 Electrical wiring diagrams

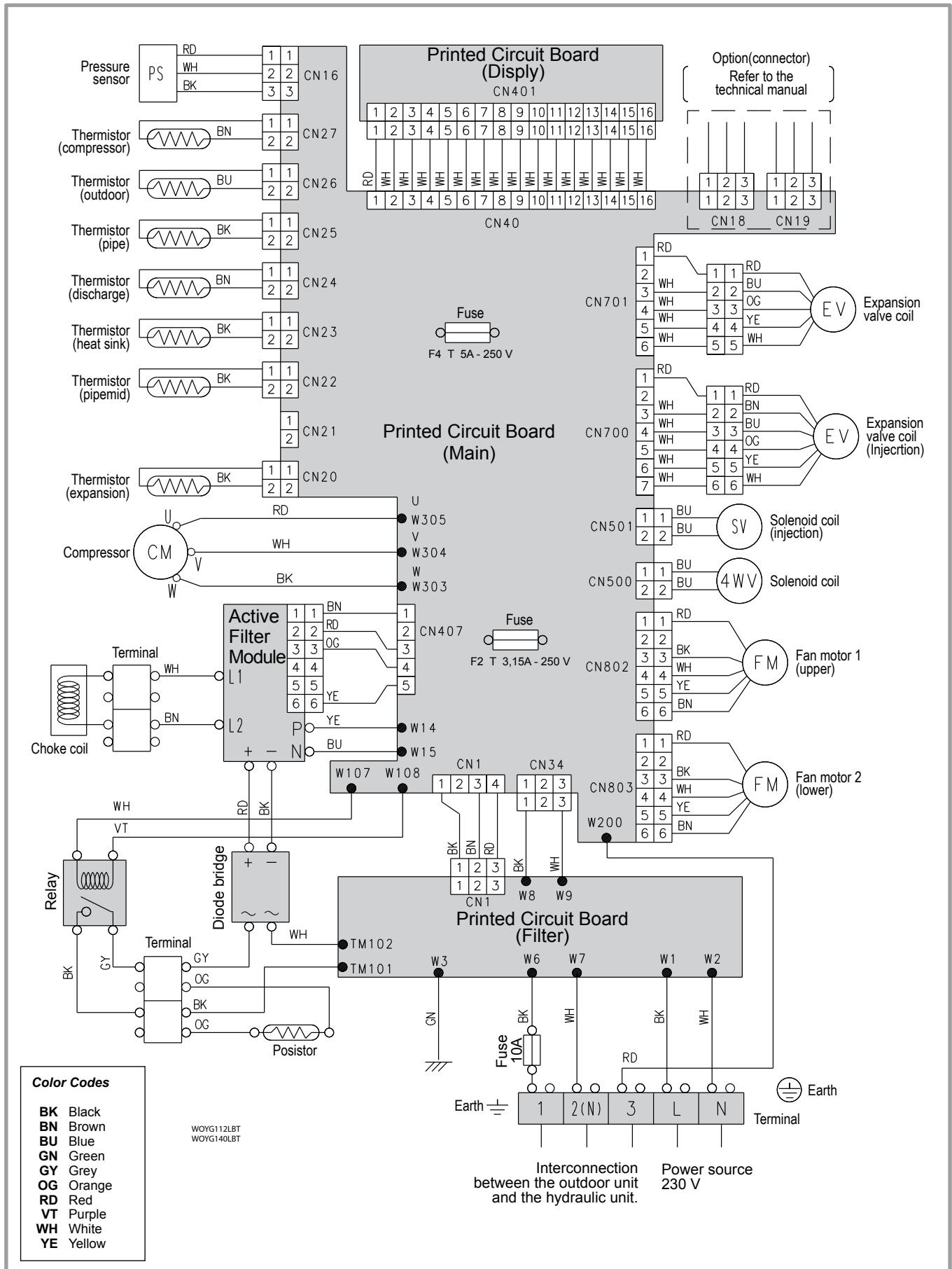

figure 40 - Electrical wiring of outside unit Single phase Waterstage

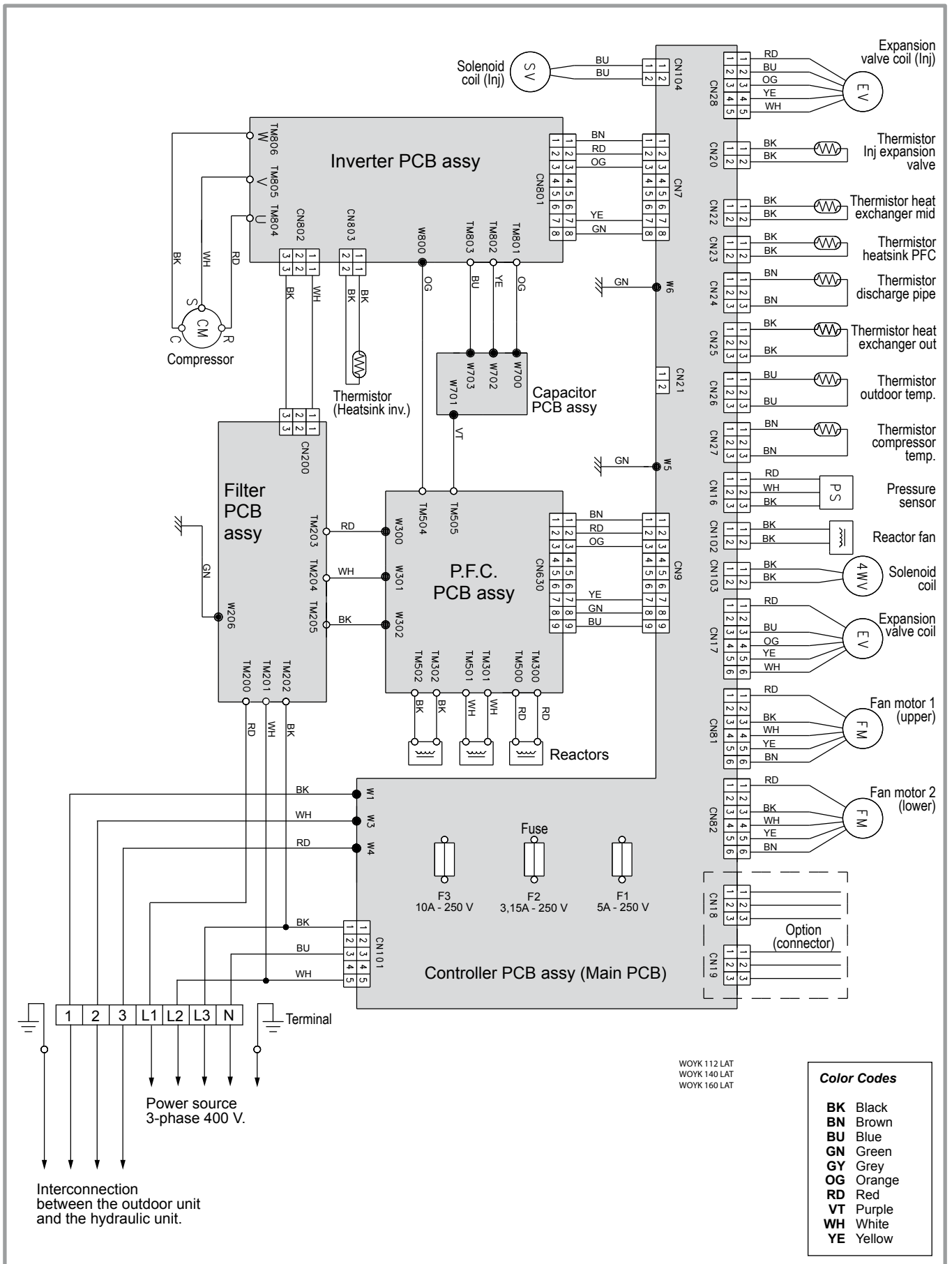

figure 41 - Electrical wiring of outside unit 3-phase type Waterstage

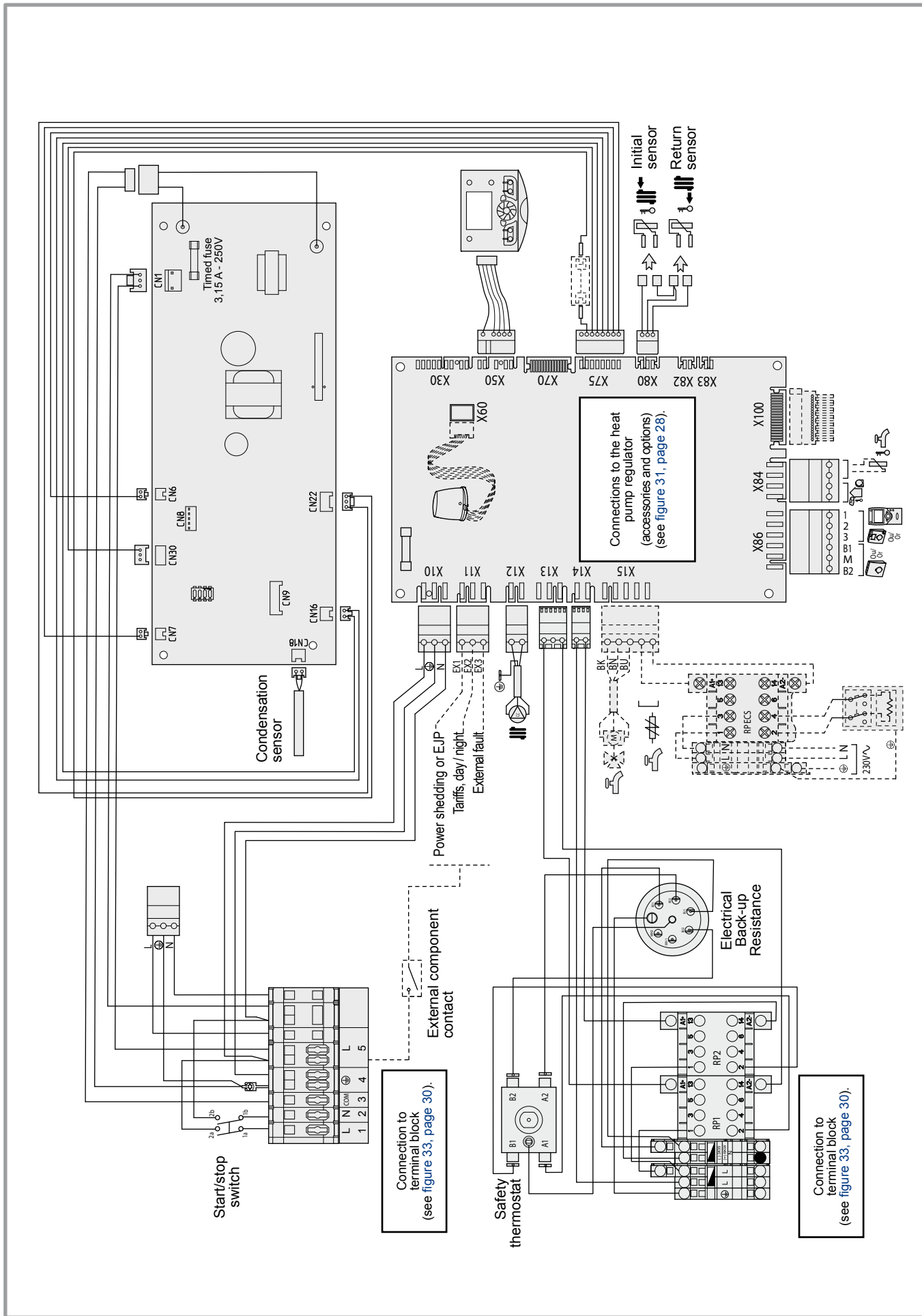

figure 42 - Electrical wiring, Hydraulic unit HP single phase (Except installer's connections)

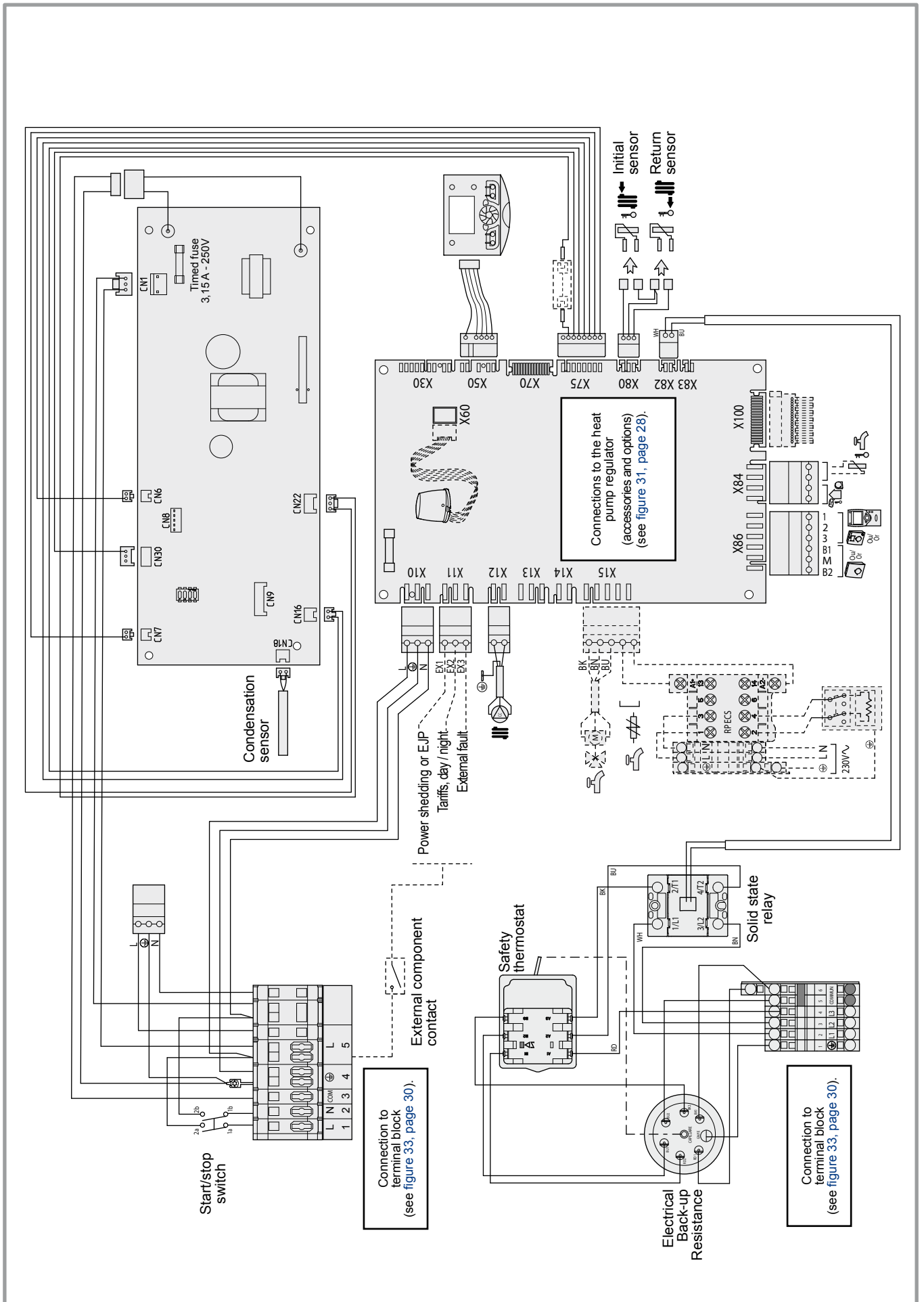

figure 43 - Electrical wiring, Hydraulic unit HP 3-phase (Except installer's connections)

6 Troubleshooting

Depending on whether the fault comes from the outdoor unit or the hydraulic unit, the fault may be indicated by the digital display or the diode on the interface cards.

6.1 Faults displayed on the hydraulic unit

Faults or breakdowns on the hydraulic unit are indicated by the display on the user interface.

The display shows the  symbol.

Press the  key for more details on the origin of the fault.

When the error has been resolved, the faults are re-initialised at zero automatically.

Hydraulic unit: Fault visible on the digital display.

Error number	Error description	Error location	Heat pump operation despite the error
-	No connection.	Failure to comply with room thermostat's polarity.	No
10	Outdoor sensor.	X86	Yes with OT = 0 °C
33	Heat pump initial temperature sensor error.	X70	Yes
44	Heat pump return temperature sensor error.	X70	Yes
50	DHW temperature sensor.	X84	Yes
60	Ambient temperature sensor 1.		Yes
65	Ambient temperature sensor 2.		Yes
105	Maintenance message.		Yes
121	Flow temperature for (HC1) not reached.		Yes
122	Flow temperature for (HC2) not reached.		Yes
127	Anti-legionella temperature not reached.		Yes
369	External fault (safety component).		No
370	Outside unit connection error. (In the start phase, see the para. "Start-up").	See below and page 58 & 59 .	No

Hydraulic unit: Flashing of the diode visible on the interface card.

Diodes display		Error contents
LED 2 (green)	LED 1 (red)	
1 Flash	1 Flash	Communication error between Hydraulic unit and Outdoor unit.
4 Flashes	1 Flash	Heat pump capacity signal error (Open or short).
4 Flashes	2 Flashes	Hydraulic unit heat-exchange thermistor Error.
6 Flashes	3 Flashes	Inverter error.
6 Flashes	4 Flashes	Active filter error.
7 Flashes	1 Flash	Discharge thermistor error.
7 Flashes	2 Flashes	Compressor thermistor error.
7 Flashes	3 Flashes	Heat-exchange thermistor (outlet / intermediate) error.
7 Flashes	4 Flashes	Outdoor thermistor error.
7 Flashes	7 Flashes	Heat sink thermistor error.
7 Flashes	8 Flashes	Expansion valve thermistor error.
8 Flashes	4 Flashes	Current sensor error.
8 Flashes	6 Flashes	Pressure sensor error / Pressure switch error.
9 Flashes	4 Flashes	Current trip.
9 Flashes	5 Flashes	Detection of compressor position error / Compressor start up error.
9 Flashes	7 Flashes	Outdoor unit fan motor error.
10 Flashes	1 Flashes	Discharge temperature protection.
10 Flashes	3 Flashes	Compressor temperature protection.
10 Flashes	5 Flashes	Low pressure abnormal.
Continuous flashing (1 sec On / 1 sec Off)		Pump down operation.
Continuous lighting	Off	Defrosting.

6.2 Information display

Various data can be displayed by pressing the info button.

Depending on the type of unit, configuration and operating state, some of the info lines listed below may not appear.

- Possible error messages from the error code list (see table, [page 56](#)).
- Possible service messages from the maintenance code list.
- Possible special mode messages.
- Various data (see below).

Designation	Line
Floor drying current setpoint .	-
Current drying day.	-
Terminated drying days.	-
State heat pump.	8006
State supplementary source.	8022
State DHW.	8003
State swimming pool.	8011
State heating circuit 1.	8000
State heating circuit 2.	8001
State cooling circuit 1.	8004
Outdoor temperature.	8700
Room temperature 1.	8740
Room setpoint 1.	
Flow temperature 1.	8743
Flow temperature setpoint1.	
Room temperature 2.	8770
Room setpoint 2.	
Flow temperature 2.	8773
Flow temperature setpoint 2.	
DHW (domestic hot water) temperature.	8830
Heat pump return temperature.	8410
Setpoint (return) HP.	
Heat pump flow temperature.	8412
Setpoint (flow) HP.	
Swimming pool temperature.	8900
Swimming pool temperature setpoint.	
Minimum remaining stop time for compressor 1.	-
Minimum remaining running time for compressor 1.	-

6.3 Faults displayed on the single phase outdoor unit

To access the electronic board, you must remove the front (right-hand) facing from the outdoor unit.

Faults are coded by diode flashes.

When an error occurs:

- The diode "**ERROR**" (2) blinks.
- Press once on the switch "**ENTER**" (SW3).
- The "**ERROR**" (2) diode blinks several times depending on the error's type (see below).

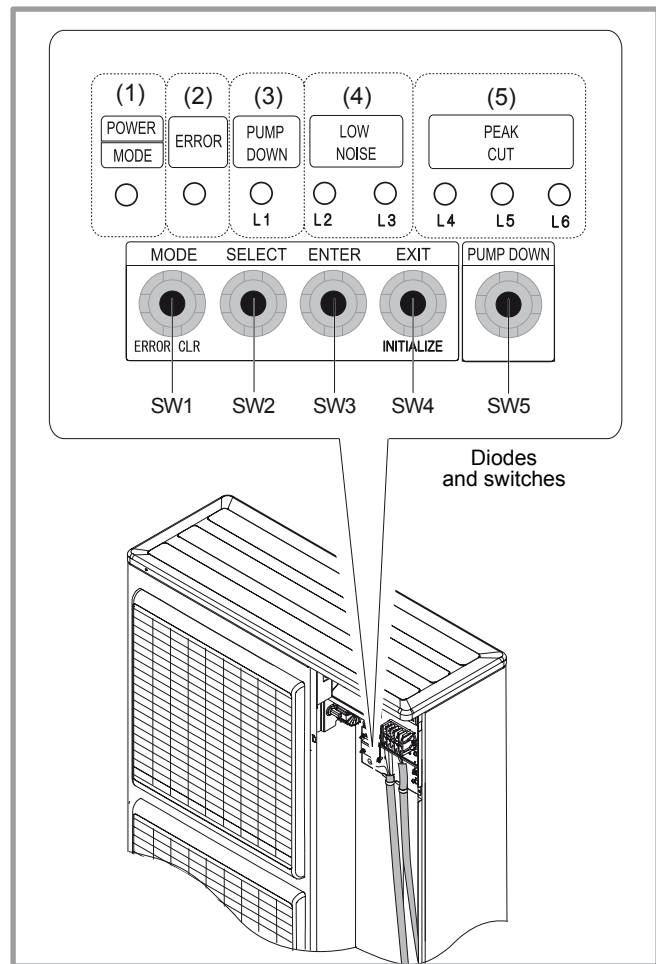

figure 44 - Location of switches and diodes on single phase outdoor unit

Diode display	Error contents
1 Flash	Serial forward transfer error.
2 Flashes	Discharge thermistor error.
3 Flashes	Pressure sensor error.
4 Flashes	Heat-exchange thermistor (outlet) error.
5 Flashes	Heat-exchange thermistor (intermediate) error.
6 Flashes	Expansion valve thermistor error.
7 Flashes	Outdoor temperature thermistor error.
8 Flashes	Compressor thermistor error.
9 Flashes	Heat sink thermistor error.
11 Flashes	Discharge temperature protection (permanent stoppage).
12 Flashes	Compressor temperature protection (permanent stoppage).
13 Flashes	Current trip (permanent stoppage).
14 Flashes	Detection of compressor position error (permanent stoppage).
15 Flashes	Compressor start up error (permanent stoppage).
16 Flashes	Fan motor 1 error (permanent stoppage).
17 Flashes	Fan motor 2 error (permanent stoppage).
18 Flashes	Inverter error.
19 Flashes	Active filter error.
20 Flashes	Low pressure abnormal.
21 Flashes	Connection with hydraulic unit error.
22 Flashes	Hydraulic unit abnormality condition.

- ☞ Ensure that the general electrical power supply has been cut off before starting any repair work.
- ☞ When the HP is not under tension, protection frost-free is not assured.

6.4 Faults displayed on the 3-phase outdoor unit

To access the electronic board, you must remove the front (right-hand) facing from the outdoor unit.

Faults are coded by diode flashes.

When an error occurs:

- The diode "ERROR" (2) blinks.
- Press once on the switch "ENTER" (SW4).
- The "ERROR" (2) diode blinks several times depending on the error's type (see below).

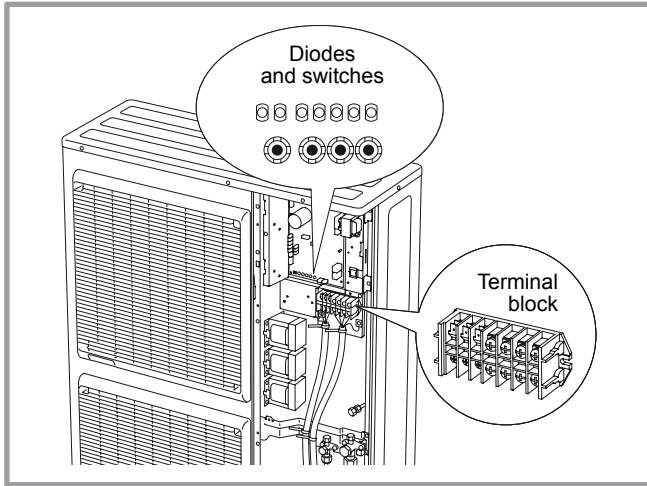

figure 45 - Location of switches and diodes on 3-phase outdoor unit

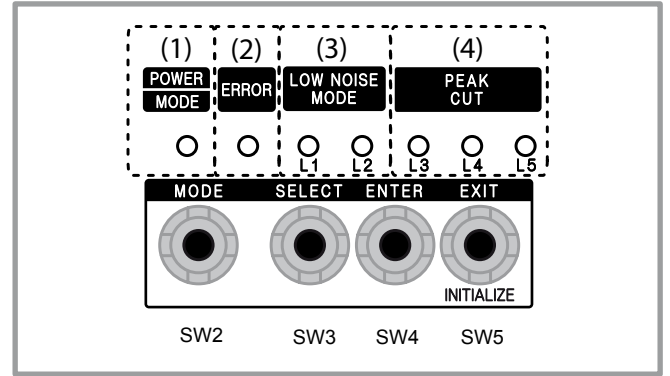

figure 46 - LED display on the 3-phase outdoor unit

Diode display	Error contents
1 Flash	Serial forward transfer error.
2 Flashes	Discharge thermistor error.
3 Flashes	Pressure sensor error.
4 Flashes	Heat-exchange thermistor (outlet) error.
5 Flashes	Heat-exchange thermistor (intermediate) error.
6 Flashes	Expansion valve thermistor error.
7 Flashes	Outdoor temperature thermistor error.
8 Flashes	Compressor thermistor error.
9 Flashes	Heat sink thermistor (inverter) error.
10 Flashes	Heat sink thermistor (P.F.C.) error.
11 Flashes	Discharge temperature protection (permanent stoppage).
12 Flashes	Compressor temperature protection (permanent stoppage).
13 Flashes	Current trip (permanent stoppage).
14 Flashes	Detection of compressor position error (permanent stoppage).
15 Flashes	Compressor start up error (permanent stoppage).
16 Flashes	Fan motor 1 error (permanent stoppage).
17 Flashes	Fan motor 2 error (permanent stoppage).
18 Flashes	Inverter error.
19 Flashes	P.F.C. error.
20 Flashes	Low pressure abnormal.
21 Flashes	Connection with hydraulic unit error.
22 Flashes	Hydraulic unit abnormality condition.

7 Quick-start procedure

Before switching on the hydraulic unit:

- Check the electric wiring.
- Check the refrigeration circuit and make sure the gas supply has been performed.
- Check the pressure of the hydraulic circuit (1-2 bar), check that the heat pump is purged, and the rest of the installation.
- Make sure that ALL DIPSW on the interface card are OFF before starting up.

7.1 Start-up check-list

7.1.1 Before starting-up

• Sight checks

Outdoor unit (see chapter "Installation of the outdoor unit" page 12).	OK	Non compliant	
Location and fittings, condensate evacuation.			
Compliance with distances from obstacles.			

• Hydraulic checks

Hydraulic unit (see chapter "Installing the hydraulic unit" page 15).	OK	Non compliant	Value
Connection of pipes, valves and pumps (1 or 2 circuits, DHW).			
Installation water volume (expansion vessel of adequate capacity ?).			
No leaks.			
Main system pressure and degassing.			

• Refrigeration connections and checks

(see chapters "Refrigeration connections" page 16 & "Filling the installation with gas" page 19).	OK	Non compliant	
Connections between units (pipe length, flare tightening torque...).			
Installation of HP, LP pressure switches on liquid line (small pipe).			
Pump down required.			
Nitrogen leak test (~ 10 bar).			
Opening of refrigeration valves to outdoor unit.			
Refrigerant filling of hydraulic unit and pipes.			

• Electrical checks

Outdoor unit (see chapter "Electrical connections" page 24).	OK	Non compliant	Value
Main power supply (230v or 400v).			
Protection by rated circuit breaker.			
Cable cross-section.			
Earth connection.			

Hydraulic unit (see chapter "Electrical connections on the hydraulic unit side" page 28).	OK	Non compliant	
Connection with outdoor unit (phase, neutral, earth or 3 phases + earth).			
Sensors connection (positioning and connections).			
3 way valve and circulators connections.			
Power supply and protection of electric auxiliary.			

7.1.2 Starting-up

• Switching On

(see chapter "Star-up" [page 31](#) & chapter "List of function lines (settings, diagnosis, status)", [page 38](#)).

	OK	Non compliant	
Close the installation's main circuit breaker (power supply to the outdoor unit) <u>2 hours before starting up the tests</u> => The compressor to pre-heat.			
Turn ON the start/stop switch => Initialisation for a few seconds.			
Operation of the heating pump.			
Outdoor unit starts after 4 mins.			
Configure Time, Date and time programs for HC1, HC2 if different than default values.			
Configure the hydraulic circuit (setting 5700)			
Ajust the heating curve slope (720 & 1020)			
Adjust the maximum start setting (741 & 1041)			

• Outdoor unit checks

	OK	Non compliant	Value
Operation of fan(s), compressor.			
Current measurement.			
After a few minutes, measurement of air temp. delta.			
Check condensation and evaporation pressure/temperature.			

• Hydraulic unit checks

	OK	Non compliant	Value
After 15 mins of operation.			
Primary water temp. delta.			
Operation of heating, mixing valve, boiler backup, ...			

• Remote control

(see chapter "Configuring the room thermostat" [page 32](#) & chapter [3.4.3 page 38](#)).

	OK	Non compliant	
Settings, manipulations, checks.			
Set the scheduled periods for heating (500 to 516 & 520 to 536).			
Adjust the heating setpoints (710 - 714 ; 1010-1014), if different than default values.			
Setpoint display.			
Explanations on use.			

The heat pump is ready for operation !

7.2 Settings sheet

Setting	Description	Set to.	Menus
Preliminary settings			
20	language		<i>operator section</i>
1	hour / minutes		<i>time & date</i>
2	day / month		<i>time & date</i>
3	year		<i>time & date</i>
5700	installation config.		<i>configuration</i>
Heating circuit No. 1 if 2 circuits = the least warm one (e.g.: floor)			
710	comfort setpoint		<i>HC1 adjust.</i>
712	reduced setpoint		<i>HC1 adjust.</i>
720	heating curve slope		<i>HC1 adjust.</i>
741	flow temp setpoint max		<i>HC1 adjust.</i>
750	room influence		<i>HC1 adjust.</i>
790 / 791	optimis. at switch-on / off		<i>HC1 adjust.</i>
834	servomotor travel time		<i>HC1 adjust.</i>
850 / 851	floor drying		<i>HC1 adjust.</i>
Heating circuit No. 2 (with 2nd circuit option) = the warmest one (e.g.: radiators)			
1010	comfort setpoint		<i>HC2 adjust.</i>
1012	reduced setpoint		<i>HC2 adjust.</i>
1020	heating curve slope		<i>HC2 adjust.</i>
1041	flow temp setpoint max		<i>HC2 adjust.</i>
1050	room influence		<i>HC2 adjust.</i>
1090 / 1091	optimis. at switch-on / off		<i>HC2 adjust.</i>
1134	servomotor travel time		<i>HC2 adjust.</i>
1150 / 1151	floor drying		<i>HC2 adjust.</i>
Domestic Hot Water (if DHW kit)			
1610	nominal DHW temp. setpoint		<i>DHW</i>
1612	reduced DWH temp. setpoint		<i>DHW</i>
1620	DHW release		<i>DHW</i>
1640 to 1642	legionella cycle		<i>DHW</i>
5024	DHW switch-on differ.		<i>DHW tank</i>
5030	charging time limitation		<i>DHW tank</i>
5061	heater release		<i>DHW tank</i>

Setting	Description	Set to.	Menus
Boiler backup			
3700	OT.switch-on authoris.		<i>addit. gen.</i>
3705	swith-off delay		<i>addit. gen.</i>
Miscellaneous			
6420	input H33 function	1	<i>configuration</i>
6100	OT sensor correction		<i>configuration</i>
6120	frost protection on/off		<i>configuration</i>
6205	reset settings		<i>configuration</i>
6220	software version		<i>configuration</i>
6711	reset heat pump		<i>error</i>
Cooling			
5711	cooling unit	2 pipes	<i>configuration</i>
Faults (if a fault occurs, press "Info" key)			
No. 10	outdoor sensor		
No. 33	flow temp. sensor		
No. 44	return temp. sensor		
No. 50	DHW temp. sensor		
No. 60	room sensor 1		
No. 65	room sensor 2		
No. 105	maintenance message		
No. 121	HC1 flow T not reached		
No. 122	HC2 flow T not reached		
No. 127	leg. prot. T not reached		
No. 369	external fault (EX3)		
No. 370	outdoor unit connect error		
6711	reset heat pump		<i>error</i>
Heat pump			
2844	switch-off temp max		<i>heat pump</i>
2884	OT auth. to start elec. aux.		<i>heat pump</i>
2920	Pk day clear (EX1) rel / lock		<i>heat pump</i>
Swimming pool (with "swimming pool" kit option)			
2056	generator setpoint		<i>Sw pool</i>
Outdoor unit faults (see page 58)			

7.3 Start-up data sheet

Site		Installer		
Outdoor unit	serial No.	Hydraulic unit	serial No.	
	model		model	
Refrigerant type		Refrigerant charge kg		
Checks		Operating voltage & current on outdoor unit		
Compliance with positioning distances		L/N or L1/N	V	
Condensate evacuation correct		L2/N	V	
Electric connections / connections tightnees		L3/N	V	
No GAS leaks (unit ID No. :)		L/T or L1/T	V	
Installation of refrigeration connection correct (lenght : m)		L2/T	V	
Reading in HEATING operating mode		L3/T	V	
Compressor discharge temperature °C		N/T	V	
Liquid line temperature °C		Icomp	A	
Condensation temperature	HP = bar °C	sub-cooling °C		
Tank water output temperature	°C	ΔT condensation °C		
Tank water input temperature	°C	ΔT secondary °C		
Evaporation temperature	LP = bar °C			
Suction temperature	°C	Overheating °C		
Battery air input temperature	°C	ΔT evaporation °C		
Battery air output temperature	°C	ΔT battery °C		
Hydraulic system of hydraulic unit				
Secondary system	Low temp. heating floor	}	Circulator brand	Type
	LT Radiators			
	fan coils			
Domestic hot water ; tank type				
Estimated water volume of secondary system L				
Options & accessories :				
Power supply for connected electric auxiliary		Room thermostat		
Operation in cooling mode possible		Room thermostat radio		
Location of room sensor correct		Remote control		
Cooling kit		Wireless remote control		
DHW kit		Details		
2 zone kit				
Control settings				
Configuration type				
Essential settings				

8 Instructions for the user

Explain to the user how his installation operates, in particular the functions of the room thermostat and the programs accessible to him from the user interface.

Emphasise that a heated floor has significant inertia and that therefore any adjustments must be made progressively.

Also explain to the user how to check the filling of the heating circuit.

The frost protection works in all modes of operation and has priority over other functions (provided that the heat pump's electrical power supply is not interrupted).

☞ **Warning ! In winter, in case of power failure, the frost protection is no longer assured.**

The water in the tank of the hydraulic module can freeze and cause damage.



Complies with :

- Low voltage directive 2006/95/EC, under standard EN 60335-1.
- Electromagnetic compatibility Directive 2004/108/EC,
- Directive 2006/42/EC Machinery,
- Directive for pressurised equipment 97/23/EC.

This appliance also conforms to:

- Regulation 842/2006 of the European Parliament on certain fluorinated greenhouse gases.
- The standards relating to the product and the testing methods used: Air-conditioners, refrigeration units and heat pumps with compressor driven by electric motor for heating and refrigeration EN 14511-1, 14511-2, 14511-3, and 14511-4.
- To standard XP ENV 12102: Air-conditioners, heat pumps and dehumidifiers with compressor driven by electric motor. Measurement of airborne noise. Determination of acoustic power level.



This appliance is marked with this symbol. This means that electrical and electronic products shall not be mixed with general household waste.

European Community countries(*), Norway, Iceland and Liechtenstein should have a dedicated collection system for these products.

Do not try to dismantle the system yourself as this could have harmful effects on your health and on the environment.

The dismantling and treatment of refrigerant, oil and other parts must be done by a qualified installer in accordance with relevant local and national regulations.

This appliance must be treated at a specialized treatment facility for re-use, recycling and other forms of recovery and shall not be disposed of in the municipal waste stream.

Please contact the installer or local authority for more information.

* subject to the national law of each member state

Date of installation :

Contact of your heating technician or your after-sales service.