

INSTALLATION MANUAL

PART No. 9373328193-03
Wired Remote Controller

Installation by endusers or not qualified persons can cause harm to personal safety, can cause severe damage to building and product, can lead to improper function or reduced lifetime of the equipment.

CONTENTS

1. SAFETY PRECAUTIONS	1
2. MAIN UNIT AND ACCESSORIES	1
3. ELECTRICAL REQUIREMENT	1
4. SELECTING AN INSTALLATION LOCATION	2
5. INSTALLING THE REMOTE CONTROLLER	2
6. SETTING THE REMOTE CONTROLLER	4
7. TEST RUN	8
8. ERROR CODES	8

1. SAFETY PRECAUTIONS

- The "SAFETY PRECAUTIONS" indicated in the manual contain important information pertaining to your safety. Be sure to observe them.
- For details of the operation method, refer to the operating manual.
- Request the user to keep the manual on hand for future use, such as for relocating or repairing the unit.

WARNING This mark indicates procedures which, if improperly performed, might lead to the death or serious injury of the user.

Perform installation work in accordance with the installation manual. Request an authorized service personnel to perform installation work. Do not install this unit by yourself. Improper installation will cause injury, electric shock, fire, etc.

Perform electrical work by an authorized service personnel in accordance with the installation manual and the electrical wiring regulations or implementation regulations of the country. Also do not install this unit by yourself. Improper electric work will cause electric shock or a fire.

In the event of a malfunction (burning smell, etc.), immediately stop operation, turn off the electrical breaker, and consult authorized service personnel.

Do not install the unit in the following areas:

- Do not install the unit near a source of heat, steam, or flammable gas. Otherwise, fire could result.
- Area filled with mineral oil or containing a large amount of splashed oil or steam, such as a kitchen. It will deteriorate plastic parts, causing the parts to fall.
- Area containing equipment that generates electromagnetic interference. It will cause the control system to malfunction, and cause erroneous operation.
- Install the unit in a well-ventilated place avoiding rains and direct sunlight.

Do not operate this unit when your hands are wet. Touching the unit with wet hands will cause an electric shock.

When children can approach the unit or touch the unit, take preventive measures.

Dispose of the packing materials safely. Tear and dispose of the plastic packing bags so that children cannot play with them. There is the danger of suffocation if children play with the original plastic bags.

CAUTION

This mark indicates procedures which, if improperly performed, might possibly result in personal harm to the user, or damage to property.

When detecting the room temperature using the remote controller, please set up the remote controller according to the following conditions. If the remote controller is not well set, the correct room temperature will not be detected, and thus the abnormal conditions like "not cool" or "not heat" will occur even if the air-conditioner is running normally. :

- A location with an average temperature for the room being air conditioned.
- Not directly exposed to the outlet air from the air conditioner.
- Out of direct sunlight.
- Away from the influence of other heat sources.

Do not touch the switches with sharp objects. Doing so will cause injury, trouble, or electric shock.





Do not expose this unit directly to water. Doing so will cause trouble, electric shock, or heating.

Do not set vessels containing a liquid on this unit. Doing so will cause heating, fire, or electric shock.

Do not insert articles into the slit parts of this unit. Doing so will cause trouble, heating, or electric shock.

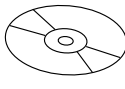
2. MAIN UNIT AND ACCESSORIES

The following installation parts are supplied. Use them as required.

Name and Shape	Q'ty	Name and Shape	Q'ty
 Wired remote controller	1	 CD-ROM	1
 Installation manual (This manual)	1	 Screw (M4 × 16mm) For installing the remote controller	2
 Operating manual	1	 Cable tie For remote controller and remote controller cable binding	1

3. ELECTRICAL REQUIREMENT

When connecting the remote controller use the following wiring.

Cable type	Size	Remarks
Sheathed cable	0.33 to	Non polar 2 core, Twisted pair
Shielded cable*	1.25 mm ²	

* Use shielded cable in accordance with local rules for remote controller cable.

Select a flexible cable that can be bound using cable ties from over the cable sheath inside this unit.

Maximum connectable number of remote controllers by cable size and the length.

Cable size		Max. connectable number of remote controllers		
AWG	mm ²	L* ≤ 100 m	101 m < L* ≤ 250 m	251 m < L* ≤ 500 m
16	1.25	4	4	4
18	0.75 (1.25 > S* ≥ 0.75)	4	4	2
20	0.5 (0.75 > S* ≥ 0.5)	4	2	2
22	0.3 (0.5 > S* ≥ 0.3)	4	1	1

*L: Total cable length, *S: Cable size

English

Deutsch

Français

Español

Italiano

Ελληνικά

Português

Русский

Türkçe

中文

4. SELECTING AN INSTALLATION LOCATION

4. 1. Dimensions and Name of parts

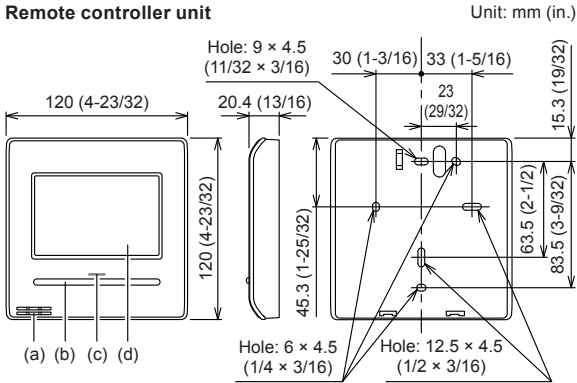

- (a) Room temperature sensor (inside)
 (b) On/Off button:
 It is possible to operate only while displaying the Monitor Mode screen.
 (c) LED lamp (Operation indicator)
 (d) Touch panel display

Monitor mode screen

The home screen of this unit. Except for in the following cases, the screen will go back to the main screen if there is no operation for over 10 min. (Unsaved settings will be cancelled.)

- In Emergency Stop.
- In Transferring data.
- In checking the indoor unit position
- In Function Setting

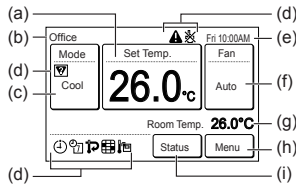

- (a) Set Temp.: Set the operating temperature. Refer to operating manual.
 (b) R.C. Group name: Refer to 6.3.4.
 (c) Mode: Set the operation mode. Refer to operating manual.
 (d) Status icons: Refer to operating manual.
 (e) Clock: Refer to 6.2.4.
 (f) Fan: Set the fan speed. Refer to operating manual.
 (g) Room temperature: Refer to 4.2. and 6.3.5.
 (h) Menu: Set the various settings.
 (i) Status: Check the status of indoor unit and error.

This product uses a Bitmap font made and developed by Ricoh Company, Ltd.

4. 2. SETTING THE ROOM TEMPERATURE DETECTION LOCATION

CAUTION

As the temperature sensor of remote controller detects the temperature near the wall, when there is a certain difference between the room temperature and the wall temperature, the sensor will not detect the room temperature correctly sometimes. Especially when the outer side of the wall on which the sensor is positioned is exposed to the open air, it is recommended to use the temperature sensor of the indoor unit to detect the room temperature when the indoor and outdoor temperature difference is significant.

The detection location of the room temperature can be selected from the following 2 methods. Choose the detection location that is best for the installation location.
 The temperature sensor of the indoor unit or the remote controller can be used to detect the room temperature.

A sensor of the indoor unit (inside)

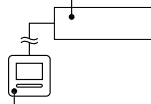

A sensor of the remote controller (inside)

If using the remote control sensor, setting is required. Refer to 6.3.5. RC (Remote Controller) Thermistor Setting.

5. INSTALLING THE REMOTE CONTROLLER

WARNING

Always use the accessories and specified installation work parts. Check the state of the installation parts. Not using the specified parts will cause units to fall off, water leakage, electric shock, fire, etc.

Install at a place that can withstand the weight of the unit and install positively so that the unit will not topple or fall.

When installing this unit, make sure that there are no children nearby. Otherwise, injury or electric shock could result.

Before starting installation work, turn off the power of this unit and the connection destination. Do not turn on the power again until installation is completed. Otherwise, it will cause electric shock or fire.

Use the accessories or specified power supply cable and remote controller cables. Do not modify power supply cable and remote controller cables other than those specified, do not use extension cords, and do not use independent branch wiring. Overcurrent may cause electric shock or fire.

Install the remote controller cables securely to the terminal block. Confirm that external force is not applied to the cable. Use remote controller cables made of the specified wire. If intermediate connection or insertion fixing are imperfect, it will cause electric shock, fire, etc.

When connecting the remote controller cable, route the cables so that the rear case of this unit is securely fixed. If the rear case is imperfectly fixed, it may cause fire or overheating of the terminals.

Perform functional earthing work positively. Do not connect the functional earthing wire to a telephone earth (Ground) wire, water pipe, or conductor rod.

Always fasten the outside covering of the connection cable with the cable tie. If the insulator is chafed, electric discharge may occur.

CAUTION

Do not set the DIP switch or rotary switch of this unit except as specified in this manual or the operating manual supplied with the air conditioner. Setting the switches other than specified will cause an accident or trouble.

Use an insulated screwdriver to set the DIP switches.

Before opening the case of this unit, completely discharge static electricity charged on you body. Not doing so will cause trouble.

Do not touch the circuit board and circuit board parts directly with your hands. Otherwise, injury or electric shock could result.

Do not overtighten the screws. It will cause damage of this unit.

Be careful so that the front case does not fall after the front case screws are removed. Otherwise, injury could result.

Install the remote controller cables 1 m away from television and radio to avoid distorted images and noise.

Confirm the name of each terminal block of the unit and connect the wiring in accordance with the directions given in the manual. Improper wiring work will damage the electric parts and cause smoke and fire.

When installing the connection cable near a source of electromagnetic waves, use shielded cable. Otherwise, a breakdown or malfunction could result.

5. 1. Wiring types

5.1.1. Single control

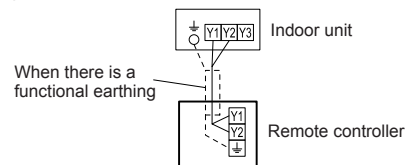

5.1.2. Group control

With a single remote controller, up to 16 units can be simultaneously operated.

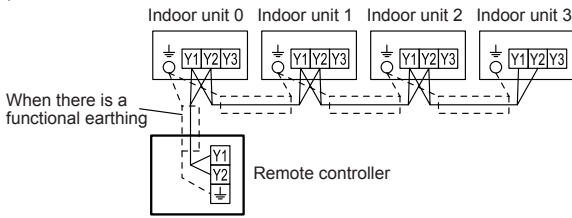

5.1.3. Multiple remote control

Up to 4 remote controllers can be used to operate the indoor units.

Multiple installation method described above is prohibited to combine with UTY-RNK* (3 Wired type) or UTY-RSK* (3 Wired type) or UTY-RHK* (3 Wired type) and UTY-RNR* (2 Wired Type).

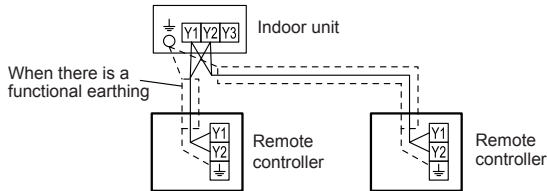

Group control and multiple remote control can be used together.

5.2. Preparing for Installation

5.2.1. Strip of the remote controller cable

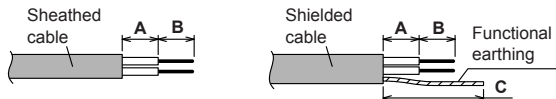

A: 7 mm (9/32 in.), B: 7 mm (9/32 in.), C: 25 mm (31/32 in)

5.2.2. Remove the front case

When open the remote controller, remove the connector from the front case. The cables may break if the connector is not removed and the front case hangs down. When installing the front case, connect the connector to the front case. When removing and connecting the connector, be careful not to break the cables.

Release the claws (2 places) with a flat-blade screwdriver, and separate the front case and rear case.

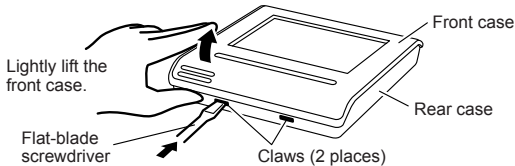

Disconnect the connection cable connector from the connector of the front case PC board (printed circuit board).

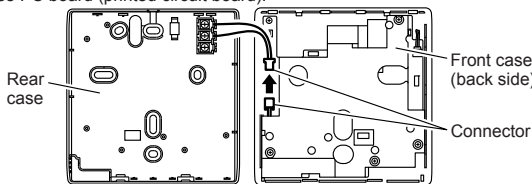

5.2.3. Setting the DIP switch

CAUTION

Use an insulated screwdriver to set the DIP switches. Do not touch the DIP switch with your hands.

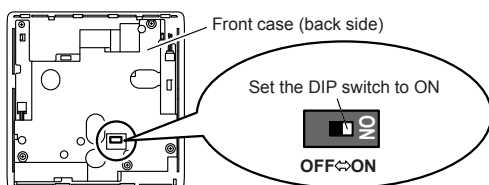

Before using this product, always set DIP switch to "ON". If not set, when the main power is turned on again, the set data by menu operation will be erased and cause erroneous operation.

[DIP Switch]

- Performs the enabling/disabling of the backup function by the internal battery.
- It is disabled when shipped from the factory to prevent consumption of the charge.

5.3. Installation

5.3.1. Install the rear case

A. When mounting on the box:

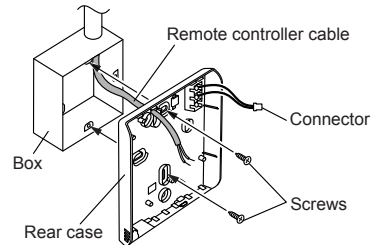

B. When the cable is along the wall:

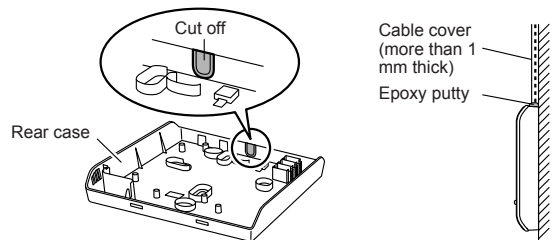

5.3.2. Connecting the remote controller cable

CAUTION

When connecting a remote controller cable to the remote controller terminal block, please use the specified torque to tighten screws. If you over-tighten screws, they will break the terminal unit.

Be careful to avoid breaking the cable by over-tightening the cable tie.

Tightening torque

0.8 to 1.2 N•m (8 to 12 kgf•cm)

Fasten the outside covering of the connection cable with the cable tie. Tighten the cable tie firmly so that pulling force does not propagate to the terminal connection even if force of 30 N is applied to the cable.

Select a flexible cable that can be bound using cable ties from over the cable sheath inside this unit.

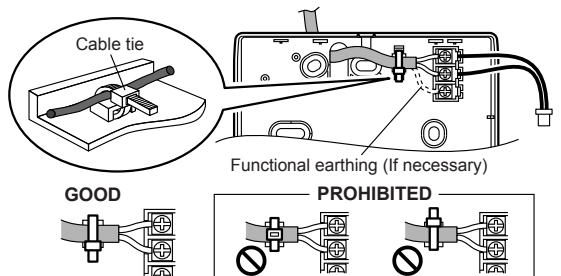

5.3.3. Attach the front case

Connect the connection cable connector to the connector of the front case PC board. Insert after adjusting upper part of front case. Otherwise, there is a risk of damage to the internal parts of this unit. When you attach the front case, make sure that the cables are not being pinched by front case.

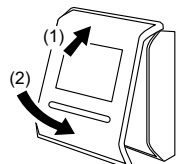

5.4. Connecting to the indoor unit

CAUTION

When connecting the remote controller cable to the indoor unit, do not connect it to the outdoor unit or the power terminal block. It may cause a failure.

When switching the DIP switch (SW1) on the indoor unit PC board, be sure to turn off the power supply to the indoor unit. Otherwise, the PC board of the indoor unit may be damaged.

There are 2 methods to connect the remote controller cable to the indoor unit. One is the connection using connecting cable (Included in the indoor unit), and the other is the connection the remote controller cable is connected to the exclusive terminal block of the indoor unit. (For the details, refer to the installation manual of the indoor unit to be used.)

5.4.1. When connecting to the connector

- Use a tool to cut off the terminal on the end of the remote controller cable, and then remove the insulation from the cut end of the cable as shown in Fig. 1. Connect the remote controller cable and connecting cable as shown in Fig. 2. Be sure to insulate the connection between the cables.

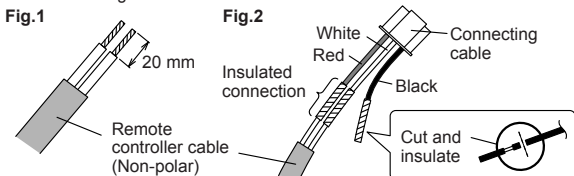

- Connect the remote controller cable to the connecting cable, and insert it to the connector. Set to "2WIRE" the DIP switch (SW1) on the PC board of the indoor unit.

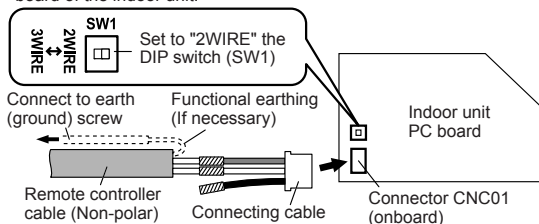

* Layout of Connector and PC board is varies, depending on the type of indoor unit.

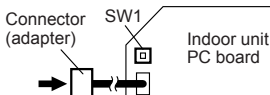

5.4.2 When connecting to exclusive terminal block

- Connect the end of remote controller cable directly to the exclusive terminal block. Set to "2WIRE" the DIP switch (SW1) on the PCB (printed circuit board) of the indoor unit.

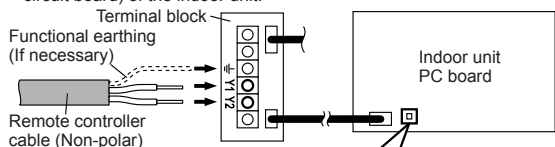

* Layout of terminal block and PC board is varies, depending on the type of indoor unit.

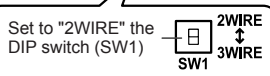

GOOD

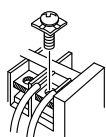

PROHIBITED

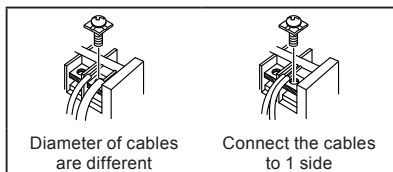

Diameter of cables are different

Connect the cables to 1 side

Tightening torque

M3 screw
(Remote controller / Y1, Y2)

0.5 to 0.6 N·m
(5 to 6 kgf·cm)

6. SETTING THE REMOTE CONTROLLER

6.1. Initialization procedure

After remote controller installation work is complete, perform initialization using the following procedures before starting to use the system.

Turn on the power	6.2.1. Turn on the power..... 4
Setting of first time start	6.2.2. Language Setting..... 4 6.2.3. R.C. Master/Slave Setting..... 5 6.2.4. Date and Time Setting..... 5 6.2.5. Temperature Unit Setting..... 5
Initial setting	6.3.4. R.C. Group Name Setting..... 6 6.3.5. R.C. Sensor Setting..... 6 6.3.6. Master Indoor Unit Setting..... 6 6.3.7. Password Setting (administrator password)... 6 6.3.8. Display Item Setting..... 6
Other Settings	6.4.1. Error History..... 7 6.4.2. Setting Status List..... 7 6.4.3. Filter Sign Reset..... 7 6.4.4. Version..... 7 6.4.5. Test Run..... 7 6.4.6. RC Address Setting..... 7 6.4.7. I.U. Address Verification..... 8 6.4.8. Function Setting..... 8 6.4.9. Installer Password Change..... 8 6.4.10. Initialization..... 8
Initialization end	

After installing this unit, perform the test run to confirm that the unit is operating properly. Then, explain the operation of this unit to the customer.

6.2. Setting of first time start

6.2.1. Turn on the power

CAUTION

Recheck the wiring. Incorrect wiring will cause trouble.

When initially starting up this unit, the following setting screen will be displayed. Settings configured at this stage can be changed afterwards.

If an error screen is displayed, shut down all unit power, and check the connections. After resolving the problem, turn on the power again.

Error Code 01

If "Please set the address correctly." is displayed, touch [Close], and the "RC Address Setting" screen (refer to 6.4.6) will be displayed. After setting, please restart this unit.

Error (code:XX.XX)
Please set the address correctly.
Close

6.2.2. Language Setting

- The "Language Setting" screen has two pages. You can move between the pages by touching [Next Page] or [Previous Page]. Touch the language to be used. Touch [OK] to display the "R.C. Master/ Slave Setting" screen.



6.2.3. R.C. Master/Slave Setting

- (a) If the remote controller is a single connection, this setting is omitted. Proceed to "6.2.4. Date and Time Setting".
- (b) If a remote controller has multiple connections, and if "Master" is initially set, all other units will be set to "Slave".

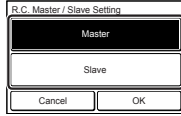

Please set only one Master remote controller. Units other than Master are set to Slave automatically.

When remote controllers are set to "Slave", setting items will be restricted.

Touch [OK] to display the "Date and Time Setting" screen.

6.2.4. Date and Time Setting

- Touch the [Date] on the "Date and Time Setting" screen. The "Date" screen is displayed.
- Touch [▲] or [▼] to set the year, month, and date. Touch [OK] to go back to the "Date and Time Setting" screen.
- Touch the [Time] on the "Date and Time Setting" screen. The "Time" screen is displayed.

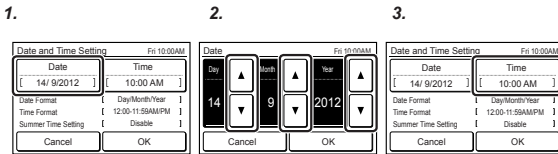

- Touch [▲] or [▼] to set hours, minutes, and AM/PM. Touch [OK] to go back to the "Date and Time Setting" screen.
- Touch [OK] on the "Date and Time Setting" screen to display the "Temperature Unit Setting" screen.

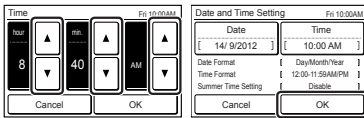

6.2.5. Temperature Unit Setting

- Select and touch [°C] or [°F] and touch [OK].
- When initial start-up setting is complete, the screen on the right will be displayed. This screen is the "Monitor mode screen", which is the home screen of this unit.

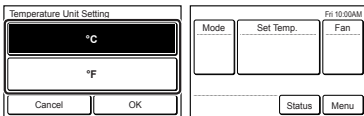

6.3. Initial setting

Configure settings required at the time of installation. For details of the setting, refer to the operating manual on the attached CD-ROM.

This unit has two kinds of passwords; password for administrators and password for installers. Password for administrators cannot be used for the settings related to the installation of this unit. Installer password can be used to configure all of setting for this unit.

When "Password (Installer Password) Verification" screen is displayed, enter the password (installer password) and touch [OK]. The default password is "0000" (4 digits).

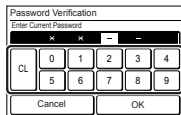

- Touch the [Menu] on the "Monitor Mode screen". The "Main Menu" screen is displayed.
- The "Main Menu" screen has two pages. Touch [Next Page] or [Previous Page] to switch between screens. Touch the [Initial Setting].

-
-

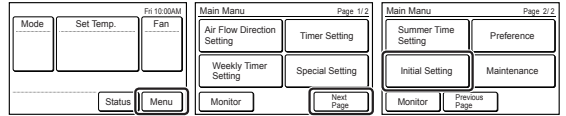

- The "Initial Setting" screen has three pages. Touch [Next Page] or [Previous Page] to switch between screens. Touch the items you wish to configure.

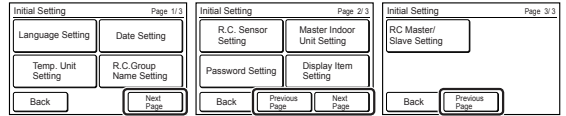

6.3.1. Language Setting

Touch the [Language Setting] on the "Initial Setting" screen. The "Language Setting" screen is displayed.

For the method of setting language, refer to 6.2.2. Language Setting. Select the language to be used, and touch [OK] on "Language Setting" to go back to the "Initial Setting" screen.

6.3.2. Date Setting

- Touch the [Date Setting] on the "Initial Setting" screen. The "Date Setting" screen is displayed. Select and touch "Date and Time Setting" or "Display Format Setting".

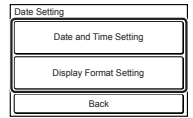

When settings for all items are complete, the screen will return to the home screen. touch [Back] to return to the "Initial Setting" screen.

• Date and Time Setting

Touch the [Date and Time Setting] on the "Date Setting" screen. The "Date and Time Setting" screen is displayed.

For the method of configuration, refer to 6.2.4. Date and Time Setting. Set all required items, and touch [OK] on the "Date and Time Setting" screen to return to the "Initial Setting" screen.

• Display Format Setting

- Touch the [Date Format] on the "Display Format Setting" screen. The "Date Format" screen is displayed.
- Select and touch the data display format. Touch [OK] on the "Date Format" screen to return to the "Display Format Setting" screen.
- Touch the [Time Format] on the "Display Format Setting" screen. The "Time Format" screen is displayed.

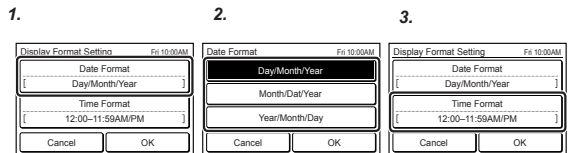

- Select and touch the data display format. Touch [OK] on the "Time Format" to return to the "Display Format Setting" screen.
- Touch [OK] on the "Display Format Setting" screen to return to the "Date Setting" screen.

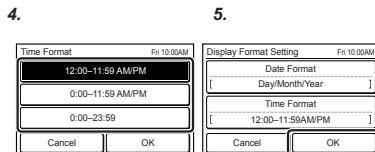

6.3.3. Temperature Unit Setting

Touch the [Temperature Unit Setting] on the "Initial Setting" screen. The "Temperature Unit Setting" screen is displayed.

For how to configure, refer to 6.2.5. Temperature Unit Setting. Set temperature units and touch [OK] on the "Temperature Unit Setting" to return to the "Initial Setting" screen.

6.3.4. R.C. Group Name Setting

Touch the [R.C. Group Name Setting] on the "Initial Setting" screen. The "R.C. Group Name Setting" screen is displayed.

• About the "R.C. Group Name Setting" screen

Touch the relevant key and enter a name. Touch [OK] to return to the (a) R.C. Group Name Setting ABCDEFGHIJKL | Over Cancel OK

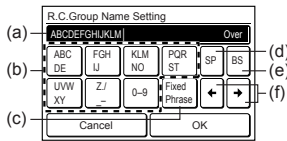

- (a) Input area: If the number of input characters exceeds that permitted, "Over" will be displayed on the right side.
- (b) Character keys: Touch the same key until the character you wish to use is displayed.
- (c) Fixed Phrase key: Floor, Corridor, Office, Conf Room, Recept Room, Room, Room No., Front, Side, Entrance, Outlet, East, West, South, North, Window are registered. Touch the [Fixed Phrase] key until the sentence you wish to use is displayed.
- (d) Space key
- (e) Backspace key
- (f) Cursor keys

6.3.5. RC Sensor Setting

1. Touch the [RC Sensor Setting] on the "Initial Setting" screen. The "RC Sensor Setting" screen is displayed. If a remote-control sensor is used, touch [Used]. Touch [OK] to return to the "Initial Setting" screen.

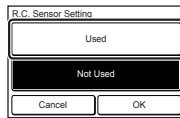

6.3.6. Master Indoor Unit Setting

- One of the multiple indoor units connected to the same refrigerant system or RB unit can be set as the "master unit".
- The indoor unit defined as the "master unit" determines the priority mode (cool or heat) within the refrigerant system or RB group.
- Switch setting on the outdoor unit or RB unit that is connected to the indoor units. Refer to the installation manual of outdoor unit or RB unit.

1. Touch the [Master Indoor Unit Setting] on the "Initial Setting" screen. The "Master Indoor Unit Setting" screen is displayed. To set a unit as the Master Indoor Unit, touch [Set].
2. Touch [Yes] when the confirmation screen is displayed to return to the "Master Indoor Unit Setting" screen.

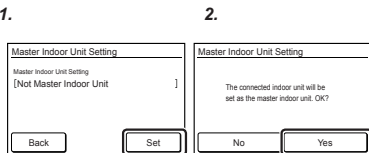

When changing the Master Indoor Unit, another indoor unit cannot be made the master indoor unit unless the settings of the current master indoor unit are changed beforehand. ("Reset" cannot be performed while the indoor unit is operating.)

6.3.7. Password Setting (administrator password)

Set or change the administrator password.

1. Touch the [Password Setting] on the "Initial Setting" screen. The "Password Setting" screen is displayed. Then touch the [Change Password] on the "Password Setting" screen. The "Change Password" screen is displayed.
2. Enter the current password, then touch the [OK]. The default password is "0000" (4 digits).
3. Enter the new password, then touch the [OK]. It returns to the "Password Setting" screen.

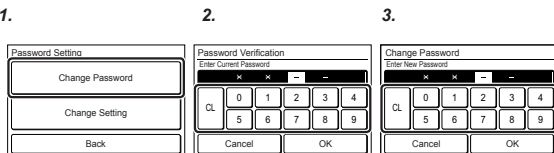

4. Touch the [Change Setting] on the "Password Setting" screen. The "Change Setting" screen is displayed.

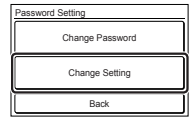

5. The "Change Setting" screen is 3 pages, it can be changed by the [Previous Page] or [Next Page]. Items set to be [ON] require the administrator password to open the setting screen.

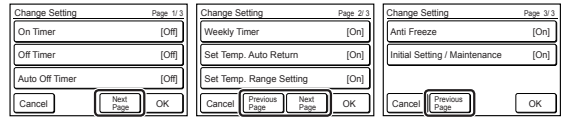

6. Touch the relevant item to display the setting screen. Touch [OK] after touching [ON] to return to the "Change Setting" screen.

Touch [OK] on the "Change Setting" screen after setting relevant items to return to the password setting screen.

7. Touch the [Back] on the "Password Setting". It returns to the "Initial Setting" screen.

- 6.
- 7.

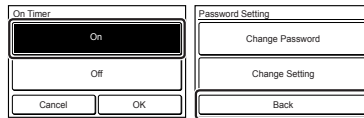

6.3.8. Display Item Setting

• Filter Sign

Set to "Visible" to display icons on the "Monitor mode screen" during the indoor unit filter cleaning period.

1. Touch the [Display Item Setting] on the "Initial Setting" screen. The "Display Item Setting" screen is displayed. Then touch the [Filter Sign] on the "Display Item Setting" screen. The "Filter Sign" screen is displayed.

2. Touch [OK] after touching [Visible] or [Invisible] to return to the "Display Item Setting" screen.

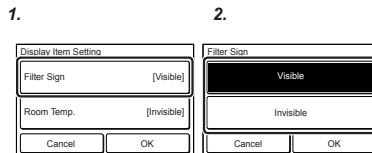

• Room Temperature

Set to "Visible" to display the room temperature detected by this unit on the monitor screen.

3. Touch the [Room Temperature] on the "Display Item Setting" screen. The "Room Temperature" screen is displayed.
4. Touch [OK] after touching [Visible] or [Invisible] to return to the "Display Item Setting" screen.
5. Touch the [OK] on the "Display Item Setting". It returns to the "Initial Setting" screen.

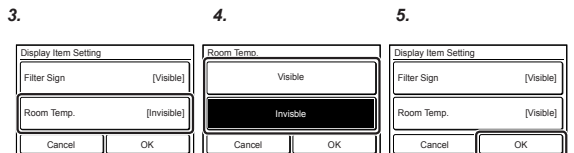

6.3.9. RC Master/Slave Setting

If multiple remote controllers are set for a remote-control group or for a single indoor unit, it is necessary to set the remote-controller master. This setting will be required at the time of initial start-up during installation. However, this setting can be changed afterwards. No master remote controllers will be automatically set to be slaves. The following functions can be used with slave remote controllers. For the method of configuration, refer to 6.2.3. *RC Master Slave Setting*. Setting. Touch [OK] on the "RC Master/Slave Setting" screen after setting the temperature units to return to the "Initial setting" screen.

Do not perform "RC Master/Slave Setting" during setting or operating from the Master unit.

6.4. Maintenance (Other Settings)

Carry out the following setting and confirmation, as required.

1. Touch the [Menu] on the "Monitor mode screen". The "Main Menu" screen is displayed.
2. The "Main Menu" screen has two pages. Touch [Next Page] or [Previous Page] to switch between screens. Then touch the [Maintenance]

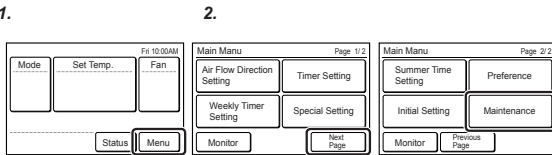

3. The "Maintenance" screen is displayed. The "Maintenance" screen has 3 pages. Touch [Next Page] or [Previous Page] to switch between screens.

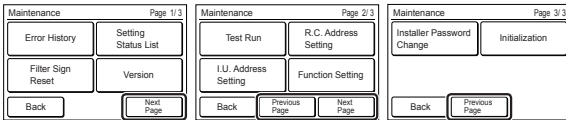

6.4.1 Error History

1. Touch the [Error History] on the "Maintenance" screen. The "Error History" screen is displayed. If there are 7 or more errors, you can switch between pages by touching [Next Page] or [Previous Page] Up to a maximum of 32 errors can be saved. Once there are more than 32 errors, the oldest one will be deleted. Touch [Back] to return to the "Maintenance" screen.
2. To delete the error history, touch [Erase All] and then [Yes] on the confirmation screen.

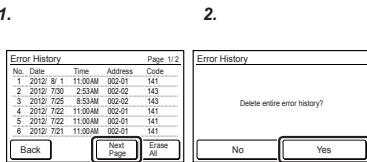

6.4.2. Setting Status List

1. Touch the [Setting Status List] on the "Maintenance" screen. The "Setting Status List" screen is displayed. Touch [Next Page] or [Previous Page] to switch between screens. Touch [Back] to return to the "Maintenance" screen.

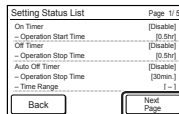

6.4.3. Filter Sign Reset

1. Touch the [Filter Sign Reset] on the "Maintenance" screen. The "Filter Sign Reset" screen is displayed. Touch [OK] to reset the filter sign, and return to the Maintenance screen.



6.4.4. Version

1. Touch the [Version] on the "Maintenance" screen. The "Version" screen is displayed. Touch [Back] to return to the "Maintenance" screen.

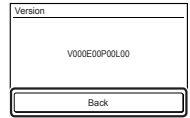

6.4.5. Test Run

Carry out a test run after completing configuration.

1. Touch the [Test Run] on the "Maintenance" screen. The "Test Run" screen is displayed. Touch [OK] to return to the Maintenance screen, and start a test run. The test run will automatically end in approximately 60 min.

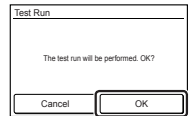

If you wish to cancel the test run before it is complete, return to the "Monitor Mode screen", and touch the On/Off button.

6.4.6. R.C. Address Setting

Addresses will be automatically set when initially starting up this unit. In such a case, do not change the remote-control address for the indoor unit, and keep it at the initial setting of 0.

• Checking the remote controller address

1. Touch the [R.C. Address Setting] on the "Maintenance" screen. The "R.C. Address Setting" screen is displayed. The "Current Address" is displayed as [System-Unit]. The value for "Unit" refers to the remote-control address.

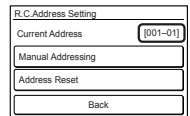

Touch [Back] to return to the "Maintenance" screen.

When the address is set manually, this mark is displayed. * [001-01]

• Manual Address Setting

Only set addresses manually when using different numbers for addresses. A remote-controller address for the indoor unit needs to be set. Set the remote-control addresses for the indoor units which are connected using the same remote-control cable with a range from 1 to 9 and from A (10) to F(15), without any duplicates. (Do not use "0" for configuration.) For how to configure the remote control addresses for the indoor unit, refer to its work manual.

1. Touch the [RC Address Setting] on the "Maintenance" screen. The "R.C. Address Setting" screen is displayed. Touch the [Manual Addressing]. The "Manual Addressing" screen is displayed.
2. Touch [▲] or [▼] to set the addresses of this unit. Touch [OK] to display the confirmation screen, and touch [Yes] to return to the RC Address setting screen. If you wish to carry out configuration again, touch [Address Reset] on the "R.C. Address Setting".

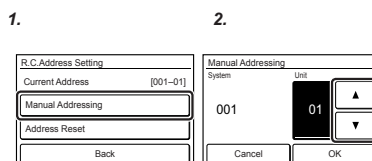

The address for this unit can be set from 1 to 32. However, do not set the same number as that for the remote-control address of an indoor unit connected using the same remote-control cable.

6.4.7. I.U. Address Verification

Check the address and position of the indoor unit.

1. Touch the [I.U. Address Verification] on the "Maintenance" screen. The "I.U. Address Verification" screen is displayed. If there are multiple pages, you can switch between them by touching [Next Page] or [Previous Page]. Touch [Check] to display the indoor unit address checking start screen.
2. Touch [Yes] to display the confirmation screen.
3. Select the indoor unit to be checked. If there are multiple pages, you can switch between them by touching [Next Page] or [Previous Page]. The selected indoor unit will start to blow air and flash a LED*. (*Only when the indoor unit has the relevant functions) Touch [Back] on the confirmation screen to return to the previous screen.

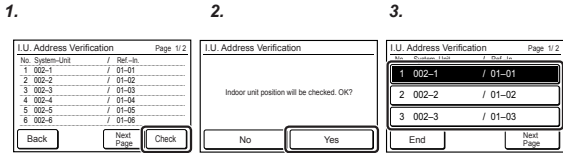

4. Touch [Back] on the "IU Address Verification Screen" to return to the Maintenance Screen.

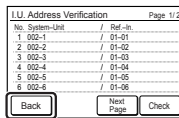

6.4.8. Function Setting

This procedure changes the function settings used to control the indoor unit according to the installation conditions. Incorrect settings can cause the indoor unit to malfunction. Perform the "Function Setting" according to the installation conditions using the remote controller.

- Refer to the indoor unit installation manual for details on the function numbers and setting numbers.
- Prepare for setting of indoor unit referring to installation manual of indoor unit before start of functional setting.

1. Touch the [Function Setting] on the "Maintenance" screen. The "Function Setting" screen is displayed. Touch the [Address] on the "Function Setting" screen. The "Address" screen is displayed.
2. Touch [▲] or [▼] to select the address of the indoor units to be configured. (To set all indoor units at the same time, touch [All].) Touch [OK] to return to the Function Setting screen.
3. Touch the [Function No.] on the "Function Setting" screen. The "Function No." screen is displayed.

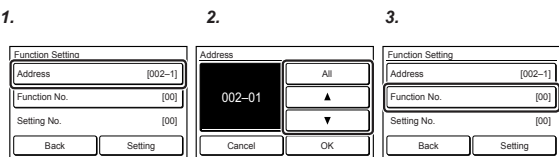

4. Touch [▲] or [▼] to set the function number. Touch [OK] to return to the "Function Setting" screen.
5. Touch the [Setting] on the "Function Setting" screen. The "Setting" screen is displayed.
6. Touch [▲] or [▼] to set the setting number. Touch [OK] to return to the "Function Setting" screen.

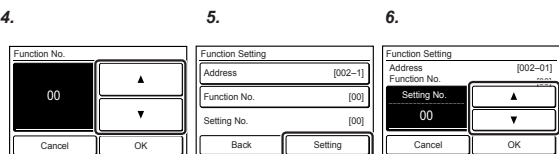

7. Touch [Back] to return to the "Maintenance" screen.

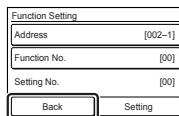

6.4.9. Installer Password Change

Change the Installer password.

1. Touch the [Installer Password Change] on the "Maintenance" screen. The "Installer Password Verification" screen is displayed. Enter the current password, then touch the [OK]. The default password is "0000" (4 digits).
2. The "Installer Password Change" screen is displayed. Enter the new password, then touch the [OK]. It returns to the "Maintenance" screen.

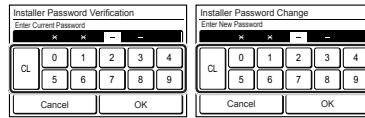

6.4.10. Initialization

Require an Installer password.

1. Touch the [Initialization] on the "Maintenance" screen. Enter the Installer password. The "Initialization" screen is displayed. When the [OK] is touched, this unit restarts automatically after initialization. Perform each setting.

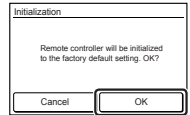

When relocating the set remote controller, initialize it.

7. TEST RUN

- Test run method of the indoor unit is explained.
- Refer to the indoor unit installation manual for the list of items to check.

For how to carry out a test run, refer to 6. 4. Maintenance (Other Settings) → 6.4.5. Test Run.

8. ERROR CODES

Check the error

1. If an error occurred, an error icon appears on the "Monitor mode screen". Touch the [Status] on the "Monitor mode screen". The "Status" screen is displayed.
2. Touch the [Error Information] on the "Status" screen. The "Error Information" screen is displayed. (If there are no errors, the [Error Information] will not be displayed.)
3. 2-digit numbers are corresponding to the error code in the table below. Touch the [Next page] (or [Previous page]) to switch to other unit information.

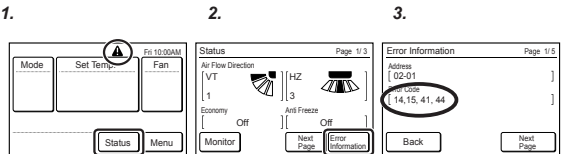

For the details of the indoor unit or outdoor unit error when checking the error contents, refer to the error codes in each installation manual.

Error code	Contents
CC.1	Sensor error
C2.1	Transmission PCB error
12.1	Wired remote controller communication error
12.3	Number excess of device in wired remote controller system
29.2	Connection unit number error (Remote controller)
26.4	Address duplication in wired remote controller system
26.5	Address setting error in wired remote controller system
15.4	Data acquisition error