

# REMOTE CONTROLLER (WIRED TYPE) INSTALLATION MANUAL



PART No. 9373328445

For authorized service personnel only.

[Original instructions]

Installation by endusers or not qualified persons can cause harm to personal safety, can cause severe damage to building and product, can lead to improper function or reduced lifetime of the equipment.

## CONTENTS

1. SAFETY PRECAUTIONS.....	1
2. MAIN UNIT AND ACCESSORIES.....	1
3. ELECTRICAL REQUIREMENT.....	1
4. SELECTING AN INSTALLATION LOCATION.....	2
5. INSTALLING THE REMOTE CONTROLLER.....	2
6. SETTING THE REMOTE CONTROLLER.....	5
7. TEST RUN.....	9
8. ERROR CODES.....	9

## 1. SAFETY PRECAUTIONS

- The "SAFETY PRECAUTIONS" indicated in the manual contain important information pertaining to your safety. Be sure to observe them.
- For details of the operation method, refer to the operating manual.
- Request the user to keep the manual on hand for future use, such as for relocating or repairing the unit.

	<b>WARNING</b>	Indicates a potentially or imminently hazardous situation which, if not avoided, could result in death or serious injury.
Installation of this product must be done by experienced service technicians or professional installers only in accordance with this manual. Installation by nonprofessional or improper installation of the product may cause serious accidents such as injury, water leakage, electric shock, or fire. If the product is installed in disregard of the instructions in this manual, it will void the manufacturer's warranty.		
Installation must be performed in accordance with regulations, codes, or standards for electrical wiring and equipment in each country, region, or the installing place.		
Do not operate this unit when your hands are wet. Touching the unit with wet hands will cause an electric shock.		
When children can approach the unit or touch the unit, take preventive measures.		
Dispose of the packing materials safely. Tear and dispose of the plastic packing bags so that children cannot play with them. There is the danger of suffocation if children play with the original plastic bags.		

	<b>CAUTION</b>	Indicates a potentially hazardous situation that may result in minor or moderate injury or damage to property.
When detecting the room temperature using the remote controller, please set up the remote controller according to the following conditions. If the remote controller is not well set, the correct room temperature will not be detected, and thus the abnormal conditions like "not cool" or "not heat" will occur even if the air-conditioner is running normally. :		
<ul style="list-style-type: none"> <li>• A location with an average temperature for the room being air conditioned.</li> <li>• Locate where is not be affected by inflow of outside air such as caused by opening and closing a door.</li> <li>• Not directly exposed to the outlet air from the air conditioner.</li> <li>• Out of direct sunlight.</li> <li>• Away from the influence of other heat sources.</li> </ul>		

Do not install the unit in the following areas:
<ul style="list-style-type: none"> <li>• Do not install the unit near a source of heat, steam, or flammable gas. Otherwise, fire could result.</li> <li>• Area filled with mineral oil or containing a large amount of splashed oil or steam, such as a kitchen. It will deteriorate plastic parts, causing the parts to fall.</li> <li>• Area containing equipment that generates electromagnetic interference. It will cause the control system to malfunction, and cause erroneous operation.</li> <li>• Install the unit in a well-ventilated place avoiding rains and direct sunlight.</li> </ul>

Do not touch the switches with sharp objects. Doing so will cause injury, trouble, or electric shock.

Do not expose this unit directly to water. Doing so will cause trouble, electric shock, or heating.

Do not set vessels containing a liquid on this unit. Doing so will cause heating, fire, or electric shock.

## 2. MAIN UNIT AND ACCESSORIES

The following installation parts are supplied. Use them as required.

Name and shape	Q'ty	Name and shape	Q'ty
Wired remote controller 	1	CD-ROM 	1
Installation manual (This manual) 	1	Screw (M4 × 16mm) For installing the remote controller 	2
Operating manual 	1	Cable tie For binding remote controller and remote controller cable 	1

## 3. ELECTRICAL REQUIREMENT

When connecting the remote controller use the following wiring.

Cable type	Size	Remarks
Sheathed cable	0.33 to	Non polar 2 core, Twisted pair
Shielded cable*	1.25 mm <sup>2</sup>	

\* Use shielded cable in accordance with local rules for remote controller cable.

Select a flexible cable that can be bound using cable ties from over the cable sheath inside this unit.

Maximum connectable number of remote controllers by cable size and the length.

Cable size		Max. connectable number of remote controllers					
AWG	mm <sup>2</sup>	L* ≤ 100 m		101 m < L* ≤ 250 m		251 m < L* ≤ 500 m	
		VRF	RAC	VRF	RAC	VRF	RAC
16	1.25	4	2	4	2	4	2
18	0.75 (1.25 > S* ≥ 0.75)	4	2	4	2	2	2
20	0.5 (0.75 > S* ≥ 0.5)	4	2	2	2	2	2
22	0.3 (0.5 > S* ≥ 0.3)	4	2	1	1	1	1

\*L: Total cable length, \*S: Cable size

English

Deutsch

Français

Español

Italiano

Ελληνικά

Portugués

Русский

Türkçe

中文

## 4. SELECTING AN INSTALLATION LOCATION

### 4.1. Dimensions and Name of parts

#### Remote controller unit

Unit: mm (in)

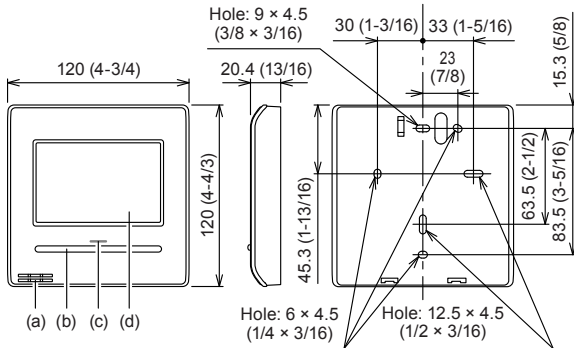

- (a) Room temperature sensor (inside)
- (b) On/Off button:  
It is possible to operate only while displaying the Monitor Mode screen.
- (c) LED lamp (Operation indicator)
- (d) Touch panel display

#### Monitor mode screen

The home screen of this unit. Except for in the following cases, the screen will return to this screen if there is no operation for over 10 min. (Unsaved settings will be cancelled.)

- In Emergency Stop.
- In Transferring data.
- In checking the indoor unit position
- In Function Setting

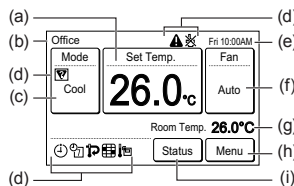

- (a) Set Temp.: Set the operating temperature. Refer to operating manual.
- (b) R.C. Group name: Refer to 6.3.4.
- (c) Mode: Set the operation mode. Refer to operating manual.
- (d) Status icons: Refer to operating manual.
- (e) Clock: Refer to 6.2.4.
- (f) Fan: Set the fan speed. Refer to operating manual.
- (g) Room Temp.: Refer to 4.2. and 6.3.5.
- (h) Menu: Set the various settings.
- (i) Status: Check the status of indoor unit and error.

For the screen display other than Chinese, this product uses a Bitmap font made and developed by Ricoh Company, Ltd.

### 4.2. Setting the room temperature detection location

#### CAUTION

As the temperature sensor of remote controller detects the temperature near the wall, when there is a certain difference between the room temperature and the wall temperature, the sensor will not detect the room temperature correctly sometimes. Especially when the outer side of the wall on which the sensor is positioned is exposed to the open air, it is recommended to use the temperature sensor of the indoor unit to detect the room temperature when the indoor and outdoor temperature difference is significant.

The detection location of the room temperature can be selected from the following 2 methods. The temperature sensor of the indoor unit or the remote controller can be used to detect the room temperature. Choose the detection location that is best for the installation location.

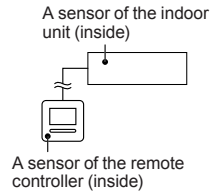

If using the remote control sensor, setting is required. Refer to 6.3.5. RC (Remote Controller) Sensor Setting.

### 4.3. Installation space

- Do not embed this remote controller in a wall.
- Recommendation installation height of the remote controller is 1.4 m (55 in) (from the floor surface to the bottom of the remote controller).
- Even when you install a remote controller to one of a switch box and the surface of a wall, secure the space shown in following figure. When there is insufficient space, there may be remote controller sensor misdetections and remote controller removal may be difficult.

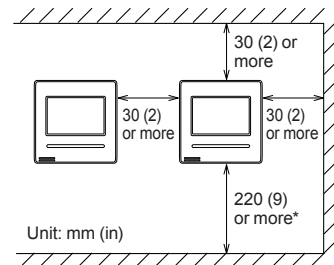

\* Please secure enough space where a flat-blade screwdriver to take off a case can be inserted.

## 5. INSTALLING THE REMOTE CONTROLLER

#### WARNING

Always use the accessories and specified installation work parts. Check the state of the installation parts. Not using the specified parts will cause units to fall off, water leakage, electric shock, fire, etc.

Install at a place that can withstand the weight of the unit and install firmly so that the unit will not topple or fall.

When installing this unit, make sure that there are no children nearby. Otherwise, injury or electric shock could result.

Before starting installation work, turn off the power of this unit and the connection destination. Do not turn on the power again until installation is completed. Otherwise, it will cause electric shock or fire.

Use the accessories or specified connection cables. Do not modify connection cables other than those specified, do not use extension cords, and do not use independent branch wiring. The allowable current will be exceeded and cause electric shock or fire.

Install the remote controller cables securely to the terminal block. Confirm that external force is not applied to the cable. Use remote controller cables made of the specified wire. If intermediate connection or insertion fixing are imperfect, it will cause electric shock, fire, etc.

When connecting the remote controller cable, route the cables so that the rear case of this unit is securely fixed. If the rear case is imperfectly fixed, it may cause fire or overheating of the terminals.

Perform functional earthing work positively. Do not connect the functional earthing wire to a telephone earth (Ground) wire, water pipe, or conductor rod.

Always fasten the cable sheath of the connection cable with the cable tie. If the cable sheath is chafed, electric discharge may occur.

**CAUTION**

Do not set the DIP switch or rotary switch of this unit except as specified in this manual or the operating manual supplied with the air conditioner. Setting the switches other than specified will cause an accident or trouble.

Before opening the case of this unit, completely discharge static electricity charged on you body. Not doing so will cause trouble.

Do not touch the circuit board and circuit board parts directly with your hands. Otherwise, injury or electric shock could result.

Be careful so that the front case does not fall after the front case screws are removed. Otherwise, injury could result.

Install the remote controller cables 1 m away from television and radio to avoid distorted images and noise.

Confirm the name of each terminal block of the unit and connect the wiring in accordance with the directions given in the manual. Improper wiring work will damage the electric parts and cause smoke and fire.

Connect the connectors securely. Loose connectors will cause trouble, heating, fire, or electric shock.

Never bundle the remote controller cables, the power supply cable and transmission cable together. Bundling these cables together will cause miss operation.

When installing the connection cable near a source of electromagnetic waves, use shielded cable. Otherwise, a breakdown or malfunction could result.

**5.1. Wiring types**

**5.1.1. Single control**

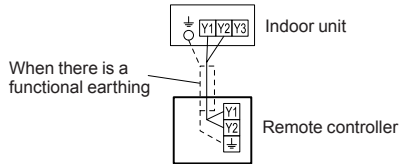

**5.1.2. Group control**

With a single remote controller, up to 16 units can be simultaneously operated.

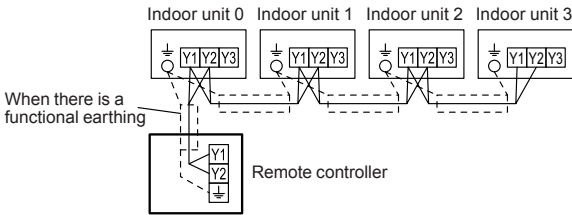

**5.1.3. Multiple remote control**

Number of connectable remote controllers. VRF: 4, RAC: 2

Multiple installation method described above is prohibited to combine 3 Wired type with 2 Wired Type.

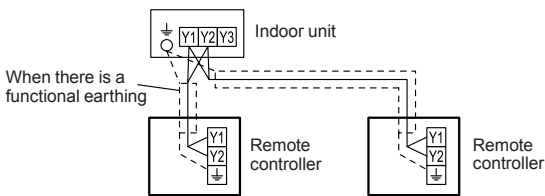

Group control and multiple remote control can be used together.

**5.2. Preparing for Installation**

**5.2.1. Strip of the remote controller cable**

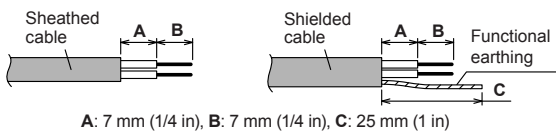

**5.2.2. Remove the front case**

When opening the remote controller, remove the connector from the front case. The cables may break if the connector is not removed and the front case hangs down. When installing the front case, connect the connector to the front case. When removing and connecting the connector, be careful not to break the cables.

Release the claws (2 places) with a flat-blade screwdriver, and separate the front case and rear case.

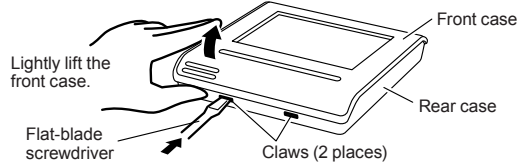

Disconnect the connection cable connector from the connector of the front case PC board (printed circuit board).

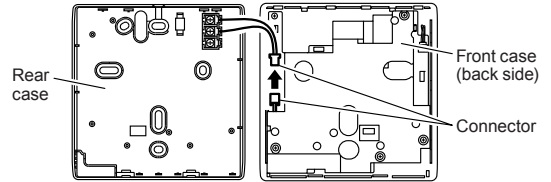

**5.2.3. Setting the DIP switch**

**CAUTION**

Use an insulated screwdriver to set the DIP switches. Do not touch the DIP switch with your hands.

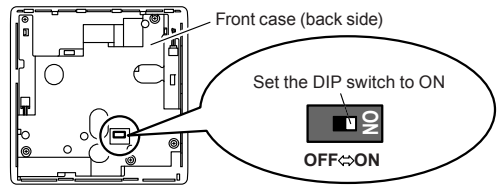

Before using this product, always set DIP switch to "ON". If not set, when the main power is turned on again, the set data by menu operation will be erased and cause erroneous operation.

- [DIP Switch]
- Performs the enabling/disabling of the backup function by the internal battery.
  - It is disabled when shipped from the factory to prevent consumption of the charge.

**5.3. Installation**

**CAUTION**

Perform wiring so that water does not enter this unit along the external wiring. Always install a trap to the wiring or take other countermeasures. Otherwise it will cause trouble or electric shock or fire.

**5.3.1. Install the rear case**

**A. When attaching to switch box:**

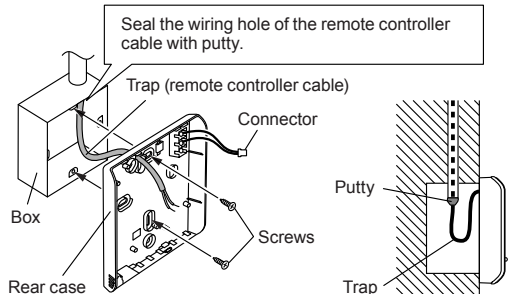

### B. When attaching to the wall directly:

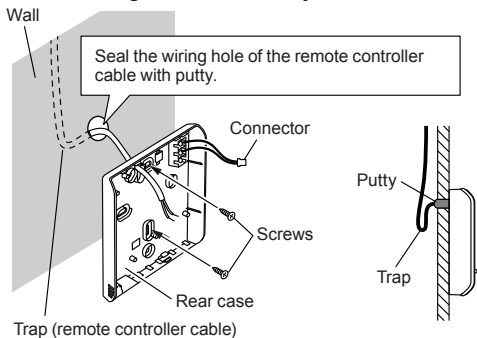

### C. When routing the cable on-wall:

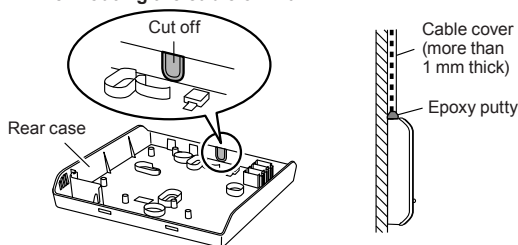

### 5.3.2. Connecting the remote controller cable

#### CAUTION

When connecting a remote controller cable to the remote controller terminal block, please use the specified torque to tighten screws. If you over-tighten screws, they will break the terminal unit.

Be careful to avoid breaking the cable by over-tightening the cable tie.

Tightening torque	0.8 to 1.2 N·m (8 to 12 kgf·cm)
-------------------	---------------------------------

Fasten the outside covering of the connection cable with the cable tie. Tighten the cable tie firmly so that pulling force does not propagate to the terminal connection even if force of 30 N is applied to the cable.

Select a flexible cable that can be bound using cable ties from over the cable sheath inside this unit.

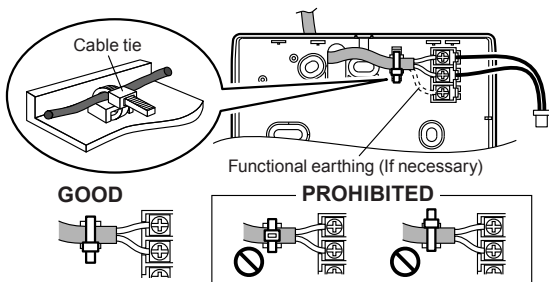

### 5.3.3. Attach the front case

Connect the remote controller cable connector to the connector of the front case PC board. Insert after adjusting upper part of front case. Otherwise, there is a risk of damage to the internal parts of this unit. When you attach the front case, make sure that the cables are not being pinched by front case.

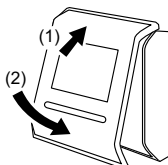

### 5.4. Connecting to the indoor unit

#### CAUTION

When connecting the remote controller cable to the indoor unit, do not connect it to the outdoor unit or the power terminal block. It may cause a failure.

When switching the DIP switch (SW1) on the indoor unit PC board, be sure to turn off the power supply to the indoor unit. Otherwise, the PC board of the indoor unit may be damaged.

There are 2 methods to connect the remote controller cable to the indoor unit. One is the connection using connecting cable (Included in the indoor unit), and the other is the connection the remote controller cable is connected to the exclusive terminal block of the indoor unit. (For the details, refer to the installation manual of the indoor unit to be used.)

#### 5.4.1. When connecting to the connector

- Use a tool to cut off the terminal on the end of the remote controller cable, and then remove the insulation from the cut end of the cable as shown in Fig. 1. Connect the remote controller cable and connecting cable as shown in Fig. 2. Be sure to insulate the connection between the cables.

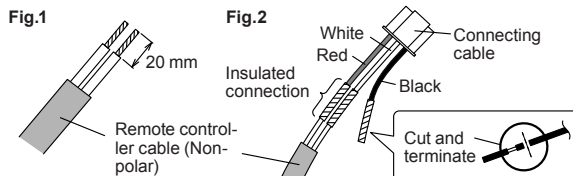

- Connect the remote controller cable to the connecting cable, and insert it to the connector. Set to "2WIRE" the DIP switch (SW1) on the PC board of the indoor unit.

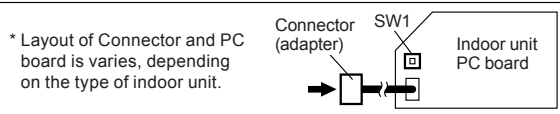
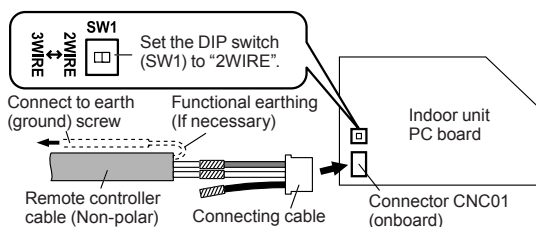

#### 5.4.2. When connecting to exclusive terminal block

- Connect the end of remote controller cable directly to the exclusive terminal block. Set to "2WIRE" the DIP switch (SW1) on the PCB (printed circuit board) of the indoor unit.

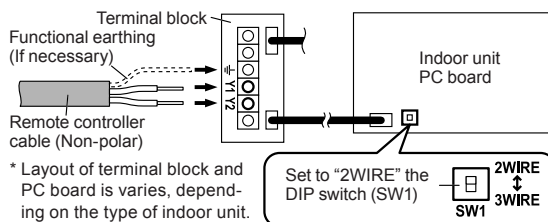

#### Tightening torque

M3 screw	0.5 to 0.6 N·m (5 to 6 kgf·cm)
(Remote controller / Y1, Y2)	

For "Group control" or "Multiple remote control", refer to the following figure on how to connect to the indoor unit terminal.

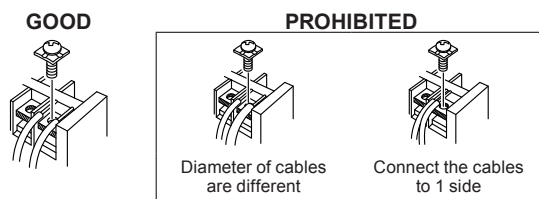

## 6. SETTING THE REMOTE CONTROLLER

### 6.1. Initialization procedure

After remote controller installation work is complete, perform initialization using the following procedures before starting to use the system.  
(\*: Items that indoor unit does not support are not displayed.)

<b>Turn on the power</b>	6.2.1. Turn on the power ..... 5
<b>Setting of first time start</b>	6.2.2. Language Setting ..... 5 6.2.3. R.C. Master/Slave Setting ..... 5 6.2.4. Date and Time Setting ..... 5 6.2.5. Temp. Unit Setting ..... 5 6.2.6. Password Default Setting ..... 5
<b>Initial setting</b>	6.3.4. R.C. Group Name Setting ..... 6 6.3.5. RC Sensor Setting* ..... 6 6.3.6. Master Indoor Unit Setting ..... 6 6.3.7. Password Setting (administrator password) .. 7 6.3.8. Display Item Setting ..... 7 6.3.10. I.U. Display Number Setting* ..... 7
<b>Initialization end</b>	
<b>Other Settings</b>	6.4.1. Error History ..... 8 6.4.2. Setting Status List ..... 8 6.4.3. Filter Sign Reset* ..... 8 6.4.4. Version ..... 8 6.4.5. Test Run ..... 8 6.4.6. R.C. Address Setting ..... 8 6.4.7. I.U. Address Verification ..... 8 6.4.8. Function Setting ..... 9 6.4.9. Installer Password Change ..... 9 6.4.10. Initialization ..... 9

After installing this unit, perform the test run to confirm that the unit is operating properly. Then, explain the operation of this unit to the customer.

### 6.2. Setting of first time start

#### 6.2.1. Turn on the power

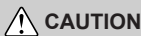

Recheck the wiring. Incorrect wiring will cause trouble.

When initially starting up this unit, the following setting screen will be displayed. Settings configured at this stage can be changed afterwards.

If an error screen is displayed, shut down all unit power, and check the connections. After resolving the problem, turn on the power again.

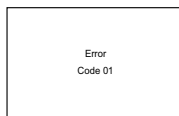

If "Please set the address correctly." is displayed, touch [Close], and the "RC Address Setting" screen (refer to 6.4.6) will be displayed. After setting, please restart this unit.

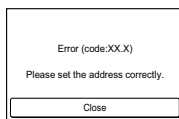

#### 6.2.2. Language Setting

- The "Language Setting" screen has two pages. You can switch between the pages by touching [Next Page] or [Previous Page]. Touch the language to be used.

Touch [OK] to display the "R.C. Master/ Slave Setting" screen.



#### 6.2.3. R.C. Master/Slave Setting

- If the remote controller is a single connection, this setting is omitted. Proceed to "6.2.4. Date and Time Setting".
  - If a remote controller has multiple connections, and if "Master" is initially set, all other units will be set to "Slave".

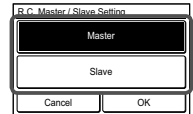

Please set only one Master remote controller. Units other than Master are set to Slave automatically.  
When remote controllers are set to "Slave", setting items will be restricted.

Touch [OK] to display the "Date and Time Setting" screen.

#### 6.2.4. Date and Time Setting

- Touch the [Date] on the "Date and Time Setting" screen. The "Date" screen is displayed.
- Touch [▲] or [▼] to set the year, month, and date. Touch [OK] to return to the "Date and Time Setting" screen.
- Touch the [Time] on the "Date and Time Setting" screen. The "Time" screen is displayed.

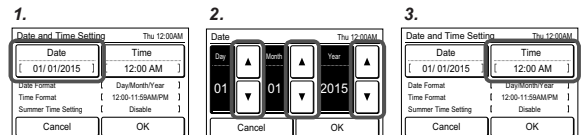

- Touch [▲] or [▼] to set hours, minutes, and AM/PM. Touch [OK] to return to the "Date and Time Setting" screen.
- Touch [OK] on the "Date and Time Setting" screen to display the "Temp. Unit Setting" screen.

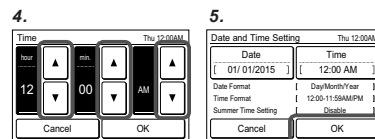

#### 6.2.5. Temp. Unit Setting

- Select and touch [°C] or [°F] and touch [OK].
- Touch [OK] on the "Temp. Unit Setting" screen to display the "Password Default Setting" screen.

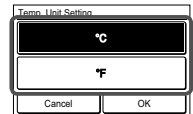

#### 6.2.6. Password Default Setting

- Select and touch [Enable] or [Disable] and touch [OK].  
The initial value at "Change Setting" of "6.3.7 Password Setting" is different depending on the selection of commercial use or residential use. Refer to the table below.

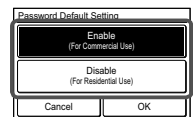

Function (*: Items that indoor unit does not support are not displayed.)	Enable (Commercial)	Disable (Residential)
On Timer	Off	Off
Off Timer	Off	Off
Auto Off Timer	On	Off
Weekly Timer	On	Off
Set Temp. Auto Return	On	Off
Set Temp. Range Setting	On	Off
Anti Freeze*	On	Off
Human Sensor Setting*	On	Off
Fan Control for Energy Saving*	On	Off
Initial Setting	On	Off
Maintenance	On	Off

- When initial start-up setting is complete, the screen on the right will be displayed. This screen is the "Monitor mode screen", which is the home screen of this unit.

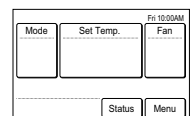

## 6.3. Initial setting

Configure settings required at the time of installation.

This unit has two kinds of passwords; password for administrators and password for installers. Password for administrators cannot be used for the settings related to the installation of this unit. Installer password can be used to configure all of setting for this unit.

When "Password (Installer Password) Verification" screen is displayed, enter the password (installer password) and touch [OK]. The default password is "0000" (4 digits).

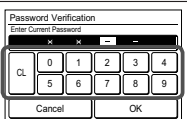

1. Touch the [Menu] on the "Monitor Mode screen". The "Main Menu" screen is displayed.
2. Touch [Next Page] or [Previous Page] to switch between screens. Touch the [Initial Setting].  
(Items that indoor unit does not support are not displayed.)

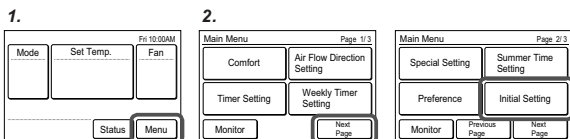

3. Touch [Next Page] or [Previous Page] to switch between screens. Touch the items you wish to configure.  
(Items that indoor unit does not support are not displayed.)

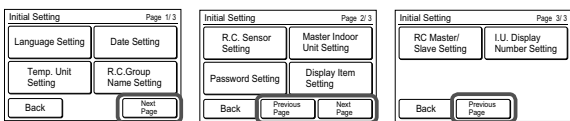

### 6.3.1. Language Setting

Touch the [Language Setting] on the "Initial Setting" screen. The "Language Setting" screen is displayed. For the method of setting language, refer to 6.2.2. Language Setting. Select the language to be used, and touch [OK] on "Language Setting" to return to the "Initial Setting" screen.

### 6.3.2. Date Setting

1. Touch the [Date Setting] on the "Initial Setting" screen. The "Date Setting" screen is displayed. Select and touch "Date and Time Setting" or "Display Format Setting".

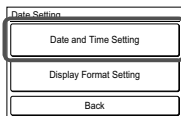

When settings for all items are complete, the screen will return to the home screen. Touch [Back] to return to the "Initial Setting" screen.

### • Date and Time Setting

Touch the [Date and Time Setting] on the "Date Setting" screen. The "Date and Time Setting" screen is displayed. For the method of configuration, refer to 6.2.4. Date and Time Setting. Set all required items, and touch [OK] on the "Date and Time Setting" screen to return to the "Date Setting" screen.

### • Display Format Setting

1. Touch the [Date Format] on the "Display Format Setting" screen. The "Date Format" screen is displayed.
2. Select and touch the data display format. Touch [OK] on the "Date Format" screen to return to the "Display Format Setting" screen.
3. Touch the [Time Format] on the "Display Format Setting" screen. The "Time Format" screen is displayed.

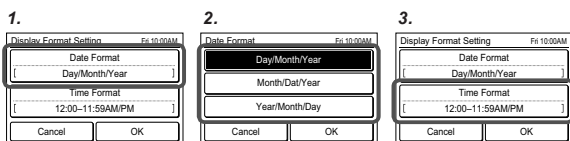

4. Select and touch the data display format. Touch [OK] on the "Time Format" to return to the "Display Format Setting" screen.
5. Touch [OK] on the "Display Format Setting" screen to return to the "Date Setting" screen.

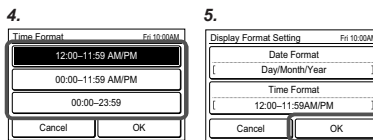

### 6.3.3. Temp. Unit Setting

Touch the [Temp. Unit Setting] on the "Initial Setting" screen. The "Temp. Unit Setting" screen is displayed.

For how to configure, refer to 6.2.5. Temp. Unit Setting. Set temperature units and touch [OK] on the "Temp. Unit Setting" to return to the "Initial Setting" screen.

### 6.3.4. R.C. Group Name Setting

Touch the [R.C. Group Name Setting] on the "Initial Setting" screen. The "R.C. Group Name Setting" screen is displayed.

#### • About the "R.C. Group Name Setting" screen

Touch the relevant key and enter a name. Touch [OK] to return to the "Initial Setting" screen after displaying the "Confirmation screen".

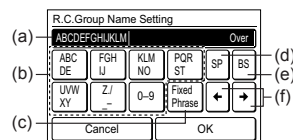

- (a) Input area: If the number of input characters exceeds that permitted, "Over" will be displayed on the right side.
- (b) Character keys: Touch the same key until the character you wish to use is displayed.
- (c) Fixed Phrase key: Floor, Corridor, Office, Conf Room, Recept Room, Room, Room No., Front, Side, Entrance, Outlet, East, West, South, North, Window are registered. Touch the [Fixed Phrase] key until the sentence you wish to use is displayed.
- (d) Space key
- (e) Backspace key
- (f) Cursor keys

### 6.3.5. RC Sensor Setting

1. Touch the [RC Sensor Setting] on the "Initial Setting" screen. The "RC Sensor Setting" screen is displayed. If a remote-control sensor is used, touch [Used]. Touch [OK] to return to the "Initial Setting" screen.

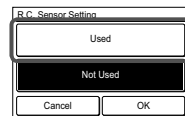

### 6.3.6. Master Indoor Unit Setting

- One of the multiple indoor units connected to the same refrigerant system or RB unit can be set as the "master unit".
- The indoor unit defined as the "master unit" determines the priority mode (cool or heat) within the refrigerant system or RB group.
- Switch setting on the outdoor unit or RB unit that is connected to the indoor units. Refer to the installation manual of outdoor unit or RB unit.

1. Touch the [Master Indoor Unit Setting] on the "Initial Setting" screen. The "Master Indoor Unit Setting" screen is displayed. To set a unit as the Master Indoor Unit, touch [Set].
2. Touch [Yes] when the confirmation screen is displayed to return to the "Master Indoor Unit Setting" screen.

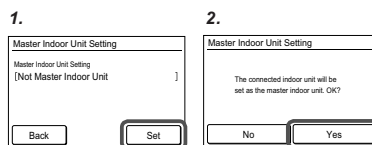

When changing the Master Indoor Unit, another indoor unit cannot be made the master indoor unit unless the settings of the current master indoor unit are cancelled beforehand. ("Reset" cannot be performed while the indoor unit is operating.)

### 6.3.7. Password Setting (administrator password)

Set or change the administrator password.

1. Touch the [Password Setting] on the "Initial Setting" screen. The "Password Setting" screen is displayed. Then touch the [Change Password] on the "Password Setting" screen. The "Change Password" screen is displayed.
2. Enter the current password, then touch the [OK]. The default password is "0000" (4 digits).
3. Enter the new password, then touch the [OK]. It returns to the "Password Setting" screen.

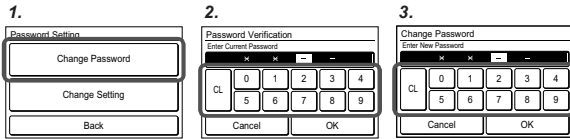

4. Touch the [Change Setting] on the "Password Setting" screen. The "Change Setting" screen is displayed.

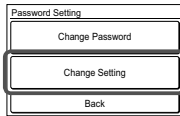

5. The "Change Setting" screen is 3 or 4 pages, they can be switched by the [Previous Page] or [Next Page]. Items set to be [On] require the administrator password to open the setting screen.

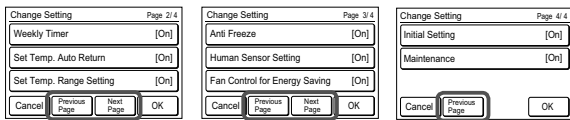

Items that indoor unit does not support are not displayed.

6. Touch the relevant item to display the setting screen. Touch [OK] after touching [On] to return to the "Change Setting" screen. Touch [OK] on the "Change Setting" screen after setting relevant items to return to the password setting screen.
7. Touch the [Back] on the "Password Setting". It returns to the "Initial Setting" screen.

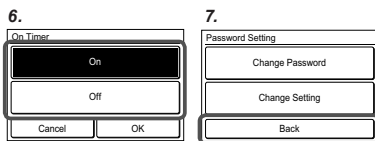

### 6.3.8. Display Item Setting

#### • Filter Sign

Set to "Visible" to display icons on the "Monitor mode screen" during the indoor unit filter cleaning period.

1. Touch the [Display Item Setting] on the "Initial Setting" screen. The "Display Item Setting" screen is displayed. Then touch the [Filter Sign] on the "Display Item Setting" screen. The "Filter Sign" screen is displayed.
2. Touch [OK] after touching [Visible] or [Invisible] to return to the "Display Item Setting" screen.

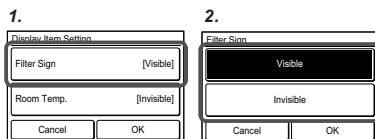

#### • Room Temp.

Set to "Visible" to display the room temperature detected by this unit on the monitor screen.

3. Touch the [Room Temp.] on the "Display Item Setting" screen. The "Room Temp." screen is displayed.
4. Touch [OK] after touching [Visible] or [Invisible] to return to the "Display Item Setting" screen.
5. Touch the [OK] on the "Display Item Setting". It returns to the "Initial Setting" screen.

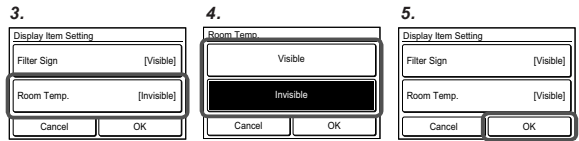

### 6.3.9. RC Master/Slave Setting

If multiple remote controllers are set for a remote-control group or for a single indoor unit, it is necessary to set the remote-controller master. This setting will be required at the time of initial start-up during installation. However, this setting can be changed afterwards. No master remote controllers will be automatically set to be slaves. The following functions can be used with slave remote controllers.

For the method of configuration, refer to 6.2.3. RC Master Slave Setting. Setting. Touch [OK] on the "RC Master/Slave Setting" screen after setting the temperature units to return to the "Initial setting" screen.

Do not perform "RC Master/Slave Setting" during setting or operating from the Master unit.

### 6.3.10. I.U. Display Number Setting

At initial starting, the display numbers (Unit X) of the indoor units displayed at the "Individual VT Hold" setting of this remote controller are automatically allocated in ascending order of address value. (For the indoor unit display number (Unit X), refer to "3-2-3 Individual VT Hold" of the operating manual on the accessory CD-ROM.)

The indoor units (corresponding addresses) can be rearranged in arbitrary order in which you want to correspond to the display number (Unit X) at this setting. Decide the indoor unit (address) corresponding to the display number (Unit X) by consulting the user.

1. Touch the [I.U. Display Number Setting] on the "Initial Setting" screen.
2. "I.U. Display Number Setting" screen is displayed. When the screen has multiple pages, they can be switched by touching the [Next Page] or [Previous Page]. The address (System-Unit) allocated to the current display number (Unit X) is displayed. The refrigeration system address (Ref.-in.) is displayed only when this remote controller is connected to a VRF system. Touch the display numbers (Unit X) whose address you want to interchange.
3. The address selection screen is displayed. Select the address of the indoor unit you want to match to the display number selected at step 2 with [▲] or [▼]. When [OK] is touched, the display returns to the screen of 2 and the address is interchanged with the selected display number (Unit X). Repeat steps 2 and 3 up to the desired order. When [Back] of the screen of 2 is touched, the display returns to the "Initial Setting" screen.

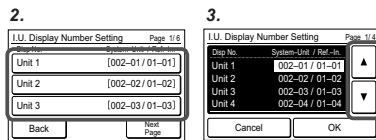

### 6.4. Maintenance (Other Settings)

Carry out the following setting and confirmation, as required.

1. Touch the [Menu] on the "Monitor mode screen". The "Main Menu" screen is displayed.
2. Touch [Next Page] or [Previous Page] to switch between screens. Then touch the [Maintenance]. (Items that indoor unit does not support are not displayed.)

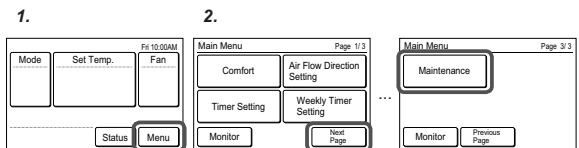

- The "Maintenance" screen is displayed. Touch [Next Page] or [Previous Page] to switch between screens.  
(Items that indoor unit does not support are not displayed.)

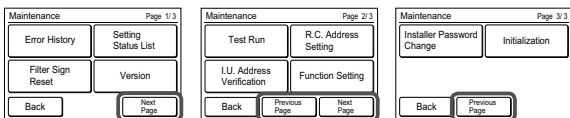

### 6.4.1. Error History

- Touch the [Error History] on the "Maintenance" screen. The "Error History" screen is displayed.  
If there are 7 or more errors, you can switch between pages by touching [Next Page] or [Previous Page]. Up to a maximum of 32 errors can be saved. Once there are more than 32 errors, the oldest one will be deleted.  
Touch [Back] to return to the "Maintenance" screen.
- To delete the error history, touch [Erase All] and then [Yes] on the confirmation screen.

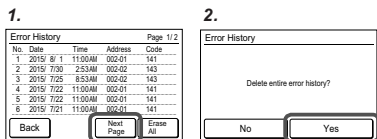

### 6.4.2. Setting Status List

- Touch the [Setting Status List] on the "Maintenance" screen. The "Setting Status List" screen is displayed.  
Touch [Next Page] or [Previous Page] to switch between screens.  
Touch [Back] to return to the "Maintenance" screen.

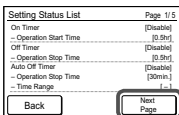

### 6.4.3. Filter Sign Reset

- Touch the [Filter Sign Reset] on the "Maintenance" screen. The "Filter Sign Reset" screen is displayed.  
Touch [OK] to reset the filter sign, and return to the "Maintenance" screen.



### 6.4.4. Version

- Touch the [Version] on the "Maintenance" screen. The "Version" screen is displayed.  
Touch [Back] to return to the "Maintenance" screen.

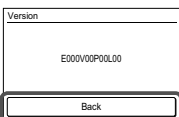

### 6.4.5. Test Run

Carry out a test run after completing configuration.

- Touch the [Test Run] on the "Maintenance" screen. The "Test Run" screen is displayed.  
Touch [OK] to return to the "Maintenance" screen, and start the test run. The test run will automatically end in approximately 60 min.

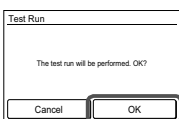

If you wish to cancel the test run before it is complete, return to the "Monitor Mode screen", and touch the On/Off button.

### 6.4.6. R.C. Address Setting

Addresses will be automatically set when initially starting up this unit. In such a case, do not change the remote controller address for the indoor unit, and keep it at the initial setting of 0.

#### • Checking the remote controller address

- Touch the [R.C. Address Setting] on the "Maintenance" screen. The "R.C. Address Setting" screen is displayed.  
The "Current Address" is displayed as [System-Unit]. The value for "Unit" refers to the remote controller address.

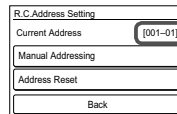

Touch [Back] to return to the "Maintenance" screen.

When the address is set manually, this mark \* is displayed. \* [001-01]

#### • Manual Address Setting

Only set addresses manually when using different numbers for addresses.

A remote-controller address for the indoor unit needs to be set. Set the remote-control addresses for the indoor units which are connected using the same remote-control cable with a range from 1 to 9 and from A (10) to F(15), without any duplicates. (Do not use "0" for configuration.)

For how to configure the remote control addresses for the indoor unit, refer to its installation manual.

- Touch the [RC Address Setting] on the "Maintenance" screen. The "R.C. Address Setting" screen is displayed.  
Touch the [Manual Addressing]. The "Manual Addressing" screen is displayed.
- Touch [▲] or [▼] to set the addresses of this unit. Touch [OK] to display the confirmation screen, and touch [Yes] to return to the RC Address setting screen.  
If you wish to carry out configuration again, touch [Address Reset] on the "R.C. Address Setting".

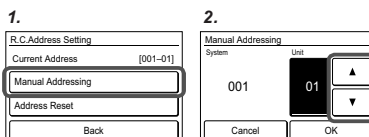

The address for this unit can be set from 1 to 32. However, do not set the same number as that for the remote-control address of an indoor unit connected using the same remote-control cable.

### 6.4.7. I.U. Address Verification

Check the address and position of the indoor unit.

- Touch the [I.U. Address Verification] on the "Maintenance" screen. The "I.U. Address Verification" screen is displayed.  
If there are multiple pages, you can switch between them by touching [Next Page] or [Previous Page].  
Touch [Check] to display the indoor unit address checking start screen.
- Touch [Yes] to display the confirmation screen.
- Select the indoor unit to be checked. If there are multiple pages, you can switch between them by touching [Next Page] or [Previous Page]. The selected indoor unit will start to blow air and flash a LED\*. (\*Only when the indoor unit has the relevant functions)  
Touch [Back] on the confirmation screen to return to the previous screen.

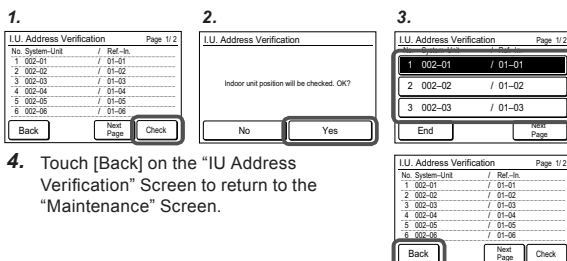



### 6.4.8. Function Setting

This procedure changes the function settings used to control the indoor unit according to the installation conditions. Incorrect settings can cause the indoor unit to malfunction. Perform the "Function Setting" according to the installation conditions using the remote controller.

- Refer to the indoor unit installation manual for details on the function numbers and setting numbers, before the start of function setting.

- Touch the [Function Setting] on the "Maintenance" screen. The "Function Setting" screen is displayed. Touch the [Address] on the "Function Setting" screen. The "Address" screen is displayed.
- Touch [▲] or [▼] to select the address of the indoor units to be configured. (To set all indoor units at the same time, touch [All].) Touch [OK] to return to the Function Setting screen.
- Touch the [Function No.] on the "Function Setting" screen. The "Function No." screen is displayed.

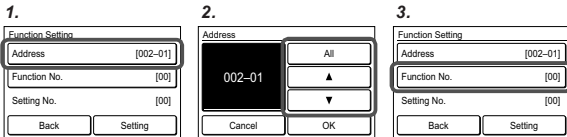

- Touch [▲] or [▼] to set the function number. Touch [OK] to return to the "Function Setting" screen.
- Touch the [Setting No.] on the "Function Setting" screen. The "Setting No." screen is displayed.
- Touch [▲] or [▼] to set the setting number. Touch [OK] to return to the "Function Setting" screen.

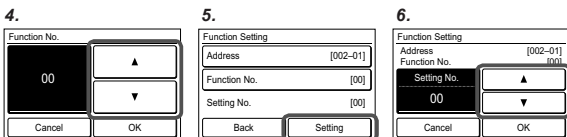

- Touch [Back] to return to the "Maintenance" screen.

### 6.4.9. Installer Password Change

Change the Installer password.

- Touch the [Installer Password Change] on the "Maintenance" screen. The "Installer Password Verification" screen is displayed. Enter the current password, then touch the [OK]. The default password is "0000" (4 digits).
- The "Installer Password Change" screen is displayed. Enter the new password, then touch the [OK]. It returns to the "Maintenance" screen.

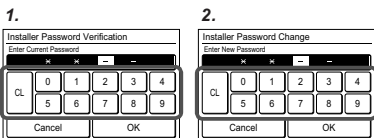

### 6.4.10. Initialization

Require an Installer password.

- Touch the [Initialization] on the "Maintenance" screen. Enter the Installer password. The "Initialization" screen is displayed. When the [OK] is touched, this unit restarts automatically after initialization. Perform each setting.

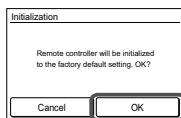

When relocating the set remote controller, initialize it.

## 7. TEST RUN

- Refer to the indoor unit installation manual.

For how to carry out a test run, refer to 6. 4. Maintenance (Other Settings) → 6.4.5. Test Run.

## 8. ERROR CODES

### Check the error

- If an error occurs, an error icon appears on the "Monitor mode screen". Touch the [Status] on the "Monitor mode screen". The "Status" screen is displayed.
- Touch the [Error Information] on the "Status" screen. The "Error Information" screen is displayed. (If there are no errors, the [Error Information] will not be displayed.)
- 2-digit numbers correspond to the error code in the table below. Touch the [Next page] (or [Previous page]) to switch to other connected indoor units.

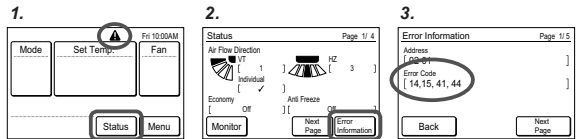

For the details of the indoor unit or outdoor unit error, refer to the error codes in each installation manual.

Error code	Contents
CC.1	Sensor error
C2.1	Transmission PCB error
12.1	Wired remote controller communication error
12.3	Number excess of device in wired remote controller system
12.4	Wired remote controller system start-up error
26.4	Address duplication in wired remote controller system
26.5	Address setting error in wired remote controller system
15.4	Data acquisition error