

- EN INSTRUCTION MANUAL
- ES MANUAL DE INSTRUCCIONES
- DE BEDIENUNGSANLEITUNG
- FR MANUEL D'UTILISATION
- IT MANUALE DI ISTRUZIONI

- PT MANUAL DE INSTRUÇÕES
- DA BRUGSANVISNING
- NL INSTALLATIEHANDLEIDING
- SV INSTALLATIONSHANDBOK
- EL ΕΓΧΕΙΡΙΔΙΟ ΟΔΗΓΙΩΝ

YUTAKI S SERIES RWM-(2.0-10.0)NE

Indoor unit

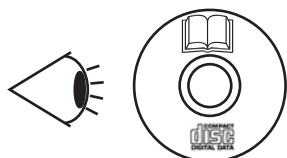

English

Specifications in this manual are subject to change without notice in order that HITACHI may bring the latest innovations to their customers.

Whilst every effort is made to ensure that all specifications are correct, printing errors are beyond HITACHI's control; HITACHI cannot be held responsible for these errors.

Español

Las especificaciones de este manual están sujetas a cambios sin previo aviso a fin de que HITACHI pueda ofrecer las últimas innovaciones a sus clientes.

A pesar de que se hacen todos los esfuerzos posibles para asegurarse de que las especificaciones sean correctas, los errores de impresión están fuera del control de HITACHI, a quien no se hará responsable de ellos.

Deutsch

Bei den technischen Angaben in diesem Handbuch sind Änderungen vorbehalten, damit HITACHI seinen Kunden die jeweils neuesten Innovationen präsentieren kann.

Sämtliche Anstrengungen wurden unternommen, um sicherzustellen, dass alle technischen Informationen ohne Fehler veröffentlicht worden sind. Für Druckfehler kann HITACHI jedoch keine Verantwortung übernehmen, da sie außerhalb ihrer Kontrolle liegen.

Français

Les caractéristiques publiées dans ce manuel peuvent être modifiées sans préavis, HITACHI souhaitant pouvoir toujours offrir à ses clients les dernières innovations.

Bien que tous les efforts sont faits pour assurer l'exactitude des caractéristiques, les erreurs d'impression sont hors du contrôle de HITACHI qui ne pourrait en être tenu responsable.

Italiano

Le specifiche di questo manuale sono soggette a modifica senza preavviso affinché HITACHI possa offrire ai propri clienti le ultime novità.

Sebbene sia stata posta la massima cura nel garantire la correttezza dei dati, HITACHI non è responsabile per eventuali errori di stampa che esulano dal proprio controllo.

Português

As especificações apresentadas neste manual estão sujeitas a alterações sem aviso prévio, de modo a que a HITACHI possa oferecer aos seus clientes, da forma mais expedita possível, as inovações mais recentes.

Apesar de serem feitos todos os esforços para assegurar que todas as especificações apresentadas são correctas, quaisquer erros de impressão estão fora do controlo da HITACHI, que não pode ser responsabilizada por estes erros eventuais.

Dansk

Specifikationerne i denne vejledning kan ændres uden varsel, for at HITACHI kan bringe de nyeste innovationer ud til kunderne.

På trods af alle anstrengelser for at sikre at alle specifikationerne er korrekte, har HITACHI ikke kontrol over trykfejl, og HITACHI kan ikke holdes ansvarlig herfor.

Nederlands

De specificaties in deze handleiding kunnen worden gewijzigd zonder verdere kennisgeving zodat HITACHI zijn klanten kan voorzien van de nieuwste innovaties.

Iedere poging wordt ondernomen om te zorgen dat alle specificaties juist zijn. Voorkomende drukfouten kunnen echter niet door HITACHI worden gecontroleerd, waardoor HITACHI niet aansprakelijk kan worden gesteld voor deze fouten.

Svenska

Specifikationerna i den här handboken kan ändras utan föregående meddelande för att HITACHI ska kunna leverera de senaste innovationerna till kunderna.

Vi på HITACHI gör allt vi kan för att se till att alla specifikationer stämmer, men vi har ingen kontroll över tryckfel och kan därför inte hållas ansvariga för den typen av fel.

Ελληνικά

Οι προδιαγραφές του εγχειριδίου μπορούν να αλλάξουν χωρίς προειδοποίηση, προκειμένου η HITACHI να παρέχει τις τελευταίες καινοτομίες στους πελάτες της.

Αν και έχει γίνει κάθε προσπάθεια προκειμένου να εξασφαλιστεί ότι οι προδιαγραφές είναι σωστές, η HITACHI δεν μπορεί να ελέγξει τα τυπογραφικά λάθη και, ως εκ τούτου, δεν φέρει καμία ευθύνη για αυτά τα λάθη.



CAUTION

This product shall not be mixed with general house waste at the end of its life and it shall be retired according to the appropriated local or national regulations in a environmentally correct way.

Due to the refrigerant, oil and other components contained in heat pump, its dismantling must be done by a professional installer according to the applicable regulations. Contact to the corresponding authorities for more information.

PRECAUCIÓN

Este producto no se debe eliminar con la basura doméstica al final de su vida útil y se debe desechar de manera respetuosa con el medio ambiente de acuerdo con los reglamentos locales o nacionales aplicables.

Debido al refrigerante, el aceite y otros componentes contenidos en la bomba de calor, su desmontaje debe realizarlo un instalador profesional de acuerdo con la normativa aplicable. Para obtener más información, póngase en contacto con las autoridades competentes.

VORSICHT

Dass Ihr Produkt am Ende seiner Betriebsdauer nicht in den allgemeinen Hausmüll geworfen werden darf, sondern entsprechend den geltenden örtlichen und nationalen Bestimmungen auf umweltfreundliche Weise entsorgt werden muss.

Aufgrund des Kältemittels, Öls und anderer Komponenten in der Wärmepumpe muss ihr Ausbau von einem professionellen Installateur entsprechend der anwendbaren Vorschriften durchgeführt werden. Für weitere Informationen setzen Sie sich bitte mit den entsprechenden Behörden in Verbindung.

AVERTISSEMENT

Ne doit pas être mélangé aux ordures ménagères ordinaires à la fin de sa vie utile et qu'il doit être éliminé conformément à la réglementation locale ou nationale, dans le plus strict respect de l'environnement.

En raison du frigorigène, de l'huile et des autres composants que contient la pompe à chaleur, son démontage doit être effectué par un installateur professionnel conformément aux réglementations en vigueur.

AVVERTENZE

Indicazioni per il corretto smaltimento del prodotto ai sensi della Direttiva Europea 2002/96/EC e Dlgs 25 luglio 2005 n.151

Il simbolo del cassonetto barrato riportato sull'apparecchiatura indica che il prodotto alla fine della propria vita utile deve essere raccolto separatamente dagli altri rifiuti.

L'utente dovrà, pertanto, conferire l'apparecchiatura giunta a fine vita agli idonei centri di raccolta differenziata dei rifiuti elettronici ed elettrotecnici, oppure riconsegnarla al rivenditore al momento dell'acquisto di una nuova apparecchiatura di tipo equivalente.

L'adeguata raccolta differenziata delle apparecchiature dismesse, per il loro avvio al riciclaggio, al trattamento ed allo smaltimento ambientalmente compatibile, contribuisce ad evitare possibili effetti negativi sull'ambiente e sulla salute e favorisce il riciclo dei materiali di cui è composta l'apparecchiatura.

Non tentate di smontare il sistema o l'unità da soli poichè ciò potrebbe causare effetti dannosi sulla vostra salute o sull'ambiente.

Vogliate contattare l'installatore, il rivenditore, o le autorità locali per ulteriori informazioni.

Lo smaltimento abusivo del prodotto da parte dell'utente può comportare l'applicazione delle sanzioni amministrative di cui all'articolo 50 e seguenti del D.Lgs. n. 22/1997.

CUIDADO

O seu produto não deve ser misturado com os desperdícios domésticos de carácter geral no final da sua duração e que deve ser eliminado de acordo com os regulamentos locais ou nacionais adequados de uma forma correcta para o meio ambiente.

Por causa do refrigerante, do óleo e de outros componentes na bomba de calor, o desmantelamento deve ser realizado por um instalador profissional em conformidade com os regulamentos aplicáveis. Contacte as autoridades correspondentes para obter mais informações.

ADVASEL!

At produktet ikke må smides ud sammen med almindeligt husholdningsaffald, men skal bortskaffes i overensstemmelse med de gældende lokale eller nationale regler på en miljømæssig korrekt måde.

Da varmepumpen indeholder kølemiddel, olie samt andre komponenter, skal afmontering foretages af en fagmand i overensstemmelse med de gældende bestemmelser. Kontakt de pågældende myndigheder for at få yderligere oplysninger.

VOORZICHTIG

Dit houdt in dat uw product niet wordt gemengd met gewoon huisvuil wanneer u het weg doet en dat het wordt gescheiden op een milieuvriendelijke manier volgens de geldige plaatselijke en landelijke reguleringen.

Wegens de aanwezigheid van koelmiddel, olie en andere componenten in de warmtepomp moet het apparaat volgens de toepasselijke regelgeving door een professionele installateur worden gedemonteerd. Neem contact op met de betreffende overheidsdienst voor meer informatie.

FÖRSIKTIGHET

Det innebär att produkten inte ska slängas tillsammans med vanligt hushållsavfall utan kasseras på ett miljövänligt sätt i enlighet med gällande lokal eller nationell lagstiftning.

Eftersom varmepumpen innehåller kylmedel, oljor och andra komponenter, måste den demonteras av en behörig installatör i enlighet med gällande föreskrifter. Ta kontakt med ansvarig myndighet om du vill ha mer information.

ΠΡΟΣΟΧΗ

Σημαίνει ότι το προϊόν δεν θα πρέπει να αναμιχθεί με τα διάφορα οικιακά απορρίμματα στο τέλος του κύκλου ζωής του και θα πρέπει να αποσυρθεί σύμφωνα με τους κατάλληλους τοπικούς ή εθνικούς κανονισμούς και με τρόπο φιλικό προς το περιβάλλον.

Λόγω του ψυκτικού, του λαδιού και άλλων εξαρτημάτων που περιλαμβάνονται στην αντλία θέρμανσης, η αποσυναρμολόγησή του πρέπει να γίνει από εξουσιοδοτημένο επαγγελματία τεχνικό, σύμφωνα με τους ισχύοντες κανονισμούς. Για περισσότερες λεπτομέρειες, επικοινωνήστε με τις αντίστοιχες αρχές.

<p>MODELS CODIFICATION</p>	<p>Important note: Please, check, according to the model name, which is your heat pump type, how it is abbreviated and referred to in this instruction manual. This Installation and Operation Manual is only related to Indoor Units RWM-NE combined with Outdoor Units RAS-WH(V)NP(E).</p>
<p>CODIFICACIÓN DE MODELOS</p>	<p>Nota importante: compruebe, de acuerdo con el nombre del modelo, el tipo de bomba de calor, su abreviatura y su referencia en el presente manual de instrucciones. Este Manual de instalación y funcionamiento sólo está relacionado con unidades interiores RWM-NE combinadas con unidades externas RAS-WH(V)NP(E).</p>
<p>MODELLCODES</p>	<p>Wichtiger Hinweis: Bitte stellen Sie anhand der Modellbezeichnung den Typ der Wärmepumpe und das entsprechende, in diesem Technischen Handbuch verwendete Kürzel fest. Dieses Installations- und Betriebshandbuch bezieht sich nur auf RWM-NE-Innengeräte in Kombination mit RAS-WH(V)NP(E) Außengeräten.</p>
<p>CODIFICATION DES MODÈLES</p>	<p>Note importante : veuillez déterminer, d'après le nom du modèle, quel est votre type de pompe à chaleur et quelle est son abréviation et référence dans ce manuel d'instruction. Ce manuel d'installation et de fonctionnement ne concernent que les unités intérieures RWM-NE combinées à des groupes extérieurs RAS-WH(V)NP(E).</p>
<p>CODIFICAZIONE DEI MODELLI</p>	<p>Nota importante: controllare in base al modello il tipo di pompa di calore, la descrizione e il tipo di abbreviazione utilizzati nel manuale di istruzioni. Questo manuale di installazione e di funzionamento fa riferimento alla sola combinazione di unità interne RWM-NE e unità esterne RAS-WH(V)NP(E).</p>
<p>CODIFICAÇÃO DE MODELOS</p>	<p>Nota Importante: de acordo com o nome do modelo, verifique o tipo da sua bomba de calor e a respetiva abreviatura e menção neste manual de instruções. Este manual de instalação e de funcionamento só está relacionado com a unidade interior RWM-NE combinada com as unidades exteriores RAS-WH(V)NP(E).</p>
<p>MODELKODIFICERING</p>	<p>Vigtig information: Kontrollér venligst din varmepumpetype i henhold til modelnavnet, hvordan den forkortes, og hvilken reference den har i denne vejledning. Denne bruger- og monteringsvejledning gælder kun RWM-NE-indendørsenheder kombineret med RAS-WH(V)NP(E)-udendørsenheder.</p>
<p>CODERING VAN DE MODELLEN</p>	<p>Belangrijke opmerking: Controleer aan de hand van de modelnaam welk type warmtepomp u heeft, hoe de naam wordt afgekort en hoe ernaar wordt verwezen in deze instructiehandleiding. Deze Installatie- en bedieningshandleiding heeft alleen betrekking op binnenunits RWM-NE gecombineerd met buitenunits RAS-WH(V)NP(E).</p>
<p>MODELLER</p>	<p>Viktigt! Kontrollera med modellnamnet vilken typ av värmepump du har, hur den förkortas och hur den anges i den här handboken. Denna handbok för installation och användning gäller endast för inomhusenheter RWM-NE kombinerade med utomhusenheter RAS-WH(V)NP(E).</p>
<p>ΚΩΔΙΚΟΠΟΙΗΣΗ ΜΟΝΤΕΛΩΝ</p>	<p>Σημαντική σημείωση: Ελέγξτε, σύμφωνα με το όνομα μοντέλου, τον τύπο της δικής σας αντλίας θέρμανσης και με ποια σύντμηση δηλώνεται και αναφέρεται σε αυτό το εγχειρίδιο. Αυτό το εγχειρίδιο εγκατάστασης και λειτουργίας αφορά μόνο τις Εσωτερικές Μονάδες RWM-NE σε συνδυασμό με Εξωτερικές Μονάδες RAS-WH(V)NP(E).</p>

INDOOR UNIT - UNIDAD INTERIOR - INNENGERÄT - UNITÉ INTÉRIEURE - UNITÀ INTERNA - UNIDADE INTERIOR - INDENDØRSENHED - BINNENUNIT - INOMHUSENHET - ΕΣΩΤΕΡΙΚΗ ΜΟΝΑΔΑ

SPLIT AIR TO WATER HEAT PUMP MODELS



1~ 230V 50Hz

3N~ 400V 50Hz

1~ 230V 50Hz		3N~ 400V 50Hz	
Unit	Unit	Unit	Unit
RWM-2.0NE	-	-	-
RWM-2.5NE	-	-	-
RWM-3.0NE	-	-	-
-	RWM-4.0NE	RWM-4.0NE	-
-	RWM-5.0NE	RWM-5.0NE	-
-	RWM-6.0NE	RWM-6.0NE	-
-	-	-	RWM-8.0NE
-	-	-	RWM-10.0NE



i NOTE

Icons between brackets mean possible extra operations to the factory-supplied operations. For cooling operation, refer to the Cooling kit accessory for YUTAKI S units.

i NOTA

Los iconos entre paréntesis representan posibles operaciones adicionales con respecto a las operaciones suministradas de fábrica. Para el funcionamiento en enfriamiento, consulte el accesorio de kit de enfriamiento para unidades YUTAKI S.

i HINWEIS

Die Symbole in Klammern stellen mögliche zusätzliche Betrieben in Bezug auf die gelieferten Fabrikbetrieb. Für den Kühlbetrieb, beziehen Sie sich auf das Cooling Kit Zubehör für YUTAKI S-Einheiten.

i REMARQUE

Les icônes entre parenthèses représentent des opérations supplémentaires possibles en ce qui concerne les opérations fournies. Pour l'opération de refroidissement, reportez-vous à l'accessoire de kit de refroidissement pour les unités Yutaki S.

i NOTA

Icone in parentesi rappresentano possibili operazioni aggiuntive rispetto alle operazioni in dotazione di fabbrica. Per il funzionamento di raffreddamento, fare riferimento al kit di raffreddamento accessorio per unità Yutaki S.

i NOTA

Ícones entre parênteses representam possíveis operações adicionais no que diz respeito às operações fornecidas de fábrica. Para a operação de arrefecimento, consulte o kit de acessório de arrefecimento para unidades Yutaki S.

i BEMÆRK

Ikoner i parentes repræsenterer eventuelle yderligere operationer i forhold til de medfølgende fabrikkens operationer. Para a operação de refrigeração, consulte o resfriamento acessório de kit para unidades Yutaki S.

i OPMERKING

Pictogrammen tussen haakjes betekenen mogelijk extra behandelingsom de fabriek geleverde operaties. Voor koeling, wordt verwezen naar de accessoire kit voor koeling voor Yutaki S units.

i OBS!

Ikoner inom parentes betyder eventuella extra operationer till fabrikslevererad verksamhet. För kyl drift, se Cooling sats tillbehör till Yutaki S-enheter.

i ΣΗΜΕΙΩΣΗ

Εικόνες στις παρενθέσεις αντιπροσωπεύουν πιθανές πρόσθετες λειτουργίες σε σχέση με τις παρεχόμενες εργασίες του εργοστασίου. Για τη λειτουργία ψύξης, ανατρέξτε στο Ψύξη εξάρτημα kit για τις μονάδες YUTAKI S.

INDEX

- 1 GENERAL INFORMATION
- 2 SAFETY
- 3 GENERAL DIMENSIONS
- 4 REFRIGERANT AND WATER PIPING
- 5 ELECTRICAL AND CONTROL SETTINGS
- 6 UNIT INSTALLATION
- 7 COMMISSIONING
- 8 UNIT CONTROLLER

ÍNDICE

- 1 INFORMACIÓN GENERAL
- 2 SEGURIDAD
- 3 DIMENSIONES GENERALES
- 4 TUBERÍAS DE AGUA Y DE REFRIGERANTE
- 5 AJUSTES ELÉCTRICOS Y DE CONTROL
- 6 INSTALACIÓN DE LA UNIDAD
- 7 PUESTA EN MARCHA
- 8 CONTROLADOR DE LA UNIDAD

INHALTSVERZEICHNIS

- 1 ALLGEMEINE INFORMATIONEN
- 2 SICHERHEIT
- 3 ALLGEMEINE ABMESSUNGEN
- 4 KÄLTEMITTEL- UND WASSERLEITUNGEN
- 5 ELEKTRISCHE UND STEUERUNGS-EINSTELLUNGEN
- 6 GERÄTEINSTALLATION
- 7 INBETRIEBNAHME
- 8 GERÄTESTEUERUNG

INDEX

- 1 INFORMATIONS GÉNÉRALES
- 2 SÉCURITÉ
- 3 DIMENSIONS GÉNÉRALES
- 4 TUYAUTERIE FRIGORIFIQUE ET D'EAU
- 5 RÉGLAGES DE COMMANDE ET ÉLECTRIQUES
- 6 INSTALLATION DES UNITÉS
- 7 MISE EN SERVICE
- 8 CONTRÔLEUR D'UNITÉ

INDICE

- 1 INFORMAZIONI GENERALI
- 2 SICUREZZA
- 3 DIMENSIONI GENERALI
- 4 LINEE DELL'ACQUA E DEL REFRIGERANTE
- 5 IMPOSTAZIONI ELETTRICHE E DI CONTROLLO
- 6 INSTALLAZIONE DELL'UNITÀ
- 7 MESSA IN SERVIZIO
- 8 DISPOSITIVO DI CONTROLLO DELL'UNITÀ

ÍNDICE

- 1 INFORMAÇÃO GERAL
- 2 SEGURANÇA
- 3 DIMENSÕES GERAIS
- 4 TUBAGEM DE REFRIGERANTE E DE ÁGUA
- 5 AJUSTES DE CONTROLO E ELÉTRICOS
- 6 INSTALAÇÃO DA UNIDADE
- 7 COLOCAÇÃO EM FUNCIONAMENTO
- 8 CONTROLADOR DA UNIDADE

INDHOLDSFORTEGNELSE

- 1 GENEREL INFORMATION
- 2 SIKKERHED
- 3 GENERELLE MÅL
- 4 KØLEMIDDEL- OG VANDRØR
- 5 ELEKTRISKE OG KONTROLINDSTILLINGER
- 6 MONTERING AF ENHED
- 7 IDRIFTSÆTTELSE
- 8 STYREENHED

INHOUDSOPGAVE

- 1 ALGEMENE INFORMATIE
- 2 VEILIGHEID
- 3 ALGEMENE AFMETINGEN
- 4 KOUEMIDDEL- EN WATERLEIDINGEN
- 5 ELEKTRISCHE EN BESTURINGSINSTELLINGEN
- 6 INSTALLATIE VAN DE UNIT
- 7 INBEDRIJFSTELLING
- 8 BESTURING VAN UNIT

INNEHÅLLSFÖRTECKNING

- 1 ALLMÄN INFORMATION
- 2 SÄKERHET
- 3 ALLMÄNA MÅTT
- 4 KYL- OCH VATTENRÖR
- 5 EL- OCH STYRINNSTÄLLNINGAR
- 6 INSTALLATION AV ENHET
- 7 DRIFTSÄTTNING
- 8 ENHETENS STYRMODUL

ΕΥΡΕΤΗΡΙΟ

- 1 ΓΕΝΙΚΕΣ ΠΛΗΡΟΦΟΡΙΕΣ
- 2 ΑΣΦΑΛΕΙΑ
- 3 ΓΕΝΙΚΕΣ ΔΙΑΣΤΑΣΕΙΣ
- 4 ΨΥΚΤΙΚΟ ΚΑΙ ΣΩΛΗΝΩΣΕΙΣ ΝΕΡΟΥ
- 5 ΡΥΘΜΙΣΕΙΣ ΗΛΕΚΤΡΙΚΕΣ ΚΑΙ ΕΛΕΓΧΟΥ
- 6 ΕΓΚΑΤΑΣΤΑΣΗ ΜΟΝΑΔΩΝ
- 7 ΕΝΑΡΞΗ ΛΕΙΤΟΥΡΓΙΑΣ
- 8 ΧΕΙΡΙΣΤΗΡΙΟ ΜΟΝΑΔΑΣ

EN	English	Original version
ES	Español	Versión traducida
DE	Deutsch	Übersetzte Version
FR	Français	Version traduite
IT	Italiano	Versione tradotta
PT	Português	Versão traduzida
DA	Dansk	Oversat version
NL	Nederlands	Vertaalde versie
SV	Svenska	Översatt version
EL	Ελληνικά	Μεταφρασμένη έκδοση

1 GENERAL INFORMATION

No part of this publication may be reproduced, copied, filed or transmitted in any shape or form without the permission of Johnson Controls-Hitachi Air Conditioning Spain, S.A.U.

Within the policy of continuous improvement of its products, Johnson Controls-Hitachi Air Conditioning Spain, S.A.U. reserves the right to make changes at any time without prior notification and without being compelled to introducing them into products subsequently sold. This document may therefore have

been subject to amendments during the life of the product.

HITACHI makes every effort to offer correct, up-to-date documentation. Despite this, printing errors cannot be controlled by HITACHI and are not its responsibility.

As a result, some of the images or data used to illustrate this document may not refer to specific models. No claims will be accepted based on the data, illustrations and descriptions included in this manual.

2 SAFETY

2.1 APPLIED SYMBOLS

During normal heat pump system design work or unit installation, greater attention must be paid in certain situations requiring particular care in order to avoid injuries and damage to the unit, the installation or the building or property.

Situations that jeopardise the safety of those in the surrounding area or that put the unit itself a risk will be clearly indicated in this manual.

To indicate these situations, a series of special symbols will be used to clearly identify these situations.

Pay close attention to these symbols and to the messages following them, as your safety and that of others depends on it.

DANGER

- *The text following this symbol contains information and instructions relating directly to your safety and physical wellbeing.*
- *Not taking these instructions into account could lead to serious, very serious or even fatal injuries to you and others in the proximities of the unit.*

In the text following the danger symbol you can also find information on safe procedures during unit installation.

CAUTION

- *The text following this symbol contains information and instructions relating directly to your safety and physical wellbeing.*
- *Not taking these instructions into account could lead to minor injuries to you and others in the proximities of the unit.*
- *Not taking these instructions into account could lead to unit damage.*

In the text following the caution symbol you can also find information on safe procedures during unit installation.

NOTE

- *The text following this symbol contains information or instructions that may be of use or that require a more thorough explanation.*
- *Instructions regarding inspections to be made on unit parts or systems may also be included.*

2.2 ADDITIONAL INFORMATION ABOUT SAFETY

DANGER

- **DO NOT CONNECT THE POWER SUPPLY TO THE INDOOR UNIT PRIOR TO FILLING THE SPACE HEATING CIRCUIT (AND DHW CIRCUIT IF IT WERE THE CASE) WITH WATER AND CHECKING WATER PRESSURE AND THE TOTAL ABSENCE OF ANY WATER LEAKAGE.**
- **Do not pour water over the indoor unit electrical parts. If the electrical components are in contact with water a serious electrical shock will take place.**
- **Do not touch or adjust the safety devices inside the air to water heat pump. If these devices are touched or adjusted, a serious accident can take place.**
- **Do not open the service cover or access inside the air to water heat pump without disconnecting the main power supply.**
- **In case of fire Turn OFF the main switch, put out the fire at once and contact your service contractor.**
- **It must ensure that the air to water heat pump cannot operate accidentally without water neither with air inside hydraulic system.**

CAUTION

- *Do not use any sprays such as insecticide, lacquer, hair spray or other flammable gases within approximately one meter from the system.*
- *If installation circuit breaker or the unit fuse is often activated, stop the system and contact your service contractor.*
- *Do not make service or inspections tasks by yourself. This work must be performed by a qualified service person.*
- *This appliance must be used only by adult and capable people, having received the technical information or instructions to handle this appliance properly and safely.*
- *Children should be supervised to ensure that they do not play with the appliance.*
- *Do not let any foreign body into the water inlet and outlet piping of the air to water heat pump.*

2.3 IMPORTANT NOTICE

- The supplementary information about the purchased products is supplied in a CD-ROM, which can be found bundled with the indoor unit. In case that the CD-ROM is missing or it is not readable, please contact your HITACHI dealer or distributor.
- **PLEASE READ THE MANUAL AND THE FILES ON THE CD-ROM CAREFULLY BEFORE STARTING TO WORK ON THE INSTALLATION OF THE AIR TO WATER HEAT PUMP SYSTEM.** Failure to observe the instructions for installation, use and operation described in this documentation may result in operating failure including potentially serious faults, or even the destruction of the air to water heat pump system.
- Verify, in accordance with the manuals which appear in the outdoor and indoor units, that all the information required for the correct installation of the system is included. If this is not the case, contact your distributor.
- HITACHI pursues a policy of continuous improvement in product design and performance. The right is therefore reserved to vary specifications without notice.
- HITACHI cannot anticipate every possible circumstance that might involve a potential hazard.
- This air to water heat pump has been designed for standard water heating for human beings only. Do not use this for other purposes such as for drying clothes, heating foods or for any other heating process (except swimming pool).
- No part of this manual may be reproduced without written permission.
- If you have any questions, contact your service contractor of HITACHI.
- Check and make sure that the explanations of each part of this manual correspond to your air to water heat pump model.
- Refer to the models codification to confirm the main characteristics of your system.
- Signal words (NOTE, DANGER and CAUTION) are used to identify levels of hazard seriousness. Definitions for identifying hazard levels are provided in initial pages of this document.
- The operation modes of these units are controlled by the unit controller.
- This manual should be considered as a permanent part of the air to water heat pump. It gives a common description of and information for this air to water heat pump which you operate as well as for other models.
- Keep the water temperature of the system above the freezing temperature.

3 GENERAL DIMENSIONS

3.1 SERVICE SPACE

◆ RWM-(2.0-10.0)NE

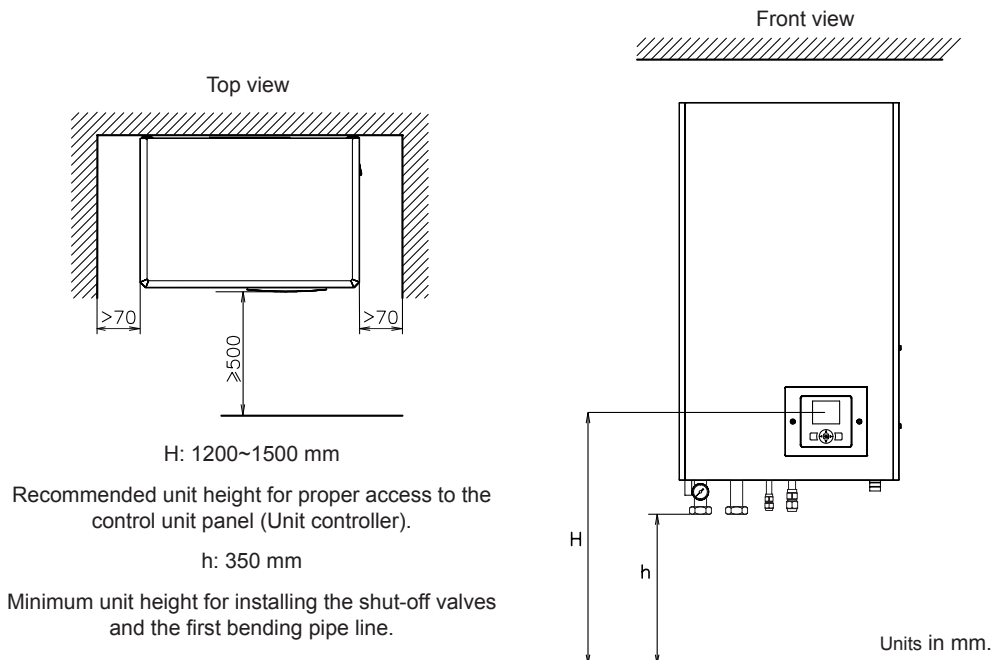

3.2 NAME OF PARTS AND DIMENSIONAL DATA

3.2.1 RWM-(2.0-3.0)NE

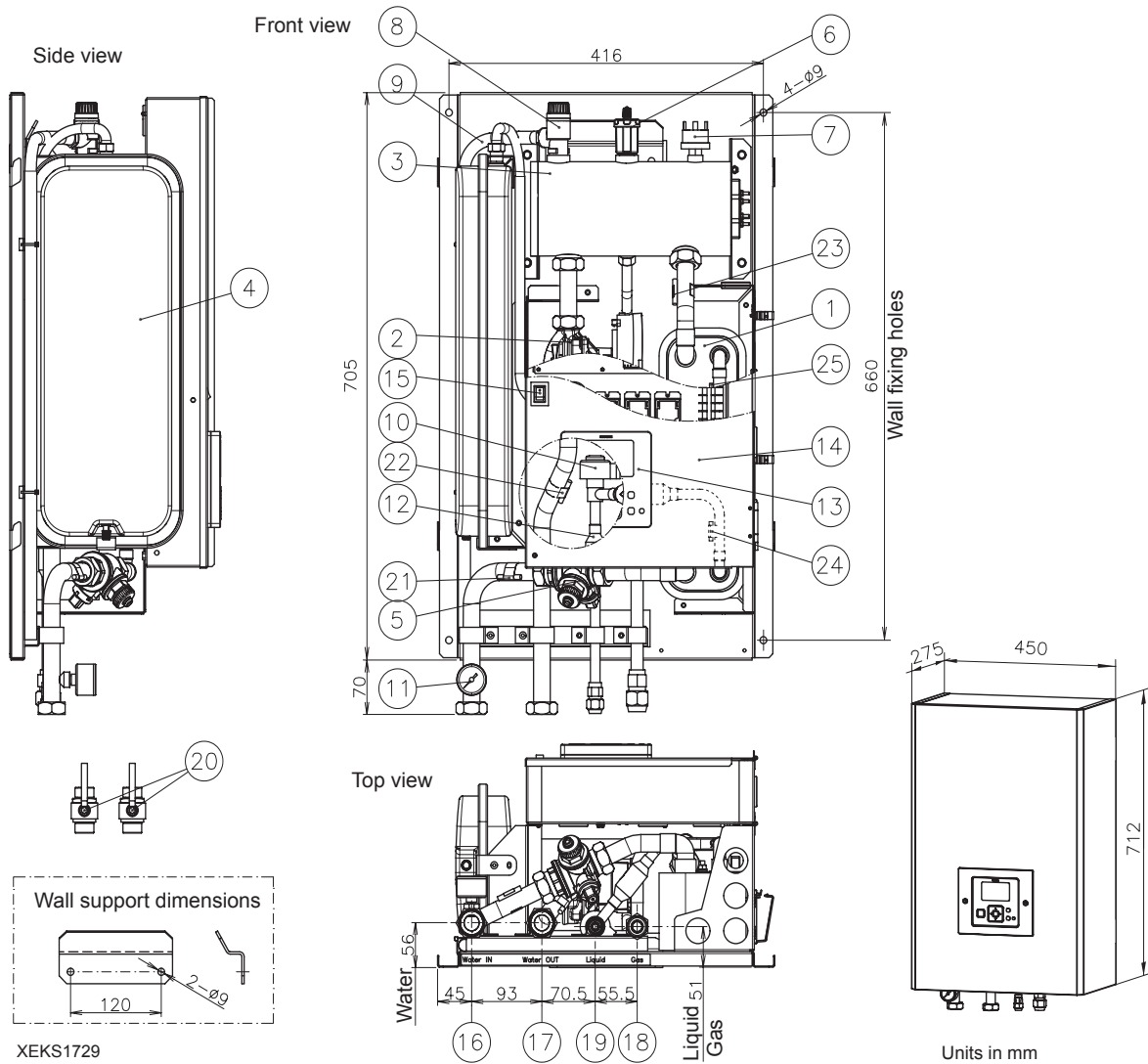

XEKS1729

Number	Part name	Number	Part name
1	Plate heat exchanger	13	Unit controller
2	Water pump	14	Electrical box
3	Electric water heater	15	Switch for DHW emergency operation
4	Expansion vessel 6L	16	Water inlet pipe connection - G 1" Female
5	Water strainer	17	Water outlet pipe connection - G 1" Female
6	Air purger	18	Refrigerant gas pipe connection - \varnothing 15.88 (5/8")
7	Water low pressure switch	19	Refrigerant liquid pipe connection 2.0HP: \varnothing 6.35 (1/4"); 2.5/3.0HP: \varnothing 9.52 (3/8")
8	Safety valve	20	Shut-off valve (Factory-supplied accessory)
9	Drain pipe for safety valve	21	Thermistor (Water inlet pipe)
10	Expansion valve	22	Thermistor (Water outlet pipe)
11	Manometer	23	Thermistor (Water outlet PHEX)
12	Refrigerant strainer (x2)	24	Thermistor (Liquid refrigerant pipe)
		25	Thermistor (Gas refrigerant pipe)

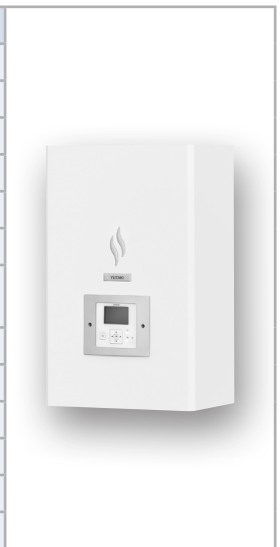

3.2.2 RWM-(4.0-6.0)NE

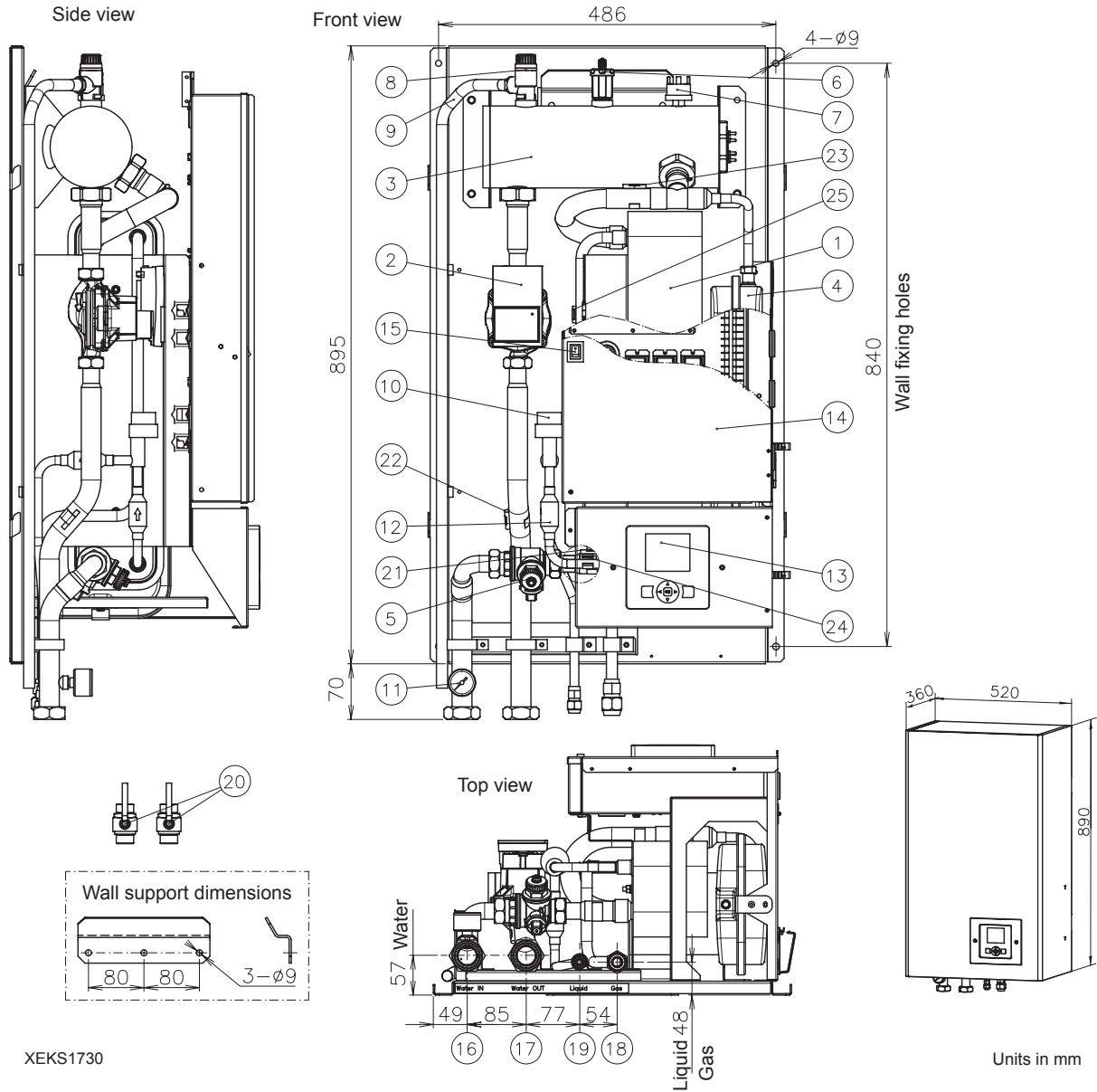

XEKS1730

Units in mm

Number	Part name	Number	Part name
1	Plate heat exchanger	13	Unit controller
2	Water pump	14	Electrical box
3	Electric water heater	15	Switch for DHW emergency operation
4	Expansion vessel 6L	16	Water inlet pipe connection - G 1 1/4" female
5	Water strainer	17	Water outlet pipe connection - G 1 1/4" female
6	Air purger	18	Refrigerant gas pipe connection - Ø 15.88 (5/8")
7	Water low pressure switch	19	Refrigerant liquid pipe connection - Ø 9.52 (3/8")
8	Safety valve	20	Shut-off valve (Factory supplied accessory)
9	Drain pipe for safety valve	21	Thermistor (Water inlet pipe)
10	Expansion valve (x2)	22	Thermistor (Water outlet pipe)
11	Manometer	23	Thermistor (Water outlet PHEX)
12	Refrigerant strainer	24	Thermistor (Liquid refrigerant pipe)
		25	Thermistor (Gas refrigerant pipe)



3.2.3 RWM-(8.0/10.0)NE

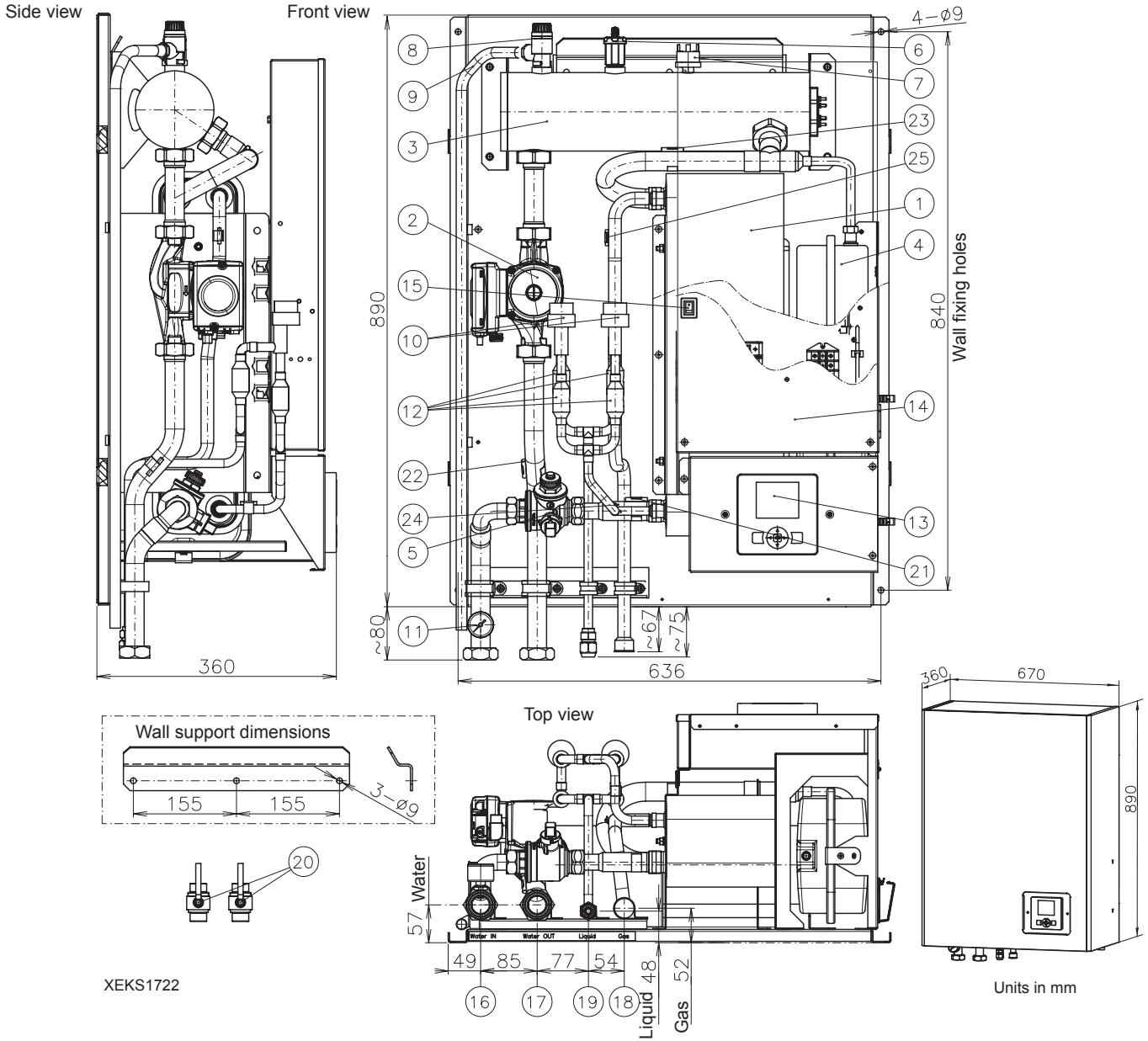

XEKS1722

Units in mm

Number	Part name	Number	Part name
1	Plate heat exchanger	13	Unit controller
2	Water pump	14	Electrical box
3	Electric water heater	15	Switch for DHW emergency operation
4	Expansion vessel 10L	16	Water inlet pipe connection - G 1 1/4" Female
5	Water strainer	17	Water outlet pipe connection - G 1 1/4" Female
6	Air purger	18	Refrigerant gas pipe connection - Ø25.4 (1")
7	Water low pressure switch	19	Refrigerant liquid pipe connection 8HP: Ø9.52 (3/8") 10HP: Ø12.7 (1/2")
8	Safety valve	20	Shut-off valve (factory-supplied accessory)
9	Drain pipe for safety valve	21	Thermistor (Water inlet pipe)
10	Expansion valve (x2)	22	Thermistor (Water outlet pipe)
11	Manometer	23	Thermistor (Water outlet PHEX)
12	Refrigerant strainer (x4)	24	Thermistor (Liquid refrigerant pipe)
		25	Thermistor (Gas refrigerant pipe)



4 REFRIGERANT AND WATER PIPING

4.1 GENERAL NOTES BEFORE PERFORMING PIPING WORK

- Prepare locally-supplied copper pipes.
- Select the piping size with the correct thickness and correct material able to withstand sufficient pressure.
- Select clean copper pipes. Make sure that there is no dust or moisture inside the pipes. Blow the inside of the pipes with oxygen free nitrogen to remove any dust and foreign materials before connecting them.

i NOTE

A system with no moisture or oil contamination will give maximum performance and lifecycle compared to that of a poorly prepared system. Take particular care to ensure that all copper piping is clean and dry internally.

- Cap the end of the pipe when pipe is to be inserted through a wall hole.
- Do not put pipes on the ground directly without a cap or vinyl tape at the end of the pipe.

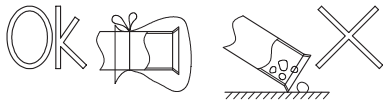

- If piping installation is not completed until next day or over a longer period of time, braze off the ends of the piping and charge with oxygen free nitrogen through a Schrader valve type access fitting to prevent moisture and particle contamination.
- It is advisable to insulate the water pipes, joints and connections in order to avoid heat loss and dew condensation on the surface of the pipes or accidental injuries due to excessive heat on piping surfaces.
- Do not use insulation material that contains NH₃, as it can damage copper pipe material and become a source of future leakage.
- It is recommended to use flexible joints for the water piping inlet and outlet in order to avoid vibration transmission.
- Refrigerant circuit and Water circuit must be performed and inspected by a licensed technician and must comply with all relevant European and national regulations.
- Proper water pipe inspection should be performed after piping work to assure there is no water leakage in the space heating circuit.

4.2 REFRIGERANT CIRCUIT

4.2.1 Refrigerant charge

The R410A refrigerant is factory charged in the outdoor unit with a refrigerant charge amount for 30 m of piping length between outdoor and indoor unit. The maximum refrigerant piping length is 30 m, so additional refrigerant charge is not required.

i NOTE

Refer to the outdoor unit Installation and operation manual to charge the R410A refrigerant inside the indoor unit.

4.2.2 Precautions in the event of gas refrigerant leaks

The installers and those responsible for drafting the specifications are obliged to comply with local safety codes and regulations in the case of refrigerant leakage.

! CAUTION

- Check for refrigerant leakage in detail. If a large refrigerant leakage occurred, it would cause difficulty with breathing or harmful gases would occur if a fire were in the room.
- If the flare nut is tightened too hard, it may crack over time and cause refrigerant leakage.

◆ Maximum permitted concentration of HFCs

The refrigerant R410A (charged in the outdoor unit) is an incombustible and non-toxic gas. However, if leakage occurs and gas fills a room, it may cause suffocation.

The maximum permissible concentration of HFC gas according to EN378-1 is:

Refrigerant	Maximum permissible concentration (kg/m ³)
R410A	0.44

The minimum volume of a closed room where the system is installed to avoid suffocation in case of leakage is:

System combination	Minimum volume (m ³)
2 HP	3.2
2.5 HP	3.5
3 HP	3.9
4 HP	7.5
5/6 HP	7.8
8 HP	11.4
10 HP	12.1

The formula used for the calculation of the maximum allowed refrigerant concentration in case of refrigerant leakage is the following:

R	R: Total quantity of refrigerant charged (kg)
— = C	V: Room volume (m ³)
V	C: Refrigerant concentration

If the room volume is below the minimum value, some effective measure must be taken account after installing to prevent suffocation in case of leakage.

4.3 SPACE HEATING AND DHW

⚠ DANGER

Do not connect the power supply to the indoor unit prior to filling the space heating circuit (and DHW circuit if it were the case) with water and checking water pressure and the total absence of any water leakage.

4.3.1 Additional hydraulic necessary elements for space heating

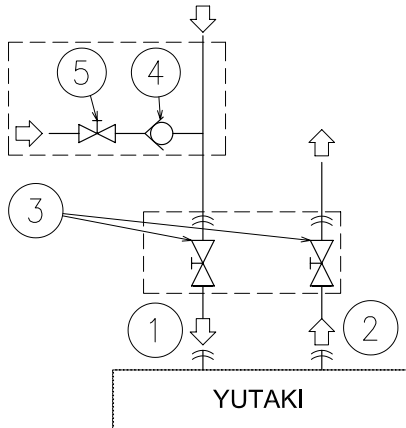

Nature	No.	Part name
Piping connections	1	Water inlet (Space heating)
	2	Water outlet (Space heating)
Factory supplied	3	Shut-off valve (factory-supplied)
Accessories	4	Water check valve (ATW-WCV-01 accessory)
Field supplied	5	Shut-off valve

The following hydraulic elements are necessary to correctly perform the space heating water circuit:

- **Two shut-off valves (factory supplied accessory) (3)** must be installed in the indoor unit. One at the water inlet connection (1) and the other at the water outlet connection (2) in order to make easier any maintenance work.
- **A water check valve (ATW-WCV-01 accessory) (5)** with 1 shut-off valve (field supplied) (4) must be connected to the water filling point when filling the indoor unit. The check valve acts as a safety device to protect the installation against back pressure, back flow and back syphon of non-potable water into drinking water supply net.

4.3.2 Additional hydraulic necessary elements for DHW

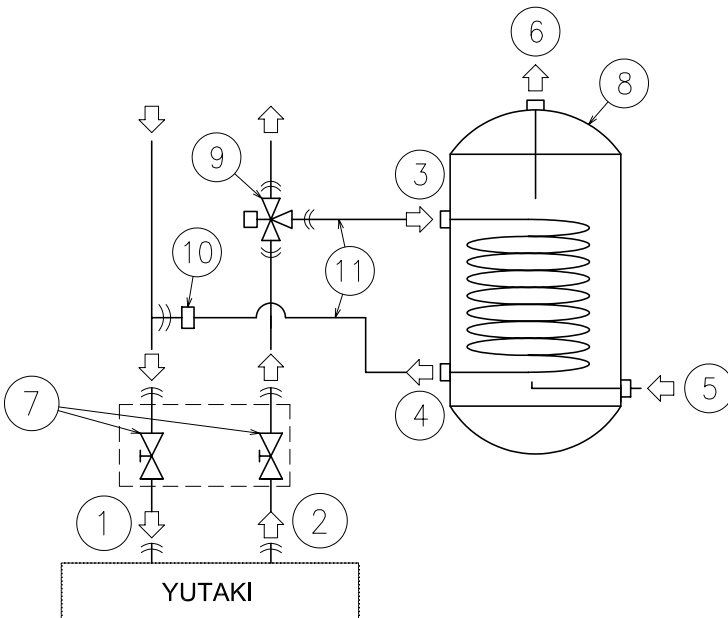

Nature	N°	Part name
Piping connections	1	Water inlet (Space heating)
	2	Water outlet (Space heating)
	3	Heating coil inlet
	4	Heating coil outlet
	5	Water inlet (DHW)
6	Water outlet (DHW)	
Factory supplied	7	Shut-off valve (factory-supplied)
Accessories	8	Domestic hot water tank (DHWT-(200/300)S-3.0H2E accessory)
	9	3-way valve (ATW-3WV-01 accessory)
Field supplied	10	T-branch
	11	Heating coil pipes

YUTAKI S is not factory-supplied ready for DHW operation, but it can be used for the production of DHW if the following elements are installed:

- **A domestic hot water tank (DHWT-(200/260)S-3.0H2E accessory) (8)** has to be installed in combination with the indoor unit.
- **A 3-way valve (ATW-3WV-01 accessory) (9)** must be connected at one point of the water outlet pipe of the installation.
- **A T-branch (field supplied) (10)** must be connected at one point of the water inlet pipe of the installation.
- **Two water pipes (field supplied) (11)**. One pipe between 3-way valve and the heating coil inlet (3) of the DHW tank, the other one between the T-branch and the heating coil outlet (4) of the DHW tank.

Additionally, the following elements are required for the DHW circuit:

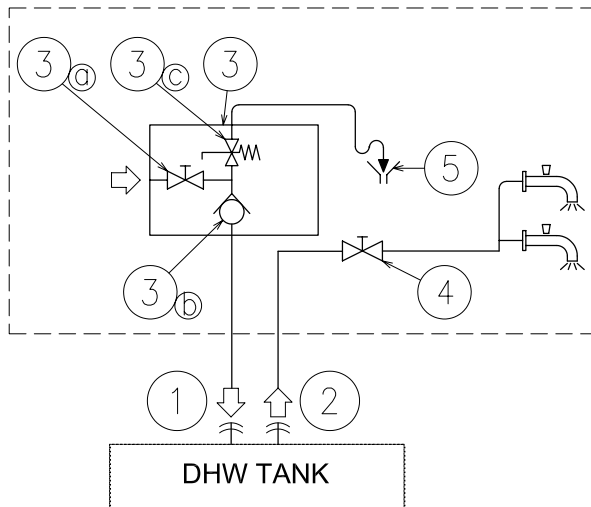

Nature	N°	Part name	
Piping connections	1	Water inlet (DHW)	
	2	Water outlet (DHW)	
Field supplied	3	Pressure and temperature relief valve	
		3a	Shut-off valve
		3b	Water check valve
	3c	Pressure relief valve	
	4	Shut-off valve	
5	Draining		

- **1 Shut-off valve (field supplied):** one shut-off valve (4) must be connected after the DHW outlet connection of the DHW tank (2) in order to make easier any maintenance work.
- **A Security water valve (Field-supplied):** this accessory (3) is a pressure and temperature relief valve that must be installed as near as possible to the DHW inlet connection of the DHW tank (1). It should ensure a correct draining (5) for the discharge valve of this valve. This security water valve should provide the following:
 - Pressure protection
 - Non-return function
 - Shut-off valve
 - Filling
 - Draining

i NOTE

The discharge pipe should always be open to the atmosphere, free of frost and in continuous slope to the down side in case that water leakage exists.

4.3.3 Additional hydraulic optional elements (For DHW)

In case of a recirculation circuit for the DHW circuit:

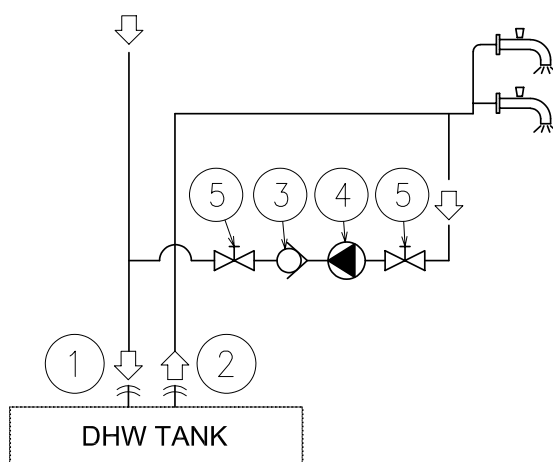

Nature	N°	Part name
Piping connections	1	Water inlet (DHW)
	2	Water outlet (DHW)
Accessories	3	Water check valve (ATW-WCV-01 accessory)
Field supplied	4	Water pump
	5	Shut-off valve

- **1 Recirculation water pump (field supplied):** this water pump (3) will help to correctly recirculate the hot water to the DHW inlet.
- **1 Water check valve (ATW-WCV-01 accessory):** this HITACHI accessory (3) is connected after the recirculation water pump (4) in order to ensure the non-return of water.
- **2 Shut-off valves (field supplied) (5):** one before the recirculation water pump (4) and other after the water check valve accessory (3).

4.3.4 Requirements and recommendations for the hydraulic circuit

- The maximum piping length depends on the maximum pressure availability in the water outlet pipe. Please check the pump curves.
- The indoor unit is equipped with an air purger (factory supplied) at the highest location of the Indoor Unit. If this location is not the highest of the water installation, air might be trapped inside the water pipes, which could cause system malfunction. In that case additional air purgers (field supplied) should be installed to ensure no air enters the water circuit.
- For heating floor system, the air should be purged by means of an external pump and an open circuit to avoid air bags.
- When the unit is stopped during shut-off periods and the ambient temperature is very low, the water inside the pipes and the circulating pump may freeze, thus damaging the pipes and the water pump. In these cases, the installer shall ensure that the water temperature inside the pipes does not fall below the freezing point. In order to prevent this, the unit has a self-protection mechanism which should be activated (refer to the Service manual, “*Optional functions*” chapter).
- Check that the water pump of the space heating circuit works within the pump operating range and that the water flow is over the pump’s minimum. If the water flow is below 12 litres/minute (6 litres/minute for 2.0/2.5/3.0HP unit), alarm is displayed on the unit.
- An additional special water filter is highly recommended to be installed on the space heating (field installation), in order to remove possible particles remaining from brazing which cannot be removed by the indoor unit water strainer.
- When selecting a tank for DHW operation, take into consideration the following points:
 - The storage capacity of the tank has to meet with the daily consumption in order to avoid stagnation of water.
 - Fresh water must circulate inside the DHW tank water circuit at least one time per day during the first days after the installation has been performed. Additionally, flush the system with fresh water when there is no consumption of DHW during long periods of time.
- Try to avoid long runs of water piping between the tank and the DHW installation in order to decrease possible temperature losses.
- If the domestic cold water entry pressure is higher than the equipment’s design pressure (6 bar), a pressure reducer must be fitted with a nominal value of 7 bar.
- Ensure that the installation complies with applicable legislation in terms of piping connection and materials, hygienic measures, testing and the possible required use of some specific components like thermostatic mixing valves, Differential pressure overflow valve, etc.
- The maximum water pressure is 3 bar (nominal opening pressure of the safety valve). Provide adequate reduction pressure device in the water circuit to ensure that the maximum pressure is NOT exceeded.
- Ensure that the drain pipes connected to the safety valve and to the air purger are properly driven to avoid water being in contact with unit components.
- Make sure that all field supplied components installed in the piping circuit can withstand the water pressure and the water temperature range in which the unit can operate.
- YUTAKI units are conceived for exclusive use in a closed water circuit.
- The internal air pressure of the expansion vessel tank will be adapted to the water volume of the final installation (factory supplied with 0.1 MPa of internal air pressure).
- Do not add any type of glycol to the water circuit.
- Drain taps must be provided at all low points of the installation to permit complete drainage of the circuit during servicing.

4.3.5 Water filling

- 1 Check that a water check valve (ATW-WCV-01 accessory) with a shut-off valve (field supplied) is connected to the water filling point (water inlet connection) for filling the space heating hydraulic circuit (see "4.3 Space heating and DHW").
- 2 Make sure all the valves are open (water inlet/outlet shut-off valves and the rest of valves of the space heating installation components).
- 3 Ensure that the air purgers of the indoor unit and installation are open (turn the indoor unit air purger twice at least).
- 4 Check that the drain pipes connected to the safety valve (and to the drain pan in case of installing the "Cooling kit" accessory) are correctly connected to the general draining system. The safety valve is later used as an air purging device during the water filling procedure.
- 5 Fill the space heating circuit with water until the pressure displayed on the manometer reaches approximately 1.8 bar.
- 8 If a little quantity of air is still remaining in the water circuit, it will be removed by the automatic air purger of the indoor unit during the first hours of operation. Once the air in the installation has been removed, a reduction of water pressure in the circuit is very likely to occur. Therefore, additional water should be filled until water pressure returns to an approximate level of 1.8 bar.

NOTE

- The indoor unit is equipped with an automatic air purger (factory supplied) at the highest location of the indoor unit. Anyway, if there are higher points in the water installation, air might be trapped inside water pipes, which could cause system malfunction. In that case, additional air purgers (field supplied) should be installed to ensure no air enters into the water circuit. The air vents should be located at points which are easily accessible for servicing.
- The water pressure indicated on the indoor unit manometer may vary depending on the water temperature (the higher temperature, the higher pressure). Nevertheless, it must remain above 1 bar in order to prevent air from entering the circuit.
- Fill in the circuit with tap water. The water in the heating installation must comply with EN directive 98/83 EC. Non-sanitary controlled water is not recommended (for example, water from wells, rivers, lakes, etc.) (See "Water quality" section at the CD-ROM).
- The maximum water pressure is 3 bar (nominal opening pressure of the safety valve). Provide adequate reduction pressure device in the water circuit to ensure that the maximum pressure is NOT exceeded.
- For heating floor system, air should be purged by means of an external pump and an open circuit to prevent the formation of air pockets.
- Check carefully for leaks in the water circuit, connections and circuit elements.

NOTE

While the system is being filled with water, it is highly recommended to operate the safety valve manually so as to help with the air purging procedure.

- 6 Remove as much air from inside the water circuit as possible through the indoor air purger and other air vents in the installation (fan coils, radiators...).
- 7 Start the air purge procedure test. There are two modes (Manual or Automatic) which helps in case of installations with heating and DHW operation:
 - a. Manual: Start and stop the unit manually using the unit controller (Run/Stop button) and also using the DSW4 pin 2 of the PCB1 (ON: Forced to derive to DHW coil; OFF: Forced to derive to space heating).
 - b. Automatic: Select the air purge function using the user controller. When the automatic air purge function is running, the pump speed and the position of the 3-way valve (space heating or DHW) are automatically changed.

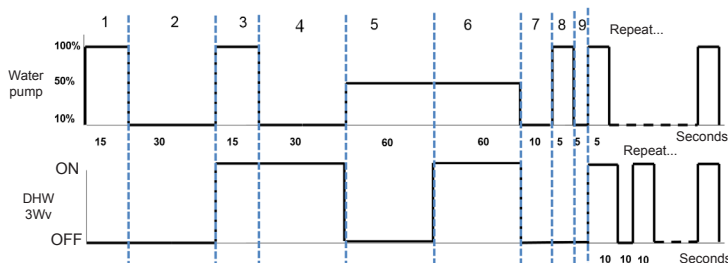

5 ELECTRICAL AND CONTROL SETTINGS

5.1 GENERAL CHECK

- Make sure that the following conditions related to power supply installation are satisfied:
 - The power capacity of the electrical installation is large enough to support the power demand of the YUTAKI system (outdoor unit + indoor unit + DHW tank (if apply)).
 - The power supply voltage is within $\pm 10\%$ of the rated voltage.
 - The impedance of the power supply line is low enough to avoid any voltage drop of more than 15% of the rated voltage.
- Following the Council Directive 2004/108/EC, relating to electromagnetic compatibility, the table below indicates the Maximum permitted system impedance Z_{max} at the interface point of the user's supply, in accordance with EN61000-3-11.

Model	Power supply	Operation mode	Z_{max} (Ω) (*)
RWM-(2.0-3.0)NE	1~ 230V 50Hz	Without electric heaters	-
		With electric heater	-
		With DHW tank heater	-
		With electric and DHW tank heaters	0.26
RWM-(4.0-6.0)NE	1~ 230V 50Hz	Without electric heaters	-
		With electric heater	0.26
		With DHW tank heater	-
		With electric and DHW tank heaters	0.17
	3N~ 400V 50Hz	Without electric heaters	-
		With electric heater	-
		With DHW tank heater	-
		With electric and DHW tank heaters	-
RWM-(8.0/10.0)NE	3N~ 400V 50Hz	Without electric heaters	-
		With electric heater	-
		With DHW tank heater	-
		With electric and DHW tank heaters	0.46

NOTE

The data corresponding to DHW tank heater is calculated in combination with the domestic hot water tank accessory "DHWT-(200/300)S-3.0H2E".

- The status of Harmonics for each model, regarding compliance with IEC 61000-3-2 and IEC 61000-3-12, is as follows:

Status regarding compliance with IEC 61000-3-2 and IEC 61000-3-12	Models
Equipment complying with IEC 61000-3-2 (*): Professional use	RWM-2.0NE RWM-2.5NE RWM-3.0NE RWM-4.0NE (3N~) RWM-5.0NE (3N~) RWM-6.0NE (3N~) RWM-8.0NE RWM-10.0NE
Equipment complying with IEC 61000-3-12	RWM-4.0NE (1~) RWM-5.0NE (1~) RWM-6.0NE (1~)
Installation restrictions may be applied by supply authorities in relation to harmonics	-

- Check to ensure that existing installation (mains power switches, circuit breakers, wires, connectors and wire terminals) already complies with the national and local regulations.
- The use of the DHW tank heater is disabled as factory setting. If it is desired to enable the DHW tank heater operation during normal indoor unit operation, adjust the DSW4 pin 3 of the PCB1 to the ON position and use the adequate protections. Refer to the section "5.6 Setting of DIP switches and RSW switches" for the detailed information.

5.2 SYSTEM WIRING DIAGRAM

Connect the units according to the following electric diagram:

- TB : Terminal board
- CB : Circuit breaker
- ELB : Earth leakage breaker
- : Internal wiring
- : Field wiring
- ⊗ : Field-supplied
- 1,2 : Outdoor-Indoor communication

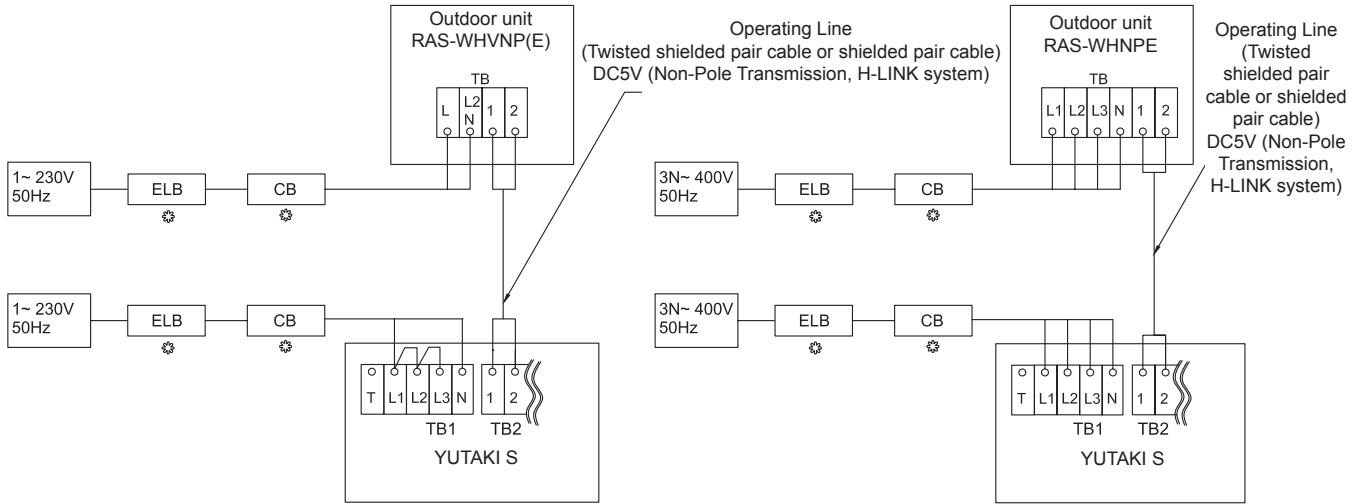

5.3 WIRING SIZE AND MINIMUM REQUIREMENTS OF THE PROTECTION DEVICES

⚠ CAUTION

- Check to ensure that the field supplied electrical components (mains power switches, circuit breakers, wires, connectors and wire terminals) have been properly selected according to the electrical data indicated on this chapter and they comply with national and local codes. If it is necessary, contact with your local authority in regards to standards, rules, regulations, etc.
- Use a dedicated power circuit for the indoor unit. Do not use a power circuit shared with the outdoor unit or any other appliance.

Use wires which are not lighter than the polychloroprene sheathed flexible cord (code designation 60245 IEC 57).

Model	Power supply	Operation mode	Max current (A)	Power supply cables	Transmitting cables	CB (A)	ELB (n° of poles/A/ mA)
				EN60335-1	EN60335-1		
RWM-(2.0-3.0)NE	1~ 230V 50Hz	Without electric heaters	0.2	2 x 0.75 mm ² + GND	2 x 0.75 mm ²	5	2/40/30
		With electric heater	15	2 x 2.5 mm ² + GND		16	
		With DHW tank heater	15	2 x 2.5 mm ² + GND		16	
		With electric and DHW tank heaters	29	2 x 6.0 mm ² + GND		32	
RWM-(4.0-6.0)NE	1~ 230V 50Hz	Without electric heaters	0.3	2 x 0.75 mm ² + GND		5	2/40/30
		With electric heater	29	2 x 6.0 mm ² + GND		32	
		With DHW tank heater	15	2 x 2.5 mm ² + GND		16	
		With electric and DHW tank heaters	43	2 x 10.0 mm ² + GND		50	
	3N~ 400V 50Hz	Without electric heaters	0.3	4 x 0.75mm ² + GND		5	4/40/30
		With electric heater	10	4 x 2.5 mm ² + GND		15	
		With DHW tank heater	15	4 x 2.5 mm ² + GND		15	
		With electric and DHW tank heaters	24	4 x 6.0 mm ² + GND		25	
RWM-(8.0/10.0)NE	3N~ 400V 50Hz	Without electric heaters	0.6	4 x 0.75 mm ² + GND	5	4/40/30	
		With electric heater	15	4 x 4.0 mm ² + GND	20		
		With DHW tank heater	15	4 x 2.5 mm ² + GND	15		
		With electric and DHW tank heaters	29	4 x 6.0 mm ² + GND	30		

i NOTE

The data corresponding to DHW tank heater is calculated in combination with the domestic hot water tank accessory "DHWT-(200/300)S-3.0H2E".

⚠ CAUTION

- Ensure specifically that there is an Earth Leakage Breaker (ELB) installed for the units (outdoor and indoor unit).
- If the installation is already equipped with an Earth Leakage Breaker (ELB), ensure that its rated current is large enough to hold the current of the units (outdoor and indoor unit).

i NOTE

- Electric fuses can be used instead of magnetic Circuit Breakers (CB). In that case, select fuses with similar rated values as the CB.
- The Earth Leakage Breaker (ELB) mentioned on this manual is also commonly known as Residual Current Device (RCD) or Residual Current Circuit Breaker (RCCB).
- The Circuit Breakers (CB) are also known as Thermal-Magnetic Circuit Breakers or just Magnetic Circuit Breakers (MCB).

5.4 TRANSMISSION WIRING BETWEEN OUTDOOR AND INDOOR UNIT

- The transmission is wired to terminals 1-2.
- The H-LINK II wiring system requires only two transmission cables that connect the indoor unit and the outdoor unit.

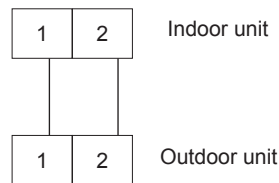

- Use twist pair wires (0.75 mm²) for operation wiring between outdoor unit and indoor unit. The wiring must consist of 2-core wires (Do not use wire with more than 3 cores).
- Use shielded wires for intermediate wiring to protect the units from noise interference, with a length of less than 300 m and a size in compliance with local codes.
- In the event that a conduit tube for field-wiring is not used, fix rubber bushes to the panel with adhesive.

⚠ CAUTION

Ensure that the transmission wiring is not wrongly connected to any live part that could be damaged the PCB.

5.5 OPTIONAL INDOOR UNIT WIRING (ACCESSORIES)

◆ Summary of the terminal board connections

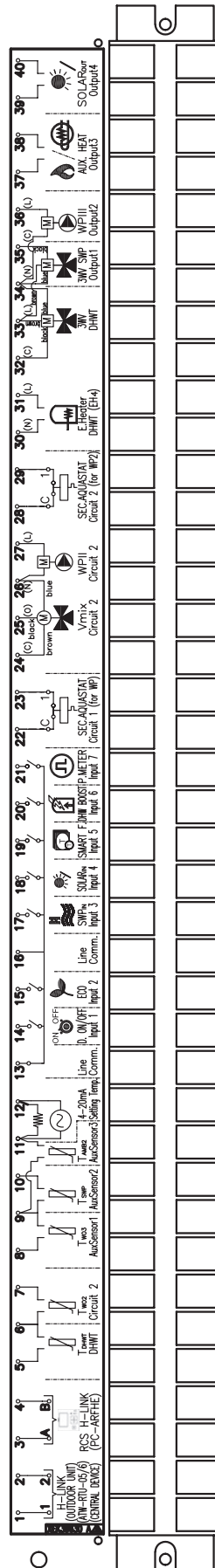

Mark	Part name	Description
TERMINAL BOARD 1 (TB1)		
N	1~ 230V 50Hz 3N~ 400 50Hz	Main power supply connection
L1		
L2		
L3		
TERMINAL BOARD 2 (TB2)		
1	H-LINK commutation	The H-LINK transmission has to be done between the indoor unit and the terminals 1-2 of either outdoor unit, ATW-RTU-05 or any other central device.
2		
3	H-LINK communication for remote control switch	Terminals for the connection of the YUTAKI unit controller.
4		
5	DHW tank's thermistor	The DHW sensor is used to control the temperature of the domestic hot water tank.
6	Common thermistor	Common terminal for thermistor.
7	Thermistor for water outlet temperature of second cycle	The sensor is used for the second temperature control and should be positioned after the mixing valve and the circulation pump.
8	Thermistor for water outlet temperature after hydraulic separator	Water sensor for hydraulic separator, buffer tank or boiler combination.
9	Common thermistor	Common terminal for thermistors.
10	Thermistor for swimming pool water temperature	The sensor is used for the swimming pool temperature control and should be positioned inside plate heat exchanger of the swimming pool.
11	Thermistor for second ambient temperature	The sensor is used for the second ambient temperature control and it should be positioned outdoors.
11	4-20 mA application	It is possible to connect an external controller to the connector CN5 to provide a manual water temperature setting. The input current (4-20 mA) will be transformed into voltage by means of a grounded 240 Ω resistor (ATW-MAK-01 accessory) connected to these terminals. The DSW5 pin 3 must be in ON position and the SSW1 has to be in Local mode (Enabled manual operation) to enable this function.
12		
13	Common line	Terminal Line common for input 1 and input 2.
14	Input 1 (Demand ON/OFF) (*)	The air to water heat pump system has been designed to allow the connection of a remote thermostat to effectively control your home's temperature. Depending on the room temperature, the thermostat will turn the split air to water heat pump system ON and OFF.
15	Input 2 (ECO mode) (*)	Available signal which allows to reduce the water setting temperature of circuit 1, circuit 2 or both.
16	Common line	Terminal Line common for inputs 3, 4, 5, 6, 7.
17	Input 3 (Swimming pool) (*)	Only for swimming pool installations: It is necessary to connect an external input to the air to water heat pump to provide signal when the water pump of swimming pool is ON.
18	Input 4 (Solar) (*)	Available input for Solar combination with Domestic Hot Water Tank.
19	Input 5 (Smart function) (*)	For the connection of an external tariff switch device to switch OFF the heat pump during peak electricity demand period. Depending on the setting, the heat pump or DHWT will be blocked when signal is open/closed.
20	Input 6 (DHW boost) (*)	Available input for an instantaneous heating of the domestic hot water of the tank.
21	Input 7 (Power meter)	The measuring of the real power consumption can be done connecting an external power meter. The number of pulses of the power meter is a variable which must be set. By this, every pulse input is added into corresponding operation mode (Heating, Cooling, DHW Operation). Two possible options: - One power meter for all installation (IU+OU). - Two separated power meters (one for IU and one for OU).
22	Aquastat security for circuit 1 (WP1)	Terminals intended for the connection of the Aquastat security accessory (ATW-AQT-01) for controlling water temperature of the circuit 1.
23		
24(C)	Mixing valve close	When a mixing system is required for a second temperature control, these outputs are necessary to control the mixing valve.
25(O)	Mixing valve open	
26(N)	N Common	
27(L)	Water Pump 2 (WP2)	When there is a second temperature application, a secondary pump is the circulating pump for the secondary heating circuit.
28	Aquastat security for circuit 2 (WP2)	Terminals intended for the connection of the Aquastat security accessory (ATW-AQT-01) for controlling water temperature of the circuit 2.
29		
30(N)	Electrical Heater DHW Output	If DHW tank contains an electric heater, the air to water heat pump can activate it if the heat pump cannot achieve the required DHW temperature by itself.
31(L)		

Mark	Part name	Description
32(C)	Common line	Common terminal for the 3-way valve for DHW tank.
33(L)	3-way valve for DHW tank	The air to water heat pump can be used to heat DHW. This output will be on when DHW is activated.
34(N)	N common	Neutral terminal common for 3-way valve of DHW tank and outputs 1 and 2.
35(L)	Output 1 (3-way valve for swimming pool) (*)	The air to water heat pump can be use to heat swimming pool. This output will be ON when swimming pool is activated.
36(L)	Output 2 (Water pump 3 (WP3)) (*)	When there is a hydraulic separator or buffer tank, additional water pump (WP3) is needed.
37	Output 3 (Auxiliary boiler or electric heater) (*)	The boiler can be used to alternate with the heat pump when the heat pump cannot achieve the required temperature by itself.
38		A water electric heater (as accessory) can be used to provide the additional heating required on the coldest days of the year.
39	Output 4 (Solar) (*)	Output for solar combination with Domestic Hot Water Tank.
40		

i NOTE

(*): Inputs and outputs explained in the table are the factory-set options. By means of the unit controller, some other inputs and outputs functions can be configured and used. Please, refer to the Service Manual for detailed information.

5.6 SETTING OF DIP SWITCHES AND RSW SWITCHES

5.6.1 Location of DIP switches and rotary switches

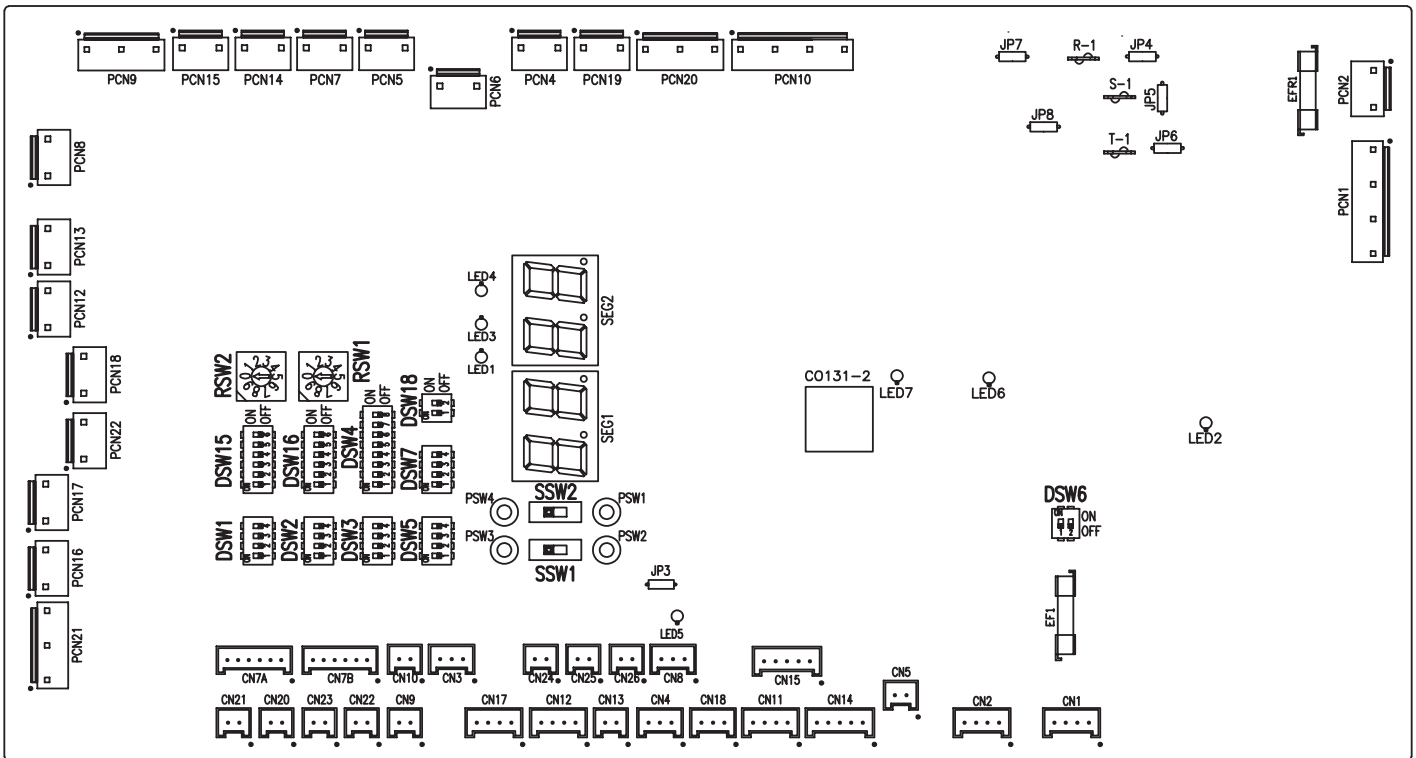

5.6.2 Function of DIP switches and rotary switches

NOTE

- The mark “■” indicates the dip switches positions.
- No mark “■” indicates pin position is not affected.
- The figures show the settings before shipment or after selection.
- “Not used” means that the pin must not be changed. A malfunction might occur if changed.

CAUTION

Before setting dip switches, first turn the power supply OFF and then set the position of dip switches. If the switches are set without turning the power supply OFF, the contents of the setting are invalid.

◆ DSW1: Additional setting 0

Factory setting. No setting is required.







Factory setting	
-----------------	---

NOTE

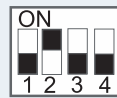
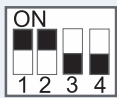

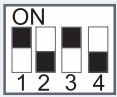
In case of installing the “Cooling kit” accessory, set the pin 4 of DSW1 to ON in order to enable the cooling operation.

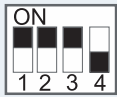
◆ DSW2: Unit capacity setting

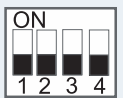

No setting is required.

2.0 HP	2.5 HP	3.0 HP	4.0 HP
			
5.0 HP	6.0 HP	8.0 HP	10.0 HP
			

◆ DSW3: Additional setting 1

Setting before shipment	
1-step heater for 3-phase unit	

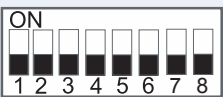
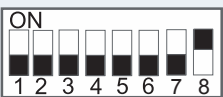
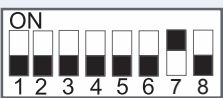
◆ DSW4: Additional setting 2

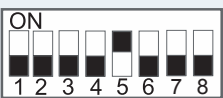
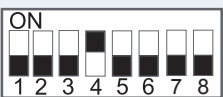
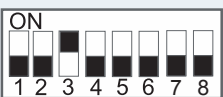
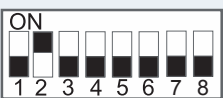
Setting before shipment	
DHW defrost	
Heater forced OFF	
Unit and installation pipes antifreeze protection	
Standard / ECO water pump operation	
Electric heater or boiler emergency mode	
DHW tank's heater operation	
DHW 3-way valve forced ON	

CAUTION

- Never turn all DSW4 dip switch pins ON. If this happens, the software of the unit will be removed.
- Never activate “Heater Forced OFF” and “Electric heater or boiler emergency mode” at the same time.

◆ **DSW5: Additional setting 3**

In the cases where the outdoor unit is installed into a location where its own outdoor ambient temperature sensor can not give a suitable temperature measurement to the system, it is available the 2nd outdoor ambient temperature sensor as accessory. By means of DSW1&2 setting, the preferable sensor for each circuit can be selected.

Factory setting	
Outdoor unit sensor for circuits 1 and 2.	
Outdoor unit sensor for circuit 1; Auxiliary sensor for circuit 2.	
Auxiliary sensor for circuit 1; Outdoor unit sensor for circuit 2.	
Auxiliary sensor instead of outdoor unit sensor for both circuits.	
4-20 mA setting temperature (Only manual operation)	
Use the maximum temperature value between Two3 (boiler / heater thermistor) and Two (water outlet thermistor) for water control	

◆ **DSW6: Not used**

Factory setting (Do not change)	
------------------------------------	--

◆ **DSW7: Additional setting 4**

Factory setting	
Defrost for the water electric heater	

◆ **DSW18: Not used**

Factory setting (Do not change)	
------------------------------------	--

◆ **DSW15 & RSW2: Not used**

Factory setting (Do not change)		
------------------------------------	--	--

◆ **DSW16 & RSW1: Not used**

Factory setting (Do not change)		
------------------------------------	--	--

◆ **SSW1: Remote/Local**

Factory setting (Remote operation)	Remote
Local operation	Local

◆ **SSW2: Heat/Cool**

Factory setting (Heat operation)	Heat
Cool and Heat operation in case of Local	Cool

5.6.3 LED indication

Name	Colour	Indication
LED1	Green	Power indication
LED2	Red	Power indication
LED3	Red	Heat pump operation (thermo ON/OFF)
LED4	Yellow	Alarm (flickering with 1 sec interval)
LED5	Green	Not used
LED6	Yellow	H-Link transmission
LED7	Yellow	H-Link transmission for unit controller

6 UNIT INSTALLATION

6.1 GENERAL NOTES

6.1.1 Components at receipt

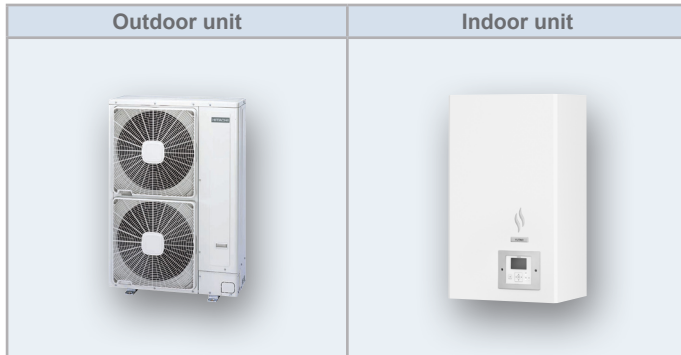

i NOTE

For outdoor unit installation information, please refer to the outdoor unit Installation and operational manual.

6.1.2 Selection of the installation location

The indoor unit of the split system with air to water heat pump must be installed following these basic requirements:

- The indoor unit is intended to be installed in an indoor place and for ambient temperatures ranging 5~30°C. The ambient temperature around the indoor unit must be >5°C to prevent water from freezing.
- The unit is prepared to be wall mounted (wall bracket is factory supplied), so make sure that selected wall is flat and is made of a non-combustible surface, strong enough for supporting the indoor unit weight.
- Be sure to maintain the recommended servicing space for future unit servicing and guarantee enough air circulation around the unit (See "3.1 Service space" section).
- Take into account that two shut-off valves (factory supplied) must be installed at the indoor unit inlet/outlet connections.
- Keep water draining provisions. The safety valve and the air purge are provided with a drain pipe which are located at the bottom side of the unit.
- If the event of installing the "Cooling kit" accessory, the installer is responsible for proper installation and draining.
- Protect the indoor unit against the entry of small animals (like rats) which could making contact with the wires, the drain pipe, electrical parts and may damage unprotected parts, and at the worst, a fire will occur.
- Install it in a no-frost environment.
- Do not install the indoor unit in a location with very high humidity.
- Do not install the indoor unit where electromagnetic waves are directly radiated to the electrical box.

- Install the unit in a place where in case of water leakage, any damage to the installation space cannot be produced.
- Install noise filter when the power supply emits harmful noises.
- To avoid fire or explosion, do not install the unit in a flammable environment.
- The air to water heat pump must be installed by a service technician. The installation must comply with local and European regulations.
- Try to avoid to put any objects or tools above the indoor unit.

6.1.3 Unpacking

All units are supplied with a wooden base, packed by a cardboard box and plastic bag.

Firstly to unpack it, place the unit on the assembly area as close as possible to its final installation location, to avoid damages in transport. Two persons are required.



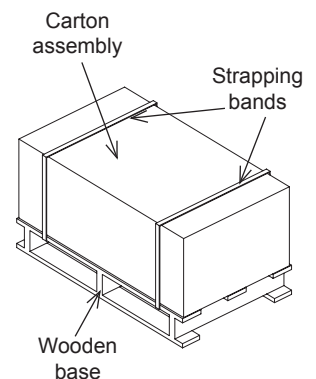

- 1 Cut the strapping bands and remove the adhesive tapes.
- 2 Remove the carton assembly and then the plastic bag around the unit.
- 3 Unscrew the 4 screws which fix the unit to the wooden base.
- 4 Remove the indoor unit from the wooden base and place it carefully on the floor, as near as possible to its final location.



! CAUTION

- Be careful with the Installation and Operation manual and with the factory-supplied accessories box located besides the unit.
- Two people are required when lifting because of the weight of the unit.

6.1.4 Factory-supplied indoor unit components

Accessory	Image	Qty.	Purpose
Shut-off valve (2-3HP: 1") (4-10HP: 1-1/4")		2	To make easier the installation work in the space heating water inlet/outlet connections. For a better servicing.
Gasket		4	Two gaskets for each space heating connections (inlet/outlet)
Wall support		1	For hanging the unit on the wall
CD-ROM		1	With the detailed Installation and operation manual
Instruction manual		1	Basic instructions for the installation of the device.
Declaration of conformity	-	1	-

6.1.5 Indoor unit main parts (Descriptions)

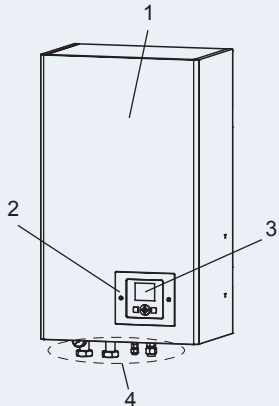
Nº	Part	
1	Indoor unit service cover	
2	Unit controller frame	
3	Unit controller	
4	Piping connections	

i NOTE

- The previous accessories are supplied inside the packing assembly (besides the indoor unit).
- Additional refrigerant piping (field supplied) for connections to outdoor unit needs to be available.
- If some of these accessories are not packed with the unit or any damage to the unit is detected, please contact your dealer.

6.2 REMOVING THE COVERS

If it is necessary to access to the indoor unit components, please follow these operations.

6.2.1 Removing the indoor unit service cover

i NOTE

The indoor unit service cover needs to be removed for any task inside the indoor unit.

- 1 Unscrew the 2 screws which fixes the frame of the unit controller to the indoor unit service cover.

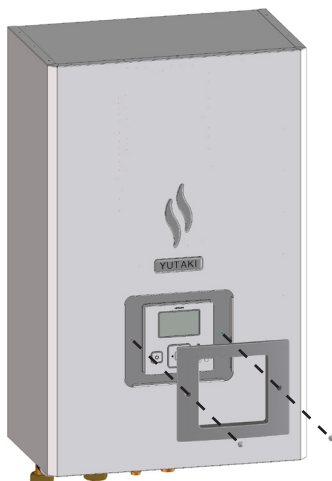

- 2 Slide the service cover slightly upward and remove it pulling to back.

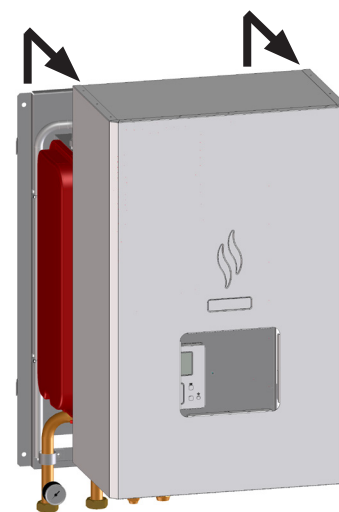

! CAUTION

- Take care with the LCD display of the unit controller while removing the frame.
- Pay attention of no falling off the service cover.
- Take care when removing service cover; the parts inside the unit could be hot.

6.2.2 Removing indoor unit electrical box

DANGER

- *Disconnect the unit from the power supply before touching any of the parts in order to avoid an electrical shock.*
- *Do not touch the switch for DHW tank heater operation when handling the electrical box. Keep the position of this switch in factory setting position ("Automatic" operation).*

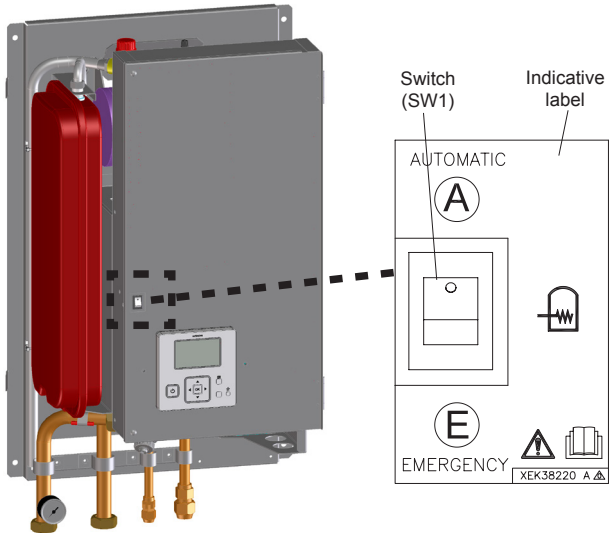

RWM-(4.0-10.0)NE

- 1 Remove the indoor unit service cover as explained above.
- 2 Unscrew the 4 front screws of the electrical box cover and then, remove it.

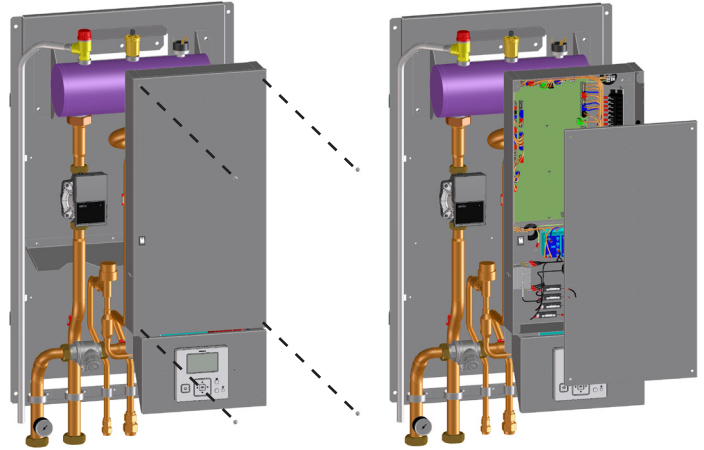

CAUTION

Take care with the electrical box components in order to avoid damaging it.

◆ Remove the electrical box cover

RWM-(2.0-3.0)NE

- 1 Remove the indoor unit service cover as explained above.
- 2 Unscrew the 2 front screws of the electrical box cover and then, rotate it.

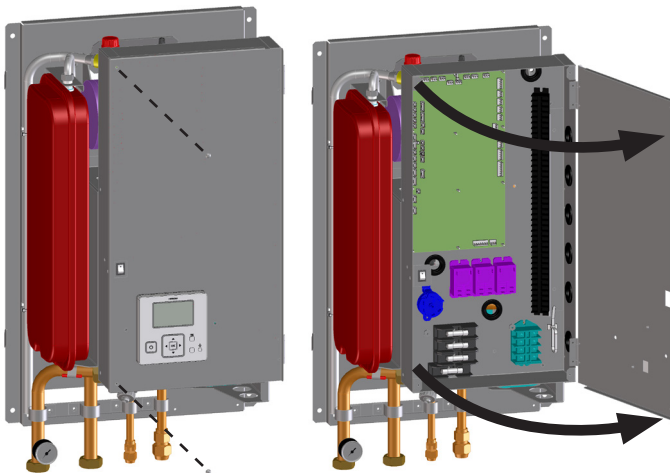

CAUTION

Take care with the electrical box components in order to avoid damaging it.

6.3 INSTALLATION OF INDOOR UNIT

i NOTE

Please, try to perform all this procedure following all the steps in the exact order in which they are presented below.

Installation procedure

- 1 Wall mounting procedure
- 2 Space heating pipes connection
- 3 Drain pipes connection
- 4 Refrigerant piping connection
- 5 Power and transmission wiring connection
- 6 Cover assembly
- 7 Test and check

6.3.1 Wall mounting procedure

- 1 Fix the wall support (factory-supplied accessory) to the wall using appropriate plugs and screws. Make sure that the wall support is completely levelled.

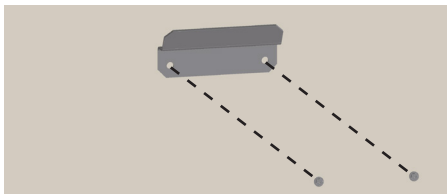

- 2 Hang the indoor unit on the wall support (at least two persons are required in order to lift the unit because of its weight).

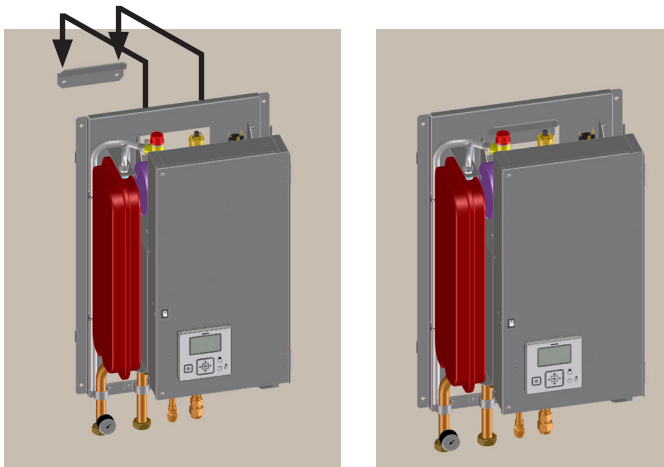

- 3 Fix the indoor unit at the bottom side using the 4 screws which had been previously removed during the unpacking procedure.

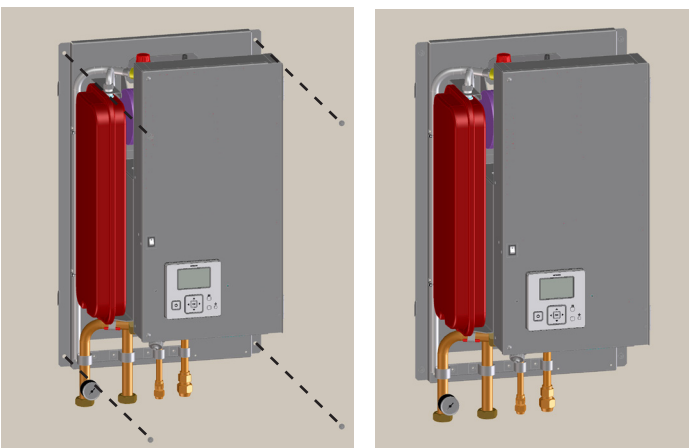

6.3.2 Space heating pipes connection

The unit is factory supplied with two shut-off valves which have to be connected to the water inlet / outlet connections. With these shut-off valves it is very practical to connect the indoor unit to the heating system by using the factory supplied gaskets just below the valves (G 1" connection for 2.0-3.0HP; G 1-1/4" connection for 4.0-10.0HP). Then, the space heating installation can be carried out.

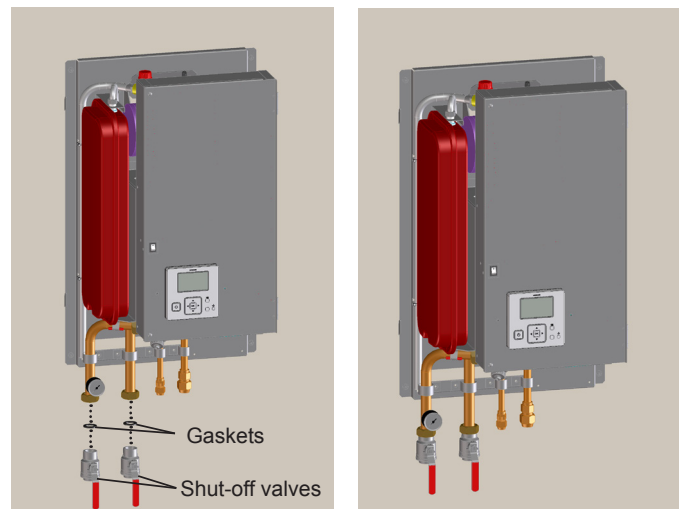

6.3.3 Drain pipes connection

For a correct drainage, connect the drain pipe for the safety valve to the general draining system.

i NOTE

- The safety valve is activated when water pressure reaches 3 bars.
- Drain taps must be provided at all low points of the installation to permit complete drainage of the circuit during servicing.

6.3.4 Refrigerant piping connection

Make the connection of refrigerant pipes respecting the considerations indicated in the CD-ROM factory-supplied with the unit.

The refrigerant piping connections are flare nut except in case of the gas connection of the 10.0 HP model, which is a brazed connection.

6.3.5 Power and transmission wiring connection

◆ Connection procedure

◆ Safety instructions

i NOTE

Check the requirements and recommendations in the chapter "5 ELECTRICAL AND CONTROL SETTINGS"

! DANGER

- Do not connect the power supply to the indoor unit prior to filling the space heating circuit (and DHW circuit if it were the case) with water and checking water pressure and the total absence of any water leakage.
- Do not connect or adjust any wiring or connections unless the main power switch is OFF.
- When using more than one power source, check and ensure that all of them are turned OFF before operating the indoor unit.
- Avoid wiring installation in contact with the refrigerant pipes, water pipes, edges of plates and electrical components inside the unit to prevent damage, which may cause electric shock or short circuit.

! CAUTION

- Use a dedicated power circuit for the indoor unit. Do not use a power circuit shared with the outdoor unit or any other appliance.
- Make sure that all wiring and protection devices are properly selected, connected, identified and fixed to the corresponding terminals of the unit, specially the protection (earth) and power wiring, taking into account the applicable national and local regulations. Establish proper earthing; Incomplete earthing may cause electrical shock.
- Protect the indoor unit against the entry of small animals (like rodents) which could damage the drain pipe and any internal wire or any other electrical part, leading to electric shock or short-circuit.
- Keep a distance between each wiring terminal and attach insulation tape or sleeve as shown in the figure.

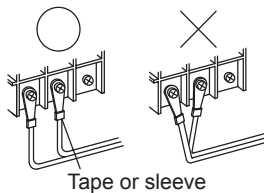

Access to the electrical box before performing the next steps:

- 1 Using the appropriate cable, connect the power circuit to the appropriate terminals as shown on the wiring label and the illustration below. Connect the power supply cables to the terminal board (TB1), and the earth conductor to the earth screw in the electrical box plate.

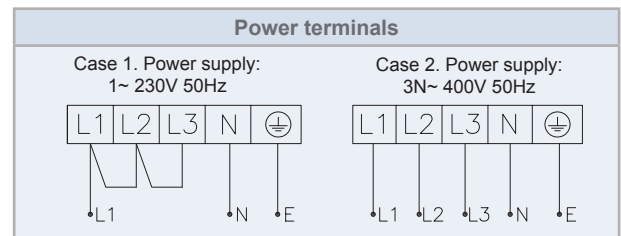
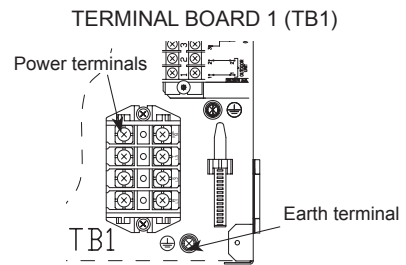

- 2 Connect the transmission wires between outdoor and indoor unit to the terminals 1 and 2 on the terminal board 2 (TB2).

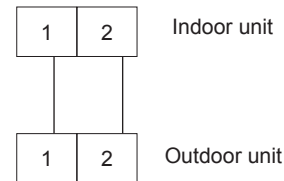

- 3 Carry out the necessary electrical connections of the optional accessories using the terminal board 2 (TB2). Consult its label for a better understanding.

i NOTE

Refer to the section "5.5 Optional indoor unit wiring (accessories)".

- 4 Pass the electrical wiring from the TB1 and TB2 to the lateral holes of the electrical box. Then, fix the cables to the cord bands located at the right side. Finally, take the cables out through the bottom side of the unit.

6.3.6 Cover assembly

- 1 Place the indoor unit service cover at the same level of the wall mounted unit by taking it from the bottom side (one person can perform this operation, during this operation it is possible to rest the cover on the electrical box).

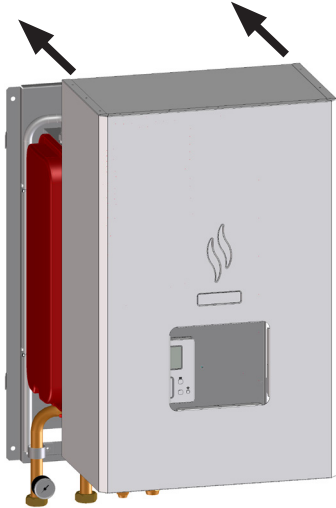

- 2 Place the holes on the right side of the indoor unit cover over the back plate hooks (x2 locations). When the right side is centred, repeat the operation on the left side. Put the holes on the left side of the indoor unit cover into the back plate frame hooks (x2 locations).



CAUTION

Take care not to damage the LCD display of the unit controller when installing the frame.

- 3 Once the 4 hooks are placed into their corresponding cover holes, adjust the cover to the end of the hooks.

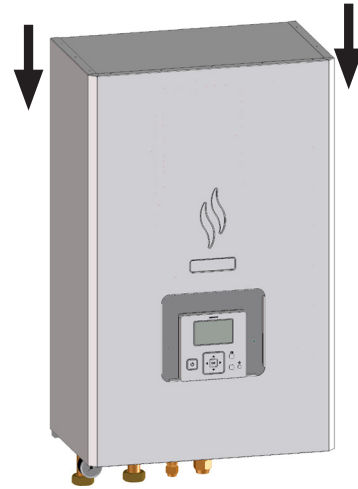

- 4 Fix the user controller frame to the indoor unit service cover using the screws which had been previously removed during the unpacking procedure.



6.3.7 Test and check

Finally, test and check the following items:

- Water leakage
- Refrigerant leakage
- Electrical connection
- ...

NOTE

Please refer to the chapters of “4.2.1 Refrigerant charge”, “4.3.5 Water filling” and “7 COMMISSIONING” in this document and refer the Outdoor unit Installation and Operation manual for the specific details about refrigerant charge tasks.

DANGER

Do not connect the power supply to the indoor unit prior to filling the space heating circuit (and DHW circuit if it were the case) with water and checking water pressure and the total absence of any water leakage.

7 COMMISSIONING

7.1 BEFORE OPERATION

CAUTION

- Supply electrical power to the system for approximately 12 hours before start-up after a long shut-off. Do not start the system immediately after power supply, it may cause compressor failure because the compressor is not well-heated.
- When the system is started after a shut-off longer than approximately 3 months, it is recommended that the system be checked by your service contractor.
- Turn OFF the main switch when the system is to be stopped for a long period of time: as the oil heater is always energized even when the compressor is not working, there will be electricity consumption unless the main switch is turned OFF.

7.2 PRELIMINARY CHECK

When installation is complete, perform commissioning according to the following procedure, and hand over the system to the customer. Perform the commissioning of the units methodically, and check that the electrical wiring and the piping are correctly connected.

Indoor and outdoor units must be configured by the installer to get the perfect setting and the unit working.

NOTE

For the commissioning of the outdoor unit please refer to the outdoor unit installation and operation manual.

7.2.1 Checking the unit

- Check external appearance of the unit to look for any damage due to transportation or installation.
- Check that all the covers are totally closed.
- Check that the recommended service space is respected (see “3.1 Service space” and the outdoor unit Installation and operation manual).
- Check that the unit has been correctly installed onto the wall.

7.2.2 Electrical checking

CAUTION

Do not operate the system until all the check points have been cleared:

- Check to ensure that the electrical resistance is more than 1 MΩ, by measuring the resistance between ground and electrical parts terminal. If not, do not operate the system until the electrical leakage is found and repaired. Do not impress the voltage on the terminals for transmission and sensors .
- Check to ensure that the switch on the main power source has been ON for more than 12 hours, in order to give the oil heater time to warm the compressor.
- In three-phase unit check phase sequence connection on terminal board.
- Check the power supply voltage ($\pm 10\%$ of the rated voltage).
- Check that field-supplied electrical components (main switches, breakers, wires, conduit connectors and wire terminals) have been properly selected according to the electrical specifications given in this document, and check that the components comply with national and local standards.
- Do not touch any electrical components for more than three minutes after turning OFF the main switch
- Check the dip switch settings of the indoor unit and the outdoor unit are connected as shown in the corresponding chapter.

- Check to ensure the electrical wiring of the indoor unit and the outdoor unit are connected as shown in the chapter.
- Check to ensure the external wiring is correctly fixed. To avoid problems with vibrations, noises and cut out wires with the plates.

7.2.3 Hydraulic circuit checking (space heating and DHW)

- Check that the circuit has been properly flushed and filled with water and that the installation has been drained: the pressure of the heating circuit must be 1.8 bar.
- Check for any leakage in water cycle. Pay special attention to the water piping connections.
- Make sure the system's internal water volume is correct.
- Check that the hydraulic circuit's valves are fully open.
- Check to see that electrical heater is completely filled with water by operating pressure of safety valve.
- Check to see that additional water pumps (WP2 or/and WP3) are correctly connected to terminal board.

CAUTION

- Operating the system with closed valves will damage the unit.
- Check to see that air purge valve is open and that the hydraulic circuit is air purged. The installer is responsible of completely air purging the installation.
- Check that the water pump of the space heating circuit works within the pump operating range and that the water flow is over the pump's minimum. If the water flow is under 12 litres/minute (6 litres/minute for 2.0/2.5/3.0HP unit) (with flow switch tolerance), alarm will be displayed on the unit.
- Remember that water connection must be accordance with local regulations.
- Water quality must comply with EU directive 98/83 EC.
- Electrical heater operation when not completely filled with water will damage the heater.

7.2.4 Checking the refrigerant circuit

- Check to ensure that the stop valves on the gas and liquid lines are fully open.
- Check that the size of the piping and the refrigerant charge comply with the applicable recommendations.
- Check the inside of the unit for refrigerant leakage. If there is a refrigerant leak, call your dealer.
- Check outdoor unit commissioning procedure manual.

7.3 COMMISSIONING PROCEDURE

This procedure is valid regardless of what options are on the module.

- When installation is complete and all necessary settings (Dip-switches in PCBs and user controller configuration) have been carried out, close the electrical box and place the cabinet as shown in the manual.
- Make the start-up wizard configuration in the user controller.
- Make a test run as shown in item “7.4 Test run / air purge”.
- After test run is completed, start the entire unit or the selected circuit by pressing the OK button.

◆ Initial start-up at low outdoor ambient temperatures

During commissioning and when water temperature is very low, it is important for the water to be heated gradually. Additional optional function can be used for starting at low water temperature conditions: Screed drying function:

- The screed function is used exclusively for the process of drying a newly applied screed to the floor heating system. The process is based on EN-1264 par 4.
- When user activates screed function, the water set point follows a predetermined schedule:

- 1 Water set point is kept constant at 25°C for 3 days.
- 2 Water set-point is set to the maximum Heating supply temperature (but always limited to ≤ 55°C) for 4 days.

7.4 TEST RUN / AIR PURGE

Test run is a working mode used when commissioning the installation. Some settings are made to let the installer an easy job. Air purge function drives the pump in a way for evacuating air bubbles in the installation.

A menu with specific function for commissioning appears by pressing the menu+back buttons for 3 seconds at the installer menu (OK+back buttons).

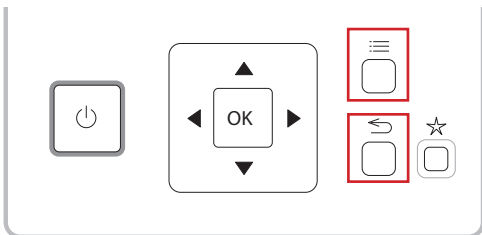

⚠ CAUTION

- Heating at lower water temperatures (approximately 10°C to 15°C) and lower outdoor ambient temperatures (<10°C) can be damaging to the heat pump when defrosting.
- As a result, Heating up to 15°C when outdoor temperature is lower than 10°C is performed by the Electrical Heater.

i NOTE

In case of Heater Forced OFF (by optional dip switch setting) these condition is not performed and heating is performed by Heat Pump. HITACHI is not responsible for its operation.

⚠ CAUTION

It is recommended start the unit (first power ON) with heater forced OFF and compressor forced OFF (See “5.6 Setting of DIP switches and RSW switches”). In order to circulate water by water pump and remove possible air into the heater (Check heater completely filled).

This menu shows the following test to be launched:

- Unit Test Run
- Air Purge
- Screed Drying

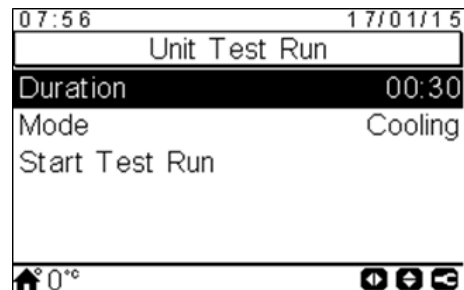

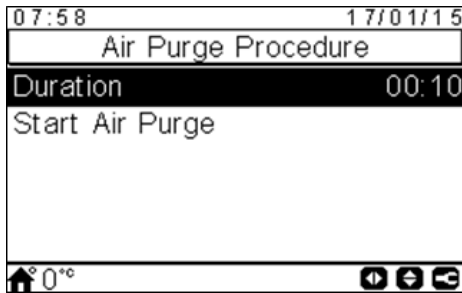

After “Test Run” or “Air Purge” option is selected, the YUTAKI user controller asks for the duration of the test.

In case of test run, user can also select the mode of the test (cooling or heating).

When user confirms the test run or the air purge, the YUTAKI user controller sends the order to the indoor.

During the execution of this test, the following screen is shown:

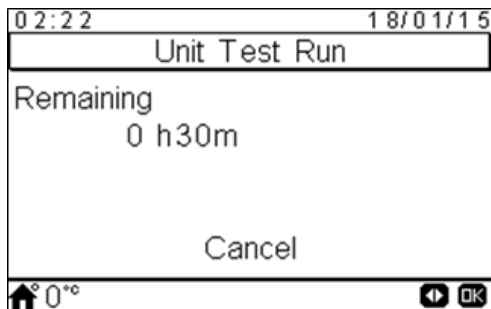

- When the test starts, the user controller will exit from the installer mode.
- If “favourite action button” is pressed during test run, this function will be executed until the user presses the cancel option (this is not-limited by time).
- User can cancel the test run regardless of the time left for test finishing.
- The Test Run icon is shown in the notifications zone, but the notification of this test run is taken from H-LINK.

When test run has finished, an information message is displayed in the screen, and pressing accept, the user returns to the global view.

i NOTE

- *When commissioning and installing the unit, it is very important to use the “Air purge” function to remove all the air in the water circuit. When the air purge function is running, the water pump starts the automatic air venting routine which consists of regulating the speed and open/close configured 3-way valve to help to evacuate air from the system.*
- *For Outdoor test run, refer to Outdoor Unit Installation Manual.*
- *If there is a Heater or a Boiler installed, disable the operation before running the test run.*

8 UNIT CONTROLLER

8.1 DEFINITION OF THE SWITCHES

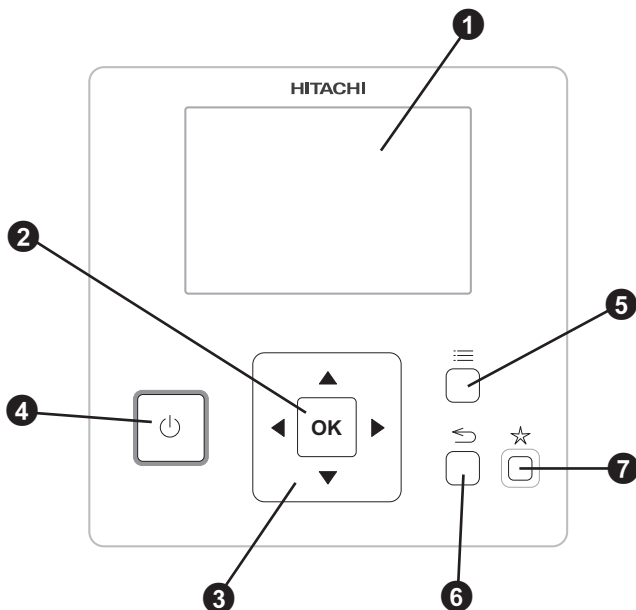

① Liquid Crystal Display

Screen where controller software is displayed.

② OK button

To select the variables to be edited and to confirm the selected values.

③ Arrows key

It helps the user to move through the menus and views.

④ Run/Stop button

It works for all zones if none of the zones is selected or only for one zone when that zone is selected.

⑤ Menu button

It shows the different configuration options of the user controller.

⑥ Return button

To return to the previous screen.

⑦ Favourite button

When this button is pressed, the selected favourite action (ECO/Comfort, Holiday, Simple timer or DHW boost) is directly executed.

8.2 MAIN SCREEN

Depending on the working mode of the user controller, the main screen is shown in a different way. When the user controller is working as a master unit controller, a comprehensive view with all the elements is shown, whereas when the user controller is working as a room thermostat (located in one of the controlled zones), the main screen appears with simplified information.

8.2.1 Comprehensive view

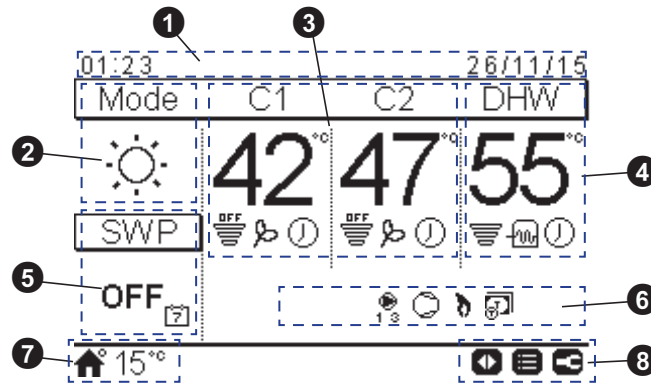

1 Time and date

The current time/date information is displayed. This information can be changed on the configuration menu.

2 Operation mode (Heating / Cooling / Auto)

This icon shows the unit's mode of operation status. It has to be edited by pressing the OK button, and it can be switched between Heating, Cooling and Auto mode (If enabled option).

3 Control of circuits 1 and 2

It displays the setting temperature calculated for each circuit and a throughput icon indicating the percentage of the actual temperature with respect to the setting temperature. It can also show the ECO mode and timer activation if they are enabled.

The setting temperature can be modified using the arrows keys over this view (if Water calculation mode is set as "Fix").

Pressing the OK button, the following options are shown:

- Timer: In this menu, simple timer or schedule timer can be selected and configured.
- OTC: OTC Setting temperature (User can only refer to the OTC mode and its setting temperature value)
- Comfort/ECO: Selection between Comfort and ECO mode.
- Status: Some working conditions can be consulted.

4 DHW control

It displays the setting temperature calculated for DHW and a throughput icon indicating the percentage of the actual temperature with respect to the setting temperature. It can also show the operation of the electrical heater of the DHW, the timer activation and the DHW boost if they are enabled.

The setting temperature can be modified using the arrows keys over this view.

Pressing the OK button, the following options are shown:

- Timer: In this menu, simple timer or schedule timer can be selected and configured.

- DHW boost: It activates the DHW heater for an immediate DHW operation

- Status: Some working conditions can be consulted.

If anti-legionella operation is working, its icon appears below the setting temperature.

5 Swimming pool control

It gives information about the swimming pool setting temperature and displays a throughput icon indicating the percentage of the actual temperature with respect to the setting temperature.

The setting temperature can be modified using the arrows keys over this view.

Pressing the OK button, the following options are shown:

- Timer: In this menu, simple timer or schedule timer can be selected and configured.
- Status: Some working conditions can be consulted.

6 Unit status signals

This part of the screen displays all the notification icons that offer general knowledge on the unit's situation

Some of these icons can be: Defrost operation, Water pumps, Compressor/s, Boiler working, Tariff input, Test tun...

7 Outdoor temperature / Alarm indication

In normal operation, the outdoor temperature is displayed besides the home icon signal.

In abnormal operation, the alarm icon is indicated with its corresponding alarm code.

8 Available buttons / Installer mode

It indicates the buttons of the user controller which can be used in that moment.

When Installer mode is enabled, its icon appears on the right side of this view.

8.2.2 Room thermostat view

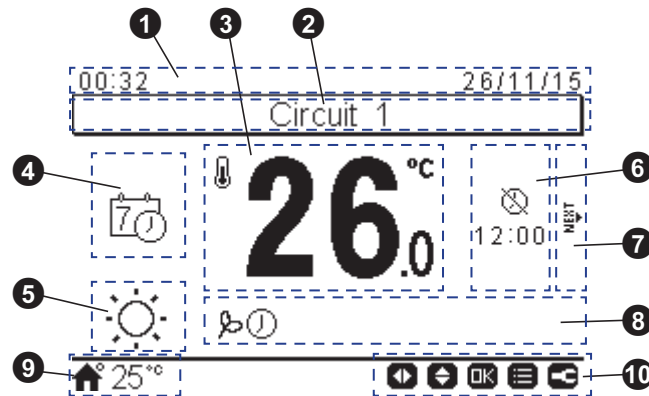

1 Time and date

The current time/date information is displayed. This information can be changed on the configuration menu.

2 Definition of the circuit

It informs about which circuit is being indicated (1 or 2).

3 Actual/Setting room temperature

It displays the actual room temperature. The setting temperature can be adjusted using the up/down arrows keys. In this case, while the setting temperature is being modified, the icon of the actual room temperature is indicated below the setting temperature (house icon).

4 Room thermostat mode

In this part of the screen, the room thermostat mode can be selected between Manual and Auto. If Auto is selected, two possible icons can be displayed: one if a timer period has been selected and the other one if not.

5 Operation mode (Heating / Cooling / Auto)

The current operation mode is displayed. To configure it, press OK to enter in the quick actions (Auto if enabled option).

6 End of timer/holiday operation

In this area, the end hour of the simple timer, holiday period or schedule action is indicated below its respective icon.

◆ OK button

Pressing the OK button, the quick actions are shown:

- Timer: In this menu, simple timer or schedule timer can be selected and configured.
- Operation mode: It allows to select the unit operation between Heating, Cooling and Auto mode (if enabled option).
- ECO/Comfort: Selection between ECO and Comfort mode.
- Holiday: It allows to start a holiday period until the configured returning date and time.
- Status: Some working conditions can be consulted.

7 Next circuit

It informs that there is a room thermostat view for a second circuit and it is possible to access by pressing the right key.

8 Icons notification

This part of the screen displays all the notification icons that offer general knowledge on the unit's situation

Some of these icons can be: ECO mode, Timer operation...

9 Outdoor temperature / Alarm indication

In normal operation, the outdoor temperature is displayed besides the home icon signal.

In abnormal operation, the alarm icon is indicated with its corresponding alarm code.

10 Available buttons / Installer mode

It indicates the buttons of the user controller which can be used in that moment.

When Installer mode is enabled, its icon appears on the right side of this view.

8.3 DESCRIPTION OF THE ICONS















8.3.1 Common icons

Icon	Name	Values	Explanation
OFF	Status for circuit 1, 2, DHW and swimming pool.		Circuit I or II is in Demand-OFF
		Circuit I or II is on Thermo-OFF	
		Circuit I or II is working between 0 < X ≤ 33% of the desired water outlet temperature	
		Circuit I or II is working between 33 < X ≤ 66% of the desired water outlet temperature	
		Circuit I or II is working between 66 < X ≤ 100% of the desired water outlet temperature	
	Mode		Heating
			Cooling
			Auto
88	Setting temperatures	Value	Displays the setting temperature of the circuit 1, circuit 2, DHW and swimming pool
		OFF	Circuit 1, Circuit 2, DHW or Swimming Pool are stopped by button or timer
	Alarm		Existing alarm. This icon appears with the alarm code
	Timer		Simple timer
			Weekly timer
	Derogation		When there is a derogation from the configured timer
	Installer mode		Informs that user controller is logged on the installer mode which has special privileges
	Menu lock		It appears when menu is blocked from a central control. When indoor communication is lost, this icon disappears
	Outdoor temperature		The ambient temperature is indicated at the right side of this button

8.3.2 Icons for the comprehensive view

Icon	Name	Values	Explanation
	Pump		This icon informs about pump operation. There are three available pumps on the system. Each one is numbered, and its corresponding number is displayed below to the pump icon when it is operating
	Heater step		Indicates which of the 3 possible heater steps is applied on space heating
	DHW Heater		Informs about DHW Heater operation. (If it is enabled)
	Solar		Combination with solar energy
	Compressor		Compressor enabled
	Boiler		Auxiliary boiler is working
	Tariff		Tariff signal informs about some cost conditions of the consumption of the system
	Defrost		Defrost function is active
	Central/Local	-	No icon means local mode
	Central/Local		Central mode (Three types of control: Water, Air or Full)
	Forced OFF		When forced off Input is configured and its signal is received, all the configured items on the comprehensive view (C1, C2, DHW, and/or SWP) are shown in OFF, with this small icon below
	Auto ON/OFF		When daily average is over auto summer switch-off temperature, circuits 1 & 2 are forced to OFF (Only if Auto ON/OFF enabled)
TEST RUN	Test Run	TEST RUN	Informs about the activation of the "Test Run" function
ANTI LEG	Anti-Legionella	ANTI LEG	Activation of the Anti-Legionella operation
	DHW boost		It activates the DHW heater for an immediate DHW operation
	ECO/Comfort mode for circuits 1 & 2	-	No icon means Comfort mode
			ECO mode

8.3.3 Icons for the room thermostat view

Icon	Name	Values	Explanation
	Manual/Auto mode		Manual mode
			Auto mode with timer setting
			Auto mode without timer setting
	Setting/Room temperature		Setting temperature
			Room temperature
	End of timer period		The end hour of the timer period is indicated below this icon
	End of holiday period		The end hour of the holiday period is indicated below this icon
	Setting temperature		This icon appears while the setting temperature is being changed, and indicates the actual temperature
	Next screen		When room thermostat has been configured for both circuit 1 and 2, this icon appears at the right side of the screen to indicated that there is a 2nd room thermostat view

HITACHI

00000

Johnson Controls-Hitachi Air Conditioning Spain, S.A.U.
Ronda Shimizu, 1 - Políg. Ind. Can Torrella
08233 Vacarisses (Barcelona) Spain

© Copyright 2016 Johnson Controls-Hitachi Air Conditioning Spain, S.A.U. – All rights reserved.



PMML0336B rev.3 - 08/2016

Printed in Spain