



AIRSTAGE™ J-II

Variable Refrigerant Flow System

4. TROUBLE SHOOTING







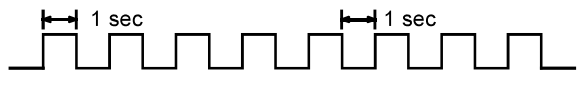
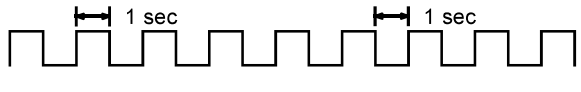
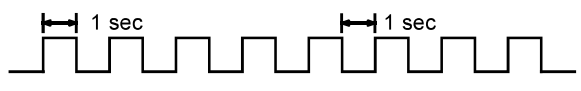
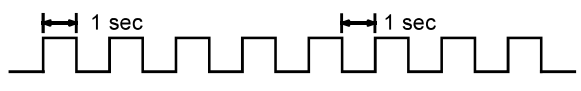
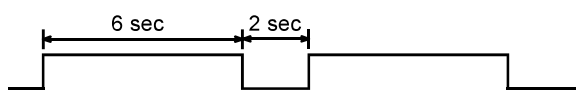
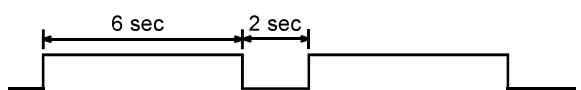
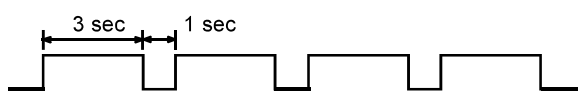
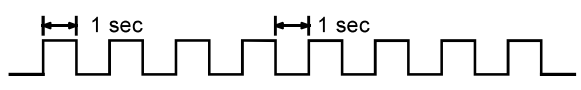





4. TROUBLESHOOTING

4-1 NORMAL OPERATION

4-1-1 Indoor Unit Display

Indication type	Indication Lamp	Flashing Pattern
Operation	Operation LED	Continuous lighting
Anti Freeze		Continuous lighting(lowered light)
Timer	Timer LED	Continuous lighting(lowered light)
Filter	Filter LED	Continuous lighting
Power Failure	Operation LED	ON OFF 
	Timer LED	ON OFF 
Test Operation	Operation LED	ON OFF 
	Timer LED	ON OFF 
Defrosting	Operation LED	ON OFF 
Oil Recovery		ON OFF 
Opposite Operation Mode	Timer LED	ON OFF 
Maintenance Mode	Operation LED	ON OFF 
	Timer LED	
	Filter LED	

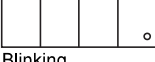
4-1-2 OUTDOOR UNIT DISPLAY

Indication type	7 Segment LED Pattern	Description
Idling(stop)	 Blank	
Cooling Mode	 "C" "OO" "L"	
Heating Mode	 "H" "EA" "T"	
Oil Recovery Operation	 "O" "IL" "R" "ECOVERY"	Refer to 02-10 page for operation.
Defrost Operation	 "D" "E" "F" "ROST"	Refer to 02-11 page for operation.
System stooped with Discharge Temp. Protection	 "P" "ROTECT" "1"	<Starting condition> Discharge temp \geq fixed value: 115°C <Release condition> 3 minutes have elapsed and discharge temperature \leq 80°C
System stopped with High Pressure Protection	 "P" "ROTECT" "2"	<Starting condition> High pressure \geq 4.00MPa <Release condition> 5 minutes have elapsed and high pressure \leq 3.50MPa
System stopped with Low Pressure Protection	 "P" "ROTECT" "3"	<Starting condition> Low pressure \leq 0.05MPa or low pressure \leq 0.10MPa continues for 10 minutes <Release condition> 3 minutes have elapsed and low pressure \geq 0.17MPa
System stopped with compressor Temperature Protection	 "P" "ROTECT" "4"	<Starting condition> Compressor temp \geq fixed value :110°C <Release condition> 3 minutes have elapsed and discharge temperature \leq 80°C
Peak Cut Mode	 "P" "eak" "C" "ut"	
Low Noise Mode	 "L" "OW" "N" "OISE"	Refer to 02-08 page for operation.
Inverter Compressor Operation Indication	 Blinking	ON  OFF 

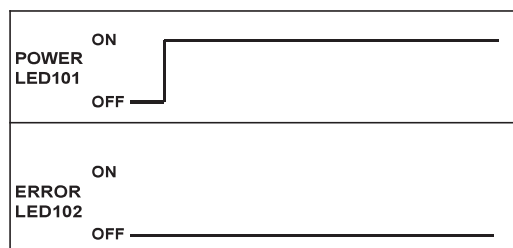
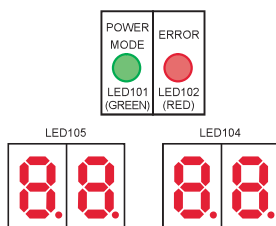

4-2 ABNORMAL OPERATION

4-2-1 Indoor Unit Display

Please refer the flashing pattern as follows.

Error Contents	Operation LED	Timer LED	Filter LED	Trouble shooting
Remote Controller Communication Error	1 times flash	2 times flash	Continuous flash	9
Network Communication Error	1 times flash	4 times flash	Continuous flash	11
Indoor Unit Parallel Communication Error	1 times flash	6 times flash	Continuous flash	10
Indoor Unit Power Frequency Abnormal	3 times flash	1 times flash	Continuous flash	2
Indoor Unit Main PCB Error	3 times flash	2 times flash	Continuous flash	1,3
Room Temperature Sensor Error	4 times flash	1 times flash	Continuous flash	4
Indoor Unit Heat Ex. Sensor Error	4 times flash	2 times flash </td <td>Continuous flash</td> <td>5,6</td>	Continuous flash	5,6
Indoor Unit Fan Motor Error	5 times flash	1 times flash	Continuous flash	8
Water Drain Abnormal	5 times flash	3 times flash	Continuous flash	7
Outdoor Unit Error	9 times flash	15 times flash	Continuous flash	12 ~ 48

Depending on contents of Outdoor unit, it may not indicate. (Refer to "TROUBLE LEVEL OF SYSTEM")

Error Indication Flashing Pattern

Example : Indoor Unit Main PCB Error (Operation LED : 3 times, Timer LED : 2 times)

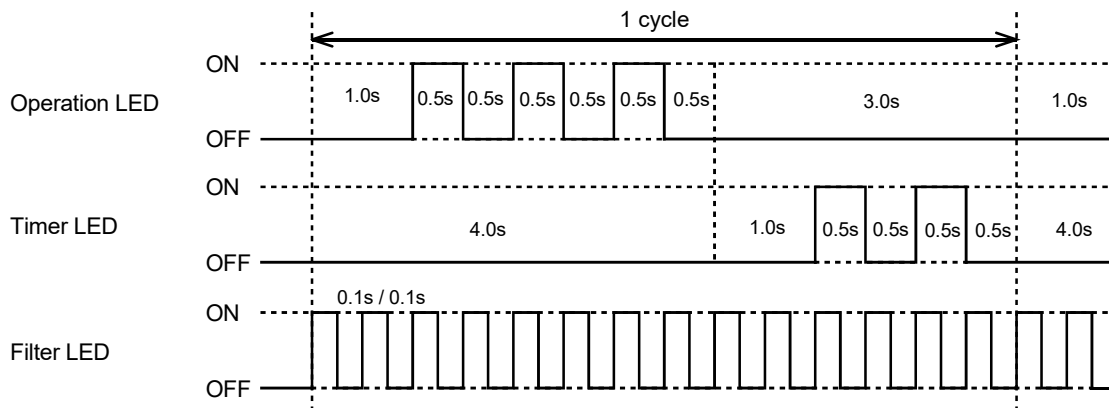

Outdoor Air Unit

Error Contents	Error code		Operation LED	Timer LED	Filter LED	Trouble shooting
	Large division	Small division				
Indoor unit power supply error for fan motor 1	3 9	1	3 times flash	9 times flash	Continuous flash	100
Indoor unit power supply error for fan motor 2	3 9	2	3 times flash	9 times flash	Continuous flash	
Indoor unit suction air temp. thermistor error	4 A	1	4 times flash	10 times flash	Continuous flash	101
Indoor unit discharge air temp. thermistor error	4 A	2	4 times flash	10 times flash	Continuous flash	102
Indoor unit fan motor 2 rotation error	5 9	2	5 times flash	9 times flash	Continuous flash	103
No power	-	-	-	-	-	104

* LED Display when Option receiver unit installed.

Error Contents	Error code	Trouble shooting
Remote controller communication error	1 2	9
Network communication error	1 4	11
Peripheral unit communication error	1 6	10
Indoor unit address setting error	2 6	86
Connection unit number error in WRC system	2 9	105
Indoor unit power supply abnormal	3 1	2
Indoor unit main PCB error	3 2	1, 3
Indoor unit (Communication circuit) WRC error	3 A	106
Indoor unit heat ex. temp. thermistor error	4 2	5, 6
Indoor unit air temp. thermistor error	4 A	101, 102
Indoor unit coil 1 (Expansionvalve) error	5 2	107
Indoor unit coil 2 (Expansionvalve) error	5 2	108
Indoor unit water drain abnormal	5 3	7
Outdoor unit miscellaneous error	9 U	12~ 48
DX-Kit Error	J 6	109
No Error Code		Trouble shooting
Peripheral device - No Power		110
Peripheral device - FAN does not operate		111
Peripheral device - No cooling/ No Heating		112
DX Kit No Power		113

4-2-2 Outdoor Unit Display

LED display

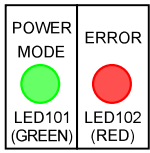

POWER MODE LED : on
ERROR LED : blink

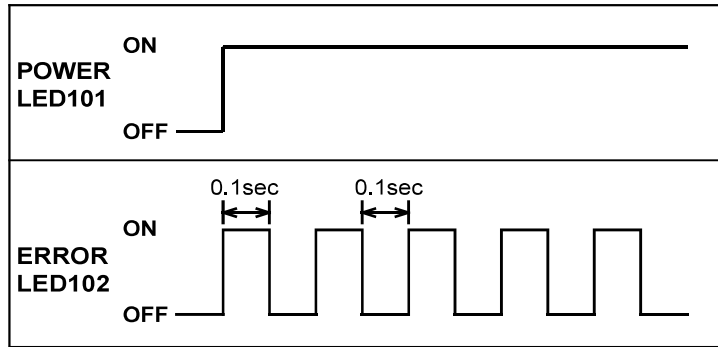

Operation button

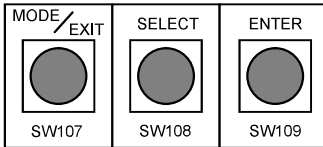

ERROR transition

Short press : less than 3 seconds
Long press : more than 3 seconds

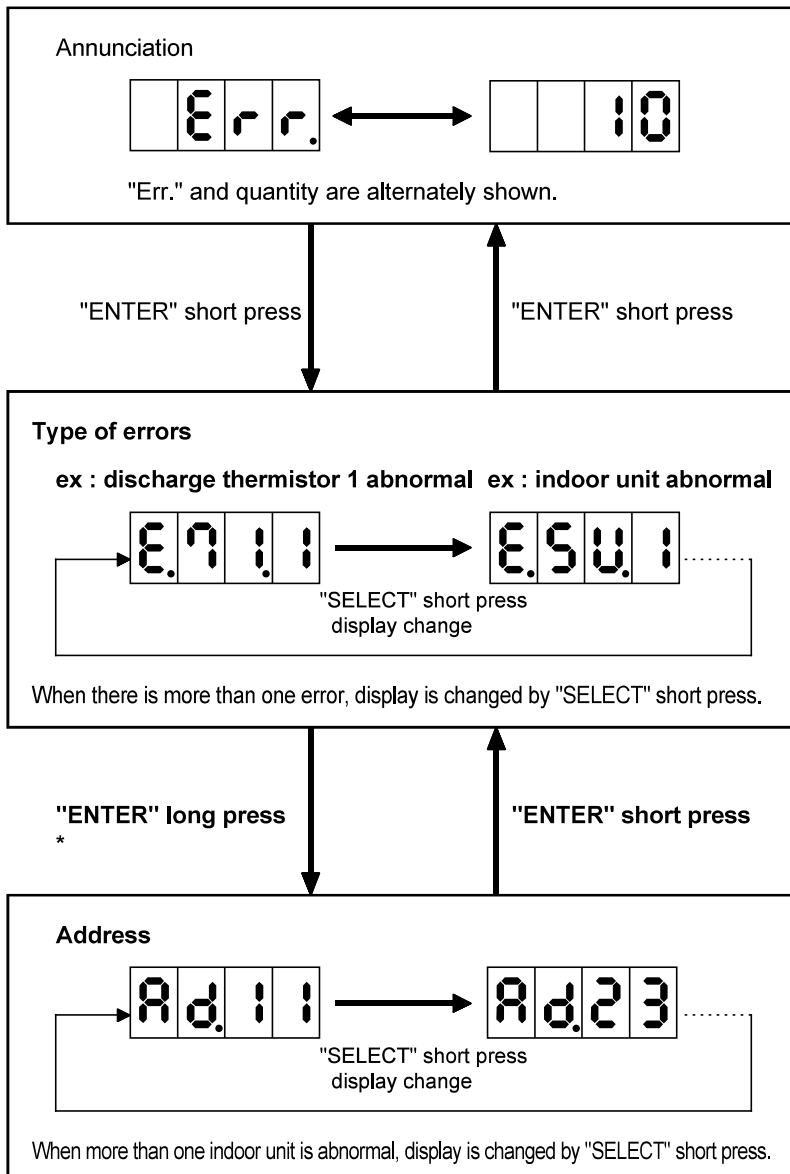

If some error is newly occurred or resolved during transition, it is reflected after going back to "Annunciation".

* Only in the case of "indoor unit abnormal (E.5U.1)", indoor unit address is shown by ENTER long press.

4-2-3 Error Code List for Outdoor Unit

Error Code	Error Contents	Trouble shooting
- - - -	Initial Setting Error	12
1 4.2	Outdoor unit Network communication abnormal 2	14
1 4.5	The number of Indoor unit shortage	48
2 8.1	Auto Address Setting Error	46
2 8.4	Signal Amplifier Auto Address Setting Error	47
5 U.1	Indoor Unit Error	1 - 11
6 2.3	Outdoor Unit EEPROM Access Error	15
6 2.6	Inverter Communication Error	16
6 2.8	EEPROM Data corrupted Error	17
6 3.1	Inverter Error	18
6 7.2	Inverter PCB short intereuption detection	19
6 9.1	Outdoor Unit transmission PCB Parallel Communication Error	20
7 1.1	Discharge Temp. Sensor Error < TH1 >	21
7 2.1	Compressor Temp. Sensor Error < TH10 >	22
7 3.3	Heat Ex. Liquid pipe Temp. Sensor Error < TH5 >	23
7 4.1	Outdoor Temp. Sensor Error < TH3 >	24
7 5.1	Suction Gas Temp. Sensor Error < TH4 >	25
7 7.1	Heat Sink Temp. Sensor Error < IPM built in >	26
8 2.1	SC HE. Gas Inlet Temp. Sensor Error < TH8 >	27
8 2.2	SC HE. Gas Outlet Temp. Sensor Error < TH9 >	28
8 3.2	SC HE. Liquid Outlet Temp Sensor Error < TH7 >	29
8 4.1	Current Sensor Error	30
8 6.1	Discharge Pressure Sensor Error	31
8 6.3	Suction Pressure Sensor Error	32
8 6.4	High Pressure Switch Error	33

Error Code	Error Contents	Trouble shooting
9 3.1	Inverter Compressor Start Up Error	34
9 4.1	Trip Detection	35
9 5.5	Compressor Motor Loss of Synchronization	36
9 7.1	Outdoor Unit Fan Motor Lock Error (Start up Error)	37
9 7.4	Outdoor unit FAN motor under voltage (Lack of DC Voltage)	38
9 7.5	Outdoor Unit Fan Motor 1 Temperature Abnormal	39
9 8.1	Outdoor Unit Fan Motor Lock Error (Start up Error)	37
9 8.5	Outdoor Unit Fan Motor 2 Temperature Abnormal	39
9 A.1	Coil (Expansion Valve 1) Error	40
9 A.2	Coil (Expansion Valve 2) Error	40
A 1.1	Discharge Temperature Abnormal	41
A 3.1	Compressor Temperature Abnormal	42
A 4.1	High Pressure Abnormal	43
A 4.2	High Pressure Protection 1	44
A 5.1	Low Pressure Abnormal	45
A C.4	Outdoor unit Heat Sink temp. Abnormal	45-1

4-2-4 Remote Controller Display

<< SIMPLE REMOTE CONTROLLER >>

ERROR CODE DISPLAY

If an error occurs, the following display will be shown.
 ("Er" will appear in the set room temperature display.)
 If "Er" is displayed, immediately contact authorized service personnel.

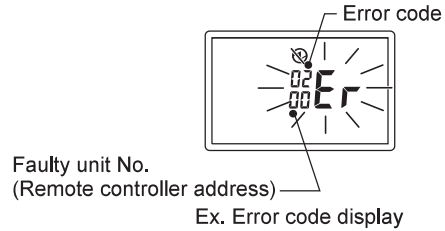

<< WIRED REMOTE CONTROLLER >>

ERROR CODE DISPLAY

If an error occurs, the following display will be shown.
 ("Er" will appear in the set room temperature display.)
 If "Er" is displayed, immediately contact authorized service personnel.

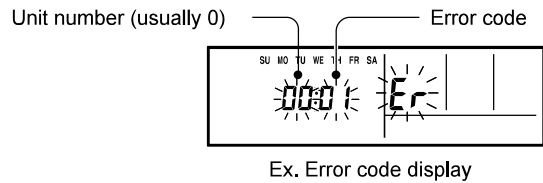

<< GROUP REMOTE CONTROLLER >>

ERROR CODE DISPLAY

The air conditioning system must be inspected if "E : " (error code) appears on the timer and Clock Display, or the operation lamp is flashing.

*1 ; Model code
 □ : Outdoor unit
 † : Indoor unit
 ⌈ : Group remote controller
 R : Converter

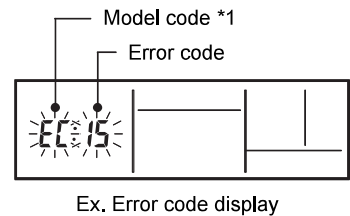

4-2-5 Error Code List for Simple and Wired Remote Controller

Error Code	Error Contents	Trouble shooting
1 2	Remote Controller Communication Error	9, 83
1 4	Network Communication Error	11
1 5	Scan Error	84
1 6	Indoor Unit Parallel Communication Error	10
3 1	Indoor Unit Power Frequency Abnormal	2
3 2	Indoor Unit Main PCB Error	1, 3

Error Code	Error Contents	Trouble shooting
4 1	Room Temperature Sensor Error	4
4 2	Indoor Unit Heat Ex. Sensor Error	5, 6
5 1	Indoor Unit Fan Motor Error	8
5 3	Water Drain Abnormal	7
9 U	Outdoor Unit Error	12 ~ 48

4-2-6 Error Code List for Group Remote Controller

Error Code	Error Contents	Trouble shooting
- -	Initial Setting Error	12
1 2	Remote Controller Communication Error	9,10,72,78
1 4	Network Communication Error	11,13,14,81
1 5	Scan Error	84
1 6	Indoor Unit Parallel Communication Error	10
2 6	Address Setting Error	79
2 8	Other Setting Error	46, 47
3 1	Indoor Unit Power Frequency Abnormal	2
3 2	Indoor Unit Main PCB Error	1, 3
4 1	Room Temperature Sensor Error	4
4 2	Indoor Unit Heat Ex. Sensor Error	5, 6
5 1	Indoor Unit Fan Motor Error	8
5 3	Water Drain Abnormal	7
6 2	Outdoor Unit Main PCB Error	15 ~ 17
6 3	Inverter Error	18
6 7	Inverter PCB short interruption detection	19
6 9	Outdoor Unit transmission PCB Error	20
7 1	Discharge Temperature Sensor Error	21
7 2	Compressor Temperature Sensor Error	22
7 3	Heat Ex. liquid pipe Temperature Sensor Error	23
7 4	Outdoor Temperature Sensor Error	24
7 5	Suction Gas Temperature Sensor Error	25
7 7	Heat Sink Temperature Sensor Error	26

Error Code	Error Contents	Trouble shooting
8 2	Sub-cool Heat Ex. Gas Temperature Sensor Error	27,28
8 3	Liquid Pipe Temperature Sensor Error	29
8 4	Current Sensor Error	30
8 6	Pressure Sensor Error	31 ~ 33
9 3	Compressor Start Up Error	34
9 4	Trip Detection	35
9 5	Compressor Motor loss of Synchronization	36
9 7	Outdoor Unit Fan Motor 1 Error	37 ~ 39
9 8	Outdoor Unit Fan Motor 2 Error	37 ~ 39
9 A	Coil (Expansion Valve) Error	40
A 1	Discharge Temperature Abnormal	41
A 3	Compressor Temperature Abnormal	42
A 4	High Pressure Abnormal	43, 44
A 5	Low Pressure Abnormal	45
A C	Outdoor unit Heat Sink temp. Abnormal	45-1
C 4	PCB Error	77
C A	Software Error	68, 75
C 1	PCB Error 1	66, 71

4-2-7 Error Code List for External Switch Controller (UTY-TEKX)

Error Code	Error Contents	Trouble shooting
- -	Power Supply Error	55
- -	The abnormality in connection of remote controller cable	56
- -	Transmission Error	57
- -	Switch Operation Error	58

4-2-8 Error Code List for Signal Amplifier (UTY-VSGX)

Error Code	Error Contents	Trouble shooting
- -	Power Supply Error	59
- -	Communication Error	60
2 6	Address Setting Error	61
C 1	Parallel Communication Error	62
- -	Communication Error B	63
- -	Communication Error A	64

4-2-9 Error Code List for Network Convertor (UTY-VGGX)

1. When connecting a group remote controller to a network convertor

Error Code	Error Contents	Trouble shooting
- -	Power Supply Error	65
C 1	PCB Error 1	66
1 2	Communication Error with Group Remote Controller	67
C A	Software Error	68
2 6	Refrigerant circuit address setting error	69

2. When connecting a single split type indoor unit to a network convertor

Error Code	Error Contents	Trouble shooting
- -	Power Supply Error	70
C 1	PCB Error 1	71
1 2	Communication Error with Standard Remote Controller	72
1 6	Communication Error with Indoor Unit	73
2 6	Communication Error with Indoor Unit	74
C A	Software Error	75
5 U	Indoor / Outdoor Unit Error	76

4-2-10 TROUBLE LEVEL OF SYSTEM

<< System Condition when Outdoor Unit Error is occurred >>

System Condition	Outdoor unit Condition	Trouble Level	
		1	2
		(1) Not indicated on Indoor Unit. Not indicated on Peripheral Unit. Indicated on Service Tool.	(2) ● Indicated on Indoor Unit. Indicated on Peripheral. Indicated on Service Tool.
System is not stopped compulsorily	>Abnormal >LED indication >Outdoor unit does not stop	(Not available)	> Suction gas Temp sensor error > Outdoor Temp sensor error > Sub-cool heat Ex. gas inlet Temp sensor error > Sub-cool heat Ex. gas outlet Temp sensor error
	>Abnormal >LED indication >Outdoor unit does not stop	>Temporary blackout detection protection (Inverter compressor stop)	> Discharge temperature abnormal (Inverter compressor stops) > Compressor temperature abnormal (Inverter compressor stops) > High pressure switch error (Inverter compressor stops) > High pressure switch error (Constant speed compressor stops) > Discharge Temp sensor error (Inverter compressor stops) > Compressor Temp sensor error (Inverter compressor stop) > Heat sink Temp sensor error (Inverter compressor stop) > Current sensor error (Inverter compressor stop) > High pressure switch error (Inverter compressor stop) > Inverter error (Inverter compressor stop) > Heat sink temperature abnormal (Inverter compressor stop) > Inverter compressor start up error (Inverter compressor stop) > Trip detection (Inverter compressor stops) > Rush current limiting resistor Temp rise protection (Inverter compressor stop) > Comp. motor loss of synchronization (Inverter compressor stop) > Inverter communication error (Inverter compressor stop) > Outdoor unit EEPROM access error > Outdoor unit EEPROM data corrupted > Indoor unit number shortage

● This will not be displayed on indoor unit which Error Report Target(function setting 47 of indoor unit) is set "for administrator".

System Condition	Outdoor unit Condition	Trouble Level	
		1	2
		(1) Not indicated on Indoor Unit. Not indicated on Peripheral Unit. Indicated on Service Tool.	(2) Indicated on Indoor Unit. Indicated on Peripheral. Indicated on Service Tool.
System is compulsorily stopped.	<ul style="list-style-type: none"> >Abnormal >LED indication >Outdoor unit stops >Need to repair >secondary accident is possible. 	(Not available)	<ul style="list-style-type: none"> >High pressure abnormal >Low pressure abnormal >Fan motor 1 lock error >Fan motor 2 lock error >Fan motor 1 temp. abnormal >Fan motor 2 temp. abnormal >Heat Ex. liquid Temp sensor error >Discharge pressure sensor error >Suction pressure sensor error >Outdoor unit communication PCB parallel communication error >Outdoor unit network communication 2 error >Lack of DC Voltage >Indoor unit number shortage >SC HE. Liquid Outlet Temp Sensor Error

<Important>

Even if power is reset, the following Error cannot release.

- Discharge temperature abnormal
- Compressor temperature abnormal
- Current sensor error
- Inverter compressor start up error
- Trip detection
- Rush current limiting resistor Temp rise protection
- Comp. motor loss of synchronization
- Low pressure abnormal
- Fan motor 1 lock error
- Fan motor 2 lock error

These errors can not be judged without operating the system, and the serviceman would not be able to check it if the system power is turned off before visiting the site for repair. In Error release, you need to operate push switch and apply "Error reset" (F3-40) after power restart.

4-2-11 ERROR HISTORY MODE

When the abnormality occurred, the J2 system memorizes the history of error codes up to 10 and it can be displayed on 7 segments LED. It is an effective means to examine abnormality that occurred in the past.

*The error history can be cleared by setting to F3-30.

Refer to the following for the procedure.

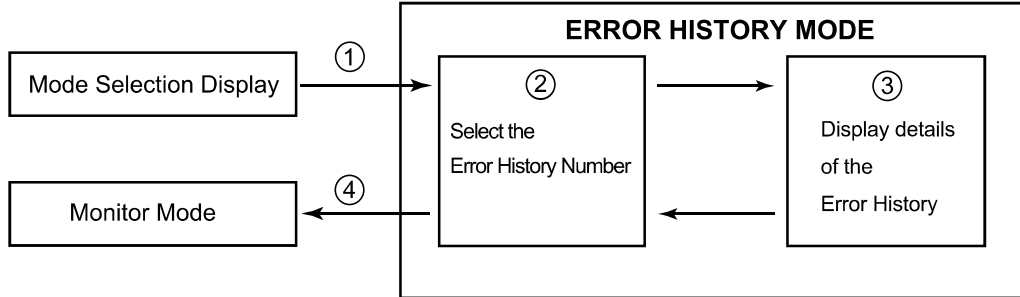

① Change to the Error History Mode from the Mode Selection Display

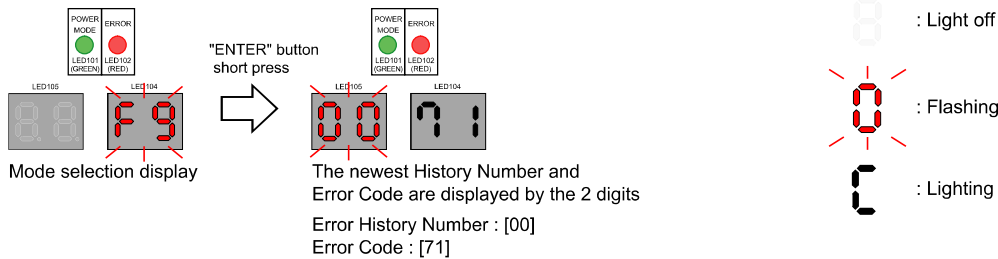

② Select the Error History Number

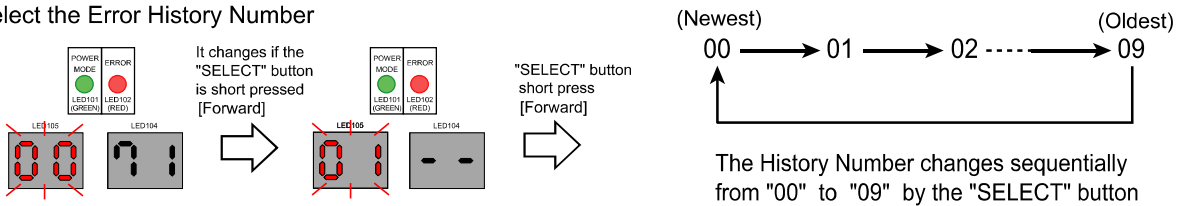

③ Check the detail of the Error History

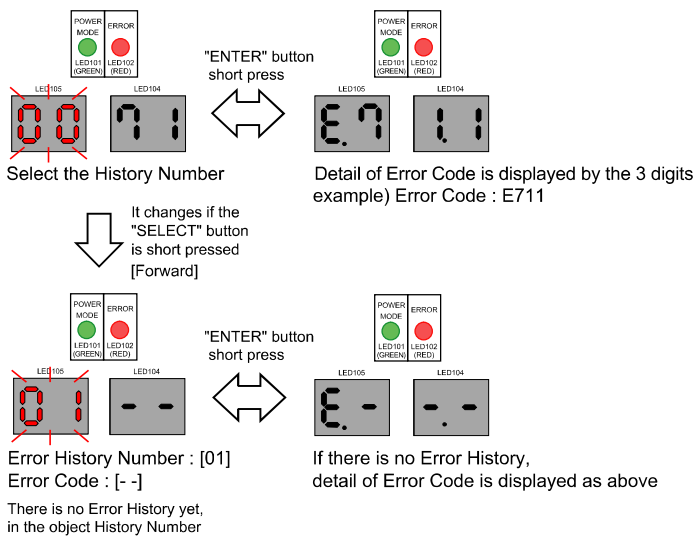

④ End of the Error History mode

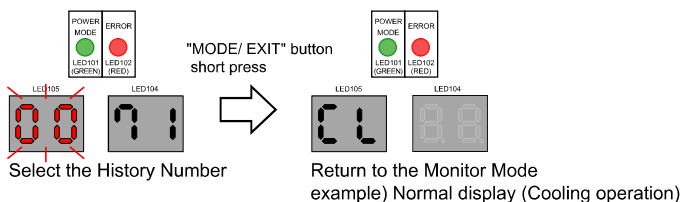

Trouble shooting 2 INDOOR UNIT Error Method: Power Frequency Abnormal	Indicate or Display: Outdoor Unit : E.5 U.1 Indoor Unit : Operation LED 3 times Flash, Timer LED 1 Times Flash, Filter LED Continuous Flash. Error Code : 3 1
--	--

Detective Actuators: Indoor Unit Controller PCB Circuit	Detective details: When 5 continuous failures occurred at Power frequency test.
---	---

Forecast of Cause : 1. Outside cause 2. Installation failure 3. Defective connection of electric components
4. Controller PCB defective

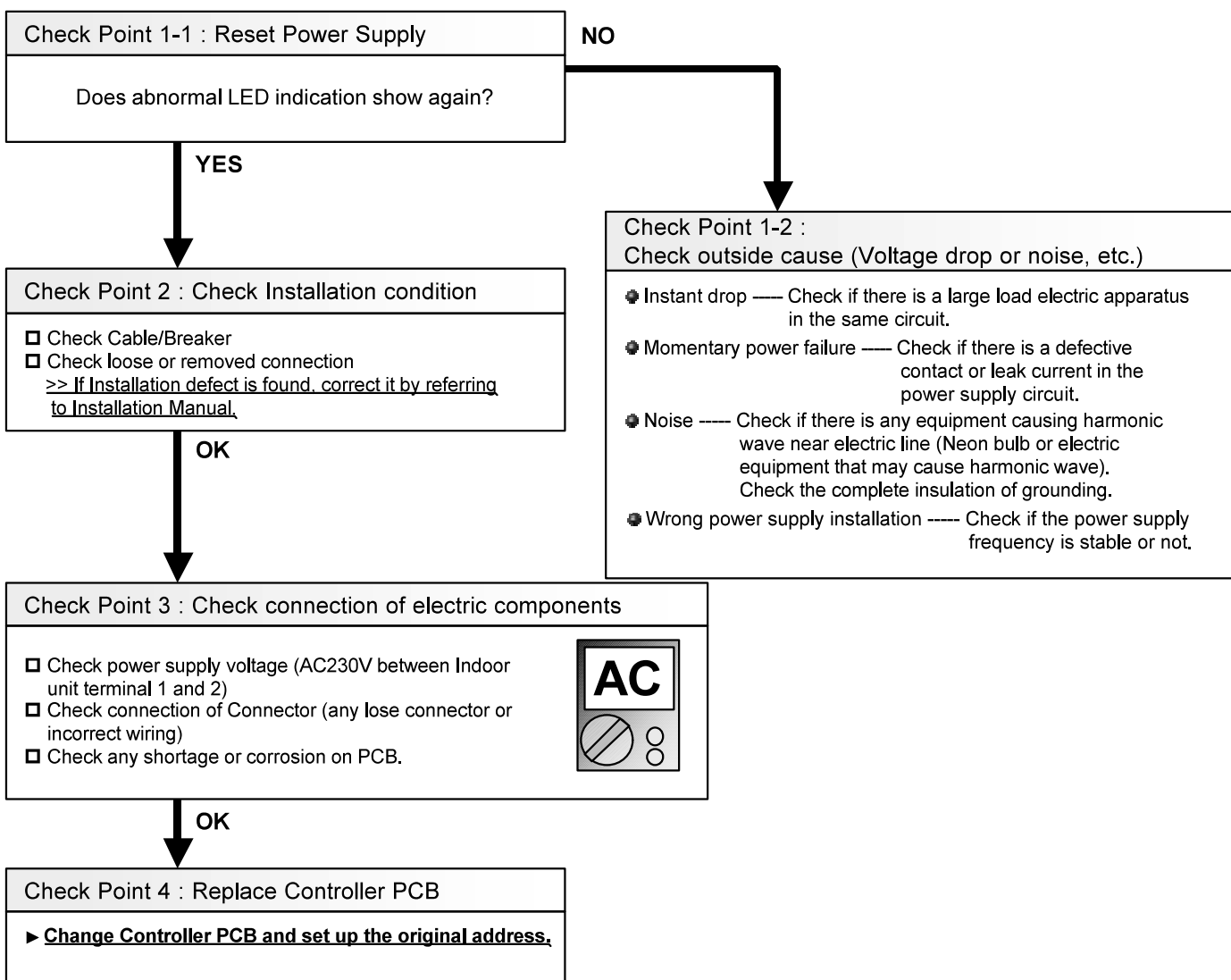

Trouble shooting 3 INDOOR UNIT Error Method: EEPROM Access Abnormal (Indoor Unit Main PCB Error)	Indicate or Display: Outdoor Unit : E.5 U.1 Indoor Unit : Operation LED 3 times Flash, Timer LED 2 Times Flash, Filter LED Continuous Flash. Error Code : 3 2
---	--

Detective Actuators: Indoor Unit Controller PCB Circuit	Detective details: When 3 continuous failure occurred on read test of EEPROM.
---	---

Forecast of Cause : 1. Outside cause 2. Defective connection of electric component 3. Controller PCB defective

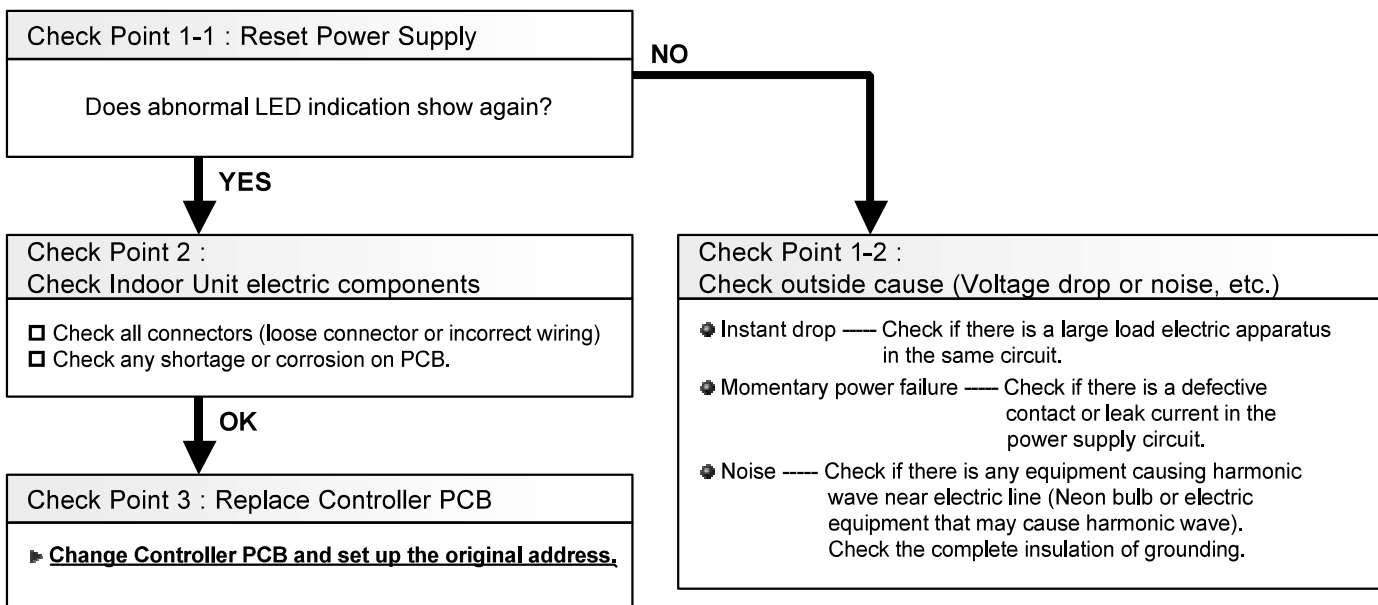

Trouble shooting 4 INDOOR UNIT Error Method: Room Temperature Sensor Error	Indicate or Display: Outdoor Unit : E.5 U.1 Indoor Unit : Operation LED 4 times Flash, Timer LED 1 Times Flash, Filter LED Continuous Flash. Error Code : 4 1

Detective Actuators: Indoor Unit Controller PCB Circuit Indoor Temperature Thermistor	Detective details: When Indoor thermistor open or shortage is detected at power ON.
--	---

Forecast of Cause : 1. Connector defective connection 2. Thermistor defective 3. Controller PCB defective

Check Point 1 : Check connection of Connector

- Check if connector is loose or removed
- Check erroneous connection
- Check if thermistor cable is open

>>Reset Power when reinstalling due to removed connector or incorrect wiring.



Check Point 2 : Remove connector and check Thermistor resistance value

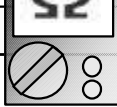

Thermistor Characteristics (Rough value)

Temperature (°C)	0	5	10	15	20	25	30	35
Resistance Value (kΩ)	33.6	25.2	20.1	15.8	12.5	10.0	8.0	6.5

Temperature (°C)	40	45	50
Resistance Value (kΩ)	5.3	4.3	3.5

► If Thermistor is either open or shorted, replace it and reset the power.



Check Point 3 : Check voltage of Controller PCB (DC5.0V)

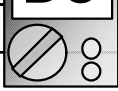

Make sure circuit diagram of each indoor unit and check terminal voltage at Thermistor (DC5.0V)

- Duct Schematic Diagram (Connector connection)
- Small size Wall mount Schematic Diagram(Direct soldering to PCB)

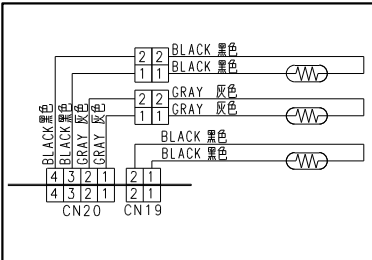

H/E Inlet Thermistor (CN20 Wire:Black)

H/E Outlet Thermistor (CN20 Wire:Gray)

Room Temp. Thermistor (CN19 Wire:Black)

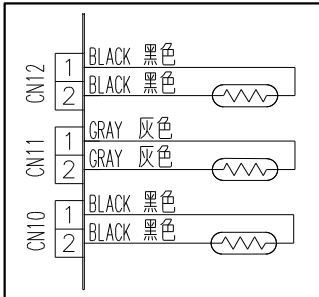

H/E Inlet Thermistor (CN12 Wire:Black)

H/E Outlet Thermistor (CN11 Wire:Gray)

Room Temp. Thermistor (CN10 Wire:Black)

- Cassette Schematic Diagram (Connector connection)
- Wall mount Schematic Diagram (Connector connection)

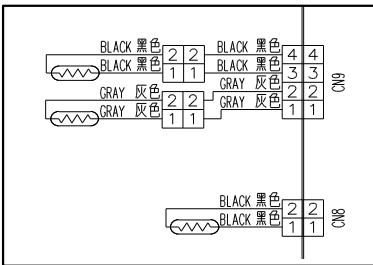

H/E Inlet Thermistor (CN9 Wire:Black)

H/E Outlet Thermistor (CN9 Wire:Gray)

Room Temp. Thermistor (CN8 Wire:Black)

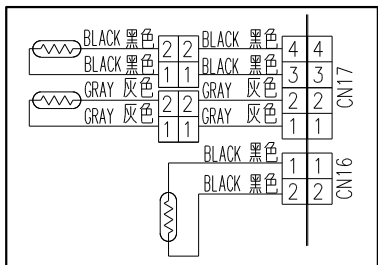

H/E Inlet Thermistor (CN17 Wire:Black)

H/E Outlet Thermistor (CN17 Wire:Gray)

Room Temp. Thermistor (CN16 Wire:Black)

► If the voltage does not appear, replace Controller PCB and set up the original address.

Trouble shooting 5 INDOOR UNIT Error Method: Heat Exchanger Inlet Sensor Error	Indicate or Display: Outdoor Unit : E.5 U.1 Indoor Unit : Operation LED 4 times Flash, Timer LED 2 Times Flash, Filter LED Continuous Flash. Error Code : 4 2
	Detective Actuators: Indoor Unit Controller PCB Circuit Heat Exchanger Inlet Thermistor

Detective details: When open or shorted Heat Exchanger Inlet Thermistor is detected at Power ON.
--

Forecast of Cause : 1. Connector defective connection 2. Thermistor defective 3. Controller PCB defective

Check Point 1 : Check connection of Connector

Check if connector is loose or removed
 Check erroneous connection
 Check if thermistor cable is open
>>Reset Power when reinstalling due to removed connector or incorrect wiring.



Check Point 2 : Remove connector and check Thermistor resistance value

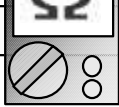

Thermistor Characteristics (Rough value)

Temperature (°C)	0	5	10	15	20	25	30	35
Resistance Value (kΩ)	168.6	129.8	100.9	79.1	62.5	49.8	40.0	32.4

Temperature (°C)	40	45	50
Resistance Value (kΩ)	26.3	21.2	17.8

► **If Thermistor is either open or shorted, replace it and reset the power.**



Check Point 3 : Check voltage of Controller PCB (DC5.0V)

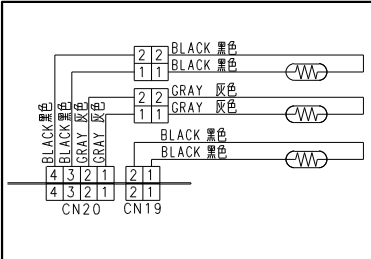
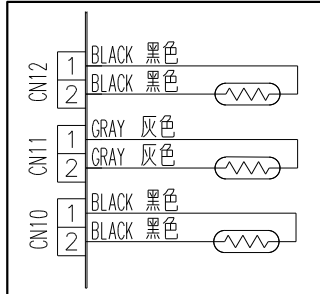
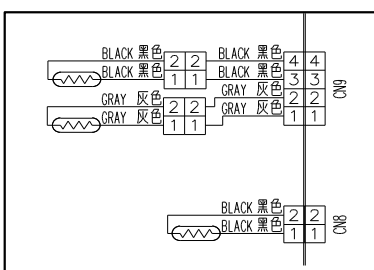
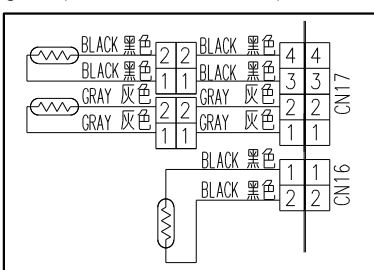

Make sure circuit diagram of each indoor unit and check terminal voltage at Thermistor (DC5.0V)

- Duct Schematic Diagram (Connector connection)
 - H/E Inlet Thermistor (CN20 Wire:Black)
 - H/E Outlet Thermistor (CN20 Wire:Gray)
 - Room Temp. Thermistor (CN19 Wire:Black)
- Small size Wall mount Schematic Diagram(Direct soldering to PCB)
 - H/E Inlet Thermistor (CN12 Wire:Black)
 - H/E Outlet Thermistor (CN11 Wire:Gray)
 - Room Temp. Thermistor (CN10 Wire:Black)
- Cassette Schematic Diagram (Connector connection)
 - H/E Inlet Thermistor (CN9 Wire:Black)
 - H/E Outlet Thermistor (CN9 Wire:Gray)
 - Room Temp. Thermistor (CN8 Wire:Black)
- Wall mount Schematic Diagram (Connector connection)
 - H/E Inlet Thermistor (CN17 Wire:Black)
 - H/E Outlet Thermistor (CN17 Wire:Gray)
 - Room Temp. Thermistor (CN16 Wire:Black)

► **If the voltage does not appear, replace Controller PCB and set up the original address.**

Trouble shooting 6
INDOOR UNIT Error Method:
Heat Exchanger Outlet Sensor Error

Indicate or Display:
 Outdoor Unit : E.5 U.1
 Indoor Unit : Operation LED 4 times Flash, Timer LED 2 Times Flash,
 Filter LED Continuous Flash.
 Error Code : 4 2

Detective Actuators:
 Indoor Unit Controller PCB Circuit
 Heat Exchanger Outlet Thermistor

Detective details:
 When open or shorted Heat Exchanger outlet Thermistor is detected at Power ON.

Forecast of Cause : 1. Connector defective connection 2. Thermistor defective 3. Controller PCB defective

Check Point 1 : Check connection of Connector

Check if connector is loose or removed
 Check erroneous connection
 Check if thermistor cable is open
>>Reset Power when reinstalling due to removed connector or incorrect wiring.



Check Point 2 : Remove connector and check Thermistor resistance value

Thermistor Characteristics (Rough value)

Temperature (°C)	0	5	10	15	20	25	30	35
Resistance Value (kΩ)	168.6	129.8	100.9	79.1	62.5	49.8	40.0	32.4

Temperature (°C)	40	45	50
Resistance Value (kΩ)	26.3	21.2	17.8

► If Thermistor is either open or shorted, replace it and reset the power.

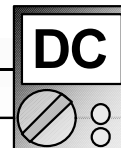

Check Point 3 : Check voltage of Controller PCB (DC5.0V)

Make sure circuit diagram of each indoor unit and check terminal voltage at Thermistor (DC5.0V)

- Duct Schematic Diagram (Connector connection)
- Small size Wall mount Schematic Diagram(Direct soldering to PCB)

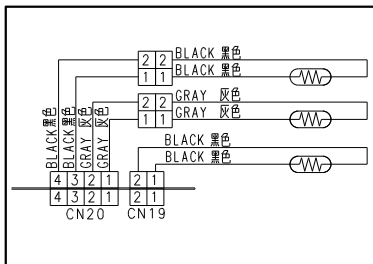

H/E Inlet Thermistor
(CN20 Wire:Black)

H/E Outlet Thermistor
(CN20 Wire:Gray)

Room Temp. Thermistor
(CN19 Wire:Black)

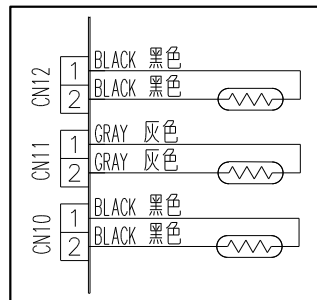

H/E Inlet Thermistor
(CN12 Wire:Black)

H/E Outlet Thermistor
(CN11 Wire:Gray)

Room Temp. Thermistor
(CN10 Wire:Black)

- Cassette Schematic Diagram (Connector connection)
- Wall mount Schematic Diagram (Connector connection)

H/E Inlet Thermistor
(CN9 Wire:Black)

H/E Outlet Thermistor
(CN9 Wire:Gray)

Room Temp. Thermistor
(CN8 Wire:Black)

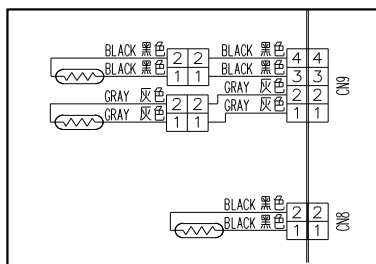

H/E Inlet Thermistor
(CN17 Wire:Black)

H/E Outlet Thermistor
(CN17 Wire:Gray)

Room Temp. Thermistor
(CN16 Wire:Black)

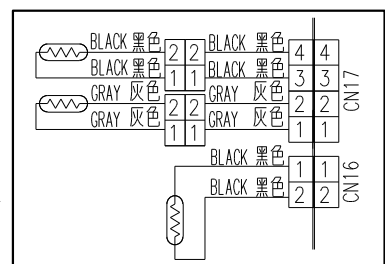

► If the voltage does not appear, replace Controller PCB and set up the original address

Trouble shooting 7 INDOOR UNIT Error Method: Water Drain Abnormal	Indicate or Display: Outdoor Unit : E.5 U.1 Indoor Unit : Operation LED 5 times Flash, Timer LED 3 Times Flash, Filter LED Continuous Flash. Error Code : 5 3
--	--

Detective Actuators: Indoor Unit Controller PCB Circuit Float Switch	Detective details: When Float switch is ON for more than 3 minutes.
---	---

Forecast of Cause : 1. Float switch defective 2. Shorted connector/wire 3. Controller PCB defective 4. Drain pump defective

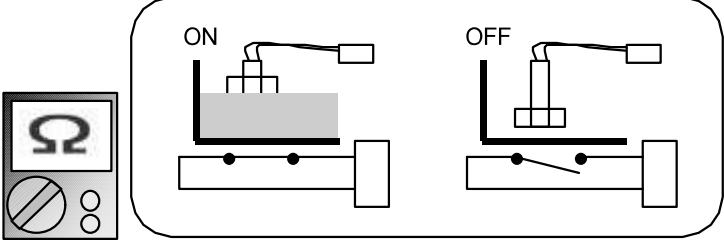
Check Point 1 : Check Float Switch	
<ul style="list-style-type: none"> ❑ Check operation of float switch. (any blocking by dust, etc.) ❑ Remove Float switch and check ON/OFF switching operation by using a meter. >>If Float switch is defective, replace it. 	

↓
OK

Check Point 2 : Check Connector (CN 1) / Wire
<ul style="list-style-type: none"> ❑ Check loose contact of CN1 /shorted wire (pinched wire). >>Replace Float switch if the wire is abnormal

↓
OK

Check Point 3 : Check Controller PCB
<ul style="list-style-type: none"> ▶ If Check Point 1 & 2 do not improve the symptom, change Controller PCB and set up the original address.

Attention!!
 Small size wall mount type does not have a float switch. In this case, replace Controller PCB and set up the original address. Please refer to.

Trouble shooting 8 INDOOR UNIT Error Method: Indoor Unit Fan Motor Error	Indicate or Display: Outdoor Unit : E.5 U.1 Indoor Unit : Operation LED 5 times Flash, Timer LED 1 Times Flash, Filter LED Continuous Flash. Error Code : 5 1
---	--

Detective Actuators: Indoor Unit Controller PCB Circuit Indoor Fan Motor	Detective details: When Indoor fan control is either phase control or DC control and rotation feed back control is ON, the feed back rotation value becomes 0 and lasts for more than 1 minute at motor operation condition. Or, the feed back rotation value continues at 1/3 of target value for more than 1 minute.
---	--

Forecast of Cause : 1. Fan rotation failure 2. Fan motor winding open 3. Motor protection by surrounding temp. increase
4. Capacitor failure 5. Control PCB failure

Check Point 1 : Check rotation of Fan

Rotate the fan by hand when operation is off.
(Check if fan is caught, dropped off or locked motor)
>>If Fan or Bearing is abnormal, replace it.



Check Point 2 : Check Motor winding

Check Indoor Fan motor
>>If Fan motor is abnormal, replace it.



Check Point 3 : Check ambient temp. around motor

Check excessively high temperature around the motor.
(If there is any surrounding equipment that causes heat)
>>Upon the temperature coming down, restart operation..



Check Point 4 : Check Motor Capacitor

Check continuity of motor capacitor
>>If it is shorted, replace the capacitor.



Check Point 5 : Replace Controller PCB

Change Controller PCB and set up the original address.

Attention!!
In case of Duct type, replace Controller PCB and set up the original address, since it is a tapping control.

Trouble shooting 9 INDOOR UNIT Error Method: Wired Remote Controller Communication Error	Indicate or Display: Outdoor Unit : E.5 U.1 Indoor Unit : Operation LED 1 times Flash, Timer LED 2 Times Flash, Filter LED Continuous Flash. Error Code : 1 2
---	--

Detective Actuators: Indoor unit controller PCB circuit Wired Remote Control	Detective details: Upon receiving the signal more than 1 time from Wired Remote or other Indoor unit, but the same signal has not been received more than 1 minute.
---	---

Forecast of Cause : 1. Terminal connection abnormal 2. Wired Remote Control failure 3. Controller PCB failure

Check Point 1 : Check the connection of terminal

After turning off the power, check & correct the followings.

Indoor Unit - Check the connection of terminal between remote control and Indoor unit, or between Indoor units, and check if there is a disconnection or short of the cable.



Check Point 2 : Check Remote and Controller PCB

Check terminal voltage of controller PCB Connector. (Power supply for Remote)
Cassette Type ⇒ CN5 , AS*E 07,09,12,14LACH / AS*A 07,09,12,14LACH Type ⇒ CN7 , Other ⇒ CN17
If DC12V, Remote Control failure (Controller PCB is OK) >>> Replace Remote
If DC0V, Controller PCB failure (Remote is OK) >>> Replace Controller PCB
▶ **In case of re-installation is done due to removed connector or incorrect wiring, turn on the power again.**



Trouble shooting 9 INDOOR UNIT Error Method: Wired Remote Controller Token Error	Indicate or Display: Indoor Unit : Operation LED 1 times Flash, Timer LED 2 Times Flash, Filter LED Continuous Flash. Outdoor Unit : E.5 U.1, Error LED Continuous Flash. Remote Controller : 1 2
---	--

Detective Actuators: Indoor unit Controller PCB circuit Wired Remote Control	Detective details: More than 1 time of Token (Communication between wired remote controllers) is received, but it was not received more than 1 minute.
---	--

Forecast of Cause : 1. Terminal connection abnormal 2. Mis-setting 3. Wired Remote Control failure 4. Controller PCB failure

Check Point 1 : Check the connection of terminal

After turning off the power, check & correct the followings.

Indoor Unit - Check the connection of terminal between remote control and Indoor unit, or between Indoor units, and check if there is a disconnection or short of the cable.



Check Point 2 : Check Remote and Controller PCB

Check terminal voltage of Controller PCB Connector. (Power supply for Remote)
Cassette Type ⇒ CN5 , AS*E 07,09,12,14LACH / AS*A 07,09,12,14LACH Type ⇒ CN7 , Other ⇒ CN17
If DC12V, Remote Control failure (Controller PCB is OK) >>> Replace Remote
If DC0V, Controller PCB failure (Remote is OK) >>> Replace Controller PCB
▶ **In case of re-installation is done due to removed connector or incorrect wiring, turn on the power again.**

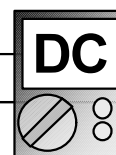

Trouble shooting 10 INDOOR UNIT Error Method: Indoor Unit Parallel Communication Error	Indicate or Display: Outdoor Unit : E.5 U.1 Indoor Unit : Operation LED 1 times Flash, Timer LED 6 Times Flash, Filter LED Continuous Flash. Error Code : 1 6
--	---

Detective Actuators: Indoor unit Controller PCB circuit Indoor unit Communication PCB	Detective details: When Parallel communication error (Communication reset occurs continuously more than specified times) is detected.
--	---

Forecast of Cause : 1. Connection failure 2. Outside cause 3. Communication PCB failure 4. Controller PCB failure

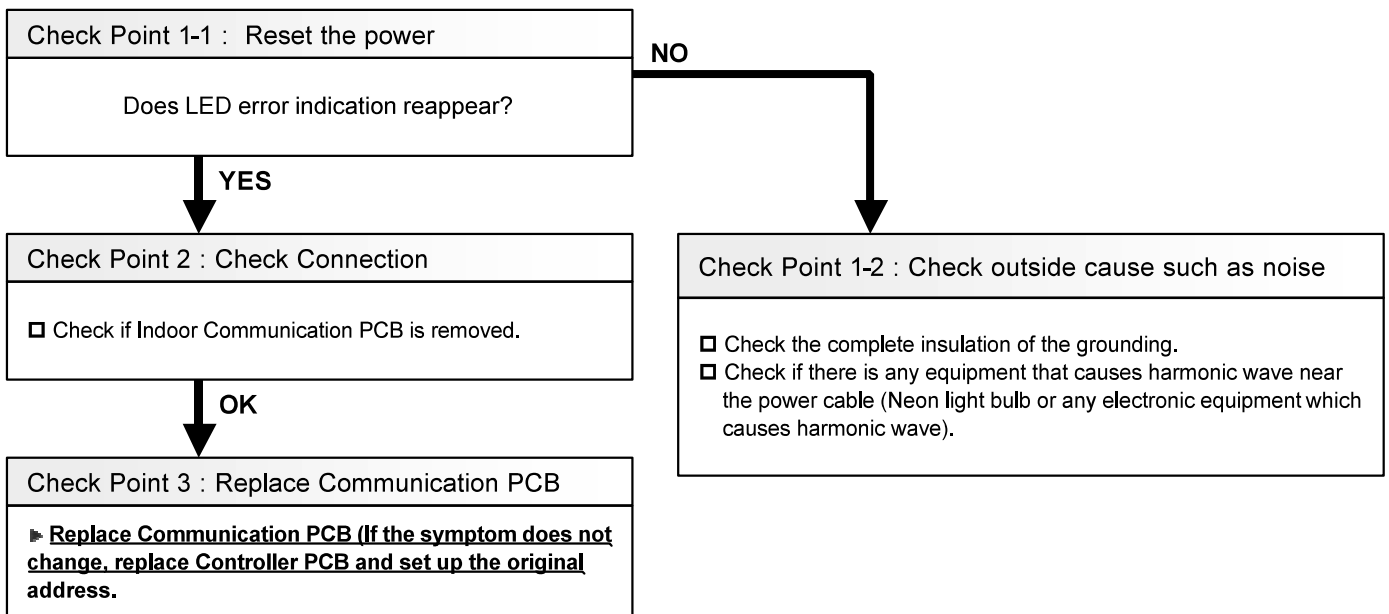

Trouble shooting 11 INDOOR UNIT Error Method: Network Communication Error	Indicate or Display: Outdoor Unit : E.5 U.1 Indoor Unit : Operation LED 1 times Flash, Timer LED 4 Times Flash, Filter LED Continuous Flash. Error Code : 1 4
--	--

Detective Actuators: Indoor unit Controller PCB circuit Indoor unit Communication PCB	Detective details: When the cut-off of network communication is detected (more than 90 seconds passed since the last receipt of Outdoor unit signal).
--	---

Forecast of Cause : 1. Connection failure 2. Outside cause 3. Communication PCB failure 4. Controller PCB failure

Check Point 1 : Check the connection
<u>After turning off the power, check and correct followings.</u> <input type="checkbox"/> Is Indoor Communication PCB loose? <input type="checkbox"/> Check loose or removed connection of communication line between Indoor and Outdoor unit. <input type="checkbox"/> When the signal amplifier is connected, is it failure of signal amplifier? (Refer to "TROUBLE SHOOTING FOR OPTIONAL PARTS")



Check Point 2 : Check if any outside cause such as voltage drop or noise
<ul style="list-style-type: none"> ● Instant voltage drop ---- Check if there is any electric equipment with a large load within the same circuit. ● Momentary power failure ---- Check contact failure or leak current in power supply circuit >>Check Outdoor Unit as well. ● Check if there is any equipment that causes harmonic wave near the power cable (Neon light bulb or any electronic equipment which causes harmonic wave). And check the complete insulation of grounding. >>If the same symptom does not reappear after resetting the power, possibility of noise is high.



Check Point 3 : Check Communication PCB and Controller PCB
<input type="checkbox"/> If some of Indoor units have errors, replace Communication PCB of the Indoor units that have the error. >>If the symptom does not change, replace Indoor unit Controller PCB. <input type="checkbox"/> If all the Indoor units have error, check if the Outdoor Unit Communication PCB has a loose connection. >>If the symptom does not change, replace Outdoor unit Communication PCB (Replace Controller PCB if it does not change).

4-3-2 Trouble Shooting With Error Code (OUTDOOR UNIT)

Trouble shooting 12 OUTDOOR UNIT Error Method: Initial Setting Error	Indicate or Display: Outdoor Unit : - - - - (Flashing 0.5 sec. ON and OFF) Indoor Unit : No Display Error Code : No Display
---	---

Detective Actuators: Outdoor unit main PCB	Detective details: When the DIP SW setting was wrong, after turned on the power supply
--	--

Forecast of Cause :	1. Wrong DIP SW setting 2. Power supply defective 3. Main PCB defective
----------------------------	---

Check Point 1 : Check the power supply
<input type="checkbox"/> Main power ON/OFF state check <input type="checkbox"/> Power cable connection, open check



Check Point 2 : Check the outdoor unit address/number of connected slave units setting						
<input type="checkbox"/> Setting check of outdoor unit address of each outdoor unit						
<table border="1" style="width: 100%; text-align: center;"> <tr> <td style="width: 33%;">Outdoor unit address</td> <td style="width: 33%;">SET 3-1</td> <td style="width: 33%;">SET 3-2</td> </tr> <tr> <td>Master</td> <td>OFF</td> <td>OFF</td> </tr> </table>	Outdoor unit address	SET 3-1	SET 3-2	Master	OFF	OFF
Outdoor unit address	SET 3-1	SET 3-2				
Master	OFF	OFF				



Check Point 3 : Replace Main PCB
<input type="checkbox"/> Change Main PCB and set up the original address.

Trouble shooting 13 OUTDOOR UNIT Error Method: Outdoor Unit Network Communication 1 Error	Indicate or Display: Outdoor Unit : E. 14. 1 Indoor Unit : No display Error Code : 14
--	--

Detective Actuators: Outdoor unit Main PCB Outdoor unit communication PCB	Detective details: • No communication for 180 seconds or more from an indoor unit which received communication once and no outdoor network communication error 2.
--	---

Forecast of Cause : 1. Noise, momentary open, voltage drop 2. Indoor unit power off 3. Communication line connection defective 4. Terminal resistor setting mistake 5. Communication PCB mounting defective, Communication PCB defective 6. Main PCB defective

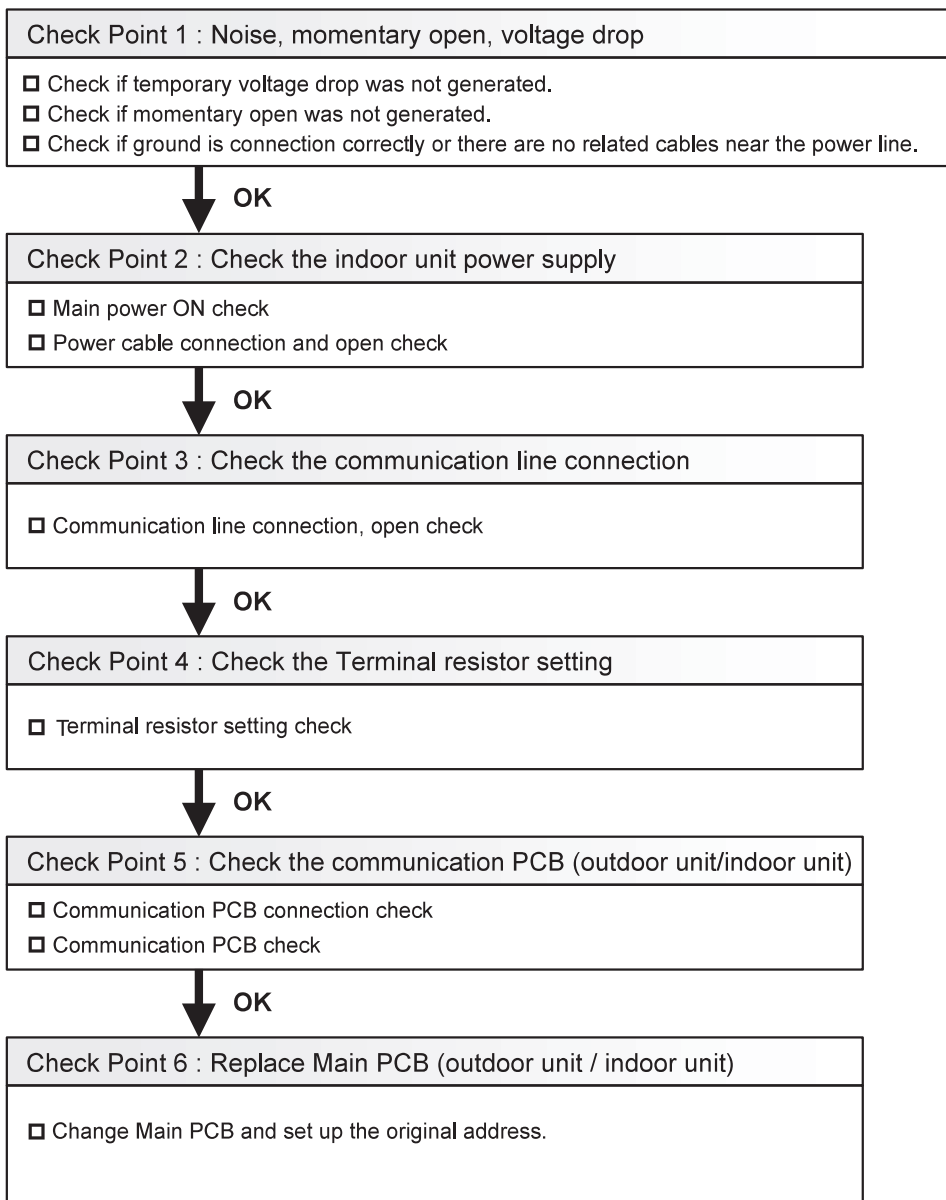

Trouble shooting 14 OUTDOOR UNIT Error Method : Outdoor Unit Network Communication 2 Error	Indicate or Display: Outdoor Unit : E. 14. 2 Indoor Unit : Operation LED 9 times Flash, Timer LED 15 Times Flash, Filter LED Continuous Flash. Error Code : 14
---	---

Detective Actuators: Outdoor unit Main PCB Outdoor unit communication PCB	Detective details: • No communication for 180 seconds or more from all indoor units that once received communication
--	--

Forecast of Cause :	1. Noise, momentary open, voltage drop 2. Indoor unit power off 3. Communication line connection defective 4. Terminal resistor setting mistake 5. Communication PCB mounting defective, Communication PCB defective 6. Main PCB defective
----------------------------	--

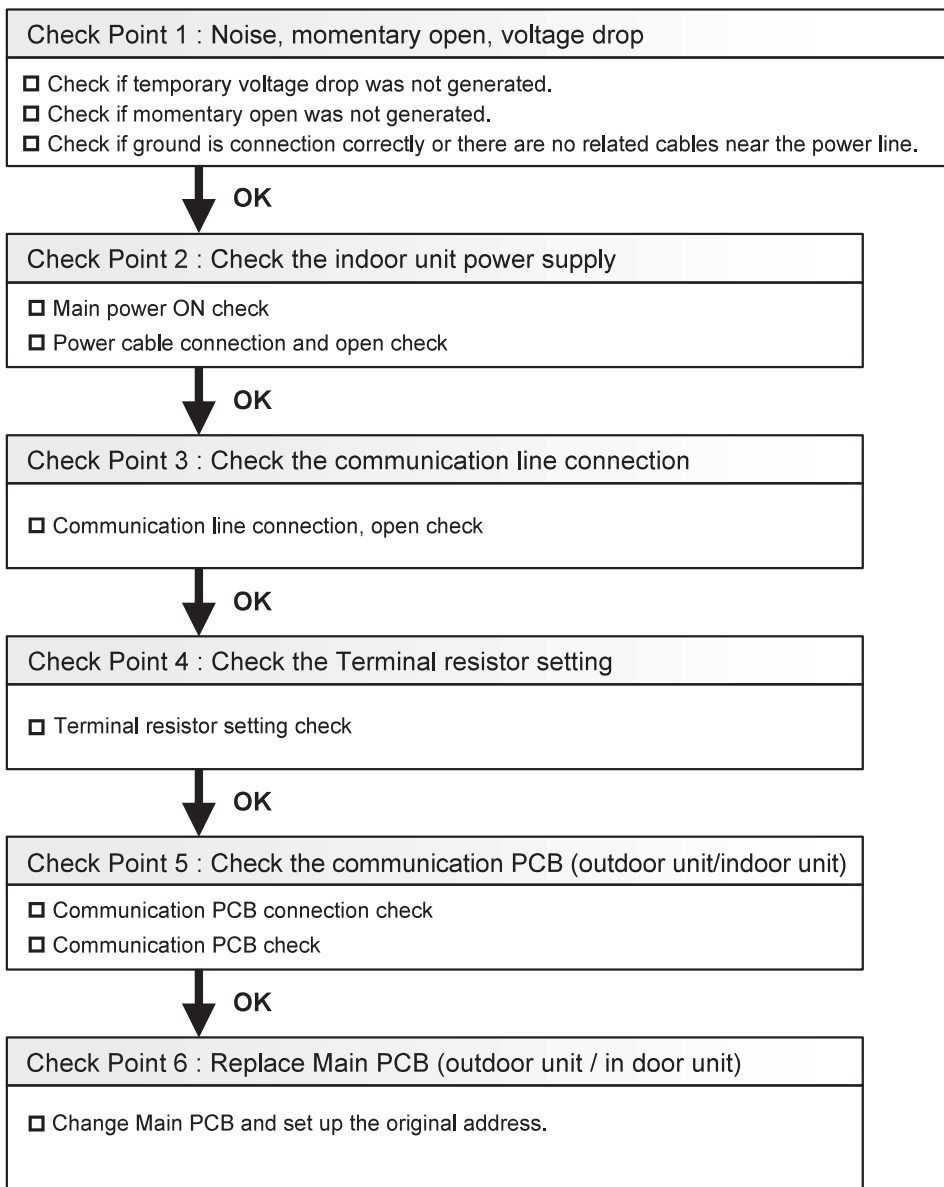

Trouble shooting 15 OUTDOOR UNIT Error Method: Outdoor Unit EEPROM Access Error	Indicate or Display: Outdoor Unit : E. 62. 3 Indoor Unit : Operation LED 9 times Flash, Timer LED 15 Times Flash, Filter LED Continuous Flash. Error Code : 62
--	---

Detective Actuators: Outdoor unit Main PCB	Detective details: •Access to EEPROM failed due to some cause after outdoor unit started.
--	---

Forecast of Cause : 1. Noise, momentary open, voltage drop 2. Main PCB defective

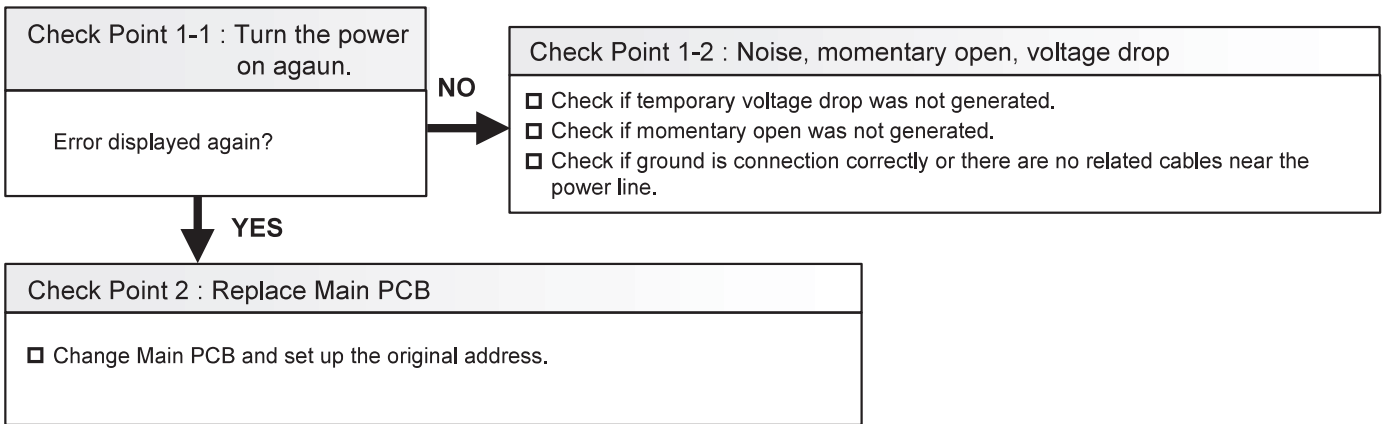

Trouble shooting 16 OUTDOOR UNIT Error Method: Inverter Communication Error	Indicate or Display: Outdoor Unit : E. 62. 6 Indoor Unit : Operation LED 9 times Flash, Timer LED 15 Times Flash, Filter LED Continuous Flash. Error Code : 62
--	---

Detective Actuators: Outdoor unit Main PCB Outdoor unit Inverter PCB	Detective details: •Communication not received from Inverter PCB for 10 seconds or more
---	---

Forecast of Cause : 1. Noise 2. Main to Inverter PCBs wiring connection defective
3. Main PCB defective 4. Inverter PCB defective

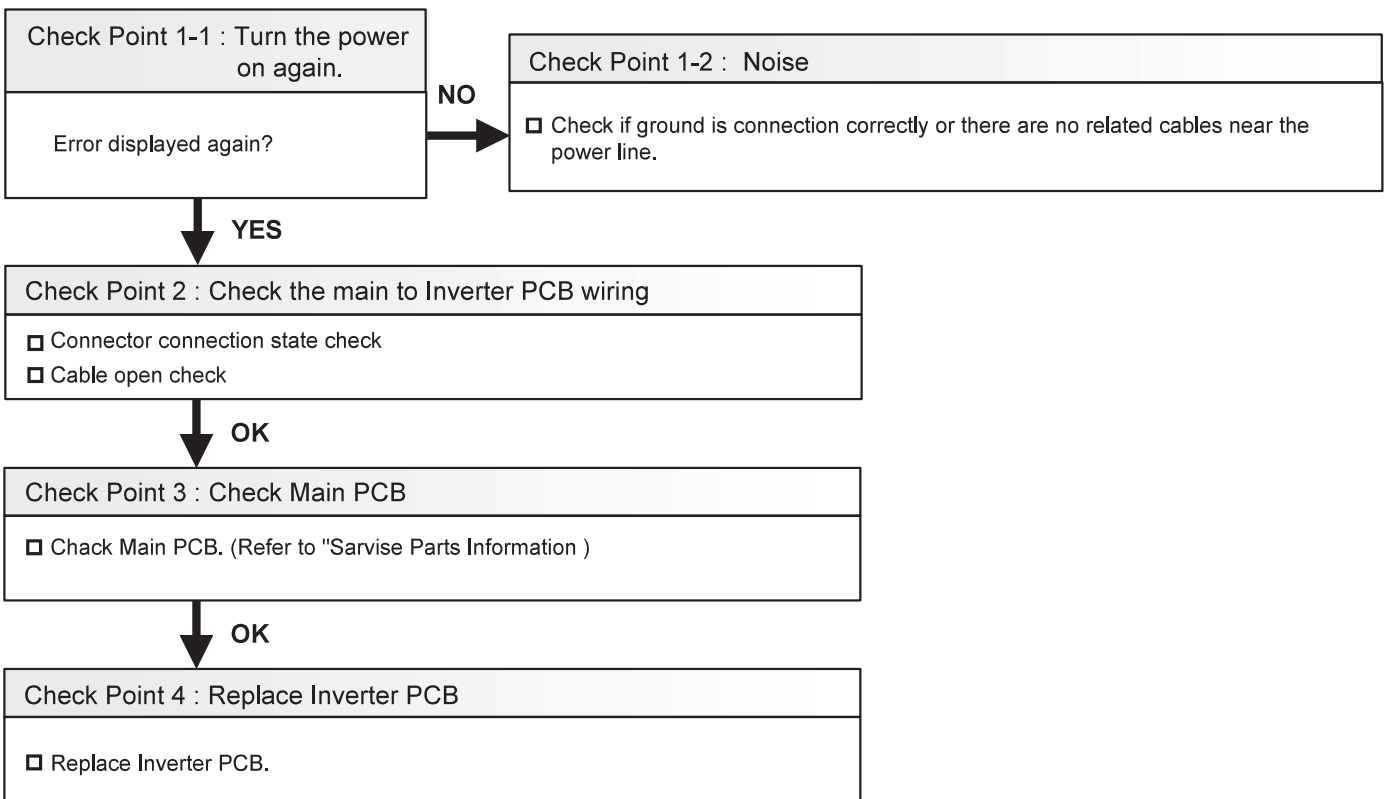

Trouble shooting 17 OUTDOOR UNIT Error Method: EEPROM Data corrupted Error	Indicate or Display: Outdoor Unit : E. 62. 8 Indoor Unit : Operation LED 9 times Flash, Timer LED 15 Times Flash, Filter LED Continuous Flash. Error Code : 62
---	---

Detective Actuators: Outdoor unit Main PCB	Detective details: <ul style="list-style-type: none"> ▪ Set contents sum value memorized in EEPROM and sum value calculated based on the set contents read from EEPROM do not match * Regarding the sum value, only the contents set in the push button SW setting mode (F2) shall be the objective.
--	--

Forecast of Cause : 1. Noise, momentary open, voltage drop 2. Main PCB defective

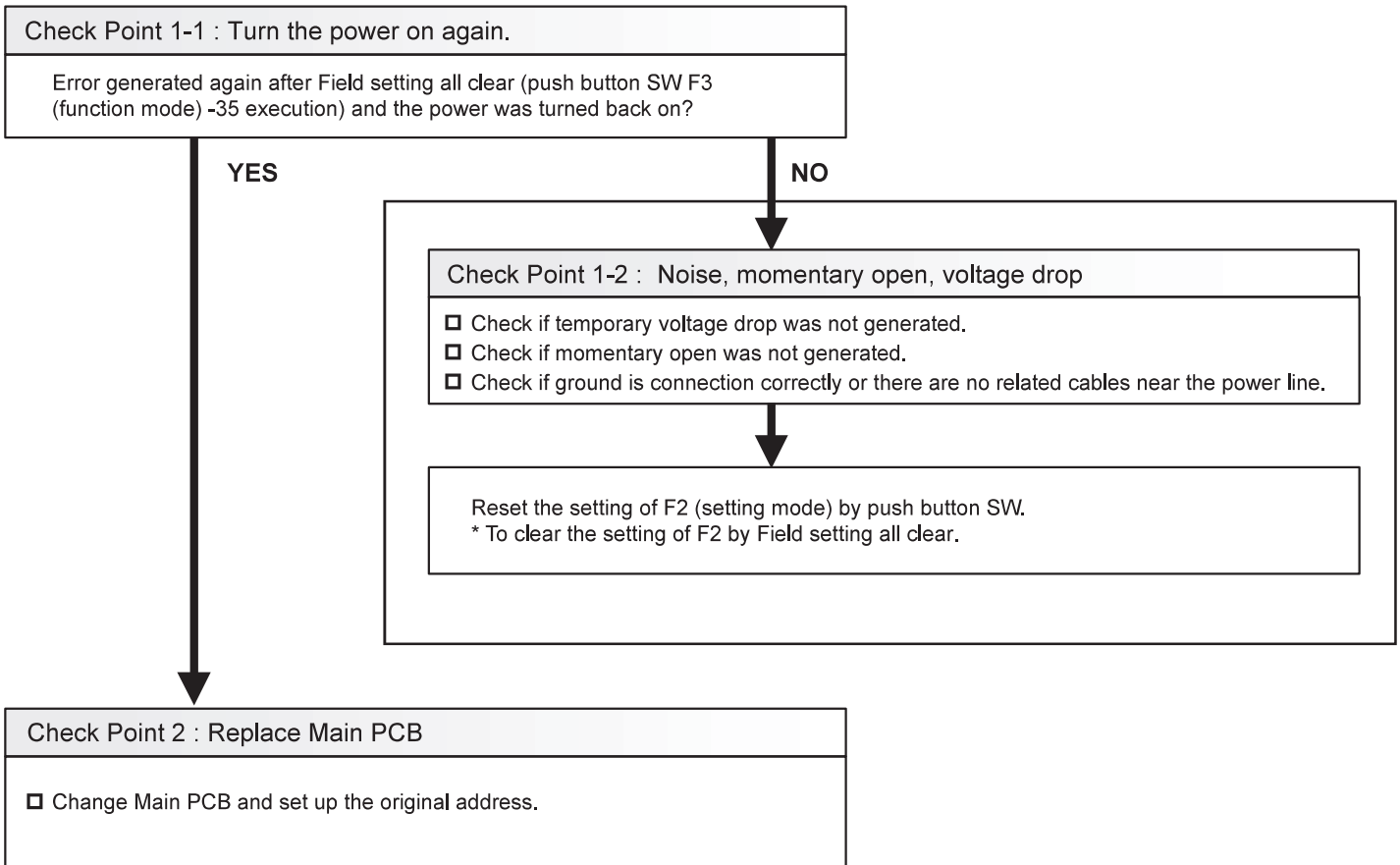

Trouble shooting 18 OUTDOOR UNIT Error Method: Inverter Error	Indicate or Display: Outdoor Unit : E. 63. 1 Indoor Unit : Operation LED 9 times Flash, Timer LED 15 Times Flash, Filter LED Continuous Flash. Error Code : 63
--	---

Detective Actuators: Inverter PCB Filter PCB	Detective details: •Error information received from Inverter PCB
---	--

Forecast of Cause : 1. Noise, momentary open, voltage drop. 2. Power supply to Filter PCB (INV) to Inverter PCB wiring disconnection, open 3. Filter PCB (INV) defective 4. Inverter PCB defective

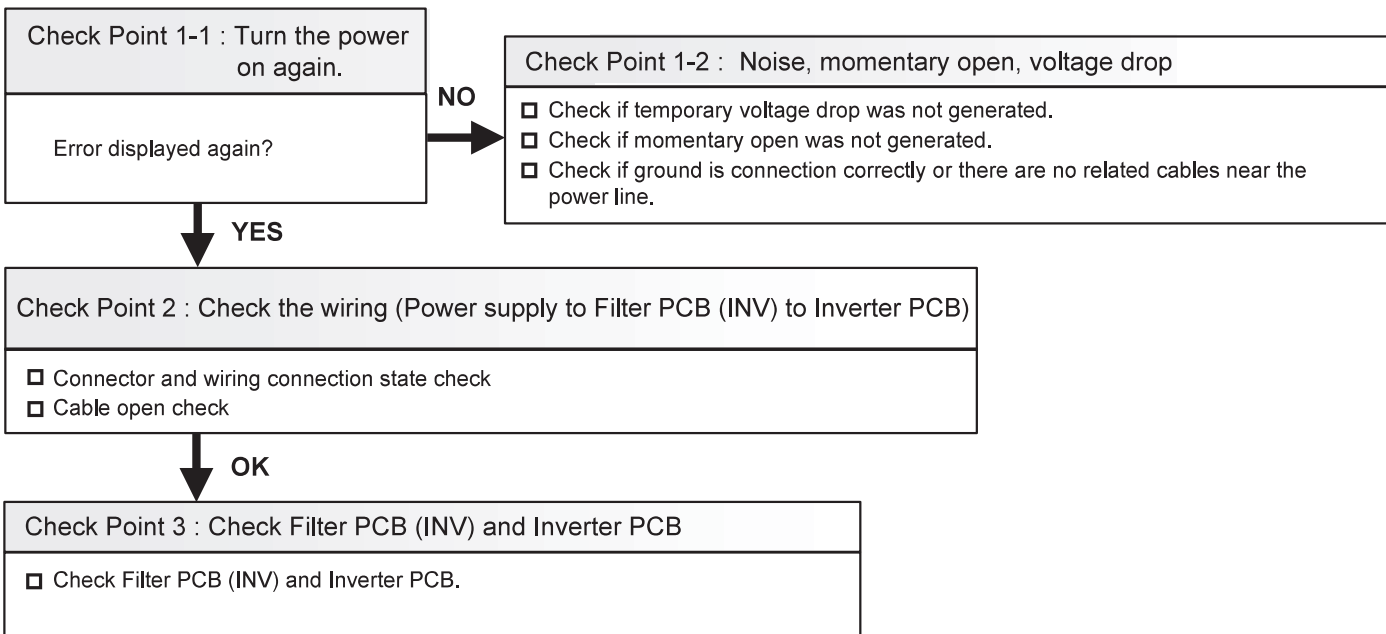

Trouble shooting 19 OUTDOOR UNIT Error Method: Inverter PCB short interruption detection	Indicate or Display: Outdoor Unit : E. 67. 2 Indoor Unit : No Display Error Code : 67
---	--

Detective Actuators: Inverter PCB	Detective details: · "Momentary power failure" received from Inverter PCB
---	---

Forecast of Cause : <ol style="list-style-type: none"> 1. Noise, momentary power failure, voltage drop 2. Power supply to Filter PCB (INV) to Inverter PCB wiring disconnection, open 3. Main PCB defective 4. Inverter PCB defective
--

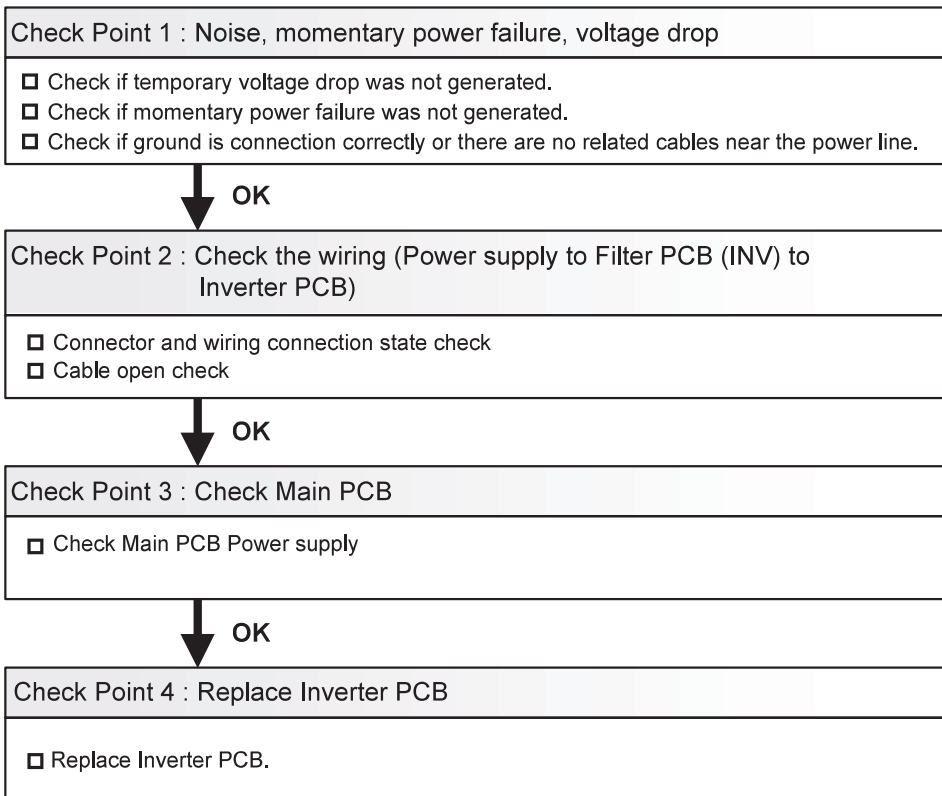

Trouble shooting 20 OUTDOOR UNIT Error Method: Outdoor Unit transmission PCB Parallel Communication Error	Indicate or Display: Outdoor Unit : E. 69. 1 Indoor Unit : Operation LED 9 times Flash, Timer LED 15 Times Flash, Filter LED Continuous Flash. Error Code : 69
--	---

Detective Actuators: Outdoor unit Main PCB Communication PCB	Detective details: •Parallel communication (communication between main CPU and communication PCB) failed 5 times.
---	--

Forecast of Cause :	1. Noise 2. Communication PCB connection defective 3. Communication PCB defective 4. Main PCB defective
----------------------------	--

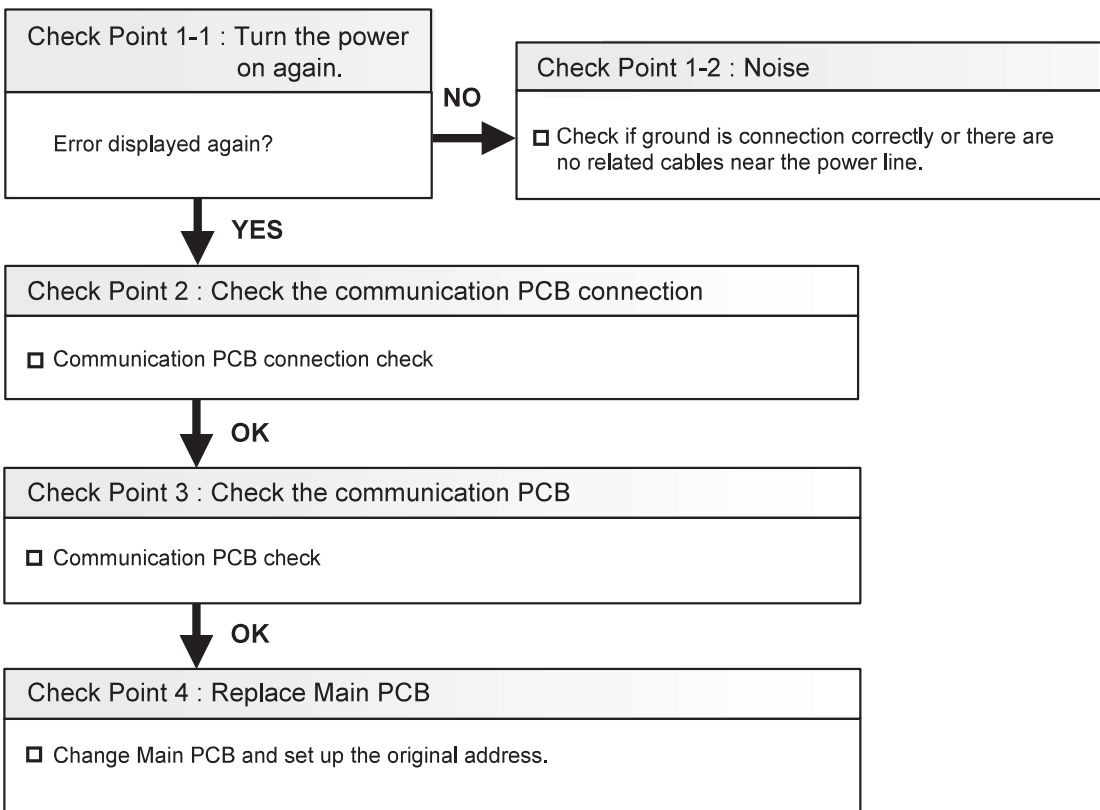

Trouble shooting 21 OUTDOOR UNIT Error Method: Discharge Temp Sensor Error	Indicate or Display: Outdoor Unit : E. 71. 1 Indoor Unit : Operation LED 9 times Flash, Timer LED 15 Times Flash, Filter LED Continuous Flash. Error Code : 71
---	---

Detective Actuators: Discharge temperature thermistor 1	Detective details: <ul style="list-style-type: none"> • Discharge temperature thermistor 1 short detected • Discharge thermistor 1 open detected after compressor 1 operated continuously for 5 minutes or more
---	---

Forecast of Cause : <ol style="list-style-type: none"> 1. Connector connection defective, open 2. Thermistor defective 3. Main PCB defective
--

Check Point 1 : Check the connector connection and cable open <input type="checkbox"/> Connector connection state check <input type="checkbox"/> Cable open check
--

↓
OK

Check Point 2 : Check the thermistor <input type="checkbox"/> Thermistor characteristics check (Disconnect the thermistor from the PCB and check.) * For the thermistor characteristics, refer to the "Service Parts Information 22".
--

↓
OK

Check Point 3 : Check voltage of Main PCB (DC5.0V) <input type="checkbox"/> Main PCB (CN141:1-2) voltage value = 5V <u>Remove the thermistor from Main PCB, check the voltage.</u>	<div style="border: 1px solid black; padding: 5px; width: 40px; margin: 0 auto;">DC</div> 
---	--

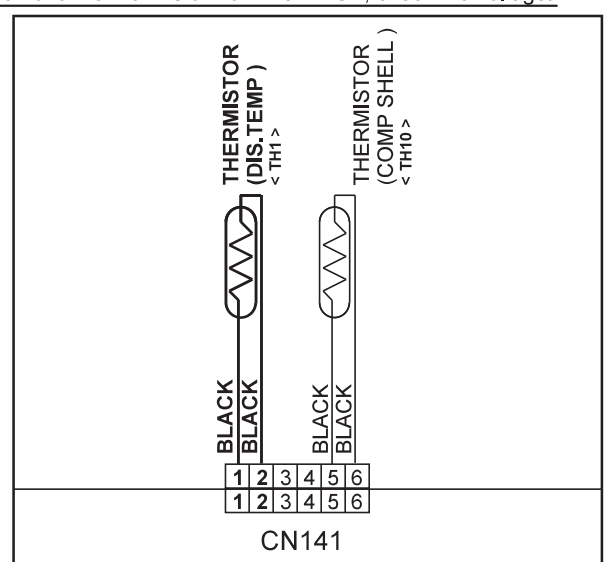

Discharge temperature sensor 1 (CN141:1-2)

▶ **If the voltage does not appear, replace Main PCB and set up original address.**

Trouble shooting 22 OUTDOOR UNIT Error Method: Compressor Temp Sensor Error	Indicate or Display: Outdoor Unit : E. 72. 1 Indoor Unit : Operation LED 9 times Flash, Timer LED 15 Times Flash, Filter LED Continuous Flash. Error Code : 72
--	---

Detective Actuators: Compressor temperature thermistor 1	Detective details: <ul style="list-style-type: none"> • Compressor temperature thermistor 1 short detected • Compressor thermistor 1 open detected after compressor 1 operated continuously for 5 minutes or more
--	--

Forecast of Cause :

1. Connector connection defective, open
2. Thermistor defective
3. Main PCB defective

Check Point 1 : Check the connector connection and cable open

Connector connection state check

Cable open check

↓
OK

Check Point 2 : Check the thermistor

Thermistor characteristics check (Disconnect the thermistor from the PCB and check.)
 * For the thermistor characteristics, refer to the "Service Parts Information 22".

↓
OK

Check Point 3 : Check voltage of Main PCB (DC5.0V)

Main PCB (CN141:5-6) voltage value = 5V
Remove the thermistor from Main PCB, check the voltage.

DC



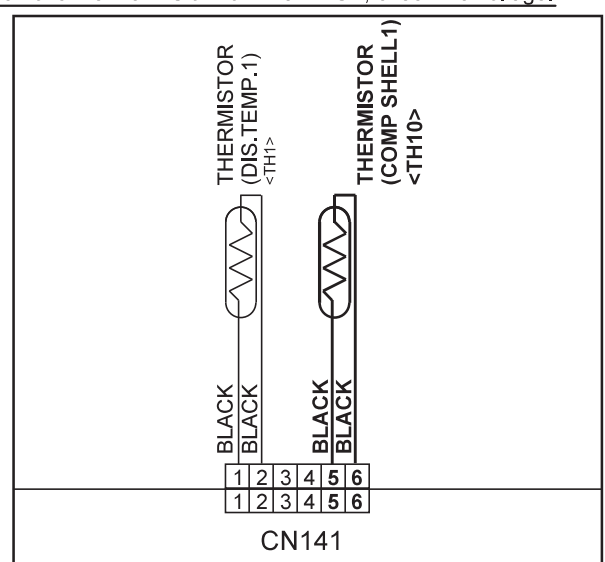

CN141

Compressor temperature sensor 1 (CN141:5-6)

▶ **If the voltage does not appear, replace Main PCB and set up original address.**

Trouble shooting 23 OUTDOOR UNIT Error Method: Outdoor Unit Heat Ex. Liquid Temp. Sensor Error	Indicate or Display: Outdoor Unit : E. 73. 3 Indoor Unit : Operation LED 9 times Flash, Timer LED 15 Times Flash, Filter LED Continuous Flash. Error Code : 73
---	--

Detective Actuators: Heat exchanger liquid temperature thermistor	Detective details: • Heat exchanger liquid temperature thermistor short or open detected
---	--

Forecast of Cause : <ol style="list-style-type: none"> 1. Connector connection defective, open 2. Thermistor defective 3. Main PCB defective
--

Check Point 1 : Check the connector connection and cable open <input type="checkbox"/> Connector connection state check <input type="checkbox"/> Cable open check



Check Point 2 : Check the thermistor <input type="checkbox"/> Thermistor characteristics check (Disconnect the thermistor from the PCB and check.) * For the thermistor characteristics, refer to the "Service Parts Information 22".

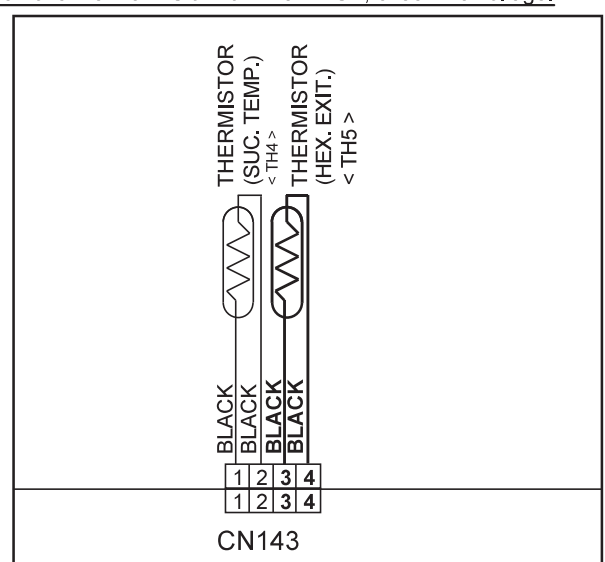

Check Point 3 : Check voltage of Main PCB (DC5.0V) <input type="checkbox"/> Main PCB (CN143:3-4) voltage value = 5V <u>Remove the thermistor from Main PCB, check the voltage.</u>	<div style="border: 1px solid black; padding: 5px; width: 40px; margin: 0 auto;">DC</div> 
	
Heat exchanger liquid temperature sensor (CN143:3-4) ▶ If the voltage does not appear, replace Main PCB and set up original address.	

Trouble shooting 24 OUTDOOR UNIT Error Method: Outdoor Temp Sensor Error	Indicate or Display: Outdoor Unit : E. 74. 1 Indoor Unit : Operation LED 9 times Flash, Timer LED 15 Times Flash, Filter LED Continuous Flash. Error Code : 74
---	---

Detective Actuators: Outdoor temperature thermistor	Detective details: • Outdoor temperature thermistor short or open detected
---	--

Forecast of Cause : <ol style="list-style-type: none"> 1. Connector connection defective, open 2. Thermistor defective 3. Main PCB defective
--

Check Point 1 : Check the connector connection and cable open <input type="checkbox"/> Connector connection state check <input type="checkbox"/> Cable open check

↓ OK

Check Point 2: Check the thermistor <input type="checkbox"/> Thermistor characteristics check (Disconnect the thermistor from the PCB and check.) * For the thermistor characteristics, refer to the "Service Parts Information ".
--

↓ OK

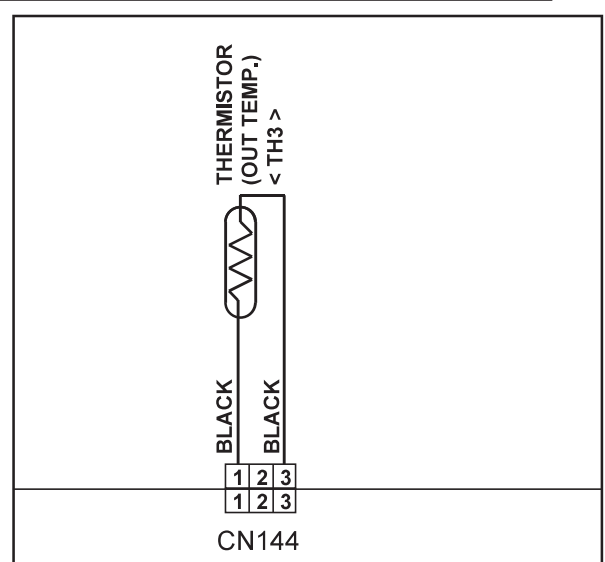
Check Point 3 : Check voltage of Main PCB (DC5.0V) <input type="checkbox"/> Main PCB (CN144:1-3) voltage value = 5V <u>Remove the thermistor from Main PCB, check the voltage.</u>	<div style="border: 1px solid black; padding: 5px; width: 40px; margin: 0 auto;">DC</div> 
	
Outdoor temperature sensor (CN144:1-3) ▶ If the voltage does not appear, replace Main PCB and set up original address.	

Trouble shooting 25 OUTDOOR UNIT Error Method: Suction Gas Temp Sensor Error	Indicate or Display: Outdoor Unit : E. 75. 1 Indoor Unit : Operation LED 9 times Flash, Timer LED 15 Times Flash, Filter LED Continuous Flash. Error Code : 75
---	---

Detective Actuators: Suction gas temperature thermistor	Detective details: • Suction gas temperature thermistor short or open detected
---	--

Forecast of Cause :	1. Connector connection defective, open 2. Thermistor defective 3. Main PCB defective
----------------------------	---

Check Point 1 : Check the connector connection and cable open
<input type="checkbox"/> Connector connection state check <input type="checkbox"/> Cable open check

↓ OK

Check Point 2 : Check the thermistor
<input type="checkbox"/> Thermistor characteristics check (Disconnect the thermistor from the PCB and check.) * For the thermistor characteristics, refer to the "Service Parts Information 22".

↓ OK

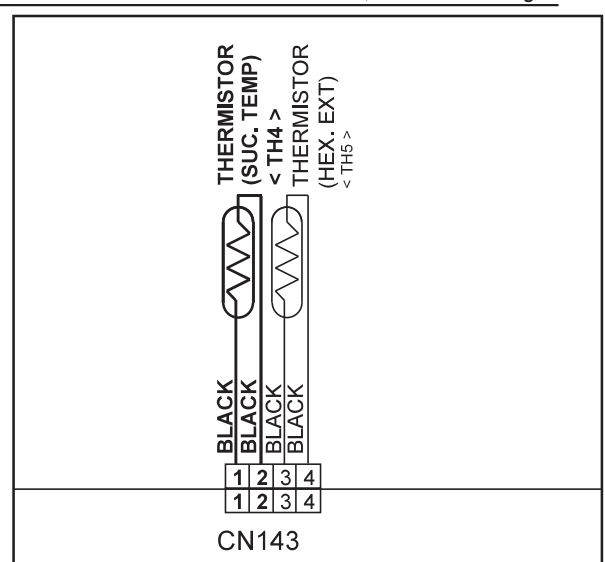
Check Point 3 : Check voltage of Main PCB (DC5.0V)	<div style="border: 1px solid black; padding: 5px; display: inline-block;">DC</div> 
<input type="checkbox"/> Main PCB (CN143:1-2) voltage value = 5V <u>Remove the thermistor from Main PCB, check the voltage.</u>	
	
Suction gas temperature sensor (CN143:1-2)	
▶ If the voltage does not appear, replace Main PCB and set up original address.	

<p>Trouble shooting 26 <u>OUTDOOR UNIT Error Method:</u> Heat Sink Temp Sensor Error</p>	<p><u>Indicate or Display:</u> Outdoor Unit : E. 77. 1 Indoor Unit : Operation LED 9 times Flash, Timer LED 15 Times Flash, Filter LED Continuous Flash. Error Code : 77</p>
--	--

<p><u>Detective Actuators:</u> Inverter PCB</p>	<p><u>Detective details:</u> • Heat sink temperature thermistor (Inside IPM) open/short circuit detected</p>
---	--

<p><u>Forecast of Cause :</u> 1. Inverter PCB failure ▶ <u>If this error is displayed, replace Inverter PCB</u></p>
--

Trouble shooting 27 OUTDOOR UNIT Error Method: Sub-cool Heat EX. Gas Inlet Temp Sensor Error	Indicate or Display: Outdoor Unit : E. 82. 1 Indoor Unit : Operation LED 9 times Flash, Timer LED 15 Times Flash, Filter LED Continuous Flash. Error Code : 82
---	---

Detective Actuators: Sub-cooling heat exchanger gas inlet temperature thermistor	Detective details: • Sub-cooling heat exchanger gas inlet temperature thermistor short or open detected
--	---

Forecast of Cause : <ol style="list-style-type: none"> 1. Connector connection defective, open 2. Thermistor defective 3. Main PCB defective
--

Check Point 1 : Check the connector connection and cable open
<input type="checkbox"/> Connector connection state check <input type="checkbox"/> Cable open check

↓ **OK**

Check Point 2 : Check the thermistor
<input type="checkbox"/> Thermistor characteristics check (Disconnect the thermistor from the PCB and check.) * For the thermistor characteristics, refer to the "Service Parts Information 22".

↓ **OK**

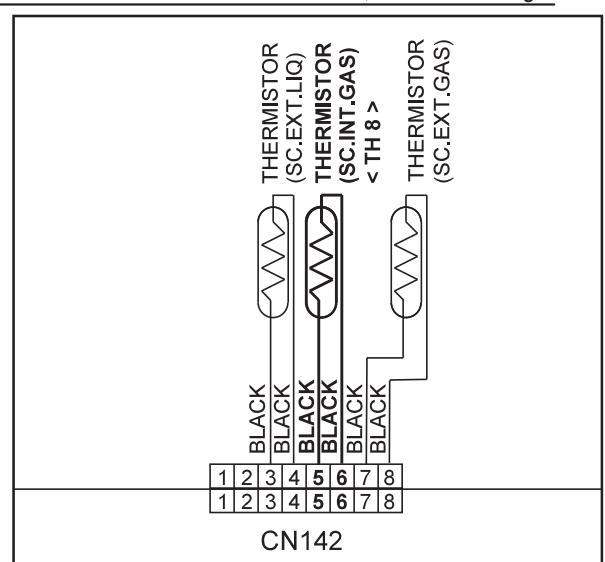
Check Point 3 : Check voltage of Main PCB (DC5.0V)	<div style="border: 1px solid black; padding: 5px; display: inline-block;">DC</div> 
<input type="checkbox"/> Main PCB (CN142:5-6) voltage value = 5V <u>Remove the thermistor from Main PCB, check the voltage.</u>	
	
Sub-cooling heat exchanger gas inlet temperature sensor (CN142:5-6)	

Trouble shooting 28 OUTDOOR UNIT Error Method: Sub-cool Heat EX. Gas outlet Temp Sensor Error	Indicate or Display: Outdoor Unit : E. 82. 2 Indoor Unit : Operation LED 9 times Flash, Timer LED 15 Times Flash, Filter LED Continuous Flash. Error Code : 82
--	---

Detective Actuators: Sub-cooling heat exchanger gas outlet temperature thermistor	Detective details: • Sub-cooling heat exchanger gas outlet temperature thermistor short or open detected
---	--

Forecast of Cause : <ol style="list-style-type: none"> 1. Connector connection defective, open 2. Thermistor defective 3. Main PCB defective
--

Check Point 1 : Check the connector connection and cable open
<input type="checkbox"/> Connector connection state check <input type="checkbox"/> Cable open check

↓
OK

Check Point 2 : Check the thermistor
<input type="checkbox"/> Thermistor characteristics check (Disconnect the thermistor from the PCB and check.) * For the thermistor characteristics, refer to the "Service Parts Information 22".

↓
OK

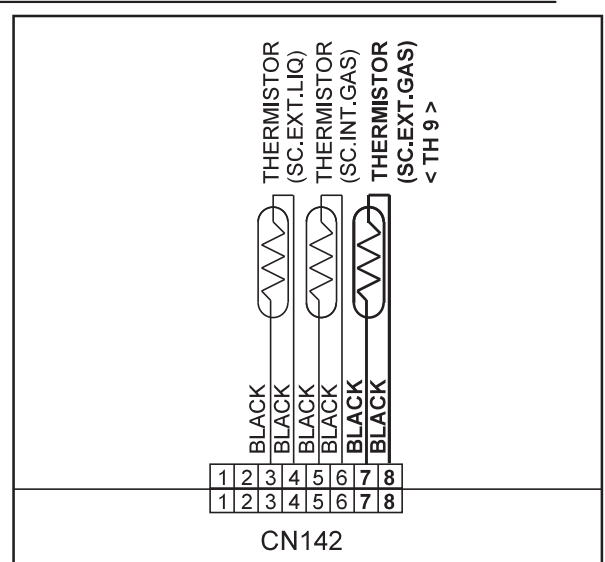
Check Point 3 : Check voltage of Main PCB (DC5.0V)	<div style="border: 1px solid black; padding: 5px; display: inline-block;">DC</div> 
<input type="checkbox"/> Main PCB (CN142:7-8) voltage value = 5V Remove the thermistor from Main PCB, check the voltage.	
	
Sub-cooling heat exchanger gas outlet temperature sensor (CN142:7-8)	

Trouble shooting 29 OUTDOOR UNIT Error Method: SC.HE. Liquid Outlet Sensor Error	Indicate or Display: Outdoor Unit : E. 83. 2 Indoor Unit : Operation LED 9 times Flash, Timer LED 15 Times Flash, Filter LED Continuous Flash. Error Code : 83
---	---

Detective Actuators: Liquid pipe temperature thermistor	Detective details: • SC.HE.Liquid Outlet temperature thermistor 2 short or open detected
---	--

Forecast of Cause : <ol style="list-style-type: none"> 1. Connector connection defective, open 2. Thermistor defective 3. Main PCB defective
--

Check Point 1 : Check the connector connection and cable open <input type="checkbox"/> Connector connection state check <input type="checkbox"/> Cable open check

↓ OK

Check Point 2 : Check the thermistor <input type="checkbox"/> Thermistor characteristics check (Disconnect the thermistor from the PCB and check.) * For the thermistor characteristics, refer to the "Service Parts Information 22".

↓ OK

Check Point 3 : Check voltage of Main PCB (DC5.0V) <input type="checkbox"/> Main PCB (CN142:3-4) voltage value = 5V Remove the thermistor from Main PCB, check the voltage.	<div style="border: 1px solid black; padding: 5px; width: 40px; margin: 0 auto;">DC</div> 
---	--

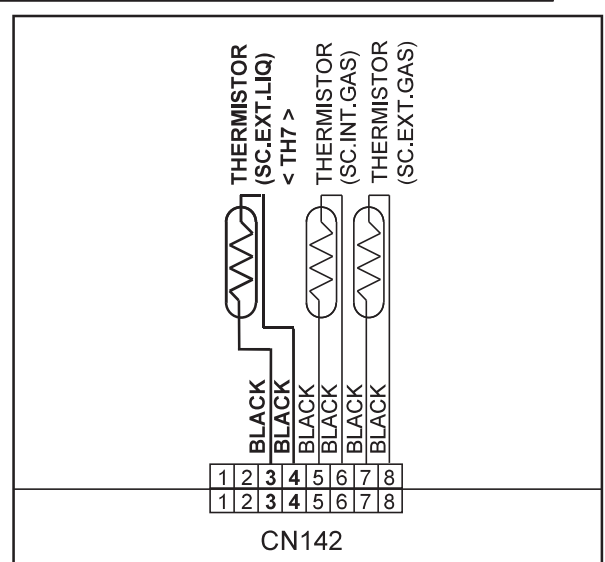

Liquid pipe temperature sensor 2 (CN142:3-4)

Trouble shooting 30 OUTDOOR UNIT Error Method: Current Sensor Error	Indicate or Display: Outdoor Unit : E. 84. 1 Indoor Unit : Operation LED 9 times Flash, Timer LED 15 Times Flash, Filter LED Continuous Flash. Error Code : 84
--	---

Detective Actuators: Judgment from value sensed by current sensor 1 (current sensor for inverter) * Current sensor 1 is mounted on Filter PCB (INV)	Detective details: <ul style="list-style-type: none"> • "Protection stop by "inverter speed ≥ 20rps and sensor value 0A continued for 1 min"" was generated 2 times • Sensor value while inverter stopped = maximum was detected
--	---

Forecast of Cause : <ol style="list-style-type: none"> 1. Filter PCB to Inverter PCB current sensor wiring connector disconnection, open 2. Power supply to Filter PCB to Inverter PC wiring disconnection, open 3. Filter PCB defective (Power supply section, current sensor section) 4. Inverter PCB defective
--

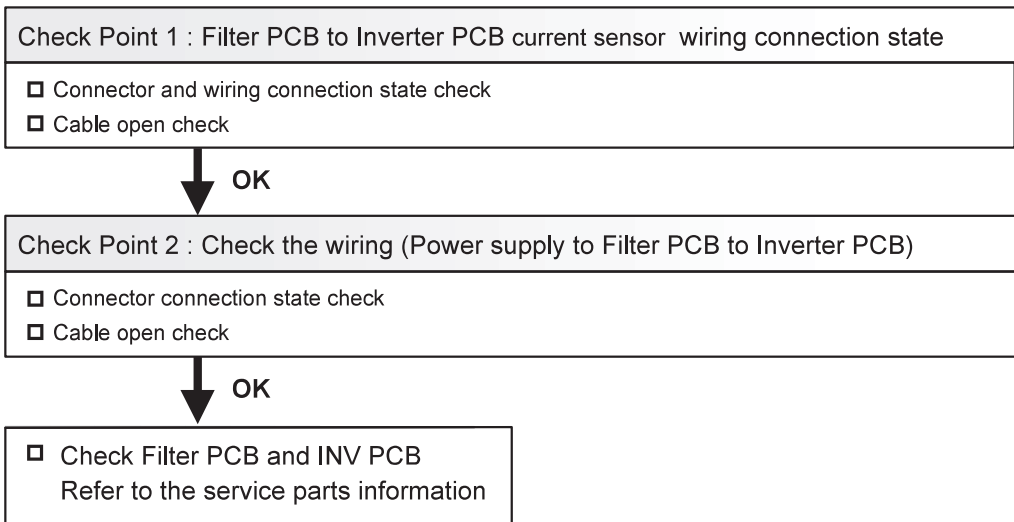

Trouble shooting 31 OUTDOOR UNIT Error Method: Discharge Pressure Sensor Error	Indicate or Display: Outdoor Unit : E. 86. 1 Indoor Unit : Operation LED 9 times Flash, Timer LED 15 Times Flash, Filter LED Continuous Flash. Error Code : 86
---	---

Detective Actuators: Discharge pressure sensor	Detective details: <ul style="list-style-type: none"> • When any of the following conditions is satisfied, a discharge pressure sensor error is generated. <ol style="list-style-type: none"> 1. 30 seconds or more have elapsed since the outdoor unit power was turned on and pressure sensor detected value < 0.3V continued for 30 seconds or more 2. 30 seconds or more have elapsed since the outdoor unit power was turned on and pressure sensor detected value \geq 5.0V was detected.
--	---

Forecast of Cause : <ol style="list-style-type: none"> 1. Discharge pressure sensor connector disconnection, open 2. Discharge pressure sensor defective 3. Main PCB defective
--

Check Point 1 : Check the discharge pressure sensor connection state
<input type="checkbox"/> Connector connection state check <input type="checkbox"/> Cable open check

↓ OK

Check Point 2 : Check the discharge pressure sensor
<input type="checkbox"/> Sensor characteristics check * For the characteristics of the discharge pressure sensor, refer to the "Service Parts Information 20".

↓ OK

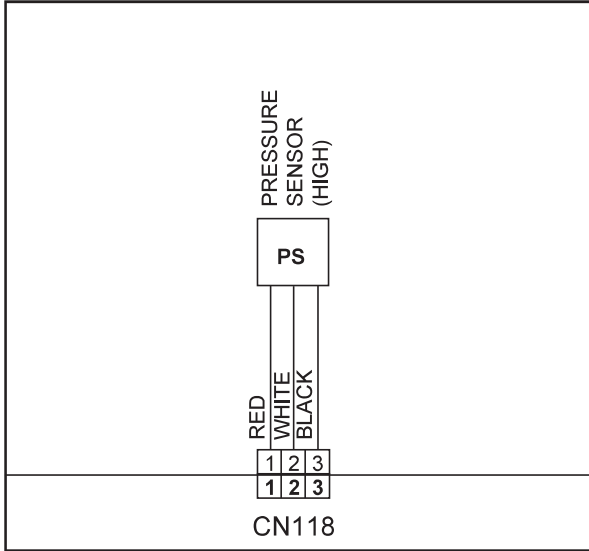
Check Point 3 : Check voltage of Main PCB (DC5.0V)	<div style="border: 1px solid black; padding: 5px; width: 40px; margin: 0 auto;">DC</div> 
<input type="checkbox"/> Main PCB (CN118:1-3) voltage value = 5V <u>Remove the thermistor from Main PCB, check the voltage.</u>	
 <p style="text-align: center;">Discharge pressure sensor (CN118:1-3)</p>	

Trouble shooting 32 OUTDOOR UNIT Error Method: Suction Pressure Sensor Error	Indicate or Display: Outdoor Unit : E. 86. 3 Indoor Unit : Operation LED 9 times Flash, Timer LED 15 Times Flash, Filter LED Continuous Flash. Error Code : 86
---	---

Detective Actuators: Suction pressure sensor	Detective details: <ul style="list-style-type: none"> • When any of the following conditions is satisfied, a suction pressure sensor error is generated. <ol style="list-style-type: none"> 1. 30 seconds or more have elapsed since the outdoor unit power was turned on and pressure sensor detected value < 0.06V continued for 30 seconds or more. 2. 30 seconds or more have elapsed since the outdoor unit power was turned on and pressure sensor detected value \geq 5.0V was detected.
--	---

Forecast of Cause :	1. Suction pressure sensor connector disconnection, open 2. Suction pressure sensor defective 3. Main PCB defective
----------------------------	---

Check Point 1 : Check the suction pressure sensor connection state
<input type="checkbox"/> Connector connection state check <input type="checkbox"/> Cable open check



Check Point 2 : Check the suction pressure sensor
<input type="checkbox"/> Sensor characteristics check * For the characteristics of the suction pressure sensor, refer to the "Service Parts Information".

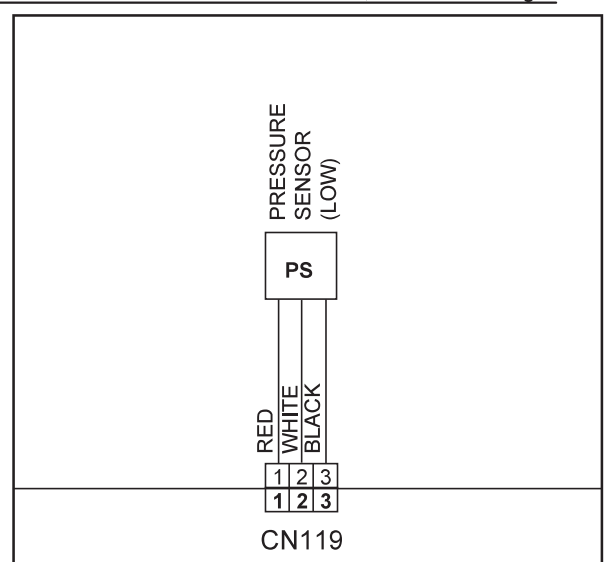

Check Point 3 : Check voltage of Main PCB (DC5.0V)	<div style="border: 1px solid black; padding: 5px; display: inline-block;">DC</div> 
<input type="checkbox"/> Main PCB (CN119:1-3) voltage value = 5V Remove the thermistor from Main PCB, check the voltage.	
	
Suction pressure sensor (CN119:1-3)	

Trouble shooting 33 OUTDOOR UNIT Error Method: High Pressure Switch Error	Indicate or Display: Outdoor Unit : E. 86. 4 Indoor Unit : Operation LED 9 times Flash, Timer LED 15 Times Flash, Filter LED Continuous Flash. Error Code : 86
--	---

<u>Detective Actuators:</u> High pressure switch	<u>Detective details:</u> <ul style="list-style-type: none"> · When the power was turned on, "high pressure switch : open" was detected.
--	---

<u>Forecast of Cause :</u> <ol style="list-style-type: none"> 1. High pressure switch connector disconnection, open 2. High pressure switch characteristics defective 3. Main PCB defective

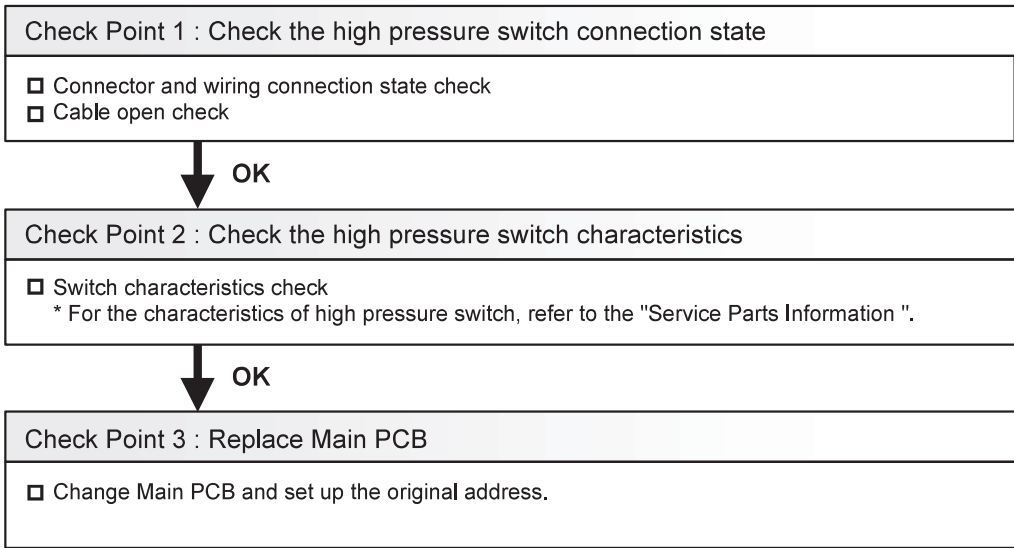

Trouble shooting 34 OUTDOOR UNIT Error Method: Inverter Compressor Start UP Error	Indicate or Display: Outdoor Unit : E. 93. 1 Indoor Unit : Operation LED 9 times Flash, Timer LED 15 Times Flash, Filter LED Continuous Flash. Error Code : 93
--	---

<u>Detective Actuators:</u> Inverter PCB Inverter Compressor	<u>Detective details:</u> <ul style="list-style-type: none"> ▪ "Protection stop by "overcurrent generation at inverter compressor starting" ⇒ restart" generated consecutively 60 times x 2 sets (total 120 times) * The shortest time up to error generation is about 100 minutes * Restart is not performed if an indoor unit in the same refrigerant system is not turned ON by thermostat. * After the end of the 1st set, the 2nd set is not started if all the compressors in the same refrigerant system are not temporarily stopped.
---	--

<u>Forecast of Cause :</u>	1. Inverter PCB to inverter compressor wiring disconnection, open 2. Inverter PCB defective 3. Inverter compressor defective (lock, winding short)
-----------------------------------	--

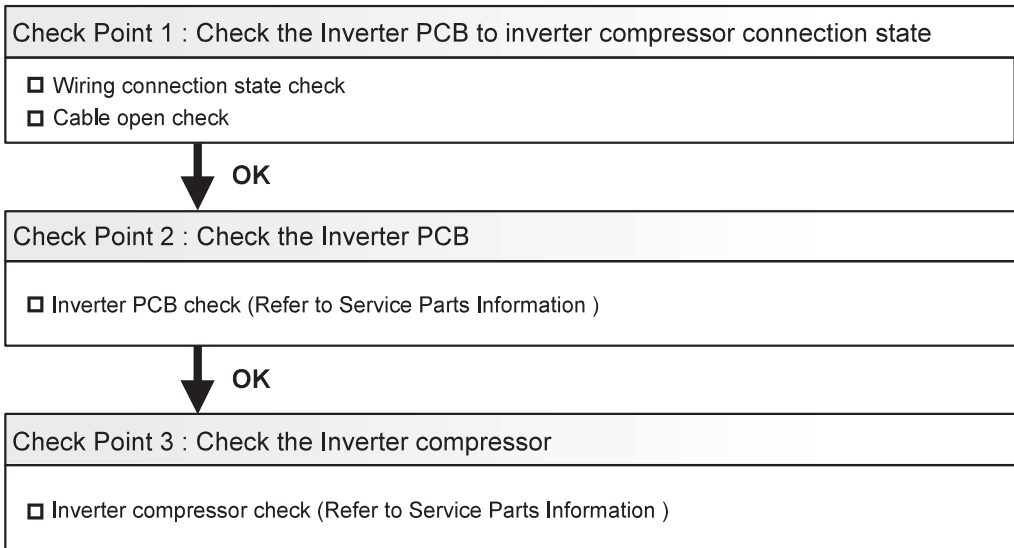

Trouble shooting 35 OUTDOOR UNIT Error Method: Trip Detection	Indicate or Display: Outdoor Unit : E. 94. 1 Indoor Unit : Operation LED 9 times Flash, Timer LED 15 Times Flash, Filter LED Continuous Flash. Error Code : 94
--	---

Detective Actuators: Inverter PCB Inverter Compressor SV 2 coil	Detective details: <ul style="list-style-type: none"> ▪ "Protection stop by "overcurrent generation after inverter compressor start processing completed"" generated consecutively 5 times. * The number of generations is reset if protection stop is not generated again within 40 seconds after restarting.
---	--

Forecast of Cause : <ol style="list-style-type: none"> 1. Outdoor unit fan operation defective, foreign matter on hear exchanger, excessive rise of ambient temperature 2. Inverter PCB defective 3. Inverter compressor defective (lock, winding short) 4. SV2 Coil Abnormal
--

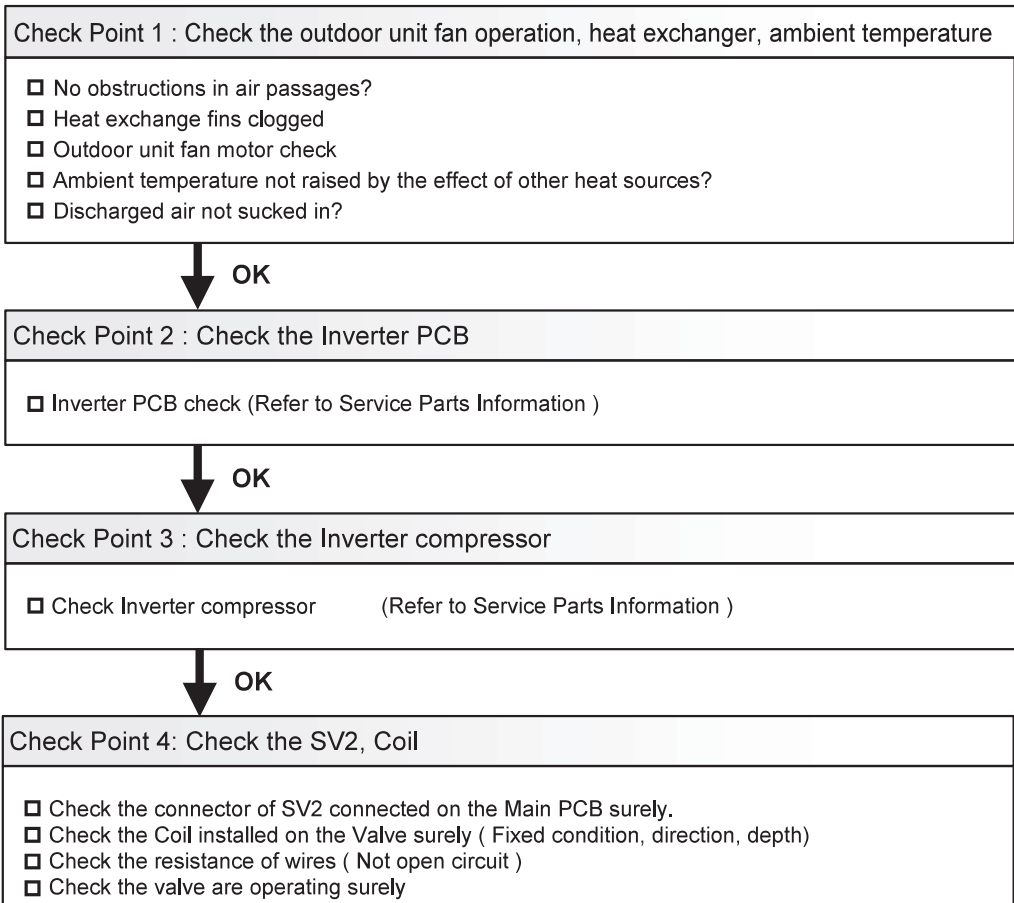

Trouble shooting 36 OUTDOOR UNIT Error Method: Compressor Motor Loss of Synchronization	Indicate or Display: Outdoor Unit : E. 95. 5 Indoor Unit : Operation LED 9 times Flash, Timer LED 15 Times Flash, Filter LED Continuous Flash. Error Code : 95
--	---

<u>Detective Actuators:</u> Inverter PCB Inverter Compressor	<u>Detective details:</u> <ul style="list-style-type: none"> ▪ "Protection stop by "loss of synchronization detection"" generated consecutively 5 times * The number of generations is reset if protection stop is not generated again within 40 seconds after restarting.
---	--

<u>Forecast of Cause :</u> <ol style="list-style-type: none"> 1. Inverter PCB defective 2. Inverter compressor defective (lock)
--

Check Point 1 : Check the Inverter PCB
<input type="checkbox"/> Inverter PCB check (Refer to Service Parts Information)



Check Point 2 : Check the Inverter compressor
<input type="checkbox"/> Inverter compressor check (Refer to Service Parts Information)

Trouble shooting 37 OUTDOOR UNIT Error Method: Outdoor Unit Fan Motor Lock Error - Start up Error -	Indicate or Display: Outdoor Unit : E. 97. 1 (FAN 1) , E. 98. 1 (FAN 2) Indoor Unit : Operation LED 9 times Flash, Timer LED 15 Times Flash, Filter LED Continuous Flash. Error Code : 97 (FAN 1) , 98 (FAN 2)
--	---

Detective Actuators: Outdoor unit fan	Detective details: <ul style="list-style-type: none"> · "Protection stop by "fan speed \leq 100rpm" 20 seconds after fan operation command issued" was generated consecutively 15 times * The compressor is protection stopped every time fan protection stop has been generated 3 times.
---	--

Forecast of Cause :	<ol style="list-style-type: none"> 1. Rotation obstruction by foreign matter 2. Motor wiring, connector disconnection, open 3. Fan motor defective (winding open, lock) 4. Main PCB defective (drive circuit, speed detection circuit)
----------------------------	--

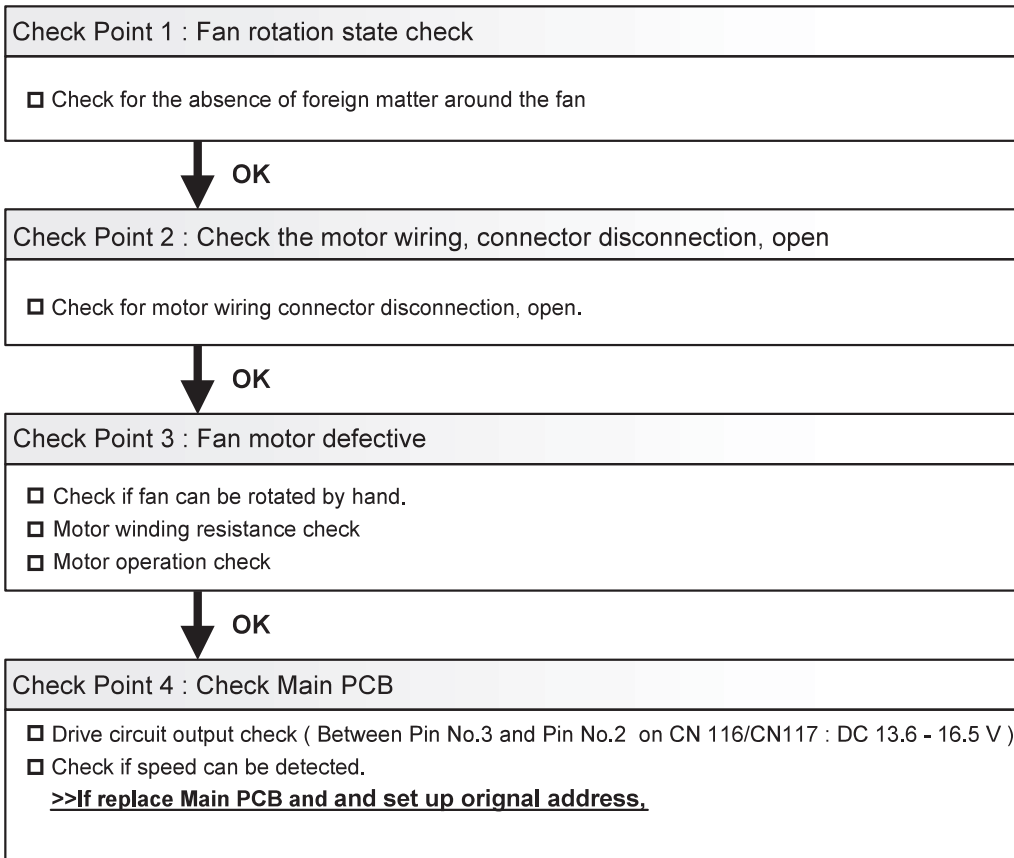

Trouble shooting 38 OUTDOOR UNIT Error Method: Outdoor unit Fan motor undervoltage - Lack of DC Voltage -	Indicate or Display: Outdoor Unit : E. 97. 4 Indoor Unit : Operation LED 9 times Flash, Timer LED 15 Times Flash, Filter LED Continuous Flash. Error Code : 97
--	---

Detective Actuators: Outdoor unit main PCB	Detective details: ▪ Low DC power supply (DC voltage 180V or less) detected
--	---

Forecast of Cause : <ol style="list-style-type: none"> 1. Power OFF, voltage drop, momentary open 2. Power supply wiring connection defective, open 3. Main PCB defective (electrolytic capacitor, DC voltage detection circuit)
--

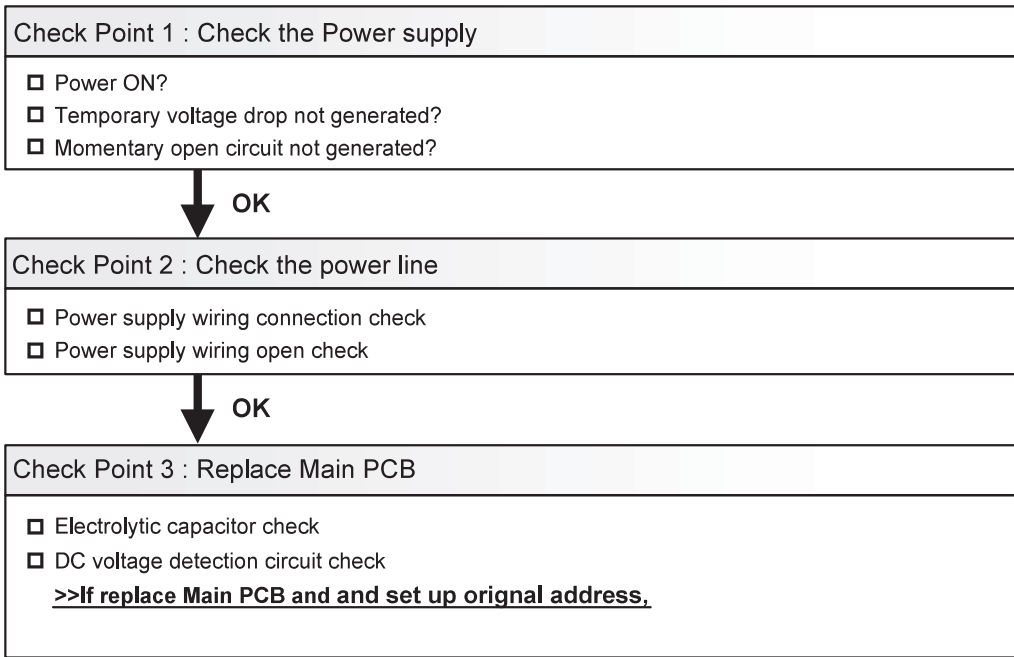

Trouble shooting 39 OUTDOOR UNIT Error Method: Outdoor Unit Fan Motor 1 Temp. Abnormal Outdoor Unit Fan Motor 2 Temp. Abnormal	Indicate or Display: Outdoor Unit : E. 97. 5 (FAN1), E. 98. 5 (FAN2) Indoor Unit : Operation LED 9 times Flash, Timer LED 15 Times Flash, Filter LED Continuous Flash. Error Code : 97 (FAN1), 98 (FAN2)
---	---

Detective Actuators: Outdoor unit fan	Detective details: <ul style="list-style-type: none"> ▪ Protection stop by speed \leq 220rpm after 60 seconds have elapsed after fan operation command issued generated 3 times within 3 hours.
---	---

Forecast of Cause : <ol style="list-style-type: none"> 1. Rotation obstructed by foreign matter 2. Ventilation obstructed by heat exchange foreign matter 3. Excessive ambient temperature rise 4. Static pressure setting incorrect, specified static pressure value exceeded 5. Fan motor defective (internal PCB defective)
--

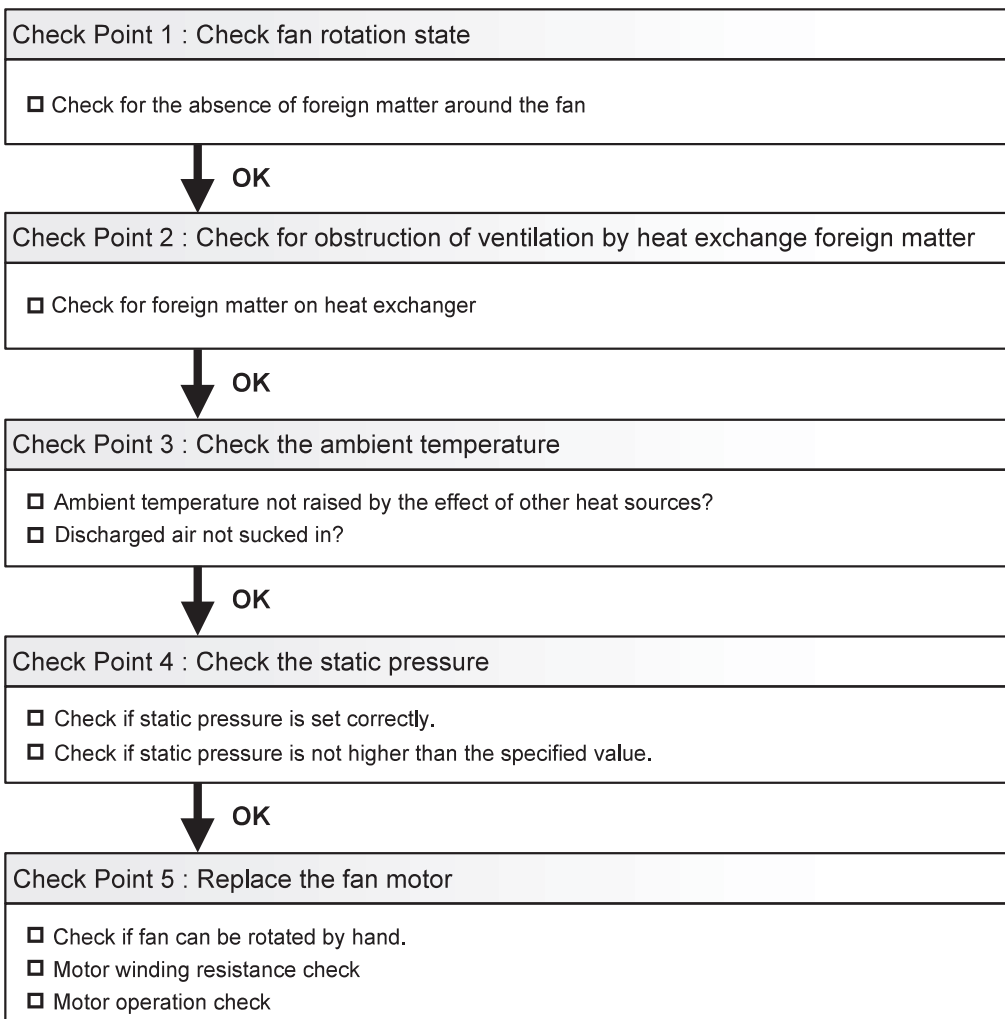

Trouble shooting 40 OUTDOOR UNIT Error Method: Coil EEV1 Error Coil EEV2 Error	Indicate or Display: Outdoor Unit : E. 9A. 1 (EEV1), E. 9A. 2 (EEV2) Indoor Unit : Operation LED 9 times Flash, Timer LED 15 Times Flash, Filter LED Continuous Flash. Error Code : 9A
---	---

Detective Actuators: Main PCB	Detective details: ▪ When the EEV input on the Main PCB (CN116, CN117) was open circuit or short circuit.
---	---

Forecast of Cause :
1. EEV coil lose connection 2. EEV wire(s) cut or pinched 4. Defective EEV coil 3. Main PCB (DC 12V) output abnormal

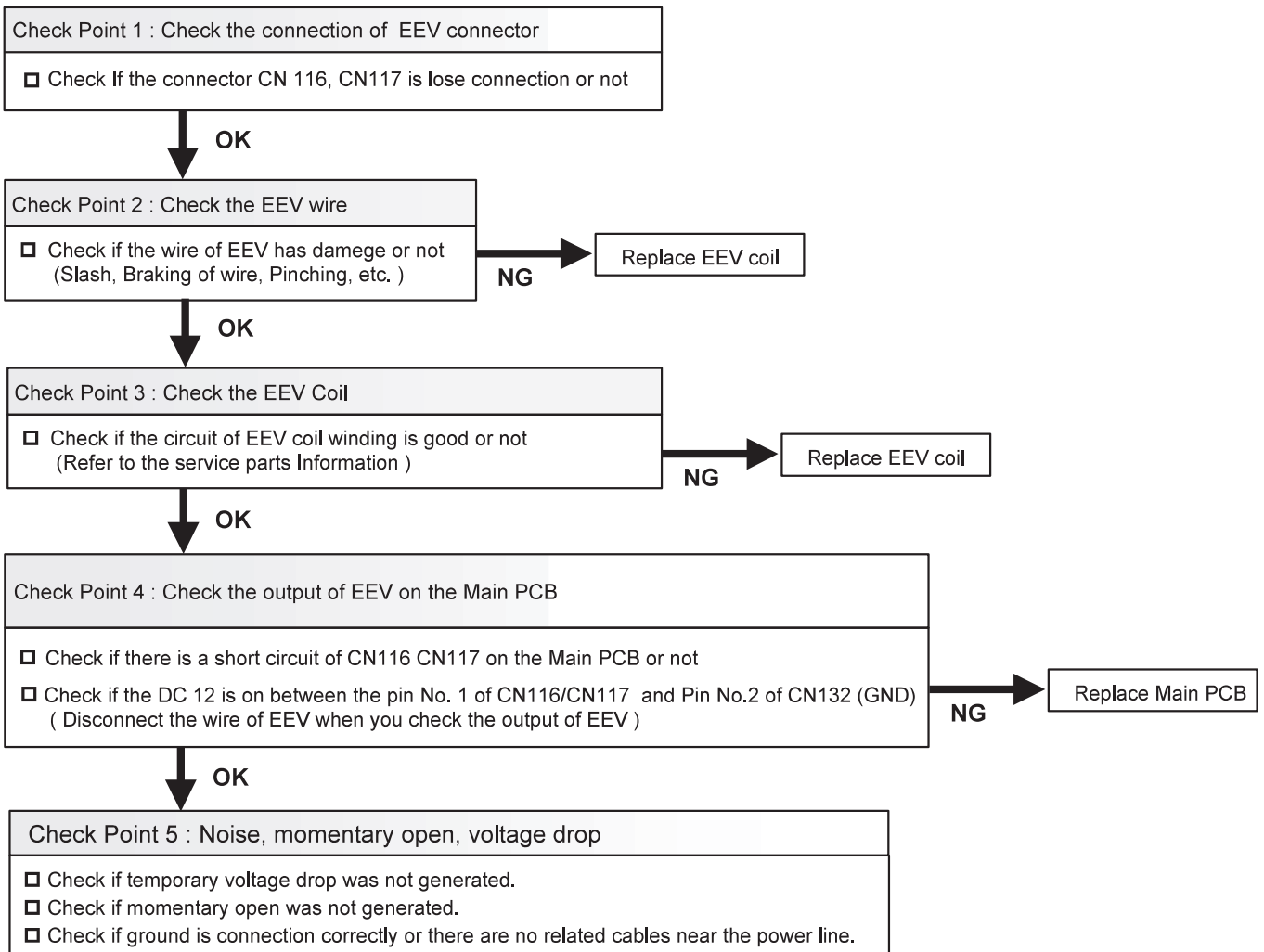

Trouble shooting 41 OUTDOOR UNIT Error Method: Discharge Temperature Abnormal	Indicate or Display: Outdoor Unit : E. A1. 1 Indoor Unit : Operation LED 9 times Flash, Timer LED 15 Times Flash, Filter LED Continuous Flash. Error Code : A1
--	---

Detective Actuators: Discharge temperature thermistor	Detective details: • "Protection stop by "discharge temperature1 \geq 115°C during compressor 1 operation"" generated 2 times within 40 minutes
---	---

Forecast of Cause : <ol style="list-style-type: none"> 1. 3-way valve not opened 2. EEV defective, strainer clogged 3. Outdoor unit operation defective, foreign matter on heat exchanger 4. Discharge temperature thermistor 1 defective 5. Insufficient refrigerant

<Cooling operation>

Check Point 1 : Check if 3-way valve(gas side) is open.
<input type="checkbox"/> If the 3-way valve(gas side) was closed, open the 3-way valve(gas side) and check operation.

↓
OK

Check Point 2 : Check the EEV, strainer
<input type="checkbox"/> EEV (EEV1,EEV2, indoor unit EEV) open? <input type="checkbox"/> Strainer clogging check (before EEV, 3Way Valve, oil return) Refer to "Service Parts Information 14,15,16".

↓
OK

Check Point 3 : Check the outdoor unit fan,heat exchanger
<input type="checkbox"/> Check for foreign matter at heat exchanger <input type="checkbox"/> Check if fan can be rotated by hand. <input type="checkbox"/> Motor check

↓
OK

Check Point 4 : Check the discharge thermistor 1
<input type="checkbox"/> Discharge thermistor 1 characteristics check (Check by disconnecting thermistor from PCB.) * For the characteristics of the thermistor, refer to the "Service Parts Information 22".

↓
OK

Check Point 5 : Check the refrigerant amount
<input type="checkbox"/> Leak check

<Heating operation>

Check Point 1 : Check if 3-way valve(liquid side) is open.
<input type="checkbox"/> If the 3-way valve(liquid side) was closed, open the 3-way valve(liquid side) and check operation.

↓
OK

Check Point 2 : Check the EEV, strainer
<input type="checkbox"/> EEV (EEV1, EEV2) open? <input type="checkbox"/> Strainer clogging check (before EEV, 3Way Valve, oil return) Refer to "Service Parts Information 15, 16".

↙
OK

Trouble shooting 42 OUTDOOR UNIT Error Method: Compressor Temperature Abnormal	Indicate or Display: Outdoor Unit : E. A3. 1 Indoor Unit : Operation LED 9 times Flash, Timer LED 15 Times Flash, Filter LED Continuous Flash. Error Code : A3
---	---

Detective Actuators: Compressor temperature thermistor	Detective details: • "Protection stop by "compressor temperature" $\geq 110^{\circ}\text{C}$ during compressor operation" generated 2 times within 40 minutes
--	---

Forecast of Cause : <ol style="list-style-type: none"> 1. 3-way valve not opened 2. EEV defective, strainer clogged 3. Outdoor unit operation defective, foreign matter on heat exchanger 4. Compressor 1 temperature thermistor defective 5. Insufficient refrigerant
--

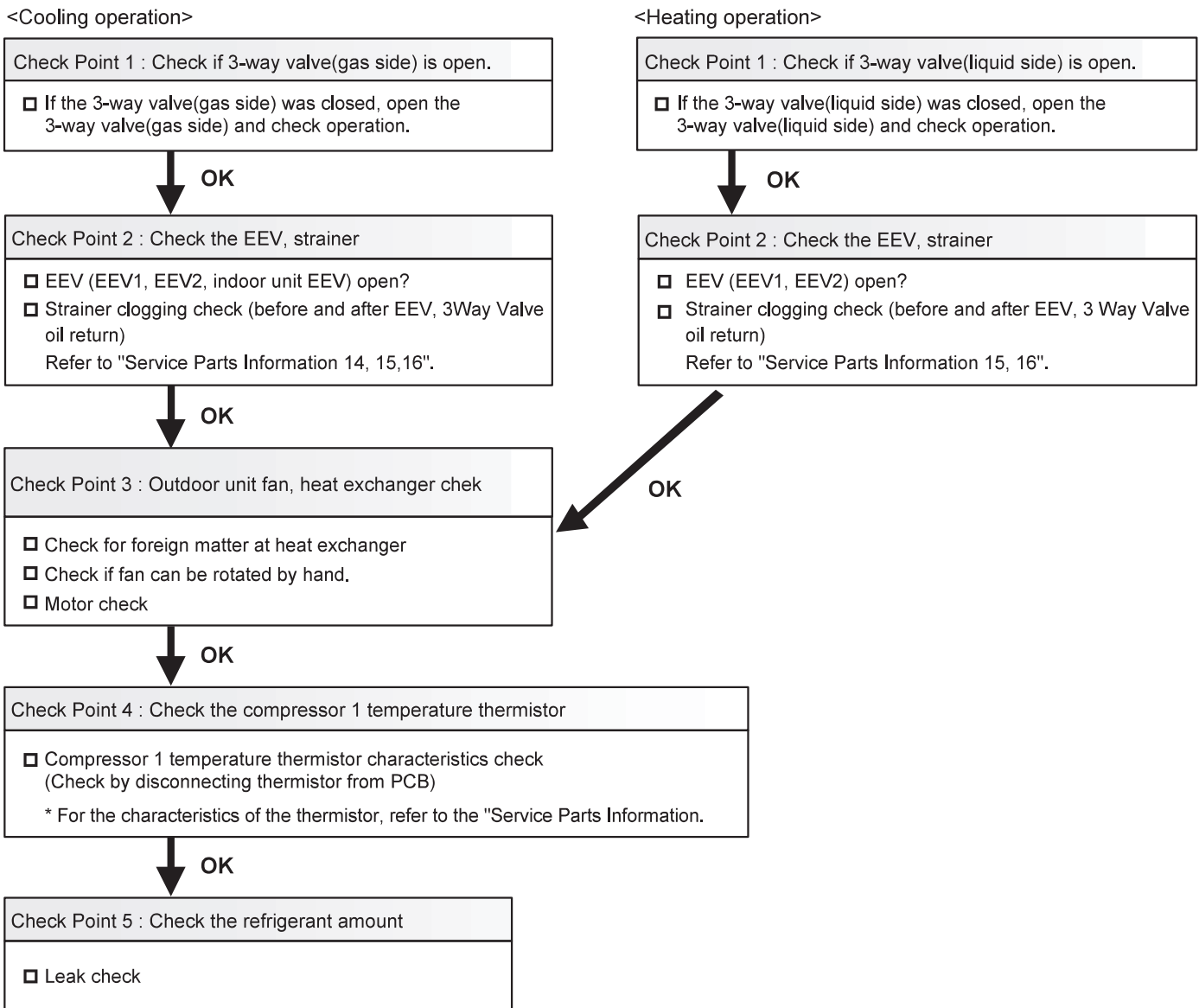

Trouble shooting 43 OUTDOOR UNIT Error Method: High Pressure Abnormal	Indicate or Display: Outdoor Unit : E. A4. 1 Indoor Unit : Operation LED 9 times Flash, Timer LED 15 Times Flash, Filter LED Continuous Flash. Error Code : A4
--	---

Detective Actuators: Judgment from value sensed by discharge pressure sensor	Detective details: ▪ "Protection stop by "discharge pressure \geq 4.00MPa during operation of any compressor"" generated 3 times within 60 minutes
--	--

Forecast of Cause : 1. 3-way valve not opened 2. Outdoor unit fan operation defective, foreign matter at heat exchanger, excessive ambient temperature rise 3. Check valve clogged
4. EEV defective, strainer clogged 5. Solenoid valve defective
6. Discharge pressure sensor defective 7. Refrigerant overcharged

<Cooling operation>

Check Point 1 : Check if 3-way valve(liquid side) is open.
 If the 3-way valve(liquid side) was closed, open the 3-way valve(liquid side) and check operation.



Check Point 2 : Check the outdoor unit fan operation, heat exchanger, ambient temperature
 No foreign matter in air passage?
 Heat exchange fins clogged
 Outdoor unit fan motor check
 Ambient temperature not raised by effect of other heat sources?
 Discharged air not sucked in?



Check Point 3 : Check the EEV, strainer
 EEV(EEV 1) open?
 Strainer clogging check. (before EEV)
Refer to "Service Parts Information".



Check Point 5 : Check the solenoid valve (SV2)
 Solenoid valve operation check
Refer to "Service Parts Information".



Check Point 6 : Check the discharge pressure sensor
 Discharge pressure sensor characteristics check
* For the characteristics of the discharge pressure sensor, refer to "Service Parts Information".



Check Point 7 : Check the refrigerant amount
 Refrigerant charged amount check

<Heating operation>

Check Point 1 : Check if 3-way valve(gas side) is open.
 If the 3-way valve(gas side) was closed, open the 3-way valve(gas side) and check operation.



Check Point 4 : Check the EEV, strainer (indoor unit)
 EEV operation check
 Check of strainers before and after EEV
Refer to "Service Parts Information".

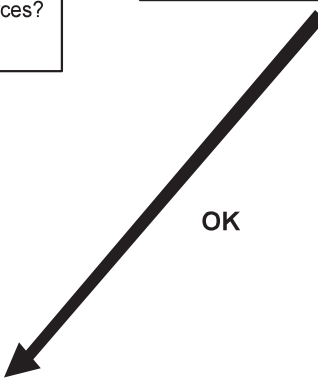

Trouble shooting 44 OUTDOOR UNIT Error Method: High Pressure Protection 1	Indicate or Display: Outdoor Unit : E. A4. 2 Indoor Unit : Operation LED 9 times Flash, Timer LED 15 Times Flash, Filter LED Continuous Flash. Error Code : A4
--	---

Detective Actuators: High pressure switch 1	Detective details: ▪ "Protection stop by "high pressure switch 1 operated during compressor 1 operation"" generated 3 times within 60 minutes
---	---

Forecast of Cause :	1. 3-way valve not opened 2. Outdoor unit fan operation defective, foreign matter at heat exchanger, excessive ambient temperature rise 3. Check valve clogged 4. EEV defective, strainer clogged 5. Solenoid valve defective 6. High pressure switch 1 defective 7. Refrigerant overcharged
----------------------------	--

<Cooling operation>

Check Point 1 : Check if 3-way valve(liquid side) is open.
<input type="checkbox"/> If the 3-way valve(liquid side) was closed, open the 3-way valve(liquid side) and check operation.

↓
OK

Check Point 2 : Check the outdoor unit fan operation, heat exchanger, ambient temperature
<input type="checkbox"/> No foreign matter in air passage? <input type="checkbox"/> Heat exchange fins clogged <input type="checkbox"/> Outdoor unit fan motor check <input type="checkbox"/> Ambient temperature not raised by effect of other heat sources? <input type="checkbox"/> Discharged air not sucked in?

↓
OK

Check Point 3-1 : Check the EEV, strainer
<input type="checkbox"/> EEV(EEV 1) open? <input type="checkbox"/> Strainer clogging check. (before EEV) Refer to "Service Parts Information".

↓
OK

Check Point 3-2 : Check the check valve
<input type="checkbox"/> Check if check valve (oilseparator (out) of compressor 1) is not clogged.

↓
OK

Check Point 5 : Check the solenoid valve (SV2)
<input type="checkbox"/> Solenoid valve operation check Refer to "Service Parts Information".

↓
OK

Check Point 6 : Check high pressure switch 1
<input type="checkbox"/> High pressure switch 1 characteristics check * For the characteristics of the high pressure switch 1, refer to "Service Parts Information".

↓
OK

Check Point 7 : Check the refrigerant amount
<input type="checkbox"/> Refrigerant charged amount check

<Heating operation>

Check Point 1 : Check if 3-way valve(gas side) is open.
<input type="checkbox"/> If the 3-way valve(gas side) was closed, open the 3-way valve(gas side) and check operation.

↓
OK

Check Point 4 : Check the EEV, strainer (indoor unit)
<input type="checkbox"/> EEV operation check <input type="checkbox"/> Check of strainers before and after EEV Refer to "Service Parts Information".

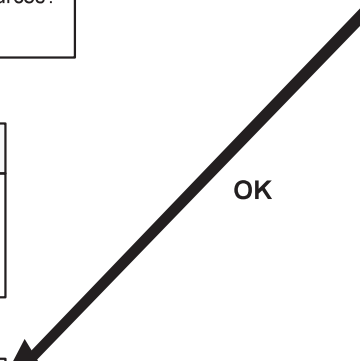

Trouble shooting 45 OUTDOOR UNIT Error Method: Low Pressure Abnormal	Indicate or Display: Outdoor Unit : E. A5. 1 Indoor Unit : Operation LED 9 times Flash, Timer LED 15 Times Flash, Filter LED Continuous Flash. Error Code : A5
---	---

Detective Actuators: Suction pressure sensor	Detective details: <ul style="list-style-type: none"> "Protection stop by "suction pressure \leq 0.10MPa continued for 10 minutes" or "suction pressure \leq 0.05MPa" during operation of any compressor"" was generated 5 times within 3 hours
--	--

Forecast of Cause :	1. 3-way valve not opened 2. Outdoor unit ambient temperature too low 3. Outdoor unit fan operation defective, foreign matter at heat exchanger 4. EEV defective, strainer clogged 5. Solenoid valve defective 6. Low pressure sensor characteristics defective 7. Insufficient refrigerant
----------------------------	--

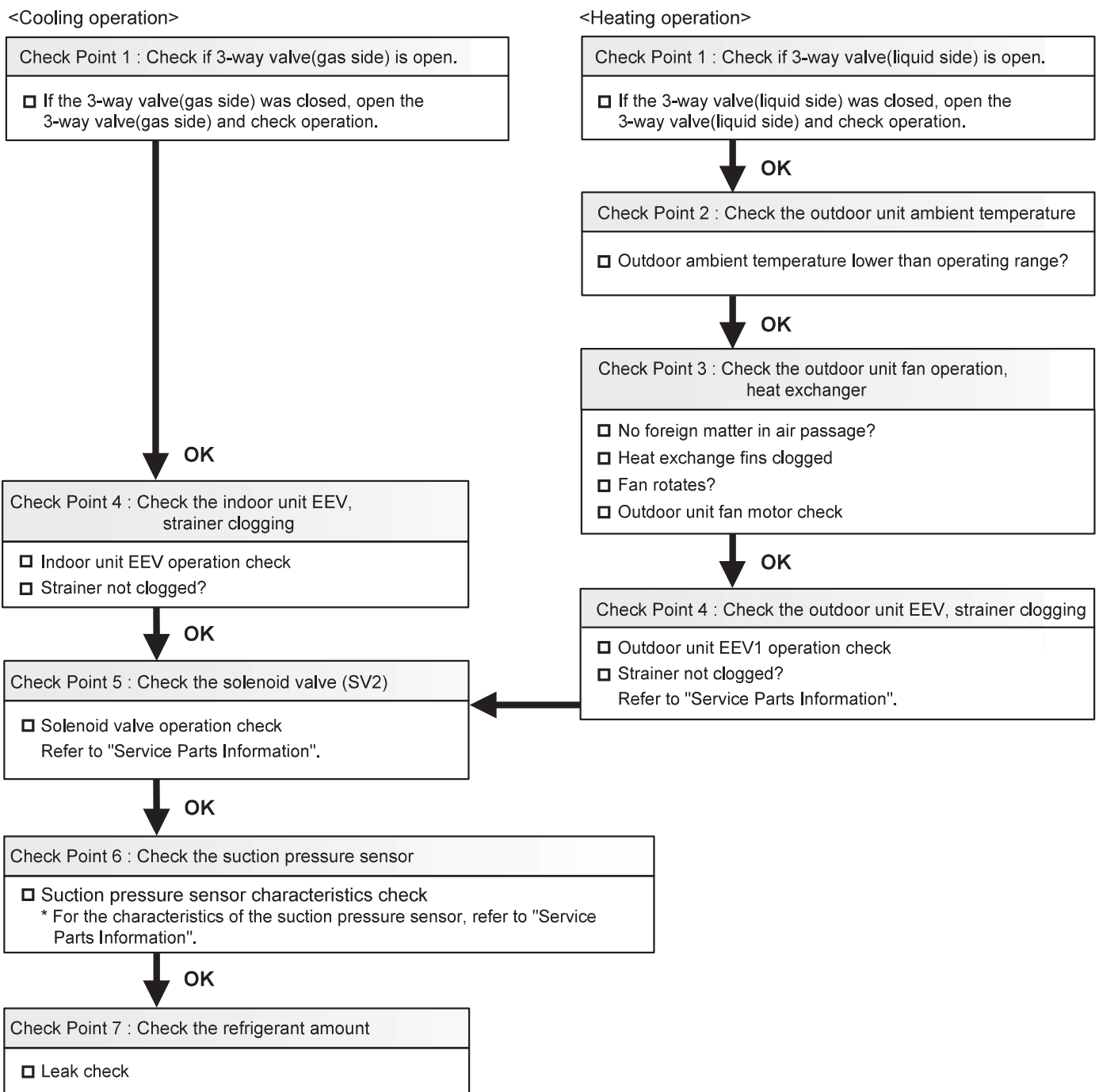

Trouble shooting 45-1 OUTDOOR UNIT Error Method: Outdoor unit Heat Sink Temperature Abnormal	Indicate or Display: Outdoor Unit : E. AC. 4 Indoor Unit : Operation LED 9 times Flash, Timer LED 15 Times Flash, Filter LED Continuous Flash. Error Code : AC
---	---

Detective Actuators: Inverter PCB	Detective details: ▪ "Protection stop by "heat sink temp. $\geq 100^{\circ}\text{C}$ generated 3 times within 60 minutes.
---	--

Forecast of Cause : <ol style="list-style-type: none"> 1. Foreign matter on heat sink, heat sink dirty 2. Foreign matter on heat exchanger, excessive ambient temperature rise 3. Heat sink temp. sensor (Inside IPM) defective

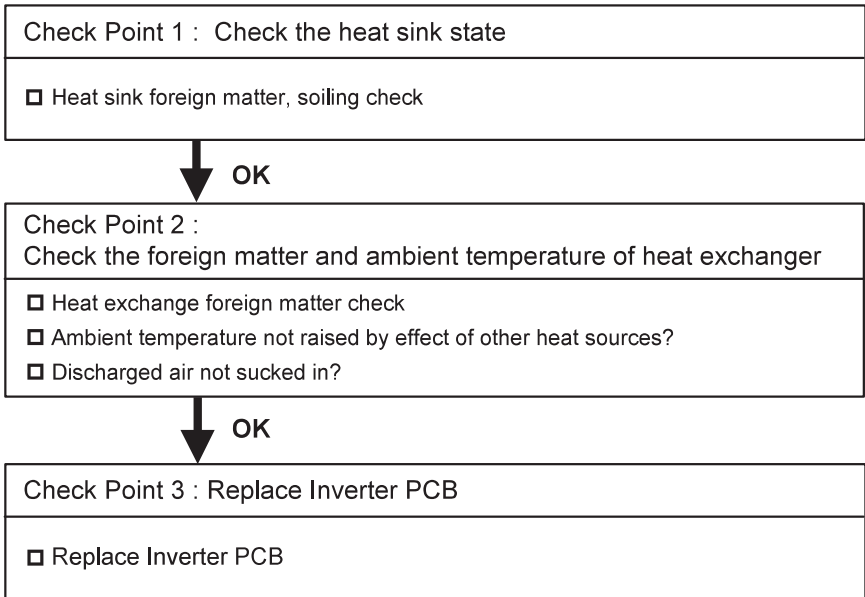

Trouble shooting 46 OUTDOOR UNIT Error Method: Auto Address Setting Error	Indicate or Display: Outdoor Unit : E. 28. 1 Indoor Unit : No Display Error Code : 28
--	--

Detective Actuators: Outdoor unit Main PCB	Detective details: • When none of the connected indoor units answers during auto address And when abnormal answer signal is input.
--	---

Forecast of Cause : 1. Indoor unit power supply defective 2 Indoor unit overconnected
3.Communication line incorrect connection 4. Noise, momentary open

Check Point 1 : Check the indoor unit power supply
 Check the indoor unit power supply



Check Point 2 : Check the indoor unit number connection
 Check if more than 64 indoor units are connected in a refrigerant circuit



Check Point 3 : Check the communication line connection
Check if communication line is correctly connected
 Is it uncoupled or cut halfway ?
 Connecting terminal position is correct as the installation manual shows ?



Check Point 4 : Check noise, momentary open, voltage drop
 Check if power supply temporarily stops by outages or if strong noise is generated from surrounding environment during auto address

Trouble shooting 47 OUTDOOR UNIT Error Method: Signal Amplifier Auto Address Error	Indicate or Display: Outdoor Unit : E. 28. 4 Indoor Unit : No Display Error Code : 28
---	--

Detective Actuators: Outdoor unit Main PCB	Detective details: • When abnormal answer signal is input during signal amplifier auto address
--	--

Forecast of Cause : 1. Signal amplifier power supply defective 2. Signal amplifier overconnected
3. Signal amplifier auto address wrong setting 4. Noise, momentary open.

Check Point 1 : Check signal amplifier unit power supply
 Check signal amplifier unit power supply



Check Point 2 : Check the signal amplifier number connection
 Check if more than 8 signal amplifiers are connected in a network



Check Point 3 : Check the operation of signal amplifier auto address setting
 Check if signal amplifier auto address is set at the same time from multiple outdoor units (master unit)



Check Point 4 : Check noise, momentary open, voltage drop
 Check if power supply temporarily stops by outages or if strong noise is generated from surrounding environment during signal amplifier auto address

Trouble shooting 48 OUTDOOR UNIT Error Method: The number of Indoor unit shortage	Indicate or Display: Outdoor Unit : E.1 4.5 Indoor Unit : No display Error Code : No display
--	---

Detective Actuators: Indoor unit Controller PCB circuit Indoor unit Communication PCB	Detective details: When the indoor unit number decreases for 180 seconds from the memorized maximum indoor units number after power(Breaker) ON.
--	--

Forecast of Cause : 1. Indoor unit power off 2. Noise, momentary open, voltage drop
 3. Communication line connection defective 4. Terminal resistor setting mistake
 5. Communication PCB mounting defective, Communication PCB defective 6. Controller PCB defective

Check Point 1 : Find the indoor unit that the communication is lost.

Check system drawing and service tool.



Check Point 2 : Check the indoor unit power supply

Main power ON check
 Power cable connection and open check



Check Point 2 : Noise, momentary open, voltage drop

Check if temporary voltage drop was not generated.
 Check if momentary open was not generated.
 Check if ground is connection correctly or there are no related cables near the power line.



Check Point 3 : Check the communication line connection

Communication line connection, open check



Check Point 4 : Check the Terminal resistor setting

Terminal resistor setting check



Check Point 5 : Check the communication PCB (indoor unit / outdoor unit)

Communication PCB connection check
 Communication PCB check



Check Point 6 : Replace Main PCB and Communication PCB (indoor unit / outdoor unit)

Change Main PCB and Communication PCB, and set up the original address.

Attention!!
 Even if this error occurs, system does not stop.
 If the failure indoor unit is pinpointed and it needs to erase the error indication, it can be reset by function setting (F3-41: Maximum memorized indoor unit number reset).

TROUBLE SHOOTING WITH NO ERROR CODE

Trouble shooting 49 Indoor Unit - No Power

Forecast of Cause :

1. Power Supply failure 2. Outside cause 3. Electrical Component defective

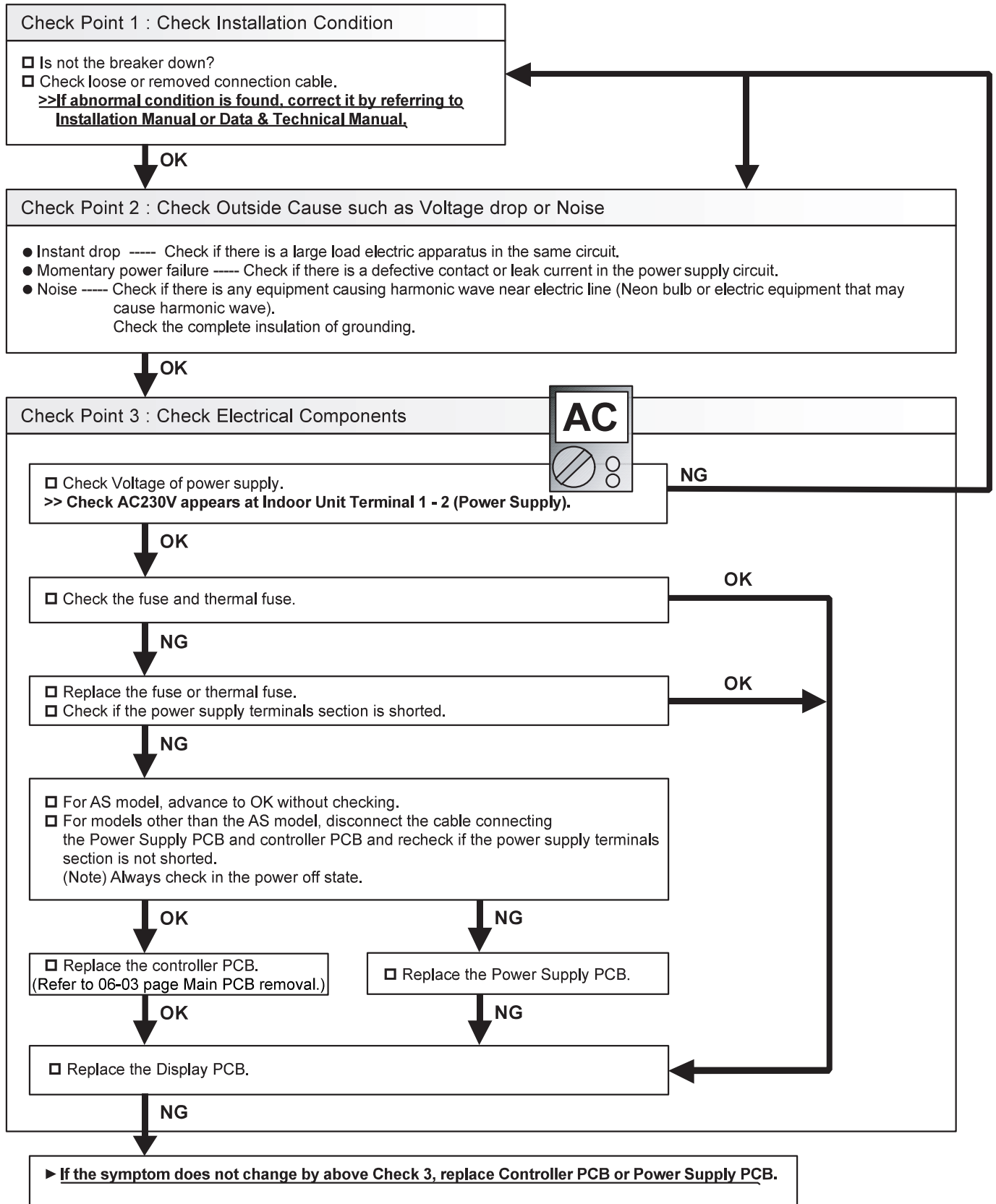

Trouble shooting 50

Outdoor Unit - No Power

Forecast of Cause :

1. Power Supply failure 2. Outside cause 3. Electrical Components defective

Check Point 1 : Check Installation Condition

- Isn't the breaker down?
- Check loose or removed connection cable.
>> **If abnormal condition is found, correct it by referring to Installation Manual or Data & Technical Manual.**

OK

Check Point 2 : Check Outside Cause such as Voltage drop or Noise

- Instant drop ---- Check if there is a large load electric apparatus in the same circuit.
- Momentary power failure ---- Check if there is a defective contact or leak current in the power supply circuit.
- Noise ---- Check if there is any equipment causing harmonic wave near electric line (Neon bulb or electric equipment that may cause harmonic wave).
Check the complete insulation of grounding.

OK

Check Point 3 : Check Electrical Components



- Check the voltage of power supply.
>> **Check if the reted voltage appears at Outdoor Unit Terminal L - N.**

NO

OK

- Check the fuse on the Filter PCB.

NG

- Replace the fuse.
- Recheck if the power supply terminals section is shorted.
(Note) Always check in the power off state.

NG

- Disconnect connecting cable of the Filter PCB and Main PCB and recheck.
if the power supply terminals section is not shorted.
(Note) Always check in the power off state.

OK

NG

- Check If the FAN motor PCB has a damage or not. (Check short circuit)

OK

NG

- Replace the FAN Motor

- Check if the circuit between pin No. 1 and pin No.2 of CN102 / CN150 on the Main PCB has short circuit or not (Short circuit : NG)
* Disconnect FAN motor when check the circuit

NG

- Replace the Inverter PCB

NG

NG

- If the symptom does not change by above Check 3, replace Main PCB or Filter PCB

Trouble shooting 51

No Operation (Power is ON)

Forecast of Cause :

1. Setting/Connection failure
2. Outside cause
3. Electrical Component defective

Check Point 1 : Check indoor and outdoor installation condition

- Indoor Unit - Check incorrect wiring between Indoor Unit- Remote Control, or terminals between Indoor Units.
Or, check if there is an open cable connection.
 - Check address setting (Are all the address of Indoor and Outdoor correct?)
 - Are these Indoor Unit, Outdoor Unit, and Remote Control suitable model numbers to connect?
- >> If there is some abnormal condition, correct it by referring to Installation manual and Data & Technical Manual.**

OK

Turn off Power and check/correct followings.

- Isn't Communication PCB of Indoor Unit removed?
- Is there loose or removed communication line of Indoor Unit and Outdoor Unit?
- Check Terminator (DIP-SW SET 5) is installed on Outdoor Main PCB.
- Check loose or removed communication line between each Outdoor Unit.
- Check loose Communication PCB of each Outdoor Unit.

OK

Check Point 2 : Check outside cause at Indoor and Outdoor (Voltage drop or Noise)

- Instant drop -----Check if there is a large load electric apparatus in the same circuit.
- Momentary power failure ----- Check if there is a defective contact or leak current in the power supply circuit.
- Noise ----- Check if there is any equipment causing harmonic wave near electric line (Neon bulb or electric equipment that may cause harmonic wave).
Check the complete insulation of grounding.

OK

Check Point 3 : Check Electrical Components at Indoor and Outdoor



- Indoor Unit - Check the voltage between pins 1-3 of the connector (on the control PCB) for connection with the remote controller.
>> If it is DC12V, Remote Control is defective (Controller PCB is normal) >> Replace Remote Control
>> If it is DC 0V, Controller PCB is defective (Check Remote Control once again) >> Replace Controller PCB
- If some of Indoor unit does not operate, replace the Communication PCB of the non-operative Indoor Unit.
>> If the symptom does not change, replace Controller PCB of Indoor Unit.
- If all of Indoor Units do not operate, check the connection between Main PCB and Communication PCB of Outdoor Unit (Main Unit).
>> If the symptom does not change, replace Communication PCB of Outdoor Unit (Main Unit).
(If it did not work, replace Main PCB.)

Trouble shooting 52

No Cooling

Forecast of Cause :

1. Indoor Unit error
2. Outdoor Unit error
3. Effect by Surrounding environment
4. Connection Pipe / Connection Wire failure
5. Refrigeration cycle failure

Check Point 1 : Check Indoor Unit

- Does Indoor Unit FAN run on HIGH FAN?
- Is Air Filter dirty?
- Is Heat Exchanger clogged?

OK

Check Point 2 : Check Outdoor Unit Operation

- Check if Outdoor Unit is operating
- Check any objects that obstruct the air flow route.
- Check clogged Heat Exchanger.
- Is the pipe length setting (Push Switch "MODE/EXIT", "SELECT", "ENTER") suitable?
- Is the Valve open?

OK

Check Point 3 : Check Site Condition

- Is capacity of Indoor Unit fitted to Room size?
- Any windows open? Or direct sunlight ?

OK

Check Point 4 : Check Indoor/Outdoor Installation Condition

- Check connection pipe (specified pipe length & Pipe diameter?)
 - Check any loose or removed communication line.
- >> If there is an abnormal condition, correct it by referring to Installation Manual or Data & Technical Manual.**

OK

Check Point 5 : Check Refrigeration Cycle

- Check if Strainer is clogged (Refer to the figure at right).
 - Measure Gas Pressure and if there is a leakage, correct it.
>> When recharging the refrigerant, make sure to perform vacuuming, and recharge the specified amount.
- ▶ Check EEV (Refer to Service Parts Information)
 - ▶ Check Solenoid Valve (Refer to Service Parts Information)
 - ▶ Check Compressor (Refer to Service Parts Information)

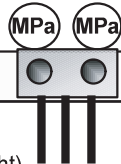

Attention!!

Strainer normally does not have temperature difference between inlet and outlet as shown in (1), but if there is a difference like shown in (2), there is a possibility of inside clogged. In this case, replace Strainer.

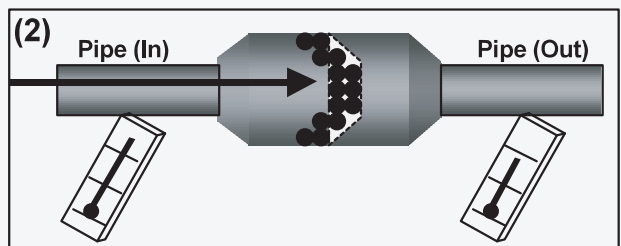
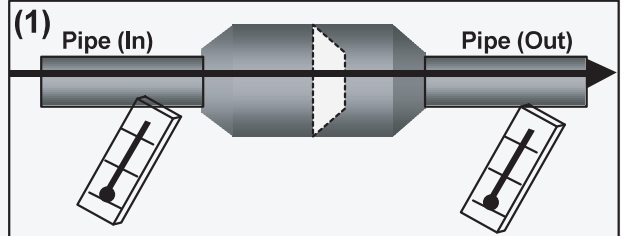

Trouble shooting 53

Abnormal Noise

Forecast of Cause :

1. Abnormal installation (Indoor/Outdoor)
2. Fan failure(Indoor/Outdoor)
3. EEV failure (Indoor)
4. Compressor failure (Outdoor)

Diagnosis method when Abnormal Noise is occurred

Abnormal noise is coming from Indoor Unit
(Check and correct followings)

- Is Main Unit installed in stable condition?
- Is the installation of Air suction grille and front panel normal?
- In case of Duct type : Is Static Pressure range normal?
(Refer to Data & Technical Manual)

OK

- Is Fan broken or deformed?
- Is the screw of Fan loose?
- Is there any object which obstruct the Fan rotation?

Attention!!

- If Refrigerant Noise is occurring, Check if the Indoor and Outdoor Thermistor is wrongly installed. Check and correct the thermistor.
- Check the refrigerant additional charging amount. When the refrigerant is not enough, add the refrigerant. However, the total refrigerant amount is prevented from more than 15.7kg.

Abnormal noise is coming from Outdoor Unit
(Check and correct followings)

- Is Main Unit installed in stable condition?
- Is Bell Mouth installed normally?

OK

- Is Fan broken or deformed?
- Is the screw of Fan loose?
- Is there any object which obstruct the Fan rotation?

OK

- Check if vibration noise by loose bolt or contact noise of piping is happening.

OK

- Is Compressor locked?
>> Check Compressor (Refer to Service Parts Information)

Trouble shooting 54

Water Leaking

Forecast of Cause :

1. Erroneous installation
2. Drain hose failure
3. Float Switch failure

Diagnosis method when water leak occurs

- Is Main Unit installed in stable condition?
- Is Main Unit broken or deformed at the time of transportation or maintenance?

OK

- Is Drain Hose connection loose?
- Is there a trap in Drain Hose?
- Is Drain Hose clogged?

OK

- Is Fan rotating?
>> Check Fan Motor (Refer to Service Parts Information)

OK

- Is Float Switch defective?
>> Check Float Switch (Refer to Trouble Shooting)

Diagnosis method when water is spitting out

- Is the filter clogged?

OK

- Check Gas Pressure and correct it if there was a gas leak.

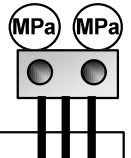

Attention!!

If water is leaking from the Indoor Unit that is not in operation, there is a possibility of Indoor EEV is not closed.

=> Check EEV (Refer to Service Parts Information)

4-3-3 Trouble Shooting for Optional Parts

1. External Switch Controller (UTY-TEKX)

Trouble shooting 55

Error Contents :
Power Supply Error

Symptom :
No operation & LED does not light up.

Condition :

1. No power supply.
Voltage error between red and black terminals of External Switch Controller. (Normal voltage: 12V plus minus 10%)
2. Electric circuit error.
Voltage is normal between red and black terminals of External Switch Controller (Normal voltage: 12V plus minus 10%)

Cause 1 : Indoor unit defective

- Refer to Indoor unit trouble shooting.

OK

Cause 2 : Connection cable is defective or open.

- Check installation of connection cable.
- Check if connection cable is open.

OK

Cause 3 : Defective insertion or open connection of the cable between External Switch Controller terminal and PCB.

- Check connector insertion.
- Check if connection cable is open.

OK

Cause 4 : Ext. Switch Controller is defective.

► **Replace External Switch Controller,**

Trouble shooting 56

Error Contents :
The abnormality in connection of remote controller cable

Symptom :
LED repeats flashing 0.5sec ON & 0.5sec OFF.

Condition :

Communication with Indoor unit has been cut off for longer than 1 minute.

Cause 1 :
Communication cable is defective or open.

- Check installation of connection cable.
- Check if connection cable is open.

OK

Cause 2 : Defective insertion or open connection of the cable between External Switch Controller terminal and PCB.

- Check connector insertion.
- Check if connection cable is open.

OK

Cause 3 : DIP switch setting defective

- Check setting of DIP-SW1-4, 1-5, 1-6.

OK

Cause 4 : External noise

- Remove or shut out external noise source.

OK

Cause 5 : Ext. Switch Controller is defective.

► **Replace External Switch Controller,**

Trouble shooting 57

Error Contents :
Transmission Error

Symptom :
LED repeats flashing 0.5sec ON & 1.0sec OFF.

Condition :

Normal communication with Indoor unit has been suspended for longer than 1 minute.

Cause 1 : DIP switch setting defective

- Check setting of DIP-SW1-4, 1-5, 1-6.



Cause 2 : External noise

- Remove or shut out external noise source.

OK

Cause 3 : Ext. Switch Controller is defective.

- ▶ **Replace External Switch Controller,**

Trouble shooting 58

Error Contents :
Switch Operation Error

Symptom :
LED is lighting but Switch (SW1 or SW2) does not operate.

Condition :

Switch input can not be detected.

Cause 1 : Connection cable is defective or open.

- Check installation of connection cable.
- Check if connection cable is open.



Cause 2 : Defective insertion or open connection of the cable between External Switch Controller terminal and PCB.

- Check connector insertion.
- Check if connection cable is open.



Cause 3 : DIP switch setting defective

- Check DIP Switch setting.

OK

Cause 4 : External Switch is defective

- Check any short or switch operation failure.
- Check resistance value between the terminals, at the time of input.
- ▶ **OPEN** : More than 50 kΩ
- ▶ **SHORT** : Less than 1 kΩ

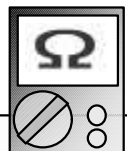

Cause 5 : Ext. Switch Controller is defective.

- ▶ **Replace External Switch Controller,**

2. Signal Amplifier (UTY-VSGX)

Trouble shooting 59

Error Contents :
Power Supply Error

Symptom :
No display

Details :

Condition of occurrence : Normal power is not supplied. 7 segment indicator is defective.

Release condition : Normal power is supplied. 7 segment indicator is normal.

Cause 1 :

Power supply cable installation is defective or open.

- Check following installation and reset the power supply.
- (1) Installation of power cable on power supply terminal.
- (2) Connection between Power PCB and Terminal.
- (3) Connector condition between power PCB and Main PCB.

OK

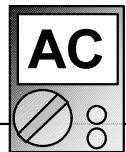

Cause 2 : Signal Amplifier is defective.

If normal voltage (Rated Voltage) is applied to power supply terminal of Signal Amplifier, there is a possibility of defective PCB. Proceed as follows.

► **Replace Signal Amplifier.**

Trouble shooting 60

Error Contents :
Communication Error

Symptom :
Error code does not appear [_]
Communication error occurs at connected equipment side.

Details :

Condition of occurrence : Network cable defective. External noise is applied.

Overlapping of Signal Amplifier address setting. System design mistake.

Release condition : Network cable is connected. External noise is removed.

Overlapping of Signal Amplifier has been corrected. System design is normal.

Cause 1 :

Network cable installation is defective or open.

- Check Network cable installation.

OK

Cause 2 : External noise

- Remove external noise around Signal Amplifier or Network cable. (Keep enough distance)

OK

Cause 3 :

Overlapped address of Signal Amplifier.

- Set up address again which does not overlap on system. After set up again, reset the power supply.

OK

Cause 4 : System Design mistake

- Check following items.(Refer to Installation Manual)
- (1) Installation location of Terminal Resistor.
(Only 1 location on NS*)
- (2) Cable length. (Within 500m maximum on NS*)
- (3) Number of units connected
(Up to 64 units maximum on NS*)
- (4) Communication cable specification.
(Use specified type.)
- (5) Number of Signal Amplifier installed.
(Up to 8 units max. on system)
- (6) Network cable shall not be connected in loop.

*NS : Network Segment

Trouble shooting 61

Error Contents :
Address Setting Error

Symptom :
Error display [2 6]
No operation.

Details :

Condition of occurrence : Address is not set at Signal Amplifier.

Release condition : Address setting mode is started up, and desired address has been set up.

Cause 1 : External noise

- Upon pressing RESET button (SW7) or turning on power, proceed as follows.
- (1) If error did not appear, it is not a defect of PCB. Remove the surrounding noise source.
- (2) If error occurs again, check followings other than removing surrounding noise source.

OK

Cause 2 : Address is not set at Signal Amplifier.

- Set up address again.
After set up again, reset the power supply.

OK

Cause 3 : Signal Amplifier is defective.

- ▶ **Replace Signal Amplifier.**

Trouble shooting 62

Error Contents :
Parallel Communication Error

Symptom :
Error display [C 1]
No operation.

Details :

Condition of occurrence : Communication error between CPU and Network Driver IC

Release condition : Communication is normal between CPU and Network Driver IC

Cause 1 : External noise

- Upon pressing RESET button (SW7) or turning on power, proceed as follows.
- (1) If error did not appear, it is not a defect of PCB. Remove the surrounding noise source.
- (2) If error occurs again, check followings other than removing surrounding noise source.

OK

Cause 2 : Signal Amplifier is defective.

- ▶ **Replace Signal Amplifier.**

Trouble shooting 63

Error Contents :
Communication Error B

Symptom :
Error display [D9 (Flashing or Lighting)]
No operation.

Details :

Condition of occurrence : Communication error between CPU and Network Driver IC (CH_B side).
Network Driver IC is defective.
Release condition : Communication is normal between CPU and Network Driver IC (CH_B side).
Network Driver IC operation is normal.

Cause 1 : External noise

- Upon pressing RESET button (SW7) or turning on power, proceed as follows.
- (1) If error did not appear, it is not a defect of PCB. Remove the surrounding noise source.
- (2) If error occurs again, check followings other than removing surrounding noise source.

OK

Cause 2 :Signal Amplifier is defective.

► **Replace Signal Amplifier.**

Trouble shooting 64

Error Contents :
Communication Error A

Symptom :
Error display [D14 (Flashing or Lighting)]
No operation.

Details :

Condition of occurrence : Communication error between CPU and Network Driver IC (CH_A side).
Network Driver IC is defective.
Release condition : Communication is normal between CPU and Network Driver IC (CH_A side).
Network Driver IC operation is normal.

Cause 1 : External noise

- Upon pressing RESET button (SW7) or turning on power, proceed as follows.
- (1) If error did not appear, it is not a defect of PCB. Remove the surrounding noise source.
- (2) If error occurs again, check followings other than removing surrounding noise source.

OK

Cause 2 : Signal Amplifier is defective.

► **Replace Signal Amplifier.**

3. Network Convertor (UTY-VGGX)

1. When connecting a group remote controller to a network convertor

Trouble shooting 65

Error Contents :
Power Supply Error

Symptom :
No display

Details :

Condition of occurrence : Normal power is not supplied. 7 segment indicator is defective.
Release condition : Normal power is supplied. 7 segment indicator is normal.

Cause 1 :
Power supply cable installation is defective or open.

- Check following installation and reset the power supply.
- (1) Installation of power cable on power supply terminal.
- (2) Connection between Power PCB and Terminal.
- (3) Connector condition between power PCB and Main PCB.

OK

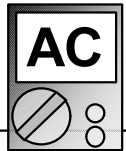

Cause 2 : Network Convertor is defective.

If normal voltage (Rated Voltage) is applied to power supply terminal of Network Convertor, there is a possibility of defective PCB. Proceed as follows.

► **Replace Network Convertor.**

Trouble shooting 66

Error Contents :
PCB Error 1

Symptom :
Error Code display [C 1]
All the control items do not operate.

Details :

Condition of occurrence : Synchronization of Network Device was not normally done.
Release condition : When the synchronization of the device is normally done.

Cause 1 : External noise

- After pressing SW104 of Network Convertor PCB for 5 seconds or turning on power.
Does error code display reappear?

YES

- Remove the surrounding noise source.

NO

- It is not a defect of PCB. Remove the surrounding noise source.

OK

Cause 2 : Network Convertor is defective.

► **Replace Network Convertor.**

Trouble shooting 67

Error Contents :
**Communication Error
with Group Remote Controller**

Symptom :
**Error Code display [1 2] Control/Display from Group Remote is
not available.**

Details :

Condition of occurrence : The communication between Group Remote and Network Converter was not normally performed.
Release condition : When the communication between Group Remote and Network Converter resumes normal operation.

Cause 1 : External noise

After pressing SW104 of Network Converter PCB for 5 seconds or turning on power.
Does error code display reappear?

↓ YES

- Remove the surrounding noise source.

↓ OK

↓ NO

- It is not a defect of PCB. Remove the surrounding noise source.

Cause 2 :

Defective or open connection of cable wire between Network Converter and Connected Remote Controller.

After the following are checked, the power supply is reset.

- Check connection cable wire between Network Converter and Connected Remote Controller.
- Check connection between Control PCB and Terminal.

↓ OK

Cause 3 : Incorrect setting of Network Converter's DIP-SW103[1 to 4] (For Converter setting of Group Remote Controller)

- Check Network Converter PCB DIP-SW103[1 to 4] ON.

↓ OK

Cause 4 : Defective Remote Controller or Network Converter.

- ▶ **Replace Remote Controller or Network Converter.**

Trouble shooting 68

Error Contents :
Software Error

Symptom :
Error Code display [C A]
All the control items do not operate.
Other Controls are left they are.

Details :

Condition of occurrence : Micon program performed an abnormal control.
Error of inside information of EEPROM.
initial setting of Network Converter PCB was not normally performed.
Release condition : Micon has been reset, and the control of Network Converter became normal.
When error disappeared and Network Converter becomes available to control.

Cause 1 : External noise

Check continuation of error.
(1) If error is released automatically, it is not a defect of PCB. Remove the surrounding noise source around Network Converter.
(2) If error is not released automatically, check followings.

↓ OK

After pressing SW104 of Network Converter PCB for 5 seconds or turning on power.
Does error code display reappear?

↓ YES

• Remove the surrounding noise source.

↓ NO

• It is not a defect of PCB. Remove the surrounding noise source.

↓ OK

Cause 2 : Network Converter is defective.

▶ **Replace Network Converter.**

Trouble shooting 69

Error Contents :
Refrigerant circuit address setting error

Symptom :
Error Code display [2 6]

Details :

Condition of occurrence : Indoor unit registration is 3 refrigerant circuits or more.
Release condition : Indoor unit registration is 2 refrigerant circuits or less.

Cause 1 : Check of number of indoor unit registration refrigerant circuits

Check indoor unit registration.
(1) Number of refrigerant circuits of indoor unit registered at Replace Group Remote Controller is 3 refrigerant circuits or more even though connected to one converter.

↓ YES

Make 2 refrigerant circuits or less and wait 2 minutes

↓ NO

Replace Network Converter
Replace Group Remote Controller

3. Network Converter (UTY-VGGX)

2. When connecting a single split type indoor unit to a network converter

Trouble shooting 70

Error Contents :
Power Supply Error

Symptom :
No display

Details :

Condition of occurrence : Normal power is not supplied. 7 segment indicator is defective.
Release condition : Normal power is supplied. 7 segment indicator is normal.

Cause 1 :
Power supply cable installation is defective or open.

- Check following installation and reset the power supply.
- (1) Installation of power cable on power supply terminal.
- (2) Connection between Power PCB and Terminal.
- (3) Connector condition between power PCB and Main PCB.

OK

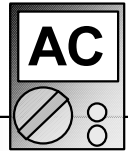

Cause 2 : Network Converter is defective.

If normal voltage (220V) is applied to power supply terminal of Network Converter, there is a possibility of defective PCB. Proceed as follows.
▶ **Replace Network Converter.**

Trouble shooting 71

Error Contents :
PCB Error 1

Symptom :
Error Code display [C 1]
All the control items do not operate.

Details :

Condition of occurrence : Synchronization of Network Device was not normally done.
Release condition : When the synchronization of the device is normally done.

Cause 1 : External noise

- After pressing SW104 of Network Converter PCB for 5 seconds or turning on power.
Does error code display reappear?

YES

NO

- Remove the surrounding noise source.

- It is not a defect of PCB. Remove the surrounding noise source.

OK

Cause 2 : Network Converter is defective.

▶ **Replace Network Converter.**

Trouble shooting 72

Error Contents :

**Communication Error
with Standard Remote Controller**

Symptom :

**Error Code display [1 2] Control/Display from Standard Remote s
not available. Other controls are left as they are.**

Details :

Condition of occurrence : The communication between Standard Remote Controller and Network Converter was not normally performed.

Release condition : When the communication between Standard Remote Controller and Network Converter resumes normal operation.

Cause 1 : External noise

- After pressing SW104 of Network Converter PCB for 5 seconds or turning on power.
Does error code display reappear?

↓ YES

- Remove the surrounding noise source.

↓ OK

↓ NO

- It is not a defect of PCB. Remove the surrounding noise source.

Cause 2 :

Defective or open connection of cable wire between Network Converter and Connected Remote Controller.

After the following are checked, the power supply is reset.

- Check connection cable wire between Network Converter and Connected Remote Controller.
- Check connection between Control PCB and Terminal.

↓ OK

Cause 3 : Incorrect setting of Network Converter's DIP-SW107[2] (Wired RC Validity setting)

- Check Network Converter PCB DIP-SW107[2].

↓ OK

Cause 4 : Incorrect selection of Remote Controller

- Check connection Remote Controller. (Is it specified with the Installation Manual of Network Converter?)

↓ OK

Cause 5 :

Incorrect setting of Remote Controller's DIP-SW (Number of connected remote controllers)

- Check DIP-SW of Remote Controller.

↓ OK

Cause 6 : Defective Remote Controller or Network Converter.

- ▶ **Replace Remote Controller or Network Converter.**

Trouble shooting 73

Error Contents :
**Communication Error
with Indoor Unit**

Symptom :
**Error Code display [1 6]
All the control items do not operate.**

Details :

Condition of occurrence : The communication between Indoor unit and Network Converter was not performed normally.

Release condition : When the communication with Indoor unit is resumed normally.

Cause 1 : External noise

After pressing SW104 of Network Converter PCB for 5 seconds or turning on power.
Does error code display reappear?

YES

NO

● Remove the surrounding noise source.

● It is not a defect of PCB. Remove the surrounding noise source.

OK

Cause 2 :

Defective or open connection of Remote Control cable between Network Converter and Indoor Unit.

After the following are checked, the power supply is reset.

- Check connection cable wire between Network Converter and Indoor unit.
- Check connection between Control PCB and Terminal.

OK

Cause 3 : Power to Indoor unit is shut down.

- Check the power to Indoor unit.

OK

Cause 4 : Incorrect setting of main unit address of Indoor unit.

- Check main unit address setting of Indoor unit.

OK

Cause 5 : Incorrect setting of DIP-SW of Network Converter. Mis-read of Indoor unit type and RC type.

- Check DIP-SW103[1 to 8] of Network Converter (Indoor unit type, RC type, number of Indoor units connected.)
- Check Indoor unit type and RC type of all Indoor units connected to Network Converter.

OK

Cause 6 : Defective PCB of Indoor unit or Network Converter.

- ▶ **Replace PCB of Controller PCB or Network Converter.**

Trouble shooting 74

Error Contents :
**Communication Error
with Indoor Unit**

Symptom :
**Error Code display [2 6]
All the control items do not operate.**

Details :

Condition of occurrence : The communication between Indoor unit and Network Converter was not performed normally.
Release condition : When the communication with Indoor unit is resumed normally.

Cause 1 : External noise

After pressing SW104 of Network Converter PCB for 5 seconds or turning on power.
Does error code display reappear?

↓ YES

- Remove the surrounding noise source.

↓ OK

↓ NO

- It is not a defect of PCB. Remove the surrounding noise source.

Cause 2 : Defective or open connection of Remote Control cable between Network Converter and Indoor Unit.

After the following are checked, the power supply is reset.
 Check connection cable wire between Network Converter and Indoor unit.
 Check connection between Control PCB and Terminal.

↓ OK

Cause 3 : Power to Indoor unit is shut down.

Check the power to Indoor unit.

↓ OK

Cause 4 : Incorrect setting of main unit address of Indoor unit.

Check main unit address setting of Indoor unit.

↓ OK

Cause 5 : Incorrect setting of DIP-SW of Network Converter. Mis-read of Indoor unit type and RC type.

Check DIP-SW103[1 to 8] of Network Converter (Indoor unit type, RC type, number of Indoor units connected.)
 Check Indoor unit type and RC type of all Indoor units connected to Network Converter.

↓ OK

Cause 6 : Defective PCB of Indoor unit or Network Converter.

▶ **Replace PCB of Controller PCB or Network Converter.**

Trouble shooting 75

Error Contents :
Software Error

Symptom :
Error Code display [C A]
All the control items do not operate.
Other Controls are left they are.

Details :

Condition of occurrence : Micon program performed an abnormal control.
Error of inside information of EEPROM.
initial setting of Network Converter PCB was not normally performed.
Release condition : Micon has been reset, and the control of Network Converter became normal.
When error disappeared and Network Converter becomes available to control.

Cause 1 : External noise

- Check continuation of error.
- (1) If error is released automatically, it is not a defect of PCB. Remove the surrounding noise source around Network Converter.
- (2) If error is not released automatically, check followings.

↓ OK

- After pressing SW104 of Network Converter PCB for 5 seconds or turning on power.
Does error code display reappear?

↓ YES

- Remove the surrounding noise source.

↓ NO

- It is not a defect of PCB. Remove the surrounding noise source.

↓ OK

Cause 2 : Network Converter is defective.

- ▶ **Replace Network Converter.**

Trouble shooting 76

Error Contents :
Indoor / Outdoor Unit Error

Symptom :
Error Code display [5 U]
Other controls are left as they are.

Details :

Condition of occurrence : When error occurred on Indoor/Outdoor unit that is connected to Network Converter.
Release condition : When the error of Indoor/Outdoor unit that is connected to Network Converter is released.

Cause 1 : Error occurred in Indoor unit

- ▶ **Refer to Indoor Unit trouble shooting.**
(Removal of error of indoor unit connected to network converter)

↓ OK

Cause 2 : Error occurred in Outdoor unit

- ▶ **Refer to Outdoor Unit trouble shooting.**
(Removal of error of outdoor unit connected to network converter)

4. Group Remote Controller (UTY-CGGY / CGGG)

Trouble shooting 77

Error Contents :
PCB Error

Symptom :
Error Code display [C 4]
OPERATION LED is flashing.

Details :

Condition of occurrence : When EEPROM can not be written, or the control port does not operate.
Release condition : Power is reset.

Cause 1 : Remote Controller is defective.

► **Replace Group Remote Controller.**

Trouble shooting 78

Error Contents :
Connection Error

Symptom :
Error Code display [1 2]
OPERATION LED is flashing.

Details :

Condition of occurrence :

The valid signal has not been received from the convertor more than 90 seconds after the communication line became valid.

Release condition : Valid signal is received from Convertor.

Cause 1 : Connection failure

- Check power to the convertor.
- Check connection of remote control line between controller and convertor.



Cause 2 : Check outside cause (Voltage drop or noise, etc.)

- Instant drop ---- Check if there is a large load electric apparatus in the same circuit.
- Momentary power failure ---- Check if there is a defective contact or leak current in the power supply circuit.
- Noise ---- Check if there is any equipment causing harmonic wave near electric line (Neon bulb or electric equipment that may cause harmonic wave).



Cause 3 : Remote Controller is defective.

- ▶ **Replace Group Remote Controller.**

Trouble shooting 79

Error Contents :
Address Setting Error

Symptom :
Error Code display [2 6]
OPERATION LED is flashing.

Details :

Condition of occurrence :

1. No Indoor unit is registered.

Release condition :

1. The key to enter the function selection process is pressed.
TIME< key and TIME> key are simultaneously kept pressed.
2. It automatically initializes by itself. After that, it is released by pressing the key to enter the function selection process.

Cause 1 : Setting failure

- Register Indoor units again by entering to the function selection mode.
(Keep pressing TIME< key and TIME> key.
(Refer to the installation manual for the remote controller.)

Trouble shooting 80

Error Contents : System Error

Symptom :

Error Code display [1 5]
OPERATION LED is flashing.

Details :

Condition of occurrence :

1. Registration started within 4 minutes after power ON
2. Indoor unit refrigerant system registered at controller connected to converter reached 3 or more ([26] error generated at converter)
3. Only the slave unit is registered. (Main unit is not registered.)
4. Indoor unit which is not existing was registered.
5. Outdoor unit is not set in the same refrigerant circuit as the indoor unit.

Release condition : Registered contents have been changed by SELECT key, DAY key, Timer Mode key (DELETE key).

Cause 1 : Conditions check

- Check if 4 minutes or more after starting
- Clear when [26] error generated at converter.
- Check if refrigerant systems do not become 3 or more by this indoor unit registration.



Cause 2 : Setting failure

- Recheck the registered contents.(Register the main unit.)
- Check Indoor unit DIP-SW, R-SW
- Check outdoor unit R-SW.



Cause 3 : Connection failure

- Check transmission cable
- Check if Indoor or Outdoor unit power line is disconnected.
- Check if the convertor power line is disconnected.
- Check connection between controller and the convertor.



Cause 4 : Check outside cause (Voltage drop or noise, etc.)

- Instant drop ----- Check if there is a large load electric apparatus in the same circuit.
- Momentary power failure ----- Check if there is a defective contact or leak current in the power supply circuit.
- Noise ----- Check if there is any equipment causing harmonic wave near electric line (Neon bulb or electric equipment that may cause harmonic wave).



Cause 5 : Remote Controller is defective.

- ▶ **Replace Group Remote Controller.**

Trouble shooting 81

Error Contents :
Transmission Error

Symptom :
Error Code display [1 4]
OPERATION LED is flashing.

Details :

Condition of occurrence :

When the signal is cut off for more than 10 minutes from the registered Indoor unit (not including Slave unit).

Release condition : 1. The signal has been received from the Indoor units that was creating the error.

2. MPU has been booted up. (Release from the reset operation, the power failure stand-by operation.)

Cause 1 : Connection failure

- Check transmission cable
- Check disconnected power line for Indoor unit.
- Check if convertor power line is disconnected.



Cause 2 : Check outside cause (Voltage drop or noise, etc.)

- Instant drop ----- Check if there is a large load electric apparatus in the same circuit.
- Momentary power failure ----- Check if there is a defective contact or leak current in the power supply circuit.
- Noise ----- Check if there is any equipment causing harmonic wave near electric line (Neon bulb or electric equipment that may cause harmonic wave).



Cause 3 : Remote Controller is defective.

- ▶ Replace Group Remote Controller.

5. Wired Remote Controller (UTY-RNK*)

Trouble shooting 82

Error Contents :
Thermo Sensor Error

Symptom :
Thermostat Sensor display is flashing.

Details :

Condition of occurrence : Thermistor in remote controller is open or shorted.

Release condition : Thermistor in remote controller is not open or shorted.

Cause 1 : Remote controller internal thermistor trouble

- Replace remote controller.

6. Wired(UTY-RNK*) and Simple Remote Controller (UTY-RSK*,RHK*)

Trouble shooting 83

Error Contents :
Indoor Unit ↔ Remote Controller
Communication Error

Symptom :
Error Code display [1 2]

Details :

Condition of occurrence : When signal from indoor unit does not enter
Release condition : When signal from indoor unit entered

Cause 1 : Check connection

- Check cable
- Check indoor unit power supply

↓
OK

Cause 2 : Check indoor unit remote controller address.

- Check if the indoor unit remote controller addresses are sequentially set from 0.

↓
OK

Cause 3 : Noise

- Remove the surrounding noise.

↓
OK

Cause 4 : Remote controller trouble

- Replace remote controller.

↓
OK

Cause 5 : Indoor unit PCB trouble

- Change Controller PCB and set up the original address.

Trouble shooting 84

Error Contents :
Incompatible Indoor Unit is Connected

Symptom :
Error Code display [1 5]

Details :

Condition of occurrence : When information was not obtained from indoor unit
Release condition : When information was obtained from indoor unit

Cause 1 : Check remote controller master/slave setting.

- For the check and modification methods, refer to the remote controller (including external SW) installation manual.
- When there is 1 remote controller, check whether or not it is set as the master remote controller.
- When there are 2 remote controllers, check if one side is the master remote controller and the other side is the slave remote controller.
- When there are 1 remote controller and 1 external switch controller, check if the remote controller is master controller and the external switch controller is slave controller.



Cause 2 : Check connection

- Check cable
- Check indoor unit power supply



Cause 3 : Noise

- Source around cable



Cause 4 : Remote controller trouble

- Replace remote controller.



Cause 5 : Indoor unit PCB trouble

- Change Controller PCB and set up the original address.

7. System Controller (UTY-APGX) / Service Tool (UTY-ASGX) / Web Monitoring Tool (UTY-AMGX)
(Referred to as "Service Tool" hereafter)

Trouble shooting 85

Error Contents :
Unit Not Detected

Symptom :

1 or more units (but not all) are not detected after Scan.
1 or more units (but not all) are not listed in the system list after Scan.

Details :

Condition of occurrence:

- Unit address is not set correctly.
- Network cable is not connected correctly.
- System design is mistaken.
- Unit transmission board is defective.

Recovery condition:

- Unit address is set correctly.
- Network cable is connected as designed.
- System design and work is corrected.
- Unit transmission board is normal.

Cause 1 : Unit address is not set correctly.

- Check the unit address setting of the undetected unit and correct it if mistaken.



Cause 2 : Network cable is not connected as designed.

- Check that the network cables are connected according to the site design drawing.
Check specifically the network segment where the undetected unit exists.
- Check and fix the loose cable connection to the terminal of the undetected unit.
- Using Service Tool, perform scan changing the network segment where the Service Tool is connected and localize the mistaken network segment. Start from the network segment where the undetected unit exists.
Specify priority scan when possible.



Cause 3 : System design work is mistaken.

- Check the following items and fix appropriately if mistaken.
 - (1) 1 (and only 1) Terminal Resistor is connected for each network segment.
 - (2) Cable length is within 500m for each network segment.
 - (3) Number of units connected within a network segment does not exceed 64.
(1 connected port of Signal Amplifier is counted as 1).
 - (4) Network cable specification is as specified in the Design & Technical Document.
 - (5) Total number of Signal Amplifiers does not exceed 8 per system.
 - (6) Network cable is not connected in loop.
 - (7) Both ends of the network cable are grounded.
 - (8) Network cables are not bundled together with power cables to prevent noise induction.



Cause 4 : Unit transmission board is defective.

- Replace transmission board of the undetected unit if none of the above cause applies.

Note :

A Network Segment is a portion of the network connected directly by network cables and is separated by Signal Amplifiers. If no Signal Amplifier exists, there is only 1 network segment.

Trouble shooting 86 INDOOR UNIT Error Method: Address setting Error in Wired remote controller system	Indicate or Display: Outdoor Unit : E.5 U.1 Indoor Unit : Operation LED 2 times Flash, Timer LED 6 Times Flash, Filter LED Continuous Flash. Error Code : 2 6
---	---

Detective Actuators: Wired remote controller (2-Wire) Indoor unit Controller PCB circuit	Detective details: When the address number set by auto setting and manual setting are mixed in one RC group. When the duplicated address number exists in one RC group.
---	--

Forecast of Cause : 1. Wrong wiring of RCgroup 2. Wrong remote address setting 3. Indoor unit controller PCB failure
4. Remote controller failure

Check Point 1 : Wire installation

- Wrong wire connection in RCgroup (Please refer to the installation manual)



Check Point 2 : Wrong RCgroup setting

- The given address number by auto setting (00) and the manual set number (Except 00) were not existing in one RCG.
- The remote controller address setting by U.I. were not existing same address.
- The duplicated address number is not existing in one RCgroup



Check Point 3 : Check Indoor unit controller PCB

- Check if controller PCB damage
- Change controller PCB and check the Error after setting remote controller address

Trouble shooting 100 INDOOR UNIT Error Method: Indoor Unit power supply error for FAN motor 1 (2)	Indicate or Display: Outdoor Unit : E.5 U.1 Error Code : 3 9 , 3 9 . 1 (2)
--	---

Detective Actuators: Indoor Unit Controller PCB Circuit Indoor Unit filter PCB Circuit	Detective details: When the DC power input for Fan motor < W500 - W501 (W530 - W531) on the Filter PCB> becomes lower voltage than the specified voltage.
---	---

Forecast of Cause : 1. Noise momentary open, voltage drop 2. Wire connection 3. Fan motor 4. Peripheral electric devices 5. Filter PCB 6. Controller PCB
--

Check Point 1 : Check if any outside cause such as voltage drop or noise <ul style="list-style-type: none"> ● Instant voltage drop ---- Check if there is any electric equipment with a large load within the same circuit. ● Momentary power failure ---- Check contact failure or leak current in power supply circuit ● Check if there is any equipment that causes harmonic wave near the power cable (Neon light bulb or any electronic equipment which causes harmonic wave). And check the complete insulation of grounding. >>If the same symptom does not reappear after resetting the power, possibility of noise is high.
--

↓
OK

Check Point 2 : Check wire connection <ul style="list-style-type: none"> ❑ Wire lose connection / damage between the CN21on the Controller PCB and CN250 on the Filter PCB In case of Model 72, between W530 (W531) on the filter PCB and capacitor. >>If there is abnormal on the wire, replace it
--

↓
OK

Check Point 3 : Check rotation of Fan / wire resistance <ul style="list-style-type: none"> ❑ Rotate the applicable fan by hand when operation is off. ❑ Disconnect the connector from the controller PCB and Check resistance value of Motor connector (Refer to the service parts information 13-2)
--

↓
OK

Check Point 4 : Check peripheral devices, Posistor, Capacitor, Diode bridge <ul style="list-style-type: none"> ❑ Check resistance value, short circuit, visible damage >>If there is abnormal , replace it
--

↓
OK

Check Point 5 : Replace Filter PCB <ul style="list-style-type: none"> ❑ Change filter PCB
--

↓
NG

Check Point 6 : Replace Controller PCB <ul style="list-style-type: none"> ❑ Change Controller PCB and set up the original address.

Trouble shooting 101 INDOOR UNIT Error Method: Indoor unit suction air temp. thermistor error	Indicate or Display: Outdoor Unit : E.5 U.1 Error Code : 4 A, 4 A. 1
---	---

Detective Actuators: Indoor Unit Controller PCB Circuit Suction air temp. Sensor	Detective details: When Indoor unit suction air temp. thermistor open or shortage is detected
---	---

Forecast of Cause : 1. Connector defective connection 2. Thermistor defective 3. Controller PCB defective

Check Point 1 : Check connection of Connector
<input type="checkbox"/> Check if connector is loose or removed <input type="checkbox"/> Check erroneous connection <input type="checkbox"/> Check if thermistor cable is open <u>>>Reset Power when reinstalling due to removed connector or incorrect wiring.</u>



Check Point 2 : Remove connector and check sensor resistance value									
Sensor Characteristics (Rough value)									
Temperature (°F)	32	41	50	59	68	77	86	95	
Temperature (°C)	0	5	10	15	20	25	30	35	
Resistance Value (kΩ)	33.6	25.2	20.1	15.8	12.5	10.0	8.0	6.5	
Temperature (°F)	104	113	122						
Temperature (°C)	40	45	50						
Resistance Value (kΩ)	5.3	4.3	3.5						
▶ If Thermistor is either open or shorted, replace it and reset the power.									

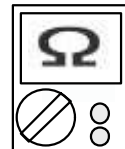

Check Point 3 : Check voltage CN9 of Controller PCB (DC5.0V)
▶ If the voltage does not appear, replace Controller PCB and set up the original address.



Trouble shooting 102 INDOOR UNIT Error Method: Indoor unit discharge air temp. thermistor error	Indicate or Display: Outdoor Unit : E.5 U.1 Error Code : 4 A, 4 A. 2
---	---

Detective Actuators: Indoor Unit Controller PCB Circuit Discharge air temp. Sensor	Detective details: When Indoor unit discharge air temp. thermistor open or shortage is detected
---	---

Forecast of Cause : 1. Connector defective connection 2. thermistor defective 3. Controller PCB defective

Check Point 1 : Check connection of Connector
<input type="checkbox"/> Check if connector is loose or removed <input type="checkbox"/> Check erroneous connection <input type="checkbox"/> Check if thermistor cable is open >>Reset Power when reinstalling due to removed connector or incorrect wiring.



Check Point 2 : Remove connector and check sensor resistance value									
Sensor Characteristics (Rough value)									
Temperature (°F)	32	41	50	59	68	77	86	95	
Temperature (°C)	0	5	10	15	20	25	30	35	
Resistance Value (kΩ)	33.6	25.2	20.1	15.8	12.5	10.0	8.0	6.5	
Temperature (°F)	104	113	122						
Temperature (°C)	40	45	50						
Resistance Value (kΩ)	5.3	4.3	3.5						
▶ If Thermistor is either open or shorted, replace it and reset the power.									



Check Point 3 : Check voltage CN9 of Controller PCB (DC5.0V)
▶ If the voltage does not appear, replace Controller PCB and set up the original address.



Troubleshooting 103 INDOOR UNIT Error Method: Indoor Unit Fan Motor 2 rotation speed Error	Indicate or Display: Outdoor Unit : E.5 U.1 Error Code : 5 9, 5 9. 2
---	---

Detective Actuators: Indoor Unit Controller PCB Circuit Indoor Fan Motor 2	Detective details: When the FAN motor feed back rotation value which is detecting on the controller PCB becomes 0 and lasts for more than 1 minute at motor operation condition. Or, when the feed back rotation value continues at 1/ 3 of target value for more than 1 minute.
---	---

Forecast of Cause : 1. Fan rotation failure 2. Fan motor winding open 3. Motor protection by ambient temp. increase
 4. Capacitor failure 5. Controller PCB failure

Check Point 1 : Check rotation of Fan

Rotate the fan by hand when operation is off.
 (Check if fan is caught, dropped off or locked motor)
>>If Fan or Bearing is abnormal, replace it.



Check Point 2 : Check Motor winding / Internal PCB circuit

Check Indoor Fan motor (Refer to the PARTS INFORMATION 13-2)
>>If Fan motor is abnormal, replace it.



Check Point 3 : Check ambient temp. around motor

Check excessively high temperature around the motor.
 (If there is any surrounding equipment that causes heat)
>>Upon the temperature coming down, restart operation..



Check Point 4 : Check Motor Capacitor

Check continuity of motor capacitor
>>If it is shorted, replace the capacitor.



Check Point 5 : Replace Controller PCB

Change Controller PCB and set up the original address.

Trouble shooting 104

Outdoor air unit - No Power

Forecast of Cause :

1. Power Supply failure
2. Outside cause
3. Electrical Component defective

Check Point 1 : Power supply

- Is not the breaker down?
- Instant drop ----- Check if there is a large load electric apparatus in the same circuit.
- Momentary power failure ----- Check if there is a defective contact or leak current in the power supply circuit.
- Noise ----- Check if there is any equipment causing harmonic wave near electric line (Neon bulb or electric equipment that may cause harmonic wave).
Check the complete insulation of grounding.

OK

OK (No short circuit)

Check Point 2 : Check Protector (20A)

- Check protector open / short
If the protector is open circuit, replace it.

OK (No short circuit)

Check Point 3 : Check AC line

- Check AC line (L-N) open / short

NG (Short circuit)

Check Point 4 : Check short circuit Filter PCB

- Disconnect the wire between Filter PCB and reactor, check short circuit of AC line.
If there is short circuit, replace the Filter PCB.

OK (No short circuit)

Check Point 5 : Check short circuit Diode bridge

- Connect the disconnected wire(s) on the check point 4, disconnect the wire between Diode bridge and Capacitor, check short circuit of AC line.
If there is short circuit, replace the Diode bridge.

OK (No short circuit)

Check Point 6 : Check short circuit Capacitor

- Connect the disconnected wire(s) on the check point 5, disconnect the wire between Capacitor and Filter PCB, check short circuit of AC line.
If there is short circuit, replace the Capacitor.

OK (No short circuit)

Check Point 7 : Check short circuit Power supply PCB

- Connect the disconnected wire(s) on the check point 6, disconnect the wire of Fan motor, check short circuit of AC line.
If there is short circuit, replace the Power supply PCB.

OK (No short circuit)

Check Point 8 : Check Fan Motor

- Check open / short of FAN motor
Refer to the Service Parts Information 13-2
If there is short circuit, replace FAN motor.

Check Point 9 : Short circuit check on DC circuit

- Disconnect the connector (CN200) on the Power supply PCB and check the short circuit
1. DC12V line (CN200 Pin 1 - 5)
 2. DC 5V Line (CN200 Pin 1 - 3)
 3. DC 15V-1 Line (CN500 Pin 3 - 4)
 4. DC 15V-2 Line (CN530 Pin 3 - 4)
- If one of them is short circuit, replace the Power supply PCB

OK (No short circuit)

Check Point 10 : Check short circuit of actuators (for DC12V)

- Disconnect the CN10 (EEV1) on the Main PCB, and check short circuit on Main PCB CN 4 Pin 1 - 5.
If the short circuit disappears, replace the EEV coil.
- Disconnect the CNC01 (WRC) on the Main PCB, and check short circuit on Main PCB CN 4 Pin 1 - 5.
If the short circuit disappears, check the WRC wire, WRC.
- Disconnect the CNB01 (Ext.Out) on the Main PCB, and check short circuit on Main PCB CN 4 Pin 1 - 5.
If the short circuit disappears, check the Ext. device or wiring.
- Disconnect the CN2 (TransmissionPCB) on the Main PCB, and check short circuit on Main PCB CN 4 Pin 1 - 5.
If the short circuit disappears, replace the Transmission PCB.
- Disconnect the CN22 (Interconnecting wire) on the Main PCB, and check short circuit on Main PCB CN 4 Pin 1 - 5.
If the short circuit disappears, replace the Filter PCB.
- If the short circuit appears after disconnecting actuators, replace the Main PCB.

OK (No short circuit)

Check Point 11 : Check short circuit of actuators (for DC5V)

- Disconnect the CN14 (SW PCB) on the Main PCB, and check short circuit on Main PCB CN 4 Pin 1 - 3.
If the short circuit disappears, replace the SW PCB.
- Disconnect the CN18 (Receiver unit *Option) on the Main PCB, and check short circuit on Main PCB CN 4 Pin 1 - 3.
If the short circuit disappears, check the wire, Receiver unit.
- Disconnect the CN2 (Transmission PCB) on the Main PCB, and check short circuit on Main PCB CN 4 Pin 1 - 3.
If the short circuit disappears, replace the Transmission PCB.
- Disconnect the CN21 (Interconnecting wire) on the Main PCB, and check short circuit on Main PCB CN 4 Pin 1 - 3.
If the short circuit disappears, replace the Power supply PCB.
- If the short circuit appears after disconnecting actuators, replace the Main PCB.

Trouble shooting 105 INDOOR UNIT Error Method: Connection unit number error (Indoor unit in Wired remote controller system)	Indicate or Display: Outdoor Unit : E.5 U.1 Indoor Unit : Operation LED 2 times Flash, Timer LED 9 Times Flash, Filter LED Continuous Flash. Error Code : 2 9
--	--

Detective Actuators: Wired remote controller (2-Wire) Indoor unit Controller PCB circuit	Detective details: When the number of connecting indoor units are out of specified rule.
---	--

Forecast of Cause : 1. Wrong wiring/ Number of I.U, RC in RCgroup 2. Indoor unit controller PCB defective

Check Point 1 : Wire installation
<input type="checkbox"/> Wrong number of connecting indoor unit



Check Point 2 : Check Indoor unit controller PCB
<input type="checkbox"/> Check if controller PCB damage <input type="checkbox"/> Change controller PCB and check the Error after setting remote controller address

Trouble shooting 106 INDOOR UNIT Error Method: Indoor unit communication circuit (WRC) microcomputers communication Error	Indicate or Display: Outdoor Unit : E.5 U.1 Indoor Unit : Operation LED 3 times Flash, Timer LED 10 Times Flash, Filter LED Continuous Flash. Error Code : 3 A
--	---

Detective Actuators: Wired remote controller (2-Wire) Indoor unit Controller PCB circuit	Detective details: When the indoor unit(s) detects the configuration of RCG abnormal or the indoor unit detects lack of primary -remote controller.
---	--

Forecast of Cause : 1. Terminal connection abnormal 2. Wired remote controller failure
 3. Indoor unit controller PCB defective

Check Point 1 : Check the connection of terminal

After turning off the power supply, check & correct the followings

- Indoor unit - Check the connection of terminal between remote control and indoor unit, or between Indoor units and check if there is a disconnection or short of the cable



Check Point 2 , 3: Check Indoor unit controller PCB

- Check terminal voltage of controller PCB connector CNC01 (Power supply for remote)
 - If DC12V, Remote control failure (Controller PCB is OK) >>> Replace Remote controller
 - If DC0V, Controller PCB failure (Remote is OK) >>> Replace Controller PCB

In case of re-installation is done due to removed connector or incorrect wiring, turn on the power again.

Trouble shooting 107 INDOOR UNIT Error Method: Coil 1 (Expansion valve) Error	Indicate or Display: Outdoor Unit : E.5U.1 Indoor Unit : Operation LED 5 times Flash, Timer LED 2 Times Flash, Filter LED Continuous Flash. Error Code : 5 2
---	---

Detective Actuators: Indoor unit controller PCB	Detective details: When the EEV1 drive circuit is open circuit
---	--

Forecast of Cause : <ol style="list-style-type: none"> 1. Wrong capacity setting 2. EEV1 coil lose connection 3. EEV1 wire(s) cut or pinched 4. Defective EEV1 coil 5. Controller PCB (DC 12V) output abnormal 6. Noise momentary open, voltage drop

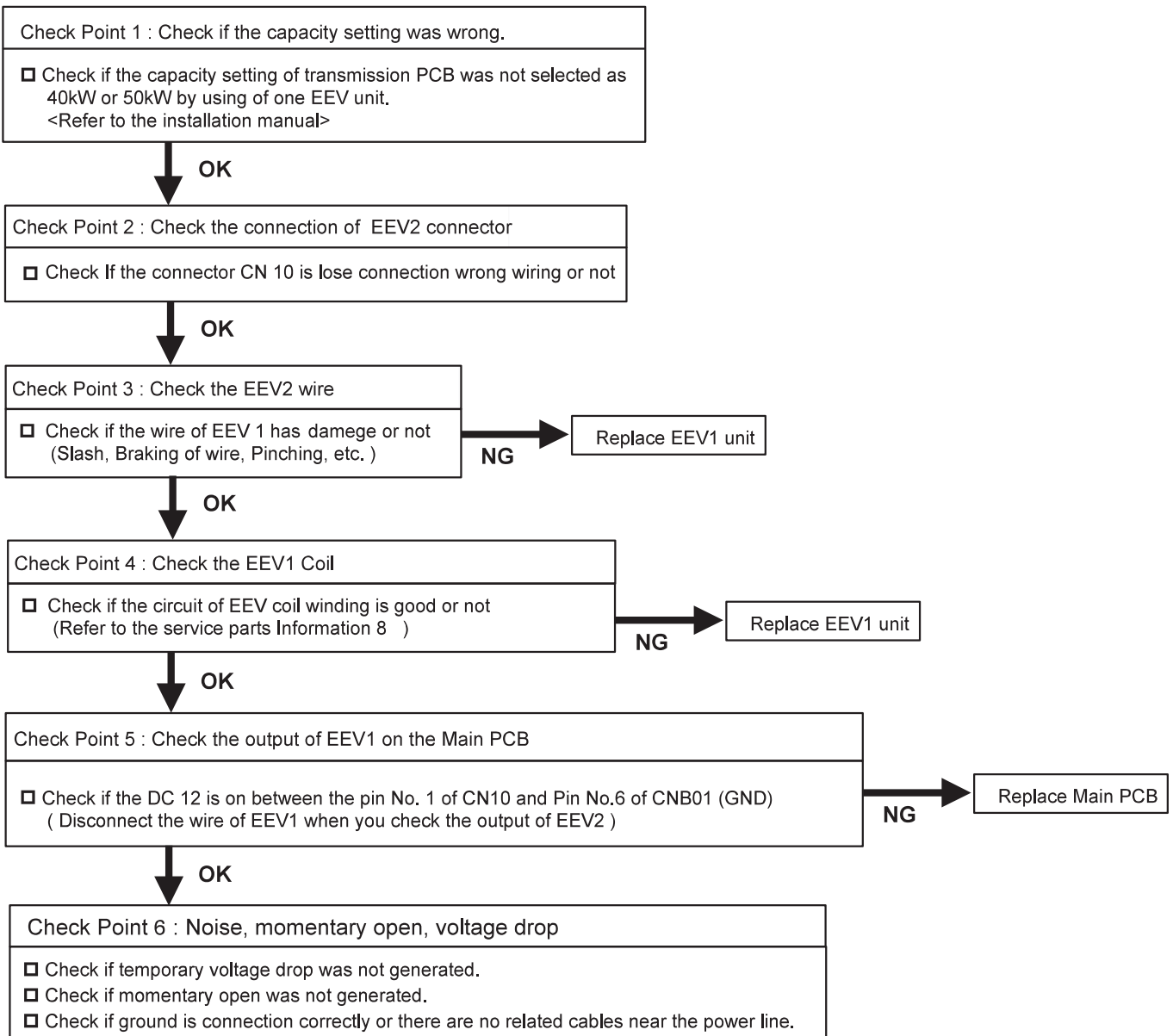

Trouble shooting 108 INDOOR UNIT Error Method: Coil 2 (Expansion valve) Error	Indicate or Display: Outdoor Unit : E.5U.1 Indoor Unit : Operation LED 5 times Flash, Timer LED 2 Times Flash, Filter LED Continuous Flash. Error Code : 5 2
---	---

Detective Actuators: Indoor unit controller PCB	Detective details: When the EEV2 drive circuit is open circuit
---	--

Forecast of Cause : <ol style="list-style-type: none"> 1. Wrong capacity setting 2. EEV2 coil lose connection 3. EEV2 wire(s) cut or pinched 4. Defective EEV2 coil 5. Controller PCB (DC 12V) output abnormal 6. Noise momentary open, voltage drop

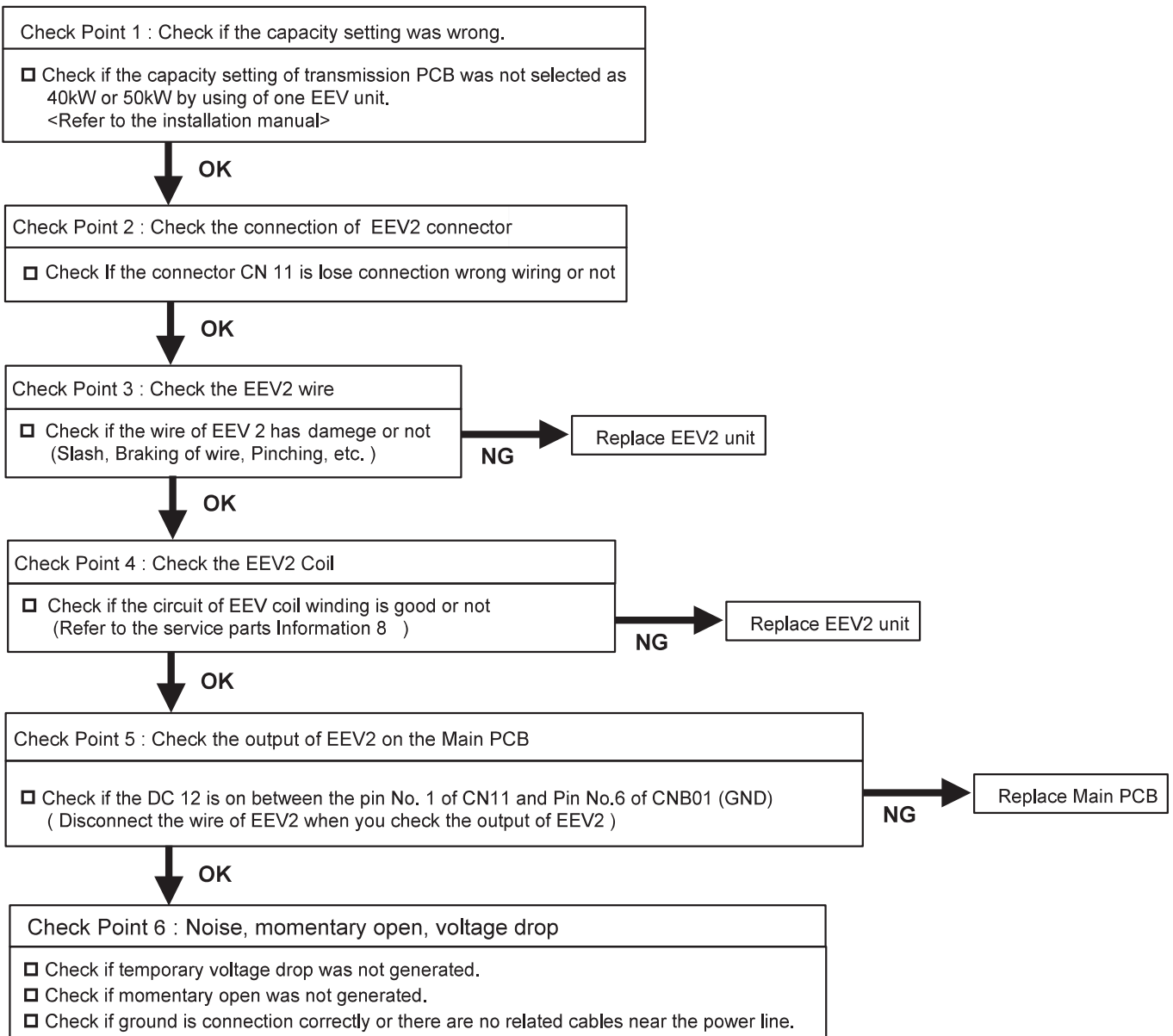

Trouble shooting 109 INDOOR UNIT Error Method: Peripheral device Error (DX-KIT Error)	Indicate or Display: Outdoor Unit : E.5U.1 Indoor Unit : Operation LED 13 times Flash, Timer LED 6 Times Flash, Filter LED Continuous Flash. Error Code : J 6
--	--

Detective Actuators: Peripheral device Error	Detective details: When the DX-KIT control unit received the Error input from Peripheral device Error
--	---

Forecast of Cause : 1. Error input connecting wire (When the External input Error input in use.) damage 2. Peripheral device Error

Check point 1: Check the wire connection of External input (Error input)
<input type="checkbox"/> Check wire between the terminal "Error input signal" of DX-KIT and the peripheral device, if it is not short circuit. If the connecting wire has the shorcircuit, replace the wire.

Check point 2: Check the Error status of peripheral device
<input type="checkbox"/> Refer to the Maintenance manual for the peripheral device.

* The type of error cannot be checked at the DX-KIT control unit.

Trouble shooting 110

Peripheral device doesn't operate
(No-power)

Forecast of Cause :

1. Power supply failuer
2. Trouble on peripheral device
3. DX-Kit Electrical component defective
4. Field setting mismatch

General check procedure

1. Check Error code on the VRF system. (Remote controller, Service tool, etc)
2. Check LED brinks on the controller PCB of DX-KIT
3. Check Error code on the peripheral device.
4. Check non of wrong filed settings or wrong installation.

Check Point 1 : Power supply

□ Is not the breaker down?

Instant drop ----- Check if there is a large load electric apparatus in the same circuit.

Momentary power failure ----- Check if there is a defective contact or leak current in the power supply circuit.

Noise ----- Check if there is any equipment causing harmonic wave near electric line (Neon bulb or electric equipment that may cause harmonic wave).

Check the complete insulation of grounding.

OK

Check Point 2: LED indication on the controller PCB

LED Brinking

Check Error code indication on the remote controller or Service tool

LED ON

Check Point 3: Operation signal output

Check circuit on the terminal ON /OFF SIGNAL(OUTPUT)

Short circuit

Refer to the service manual for the peripheral device and check the trouble shooting tips.

Open circuit

Check Point 4: Relay PCB power input DC12V

Check power input CN800 Pin1 - Pin2

OK (DC12V)

Make sure that the operation command (ON signal) is transferring from the controller to the DX-Kit controller.
If the ON singal was OK, Replace the Relay PCB.

NG

Make sure that the operation command (ON signal) is transferring from the Controller to the DX-Kit controller.
If the ON singal was OK, Replace the Main PCB.

Other tips

Check Field function setting, (External input signal setting)
The Prohibit setting condions
The operating mode mismatch

Trouble shooting 111

Peripheral device FAN does not operate

Forecast of Cause :

1. Power supply failuer
2. Trouble on peripheral device
3. DX-Kit Electrical component defective
4. Field setting mismatch

General check procedure

1. Check Error code on the VRF system. (Remote controller, Service tool, etc)
2. Check LED brinks on the controller PCB of DX-KIT
3. Check Error code on the peripheral device.
4. Check non of wrong filed settings or wrong installation.
5. Check if FAN operation stopped by the freeze prevention or the defrosting operation.

Check Point 1 : Power supply

□ Is not the breaker down?

Instant drop ----- Check if there is a large load electric apparatus in the same circuit.

Momentary power failure ----- Check if there is a defective contact or leak current in the power supply circuit.

Noise ----- Check if there is any equipment causing harmonic wave near electric line (Neon bulb or electric equipment that may cause harmonic wave).

Check the complete insulation of grounding.

OK

Check Point 2: LED indication on the controller PCB

LED Brinking

Check Error code indication on the remote controller or Service tool

LED ON

Check Point 3: Operation signal output

Check circuit on the terminal ON /OFF SIGNAL (OUTPUT)

Open circuit

Short circuit

Check Point 4: FAN SIGNAL output

Check circuit on the terminal FAN SIGNAL (OUTPUT)

Short circuit

Refer to the service manual for the prepheral device and check the trouble shooting tips.

Open circuit

Check Point 4: Relay PCB pwer input DC12V

Check power input CN800 Pin1 - Pin2

OK (DC12V)

Make sure that the operation command (ON signal) is transferring from the controller to the DX-Kit controller.
If the ON singal was OK, Replace the Relay PCB.

NG

Make sure that the operation command (ON signal) is transferring from the Controller to the DX-Kit controller.
If the ON singal was OK, Replace the Main PCB.

Other tips

Check Field function setting, (External input signal setting)
The Prohibit setting condtions
The operating mode mismatch

Trouble shooting 112

Peripheral device No Cooling / No Heating

Forecast of Cause :

1. Temperature controlling 2. EEV controlling 3. External Factor

General check procedure

1. Check Error code on the VRF system. (Remote controller, Service tool, etc)
2. Check LED brinks on the controler PCB of DX-KIT
3. Check Error code on the peripheral device.
4. Check none of protection function is operating on the system.
Protection functions (For the description of protective conditions, see the service manual.)
 - Abnormal Temperature: Compressor temperature, Discharge temperature, Heat-sink temperature, IDU HEX temp.
 - Abnormal pressure: High pressure, Low pressure,
 - Abnormal on devices: EEV coil, FAN motor, Compressor Frq,

Check Point 1: Temperature sensors

Sensor position / Wire connection / Temperature detection

- Measure the resistance of sensor at the terminal board, and compare the temperature (transformed with resistance value) with the actual detecting temperature by using the Service tool.

Gas / Liquid Sensor Characteristics (Rough value)

Temperature (°F)	32	41	50	59	68	77	86	95	104	113	122
Temperature (°C)	0	5	10	15	20	25	30	35	40	45	50
Resistance Value (kOhm)	33.6	25.2	20.1	15.8	12.5	10.0	8.0	6.5	5.3	4.3	3.5

Inlet / Outlet Air Sensor Characteristics (Rough value)

Temperature (°F)	32	41	50	59	68	77	86	95	104	113	122
Temperature (°C)	0	5	10	15	20	25	30	35	40	45	50
Resistance Value (kOhm)	168.6	129.8	100.9	79.1	62.5	49.8	40.0	32.4	26.3	21.2	17.8

- If the sensor position was incorrect, install the sensor to the correct position
- If the temperature detection was wrong, replace the sensor.

Check Point 2: EEV

Wire connection / EEV movment

- Measure the resistance of EEV coil and measure the DC12V power input at the terminal board.
EEV1: CN10_Pin No.1-Pin No.6, Pin No.1-Pin No.4, Pin No.2-Pin No.3, Pin No.2-Pin No.5)
EEV2: CN11_Pin No.1-Pin No.6, Pin No.1-Pin No.4, Pin No.2-Pin No.3, Pin No.2-Pin No.5)
- Check EEV initialisation movment by the power reset of DX-Kit.
- Check refrigerant flowing by measuring the temperature of pipe inlet and pipe outlet.

Read wire	Resistance value (20 °C)
White - Red	200 ± 10% Ω
Yellow - Brown	
Orange - Red	
Blue - Brown	

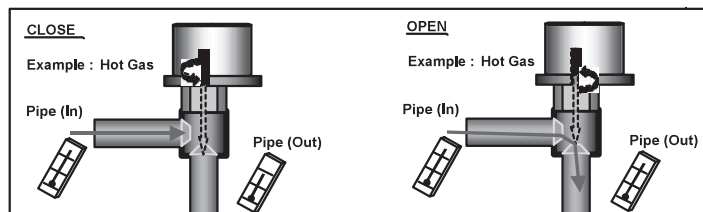

- If the resistance of EEV coil was not correct, replace the EEV unit.
- If the DC12V did not appear on the terminal, check DCV power supply on CN102.
No Voltage: Replace the power supply PCB, DC12V appears: Replace the controller PCB.
- If the EEV did not react after power reset, or no refrigerant flowing, replace the EEV unit.

Check Point 3: External factor

Air circulation obstruction
Design mismatch (Capacity, FAN speed mismatch, Field setting (Analog signal input) etc.)
Peripheral device abnormal (See the Service manual for the peripheral device)

Trouble shooting 113

DX-KIT Controller No Power
(LED on the Main PCB is OFF)

Forecast of Cause :

1. Power supply failuer
2. DX-Kit Electrical componert defective

Check Point 1 : Power supply

□ Is not the breaker down?

Instant drop ----- Check if there is a large load electric apparatus in the same circuit.

Momentary power failure ----- Check if there is a defective contact or leak current in the power supply circuit.

Noise ----- Check if there is any equipment causing harmonic wave near electric line (Neon bulb or electric equipment that may cause harmonic wave).

Check the complete insulation of grounding.

OK

Check Point 2: FUSE F101 on the Power supply PCB

OPEN

Before replacing the burnt FUSE,
make sure that the terminal between
L-N -E are not short-circuit.

OK

Check Point 2: Output voltage on the power supply PCB

Disconnect the CN 102 on the Power supply PCB.

Check voltage CN102 output voltage

Pin No.1 - Pin No.6: DC12V

Pin No.2 - Pin No.6: DC5V

NG

Replace the Power supply PCB

OK

the condition of short-circuit, and

Check Point 2: Output voltage on the main PCB

Disconnect the CN 801, and the power input connectors
for actuators (EEV, Sensor, Relay PCB.)

Check voltage CN801 output voltage

Pin No.1 - Pin No.2: DC12V

NG

Replace the Main PCB

OK

Check Point 2: Output voltage on the main PCB

Disconnect the power input connectors for actuators
(EEV, Sensor, Relay PCB.)

And check the short circuit of each actuators.

NG

Replace the actuators which has the
Short-circuit conditions

4-5 SERVICE PARTS INFORMATION

SERVICE PARTS INFORMATION 1

Compressor

Diagnosis method of Compressor (If Outdoor Unit 7 segment LED displays Error, refer to Trouble shooting)

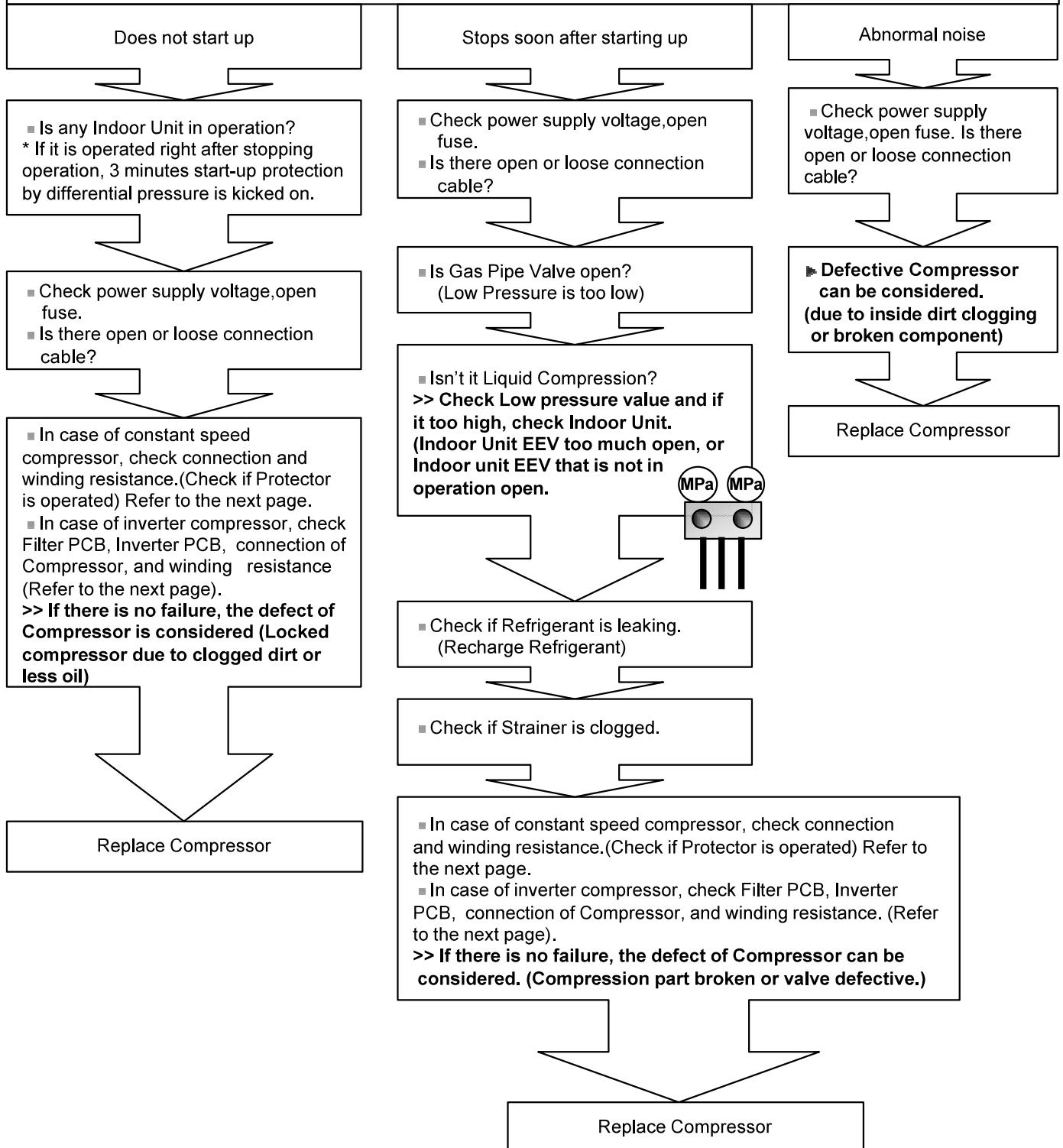

SERVICE PARTS INFORMATION 2

Inverter Compressor

Check Point 1 : Check Connection

❑ Check terminal connection of Compressor (loose or incorrect wiring)

❑ Check connection of Inverter PCB (Loose or incorrect wiring)

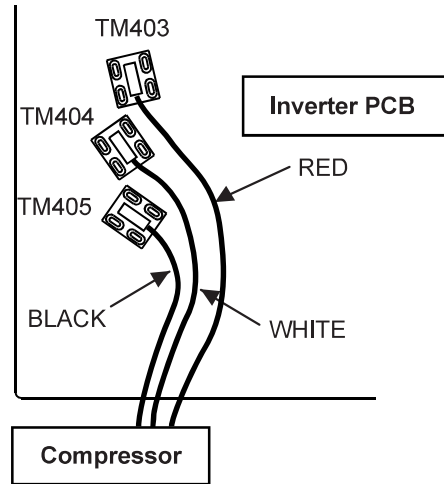
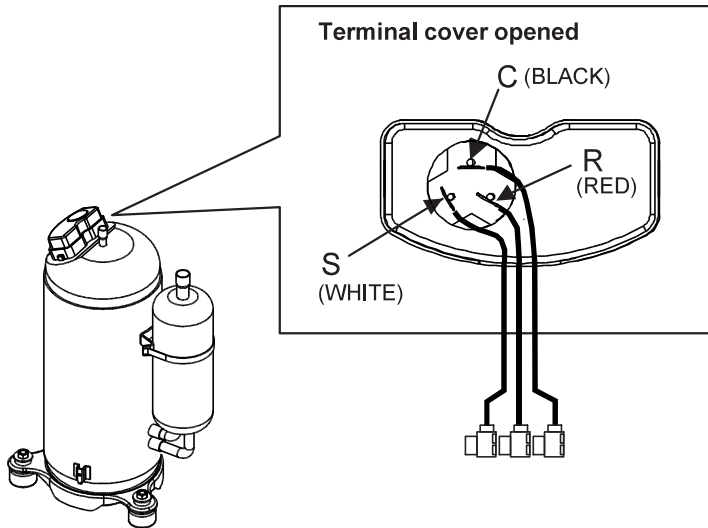

Check Point 2 : Check Winding Resistance

❑ Check winding resistance of each terminal

▶ **If the resistance value is 0Ω or infinite, replace Compressor.**

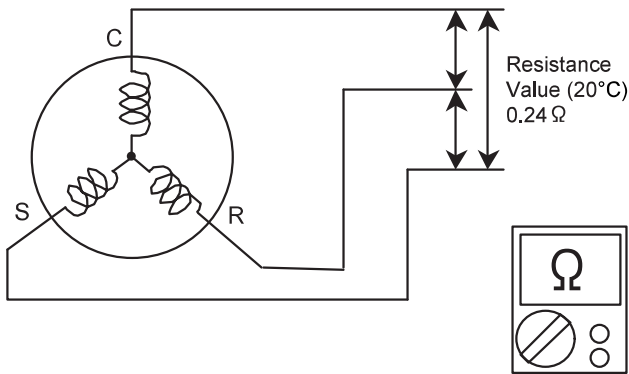

Attention!!

If Check 1, 2 are normal, make sure the following points.

(1) Check AC voltage among each terminals from filter PCB(INV) to Diode Bridge.
(Rated voltage among L and N).

▶ **If it does not appear, check the power supply terminal.**

(2) Check Voltage from Main PCB to Inverter PCB.
(DC13.5 - 16.5V between terminals of CN126 (1-2) connector
and DC (-12.0) - (-8.0)V between terminals of CN126 (3-2) connector of Main PCB).

▶ **If it does not appear, replace Main PCB.**

◆ **If both of above voltages appear, it is considered to be Inverter PCB circuit failure.
Replace Inverter PCB and check operation.**



SERVICE PARTS INFORMATION 3

Main PCB
Filter PCB

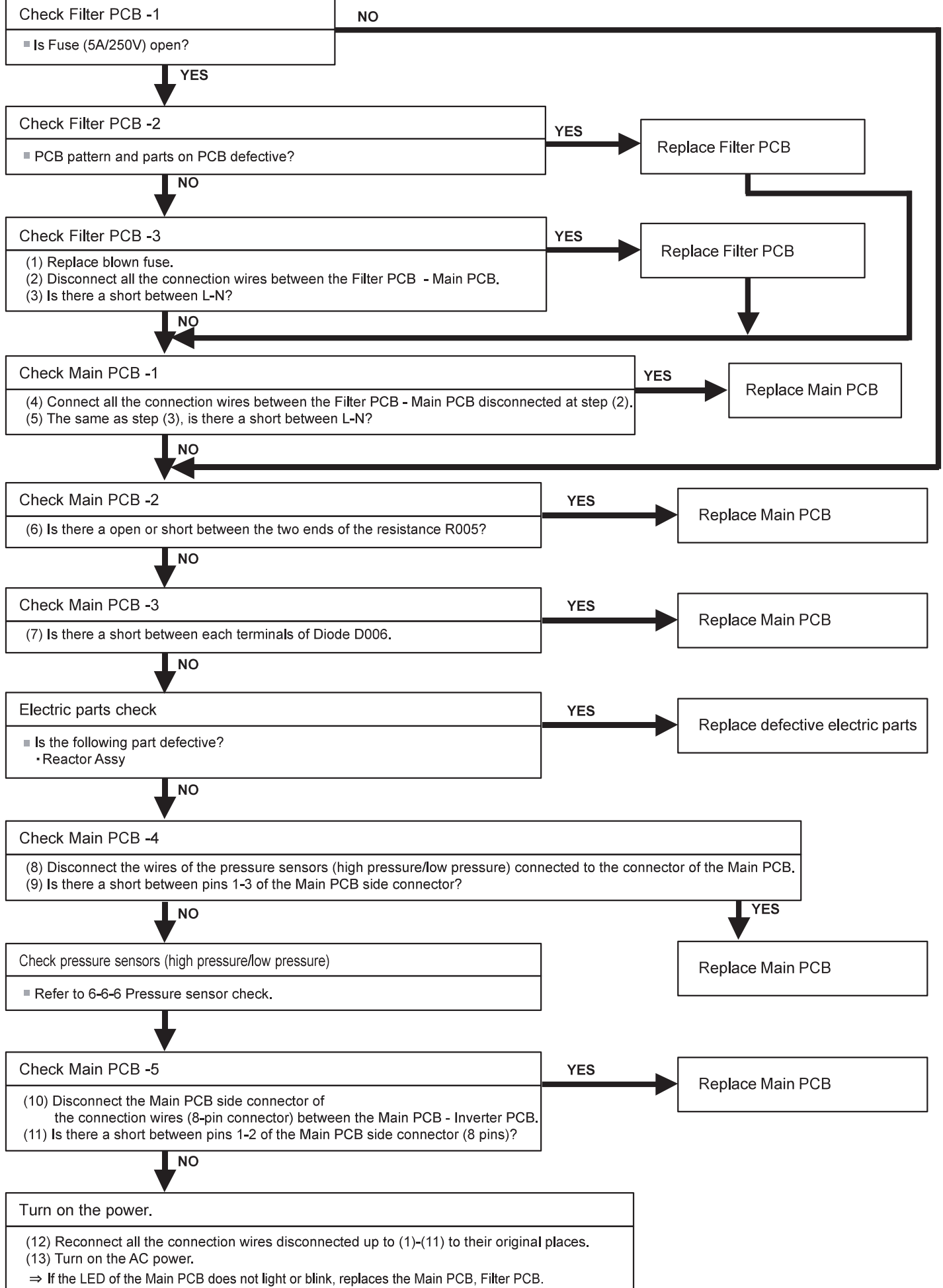

SERVICE PARTS INFORMATION 4

Inverter PCB Filter PCB

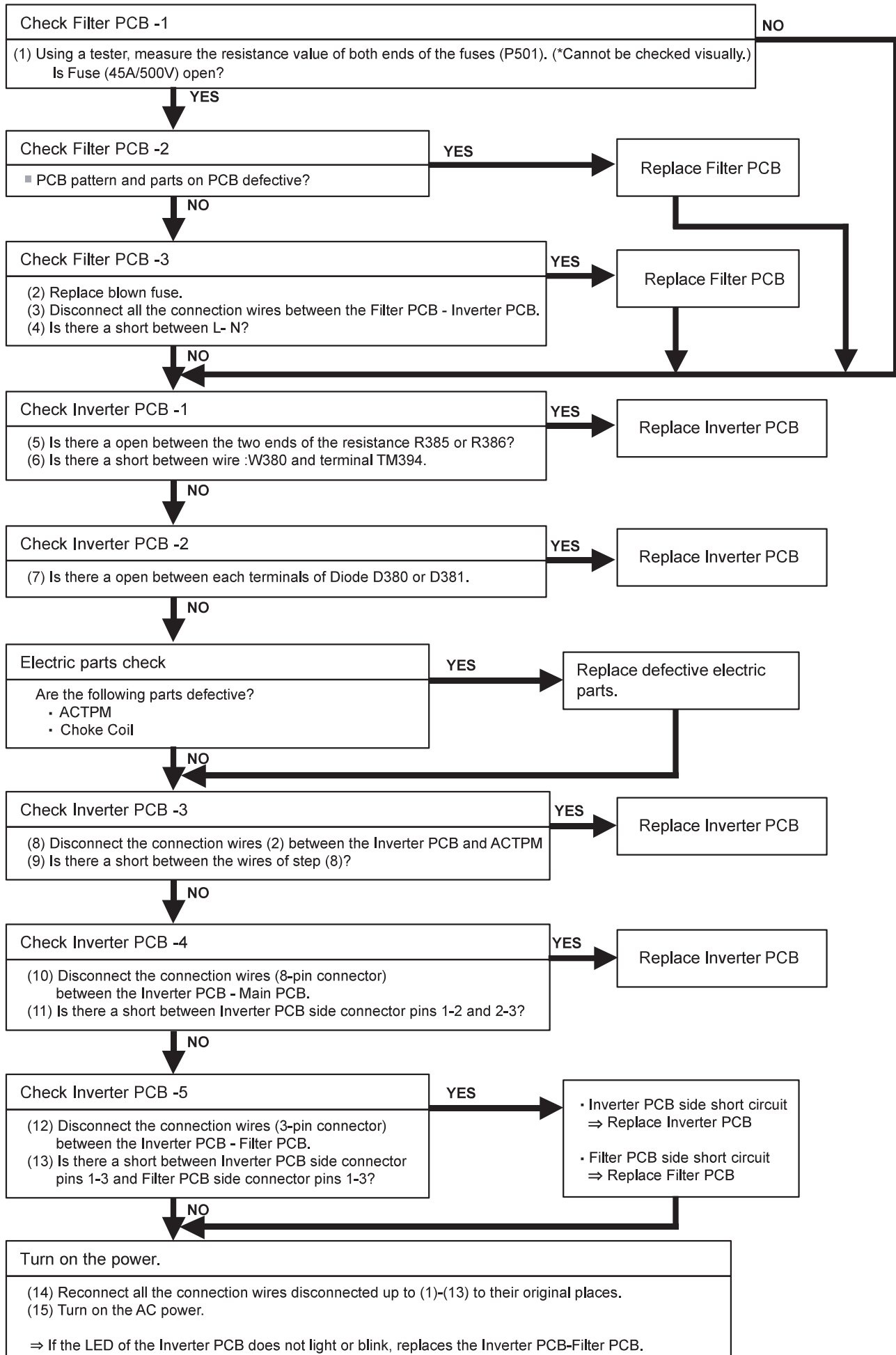

SERVICE PARTS INFORMATION 5

IPM
(Mounted on Inverter PCB)

Check Point 1

① Disconnect the connection wires between the Inverter PCB - ACTPM and Inverter PCB - Inverter Compressor.

② Set the tester to the "Resistance" mode, and measure the resistance between the following terminals.

Yellow wire (P) - Fasten terminals U/V/W
Blue wire (N) - Fasten terminals U/V/W

③ Judge the result of ② as follows:

All 6 points several MΩ or greater	: Normal
1 or more points several kΩ to short	: Defective

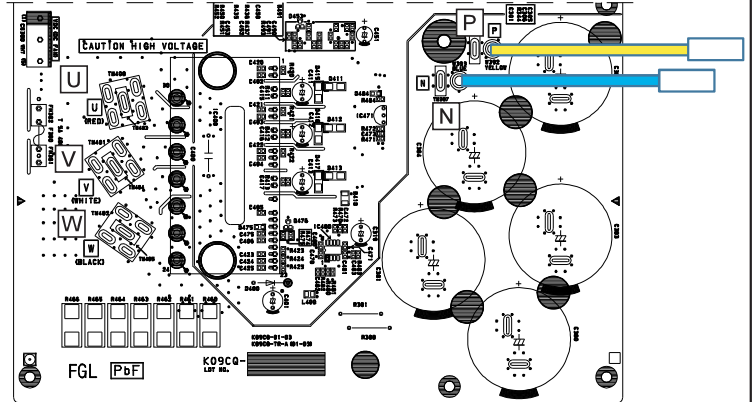

Inverter PCB

Check Point 2

④ Set the tester to the "Diode" mode, and measure the voltage value between the following terminals.

Tester +side (red)	Tester - side (black)	Tester display [V]
Terminal U	Yellow wire (P)	
Terminal V		
Terminal W		
Blue wire (N)	Terminal U	
	Terminal V	
	Terminal W	

⑤ Judge the result of ④ as follows:

All 6 points several 0.3V to 0.7V	: Normal
1 or more points under 0.1V or over load	: Defective

SERVICE PARTS INFORMATION 6

Choke Coil (INV)
Reactor assy (DC Fan)

Check Point 1 : Appearance check

□ No fissures, breaks, damage, etc. at the body and winding section, terminals section?

Check Point 2 : Electric check

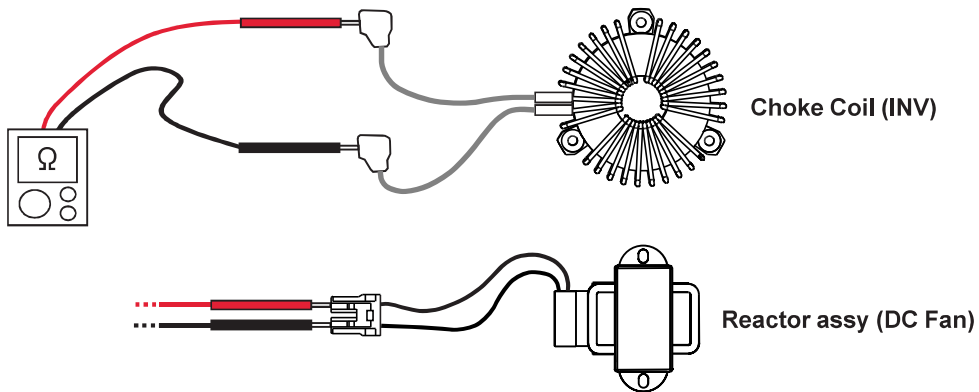

- ① Set the tester to the "Resistance" mode, and check for open/short between both ends of the reactor wire (or connector).
- ② Judge the result of ① as follows:

Short	: Normal
Open	: Abnormal (open)

SERVICE PARTS INFORMATION 7

Terminal

Check Point 1 : Appearance check

- No fissures, breaks, damage, etc. at the body and terminals section?
- Not clogged with foreign matter?
- Are there no abnormalities at threaded parts (Stripped threads, deformation, damage, etc.) ?

Check Point 2 : Electric check

- No short between adjacent terminals?
- Conducts before and after same terminal?



SERVICE PARTS INFORMATION 8

Indoor Unit Electronic Expansion Valve (EEV)

Check Point 1 : Check Connections

- Check Connectors (Loose connector or open cable.)

Duct

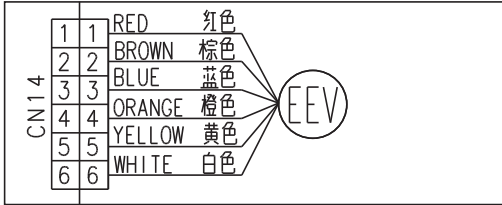

Small Wall mount

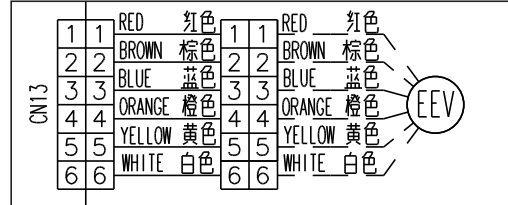

Floor/ Ceiling, Ceiling

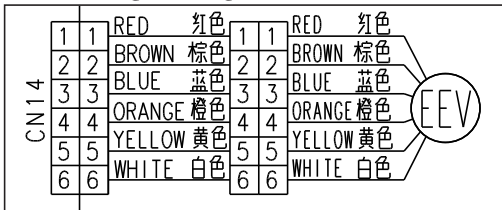

Cassette

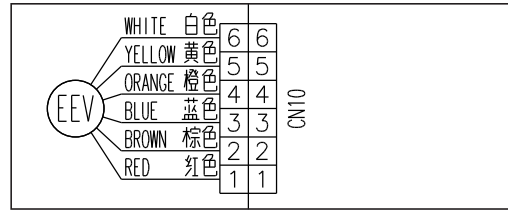

Wall mount

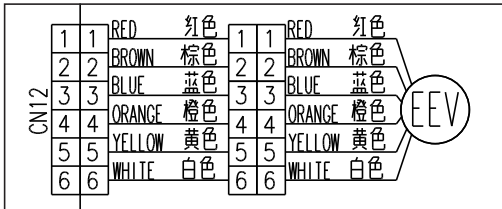

Check Point 2 : Check Coil of EEV

- Remove connector, check each winding resistance of Coil.

Read wire	Resistance value (20°C)
White - Red	200 ± 10% Ω
Yellow - Brown	
Orange - Red	
Blue - Brown	

- ▶ **If Resistance value is abnormal, replace EEV.**



Check Point 3 : Check Voltage from Controller PCB

- Remove Connector and check Voltage (DC12V).
 >> **If it does not appear, replace Controller PCB.**



Check Point 4 : Check Noise at start up

- Turn on Power and check operation noise.
 >> **If an abnormal noise does not show, replace Controller PCB.**

Check Point 5 : Check Opening and Closing Operation of Valve

When Valve is closed,
it has a temp. difference between Inlet and Outlet.

If it is open, it has no temp. difference between Inlet and Outlet.

CLOSE

Example : Hot GUS
Pipe (In)

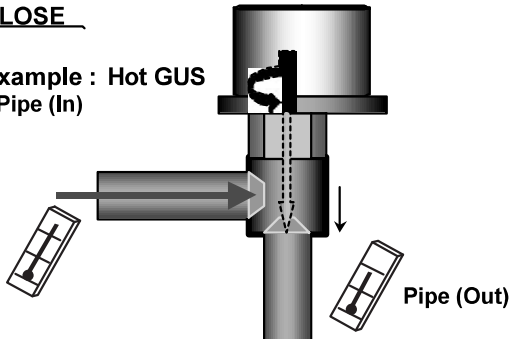

OPEN

Example : Hot GUS
Pipe (In)

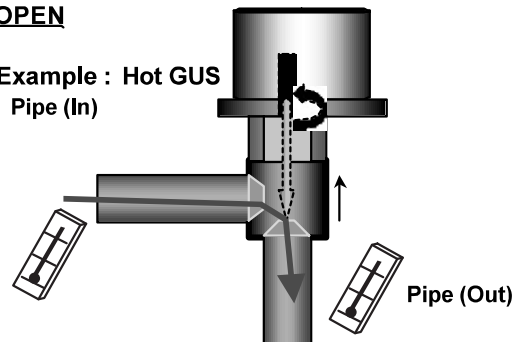

Check Point 6 : Check Strainer

Strainer normally does not have temperature difference between inlet and outlet as shown in (1), but if there is a difference as shown in (2), there is a possibility of inside clogged. In this case, replace Strainer.

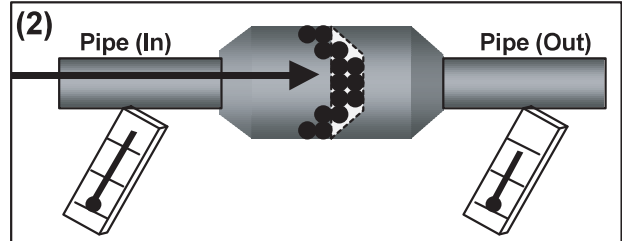
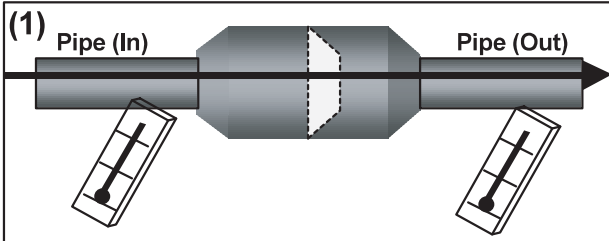

SERVICE PARTS INFORMATION 9

Outdoor Unit Electronic Expansion Valve (EEV1)

Check Point 1 : Check Connections

- Check connection of connector (CN116)
(Loose connector or open cable)

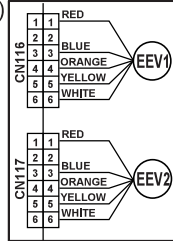

Check Point 2 : Check Coil of EEV1

- Remove connector, check each winding resistance of Coil.

Read wire	Resistance value (20°C)
White - Red	$46 \pm 4 \Omega$
Yellow - Red	
Orange - Red	
Blue - Red	

► **If Resistance value is abnormal, replace EEV.**

Check Point 3 : Check Voltage from Controller PCB

- Remove Connector and check Voltage (DC12V).
>> If it does not appear, replace Controller PCB.



Check Point 4 : Check Noise at start up

- Turn on Power and check operation noise.
>> If an abnormal noise does not show, replace Controller PCB.

Check Point 5 : Check Opening and Closing Operation of Valve

When Valve is closed,
it has a temp. difference between Inlet and Outlet.

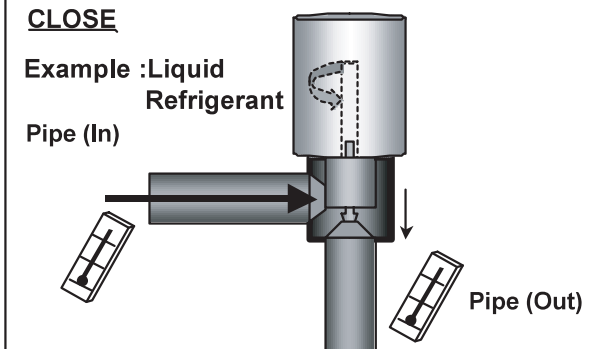

If it is open, it has no temp. difference between Inlet and Outlet.

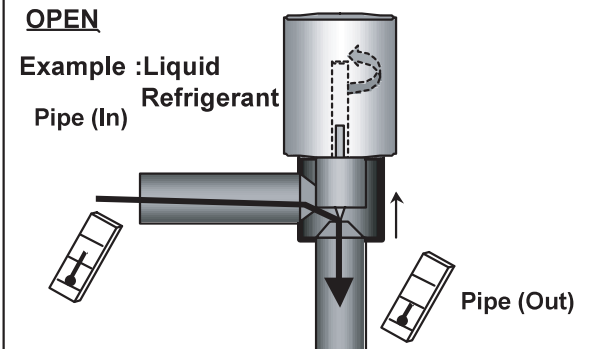

Check Point 6 : Check Strainer

Strainer normally does not have temperature difference between inlet and outlet as shown in (1), but if there is a difference as shown in (2), there is a possibility of inside clogged. In this case, replace Strainer.

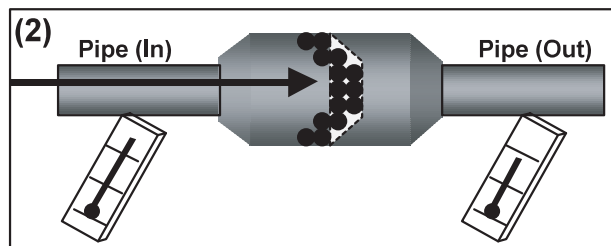
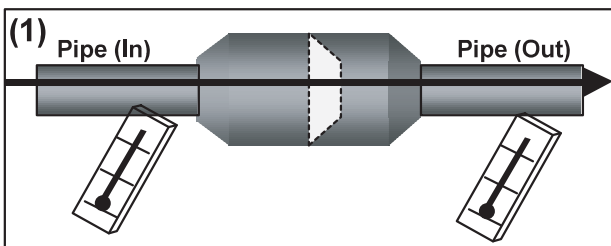

SERVICE PARTS INFORMATION 10

Outdoor Unit Electronic Expansion Valve (EEV2)

Check Point 1 : Check Connections

- Check connection of connector (CN117)
(Loose connector or open cable)

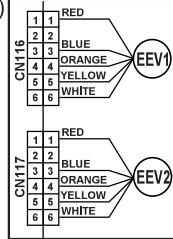

Check Point 2 : Check Coil of EEV2

- Remove connector, check each winding resistance of Coil.

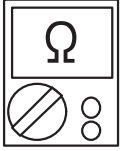
Read wire	Resistance value (20°C)
White - Red	$46 \pm 4 \Omega$ 
Yellow - Red	
Orange - Red	
Blue - Red	

► **If Resistance value is abnormal, replace EEV.**

Check Point 3 : Check Voltage from Controller PCB

- Remove Connector and check Voltage (DC12V).
-> **If it does not appear, replace Controller PCB.**



Check Point 4 : Check Noise at start up

- Turn on Power and check operation noise.
-> **If an abnormal noise does not show, replace Controller PCB.**

Check Point 5 : Check Opening and Closing Operation of Valve

When Valve is closed,
it has a temp. difference between Inlet and Outlet.

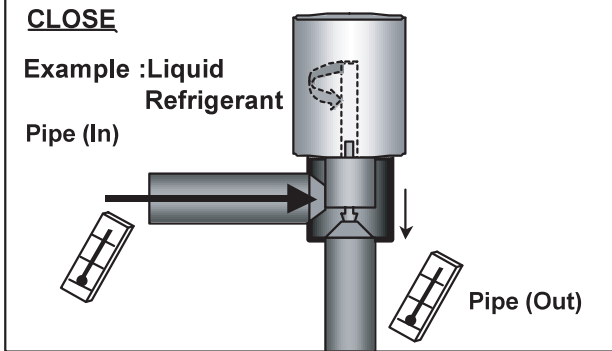

If it is open, it has no temp. difference between Inlet and Outlet.

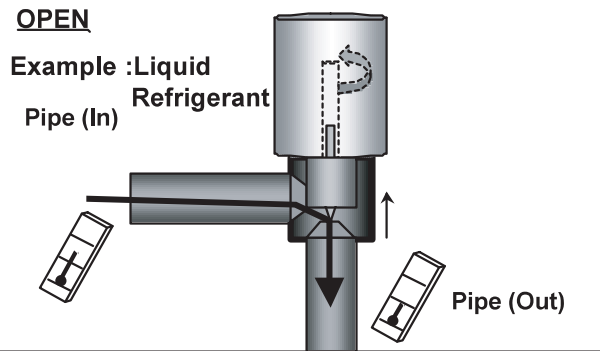

Check Point 6 : Check Strainer

Strainer normally does not have temperature difference between inlet and outlet as shown in (1), but if there is a difference as shown in (2), there is a possibility of inside clogged. In this case, replace Strainer.

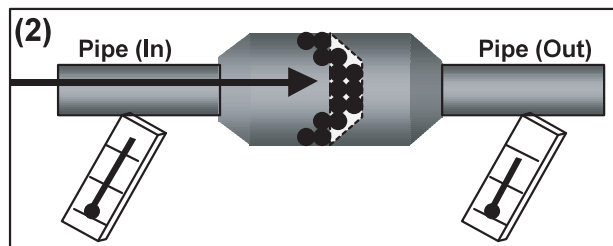
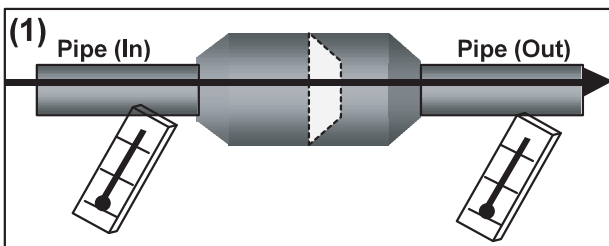

SERVICE PARTS INFORMATION 11

Outdoor Unit Solenoid Valve (SV2)

Check Point 1 : Check connections

- Check connection of connector. (Loose connector or open cable)

- AJ*A36, 45, 54LALH
>> CN107

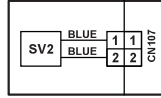

Check Point 2 : Check Solenoid Coil

- Remove connector and check if coil is open. (Normal resistance value of each coil: $1495 \pm 7\% \Omega$)

>> **If Resistance value is abnormal, replace Solenoid Coil.**

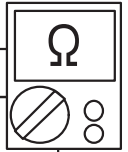

Check Point 3 : Check Voltage from Controller PCB

- Remove connector and check the voltage (Rated AC voltage).

>> **If the voltage does not appear, replace Controller PCB.**



Check Point 4 : Check opening & closing operation of Valve

- Depending on either during operation or protection control, check if Valve is operating normally. (When Valve opens, there is no temperature difference between Inlet and Outlet.)

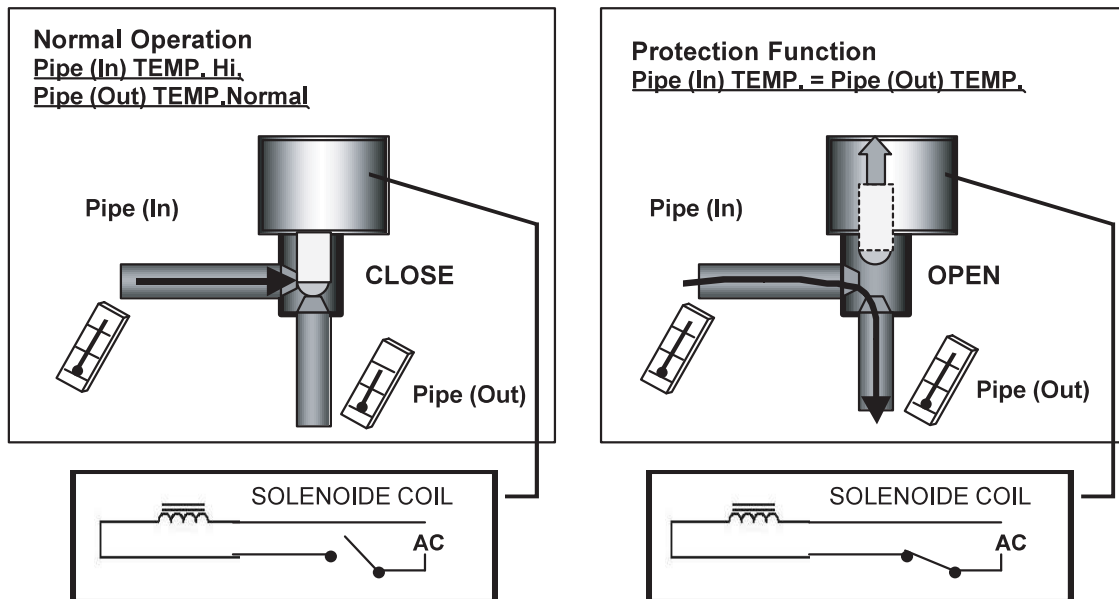

- If the valve closes by removing the connector of the valve which does not close, it is considered to be Controller PCB failure. Replace Controller PCB.

- If it does not close by removing connector, there is a possibility of (1) clogging by dirt, or (2) deformation by the heat at the time of Solenoid Valve installation. In this case, replace Solenoid Valve.

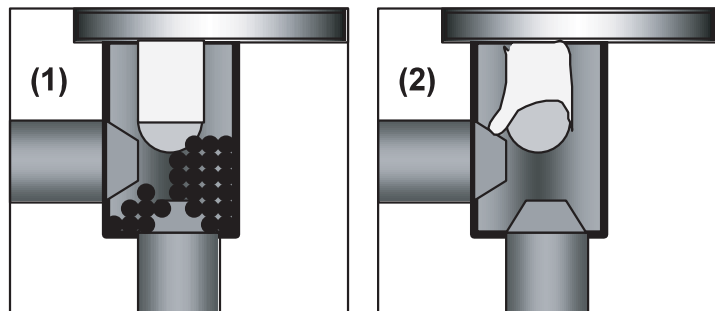

SERVICE PARTS INFORMATION 12

4-WAY VALVE

Check Point 1 : Check Circuit connection

- Check the connection of connector CN 105

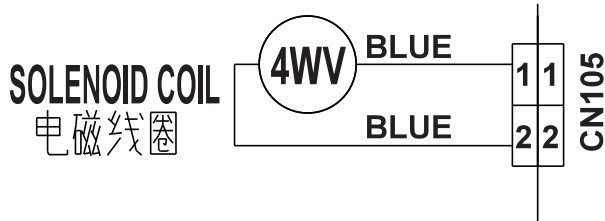

Check Point 2 : Check Solenoid Coil

- Remove CN6 from PCB and check the resistance value of coil

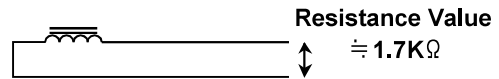

- ☆ If it is Open or abnormal resistance value, replace Solenoid Coil

Check Point 3: Check Operation of 4 Way Valve

- Check each piping temperature, and confirm the location of the valve by the temperature difference.

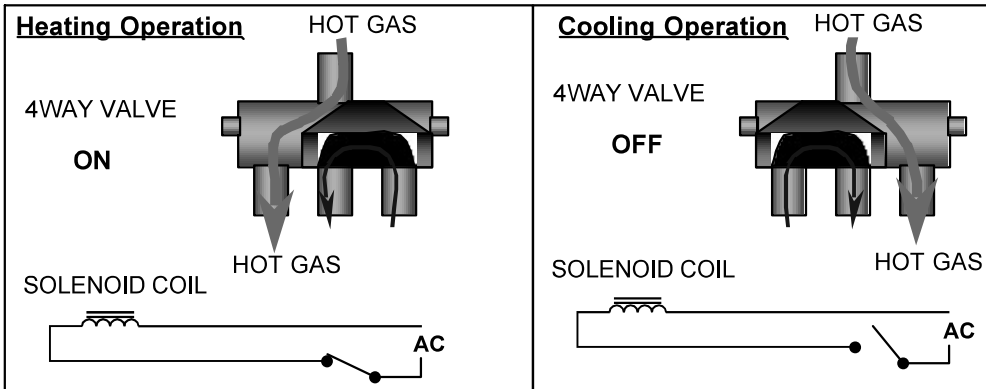

- ☆ If the valve location is not proper, replace 4 way valve.

Check Point 4: Check Voltage from Controller PCB

- Remove connector and check the voltage (Rated AC voltage).
>> **If the voltage does not appear, replace Controller PCB.**

SERVICE PARTS INFORMATION 13-1

Indoor Unit Fan Motor <AC motor>

- ARXB07/09/12/14/18LALH
- ARXB24/30/36/45LATH
- ARXA24/30/36/45LATH
- ARXC36/45LATH

Check Point : ARXB24LATH (Low Static pressure Duct Type)

□ Check each winding resistance of the motor

▶ **If Resistance value is abnormal, replace motor.**

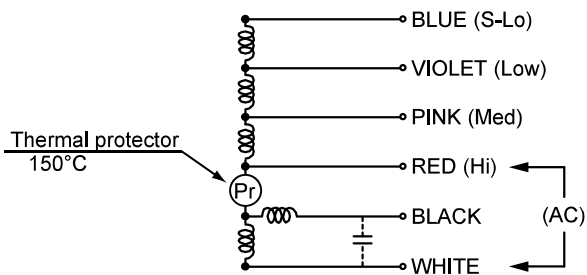

Lead wire	Resistance value
White – Red	44.8 Ω \pm 8%
Red – Black	37.3 Ω \pm 8%
Red – Pink	21.3 Ω \pm 8%
Pink – Violet	12.9 Ω \pm 8%
Violet – Blue	12.9 Ω \pm 8%

at 20°C

Check Point : ARXB30/ 36LATH (Low Static pressure Duct Type)

□ Check each winding resistance of the motor

▶ **If Resistance value is abnormal, replace motor.**

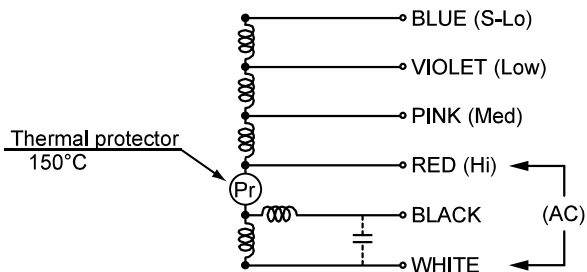

Lead wire	Resistance value
White – Red	47.1 Ω \pm 8%
Red – Black	27.4 Ω \pm 8%
Red – Pink	8.00 Ω \pm 8%
Pink – Violet	8.00 Ω \pm 8%
Violet – Blue	8.00 Ω \pm 8%

at 20°C

Check Point : ARXB45LATH (Low Static pressure Duct Type)

□ Check each winding resistance of the motor

▶ **If Resistance value is abnormal, replace motor.**

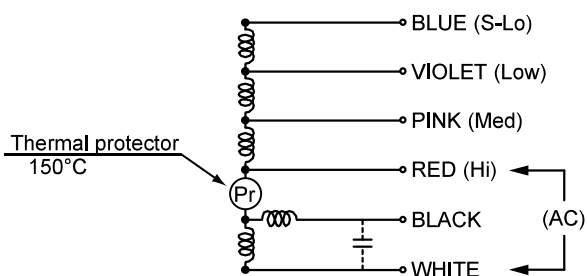

Lead wire	Resistance value
White – Red	19.7 Ω \pm 8%
Red – Black	13.0 Ω \pm 8%
Red – Pink	5.86 Ω \pm 8%
Pink – Violet	5.86 Ω \pm 8%
Violet – Blue	5.86 Ω \pm 8%

at 20°C

Check Point : ARXA24/ 30LATH (Duct Type)

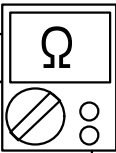

- Check each winding resistance of the motor
- ▶ **If Resistance value is abnormal, replace motor.**

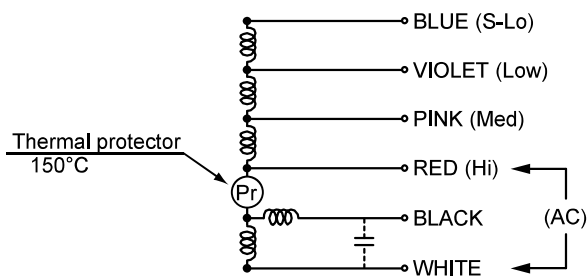

Lead wire	Resistance value
White – Red	47.1 Ω ± 8%
Red – Black	27.4 Ω ± 8%
Red – Pink	8.00 Ω ± 8%
Pink –Violet	8.00 Ω ± 8%
Violet – Blue	8.00 Ω ± 8%

at 20°C

Check Point : ARXA36/ 45LATH (Duct Type)

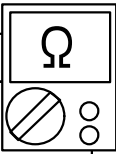

- Check each winding resistance of the motor
- ▶ **If Resistance value is abnormal, replace motor.**

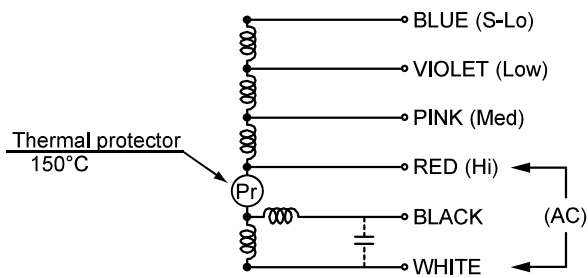

Lead wire	Resistance value
White – Red	19.7 Ω ± 8%
Red – Black	13.0 Ω ± 8%
Red – Pink	5.86 Ω ± 8%
Pink –Violet	5.86 Ω ± 8%
Violet – Blue	5.86 Ω ± 8%

at 20°C

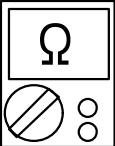

Check Point : ARXB07LALH (Compact Duct Type)

- ❑ Check each winding resistance of the motor
- ▶ **If Resistance value is abnormal, replace motor.**

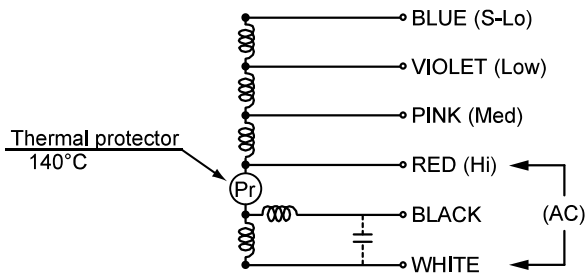

Lead wire	Resistance value
White – Red	579 Ω ± 8%
Red – Black	255 Ω ± 8%
Red – Pink	162 Ω ± 8%
Pink – Violet	66 Ω ± 8%
Violet – Blue	93 Ω ± 8%

at 20°C

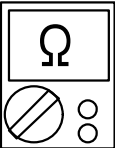

Check Point : ARXB09LALH (Compact Duct Type)

- ❑ Check each winding resistance of the motor
- ▶ **If Resistance value is abnormal, replace motor.**

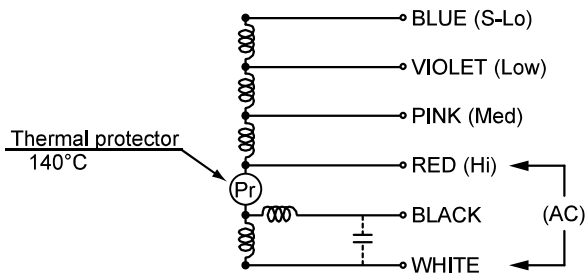

Lead wire	Resistance value
White – Red	322.8 Ω ± 8%
Red – Black	255 Ω ± 8%
Red – Pink	103 Ω ± 8%
Pink – Violet	53 Ω ± 8%
Violet – Blue	100.7 Ω ± 8%

at 20°C

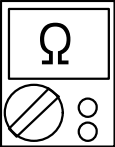

Check Point : ARXB12LALH (Compact Duct Type)

- ❑ Check each winding resistance of the motor
- ▶ **If Resistance value is abnormal, replace motor.**

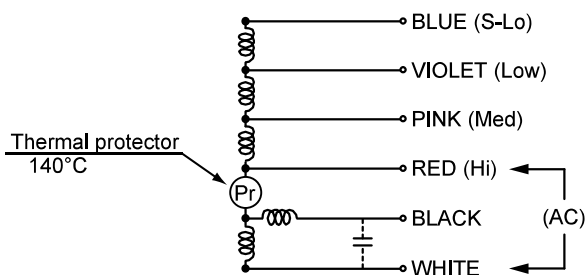

Lead wire	Resistance value
White – Red	336 Ω ± 8%
Red – Black	261 Ω ± 8%
Red – Pink	107 Ω ± 8%
Pink – Violet	55 Ω ± 8%
Violet – Blue	103 Ω ± 8%

at 20°C

Check Point : ARXB14LALH (Compact Duct Type)

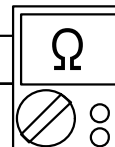

- Check each winding resistance of the motor
- ▶ **If Resistance value is abnormal, replace motor.**

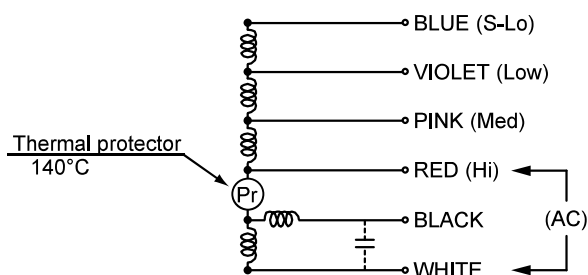

Lead wire	Resistance value
White – Red	136.5 Ω \pm 8%
Red – Black	125.6 Ω \pm 8%
Red – Pink	23.7 Ω \pm 8%
Pink – Violet	23.7 Ω \pm 8%
Violet – Blue	49.4 Ω \pm 8%

at 20°C

Check Point : ARXB18LALH (Compact Duct Type)

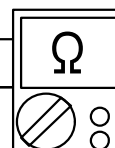

- Check each winding resistance of the motor
- ▶ **If Resistance value is abnormal, replace motor.**

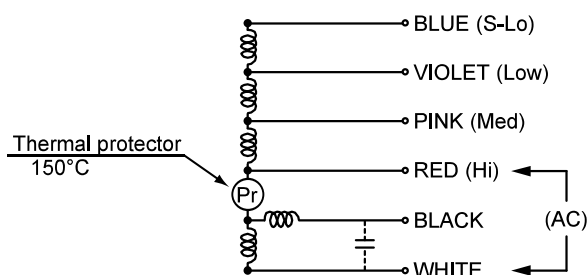

Lead wire	Resistance value
White – Red	89.7 Ω \pm 8%
Red – Black	150 Ω \pm 8%
Red – Pink	37.4 Ω \pm 8%
Pink – Violet	37.4 Ω \pm 8%
Violet – Blue	197 Ω \pm 8%

at 20°C

Check Point : ARXC36LATH (High Static Pressure Duct Type)

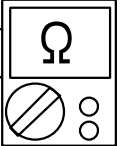

- Check each winding resistance of the motor
- ▶ **If Resistance value is abnormal, replace motor.**

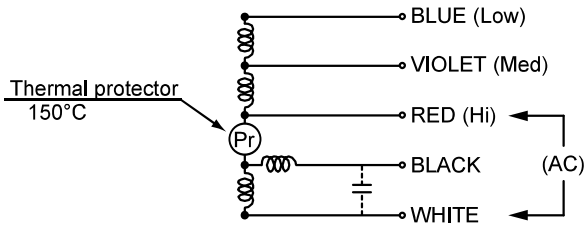

Lead wire	Resistance value
White – Red	13.4 Ω ± 8%
Red – Black	16.9 Ω ± 8%
Red – Violet	11.5 Ω ± 8%
Violet – Blue	13.3 Ω ± 8%

at 20°C

Check Point : ARXC45LATH (High Static Pressure Duct Type)

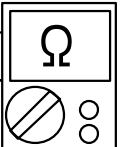

- Check each winding resistance of the motor
- ▶ **If Resistance value is abnormal, replace motor.**

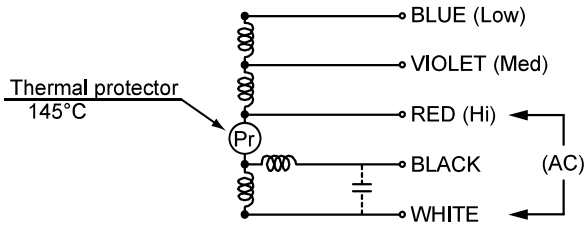

Lead wire	Resistance value
White – Red	6.84 Ω ± 7%
Red – Black	9.78 Ω ± 7%
Red – Violet	6.1 Ω ± 7%
Violet – Blue	6.1 Ω ± 7%

at 20°C

SERVICE PARTS INFORMATION 13-2

Indoor Unit Fan Motor <DC motor>

⚠ When you approach this part, please cut off the power supply and wait for a while until DC voltage has been discharged.

Check Point 1 : Check rotation of Fan

- Rotate the fan by hand when operation is off.
(Check if fan is caught, dropped off or locked motor)
- >>If Fan or Bearing is abnormal, replace it.**

Check Point 2 : Check resistance of Indoor Fan Motor

- Refer to below. Circuit-test "Vm" and "GND" terminal.
(Vm: DC voltage, GND: Earth terminal)

>>If they are short-circuited (below 300 k Ω), replace Indoor fan motor and Controller PCB.

Pin number (wire color)	Terminal function (symbol)
1 (Brown or Blue)	Feed back (FG)
2 (Yellow)	Speed command (Vsp)
3 (White)	Control voltage (Vcc)
4 (Black)	Earth terminal (GND)
5	No function
6 (Red)	DC voltage (Vm)

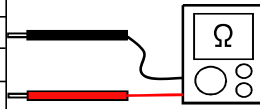

SERVICE PARTS INFORMATION 14

Discharge Pressure Sensor Suction Pressure Sensor

1. Discharge Pressure Sensor

Check Point : Check Voltage from Main PCB

- With the connector connected to the PCB, measure the voltage between CN118:2-3 of the Main PCB.

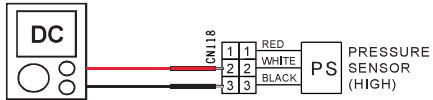

- Characteristics of pressure sensor

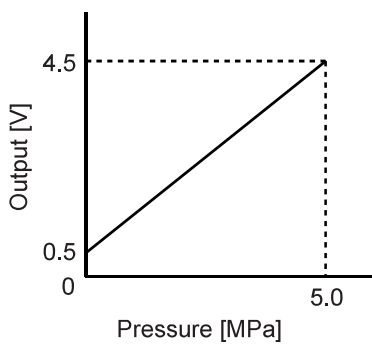

2. Suction Pressure Sensor

Check Point : Check Voltage from Main PCB

- With the connector connected to the PCB, measure the voltage between CN119:2-3 of the Main PCB.

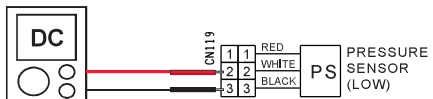

- Characteristics of pressure sensor

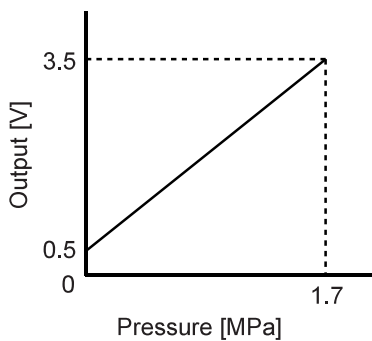

SERVICE PARTS INFORMATION 15

Pressure switch

• Type of contact

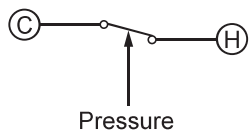

• Characteristics of pressure switch

	Pressure switch (For Inverter comp.)
Contact : Short ⇒ Open	4.2±0.1MPa
Contact : Open ⇒ Short	3.2±0.15MPa

SERVICE PARTS INFORMATION 16

Thermistor

Check Point : Check Thermistor resistance value

- Remove connector and check Thermistor resistance value.

Temperature [°C]	Resistance Value [kΩ]		
	Thermistor A	Thermistor B	Thermistor C
- 20	---	---	105.4
- 10	---	27.8	58.2
- 5	---	21.0	44.0
0	168.6	16.1	33.6
5	129.8	12.4	25.9
10	100.9	9.6	20.2
15	79.1	7.6	15.8
20	62.6	6.0	12.5
25	49.8	4.8	10.0
30	40.0	3.8	8.0
40	26.3	2.5	5.3
50	17.8	1.7	3.6
60	12.3	1.2	---
70	8.7	---	---
80	6.3	---	---
90	4.6	---	---
100	3.4	---	---
110	2.6	---	---
120	2.0	---	---
Applicable Thermistors	Discharge temp. TH : [TH1] Comp temp. TH : [TH10]	Heat exchanger. TH : [TH5] Suction temp. TH : [TH4] Sub-cool heat exchanger (inlet) TH : [TH8] Sub-cool heat exchanger (outlet) TH : [TH9] Liquid temp. TH : [TH7]	Outdoor temp. TH : [TH3]

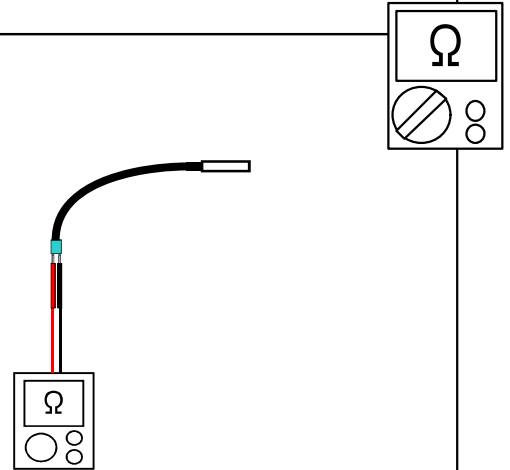

SERVICE PARTS INFORMATION 17

ACTPM (Active Filter Module)

Check Point 1 : Appearance check

- No fissures, breaks, damage, etc. at the body and terminals section?

Check Point 2 : Electric check

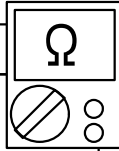

- ① Disconnect the connection wires.
- ② Set the tester to the "Resistance" mode, and measure the resistance between the following terminals.
 (+IN) - (-IN)
 L1 - L2
 P - N
- ③ Judge the result of ② as follows:

All 3 points several MΩ or greater	: Normal
1 or more points several kΩ to short	: Defective

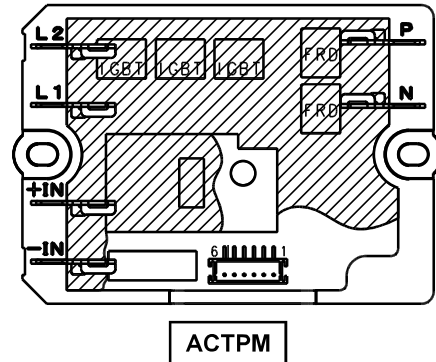

Check Point 3

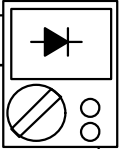

- ④ Set the tester to the "Diode" mode, and measure the voltage value between the following terminals.

Tester +side (red)	Tester - side (black)	Tester display [V]
L2	P	

- ⑤ Judge the result of ④ as follows:

Several 0.3V to 0.7V	: Normal
Under 0.1V or over load	: Defective

SERVICE PARTS INFORMATION 18

Outdoor Unit Fan Motor

⚠ When you approach this part, please cut off the power supply and wait for a while until DC voltage has been discharged.

Check Point 1 : Check rotation of Fan

- Rotate the fan by hand when operation is off.
(Check if fan is caught, dropped off or locked motor)
- >>If Fan or Bearing is abnormal, replace it.**

Check Point 2 : Check resistance of Outdoor Fan Motor

- Refer to below. Circuit-test "Vm" and "GND" terminal.
(Vm: DC voltage, GND: Earth terminal)
- >>If they are short-circuited (below 300 k Ω), replace Outdoor fan motor.**

Pin number (wire color)	Terminal function (symbol)
1 (Red)	DC voltage (Vm)
2	No function
3	No function
4 (Black)	Earth terminal (GND)
5 (White)	Control voltage (Vcc)
6 (Yellow)	Speed command (Vsp)
7 (Brown)	Feed back (FG)

