

HITACHI

HHAW

NO. 0076E-5

SERVICE MANUAL TECHNICAL INFORMATION

FOR SERVICE PERSONNEL ONLY

OUTDOOR UNIT

INDOOR UNIT

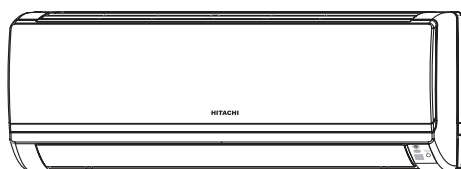
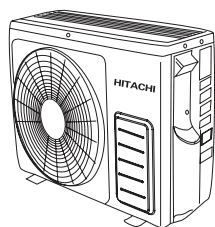

RAC-18WEB
RAC-25WEB
RAC-35WEB

RAK-18PEB
RAK-25PEB/RAK-25PEBC
RAK-35PEB/RAK-35PEBC
RAK-50PEB/RAK-50PEBC

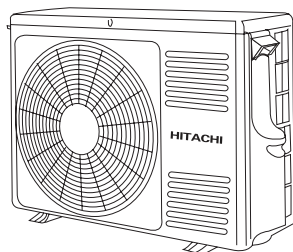

RAC-50WEB



RAK-18PEB/RAC-18WEB
RAK-25PEB/RAC-25WEB
RAK-35PEB/RAC-35WEB
RAK-50PEB/RAC-50WEB
RAK-25PEBC/RAC-25WEB
RAK-35PEBC/RAC-35WEB
RAK-50PEBC/RAC-50WEB

REFER TO THE FOUNDATION MANUAL CONTENTS

SPECIFICATIONS	6
HOW TO USE	9
CONSTRUCTION AND DIMENSIONAL DIAGRAM	17
MAIN PARTS COMPONENT	20
WIRING DIAGRAM	22
CIRCUIT DIAGRAM	24
BLOCK DIAGRAM	27
BASIC MODE	28
REFRIGERATING CYCLE DIAGRAM	38
PROCEDURE FOR DISASSEMBLY AND REASSEMBLY.....	40
DESCRIPTION OF MAIN CIRCUIT OPERATION	43
SERVICE CALL Q & A	68
TROUBLE SHOOTING	72
PARTS LIST AND DIAGRAM	104

SPECIFICATIONS

TYPE	DC INVERTER								
	INDOOR UNIT		OUTDOOR UNIT		INDOOR UNIT		OUTDOOR UNIT		
MODEL	RAK-18PEB	RAC-18WEB	RAK-25PEB RAK-25PEBC	RAC-25WEB	RAK-35PEB RAK-35PEBC	RAC-35WEB	RAK-50PEB RAK-50PEBC	RAC-50WEB	
POWER SOURCE	1 PHASE,50HZ,220-230V		1 PHASE,50HZ,220-230V		1 PHASE,50HZ,220-230V		1 PHASE,50HZ,220-230V		
COOLING	TOTAL INPUT (W)	580 (250 ~ 1,010)		700 (250~1,290)		1,090 (250~1,460)		1,560 (500~2,100)	
	TOTAL AMPERES (A)	3.00-2.97		3.87-3.70		5.57-5.33		7.29-6.85	
	CAPACITY (KW)	2.00 (0.90~2.50)		2.50 (0.90~3.10)		3.50 (0.90~4.00)		5.00 (1.90~5.20)	
	(B.T.U./h)	6,820 (3,070~8,530)		8,530 (3,070~10,580)		11,940 (3,070~13,650)		17,060 (6,480~17,740)	
HEATING	TOTAL INPUT (W)	620 (250~970)		880 (250~1,250)		1,100 (250~1,700)		1,660 (500~2,750)	
	TOTAL AMPERES (A)	3.52-3.37		4.65-4.44		5.63-5.39		7.56-7.23	
	CAPACITY (KW)	2.50 (0.90~3.20)		3.40 (0.90~4.40)		4.20 (0.90~5.00)		6.00 (2.20~7.30)	
	(B.T.U./h)	8,530 (3,070~10,920)		11,600 (3,070~15,010)		14,330 (3,070~17,060)		20,470 (7,510~24,910)	
DIMENSIONS (mm)	W	780	660(+60)*	780	660(+60)*	780	660(+60)*	780	792(+91)*
	H	280	530	280	530	280	530	280	600
	D	218	278(+35)*	218	278(+35)*	218	278(+35)*	218	299(+47)*
NET WEIGHT (Kg)	7.5	27.5	7.5	27.5	7.5	27.5	8	40	

* After installation

SPECIFICATIONS AND PARTS ARE SUBJECT TO CHANGE FOR IMPROVEMENT

ROOM AIR CONDITIONER

INDOOR UNIT + OUTDOOR UNIT

Hitachi Household Appliances(Wuhu) Co., Ltd.

SAFETY DURING REPAIR WORK

1. In order to disassemble and repair the unit in question, be sure to disconnect the power cord plug from the power outlet before starting the work.

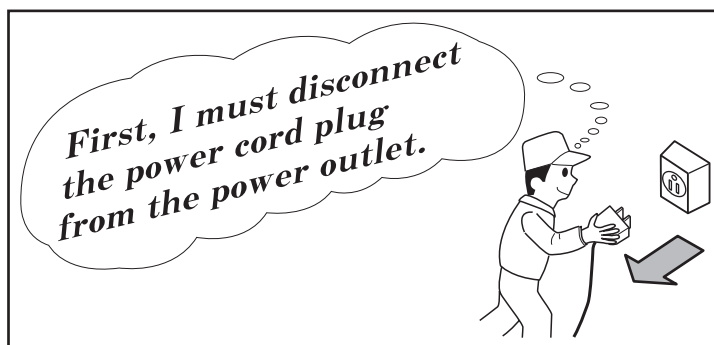

2. If it is necessary to replace any parts, they should be replaced with respective genuine parts for the unit, and the replacement must be effected in correct manner according to the instructions in the Service Manual of the unit.

If the contacts of electrical parts are defective, replace the electrical parts without trying to repair them

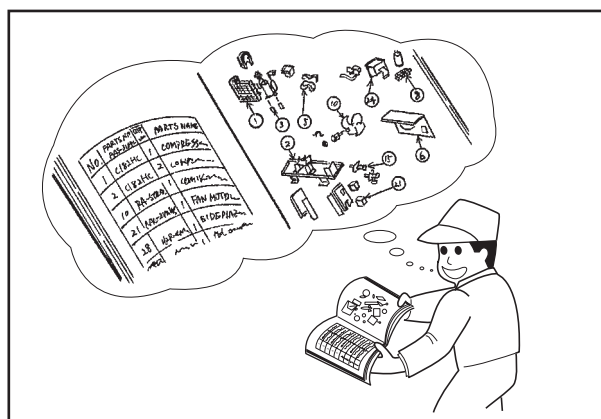

3. After completion of repairs, the initial state should be restored.
4. Lead wires should be connected and laid as in the initial state.
5. Modification of the unit by the user himself should absolutely be prohibited.
6. Tools and measuring instruments for use in repairs or inspection should be accurately calibrated in advance.
7. In installing the unit having been repaired, be careful to prevent the occurrence of any accident such as electrical shock, leak of current, or bodily injury due to the drop of any part.
8. To check the insulation of the unit, measure the insulation resistance between the power cord plug and grounding terminal of the unit.
The insulation resistance should be $1M\Omega$ or more as measured by a 500V DC megger.
9. The initial location of installation such as window, floor or the other should be checked for being safe enough to support the repaired unit again.
If it is found not so strong and safe, the unit should be installed at the initial location after reinforced or at a new location.
10. Any inflammable object must not be placed about the location of installation.
11. Check the grounding to see whether it is proper or not, and if it is found improper, connect the grounding terminal to the earth.



WORKING STANDARDS FOR PREVENTING BREAKAGE OF SEMICONDUCTORS

1. Scope

The standards provide for items to be generally observed in carrying and handling semiconductors in relative manufactures during maintenance and handling thereof. (They apply the same to handling of abnormal goods such as rejected goods being returned.)

2. Object parts

- (1) Microcomputer
- (2) Integrated circuits (I.C.)
- (3) Field effective transistor (F.E.T.)
- (4) P.C. boards or the like to which the parts mentioned in (1) and (2) of this paragraph are equipped.

3. Items to be observed in handling

- (1) Use a conductive container for carrying and storing of parts. (Even rejected goods should be handled in the same way.)

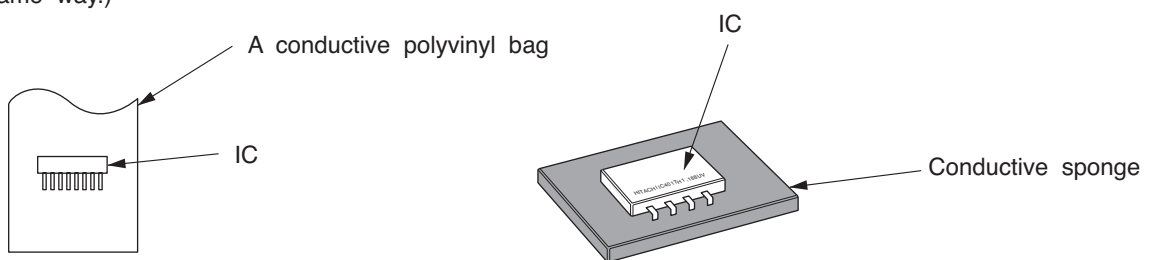

Fig. 1 Conductive container

- (2) When any part is handled uncovered (in counting, packing and the like), the handling person must always use himself as a body earth. (Make yourself a body earth by passing one M ohm earth resistance through a ring or bracelet.)
- (3) Be careful not to touch the parts with your clothing when you hold a part even if a body earth is being taken.
- (4) Be sure to place a part on a metal plate with grounding.
- (5) Be careful not to fail to turn off power when you repair the printed circuit board. At the same time, try to repair the printed circuit board on a grounded metal plate.

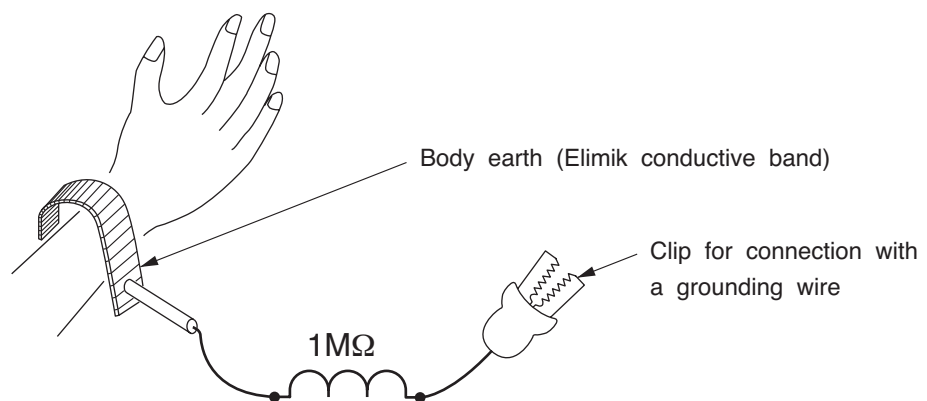

Fig. 2 Body earth

(6) Use a three wire type soldering iron including a grounding wire.

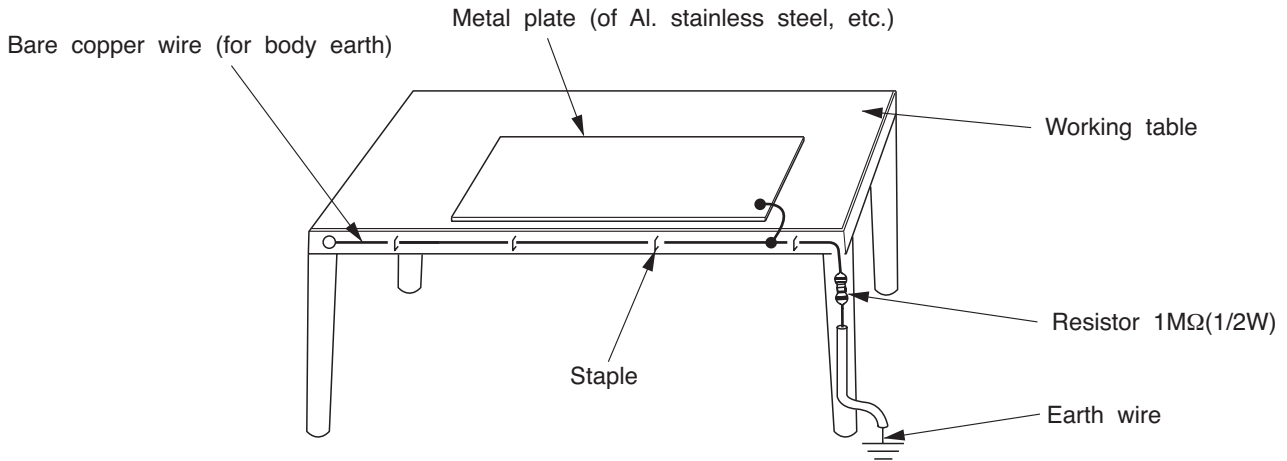

Fig.3 Grounding of the working table

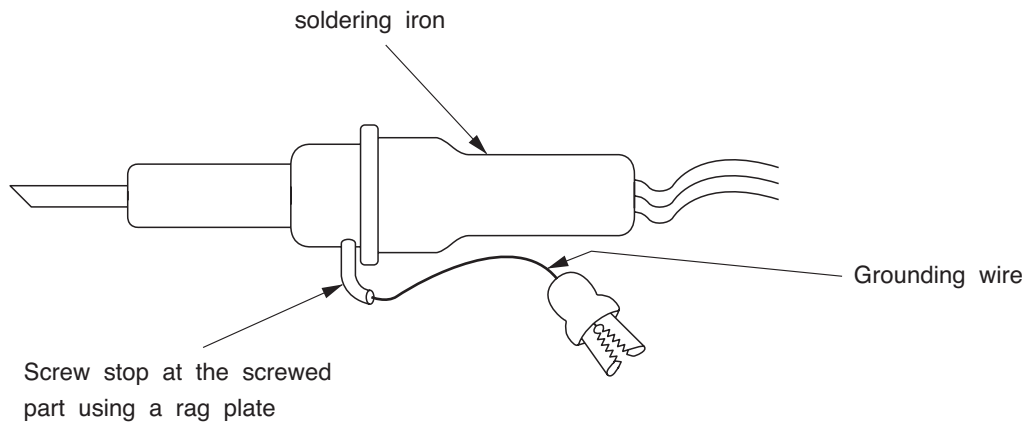

Fig.4 Grounding a solder iron

Use a high insulation mode (100V, 10MΩ or higher) when ordinary iron is to be used.

(7) In checking circuits for maintenance, inspection, or some others, be careful not to have the test probes of the measuring instrument short circuit a load circuit or the like.

 **CAUTION**

1. In quiet or stop operation, slight flowing noise of refrigerant in the refrigerating cycle is heard occasionally, but this noise is not abnormal for the operation.
2. When it thunders near by, it is recommend to stop the operation and turn off the circuit breaker for safety.
3. In the event of power failure, the room air conditioner will restart automatically in the previously selected mode once the power is restored. In the event of power failure during TIMER operation, the room air conditioner will not start automatically. Re-press ON/OFF button after 3 minutes from when the unit off or power recovery.
4. If the room air conditioner is stopped by adjusting thermostat, or missoperation, and re-start in a moment, there is occasion that the cooling and heating operation does not start for 3 minutes, it is not abnormal and this is the result of the operation of IC delay circuit. This IC delay circuit ensures that there is no danger of blowing fuse or damaging parts even if operation is restarted accidentally.
5. This room air conditioner should not be used at the cooling operation when the outside temperature is below -10°C (14°F).
6. This room air conditioner (the reverse cycle) should not be used when the outside temperature is below -15°C (5°F).
If the reverse cycle is used under this condition, the outside heat exchanger is frosted and efficiency falls.
7. When the outside heat exchanger is frosted, the frost is melted by operating the hot gas system, it is not trouble that at this time fan stops and the vapour may rise from the outside heat exchanger.

SPECIFICATIONS

MODEL	RAK-18PEB RAK-25PEB/RAK-25PEBC RAK-35PEB/RAK-35PEBC RAK-50PEB/RAK-50PEBC	RAC-18WEB RAC-25WEB RAC-35WEB	RAC-50WEB
FAN MOTOR	30W (DC325V)	47W (DC120~380V)	
FAN MOTOR CAPACITOR	NO	NO	
FAN MOTOR PROTECTOR	NO	NO	
COMPRESSOR	-	ASD084SFNA7JK1	ASG133CDNB7AT
COMPRESSOR MOTOR CAPACITOR	NO	NO	
OVERLOAD PROTECTOR	NO	YES(INTERNAL)	
OVERHEAT PROTECTOR	NO	YES	
FUSE (for MICROPROCESSOR)	3.15A	15A, 2A, 3A, 3.15A	25A, 2A, 3A, 3.15A
POWER RELAY	NO	G4A-1A	
POWER SWITCH	NO	NO	
TEMPORARY SWITCH	YES	NO	
SERVICE SWITCH	NO	YES	
TRANSFORMER	YES	YES	
VARISTOR	450NR	450NR, ERZVA431	
NOISE SUPPRESSOR	NO	YES	
THERMOSTAT	YES(IC)	YES(IC)	
REMOTE CONTROL SWITCH (LIQUID CRYSTAL)	YES	NO	
REFRIGERANT CHARGING VOLUME (Refrigerant R410A)	UNIT	-----	950g 1250g
	PIPES (MAX. 20m) (MIN. 3m)	WITHOUT REFRIGERANT BECAUSE COUPLING IS FLARE TYPE.	

Figure showing the installation of Indoor and Outdoor unit

MODEL RAK-18PEB/RAC-18WEB
 RAK-25PEB/RAC-25WEB
 RAK-35PEB/RAC-35WEB
 RAK-25PEBC/RAC-25WEB
 RAK-35PEBC/RAC-35WEB

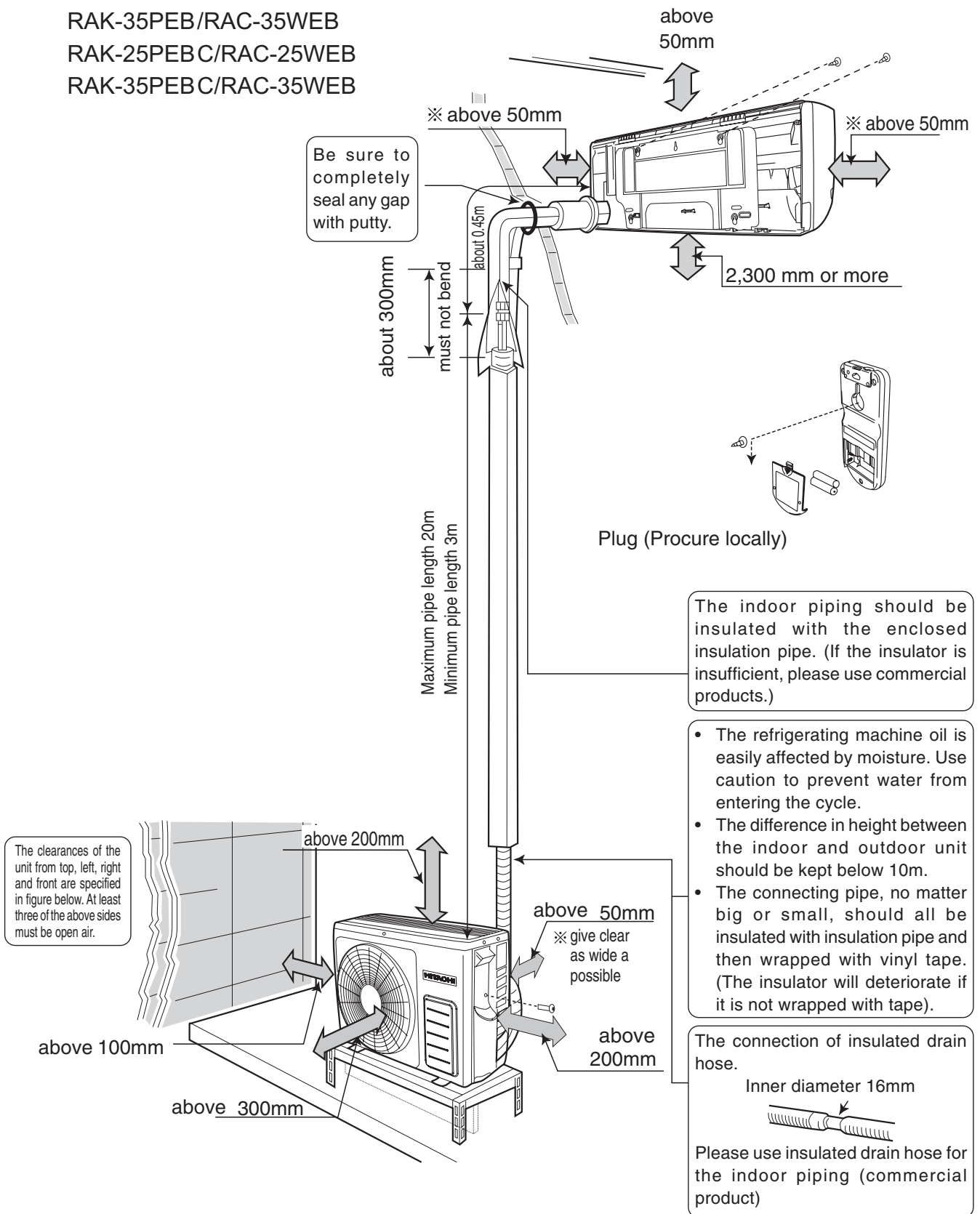
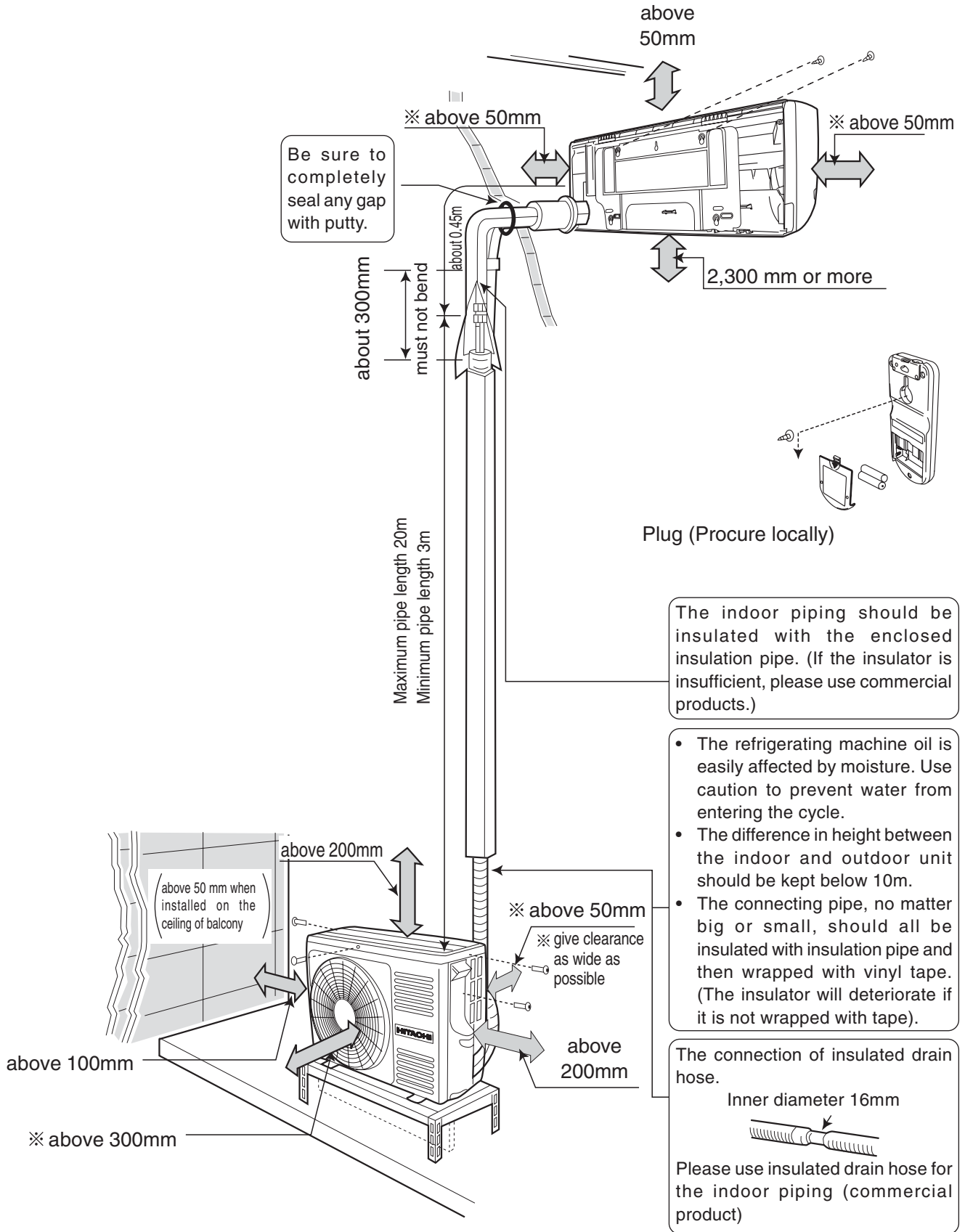

Figure showing the installation of Indoor and Outdoor unit

MODEL RAK-50PEB/RAC-50WEB
RAK-50PEBC/RAC-50WEB



NAMES AND FUNCTIONS OF REMOTE CONTROLLER

- This controls the operation function and timer setting of the room air conditioner. The range of control is about 7 meters. If indoor lighting is controlled electronically, the range of control may be shorter.

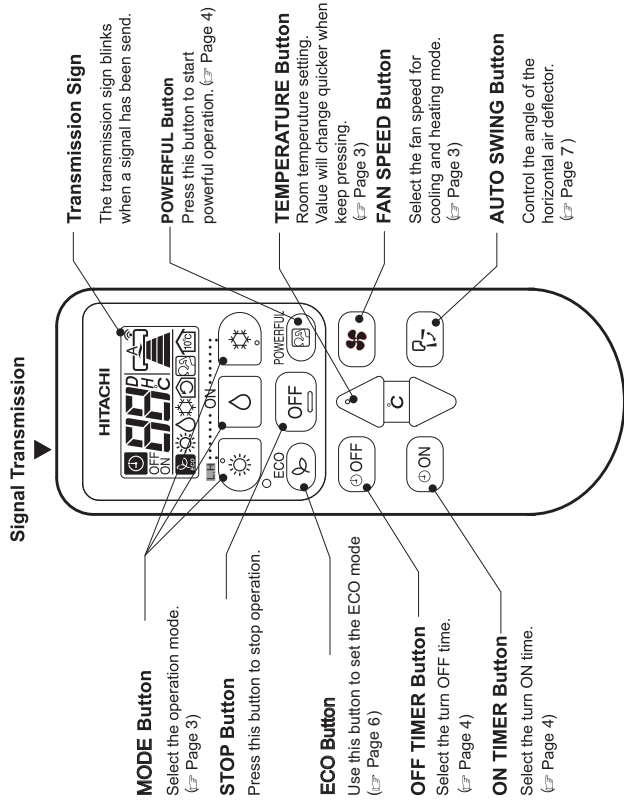

Precautions for Use

- Do not put the remote controller under direct sunlight and high temperature.
- Do not drop it on the floor, and protect it from water.
- If you press the FUNCTION button during operation, the air conditioner may stop for about 3 minutes for protection before you can start it again.

MANUAL OPERATION [Heating • Dehumidify • Cooling]

- Please use under below condition when you want to set the function mode, room temperature and fan speed manually.

HEATING	DEHUMIDIFYING	COOLING
Outdoor Temperature 24°C below	Room Temperature 16°C above	Outdoor Temperature 21°C above

1 OPERATION MODE SELECTION

- Every time you press the button, the mode will change as the below.



2 ROOM TEMPERATURE SETTING



- The cooling operation does not start if the temperature setting is higher than the current room temperature.

3 FAN SPEED SETTING

- Every time you press the button, fan speed will change as below sequence.



4 Press the OFF (STOP) button

- Operation stops with a beep.

TIMER RESERVATION

- ON Timer and OFF Timer are available.

Timer Reservation

1 OFF TIME setting

- Select the OFF TIME by pressing the (OFF) (OFF) Button.
- Setting time will change according to the below sequence when you press the button.

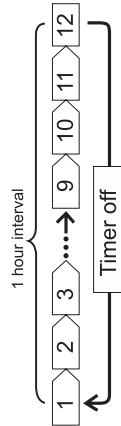

2 ON TIME setting

- Select the ON TIME by pressing the (ON) (ON) Button.
- Setting time will change according to the below sequence when you press the button.

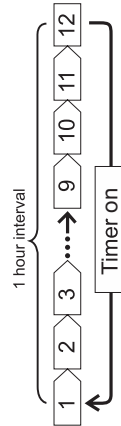

- Operation stop at setting time

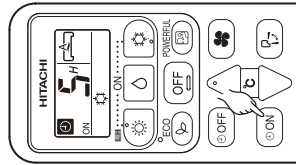
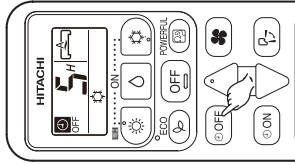

LEAVE HOME(LH) OPERATION

- Prevent the room temperature from falling too much by setting temperature at 10 deg automatically when no one is at home.

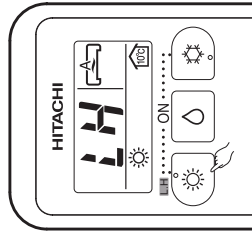

START

Hold down the HEATING Button for 3-5 seconds to start Leave Home operation.

- Room temperature is automatically set at 10 deg.
- "LH" is displayed on the LCD.

CANCEL

Press the (STOP) button. Change to other Operation Mode.

NOTE

- During Leave Home operation, fan speed and horizontal air deflector position cannot be changed.

POWERFUL OPERATION

- By pressing (POWERFUL) button during AUTO, HEATING, DEHUMIDIFYING, COOLING or FAN operation, the air conditioner performs at maximum power.
- During POWERFUL operation, cooler or warmer air will be blown out from indoor unit for COOLING or HEATING operation respectively.

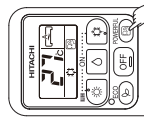

START

Press the (POWERFUL) button during operation.

- "POWERFUL" is displayed on the LCD.
- POWERFUL operation ends in 20 minutes. Then the system automatically operates with the previous settings used before POWERFUL operation.

CANCEL

Press the (POWERFUL) button again.

- "POWERFUL" disappears from the LCD.

NOTE

- When ECO mode, or LEAVE HOME mode is selected, POWERFUL operation is cancelled.
- During POWERFUL operation, capacity of the air conditioner will not increase
 - if the air conditioner is already running at maximum capacity.
 - just before defrost operation (when the air conditioner is running in HEATING operation).
- After auto restart, POWERFUL operation is cancelled and previous operation shall start.

ECO OPERATION

- Energy saving operation by changing set temperature and by limiting the maximum power consumption value.

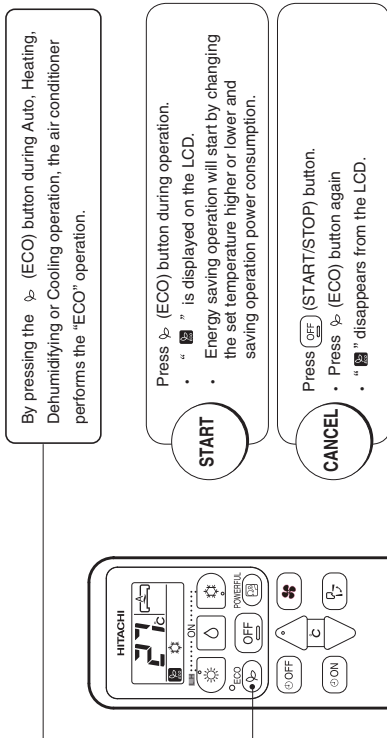

NOTE

- In case the power consumption is already low, ECO operation will not reduce the power consumption.
- By pressing (POWERFUL) button, ECO operation is cancelled.
- After auto restart, ECO operation is cancelled and previous operation mode shall start.

ADJUSTING THE AIRFLOW DIRECTION

- Adjust the airflow upward and downward. According to operation, the horizontal air deflector is automatically set to the proper angle suitable for each operation. The deflector can be swung up and down and also set to the desired angle using the " (AUTO SWING) " button.

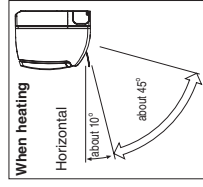
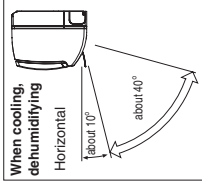

- If the " (AUTO SWING) " button is pressed once, the horizontal air deflector swings up and down. If the button is pressed again, the deflector stops in its current position. Several seconds (about 6 seconds) may be required before the deflector starts to move.
- The adjusting range of the horizontal air deflector is shown on the right.
- When the operation is stopped, the horizontal air deflector moves and stops at the position where the air outlet closes.

CAUTION

- In "Cooling" operation, do not keep the horizontal air deflector swinging for a long time. Some dew may form on the horizontal air deflector and some dew may drop from it.

2

- Adjust the airflow to left and right. Hold the vertical air deflector as shown on the right and adjust the airflow to left and right.



HOW TO EXCHANGE THE BATTERIES IN THE REMOTE CONTROLLER

- Remove the cover as shown in the figure and take out the old batteries.

Push and pull to the direction of arrow

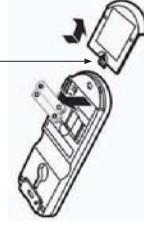



- Install the new batteries. The direction of the batteries should match the marks in the case.

CAUTION

- Do not use new and old batteries, or different kinds of batteries together.
- Take out the batteries when you do not use the remote controller for 2 or 3 months.



SAFETY PRECAUTION

- Please read the "Safety Precaution" carefully before operating the unit to ensure correct usage of the unit.
- Pay special attention to signs of "▲ Warning" and "▲ Caution". The "Warning" section contains matters which, if not observed strictly, may cause death or serious injury. The "Caution" section contains matters which may result in serious consequences if not observed properly. Please observe all instructions strictly to ensure safety.
- The signs indicate the following meanings. (The following are examples of signs.)

-  Make sure to connect earth line.
-  This sign in the figure indicates prohibition.
-  Indicates the instructions that must be followed.

Please keep this manual after reading.



PRECAUTIONS DURING INSTALLATION

▲ WARNING	<ul style="list-style-type: none"> • Do not reconstruct the unit. Water leakage, fault, short circuit or fire may occur if you reconstruct the unit by yourself. • Please ask your sales agent or qualified technician for the installation of your unit. Water leakage, short circuit or fire may occur if you install the unit by yourself. • Please use earth line. Do not place the earth line near water or gas pipes, lightning-conductor, or the earth line of telephone. Improper installation of earth line may cause electric shock or fire. • Be sure to use the specified piping set for R410A. Otherwise, this may result in broken copper pipes or faults. 	 PROHIBITION
	<ul style="list-style-type: none"> • A circuit breaker should be installed depending on the mounting site of the unit. Without a circuit breaker, the danger of electric shock exists. • Do not install the unit near a location where there is flammable gas. The outdoor unit may catch fire if flammable gas leaks around it. • Please ensure smooth flow of water when installing the drain hose. • Make sure that a single phase 220V-230V power source is used. The use of other power sources may cause electrical components to overheat and lead to fire. 	 CONNECT EARTH LINE
▲ CAUTION	<ul style="list-style-type: none"> • Do not place plants directly under the airflow as it is bad for the plants. • Be sure to stop the operation by using the remote controller and turn off the circuit breaker during cleaning, the high-speed fan inside the unit may cause danger. • Turn off the circuit breaker if the unit is not operated for a long period. 	 PROHIBITION



PRECAUTIONS DURING SHIFTING OR MAINTENANCE

▲ WARNING	<ul style="list-style-type: none"> • Should abnormal situation arise (like burning smell), please stop operating the unit and turn off the circuit breaker. Contact your agent. Fault, short circuit or fire may occur if you continue to operate the unit under abnormal situation. • Please contact your agent for maintenance. Improper self maintenance may cause electric shock and fire. • Please contact your agent if you need to remove and reinstall the unit. Electric shock or fire may occur if you remove and reinstall the unit yourself improperly. 	 PROHIBITION
--------------	--	--

PRECAUTIONS DURING OPERATION

▲ WARNING	<ul style="list-style-type: none"> • Avoid an extended period of direct airflow for your health. • Do not put objects like thin rods into the panel of blower and suction side because the high-speed fan inside may cause danger. • Do not use any conductor as fuse wire, this could cause fatal accident. • During thunder storm, disconnect the plug top and turn off the circuit breaker. • Spray cans and other combustibles should not be located within a meter of the air outlets of both indoor and outdoor units. As a spray can's internal pressure can be increased by hot air, a rupture may result. 	 PROHIBITION
	<ul style="list-style-type: none"> • Do not touch the refrigerant pipe and connecting valve. Burns may result. 	 DON'T TOUCH

PRECAUTIONS DURING OPERATION

▲ CAUTION	<ul style="list-style-type: none"> • The product shall be operated under the manufacturer specification and not for any other intended use. • Do not attempt to operate the unit with wet hands, this could cause fatal accident. • When operating the unit with burning equipments, regularly ventilate the room to avoid oxygen insufficiency. • Do not direct the cool air coming out from the air-conditioner panel to face household heating apparatus as this may affect the working of apparatus such as the electric kettle, oven etc. • Please ensure that outdoor mounting frame is always stable, firm and without defect. If not, the outdoor unit may collapse and cause danger. • Do not wash the unit with water or place a water container such as a vase on the indoor unit. Electrical leakage could be present and cause electric shock. • Do not place plants directly under the airflow as it is bad for the plants. • Be sure to stop the operation by using the remote controller and turn off the circuit breaker during cleaning, the high-speed fan inside the unit may cause danger. • Turn off the circuit breaker if the unit is not operated for a long period. • Do not climb on the outdoor unit or put objects on it. • When operating the unit with the door and windows opened, (the room humidity is always above 80%) and with the air deflector facing down or moving automatically for a long period of time, water will condense on the air deflector and drips down occasionally. This will wet your furniture. Therefore, do not operate under such condition for a long time. • If the amount of heat in the room is above the cooling or heating capability of the unit (for example: more people entering the room, using heating equipments and etc.), the preset room temperature cannot be achieved. • Indoor unit cleaning must be performed by authorized personnel only. Consult your sales agent. Using a commercially available detergent or similar can damage the plastic parts or clog the drain pipe, causing water to drip with potential electric shock hazard. • Do not touch the air outlet, bottom surface and aluminium fin of the outdoor unit. You may get hurt. • Do not touch the refrigerant pipe and connecting valve. Burns may result. • This appliance is not intended for use by young children or infirm persons unless they have been adequately supervised by a responsible person to ensure that they can use this appliance safely. • Young children should be supervised to ensure that they do not play with the appliance. 	 PROHIBITION
	<ul style="list-style-type: none"> • Do not touch the refrigerant pipe and connecting valve. Burns may result. 	 DON'T TOUCH

NAMES AND FUNCTIONS OF EACH PART

INDOOR UNIT

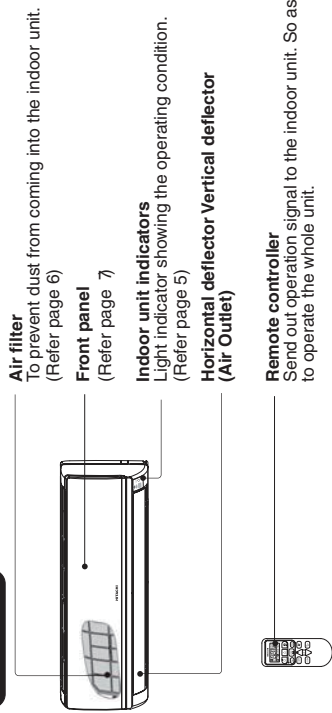

OUTDOOR UNIT

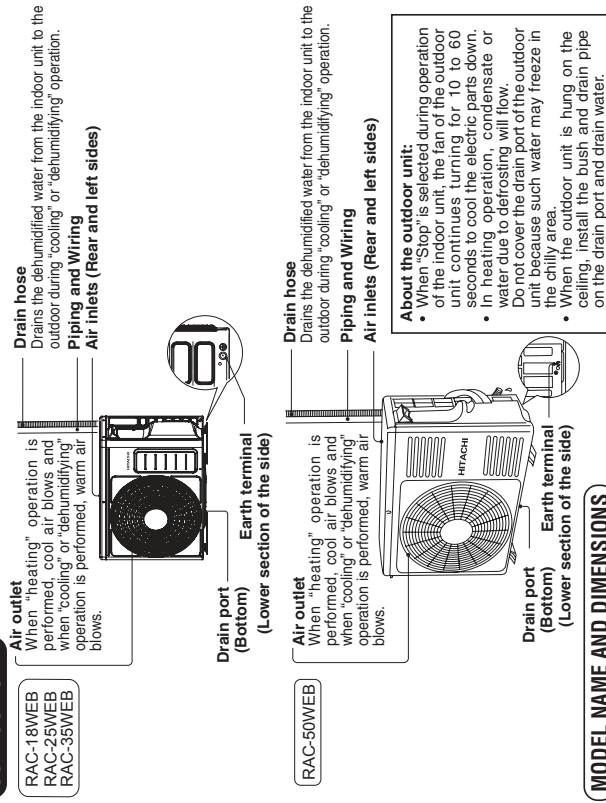

MODEL NAME AND DIMENSIONS

MODEL	WIDTH (mm)	HEIGHT (mm)	DEPTH (mm)
RAK-18PEB, RAK-25PEB, RAK-35PEB, RAK-50PEB	780	280	218
RAK-23PEBC, RAK-38PEBC, RAK-50PEBC	660	530	278
RAC-18WEB, RAC-25WEB, RAC-35WEB	792	600	299

NAMES AND FUNCTIONS OF EACH PART

INDOOR UNIT INDICATIONS

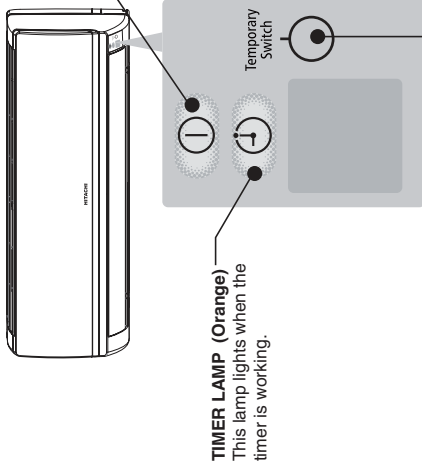

CAUTION

Turn off the circuit breaker if the unit is not be operated for a long period.

☆ If the power stays on and the unit is not operated, power is slightly consumed in the control circuit. The power is saved by turning off the power switch (or the circuit breaker when the power is supplied from the outdoor unit).

MAINTENANCE

⚠ CAUTION

Cleaning and maintenance must be carried out only by qualified service personnel. Before cleaning, stop operation and switch off the power supply.

1. AIR FILTER

Please clean the filter once about every two weeks. By doing so, the power rates are saved. In case the air filter is full of dust, the air flow will decrease and the cooling capacity will be reduced. Further, noise may occur. Be sure to clean the filter following the procedure below.

PROCEDURE

1 Open the front panel carefully and remove the filter.



2 Vacuum dust from the air filter using vacuum cleaner. If there is too much dust, wash the filter with a detergent and rinse it thoroughly. After that, dry it in the shade.



3 Set the filter with "FRONT" mark facing front, and slot them into the original state.
After attaching the filters, push the front panel at three arrow portions as shown in figure and close it.

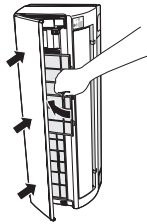

⚠ CAUTION

- Do not wash with hot water at more than 40°C. The filter may shrink.
- When washing it, shake off moisture completely and dry it in the shade; do not expose it directly to the sun. The filter may shrink.
- Don't operate the unit without filter. Fault may occur if you continue.

2. CLEANING OF FRONT PANEL

- Remove the front panel and wash with clean water. Wash it with a soft sponge. After using neutral detergent, wash thoroughly with clean water.
- When front panel is not removed, wipe it with a soft dry cloth. Wipe the remote controller thoroughly with a soft dry cloth.
- Wipe the water thoroughly. If water remains at indicators or signal receiver of indoor unit, it causes trouble.



Method of removing the front panel. Be sure to hold the front panel with both hands to detach and attach it.

Removing the Front Panel

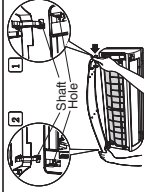

Attaching the Front Panel

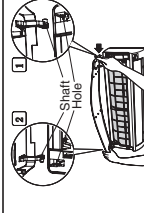

- When the front panel is fully opened with both hands, push the right arm to the inside to release it, and while closing the front panel slightly, put it out forward.
- Move the shafts of the left and right arms into the steps in the unit and securely insert them into the holes.

⚠ CAUTION

- Do not splash or direct water to the body of the unit when cleaning it as this may cause short circuit.
- Never use hot water (above 40°C), benzene, gasoline, acid, thinner or a brush, because they will damage the plastic surface and the coating.



3. MAINTENANCE BEFORE LONG OFF PERIOD

- Run the unit by setting the operation mode to (COOL), the temperature to 32°C and the fan speed to HI for about half a day on a fine day, and dry the whole of the unit.
- Switch off the power plug or turn off the circuit breaker.

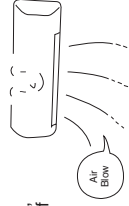

INFORMATION

CAPABILITIES

Heating Capability

- This room air conditioner utilizes a heat pump system that absorbs exterior heat and brings it into a room to be heated. As the ambient temperature gets lower, heating capability will also lower. In such a situation, the inverter work to increase compressor rpm to keep the unit's heating capability from decreasing. If the unit's heating performance is still unsatisfactory, other heating appliances should be used to augment this unit's performance.

- The air conditioner is designed to heat an entire room so that it may take some time before you feel warm. Timer operation is recommended for effective preheating ahead of the desired time.

Cooling and Dehumidifying Capabilities

- If the heat present in a room exceeds the unit's cooling capacity (for example, if there are many people in the room or other heating appliances are used), the preset room temperature may not be reached.

CAUTION

Do not use a stove or any other high temperature devices in proximity to the indoor unit.



PROHIBITION

REGULAR INSPECTION

PLEASE CHECK THE FOLLOWING POINTS EVERY EITHER HALF YEARLY OR YEARLY. CONTACT YOUR SALES AGENT SHOULD YOU NEED ANY HELP.

1	WARNING	Check to see if the unit's earth line has been connected correctly. If the earth line is disconnected or faulty, unit failure or electric shock hazard may result.
2	WARNING	Check to see if the mounting frame has rusted excessively or if the outdoor unit has tilted or become unstable. It could collapse or fall, causing injury.

AFTER SALES SERVICE AND WARRANTY

WHEN ASKING FOR SERVICE, CHECK THE FOLLOWING POINTS.

CONDITION	CHECK THE FOLLOWING POINTS
<p>If the remote controller is not transmitting a signal. (Remote controller display is dim or blank.)</p> <p>When it does not operate.</p>	<ul style="list-style-type: none"> Do the batteries need replacement? Is the polarity of the inserted batteries correct?
<p>When it does not cool well. When it does not heat well.</p>	<ul style="list-style-type: none"> Is the fuse all right? Is the voltage extremely high or low? Is the circuit breaker "ON"? Is the power plug inserted? Do you have any power cut?
<p>When it does not cool well. When it does not heat well.</p>	<ul style="list-style-type: none"> Is the air filter blocked with dust? Is the set temperature suitable? Have horizontal air defectors been adjusted to their correct positions according to the operation mode selected? Are the air inlets or air outlets of indoor and outdoor units blocked? Is the fan speed "LOW" or "SILENT"?

The following phenomena do not indicate unit failure.

<p>During heating, the operation indicator blinks and air blow stops</p>	<p><Operation start> The unit is preparing to blow warm air. Please wait. <In operation> The outdoor unit is defrosting. Please wait.</p>
Hissing or fizzy sounds	Refrigerant flow noise in the pipe or valve sound generated when flow rate is adjusted.
Squeaking noise	Noise generated when the unit expands or contracts due to temperature changes.
Rustling noise	Noise generated with the indoor unit fan's rpm changing such as operation start times.
Clicking noise	Noise of the motorized valve when the unit is switched on.

Perking noise	Noise of the ventilation fan sucking in air present in the drain hose and blowing out dehumidifying water that had accumulated in the condensed water collector. For details, consult your sales agent.
Changing operation noise	Operation noise changes due to power variations according to room temperature changes.
Mist emission	Mist is generated as the air within the room is suddenly cooled by conditioned air.
Steam emitted from the outdoor unit	Water generated during defrosting operation evaporates and steam is emitted.
Odors	Caused as the smells and particles of smoke, food, cosmetics, etc. present in room air become attached to the unit and blown off into the room again.
The outdoor unit continues to operate even if operation is stopped.	Defrosting is underway (as the heating operation is stopped, the microcomputer checks frost accumulated in the outdoor unit and instructs the unit to perform automatic defrosting if necessary).
The OPERATION lamp is blinking.	Shows preheating or defrosting operation is underway. As the protective circuit or preheat sensor operates when unit operation is stopped during preheating and then restarted, or when operation mode is switched from cooling to heating, the lamp continues to blink.
Does not reach the temperature setting	Actual room temperature may deviate slightly from the remote controller's temperature setting depending on the number of people in the room, indoor or outdoor conditions.

- If the unit still fails to operate normally after performing the above inspections, turn the circuit breaker off and contact your sales agent immediately.

Contact your sales agent immediately if the following phenomena should occur:

- The circuit breaker switches off or the fuse blows frequently.
- The switch operation is not stable.
- Foreign matter or water accidentally enters the unit interior.
- The power cord gets excessively hot or its insulation is torn or stripped.
- TIMER lamp on the indoor unit display blinks.

(As the nature of the failure can be identified by the blinking cycle, check the blinking cycle before turning off the circuit breaker.)



Notes

- In quiet operation or stopping the running, the following phenomena may occasionally occur, but they are not abnormal for the operation.
 - (1) Slight flowing noise of refrigerant in the refrigerating cycle.
 - (2) Slight rubbing noise from the fan casing which is cooled and then gradually warmed as operation stops.
- The odor will possibly be emitted from the room air conditioner because the various odor, emitted by smoke, foodstuffs, cosmetics and so on, sticks to it. So please clean the air filter and the evaporator regularly to reduce the odor.

- Please contact your sales agent immediately if the air conditioner still fails to operate normally after the above inspections. Inform your agent of the model of your unit, production number, date of installation. Please also inform him regarding the fault.

Please note:
On switching on the equipment, particularly when the room light is dimmed, a slight brightness fluctuation may occur. This is of no consequence.
The conditions of the local Power Supply Companies are to be observed.

CONSTRUCTION AND DIMENSIONAL DIAGRAM

MODEL RAK-18PEB, RAK-25PEB, RAK-35PEB, RAK-50PEB, RAK-25PEBC, RAK-35PEBC, RAK-50PEBC

INDOOR UNIT

Unit : mm

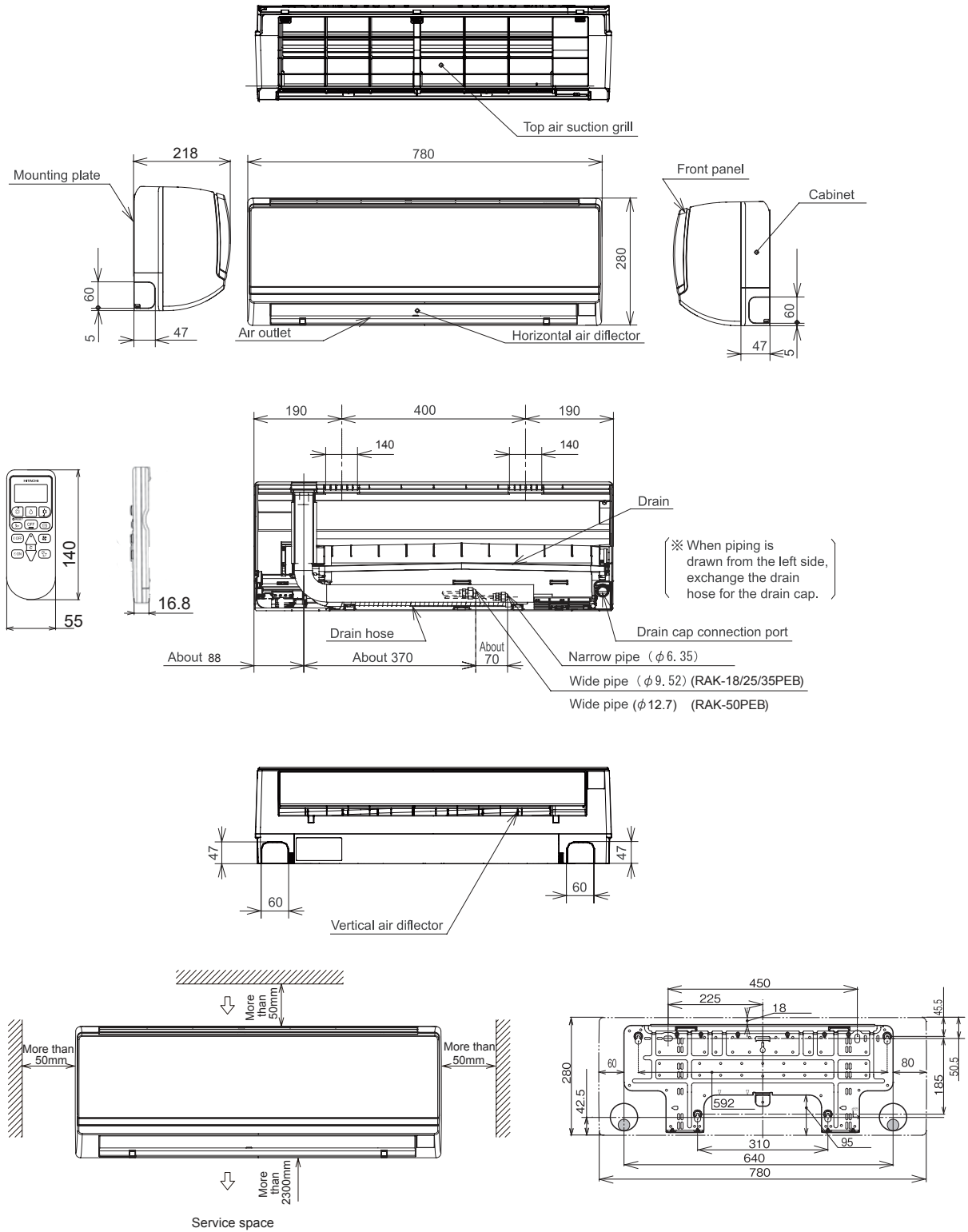

CONSTRUCTION AND DIMENSIONAL DIAGRAM

MODEL RAC-18WEB,RAC-25WEB,35WEB

OUTDOOR UNIT

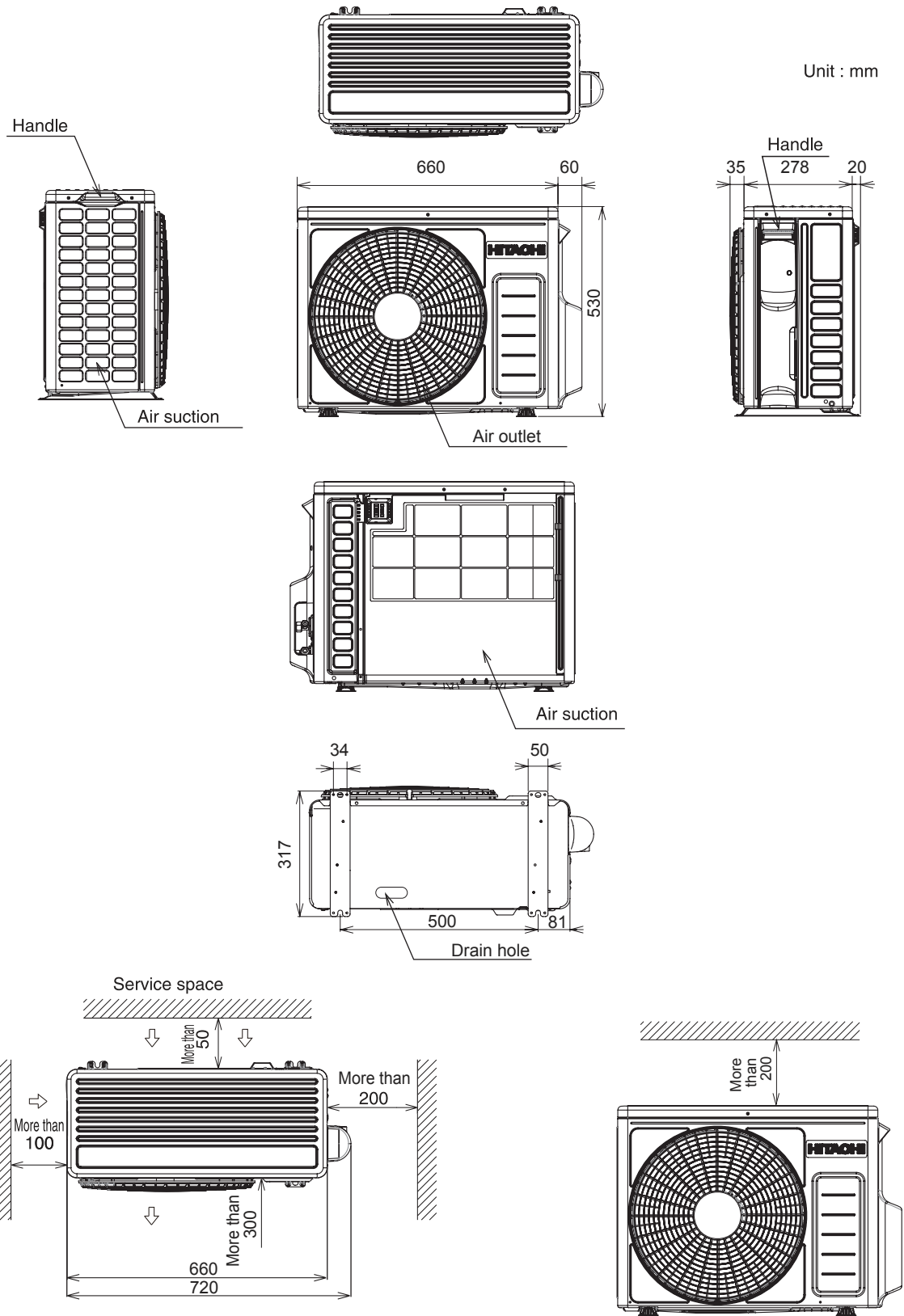

NOTE:

- 1.For outdoor unit installation , allow at least 2 sides of space around the unit ensure ventilation flue.
- 2.The connecting pipe , should all the insulated with insulation pipe.
- 3.Piping length is within 20m.
- 4.Height different of the piping between the indoor unit and outdoor unit should be within 10m.

CONSTRUCTION AND DIMENSIONAL DIAGRAM

MODEL RAC-50WEB

OUTDOOR UNIT

Unit : mm

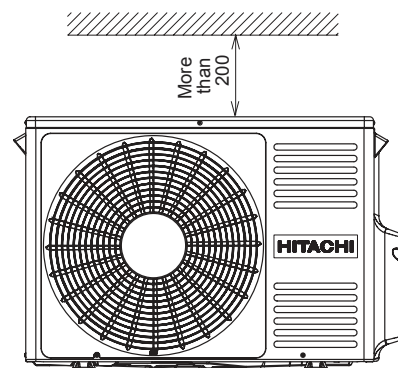
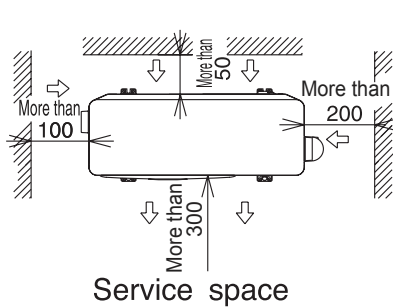
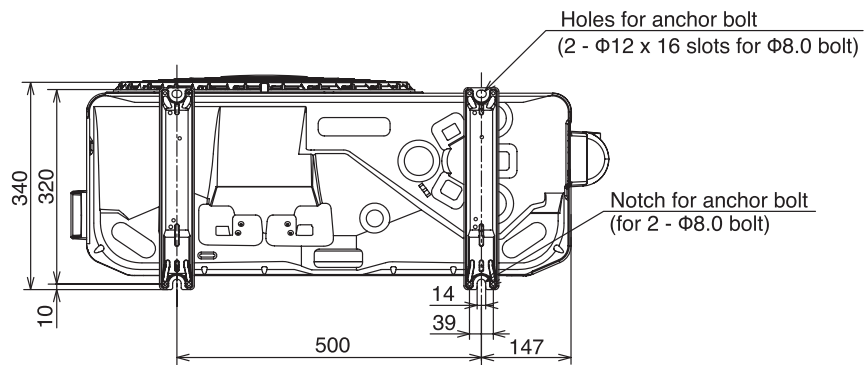
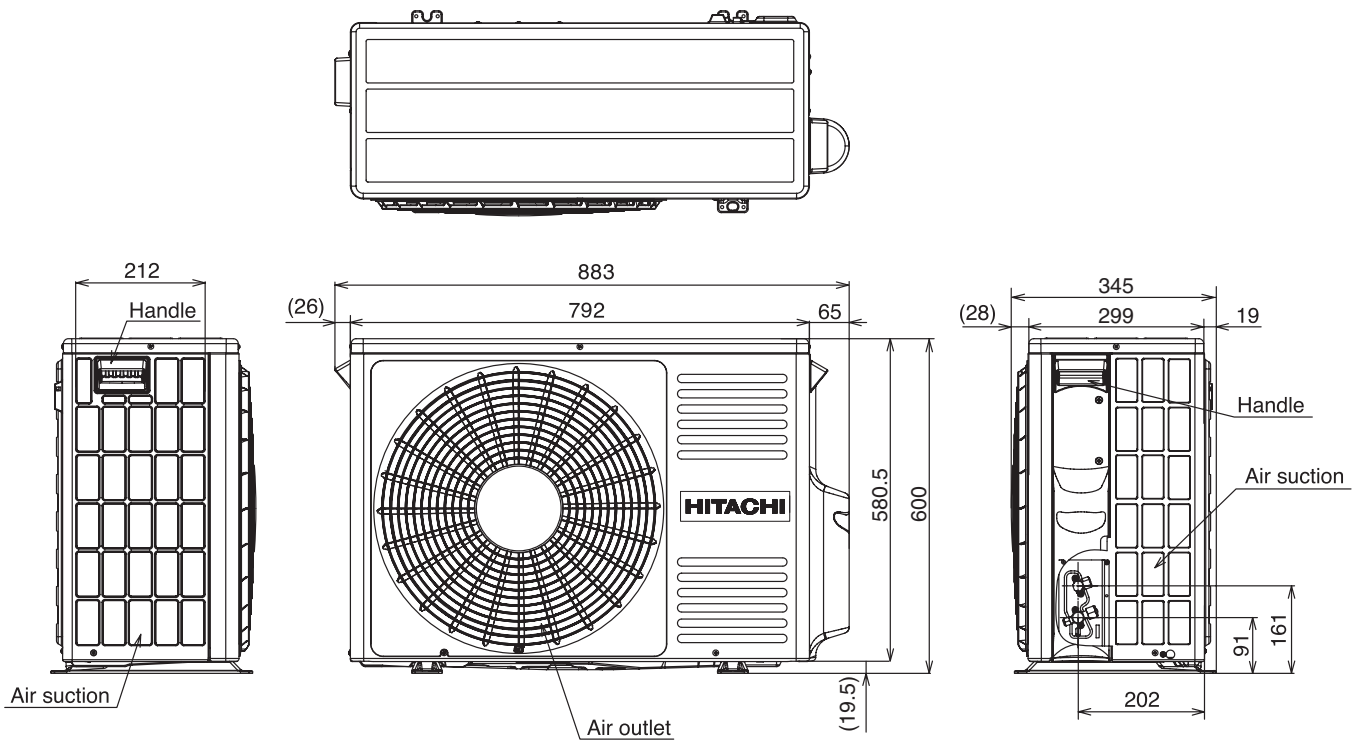

NOTE:

1. For outdoor unit installation, allow at least 2 sides of space around the unit ensure ventilation flue.
2. The connecting pipe, should all the insulated with insulation pipe.
3. Piping length is within 20m.
4. Height different of the piping between the indoor unit and outdoor unit should be within 10m.

MAIN PARTS COMPONENT

THERMOSTAT (Room temperature Thermistor)

Thermostat Specifications

MODEL			RAK-18PEB,RAK-25PEB,RAK-35PEB,RAK-50PEB RAK-25PEBC,RAK-35PEBC,RAK-50PEBC		
THERMOSTAT MODEL			IC		
OPERATION MODE			COOL		HEAT
TEMPERATURE °C (°F)	INDICATION 16	ON	15.3	(59.54)	16.7 (62.06)
		OFF	15.0	(59.00)	16.7 (62.06)
	INDICATION 24	ON	23.3	(73.94)	24.7 (76.46)
		OFF	23.0	(73.40)	24.7 (76.46)
	INDICATION 32	ON	31.3	(88.34)	32.7 (90.86)
		OFF	31.0	(87.80)	32.7 (90.86)

FAN MOTOR

Fan Motor Specifications

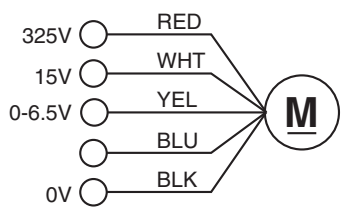
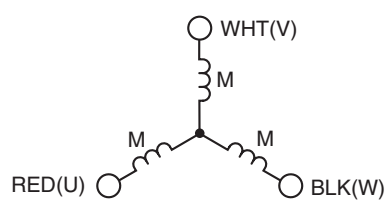
MODEL	RAK-18/25/35/50PEB RAK-25/35/50PEBC	RAC-18/25/35/50WEB
POWER SOURCE	DC : 325V	DC : 120 - 380V
OUTPUT	30W	47W
CONNECTION	 <p>(Control circuit built in)</p>	

BLU : BLUE
GRY : GRAY
BLK : BLACK

YEL : YELLOW
ORN : ORANGE
PNK : PINK

BRN : BROWN
GRN : GREEN
VIO : VIOLET

WHT : WHITE
RED : RED

MAIN ELECTRIC COMPONENTS FOR OUTDOOR UNIT

NAME	RATING	APPLICABLE MODELS
REACTOR	15 (mH) 230 mΩ MAX (20 °C)	RAC-18/25/35WEB
	5.3 (mH), 67mΩ	RAC-50WEB

COMPRESSOR MOTOR

Compressor Motor Specifications

MODEL		RAC-18/25/35WEB	RAC-50WEB
COMPRESSOR TYPE		ASD084SFNA7JK1	ASG133CDNB7AT
POWER SOURCE		100 - 240 V	220 - 350 V
CONNECTION			
RESISTANCE VALUE (Ω)	20°C	2M= 0.74	2M= 2.4
	75°C	2M= 0.88	2M= 2.0

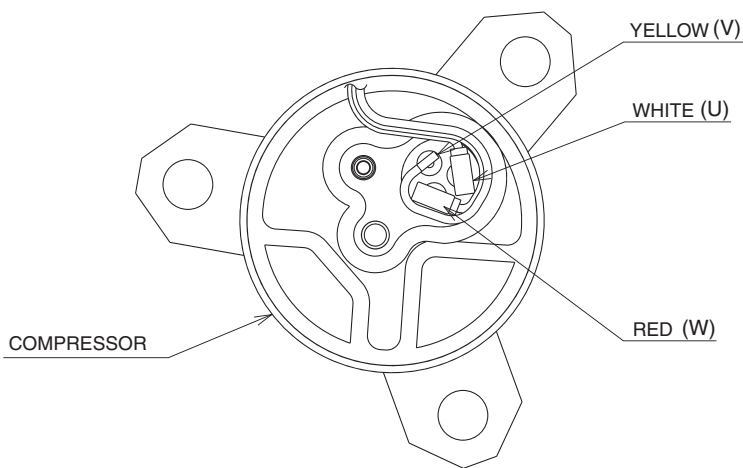

RAC-18/25/35WEB

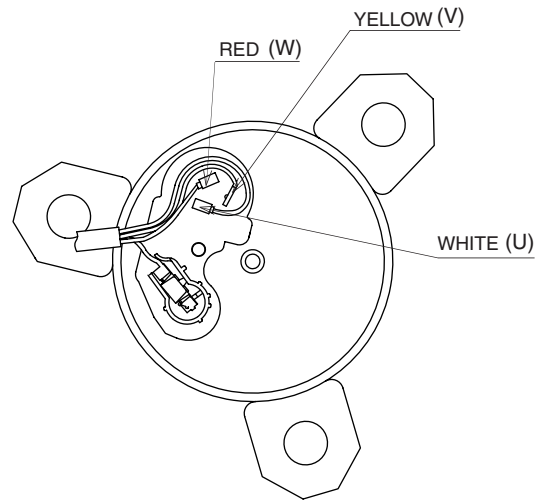

RAC-50WEB

CAUTION

When the refrigerating cycle has been operated for a long time with the capillary tubes clogged or crushed or with too little refrigerant, check the color of the refrigerating machine oil inside the compressor. If the color has been changed conspicuously, replace the compressor.

WIRING DIAGRAM OF THE PRINTED WIRING BOARD

[Remote controller] RAR-5F1

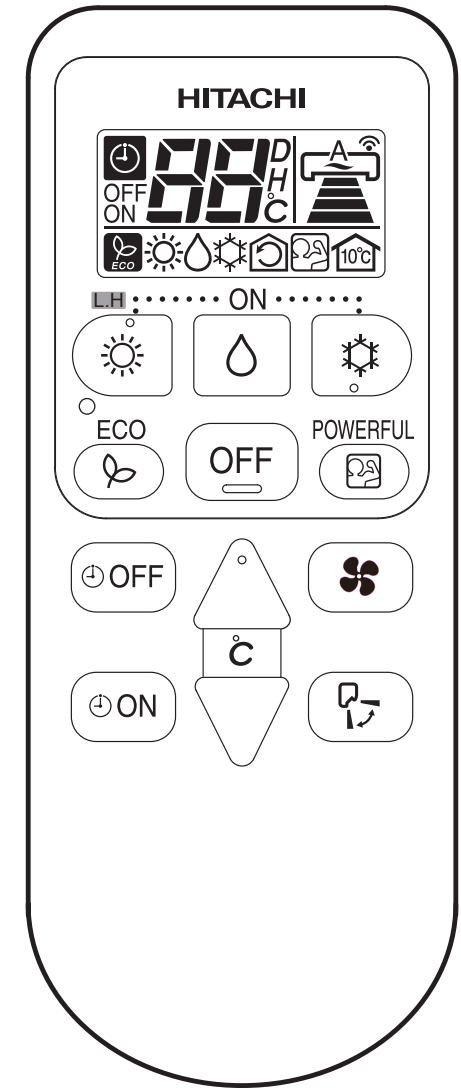
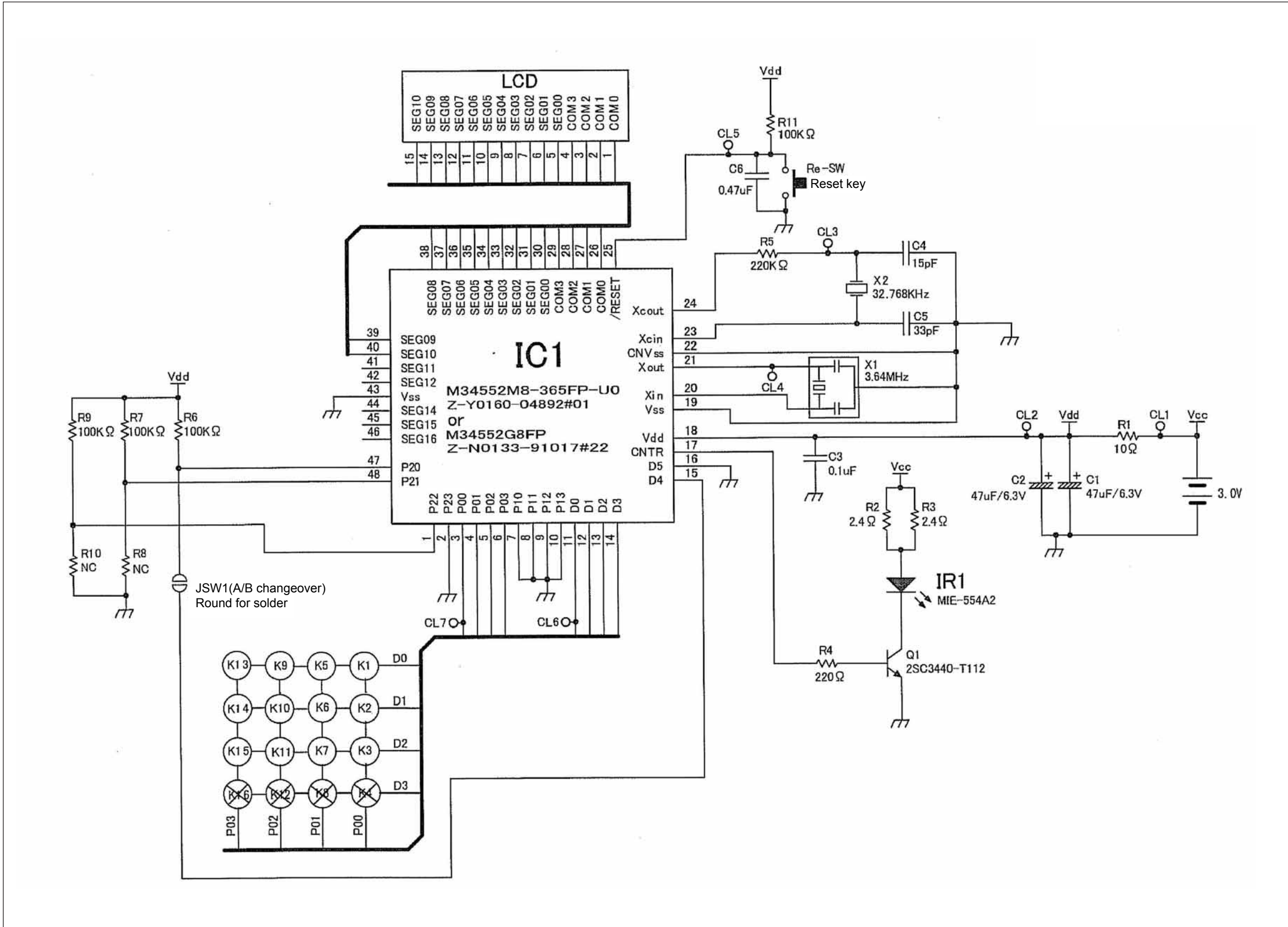

CIRCUIT DIAGRAM

MODEL RAK-18/25/35/50PEB

RAK-25/35/50PEBC

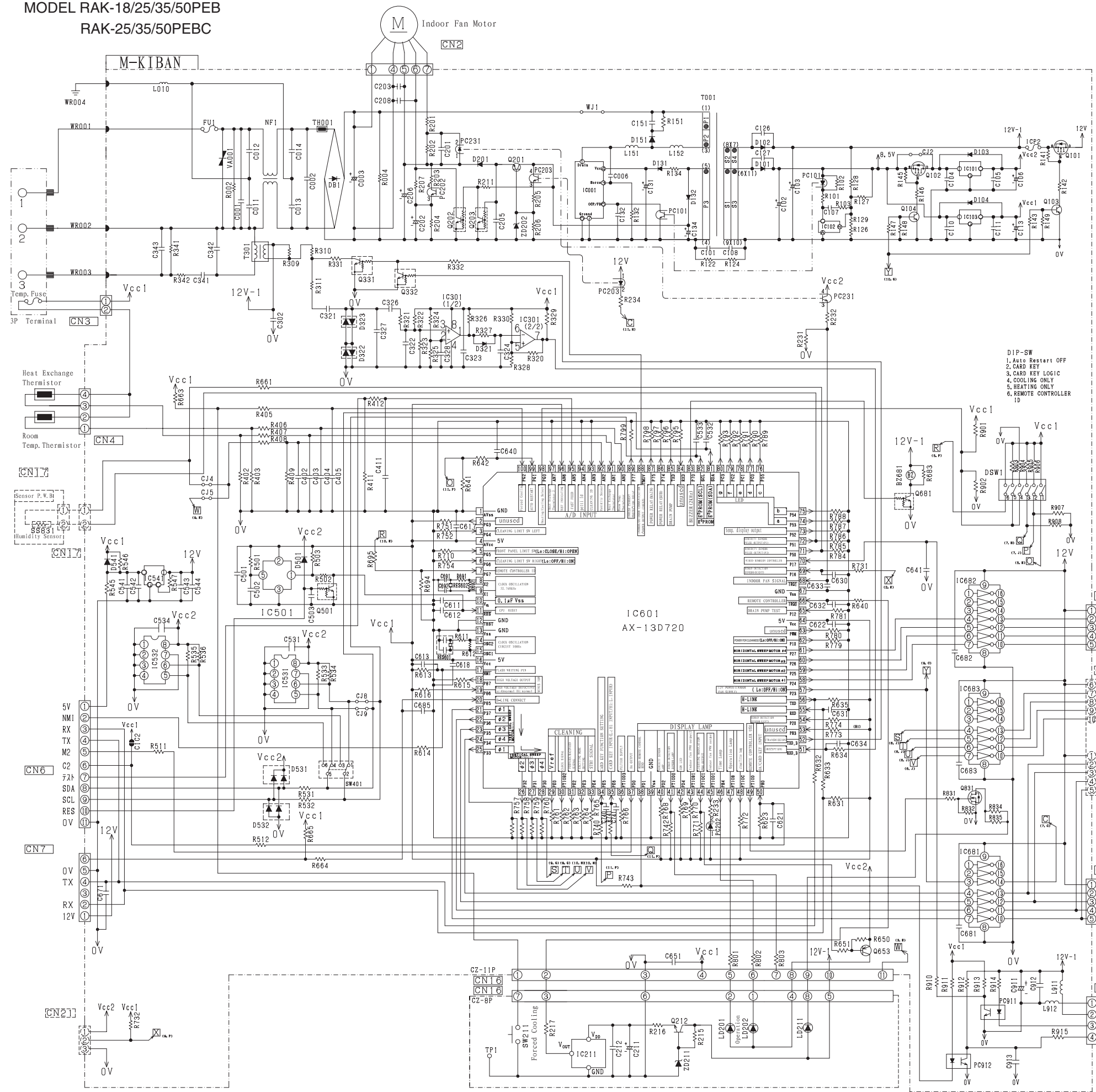

RESISTOR		RESISTOR		Capacitor		WIRE	
Part No.	Value	Part No.	Value	Part No.	Value	Part No.	Value
R001	10K	R763	10K	C618	0.1u	W001	0.5mm
R002	680K	R764	10K	C619	0.1u	W002	0.5mm
R003	10K	R765	10K	C620	0.1u	W003	0.5mm
R004	1M	R766	10K	C621	0.1u	W004	0.5mm
R005	10K	R767	10K	C622	0.1u	W005	0.5mm
R006	10K	R768	10K	C623	0.1u	W006	0.5mm
R007	10K	R769	10K	C624	0.1u	W007	0.5mm
R008	10K	R770	10K	C625	0.1u	W008	0.5mm
R009	10K	R771	10K	C626	0.1u	W009	0.5mm
R010	10K	R772	10K	C627	0.1u	W010	0.5mm
R011	10K	R773	10K	C628	0.1u	W011	0.5mm
R012	10K	R774	10K	C629	0.1u	W012	0.5mm
R013	10K	R775	10K	C630	0.1u	W013	0.5mm
R014	10K	R776	10K	C631	0.1u	W014	0.5mm
R015	10K	R777	10K	C632	0.1u	W015	0.5mm
R016	10K	R778	10K	C633	0.1u	W016	0.5mm
R017	10K	R779	10K	C634	0.1u	W017	0.5mm
R018	10K	R780	10K	C635	0.1u	W018	0.5mm
R019	10K	R781	10K	C636	0.1u	W019	0.5mm
R020	10K	R782	10K	C637	0.1u	W020	0.5mm
R021	10K	R783	10K	C638	0.1u	W021	0.5mm
R022	10K	R784	10K	C639	0.1u	W022	0.5mm
R023	10K	R785	10K	C640	0.1u	W023	0.5mm
R024	10K	R786	10K	C641	0.1u	W024	0.5mm
R025	10K	R787	10K	C642	0.1u	W025	0.5mm
R026	10K	R788	10K	C643	0.1u	W026	0.5mm
R027	10K	R789	10K	C644	0.1u	W027	0.5mm
R028	10K	R790	10K	C645	0.1u	W028	0.5mm
R029	10K	R791	10K	C646	0.1u	W029	0.5mm
R030	10K	R792	10K	C647	0.1u	W030	0.5mm
R031	10K	R793	10K	C648	0.1u	W031	0.5mm
R032	10K	R794	10K	C649	0.1u	W032	0.5mm
R033	10K	R795	10K	C650	0.1u	W033	0.5mm
R034	10K	R796	10K	C651	0.1u	W034	0.5mm
R035	10K	R797	10K	C652	0.1u	W035	0.5mm
R036	10K	R798	10K	C653	0.1u	W036	0.5mm
R037	10K	R799	10K	C654	0.1u	W037	0.5mm
R038	10K	R800	10K	C655	0.1u	W038	0.5mm
R039	10K	R801	10K	C656	0.1u	W039	0.5mm
R040	10K	R802	10K	C657	0.1u	W040	0.5mm
R041	10K	R803	10K	C658	0.1u	W041	0.5mm
R042	10K	R804	10K	C659	0.1u	W042	0.5mm
R043	10K	R805	10K	C660	0.1u	W043	0.5mm
R044	10K	R806	10K	C661	0.1u	W044	0.5mm
R045	10K	R807	10K	C662	0.1u	W045	0.5mm
R046	10K	R808	10K	C663	0.1u	W046	0.5mm
R047	10K	R809	10K	C664	0.1u	W047	0.5mm
R048	10K	R810	10K	C665	0.1u	W048	0.5mm
R049	10K	R811	10K	C666	0.1u	W049	0.5mm
R050	10K	R812	10K	C667	0.1u	W050	0.5mm
R051	10K	R813	10K	C668	0.1u	W051	0.5mm
R052	10K	R814	10K	C669	0.1u	W052	0.5mm
R053	10K	R815	10K	C670	0.1u	W053	0.5mm
R054	10K	R816	10K	C671	0.1u	W054	0.5mm
R055	10K	R817	10K	C672	0.1u	W055	0.5mm
R056	10K	R818	10K	C673	0.1u	W056	0.5mm
R057	10K	R819	10K	C674	0.1u	W057	0.5mm
R058	10K	R820	10K	C675	0.1u	W058	0.5mm
R059	10K	R821	10K	C676	0.1u	W059	0.5mm
R060	10K	R822	10K	C677	0.1u	W060	0.5mm
R061	10K	R823	10K	C678	0.1u	W061	0.5mm
R062	10K	R824	10K	C679	0.1u	W062	0.5mm
R063	10K	R825	10K	C680	0.1u	W063	0.5mm
R064	10K	R826	10K	C681	0.1u	W064	0.5mm
R065	10K	R827	10K	C682	0.1u	W065	0.5mm
R066	10K	R828	10K	C683	0.1u	W066	0.5mm
R067	10K	R829	10K	C684	0.1u	W067	0.5mm
R068	10K	R830	10K	C685	0.1u	W068	0.5mm
R069	10K	R831	10K	C686	0.1u	W069	0.5mm
R070	10K	R832	10K	C687	0.1u	W070	0.5mm
R071	10K	R833	10K	C688	0.1u	W071	0.5mm
R072	10K	R834	10K	C689	0.1u	W072	0.5mm
R073	10K	R835	10K	C690	0.1u	W073	0.5mm
R074	10K	R836	10K	C691	0.1u	W074	0.5mm
R075	10K	R837	10K	C692	0.1u	W075	0.5mm
R076	10K	R838	10K	C693	0.1u	W076	0.5mm
R077	10K	R839	10K	C694	0.1u	W077	0.5mm
R078	10K	R840	10K	C695	0.1u	W078	0.5mm
R079	10K	R841	10K	C696	0.1u	W079	0.5mm
R080	10K	R842	10K	C697	0.1u	W080	0.5mm
R081	10K	R843	10K	C698	0.1u	W081	0.5mm
R082	10K	R844	10K	C699	0.1u	W082	0.5mm
R083	10K	R845	10K	C700	0.1u	W083	0.5mm
R084	10K	R846	10K	C701	0.1u	W084	0.5mm
R085	10K	R847	10K	C702	0.1u	W085	0.5mm
R086	10K	R848	10K	C703	0.1u	W086	0.5mm
R087	10K	R849	10K	C704	0.1u	W087	0.5mm
R088	10K	R850	10K	C705	0.1u	W088	0.5mm
R089	10K	R851	10K	C706	0.1u	W089	0.5mm
R090	10K	R852	10K	C707	0.1u	W090	0.5mm
R091	10K	R853	10K	C708	0.1u	W091	0.5mm
R092	10K	R854	10K	C709	0.1u	W092	0.5mm
R093	10K	R855	10K	C710	0.1u	W093	0.5mm
R094	10K	R856	10K	C711	0.1u	W094	0.5mm
R095	10K	R857	10K	C712	0.1u	W095	0.5mm
R096	10K	R858	10K	C713	0.1u	W096	0.5mm
R097	10K	R859	10K	C714	0.1u	W097	0.5mm
R098	10K	R860	10K	C715	0.1u	W098	0.5mm
R099	10K	R861	10K	C716	0.1u	W099	0.5mm
R100	10K	R862	10K	C717	0.1u	W100	0.5mm
R101	10K	R863	10K	C718	0.1u	W101	0.5mm
R102	10K	R864	10K	C719	0.1u	W102	0.5mm
R103	10K	R865	10K	C720	0.1u	W103	0.5mm
R104	10K	R866	10K	C721	0.1u	W104	0.5mm
R105	10K	R867	10K	C722	0.1u	W105	0.5mm
R106	10K	R868	10K	C723	0.1u	W106	0.5mm
R107	10K	R869	10K	C724	0.1u	W107	0.5mm
R108	10K	R870	10K	C725	0.1u	W108	0.5mm
R109	10K	R871	10K	C726	0.1u	W109	0.5mm
R110	10K	R872	10K	C727	0.1u	W110	0.5mm
R111	10K	R873	10K	C728	0.1u	W111	0.5mm
R112	10K	R874	10K	C729	0.1u	W112	0.5mm
R113	10K	R875	10K	C730	0.1u	W113	0.5mm
R114	10K	R876	10K	C731	0.1u	W114	0.5mm
R115	10K	R877	10K	C732	0.1u	W115	0.5mm
R116	10K	R878	10K	C733	0.1u	W116	0.5mm
R117	10K	R879	10K	C734	0.1u	W117	0.5mm
R118	10K	R880	10K	C735	0.1u	W118	0.5mm
R119	10K	R881	10K	C736	0.1u	W119	0.5mm
R120	10K	R882	10K	C737	0.1u	W120	0.5mm
R121	10K	R883	10K	C738	0.1u	W121	0.5mm
R122	10K	R884	10K	C739	0.1u	W122	0.5mm
R123	10K	R885	10K	C740	0.1u	W123	0.5mm
R124	10K	R886	10K	C741	0.1u	W124	0.5mm
R125	10K	R887	10K	C742	0.1u	W125	0.5mm
R126	10K	R888	10K	C743	0.1u	W126	0.5mm
R127	10K	R889	10K	C744	0.1u	W127	0.5mm
R128	10K	R890	10K	C745	0.1u	W128	0.5mm
R129	10K	R891	10K	C746	0.1u	W129	0.5mm
R130	10K	R892	10K	C747	0.1u	W130	0.5mm
R131	10K	R893	10K	C748	0.1u	W131	0.5mm
R132	10K	R894	10K	C749	0.1u	W132	0.5mm
R133	10K	R895	10K	C750	0.1u	W133	0.5mm
R134	10K	R896	10K	C751	0.1u	W134	0.5mm
R135	10K	R897	10K	C752	0.1u	W135	0.5mm
R136	10K	R898	10K	C753	0.1u	W136	0.5mm
R137	10K	R899	10K	C754	0.1u	W137	0.5mm
R138	10K	R900	10K	C755	0.1u	W138	0.5mm
R139	10K	R901	10K	C756	0.1u	W139	0.5mm
R140	10K	R902	10K	C757	0.1u	W140	0.5mm
R141	10K	R903	10K	C758	0.1u	W141	0.5mm
R142	10K	R904	10K	C759	0.1u	W142	0.5mm
R143	10K	R905	10K	C760	0.1u	W143	0.5mm
R144	10K	R906	10K	C761	0.1u	W144	0.5mm
R145	10K	R907	10K	C762	0.1u	W145	0.5mm
R146	10K	R908	10K	C763	0.1u	W146	0.5mm
R147							

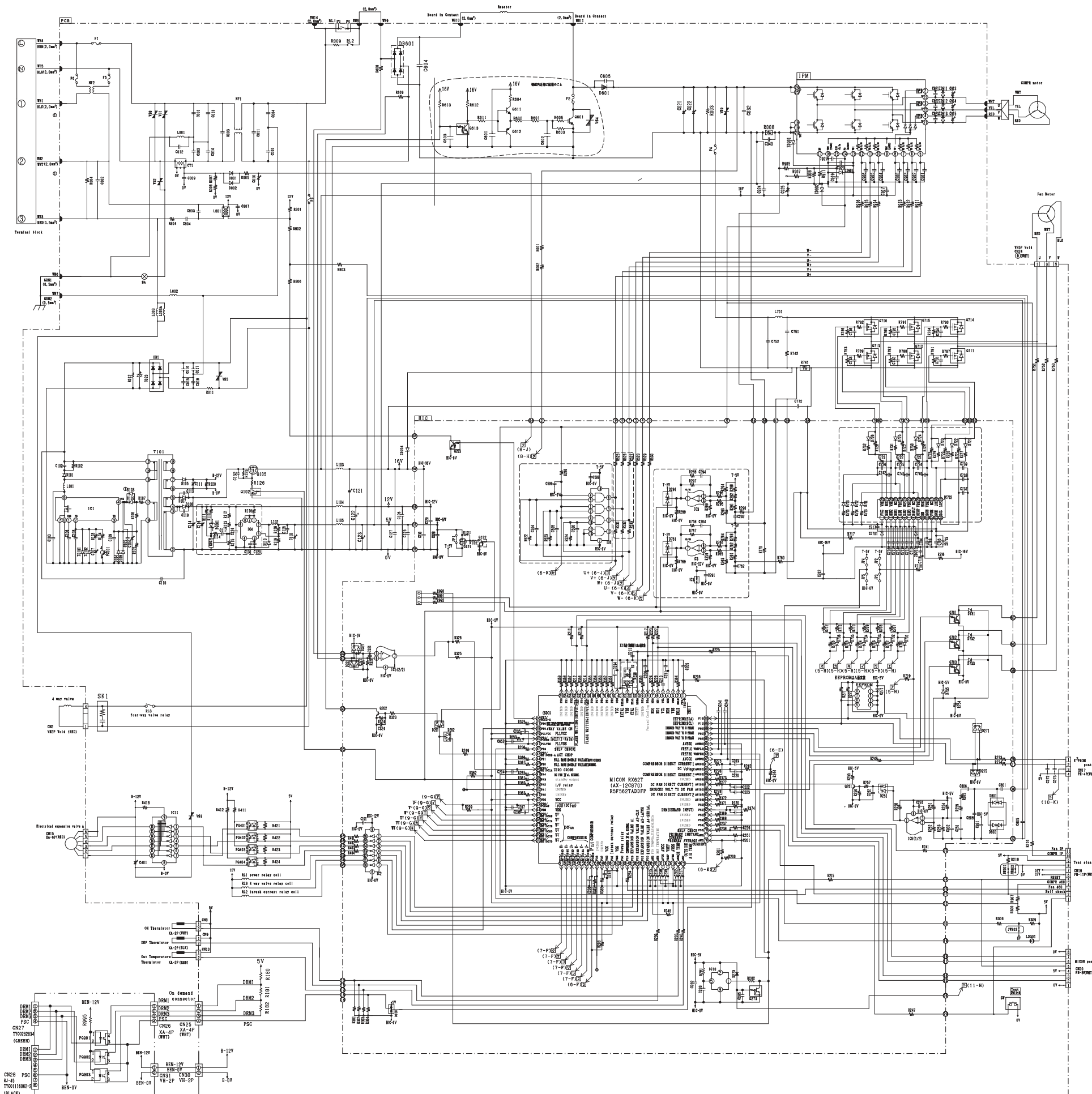

Mounting PCB
M: Main PCB (BOARD-AS)

Way of mount part
A: Aisle inserter
R: Radial inserter
B: Radial inserter (7.5mm pitch)
H: Head inserter
C: Chip

Resistor

Part No.	Value	Part No.	Value
R001	100Ω	R411	50kΩ
R002	100Ω	R412	50kΩ
R003	100Ω	R413	50kΩ
R004	100Ω	R414	50kΩ
R005	100Ω	R415	50kΩ
R006	100Ω	R416	50kΩ
R007	100Ω	R417	50kΩ
R008	100Ω	R418	50kΩ
R009	100Ω	R419	50kΩ
R010	100Ω	R420	50kΩ
R011	100Ω	R421	50kΩ
R012	100Ω	R422	50kΩ
R013	100Ω	R423	50kΩ
R014	100Ω	R424	50kΩ
R015	100Ω	R425	50kΩ
R016	100Ω	R426	50kΩ
R017	100Ω	R427	50kΩ
R018	100Ω	R428	50kΩ
R019	100Ω	R429	50kΩ
R020	100Ω	R430	50kΩ
R021	100Ω	R431	50kΩ
R022	100Ω	R432	50kΩ
R023	100Ω	R433	50kΩ
R024	100Ω	R434	50kΩ
R025	100Ω	R435	50kΩ
R026	100Ω	R436	50kΩ
R027	100Ω	R437	50kΩ
R028	100Ω	R438	50kΩ
R029	100Ω	R439	50kΩ
R030	100Ω	R440	50kΩ
R031	100Ω	R441	50kΩ
R032	100Ω	R442	50kΩ
R033	100Ω	R443	50kΩ
R034	100Ω	R444	50kΩ
R035	100Ω	R445	50kΩ
R036	100Ω	R446	50kΩ
R037	100Ω	R447	50kΩ
R038	100Ω	R448	50kΩ
R039	100Ω	R449	50kΩ
R040	100Ω	R450	50kΩ
R041	100Ω	R451	50kΩ
R042	100Ω	R452	50kΩ
R043	100Ω	R453	50kΩ
R044	100Ω	R454	50kΩ
R045	100Ω	R455	50kΩ
R046	100Ω	R456	50kΩ
R047	100Ω	R457	50kΩ
R048	100Ω	R458	50kΩ
R049	100Ω	R459	50kΩ
R050	100Ω	R460	50kΩ
R051	100Ω	R461	50kΩ
R052	100Ω	R462	50kΩ
R053	100Ω	R463	50kΩ
R054	100Ω	R464	50kΩ
R055	100Ω	R465	50kΩ
R056	100Ω	R466	50kΩ
R057	100Ω	R467	50kΩ
R058	100Ω	R468	50kΩ
R059	100Ω	R469	50kΩ
R060	100Ω	R470	50kΩ
R061	100Ω	R471	50kΩ
R062	100Ω	R472	50kΩ
R063	100Ω	R473	50kΩ
R064	100Ω	R474	50kΩ
R065	100Ω	R475	50kΩ
R066	100Ω	R476	50kΩ
R067	100Ω	R477	50kΩ
R068	100Ω	R478	50kΩ
R069	100Ω	R479	50kΩ
R070	100Ω	R480	50kΩ
R071	100Ω	R481	50kΩ
R072	100Ω	R482	50kΩ
R073	100Ω	R483	50kΩ
R074	100Ω	R484	50kΩ
R075	100Ω	R485	50kΩ
R076	100Ω	R486	50kΩ
R077	100Ω	R487	50kΩ
R078	100Ω	R488	50kΩ
R079	100Ω	R489	50kΩ
R080	100Ω	R490	50kΩ
R081	100Ω	R491	50kΩ
R082	100Ω	R492	50kΩ
R083	100Ω	R493	50kΩ
R084	100Ω	R494	50kΩ
R085	100Ω	R495	50kΩ
R086	100Ω	R496	50kΩ
R087	100Ω	R497	50kΩ
R088	100Ω	R498	50kΩ
R089	100Ω	R499	50kΩ
R090	100Ω	R500	50kΩ
R091	100Ω	R501	50kΩ
R092	100Ω	R502	50kΩ
R093	100Ω	R503	50kΩ
R094	100Ω	R504	50kΩ
R095	100Ω	R505	50kΩ
R096	100Ω	R506	50kΩ
R097	100Ω	R507	50kΩ
R098	100Ω	R508	50kΩ
R099	100Ω	R509	50kΩ
R100	100Ω	R510	50kΩ
R101	100Ω	R511	50kΩ
R102	100Ω	R512	50kΩ
R103	100Ω	R513	50kΩ
R104	100Ω	R514	50kΩ
R105	100Ω	R515	50kΩ
R106	100Ω	R516	50kΩ
R107	100Ω	R517	50kΩ
R108	100Ω	R518	50kΩ
R109	100Ω	R519	50kΩ
R110	100Ω	R520	50kΩ
R111	100Ω	R521	50kΩ
R112	100Ω	R522	50kΩ
R113	100Ω	R523	50kΩ
R114	100Ω	R524	50kΩ
R115	100Ω	R525	50kΩ
R116	100Ω	R526	50kΩ
R117	100Ω	R527	50kΩ
R118	100Ω	R528	50kΩ
R119	100Ω	R529	50kΩ
R120	100Ω	R530	50kΩ
R121	100Ω	R531	50kΩ
R122	100Ω	R532	50kΩ
R123	100Ω	R533	50kΩ
R124	100Ω	R534	50kΩ
R125	100Ω	R535	50kΩ
R126	100Ω	R536	50kΩ
R127	100Ω	R537	50kΩ
R128	100Ω	R538	50kΩ
R129	100Ω	R539	50kΩ
R130	100Ω	R540	50kΩ
R131	100Ω	R541	50kΩ
R132	100Ω	R542	50kΩ
R133	100Ω	R543	50kΩ
R134	100Ω	R544	50kΩ
R135	100Ω	R545	50kΩ
R136	100Ω	R546	50kΩ
R137	100Ω	R547	50kΩ
R138	100Ω	R548	50kΩ
R139	100Ω	R549	50kΩ
R140	100Ω	R550	50kΩ
R141	100Ω	R551	50kΩ
R142	100Ω	R552	50kΩ
R143	100Ω	R553	50kΩ
R144	100Ω	R554	50kΩ
R145	100Ω	R555	50kΩ
R146	100Ω	R556	50kΩ
R147	100Ω	R557	50kΩ
R148	100Ω	R558	50kΩ
R149	100Ω	R559	50kΩ
R150	100Ω	R560	50kΩ
R151	100Ω	R561	50kΩ
R152	100Ω	R562	50kΩ
R153	100Ω	R563	50kΩ
R154	100Ω	R564	50kΩ
R155	100Ω	R565	50kΩ
R156	100Ω	R566	50kΩ
R157	100Ω	R567	50kΩ
R158	100Ω	R568	50kΩ
R159	100Ω	R569	50kΩ
R160	100Ω	R570	50kΩ
R161	100Ω	R571	50kΩ
R162	100Ω	R572	50kΩ
R163	100Ω	R573	50kΩ
R164	100Ω	R574	50kΩ
R165	100Ω	R575	50kΩ
R166	100Ω	R576	50kΩ
R167	100Ω	R577	50kΩ
R168	100Ω	R578	50kΩ
R169	100Ω	R579	50kΩ
R170	100Ω	R580	50kΩ
R171	100Ω	R581	50kΩ
R172	100Ω	R582	50kΩ
R173	100Ω	R583	50kΩ
R174	100Ω	R584	50kΩ
R175	100Ω	R585	50kΩ
R176	100Ω	R586	50kΩ
R177	100Ω	R587	50kΩ
R178	100Ω	R588	50kΩ
R179	100Ω	R589	50kΩ
R180	100Ω	R590	50kΩ
R181	100Ω	R591	50kΩ
R182	100Ω	R592	50kΩ
R183	100Ω	R593	50kΩ
R184	100Ω	R594	50kΩ
R185	100Ω	R595	50kΩ
R186	100Ω	R596	50kΩ
R187	100Ω	R597	50kΩ
R188	100Ω	R598	50kΩ
R189	100Ω	R599	50kΩ
R190	100Ω	R600	50kΩ
R191	100Ω	R601	50kΩ
R192	100Ω	R602	50kΩ
R193	100Ω	R603	50kΩ
R194	100Ω	R604	50kΩ
R195	100Ω	R605	50kΩ
R196	100Ω	R606	50kΩ
R197	100Ω	R607	50kΩ
R198	100Ω	R608	50kΩ
R199	100Ω	R609	50kΩ
R200	100Ω	R610	50kΩ
R201	100Ω	R611	50kΩ
R202	100Ω	R612	50kΩ
R203	100Ω	R613	50kΩ
R204	100Ω	R614	50kΩ
R205	100Ω	R615	50kΩ
R206	100Ω	R616	50kΩ
R207	100Ω	R617	50kΩ
R208	100Ω	R618	50kΩ
R209	100Ω	R619	50kΩ
R210	100Ω	R620	50kΩ
R211	100Ω	R621	50kΩ
R212	100Ω	R622	50kΩ
R213	100Ω	R623	50kΩ
R214	100Ω	R624	50kΩ
R215	100Ω	R625	50kΩ
R216	100Ω	R626	50kΩ
R217	100Ω	R627	50kΩ
R218	100Ω	R628	50kΩ
R219	100Ω	R629	50kΩ
R220	100Ω	R630	50kΩ
R221	100Ω	R631	50kΩ
R222	100Ω	R632	50kΩ
R223	100Ω	R633	50kΩ
R224	100Ω	R634	50kΩ
R225	100Ω	R635	50kΩ
R226	100Ω	R636	50kΩ
R227	100Ω	R637	50kΩ
R228	100Ω	R638	50kΩ
R229	100Ω	R639	50kΩ
R230	100Ω	R640	50kΩ
R231	100Ω	R641	50kΩ
R232	100Ω	R642	50kΩ
R233	100Ω	R643	50kΩ
R234	100Ω	R644	50kΩ
R235	100Ω	R645	50kΩ
R236	100Ω	R646	50kΩ
R237	100Ω	R647	50kΩ
R238	100Ω	R648	50kΩ
R239	100Ω	R649	50kΩ
R240	100Ω	R650	50kΩ
R241	100Ω	R651	50kΩ
R242	100Ω	R652	50kΩ
R243	100Ω	R653	50kΩ
R244	100Ω	R654	50kΩ
R245	100Ω	R655	50kΩ
R246	100Ω	R656	50kΩ
R247	100Ω	R657	50kΩ
R248	100Ω	R658	50kΩ
R249	100Ω	R659	50kΩ
R250	100Ω	R660	50kΩ
R251	100Ω	R661	50kΩ
R252	100Ω	R662	50kΩ
R253	100Ω	R663	50kΩ
R254	100Ω	R664	50kΩ
R255	100Ω	R665	50kΩ
R256	100Ω	R666	50kΩ
R257	100Ω	R667	50kΩ
R258	100Ω	R668	50kΩ
R259	100Ω	R669	50kΩ
R260	100Ω	R670	50kΩ
R261	100Ω	R671	50kΩ
R262	100Ω	R672	50kΩ
R263	100Ω	R673	50kΩ
R264	100Ω	R674	50kΩ
R265	100Ω	R675	50kΩ
R266	100Ω		

MODEL RAC-50WEB

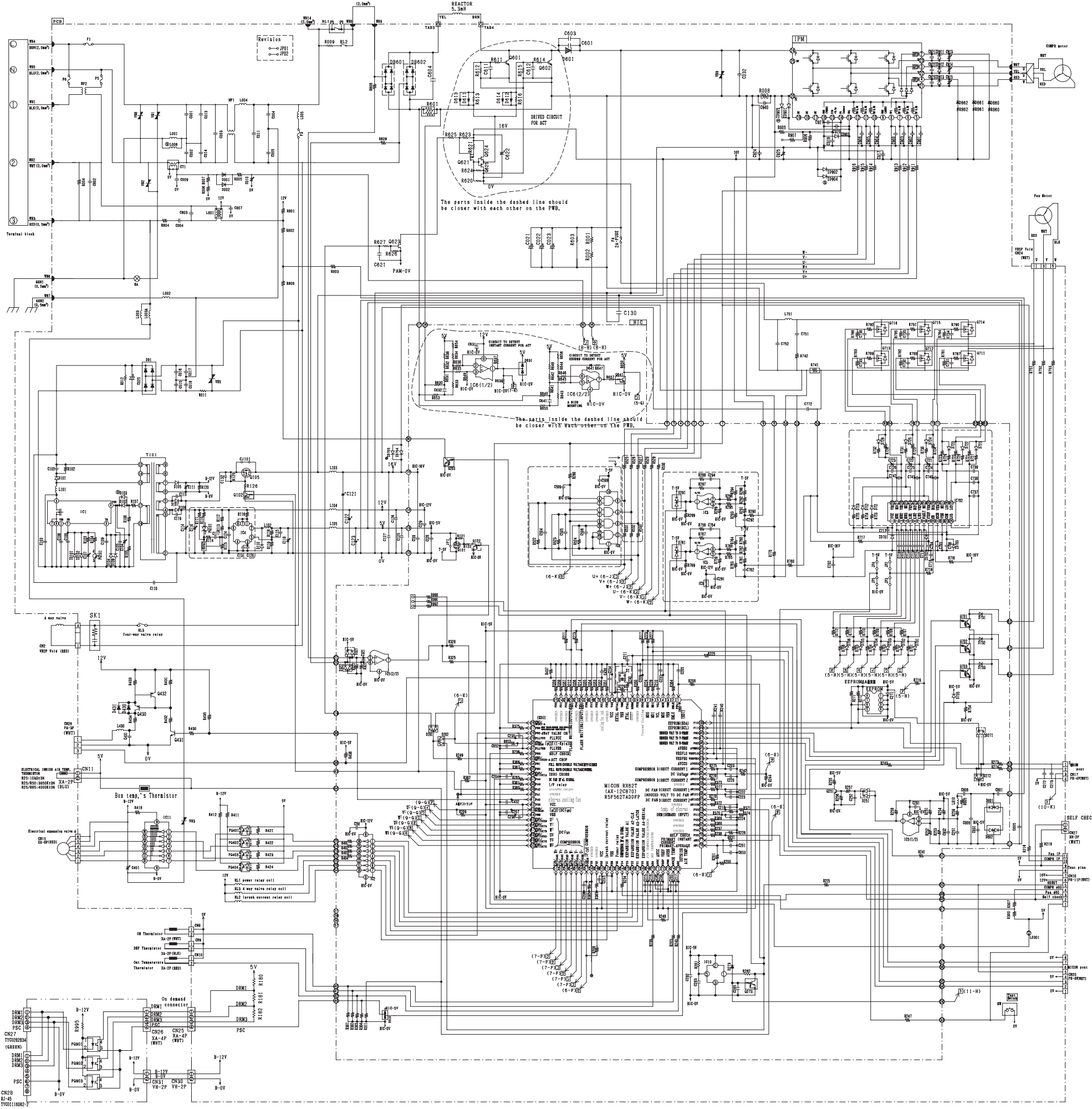

Mounting PCB
M: Metal PCB (IMBOARD-45)
Way of mount mark
A: Axial Insertion
R: Radial Insertion
S: Radial Insertion (7.5mm pitch)
B: Radial Insertion
C: Chip

Resistance

Part No.	Value	Part No.	Value
R001	10K	R101	10K
R002	10K	R102	10K
R003	10K	R103	10K
R004	10K	R104	10K
R005	10K	R105	10K
R006	10K	R106	10K
R007	10K	R107	10K
R008	10K	R108	10K
R009	10K	R109	10K
R010	10K	R110	10K
R011	10K	R111	10K
R012	10K	R112	10K
R013	10K	R113	10K
R014	10K	R114	10K
R015	10K	R115	10K
R016	10K	R116	10K
R017	10K	R117	10K
R018	10K	R118	10K
R019	10K	R119	10K
R020	10K	R120	10K
R021	10K	R121	10K
R022	10K	R122	10K
R023	10K	R123	10K
R024	10K	R124	10K
R025	10K	R125	10K
R026	10K	R126	10K
R027	10K	R127	10K
R028	10K	R128	10K
R029	10K	R129	10K
R030	10K	R130	10K
R031	10K	R131	10K
R032	10K	R132	10K
R033	10K	R133	10K
R034	10K	R134	10K
R035	10K	R135	10K
R036	10K	R136	10K
R037	10K	R137	10K
R038	10K	R138	10K
R039	10K	R139	10K
R040	10K	R140	10K
R041	10K	R141	10K
R042	10K	R142	10K
R043	10K	R143	10K
R044	10K	R144	10K
R045	10K	R145	10K
R046	10K	R146	10K
R047	10K	R147	10K
R048	10K	R148	10K
R049	10K	R149	10K
R050	10K	R150	10K
R051	10K	R151	10K
R052	10K	R152	10K
R053	10K	R153	10K
R054	10K	R154	10K
R055	10K	R155	10K
R056	10K	R156	10K
R057	10K	R157	10K
R058	10K	R158	10K
R059	10K	R159	10K
R060	10K	R160	10K
R061	10K	R161	10K
R062	10K	R162	10K
R063	10K	R163	10K
R064	10K	R164	10K
R065	10K	R165	10K
R066	10K	R166	10K
R067	10K	R167	10K
R068	10K	R168	10K
R069	10K	R169	10K
R070	10K	R170	10K
R071	10K	R171	10K
R072	10K	R172	10K
R073	10K	R173	10K
R074	10K	R174	10K
R075	10K	R175	10K
R076	10K	R176	10K
R077	10K	R177	10K
R078	10K	R178	10K
R079	10K	R179	10K
R080	10K	R180	10K
R081	10K	R181	10K
R082	10K	R182	10K
R083	10K	R183	10K
R084	10K	R184	10K
R085	10K	R185	10K
R086	10K	R186	10K
R087	10K	R187	10K
R088	10K	R188	10K
R089	10K	R189	10K
R090	10K	R190	10K
R091	10K	R191	10K
R092	10K	R192	10K
R093	10K	R193	10K
R094	10K	R194	10K
R095	10K	R195	10K
R096	10K	R196	10K
R097	10K	R197	10K
R098	10K	R198	10K
R099	10K	R199	10K
R100	10K	R200	10K

Resistance

Part No.	Value	Part No.	Value
R201	10K	R301	10K
R202	10K	R302	10K
R203	10K	R303	10K
R204	10K	R304	10K
R205	10K	R305	10K
R206	10K	R306	10K
R207	10K	R307	10K
R208	10K	R308	10K
R209	10K	R309	10K
R210	10K	R310	10K
R211	10K	R311	10K
R212	10K	R312	10K
R213	10K	R313	10K
R214	10K	R314	10K
R215	10K	R315	10K
R216	10K	R316	10K
R217	10K	R317	10K
R218	10K	R318	10K
R219	10K	R319	10K
R220	10K	R320	10K
R221	10K	R321	10K
R222	10K	R322	10K
R223	10K	R323	10K
R224	10K	R324	10K
R225	10K	R325	10K
R226	10K	R326	10K
R227	10K	R327	10K
R228	10K	R328	10K
R229	10K	R329	10K
R230	10K	R330	10K
R231	10K	R331	10K
R232	10K	R332	10K
R233	10K	R333	10K
R234	10K	R334	10K
R235	10K	R335	10K
R236	10K	R336	10K
R237	10K	R337	10K
R238	10K	R338	10K
R239	10K	R339	10K
R240	10K	R340	10K
R241	10K	R341	10K
R242	10K	R342	10K
R243	10K	R343	10K
R244	10K	R344	10K
R245	10K	R345	10K
R246	10K	R346	10K
R247	10K	R347	10K
R248	10K	R348	10K
R249	10K	R349	10K
R250	10K	R350	10K
R251	10K	R351	10K
R252	10K	R352	10K
R253	10K	R353	10K
R254	10K	R354	10K
R255	10K	R355	10K
R256	10K	R356	10K
R257	10K	R357	10K
R258	10K	R358	10K
R259	10K	R359	10K
R260	10K	R360	10K
R261	10K	R361	10K
R262	10K	R362	10K
R263	10K	R363	10K
R264	10K	R364	10K
R265	10K	R365	10K
R266	10K	R366	10K
R267	10K	R367	10K
R268	10K	R368	10K
R269	10K	R369	10K
R270	10K	R370	10K
R271	10K	R371	10K
R272	10K	R372	10K
R273	10K	R373	10K
R274	10K	R374	10K
R275	10K	R375	10K
R276	10K	R376	10K
R277	10K	R377	10K
R278	10K	R378	10K
R279	10K	R379	10K
R280	10K	R380	10K
R281	10K	R381	10K
R282	10K	R382	10K
R283	10K	R383	10K
R284	10K	R384	10K
R285	10K	R385	10K
R286	10K	R386	10K
R287	10K	R387	10K
R288	10K	R388	10K
R289	10K	R389	10K
R290	10K	R390	10K
R291	10K	R391	10K
R292	10K	R392	10K
R293	10K	R393	10K
R294	10K	R394	10K
R295	10K	R395	10K
R296	10K	R396	10K
R297	10K	R397	10K
R298	10K	R398	10K
R299	10K	R399	10K
R300	10K	R400	10K

Resistance

Part No.	Value	Part No.	Value
R401	10K	R501	10K
R402	10K	R502	10K
R403	10K	R503	10K
R404	10K	R504	10K
R405	10K	R505	10K
R406	10K	R506	10K
R407	10K	R507	10K
R408	10K	R508	10K
R409	10K	R509	10K
R410	10K	R510	10K
R411	10K	R511	10K
R412	10K	R512	10K
R413	10K	R513	10K
R414	10K	R514	10K
R415	10K	R515	10K
R416	10K	R516	10K
R417	10K	R517	10K
R418	10K	R518	10K
R419	10K	R519	10K
R420	10K	R520	10K
R421	10K	R521	10K
R422	10K	R522	10K
R423	10K	R523	10K
R424	10K	R524	10K
R425	10K	R525	10K
R426	10K	R526	10K
R427	10K	R527	10K
R428	10K	R528	10K
R429	10K	R529	10K
R430	10K	R530	10K
R431	10K	R531	10K
R432	10K	R532	10K
R433	10K	R533	10K
R434	10K	R534	10K
R435	10K	R535	10K
R436	10K	R536	10K
R437	10K	R537	10K
R438	10K	R538	10K
R439	10K	R539	10K
R440	10K	R540	10K
R441	10K	R541	10K
R442	10K	R542	10K
R443	10K	R543	10K
R444	10K	R544	10K
R445	10K	R545	10K
R446	10K	R546	10K
R447	10K	R547	10K
R448	10K	R548	10K
R449	10K	R549	10K
R450	10K	R550	10K
R451	10K	R551	10K
R452	10K	R552	10K
R453	10K	R553	10K
R454	10K	R554	10K
R455	10K	R555	10K
R456	10K	R556	10K
R457	10K	R557	10K
R458	10K	R558	10K
R459	10K	R559	10K
R460	10K	R560	10K
R461	10K	R561	10K
R462	10K	R562	10K
R463	10K	R563	10K
R464	10K	R564	10K
R465	10K	R565	10K
R466	10K	R566	10K
R467	10K	R567	10K
R468	10K	R568	10K
R469	10K	R569	10K
R470	10K	R570	10K
R471	10K	R571	10K
R472	10K	R572	10K
R473	10K	R573	10K
R474	10K	R574	10K
R475	10K	R575	10K
R476	10K	R576	10K
R477	10K	R577	10K
R478	10K	R578	10K
R479	10K	R579	10K
R480	10K	R580	10K
R481	10K	R581	10K
R482	10K	R582	10K
R483	10K	R583	10K
R484	10K	R584	10K
R485	10K	R585	10K
R486	10K	R586	10K
R487	10K	R587	10K
R488	10K	R588	10K
R489	10K	R589	10K
R490	10K	R590	10K
R491	10K	R591	10K
R492	10K	R592	10K
R493	10K	R593	10K
R494	10K	R594	10K
R495	10K	R595	10K
R496	10K	R596	10K
R497	10K	R597	10K
R498	10K	R598	10K
R499	10K	R599	10K
R500	10K	R600	10K

Capacitor

Part No.	Value	Part No.	Value
C001	100n	C101	100n
C002	100n	C102	100n
C003	100n	C103	100n
C004	100n	C104	100n
C005	100n	C105	100n
C006	100n	C106	100n
C007	100n	C107	100n
C008	100n	C108	100n
C009	100n	C109	100n
C010	100n	C110	100n
C011	100n	C111	100n
C012	100n	C112	100n
C013	100n	C113	100n
C014	100n	C114	100n
C015	100n	C115	100n
C016	100n	C116	

BLOCK DIAGRAM

MODEL RAK-18/25/35/50PEB

RAK-25/35/50PEBC

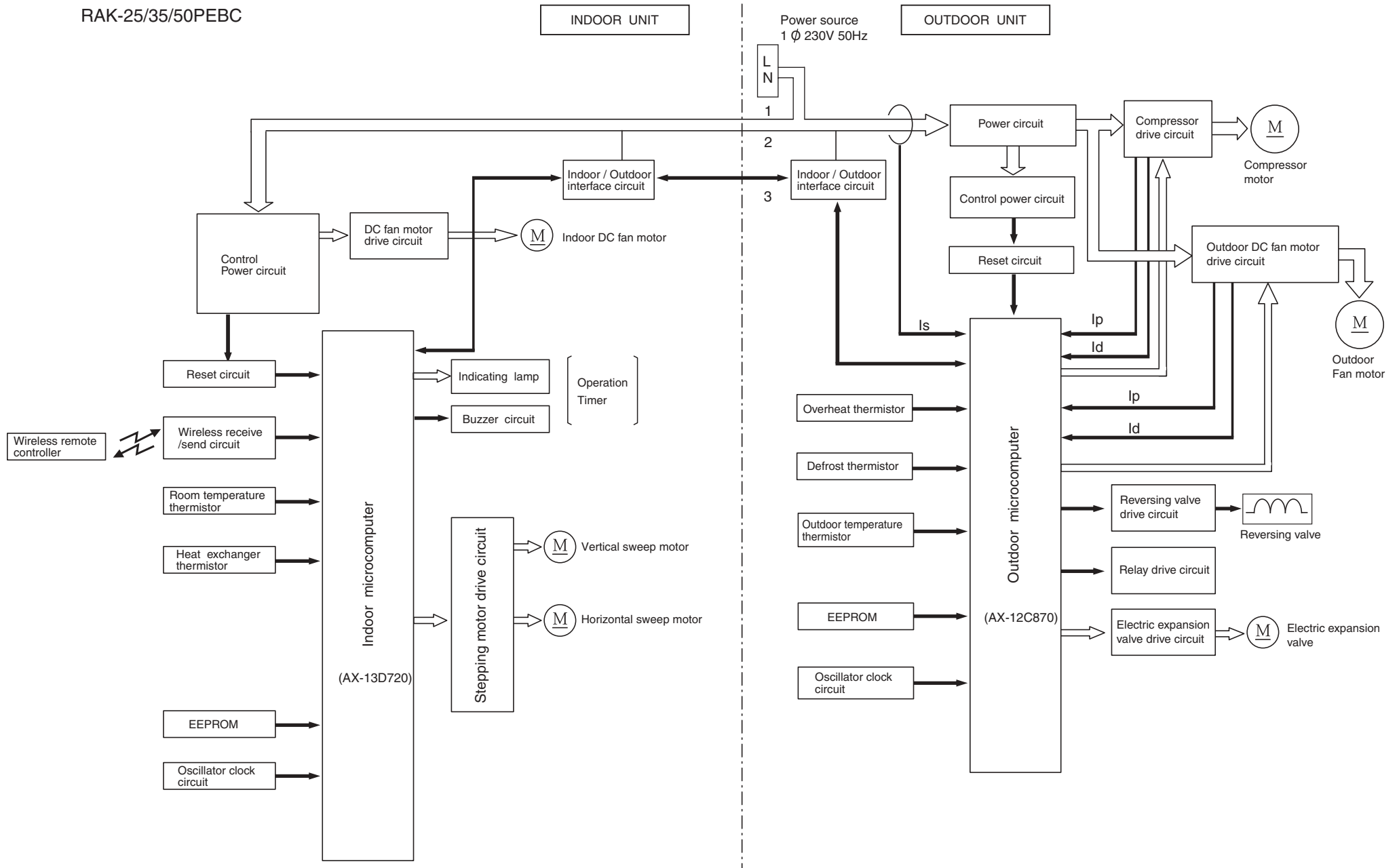

BASIC MODE

MODEL RAK-18/25/35/50PEB
RAK-25/35/50PEBC

Operation mode		Cooling	Dehumidifying	Heating
Basic operation of start/stop button				
Timer functions	Off-timer			
	On-timer			
	Off -> On On -> Off timer			
Fan speed mode (indoor fan)	Auto	<p>Changes from "Hi" to "Med" or "Lo" depending on room temperature.</p> <ol style="list-style-type: none"> Runs at "Hi" until room temperature reaches to "setting temperature-SFTDSC" after operation is started. Runs at "ultra-Lo" when thermo is off. <p>(Compressor stopped forcibly for 3 minutes)</p>		<p>Set to "ultra-Lo", "Silent", "Lo", "Med", "Hi", "ultra-Hi" or "stop" depending on the room temperature, time and heat exchanger temperature. Set to "stop" if the heat exchanger temperature is "DNZKOF" during Thermo OFF. (When reach at "DNZKON", fan speed set to "ultra-Lo" again.)</p> <p>In modes other than left</p> <p>When the compressor is running at maximum speed during hot-dash or when recovered from defrosting:</p> <p>90° Fan speed UP/DOWN delay time</p>
	Hi	<p>Set to "ultra-Hi" when the compressor runs at cold dash mode speed, and to "Hi" in other modes. Runs at "ultra-Lo" when thermo is off. (Only for Caribbean area: Runs at "Hi" when thermo is off.)</p>		<p>Set to "ultra-Lo", "Silent", "Lo", "Med", "Hi", "ultra-Hi" or "stop" depending on the room temperature, time and heat exchanger temperature. Set to "stop" if the heat exchanger temperature is "DNZKOF" during Thermo OFF. (When reach at "DNZKON", fan speed set to "ultra-Lo" again.)</p> <p>Set to "ultra-Hi" when the compressor is running at maximum speed during hot dash or when recovered from defrosting.</p>
	Med	<p>Operates at "Med" regardless of the room temperature. Runs at "ultra-Lo" when thermo is off. (Only for Caribbean area: Runs at "Med" when thermo is off.)</p>		<p>Set to "ultra-Lo", "Silent", "Lo", "Med", "Hi", "ultra-Hi" or "stop" depending on the room temperature, time and heat exchanger temperature. Set to "stop" if the heat exchanger temperature is "DNZKOF" during Thermo OFF. (When reach at "DNZKON", fan speed set to "ultra-Lo" again.)</p>
	Lo	<p>Operates at "Lo" regardless of the room temperature. Runs at "ultra-Lo" when thermo is off. (Only for Caribbean area: Runs at "Lo" when thermo is off.)</p>	Set to "Lo" in modes other than when the compressor stops.	<p>Set to "ultra-Lo", "Silent", "Lo", "Med", "Hi", "ultra-Hi" or "stop" depending on the room temperature, time and heat exchanger temperature. Set to "stop" if the heat exchanger temperature is "DNZKOF" during Thermo OFF. (When reach at "DNZKON", fan speed set to "ultra-Lo" again.) The fan speed is controlled by the heat exchanger temperature; the overload control is executed as in the following diagram:</p>
	Silent	<p>Operates at "Silent" regardless of the room temperature. Runs at "ultra-Lo" when thermo is off. (Only for Caribbean area: Runs at "Silent" when thermo is off.)</p>	Set to "Silent" in modes other than when the compressor stops.	
	Basic operation of temperature controller	See page 30.	See page 32.	See page 34.

Table 1 Mode data file

MODEL	RAK-18PEB	RAK-25PEB RAK-25PEBC	RAK-35PEB RAK-35PEBC	RAK-50PEB RAK-50PEBC
LABEL NAME	VALUE			
WMAX	4200 min-1	6200 min-1	6700 min-1	6000 min-1
WMAX2	4200 min-1	6200 min-1	6700 min-1	6000 min-1
WSTD	3000 min-1	4500 min-1	5700 min-1	4800 min-1
WJKMAX	2800 min-1	4200 min-1	5500 min-1	4100 min-1
WBEMAX	2800 min-1	3800 min-1	5000 min-1	3500 min-1
WSZMAX	2800 min-1	3700 min-1	4000 min-1	3500 min-1
CMAX	4600 min-1	4600 min-1	6000 min-1	5500 min-1
CMAX2	4600 min-1	4600 min-1	6000 min-1	6000 min-1
CSTD	3200 min-1	3200 min-1	4600 min-1	4750 min-1
CJKMAX	3000 min-1	3000 min-1	4400 min-1	4100 min-1
CBEMAX	2800 min-1	2800 min-1	3800 min-1	3000 min-1
CSZMAX	2200 min-1	2200 min-1	3500 min-1	3000 min-1
WIN-CMPH	2000 min-1	2000 min-1	2000 min-1	1800 min-1
WIN-CMPL	2000 min-1	2000 min-1	2000 min-1	1800 min-1
CMIN	2000 min-1	2000 min-1	2000 min-1	1800 min-1
STARTMC	90 Seconds	90 Seconds	90 Seconds	90 Seconds
DWNRATEW	80%	80%	80%	80%
DWNRATEC	60%	60%	60%	70%
SHIFTW	1.00 °C	1.00 °C	1.00 °C	1.00 °C
SHIFTC	0.00 °C	0.00 °C	0.00 °C	1.33 °C
CLMXT	30.00 °C	30.00 °C	30.00 °C	30.00 °C
TEION	2.00 °C	2.00 °C	2.00 °C	4.00 °C
TEIOF	6.00 °C	6.00 °C	6.00 °C	9.00 °C
SFTDSW	1.00 °C	1.00 °C	0.66 °C	0.66 °C
DFTIM-OTP0	43 Minutes	43 Minutes	43 Minutes	43 Minutes
DFTIM-OTP5	43 Minutes	43 Minutes	43 Minutes	43 Minutes
DFTIM-OTP10	43 Minutes	43 Minutes	43 Minutes	43 Minutes
FCAUT-L	0.66 °C	0.66 °C	0.66 °C	0.66 °C
FCAUT-H	2.00 °C	2.00 °C	2.00 °C	2.00 °C
SFTDSC	0.66 °C	0.66 °C	0.66 °C	0.66 °C
OFTMPC	1.00 °C	1.00 °C	1.00 °C	1.00 °C
DASUPHH	43.00	45.00	45.00	39.00
DASDNHH	39.00	41.00	41.00	36.00
DASUPH	38.00	40.00	40.00	35.00
DASDNH	33.33	35.33	35.33	32.00
DASUPL	33.00	35.00	35.00	31.00
DASDNL	28.00	28.00	28.00	29.00
DASUPS	28.00	28.00	28.00	28.00
DASDNS	27.00	27.00	27.00	26.00
NORUPH	45.00	45.00	45.00	45.00
NORDNH	36.00	40.00	40.00	38.00
NORUPL	36.00	37.00	37.00	37.00
NORDNL	33.00	33.00	33.00	33.66
NORUPS	33.00	33.00	33.00	33.00
NORDNS	30.00	30.00	30.00	30.00
PDCIN2	50.00	50.00	54.00	50.00
PDCOF2	45.00	45.00	48.00	48.00
DNZKON	15.00	15.00	15.00	15.00
DNZKOF	13.00	13.00	13.00	13.00
FNUPPW-C	30 min-1	30 min-1	30 min-1	30 min-1
DFMAX-STD	5500 min-1	5500 min-1	5500 min-1	4000 min-1
DFMAX-ATF	5500 min-1	5500 min-1	5500 min-1	4000 min-1

Basic Cooling Operation

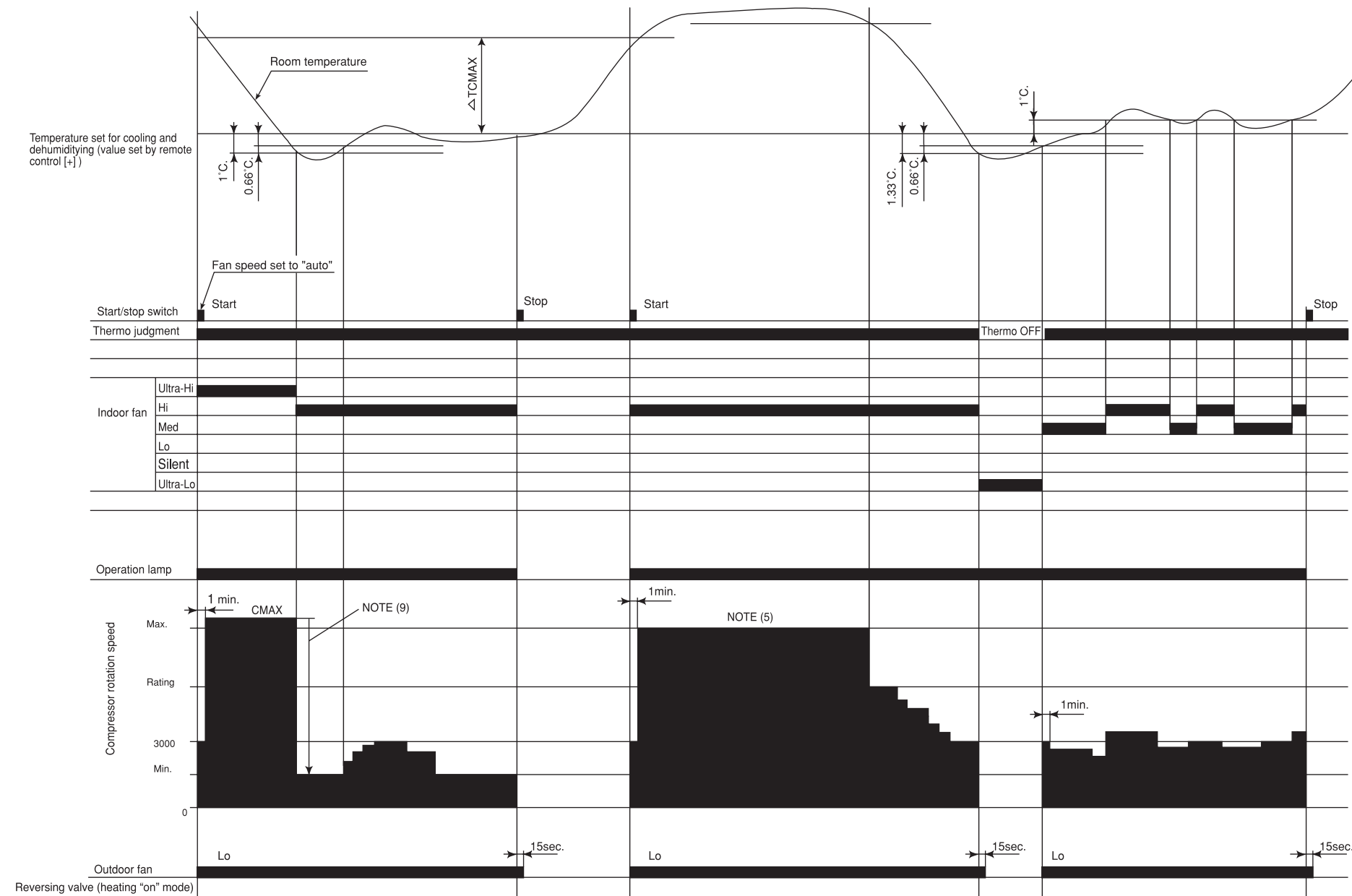

Notes:

- (1) Condition for entering into Cool Dashed mode. When fan set to "Hi" or "Auto" and when the compressor speed (P section) due to temperature difference between setting temperature (including the correction shift only) and room temperature is C_{MAX} or higher.
- (2) Cool Dashed will release when i) a maximum 25 minutes is lapsed and ii) room temperature is lower than set temperature -3°C (thermo off) and iii) when room temperature has achieved setting temperature -1°C then maximum Cool Dashed time will be revised to 20 minutes. And iv) indoor fan is set to Lo and Med fan mode and v) change operation mode.
- (3) During Cool Dashed operation, thermo off temperature is set temperature (with shift value) -3°C . After thermo off, operation continue in Fuzzy control mode.
- (4) Compressor minimum "ON" time and "OFF" time is 3 minutes.
- (5) During normal cooling mode, compressor maximum rpm C_{MAX} will maintain for 60 minutes if indoor temperature is lower than CLM_{XTP}. No time constrain if indoor temperature is higher than CLM_{XTP}.
- (6) When fan is set to "Hi", compressor rpm will be limited to C_{STD}.
- (7) When fan is set to "Med", compressor rpm will be limited to C_{JKMAX}.
- (8) When fan is set to "Lo", compressor rpm will be limited to C_{BEMAX}.
- (9) During Cool Dashed, when room temperature reaches set temperature -1°C compressor rpm is actual rpm x D_{WNRATEC}.

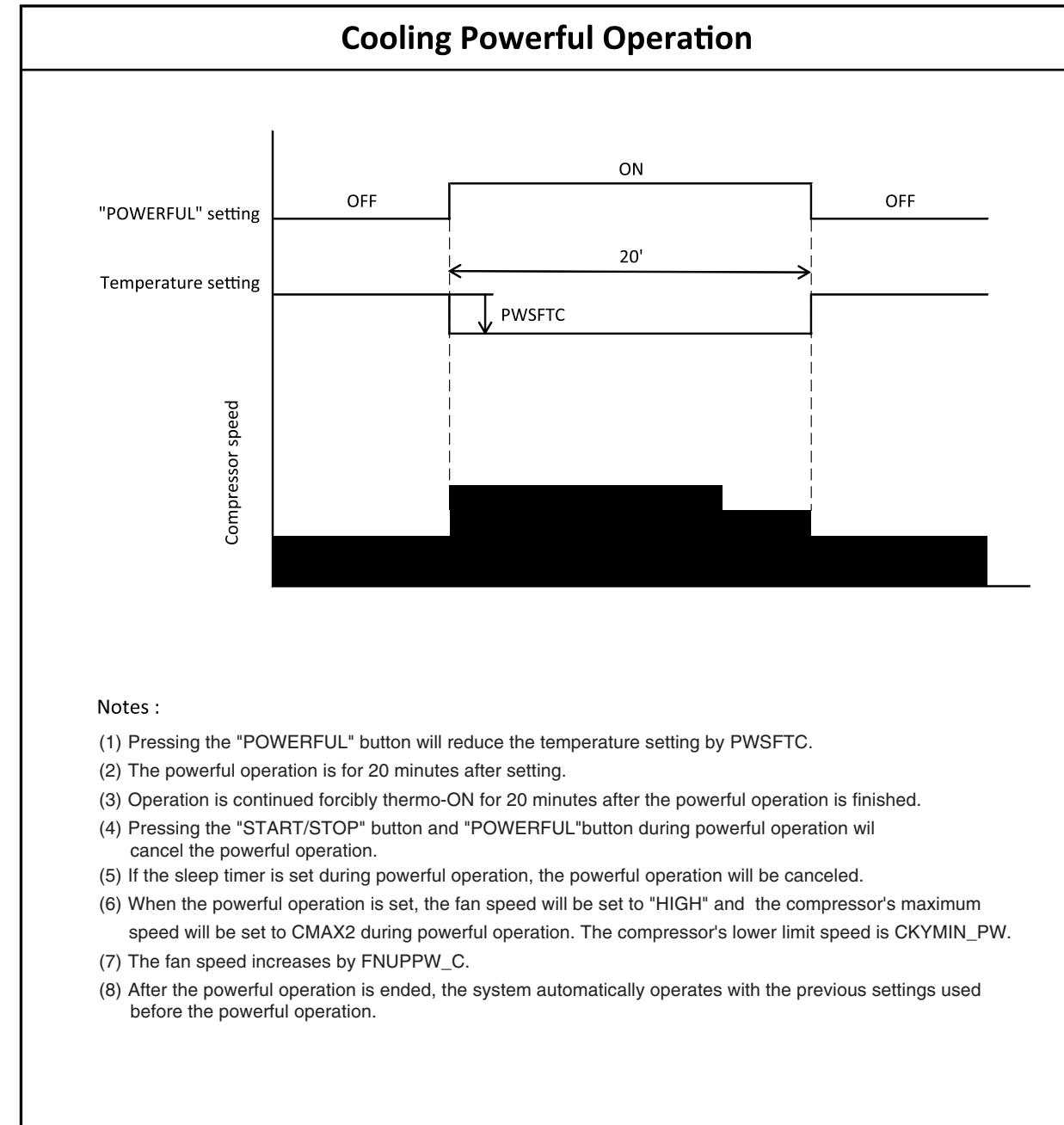
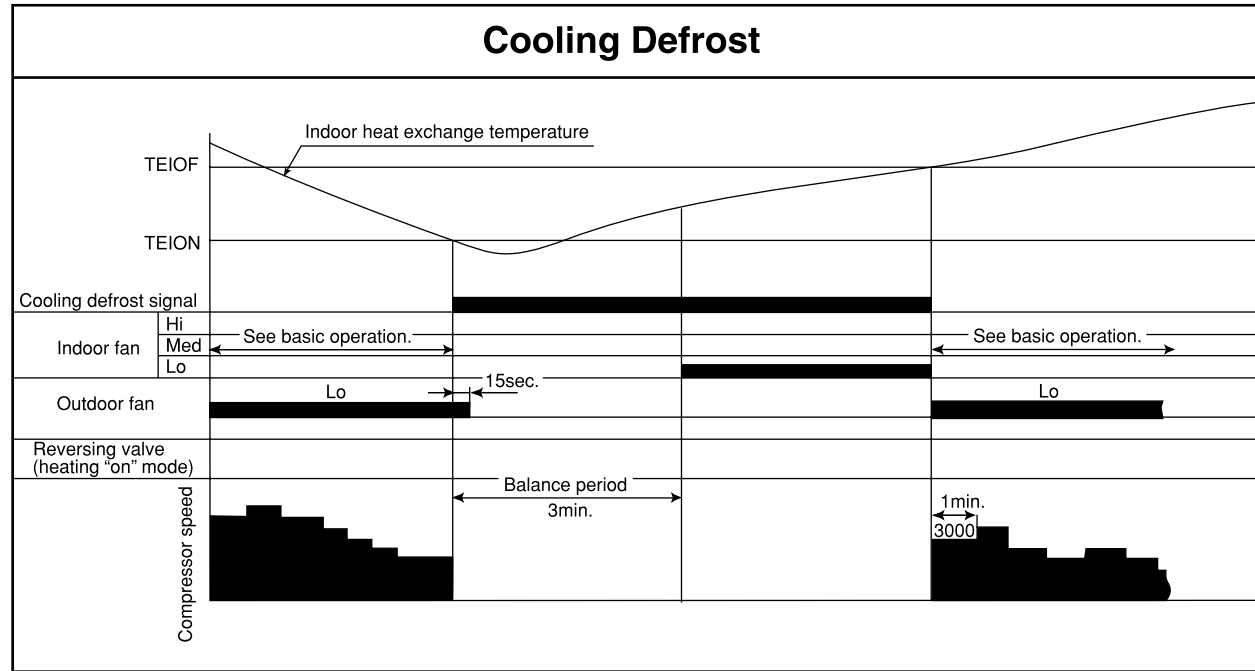

Notes :

- (1) Pressing the "POWERFUL" button will reduce the temperature setting by PWSFTC.
- (2) The powerful operation is for 20 minutes after setting.
- (3) Operation is continued forcibly thermo-ON for 20 minutes after the powerful operation is finished.
- (4) Pressing the "START/STOP" button and "POWERFUL" button during powerful operation will cancel the powerful operation.
- (5) If the sleep timer is set during powerful operation, the powerful operation will be canceled.
- (6) When the powerful operation is set, the fan speed will be set to "HIGH" and the compressor's maximum speed will be set to CMAX2 during powerful operation. The compressor's lower limit speed is CKYMIN_PW.
- (7) The fan speed increases by FNUPPW_C.
- (8) After the powerful operation is ended, the system automatically operates with the previous settings used before the powerful operation.

Dehumidifying

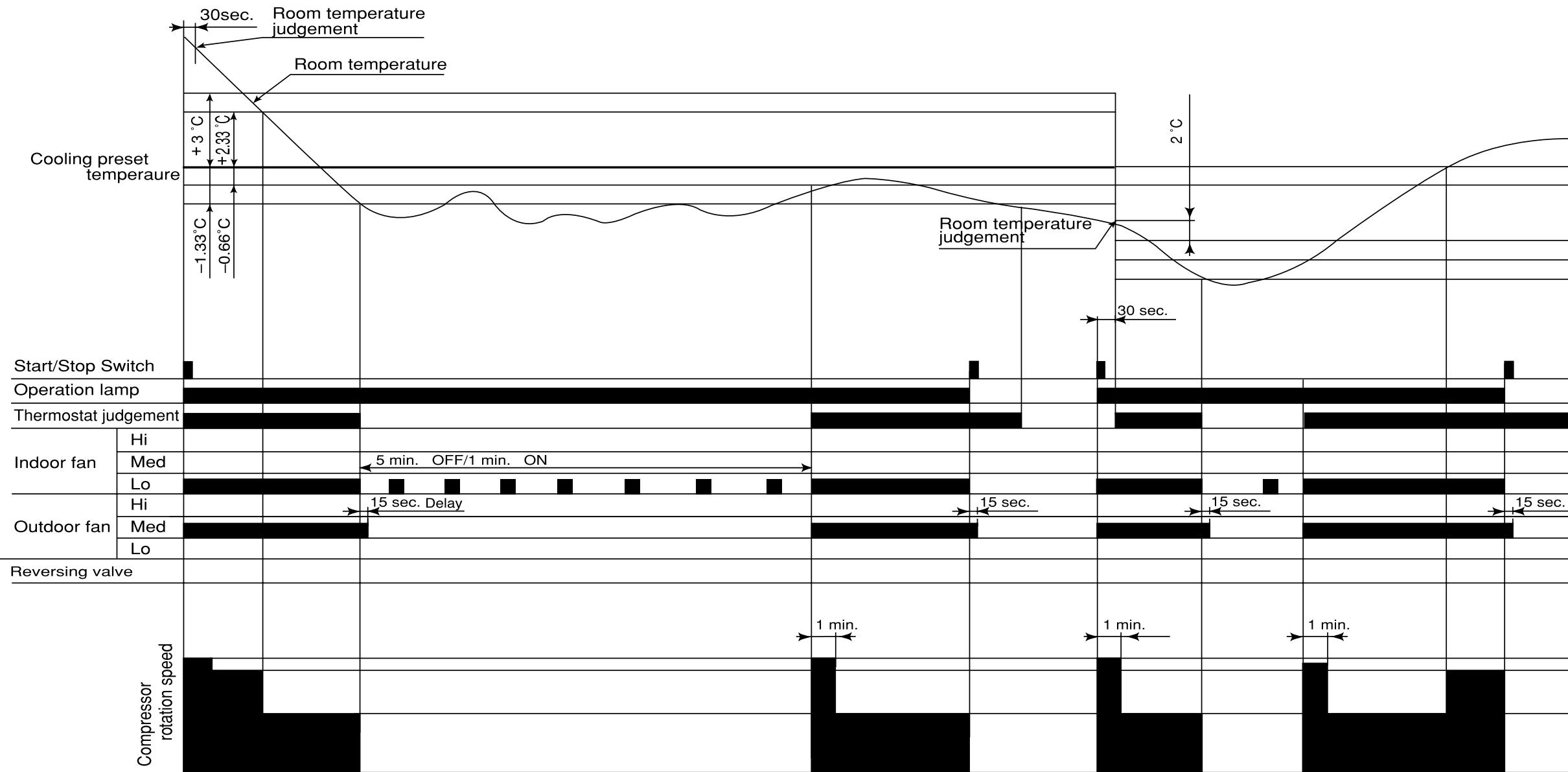

Notes:

- (1) If the room temperature is (cooling preset temperature) - (1.33°C) or less after 30 seconds from starting the operation, the operation is done assuming as the preset temperature = (room temperature at the time) - (2°C).
- (2) The indoor fan is operated in the "Lo" mode. During thermo OFF indoor fan will be OFF for 5 minutes and ON for 1 minute.
- (3) When the operation is started by the thermostat turning ON, the start of the indoor fan is delayed 32 seconds after the start of compressor operation.
- (4) The compressor is operated forcedly for 3 minutes after operation is started.
- (5) The minimum ON time and OFF time of the compressor are 3 minutes.

Dehumidifying Powerful Operation

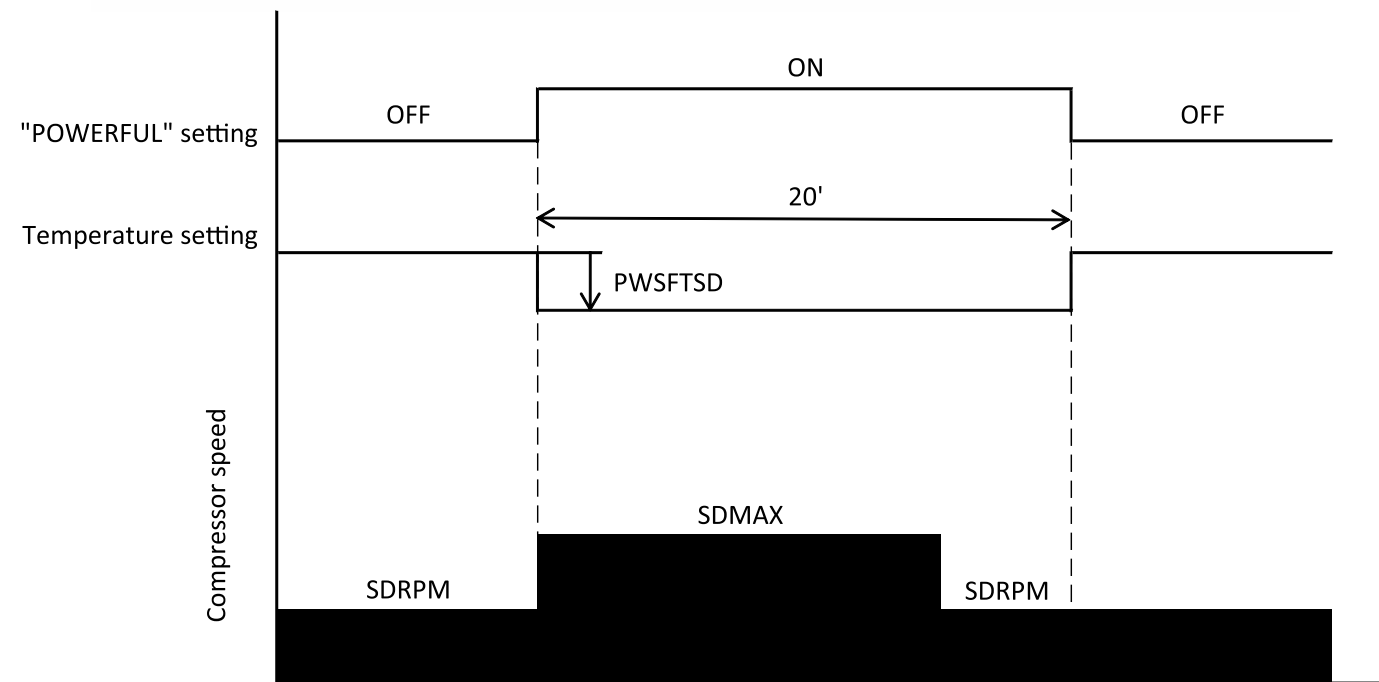

Notes :

- (1) Pressing the "POWERFUL" button will reduce the temperature setting by PWSFTSD.
- (2) The powerful operation is for 20 minutes after setting.
- (3) Operation is continued forcibly thermo-ON for 20 minutes after the powerful operation is finished.
- (4) Pressing the "START/STOP" button and "POWERFUL" button during powerful operation will cancel the powerful operation.
- (5) If the sleep timer is set during powerful operation, the powerful operation will be canceled.
- (6) If the differential (the room temperature - the temperature setting) is "the differential ≥ 3 °C" after powerful setting, the compressor's maximum speed during powerful operation will be set to SDMAX. Then the differential reduce "the differential ≤ 2.33 °C" during powerful operation, the compressor's speed will be set to SDRPM.
If the differential (the room temperature - the temperature setting) is "the differential < 3 °C" after powerful setting, the compressor's minimum speed during powerful operation will be set to SDRPM.
- (7) After the powerful operation is ended, the system automatically operates with the previous settings used before the powerful operation.

Basic Heating Operation

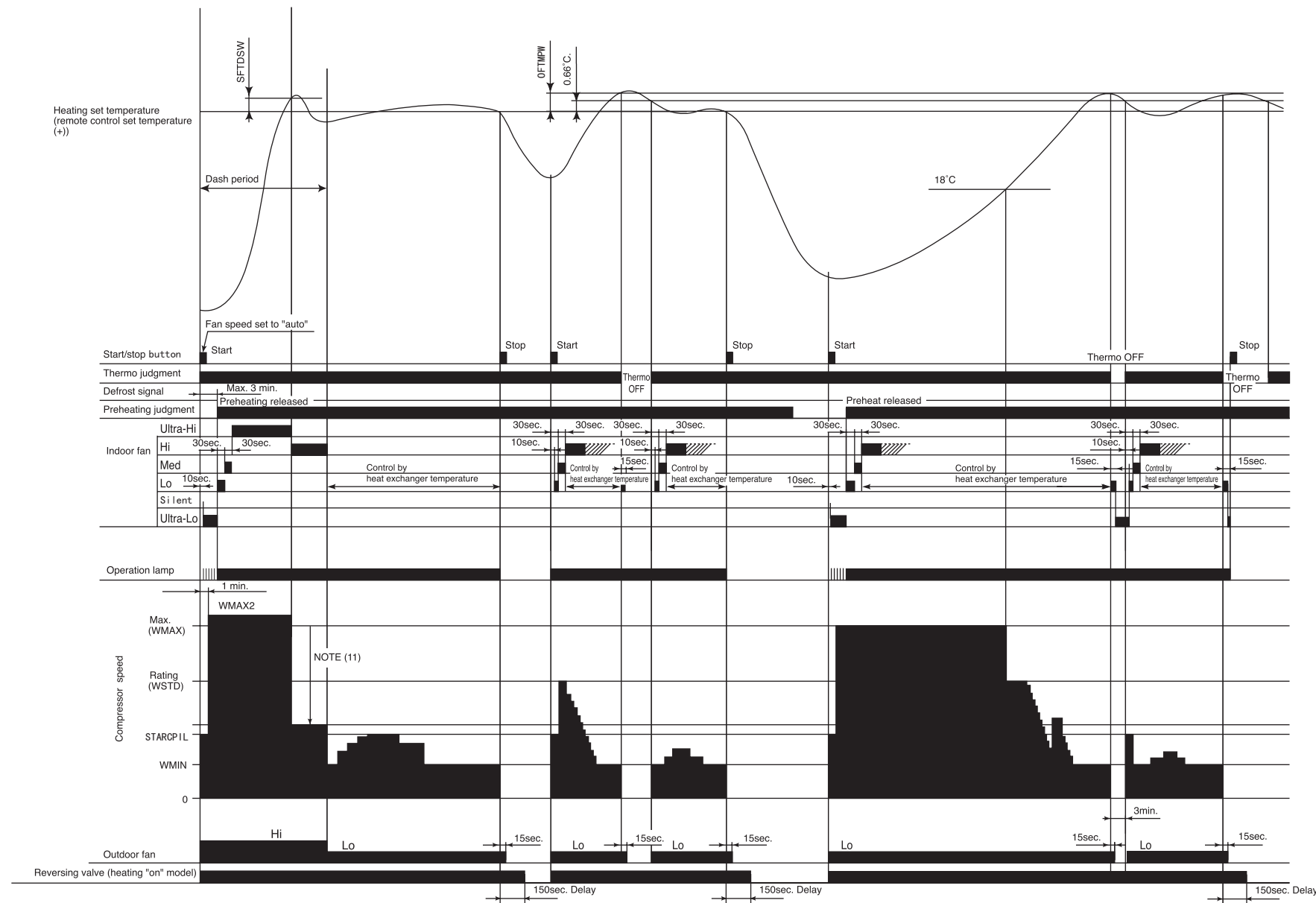

Notes:

- (1) Condition for entering into hot dashed mode. When fan set to "Hi" or "Auto" and i) room temperature is 18 or less, and ii) outdoor temperature is 10 or less, and iii) compressor speed (P section) due to temperature difference between setting temperature(including shift value only) and room temperature is WMAX or more.
- (2) The maximum compressor speed period during hot dash is finished when i) room temperature has reached the setting temperature + SFTDSW. ii) thermo off.
- (3) During hot dashed operation, thermo off temperature is setting temperature (with shift value) +3. After thermo off, operation continue inn Fuzzy control mode.
- (4) Minimum "ON" time and minimum "OFF" time of compressor operation is 3 minutes.
- (5) During normal heating mode, compressor maximum rpm WMAX will maintain for 120 minutes. No time limit constrain if room temperature is 18 or less and outdoor temperature is 2 or less.
- (6) During preheating or defrosting or auto fresh defrosting mode, indoor unit operation lamp will blink at interval of 2 seconds "ON" and 1 second "OFF".
- (7) When heating mode starts, it will enter into preheating mode if indoor heat exchanger temperature is less than YNEOF + 0.33.
- (8) When fan is set to "Med" or "Lo" or "Silent", compressor rpm will be limited to "WJKMAX" or "WBEMAX" or "WSZMAX".
- (9) During "Ultra-Lo" mode, if room temperature is 18 or less, indoor fan will stop. If room temperature is 18 + 0.33 or more, fan will continue in "Ultra-Lo" mode. However, "Ulrrta-Lo" mode during preheating or preheating after defrosting does not stop if room temperature is 18 or less.
- (10) During hot dashed or outdoor temperature is -5 or less, compressor rpm is WMAX2.
- (11) During hot dashed, when room temperature reaches setting temperature + SFTDSW compressor rpm is actual rpm x DWNRATEW.

Reversing valve defrosting

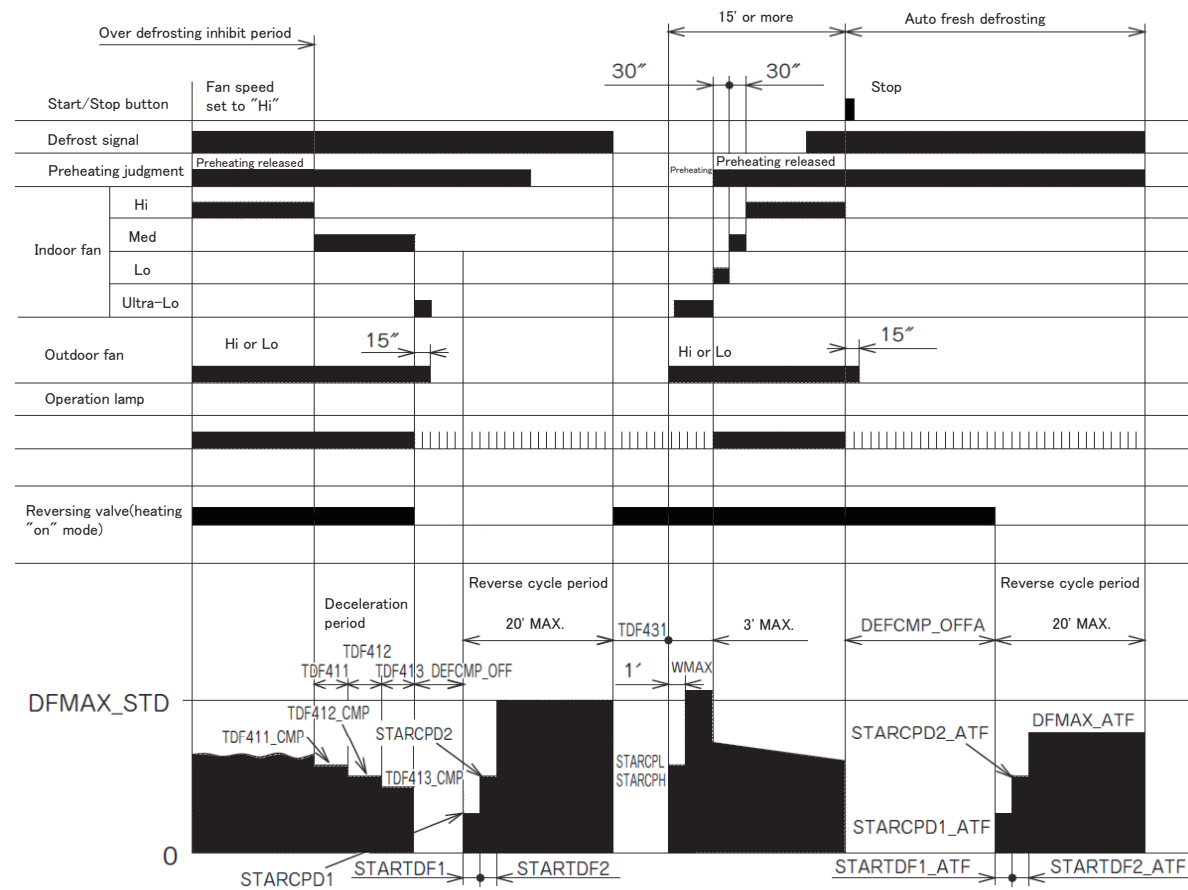

Notes:

- (1) The defrosting inhibit period is set as shown in the diagram below. When defrosting has finished once, the inhibit period is newly set, based on the outdoor temperature when the compressor was started. During this period, the defrost signal is not accepted.
- (2) If the difference between the room and outdoor temperature is large when defrosting is finished, the maximum compressor speed (WMAX) or (WMAX2) can be continued for 120 minutes maximum.
- (3) The defrosting period is 12 minutes maximum.
- (4) When operation is stopped during defrosting, it is switched to auto refresh defrosting.
- (5) Auto refresh defrosting cannot be engaged within 15 minutes after operation is started or defrosting is finished.

Setting Defrosting Inhibit Period

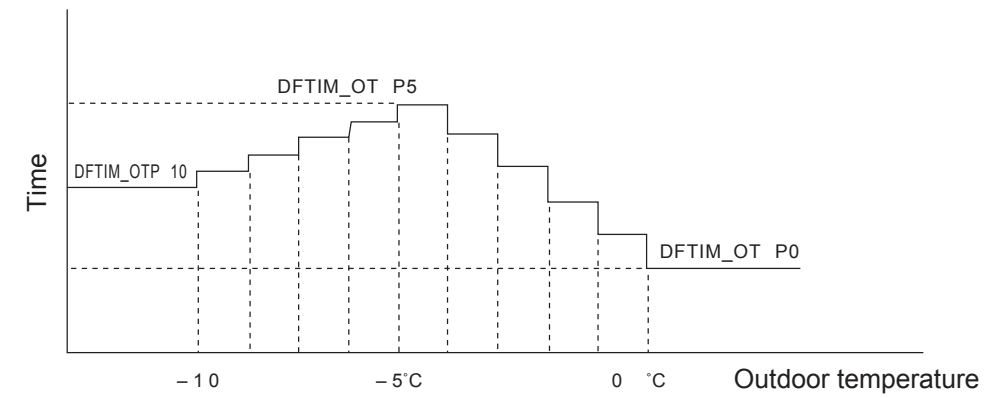

Notes:

- (1) The first inhibit time after operation start is set to DFTIM_FST.
- (2) From the second time onwards, the inhibit time is set according to the time required for defrosting.
Reverse cycle operation time \geq [DEFCOL] : DEFTIM_COL is set.
Reverse cycle operation time $<$ [DEFCOL] : The time corresponding to outdoor temperature is set.

Heating Powerful Operation

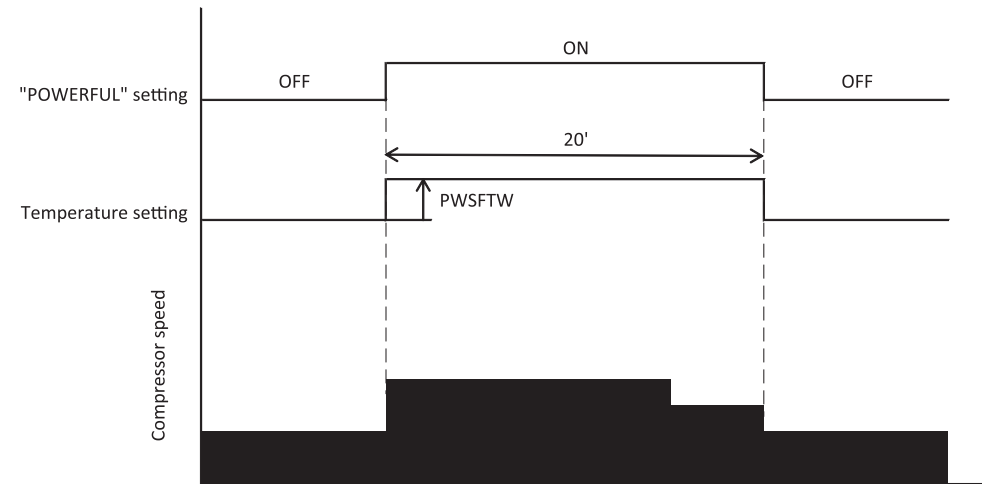

Notes :

- (1) Pressing the "POWERFUL" button will increase the temperature setting by PWSFTW.
- (2) The powerful operation is for 20 minutes after setting.
- (3) Operation is continued forcibly thermo-ON for 20 minutes after the powerful operation is finished.
- (4) Defrost is inhibited for 20 minutes after the start of the powerful operation.
- (5) Pressing the "START/STOP" button and "POWERFUL" button during powerful operation will cancel the powerful operation.
- (6) If the sleep timer is set during powerful operation, the powerful operation will be canceled.
- (7) When the powerful operation is set, the fan speed will be set to "HIGH" and the compressor's maximum speed will be set to WMAX2 during powerful operation. The compressor's lower limit speed is WKYMIN_PW.
- (8) After the powerful operation is ended, the system automatically operates with the previous settings used before the powerful operation.

Leave Home

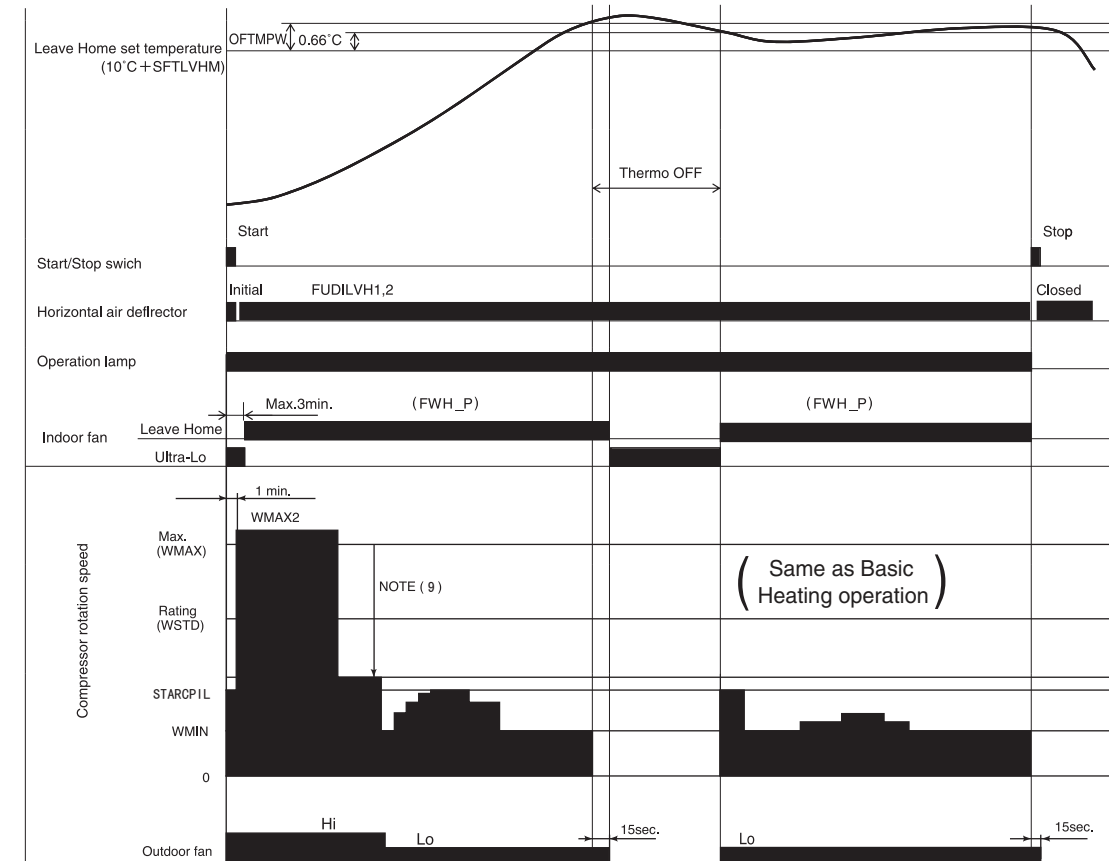

Notes:

Perform Leave Home operation according to the following control contents.

- (1) Operation mode : Heating
- (2) Setting temperature : 10°C
- (3) Shift value : + SFTLVHM
- (4) Indoor fan speed : FWH_P
- (5) Outdoor fan speed :
- (6) Compressor start control: } Same as Basic Heating operation
- (7) Compressor speed :
- (8) Operation lamp : ON

ECO

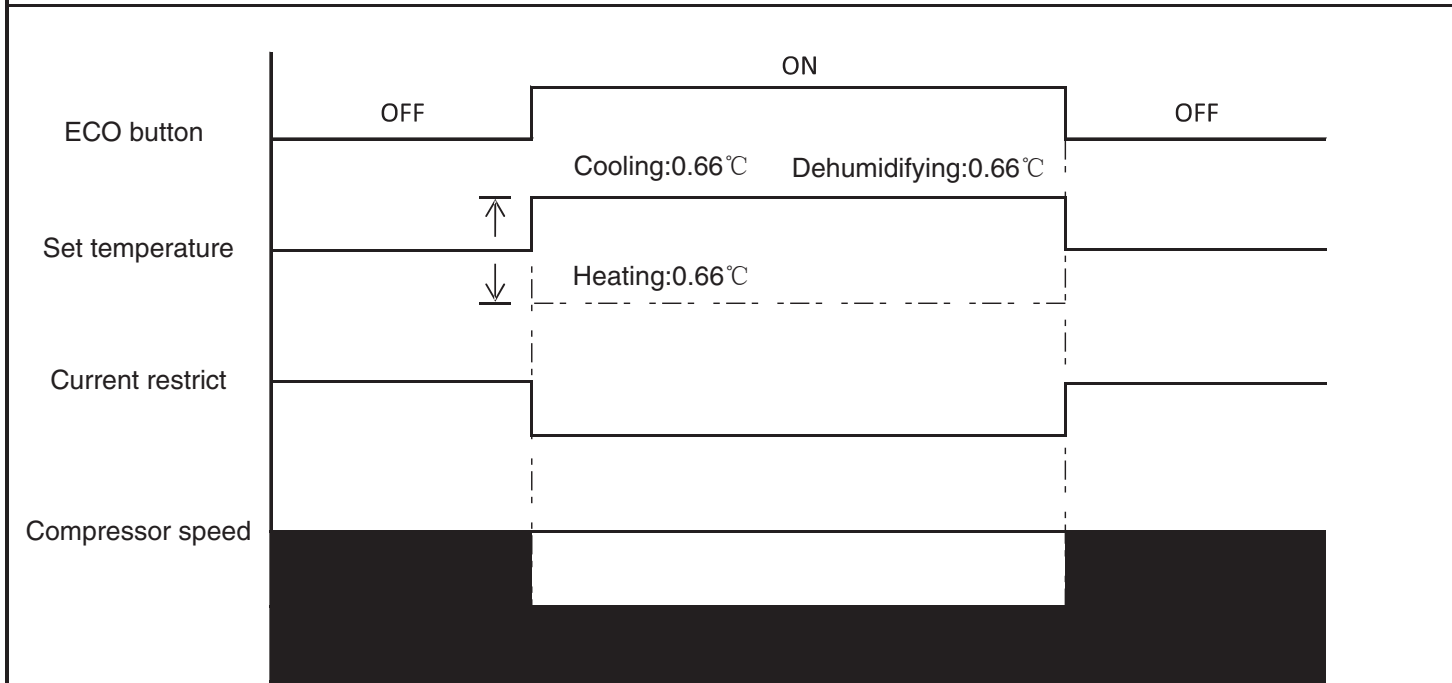

Notes:

- Can't set POWERFUL and ECO at the same time.
- During FAN operation, can't set ECO.

REFRIGERATING CYCLE DIAGRAM

MODEL RAK-18/25/35PEB
RAK-25/35PEBC
RAC-18/25/35WEB

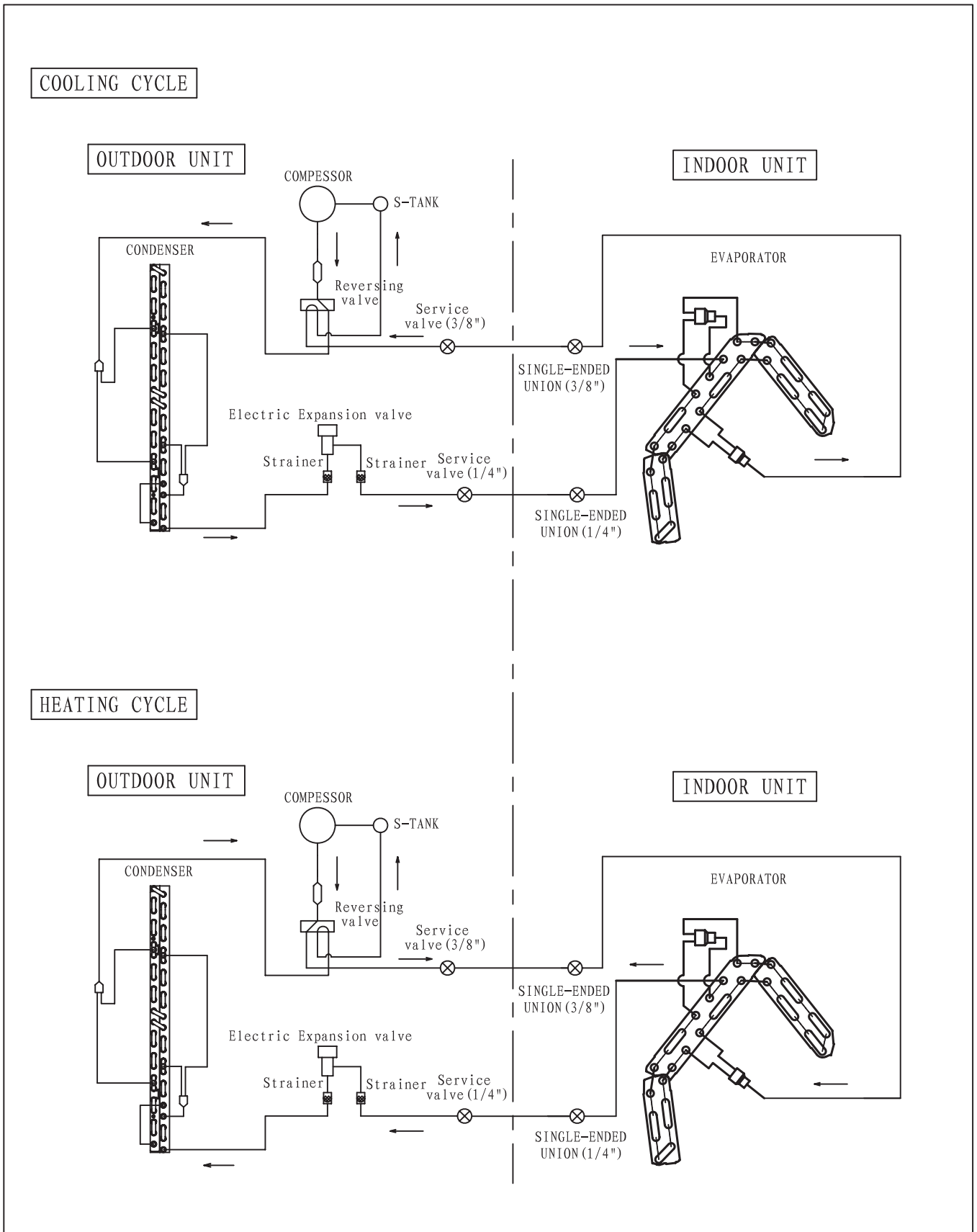

REFRIGERATING CYCLE DIAGRAM

MODEL RAK-50PEB
RAK-50PEBC
RAC-50WEB

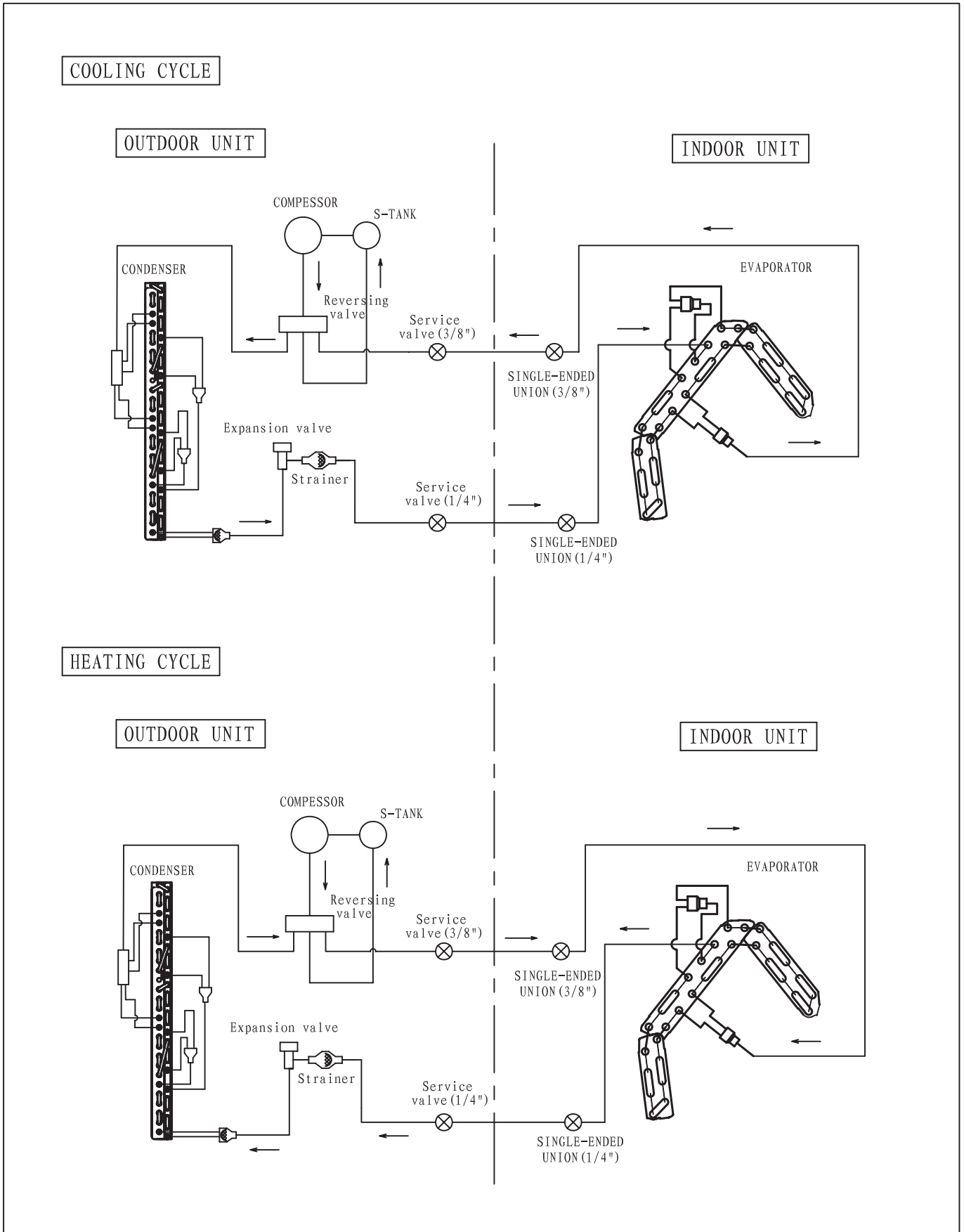

Procedure for Disassembly and Reassembly

INDOOR UNIT RAK-18/25/35/50PEB
RAK-25/35/50PEBC

1. Front Panel

Be sure to hold the front panel with both hands to detach and attach it.

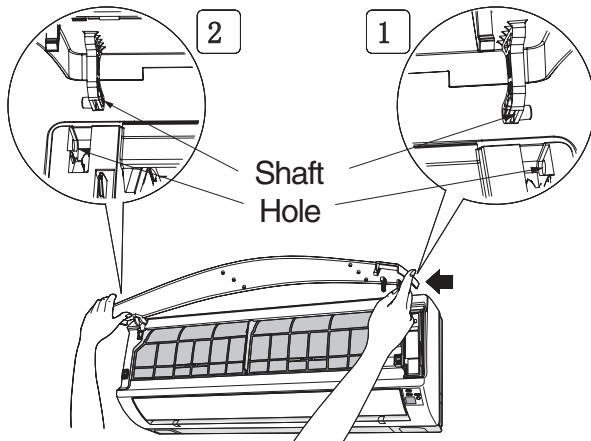

Fig. 1

When the front panel is fully opened with both hands, push the right arm to the inside to release it, and while closing the front panel slightly, put it out forward.

2. Front cover

- (1) After removing the screw of fixing the terminal cover, hold the handle of terminal cover and remove it.
- (2) After removing two screws, pull the center of the front cover forward and release the claws.
- (3) Hold the front cover at both lower sides and pull them forward to remove.

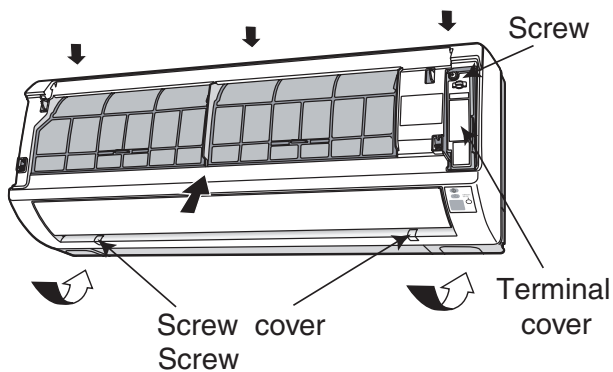

Fig. 2

3. Control P.W.B. and Indicating P.W.B.

- (1) Remove each connector from the lead wire.
- (2) Remove the four P.W.B. supports from the control P.W.B.
- (3) Pull the support hook at the upper side of the indication lamp of the indicating P.W.B. and pull out the P.W.B. forward.

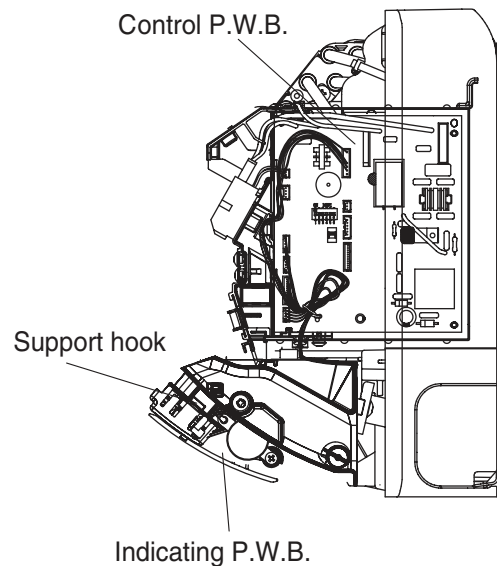

Fig. 3

4. Tangential air flow fan and fan motor

- (1) Press to lower the hook at the center of the unit a little and pull the claw forward to remove the drain pan.

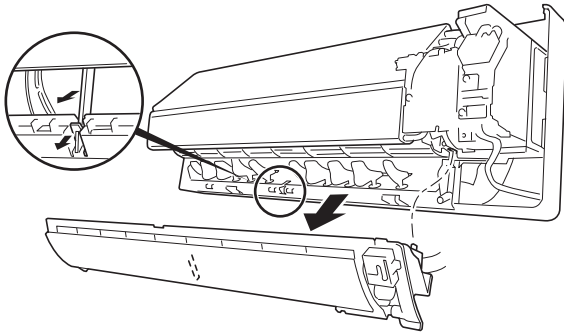

Fig. 4

- (2) Remove the screw from the upper and lower bearing covers.
- (3) Remove the locking hook of the lower bearing cover from the Cabinet.

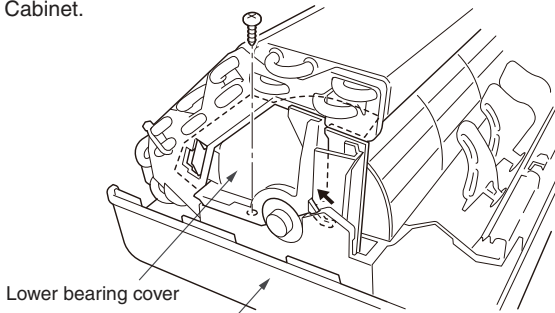

Fig. 5

- (4) Remove two lock screws from the fan motor holder
- (5) Pull up the evaporator by holding it at the lower side. Insert a screw driver through the space between the evaporator and drain chute and loosen the fan lock screw to remove the fan motor.

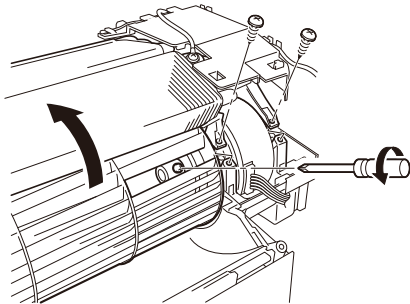

Fig. 6

<OUTDOOR UNIT> MODEL RAC-18/25/35WEB

1. Electrical Parts

- (1) Remove the upper cover fixing screws and lift the cover to remove it.
- (2) Remove the service valve cover.
- (3) Remove the terminal plate cover.
- (4) Remove the right side cover.

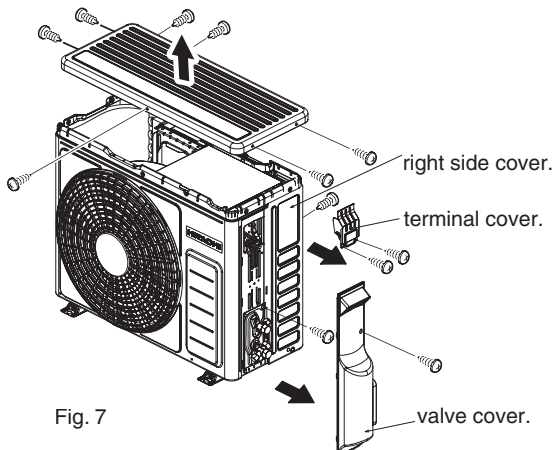

Fig. 7

- (5) Remove the electrical box fixing screws and GND wire fixing screw.

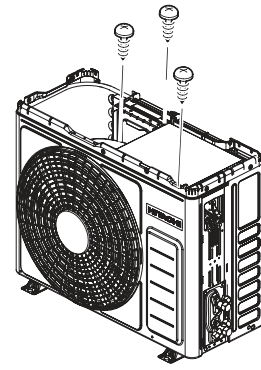

Fig. 8

- (6) Remove P lock which binds lead wires.
- (7) Set the electrical box upside down.

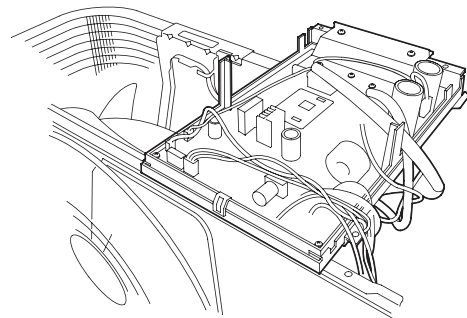

Fig. 9

- (8) Remove P.W.B. fixing screws (2 locations) and radiation fin fixing screws (7 locations), and remove the P.W.B. from the support.

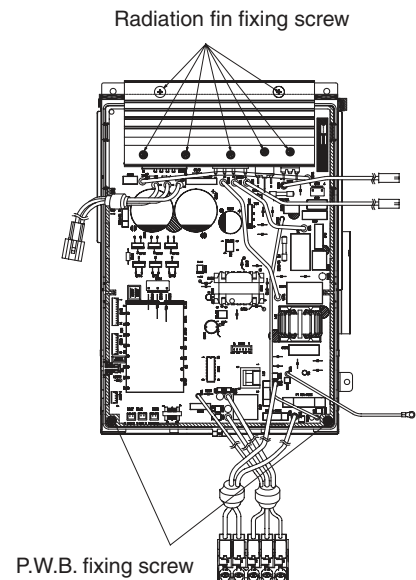

Fig. 10

OUTDOOR UNIT MODEL RAC-50WEB

1. Electrical parts

- (1) Remove the service value cover lock screws and lower the cover to remove it.
- (2) Remove the top cover lock screw and raise the cover to remove it.

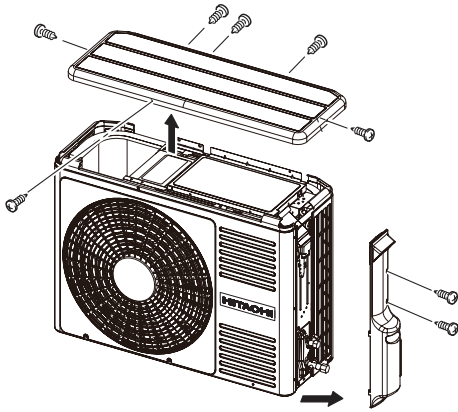

Fig. 11

- (3) Remove the front cover lock screw.
- (4) Lower the right side of the front cover and pull it forward. Then, remove the cover from the hook.
- (5) Pull the right side of the front cover a little and pull up the left side to remove it from the hook.

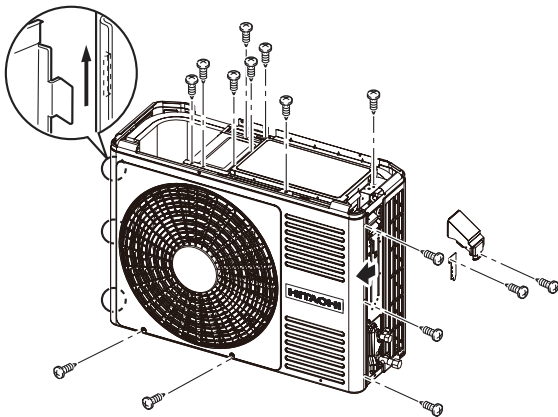

Fig. 12

- (6) Remove each connector and earth cable from the lead wire. Then, remove the electrical box.

DESCRIPTION OF MAIN CIRCUIT OPERATION

MODEL RAK-18/25/35/50PEB, RAK-25/35/50PEBC

1. Control power circuit

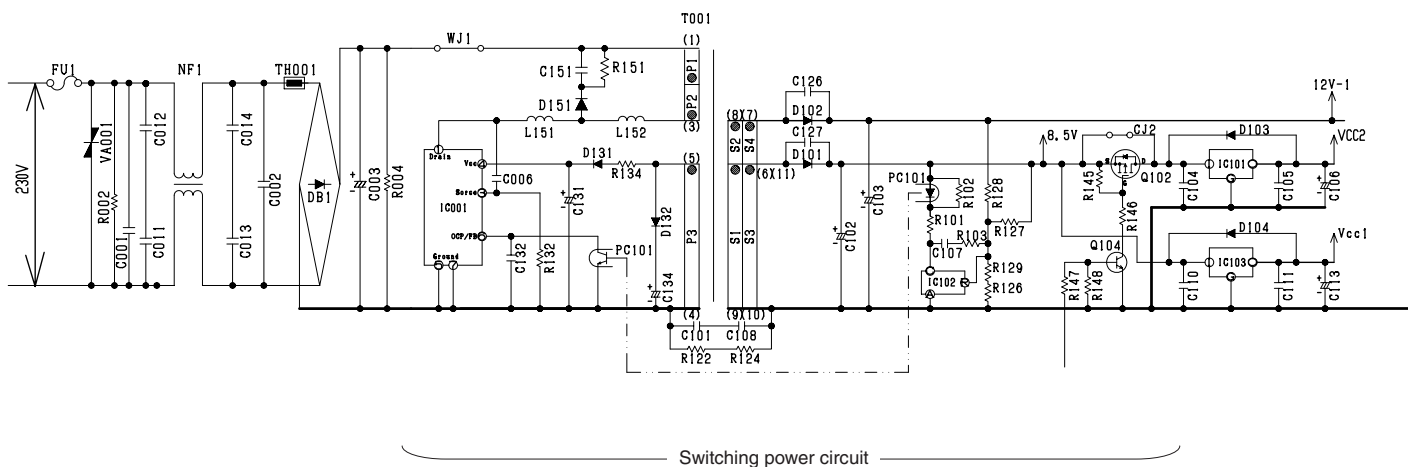

Fig. 1-1

- An AC power supply from outdoor unit passes through the 3.15 A fuse, varistor (VA001), and noise filter circuit and rectified and smoothed by DB1 and C003 to become a DC current 325 V. It is then supplied to indoor fan motor drive circuit, and switching power circuit.
- The switching power circuit, as controlled by IC001, drives the primary winding of the transformer (T001) to produce a specified voltage at the output winding. [The output terminal (pin ①) of IC001 has a switching voltage. But it changes in voltage peak and oscillation period depending on the power load. usually, the oscillation frequency when the air condition operation is about 67 kHz. In the standby state, the oscillation frequency is lowered to a level as low as 20 kHz or so to reduce the standby power.]
- The outputs of the output windings of the transformer is rectified and smoothed to become DC voltages at primary 18.5 V, 12 V, and 8.5 V respectively. The primary 18.5 V is supplied to the drive circuit of the indoor fan motor, the 12 V is supplied to each vane motor and to the drive circuits of the cleaning unit driving motor and other equipment, and the 8.5 V is adjusted to a stable 5 V by the 3-terminal regulator IC (IC101, IC103) and supplied to the microcomputer peripheral circuit.

Check

If a failure in a part or circuit has produced an abnormal current in the power supply, the 3.15 A fuse will melt down to prevent further damage. If the 3.15 A fuse melts down, check the indoor fan motor, switching electrical circuit, and other components and replace any defective part.

Check

If an abnormally high voltage is applied to the power supply, the 3.15 A fuse and varistor (VA001) will prevent further damage. If a high voltage results in the 3.15 A fuse melted down, the varistor (VA001) should have deteriorated and destroyed. Therefore replace it at the same time.

Caution

The primary circuit of the transformer (T001) has a voltage to ground. Guard against electric shocks.

2. Reset Circuit

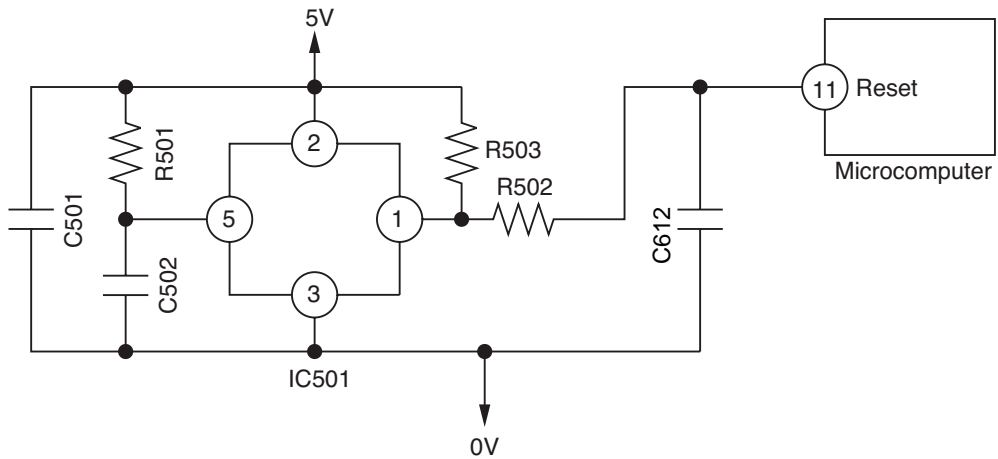

Fig.2-1

Timing chart

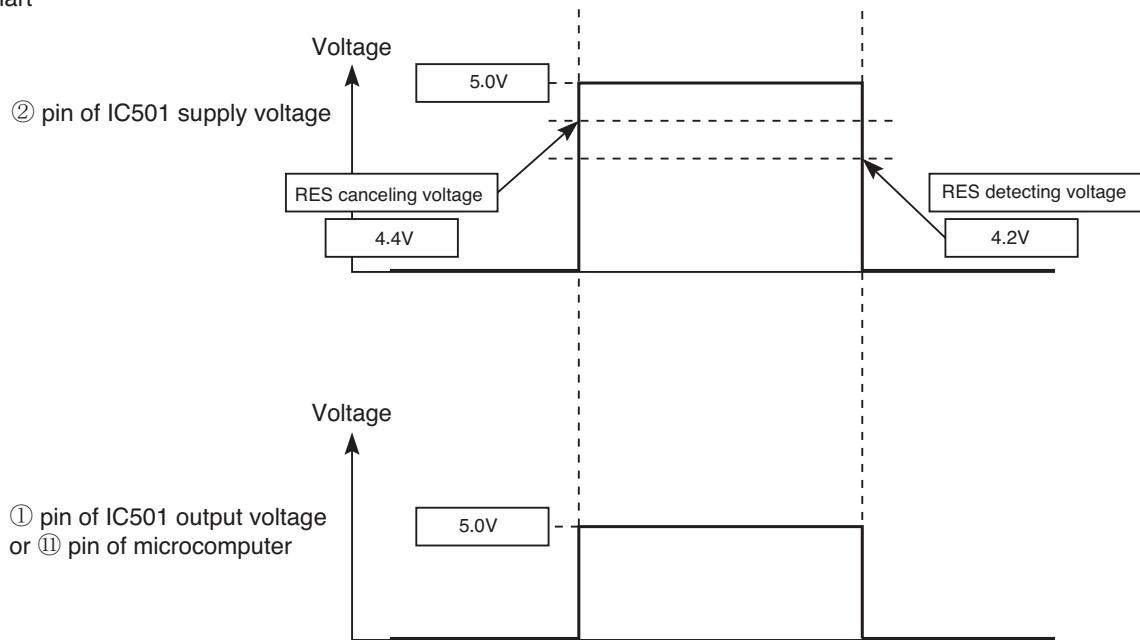

Fig.2-2

- Reset circuit is to initialize the indoor unit microcomputer when switching ON the power or after recovering from power failure.
- Microcomputer operates when ⑪ pin of the indoor unit microcomputer (reset input) is "Lo" for resetting and "Hi" for heating.
- Waveform of each part when switching ON the power and when shutting down is shown in the Fig. 2-2.
- After switching ON the power, ① pin of IC501 supply voltage and ⑪ pin of microcomputer becomes Hi when DC5V line rises and reaches approximately 4.4V or higher. Then, resetting will be cancelled and microcomputer starts operating.
- After shutting down the power, ① pin of IC501 supply voltage and ⑪ pin of microcomputer becomes Lo when DC5V line falls and reaches approximately 4.2V or lower. Then, the microcomputer will be in reset condition.

3. Drive circuit of the indoor fan motor

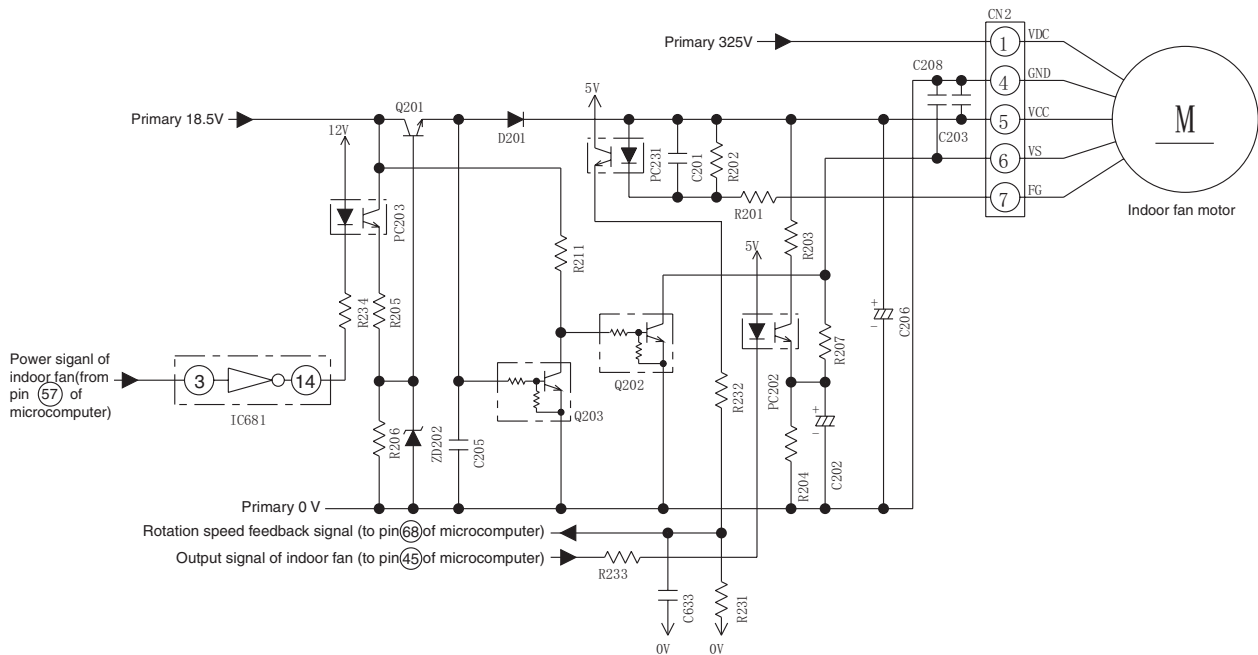
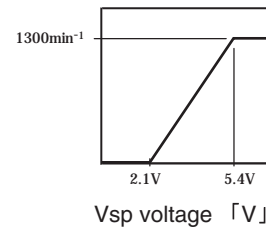

Fig. 3-1

< The circuit check (For test) >

Name	Test point	Test voltage
Motor drive power	CN2 ① pin- ④ pin	About 325V
Motor control power	CN2 ⑤ pin- ④ pin	About 15V
Motor speed signal	CN2 ⑥ pin- ④ pin	About 2-6V
Motor rotation speed debug	CN2 ⑦ pin- ④ pin	About 7.5V

< Pin 6 - Pin 4 voltage one example >



- * The voltage above is all motor operation vol. when you start the test, take care of your connector, do not touch the different pin together.
- * The voltage of pin ⑥ - pin ④ , pin ⑦ - ④ maybe different from above.

* The different mode maybe have different FAN rotation speed.

< Typical circuit waveform >

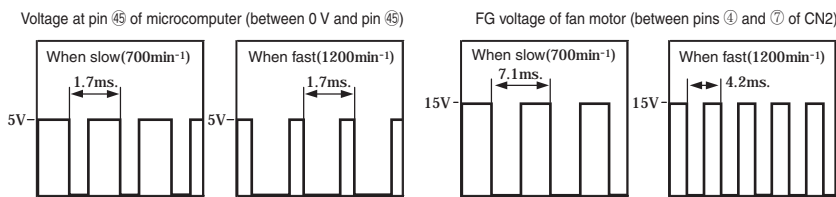

Fig. 3-2

- The indoor fan motor receives VDC (motor drive power supply), VCC (power supply for the control circuit inside the motor), and VS (speed command voltage) from CN2. The indoor fan motor returns an FG signal of a frequency that matches the rotation speed.
- VCC stabilizes the primary 18.5 V power supply into 15 V by using Q201 and supplies it.
- While on standby for a remote control signal, the Q201 shuts down the VCC and reduces the standby power.
- The VS receives a command voltage from the microcomputer (IC601). The VS terminal undergoes an analog voltage that matches the Lo level time ratio of the pulse signal from pin ④5 of the microcomputer. (See Fig. 3-2.)
- The FG terminal undergoes a signal of 12 pulses per revolution of the motor shaft. By counting the pulse rate, the microcomputer (IC601) recognizes the motor speed, thereby performing feedback control.

Caution

The indoor fan motor and drive circuit are connected to the primary power supply. They therefore have voltage to ground. Guard against electric shocks.

Caution

While the product is energized, do not under any circumstances detach or reattach a connector. Any such practice would cause a high voltage to run, resulting in the indoor fan motor and board circuit being destroyed. (Check the discharge of the C003 before detaching or reattaching the connectors.)

4. Buzzer Circuit

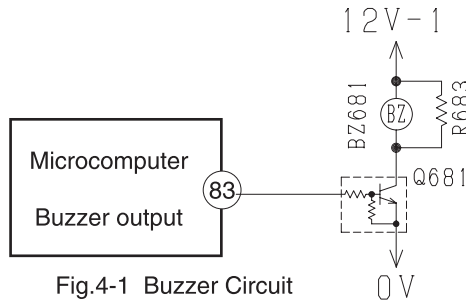

Fig.4-1 Buzzer Circuit

- When the buzzer sounds, an approx. 3.9kHz square signal is output from buzzer output pin (83) of the micro computer. After the amplitude of this signal has been set to 12Vp-p by a transistor, it is applied to the buzzer. The piezoelectric element in the buzzer oscillates to generate the buzzer's sound.

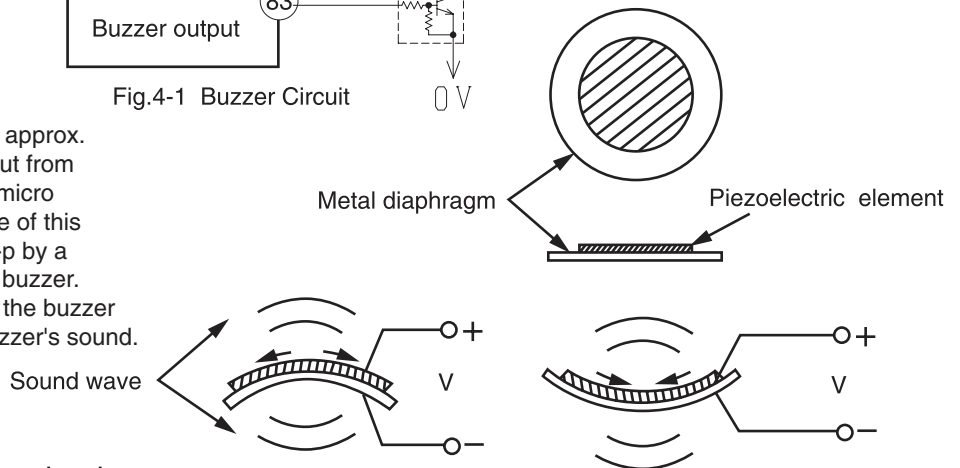

Fig.4-2 Buzzer Operation

5. Remote control reception circuit

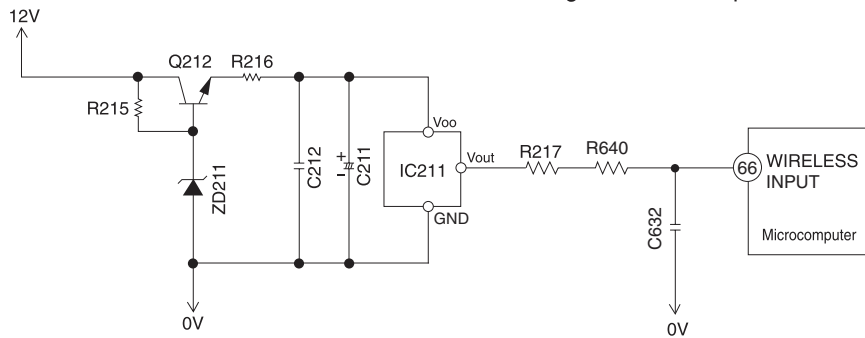

Fig.5-1

[Typical communication waveform]

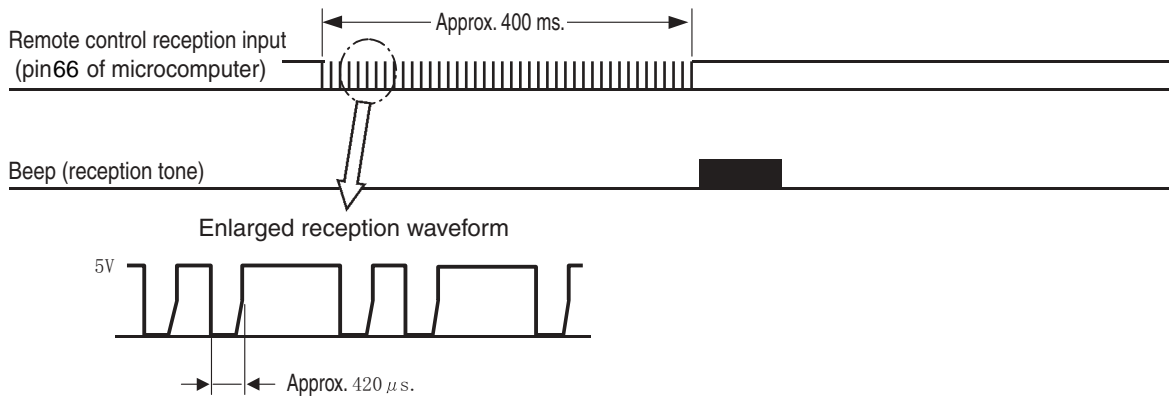
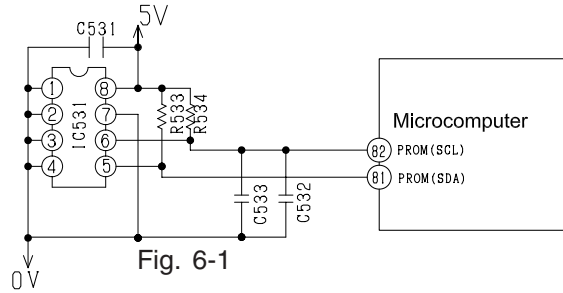

Fig. 5-2

- An infrared signal from the remote control unit is converted to an electrical signal by the remote control light-receiving unit (IC821) and is received by the microcomputer. Data is transmitted as digital data 0 and 1 by changing the interval of the basic pulses at about 420μs.

6. Initial Setting Circuit (IC531)

- When power is supplied, the microcomputer reads the data in IC531 (E²PROM) and sets the preheating activation value and the rating and maximum speed of the compressor, etc. to their initial values.
- Data of self-diagnosis mode is stored in IC531; data will not be erased even when power is turned off.



7. Temporary Switch Circuit

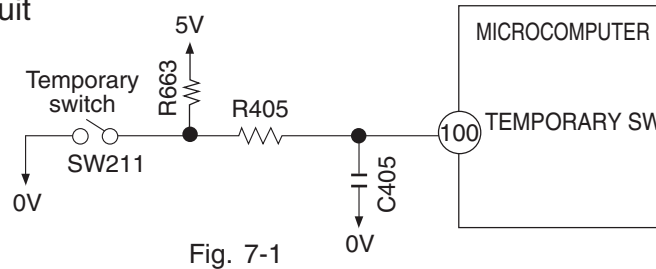

- The temporary switch is used to operate the air conditioner temporarily when the wireless remote control is lost or faulty.
- The air conditioner operates in the previous mode at the previously set temperature. However, when the power switch is set to OFF, it starts automatic operation.

8. Room Temperature Thermistor Circuit

A room temperature thermistor circuit is shown in Fig. 8-1.

According to room temperature, the voltage of point (A) becomes as it is shown in Fig.8-2.

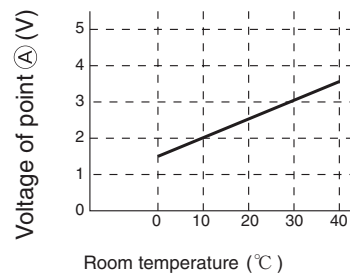
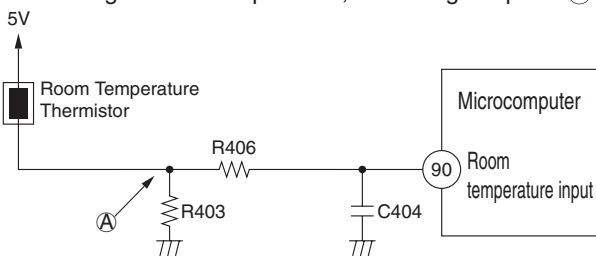

9. Heat Exchanger Thermistor Circuit

Heat exchanger temperature is noticed inside the room

- (1) Preheating
- (2) Low-temperature defrosts at cooling and dehumidification operation time.
- (3) Not working of reversing valve or detection of opening of heat exchange thermistor is controlled.

According to heat exchange temperature, the voltage of point (A) becomes as it is shown in Fig. 9-2.

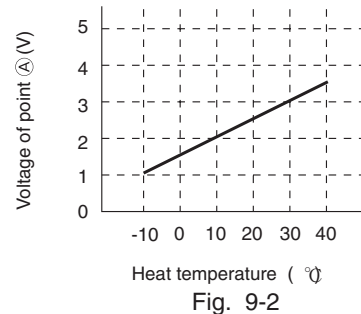
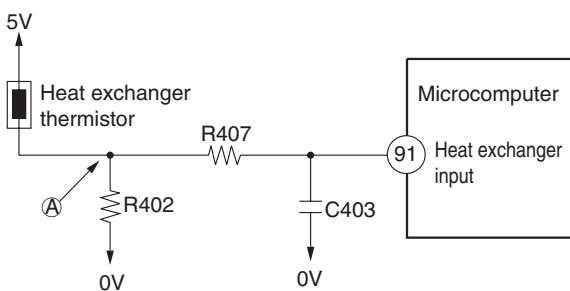

10. Dip-switch

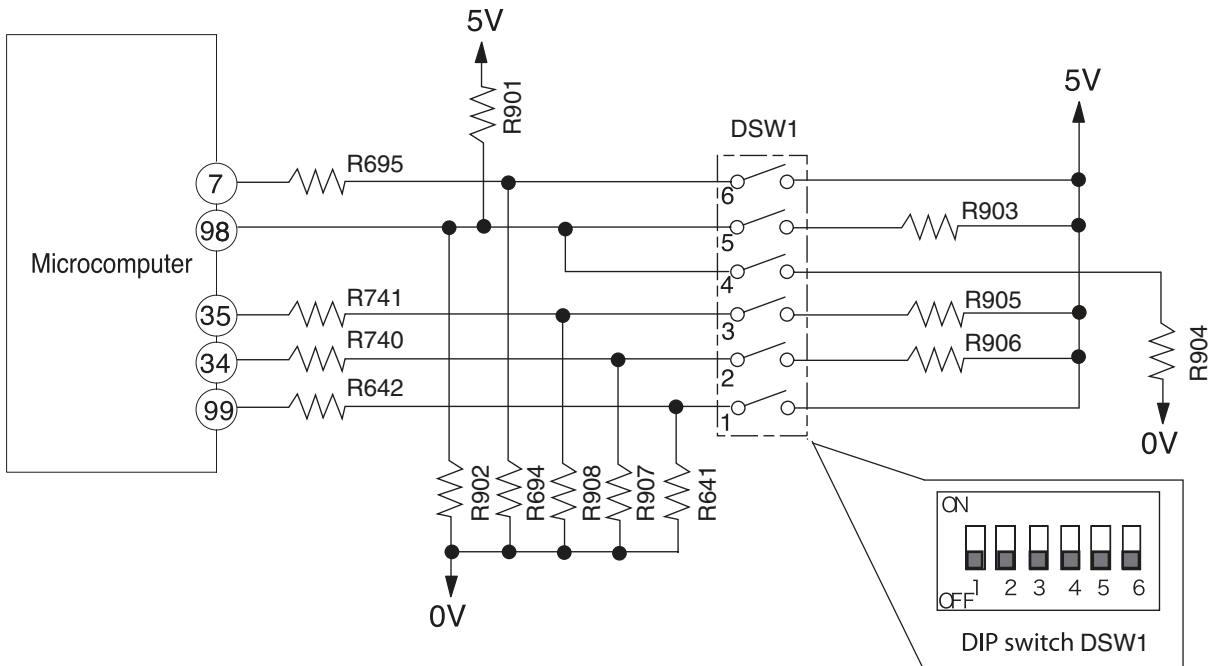

Fig.10-1 Dip switch Circuit

- Fig.10-1 shows the dip switch circuit; the table shown in Fig.10-2 are function and setting position from ①–⑥ of the switch no.

SW No.	I T E M	F U N C T I O N							
		OFF*	ENABLE	ON	DISABLE				
1	AUTO RESTART	OFF*	ENABLE	ON	DISABLE				
2	CARD KEY MODE	OFF*	DISABLE	ON	ENABLE				
3	CARD KEY LOGIC SELECT	OFF*	INPUT HIGH ACTIVE	ON	INPUT LOW ACTIVE				
4	HEATING/COOLING ONLY MODE SELECT	OFF*	HEATING & COOLING	OFF	HEATING ONLY	ON	COOLING ONLY	ON	HEATING & COOLING
5	HEATING/COOLING ONLY MODE SELECT	OFF*		ON		OFF		ON	
6	REMOCON ID SELECT	OFF*	SELECT ID : A	ON	SELECT ID : B				

Fig.10-2 Functions of Dip switch

NOTE:

* Marking is position of shipping [FACTORY default setting]

11. Indoor/outdoor communication circuits

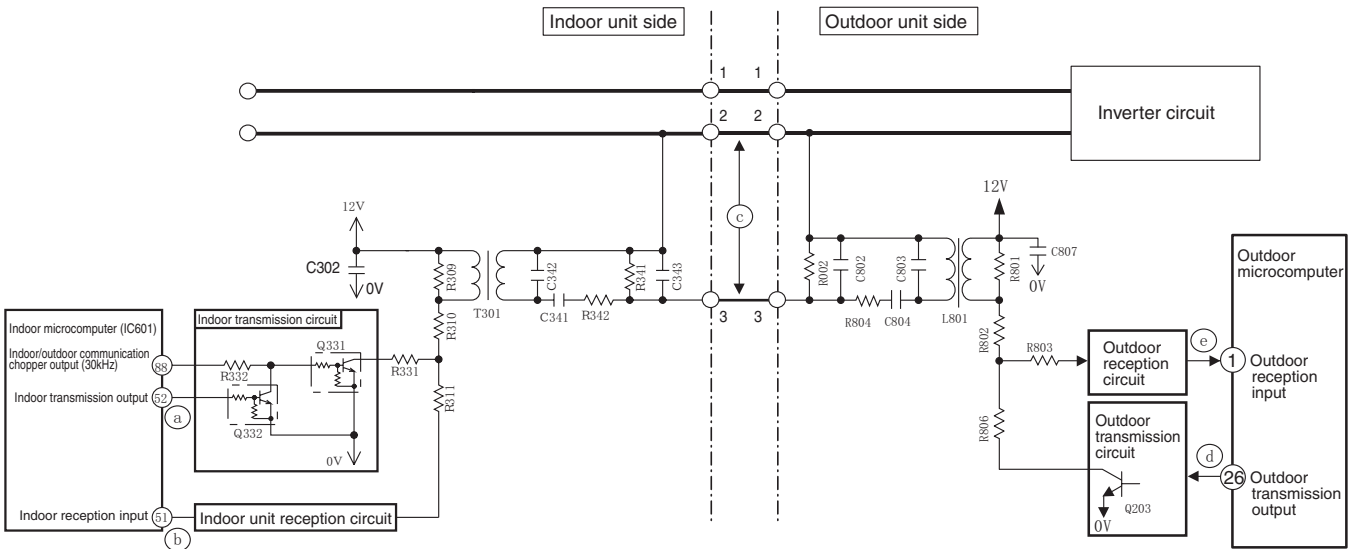

Fig. 11-1

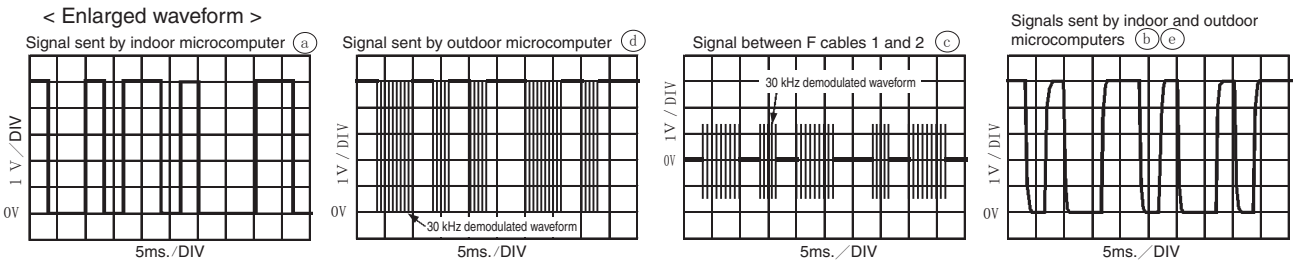
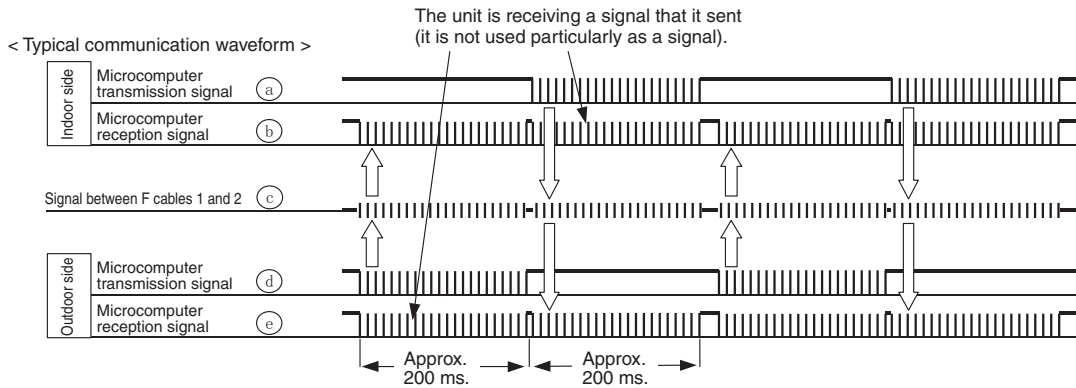

Fig. 11-2

- Indoor and outdoor communications are conducted by using lines 2 and 3 of F cable. Line 2 of F cable is shared with a transmission channel that powers the outdoor unit.
- Data communicated between the indoor and outdoor units are outputted from the microcomputer as serial signals and are transmitted as demodulated by a 30 kHz carrier wave. (Both the indoor and outdoor microcomputers directly output a signal demodulated at 30 kHz.)

Check

If a cable poorly inserted in the indoor terminal board or some other failure overheats the terminal board and the temperature fuse of the terminal board blows out, the power to the indoor communication circuit will be shut down to stop the communications function. (In that case, the failure will be displayed by the timer lamp blinking 3 times.)

Check

If communication fails between the indoor and outdoor units for some reason, the product will give a self-diagnosis display either by "the timer lamp blinking 3 times" or "the timer lamp blinking 12 times" depending on the cause.

12. Stepping motor drive circuit

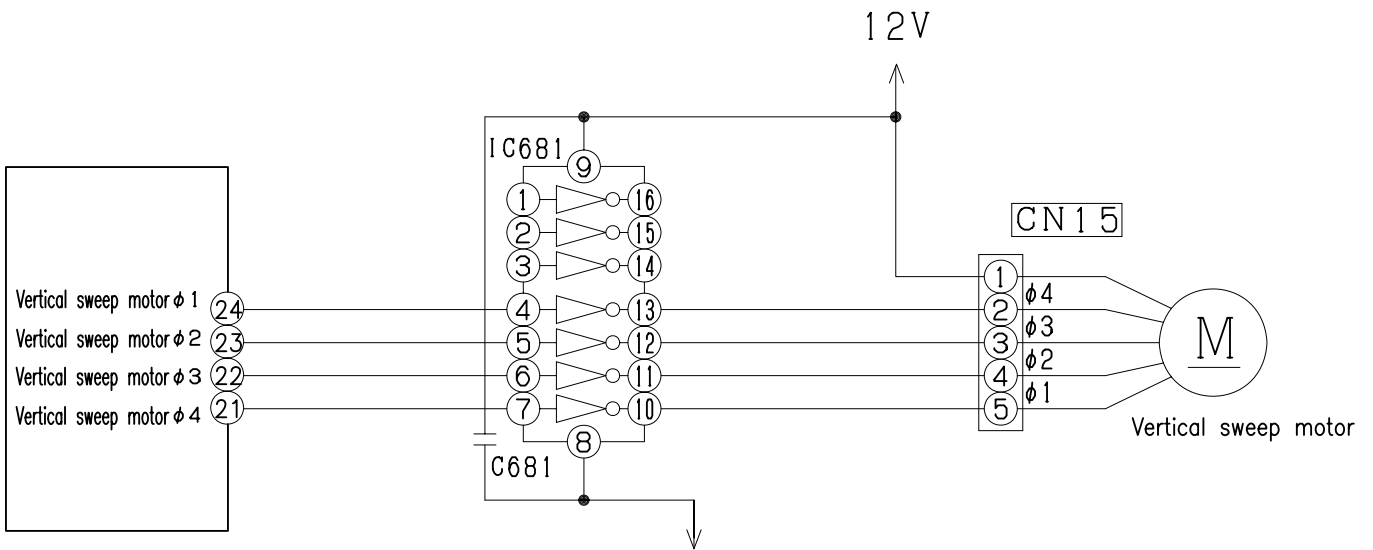

Fig. 12-1

[Connector circuit waveform while the motor runs]

Voltage waveforms of different phases as viewed from the OV line while the motor rotor is turning counterclockwise as viewed from the shaft side

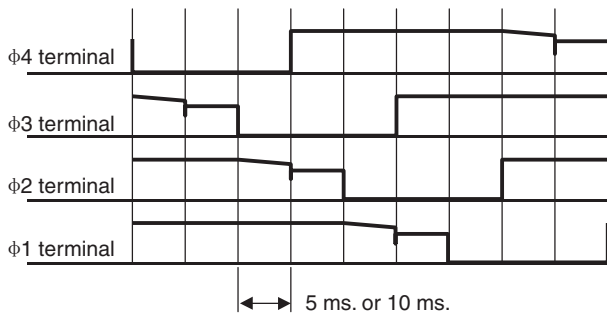

Fig. 12-2

- Each stepping motor runs as excited in 1 or 2 phases at 100 PPS or 200 PPS.
- The excitation pattern passes the microcomputer (IC601) and then the driver IC and excites the coil of each stepping motor.

MODEL RAC-18/25/35WEB

1. Power Circuit

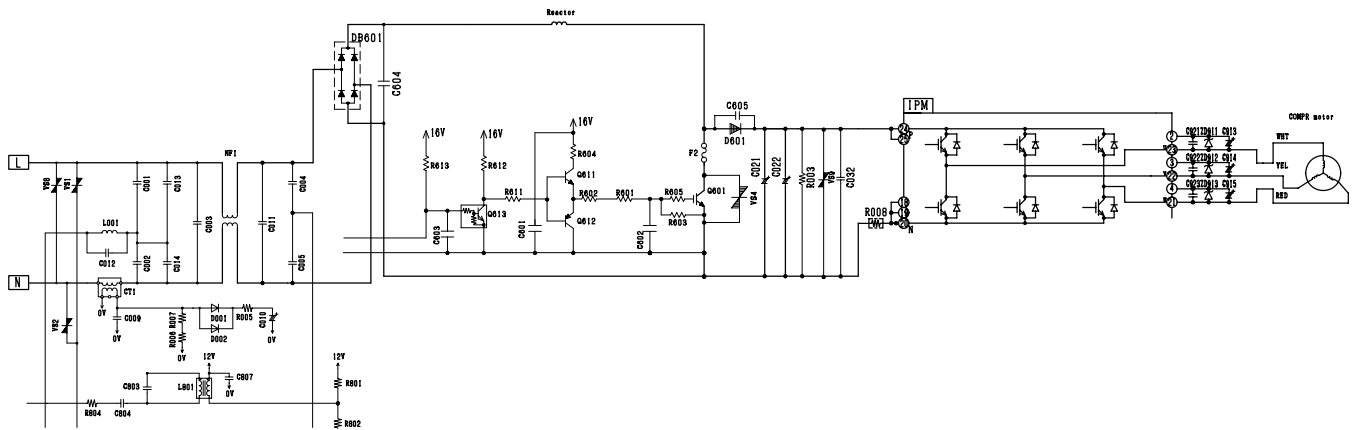

Fig 1-1

※ This circuit full-wave rectifies 230VAC applied between terminals L and N and boosts it to a required voltage with the IPM to create a DC voltage.

The voltage become 300-330V when the compressor is operated.

※ Main parts

(1) Intelligence Power Module (IPM)

A module that constitute by an inverter part.

(2) Diode Stack (DB601)

These rectify the 230VAC from terminal L and N to a DC power supply.

(3) Smoothing capacitors (C021-C022,375 μ F,420V)

(4) IGBT to improve efficiency (Q601)

<Reference>

※ In case of Intelligence Power Module malfunction or connection failure immediately after compressor starts, its may stop due to error of [abnormal low speed],[switching failure],[Ip stop] and others.

<Reference>

※ If diode stack (DB601) are faulty, DC voltage may not be generated and the compressor may not operate at all. Also be aware that the 15A fuse might have blown.

※ This smoothes (averages) the voltage rectified by the diode stack.

※ It will improve the efficiency during compressor load become heavy when current flow thru the chopper period of Q601.

2. Power circuit (Low voltage)

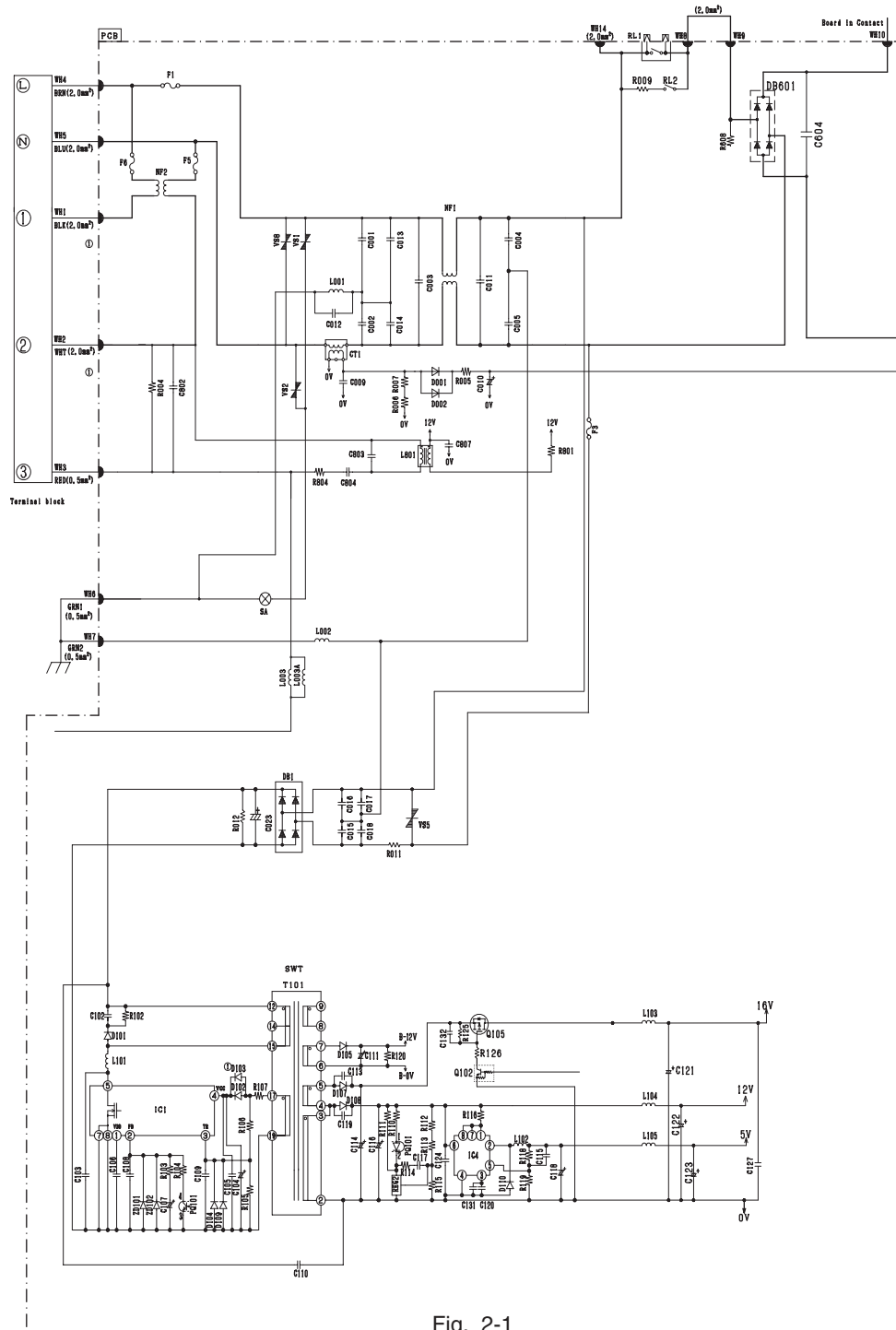

Fig. 2-1

- The 230V AC voltage is rectified to DC voltage (B-12V,16V,12V,5V) pass through switching control IC (IC1), switching transformer.
 - (1) B-12V Power supply for electrical expansion valve.
 - (2) 16V Power supply for IPM driver circuit of compressor and fan motor, IGBT action.
 - (3) 12V Power supply for 4 way valve relay, power relay, inrush current relay, motor current amplification,
 - (4) 5V Power supply for microcomputer, peripheral circuits.

Main parts

(1) C001,C002,C003,C004,C005,C011,C013,C014, NF1

These absorb electrical noise generated during operation of compressor and also absorb external noise entering from power line to protect electronic parts.

(2) Surge Absorber, Varistor1,2,5,8.

These absorbs external power surge.

(2) IC4

DC/DC convertor IC (DC12V → DC5V).

3. P.W.B. for power circuit

Voltage specification of power circuit as shown in below table.

<Checking point>

Output	Spec	Main load	Measuring point	Example of possible failure mode.
5V O/P	$5 \pm 0.4V$	Micon, Thermistor	Tester⊕ : L105 (JUMPER) Tester⊖ : D110 (EARTH)	Outdoor not operate, no blinking indication
12V O/P	$12 \pm 0.5V$	Micon, IC2, 3, 4 Relay circuit	Tester⊕ : L104 (JUMPER) Tester⊖ : D110 (EARTH)	Outdoor not operate, no blinking indication
16V O/P	$15.5^{+1.5V}_{-1.0V}$	IPM for Comp IPM for DC fan	Tester⊕ : L103 (JUMPER) Tester⊖ : D110 (EARTH)	Stop : LD301 3,4 or 12 times blinking
B-12V O/P	$13^{+2.5V}_{-1.0V}$	Expansion valve	Tester⊕ : R120 (B-12V) Tester⊖ : R120 (B-0V)	Stop : LD301 5 times blinking

※ Power circuit for P.W.B can consider normal if the result is satisfied with above specification.

4.Reversing valve control circuit

This model reversing valve control used to control the relay ON/OFF of the revesing valve, and also control the coil of the reversing valve ON/OFF.

The relay ON/OFF has different type when in the different operation mode.

You can see each operation mode as flows. If the reaversing valve not connected or all the condition not the same as follow, it may be something wrong with the reversing valve circuit.

Point operation mode		micon (28pin - 0V	HIC (34 pin - 0V	CN2(1)- CN2(4)
		Cooling	Usual cooling	Hi
Heating	Usual heating	Lo	12V	0V
	Defrost	Hi	0V	AC230V

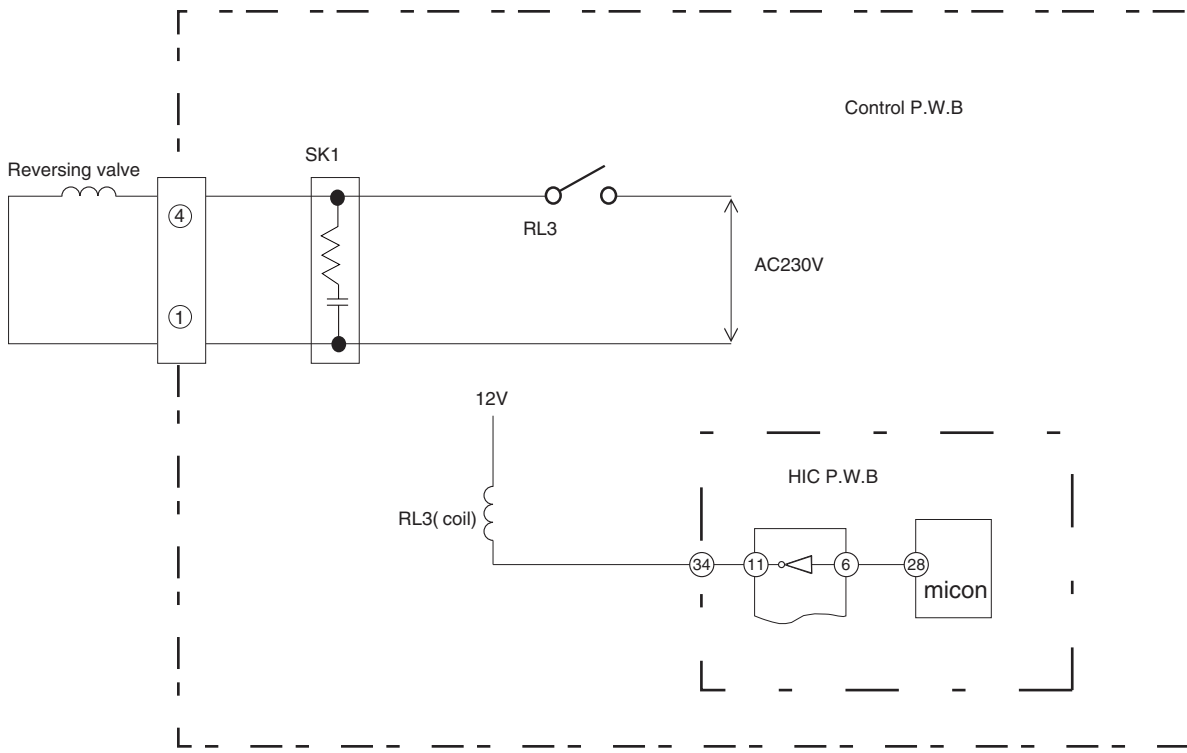

Fig.4-1

5. Temperature Detection Circuit

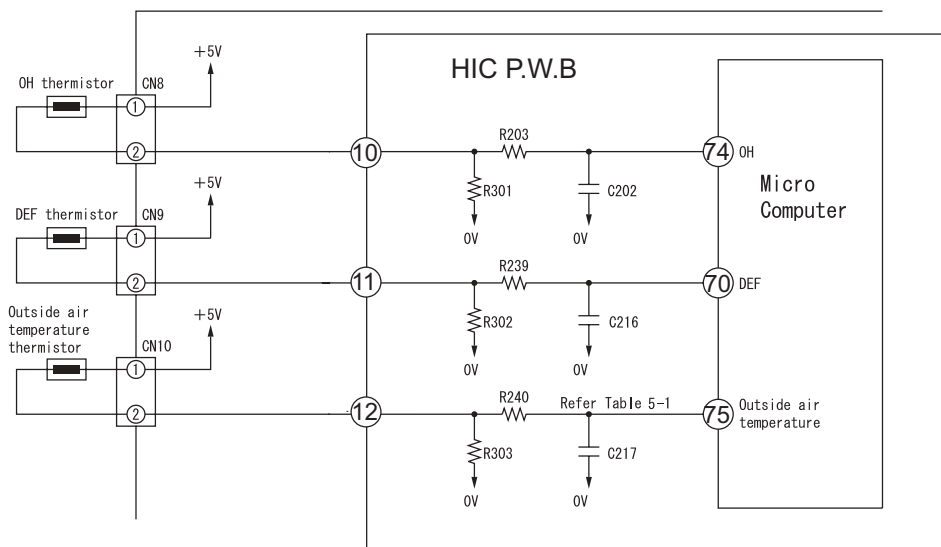

Fig.5-1

- OH thermistor circuit detect the temperature at the surface of compressor head, DEF thermistor circuit detect the defrosting operation temperature.
 - A thermistor is a negative resistor element which has characteristics that the higher(lower) the temperature, the lower(higher) the resistance.
 - When the compressor is heated, the resistance of the OH thermistor becomes low and $\oplus 5V$ is divided by OH thermistor and R301 and the voltage at pin (74) of microcomputer.
 - Compare the voltage at microcomputer pin (74) and setting value stored inside. If the value exceed the set value, microcomputer will judge that the compressor is overheated and stop the operation.
 - When frost is formed on the outdoor heat exchanger, the temperature at the exchanger drops abruptly. Therefore the resistance of the DEF thermistor becomes high and the voltage at pin (70) of micro computer drops. If this voltage becomes lower than the set value stored inside, microcomputer will enter the defrost control.
 - During defrost operation, the microcomputer will transfer the defrosting condition command to indoor unit via SDO pin of interface of IF transmission output.
 - The microcomputer read the outdoor temperature by Outside Air thermistor and transfer it to the indoor unit, thus controlling the compressor rotation speed according to the set value in the EEPROM of indoor unit and switching the operation mode (outdoor fan on/off etc.) to DRY mode.
- Below table show the typical values of outdoor temperature in relation to the voltage.

Table 5-1

Outside Air Temperature (°C)	-10	0	10	20	30	40
Voltage at both side of R303 (V)	1.19	1.69	2.23	2.75	3.22	3.62

<Reference>

When the thermistor is open, open condition or disconnect, microcomputer pin(70)(74)(75)are approx. 0V;

When thermistor is shorted, they are approx. 5V and LD301 will blink 7 times.

However, an error is detected when only the OH thermistor is shorted and will enter blinking mode after 12 minutes start the compressor operation.

6. Electric expansion valve circuit

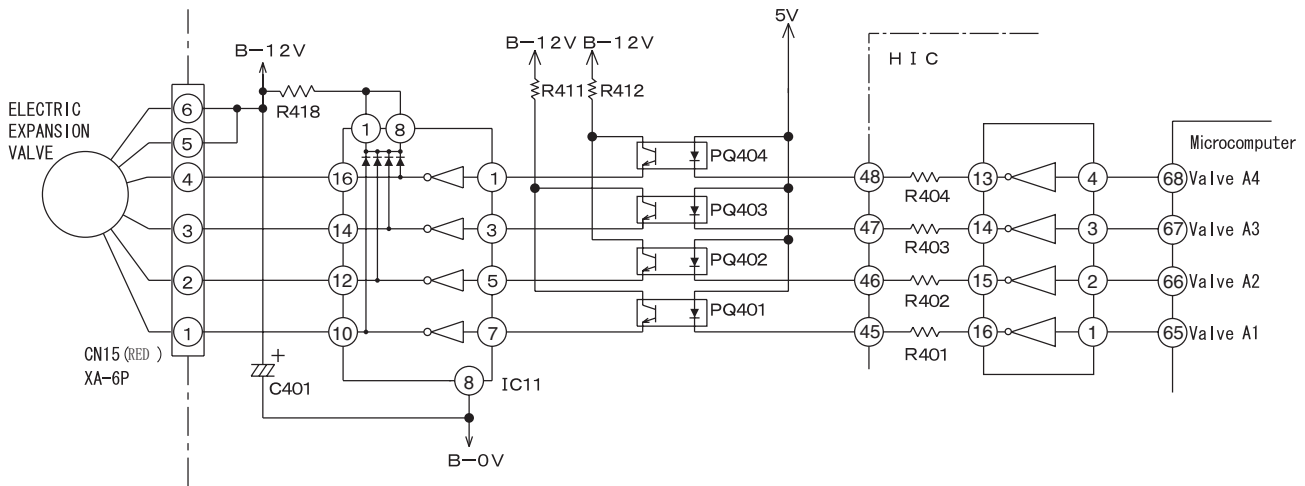

Fig. 6-1

- The electric expansion valve is driven by DC12V. Power is supplied to 1 or 2 phases of 4-phase winding to switch magnetic pole of winding in order to control the opening degree.
- Relationship between power switching direction of phase and open/close direction is shown below. When power is supplied, voltages at pins ④ to ① of CN15 are about 0.9V and 12V when no power is supplied. When power is reset, initial operation is performed for 10 or 20 seconds. During initial operation, measure all voltages at pin ④ to ① of CN15 by using a multimeter. If there is any pin with voltage that has not changed from 0.9V or 12V, expansion valve or microcomputer is broken.
- Fig. 6-2 shows logic waveform when expansion valve is operating.

Table 6-1

CN15 pin no.	Wire	Drive status							
		1	2	3	4	5	6	7	8
①	WHT	ON	ON	OFF	OFF	OFF	OFF	OFF	ON
②	YEL	OFF	ON	ON	ON	OFF	OFF	OFF	OFF
③	ORG	OFF	OFF	OFF	ON	ON	ON	OFF	OFF
④	BLU	OFF	OFF	OFF	OFF	OFF	ON	ON	ON

Operation mode
 1→2→3→4→5→6→7→8 VALVE CLOSE
 8→7→6→5→4→3→2→1 VALVE OPEN

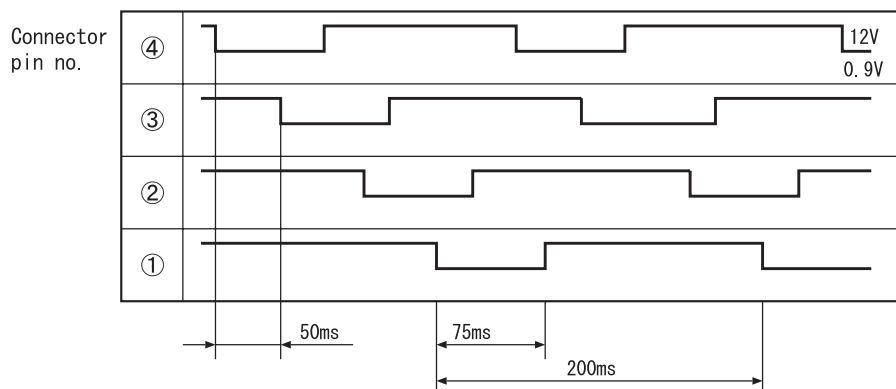

Fig. 6-2

With expansion valve control, opening degree is adjusted to stabilize target temperature by detecting compressor head temperature. The period of control is about once per 20 seconds and output a few pulse.

7. Outdoor DC fan motor control circuit

- This model is built with DC fan motor control circuit inside outdoor electrical unit.

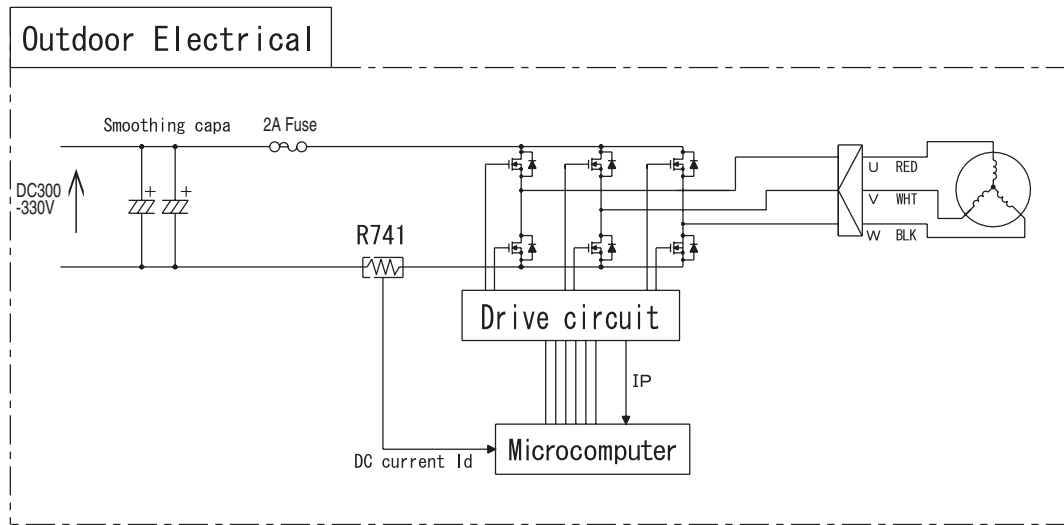

Fig 7-1

This DC fan motor is control by outdoor microcomputer that follow the operating instruction received from indoor microcomputer. The DC current that flow from R741 will presume actual operation speed and control the rotation to follow the operating instruction. Based on this DC current it will detect a over current and other fan motor failure.

(1) Fan motor speed controller during starting

Due to the interference of strong wind etc., operation movement is changed based on fan direction and rotation speed as shown below during starting of operation.

In addition, the fair wind is define as wind that blow to outside direction using Mouth Ring part. At strong and contrary wind ... The rotational speed is not controlled as to protect the equipment and fan will rotate reversely depend on the wind. Automatically start when wind condition become weak.

At contrary wind ... The rotational speed is controlled in fair wind direction after it slowly reduce the speed and finally stop.

At fair wind ... The rotational speed is controlled as it is.

At strong fair wind ... The rotational speed is not controlled as to protect the equipment and fan will rotate reversely depend on the wind. Automatically start when wind condition become weak.

(2) Fan motor speed controller during unit operating

There is a case where fan rpm is reducing during rotating caused by interference of strong wind. If this condition continue in long period, fan will stop rotating. (LD301 : 11 times blinking) The unit will restart according to control as per during start (1).

(3) Method of confirming self diagnosis LD301 lamp : 12 times blinking

If the unit stop and LD301 on the pwb blinking 12 times [fan lock stop is detected], follow below steps to confirm it.

1. Fan lock stop is detected when something has disturb the fan rotation by inserting material into propeller fan or ice has growing inside outdoor unit caused by snow.
Remove it if found something is bloking the fan.
2. Confirmed that CN24 connector is securely inserted. Fan lock stop is detected also when connector is not properly inserted. Please securely insert if found any disconnection.
3. Fan lock stop also can be detected where strong wind blown surrounding the unit.
Please confirm after restart the unit. (It may take few minutes to operate the compressor)
It is not a malfunction of electrical unit or fan motor if the unit run continously after restart the unit.
4. Check fan motor condition as below procedure.

[Checking Fan Motor] procedure

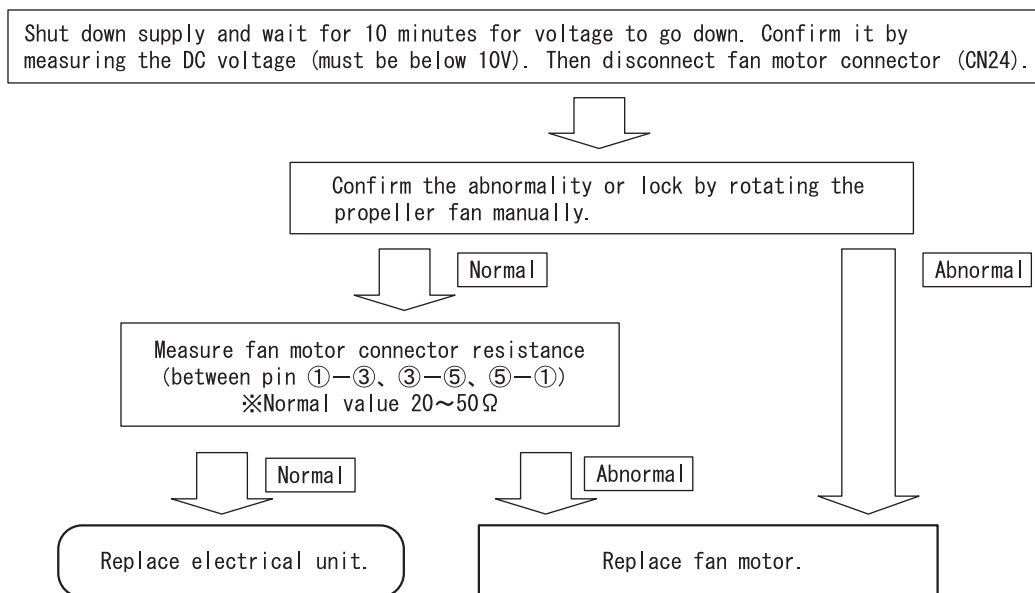

5. Reconnect again fan motor connector (CN24).

※Please confirm above checking procedure if found 2A fuse blown.

If fan motor is broken, replace both electrical unit and fan motor.

Caution

※Beware of electric shock due to high voltage when conducting an operation check.

Power supply for DC fan motor and compressor is common (DC300-330V).

MODEL RAC-50WEB

1. Power Circuit

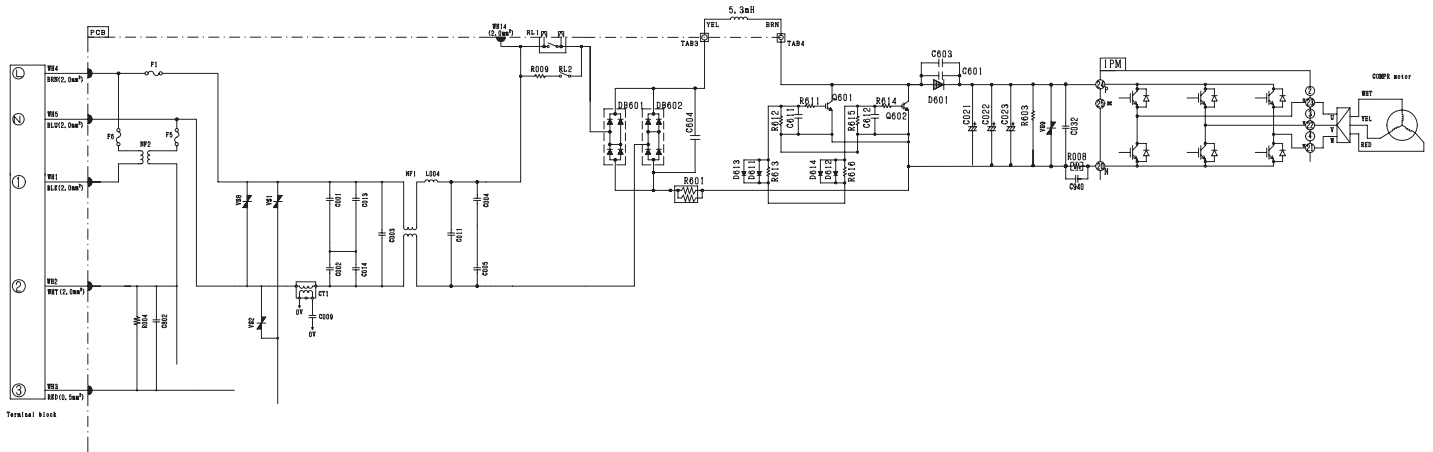

Fig 1-1

※ This circuit full-wave rectifies 230VAC applied between terminals L and N and boosts it to a required voltage with the IPM to create a DC voltage.

The voltage become 300-330V when the compressor is operated.

※ Importance component

- (1) Intelligence Power Module (IPM)
A module that constitute by an inverter part.
- (2) Diode Stack (DB601, DB602)
These rectify the 230VAC from terminal L and N to a DC power supply.

<Reference>

※ In case of Intelligence Power Module malfunction or connection failure immediately after compressor starts, its may stop due to error of [abnormal low speed], [switching failure],[Ip stop] and others.

<Reference>

※ If diode stack (DB601, DB602) are faulty, DC voltage may not be generated and the compressor may not operate at all. Also be aware that the 25A fuse might have blown.

(3) Smoothing capacitors (C021-C023, 500 μ F, 450V)

This smoothes (averages) the voltage rectified by the diode stack.

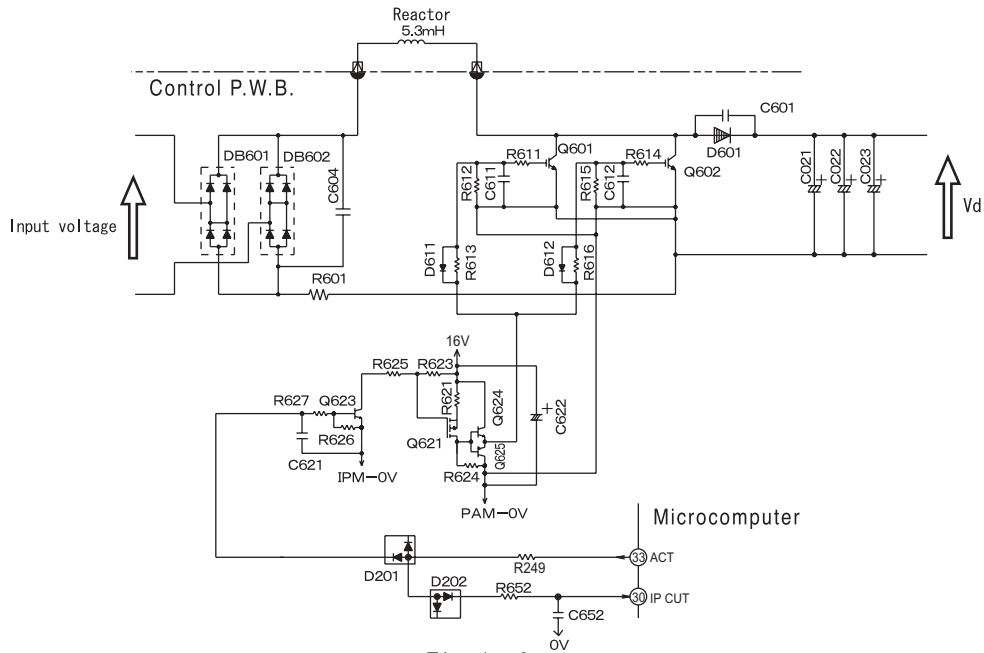

Fig. 1-2

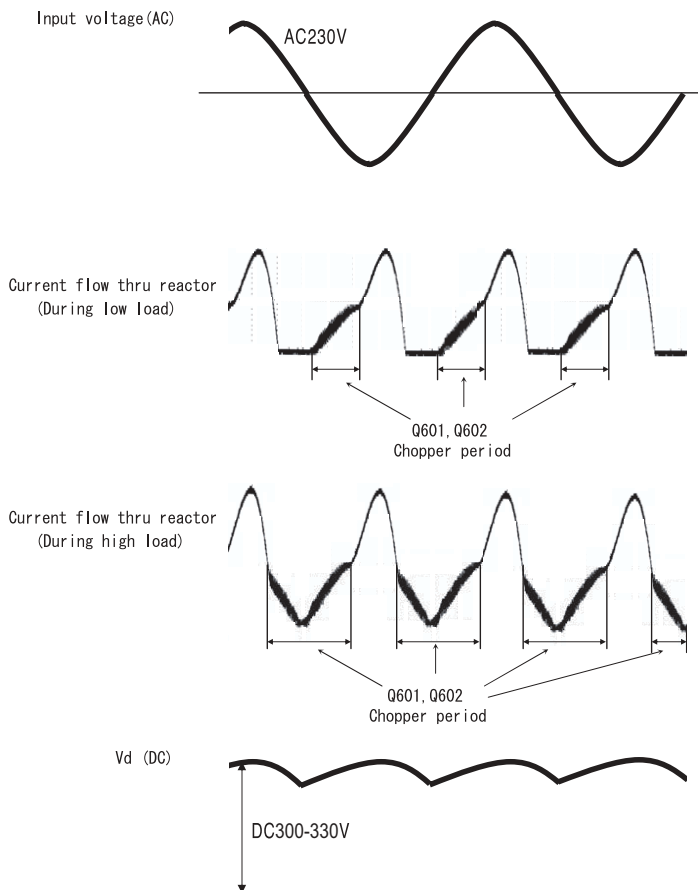

Fig. 1-3

(4) IGBT to improve efficiency (Q601, Q602)

It will improve the efficiency during compressor load become heavy when current flow thru the chopper period of Q601, Q602.

2. Power circuit (Low voltage)

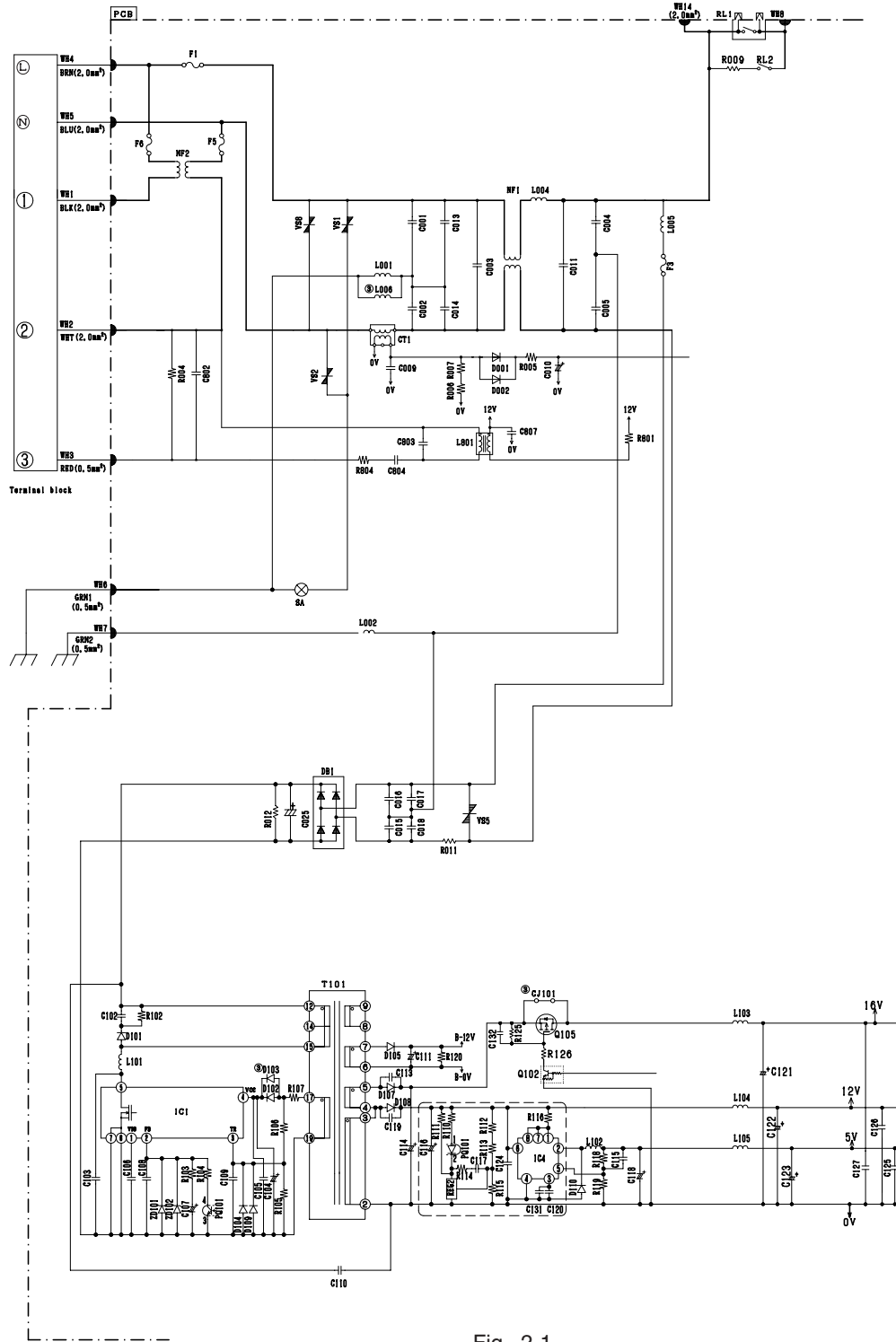

Fig. 2-1

- The 230V AC voltage is rectified to DC voltage (B-12V,16V,12V,5V) pass through switching control IC (IC1), switching transformer.
 - (1) B-12V Power supply for electrical expansion valve.
 - (2) 16V Power supply for IPM driver circuit of compressor and fan motor, IGBT action.
 - (3) 12V Power supply for 4 way valve relay, power relay, inrush current relay, motor current amplification,
 - (4) 5V Power supply for microcomputer, peripheral circuits.

Main parts

(1) C001,C002,C003,C004,C005,C011,C013,C014, NF1

These absorb electrical noise generated during operation of compressor and also absorb external noise entering from power line to protect electronic parts.

(2) Surge Absorber, Varistor1,2,5,8.

These absorbs external power surge.

(2) IC4

DC/DC convertor IC (DC12V → DC5V).

3. P.W.B. for power circuit

Voltage specification of power circuit as shown in below table.

<Checking point>

Output	Spec	Main load	Measuring point	Example of possible failure mode.
5V O/P	$5 \pm 0.4V$	Micon, Thermistor	Tester \oplus : L105 (JUMPER) Tester \ominus : D110 (EARTH)	Outdoor not operate, no blinking indication
12V O/P	$12 \pm 0.5V$	Micon, IC2, 3, 4 Relay circuit	Tester \oplus : L104 (JUMPER) Tester \ominus : D110 (EARTH)	Outdoor not operate, no blinking indication
16V O/P	$15.5^{+1.5V}_{-1.0V}$	IPM for Comp IPM for DC fan	Tester \oplus : L103 (JUMPER) Tester \ominus : D110 (EARTH)	Stop : LD301 3, 4 or 12 times blinking
B-12V O/P	$13^{+2.5V}_{-1.0V}$	Expansion valve	Tester \oplus : R418 (B-12V) Tester \ominus : C401 (" - ")	Stop : LD301 5 times blinking

※ Power circuit for P.W.B can consider normal if the result is satisfied with above specification.

4.Reversing valve control circuit

This model reversing valve control used to control the relay ON/OFF of the revesing valve, and also control the coil of the reversing valve ON/OFF.

The relay ON/OFF has different type when in the different operation mode.

You can see each operation mode as flows. If the reaversing valve not connected or all the condition not the same as follow, it may be something wrong with the reversing valve circuit.

Point operation mode		micon (28)pin - 0V	HIC (28) pin - 0V	CN2(1)- CN2(4)
		Cooling	Usual cooling	Hi
Heating	Usual heating	Lo	12V	0V
	Defrost	Hi	0V	AC230V

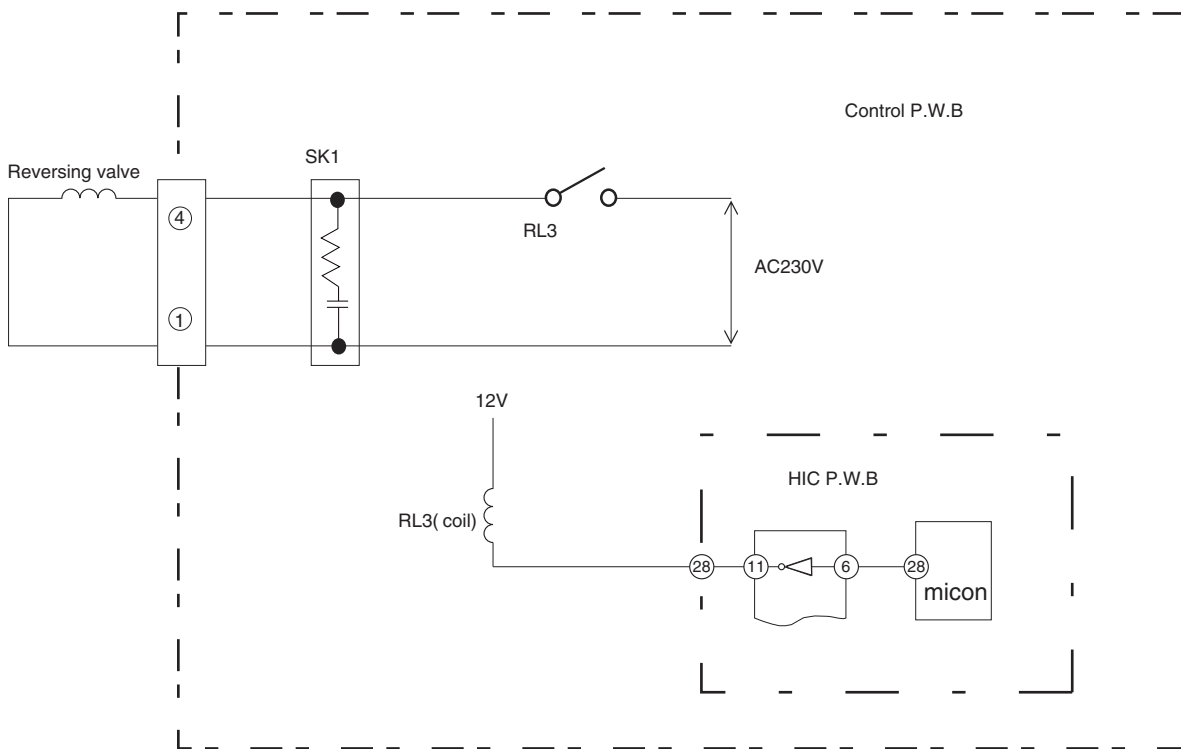

Fig.4-1

5. Temperature Detection Circuit

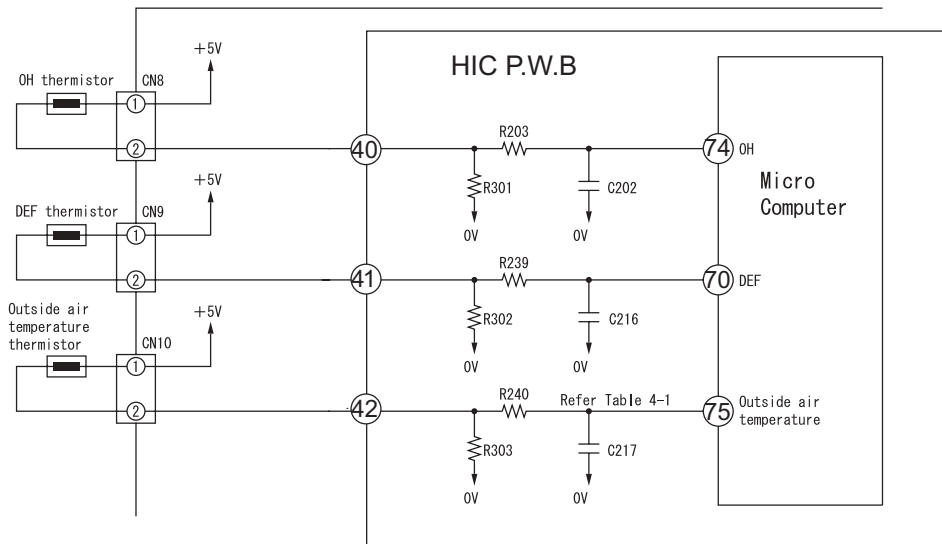

Fig.5-1

- OH thermistor circuit detect the temperature at the surface of compressor head, DEF thermistor circuit detect the defrosting operation temperature.
- A thermistor is a negative resistor element which has characteristics that the higher(lower) the temperature, the lower(higher) the resistance.
- When the compressor is heated, the resistance of the OH thermistor becomes low and $\oplus 5V$ is divided by OH thermistor and R301 and the voltage at pin (74) of microcomputer.
- Compare the voltage at microcomputer pin (74) and setting value stored inside. If the value exceed the set value, microcomputer will judge that the compressor is overheated and stop the operation.
- When frost is formed on the outdoor heat exchanger, the temperature at the exchanger drops abruptly. Therefore the resistance of the DEF thermistor becomes high and the voltage at pin (70) of micro computer drops. If this voltage becomes lower than the set value stored inside, microcomputer will enter the defrost control.
- During defrost operation, the microcomputer will transfer the defrosting condition command to indoor unit via SDO pin of interface of IF transmission output.
- The microcomputer read the outdoor temperature by Outside Air thermistor and transfer it to the indoor unit, thus controlling the compressor rotation speed according to the set value in the EEPROM of indoor unit and switching the operation mode (outdoor fan on/off etc.) to DRY mode.

Below table show the typical values of outdoor temperature in relation to the voltage.

Table 5-1

Outside Air Temperature (°C)	-10	0	10	20	30	40
Voltage at both side of R303 (V)	1.19	1.69	2.23	2.75	3.22	3.62

<Reference>

When the thermistor is open, open condition or disconnect, microcomputer pin(70)(74)(75) are approx. 0V;

When thermistor is shorted, they are approx. 5V and LD301 will blink 7 times.

However, an error is detected when only the OH thermistor is shorted and will enter blinking mode after 12 minutes start the compressor operation.

6. Electric expansion valve circuit

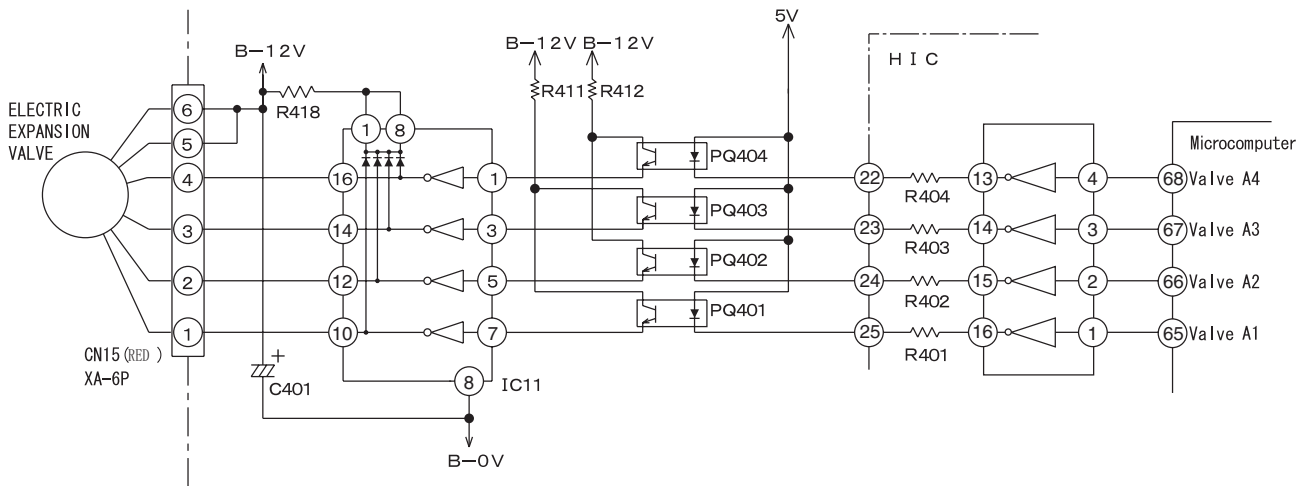

Fig. 6-1

- The electric expansion valve is driven by DC12V. Power is supplied to 1 or 2 phases of 4-phase winding to switch magnetic pole of winding in order to control the opening degree.
- Relationship between power switching direction of phase and open/close direction is shown below. When power is supplied, voltages at pins ④ to ① of CN15 are about 0.9V and 12V when no power is supplied. When power is reset, initial operation is performed for 10 or 20 seconds. During initial operation, measure all voltages at pin ④ to ① of CN15 by using a multimeter. If there is any pin with voltage that has not changed from 0.9V or 12V, expansion valve or microcomputer is broken.
- Fig. 6-2 shows logic waveform when expansion valve is operating.

Table 6-1

CN15 pin no.	Wire	Drive status							
		1	2	3	4	5	6	7	8
①	WHT	ON	ON	OFF	OFF	OFF	OFF	OFF	ON
②	YEL	OFF	ON	ON	ON	OFF	OFF	OFF	OFF
③	ORG	OFF	OFF	OFF	ON	ON	ON	OFF	OFF
④	BLU	OFF	OFF	OFF	OFF	OFF	ON	ON	ON

Operation mode
 1→2→3→4→5→6→7→8 VALVE CLOSE
 8→7→6→5→4→3→2→1 VALVE OPEN

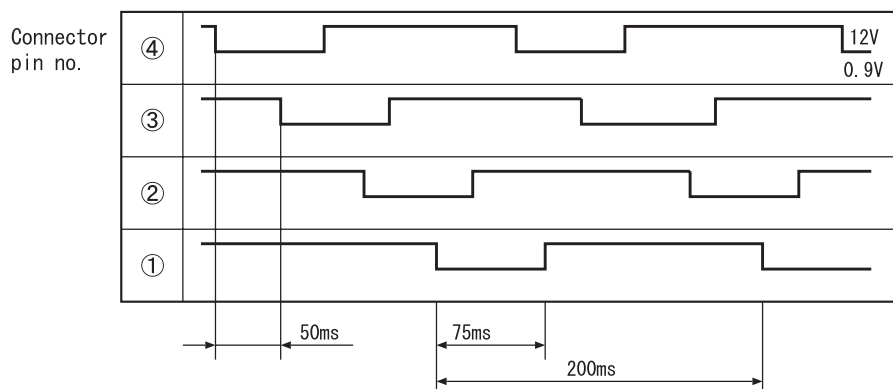

Fig. 6-2

With expansion valve control, opening degree is adjusted to stabilize target temperature by detecting compressor head temperature. The period of control is about once per 20 seconds and output a few pulse.

7. Outdoor DC fan motor control circuit

- This model is built with DC fan motor control circuit inside outdoor electrical unit.

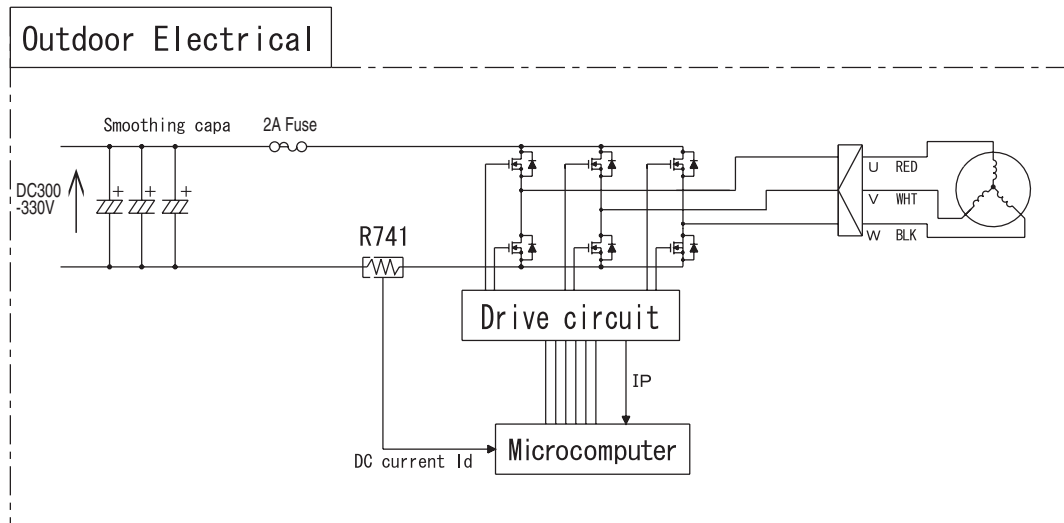

Fig 7-1

This DC fan motor is control by outdoor microcomputer that follow the operating instruction received from indoor microcomputer. The DC current that flow from R741 will presume actual operation speed and control the rotation to follow the operating instruction. Based on this DC current it will detect a over current and other fan motor failure.

(1) Fan motor speed controller during starting

Due to the interference of strong wind etc., operation movement is changed based on fan direction and rotation speed as shown below during starting of operation.

In addition, the fair wind is define as wind that blow to outside direction using Mouth Ring part. At strong and contrary wind ...The rotational speed is not controlled as to protect the equipment and fan will rotate reversely depend on the wind. Automatically start when wind condition become weak.

At contrary wind ...The rotational speed is controlled in fair wind direction after it slowly reduce the speed and finally stop.

At fair wind ...The rotational speed is controlled as it is.

At strong fair wind ...The rotational speed is not controlled as to protect the equipment and fan will rotate reversely depend on the wind. Automatically start when wind condition become weak.

(2) Fan motor speed controller during unit operating

There is a case where fan rpm is reducing during rotating caused by interference of strong wind. If this condition continue in long period, fan will stop rotating. (LD301 : 11 times blinking)
The unit will restart according to control as per during start (1).

(3) Method of confirming self diagnosis LD301 lamp : 12 times blinking

If the unit stop and LD301 on the pwb blinking 12 times [fan lock stop is detected], follow below steps to confirm it.

1. Fan lock stop is detected when something has disturb the fan rotation by inserting material into propeller fan or ice has growing inside outdoor unit caused by snow.
Remove it if found something is bloking the fan.
2. Confirmed that CN24 connector is securely inserted. Fan lock stop is detected also when connector is not properly inserted. Please securely insert if found any disconnection.
3. Fan lock stop also can be detected where strong wind blown surrounding the unit.
Please confirm after restart the unit. (It may take few minutes to operate the compressor)
It is not a malfunction of electrical unit or fan motor if the unit run continuesly after restart the unit.
4. Check fan motor condition as below procedure.

[Checking Fan Motor] procedure

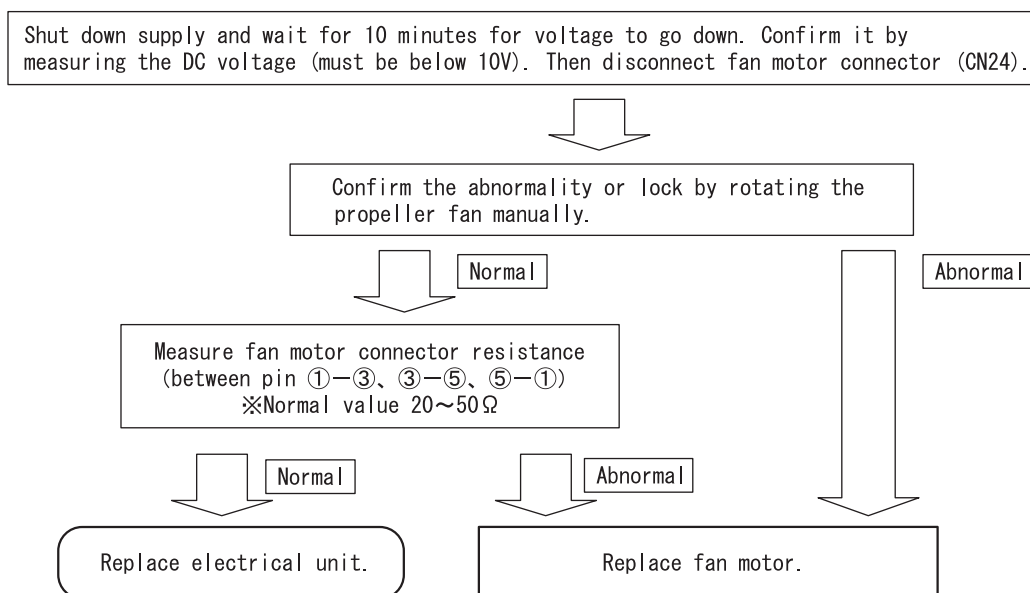

5. Reconnect again fan motor connector (CN24).

※Please confirm above checking procedure if found 2A fuse blown.

If fan motor is broken, replace both electrical unit and fan motor.

Caution

※Beware of electric shock due to high voltage when conducting an operation check.

Power supply for DC fan motor and compressor is common (DC300-330V).

SERVICE CALL Q&A

MODEL RAK-18/25/35/50PEB, RAK-25/35/50PEBC

Cooling operation

Q1 The compressor sometimes stops during cooling.



A1 Check if the heat exchanger of the indoor unit is covered with dew. Wait for 3 to 4 minutes until the dew disappears.

Cooling when the room temperature is low may cause the heat exchanger of the indoor unit to gather dew.

Dehumidification

Q1 The indoor unit produces a noise that goes "shaaahhh" during dehumidification.



A1 That is a noise produced by refrigerant flowing through the pipe.

Q2 Cold air comes out during a dehumidifying operation.



A2 To improve the dehumidification efficiency performs quiet fan operation. Therefore the air is cold and it is not a malfunction.

Q3 The operation does not stop even by setting the temperature higher than room temperature on the remote controller.



A3 It sets to perform dehumidifying operation by setting the temperature slightly lower than remote controller setting.

Heating operation

Q1 The product sometimes fails to produce a wind during heating.



A1 Defrosting is in progress. Wait 5 to 10 minutes until the dew on the outdoor unit disappears.

Q2 The product begins with a slight wind during heating even though set to "strong wind" or "weak wind."



A2 At the first of the heating, the product will run for 30 seconds with a slight wind. When set to strong wind, the product will begin with a slight wind operation, producing a weak wind for 30 seconds, and then switch to strong wind.

Q3 The product stops during heating even though it is set to "30°C."



A3 When heating is conducted despite the high outdoor temperature, the product may stop to protect its equipment.

Auto-fresh defrost

Q1 During heating, I turned off the product by using the START/STOP button. But the "operation lamp" is blinking and the outdoor unit is running.



A1 The "auto-fresh defrost" should be working. When stopped, the product will check its outdoor unit for dew and, if there is any dew, conduct defrosting and then stop operating.

Automatic operation

Q1 During an automatic run, switching the wind speed selector will not change the wind speed.



A1 The product will switch automatically to automatic wind speed. You cannot select strong or weak wind by remote control but you can select wind and quiet.

Q2 How is the automatic operation mode determined?



A2 According to the room temperature, heating or cooling operation is automatically selected. Refer to the basic operation section.

Common, etc.

Q1 In "automatic wind speed" mode, the indoor fan changes from strong wind to weak wind to slight wind.



A1 This does not abnormal. It is because the cold wind prevention is working.

In wind speed "automatic" mode, the product will sense the heat exchange temperature and, when the temperature goes down, the product will automatically switch to strong wind to weak wind to slight wind.

Q2 At operation startup, the outdoor unit becomes noisy.



A2 At operation startup, the product will set the rotation speed of the compressor to full power and increase its heating and cooling capacity, resulting in a slightly higher noise level. This is not a sign of a breakdown.

Q3 The outdoor unit sometimes changes in its noise.



A3 The difference between the thermometer temperature setting and room temperature will change the rotation speed of the compressor. This is not a sign of a breakdown.

Q4 There is a difference between the temperature setting and room temperature in room temperature control.



A4 The room structure, air stream, or other factor may cause a gap between the room temperature setting and actual room temperature. If there is any difference between the setting and the room temperature, adjust the temperature setting to match the living space to a comfortable temperature.

Q5 The product will not produce wind right after startup.



A5 After turning ON the power switch or breaker, setting the product to heating or dehumidification will activate a preliminary operation for 1 minute. At that time, heating will cause the operation lamp to blink. This is not a sign of a breakdown.

Q6 I performed internal cleaning, but didn't succeed in controlling the mold in the room.



A6 Internal cleaning will clean the inside of the indoor unit of the air-conditioner, thereby controlling mold generation. This will not control the mold in the room.

Wireless remote control

Q1 The timer will not become set.



A1 Have you set the product to the current time? The timer cannot be set unless it is set to the current time.

Q2 The current time display will disappear at once.



A2 The current time disappears 10 seconds later. The timer set display is given priority.

When set to the current time setting, the reading blinks for about 3 minutes.

Q3 I made a timer "reservation". But the time setting has disappeared.



A3 Is the time not past the reserved time? The set time disappears when the current time reaches the reserved time.

Q4 I tried to set the "sleep" timer while the ON timer is reserved. But it will not set itself to a desired time.



A4 The time set in the "sleep" timer can be set with a time up to the time set with the ON timer. If the end time of the "sleep" timer is past the time set with the ON timer, you cannot make that setting.

Q5 I set the "sleep" timer during operation. But
① the indoor fan will not run (it will not produce wind)
② wind intensity will not change.



A5 ① This occurs when the room temperature and humidity have reached their settings during dehumidification and the air-conditioner is in a pause. The product will begin again to run within about 3 minutes.
② The product will run with the wind speed set to a "quiet" state.

Q6 I tried to change the setting with the "room temperature" button of the remote control unit in vain.



A6 You cannot make this setting when the product is in "air purification" mode. Moreover, you cannot set the product to a desired setting when quick laundry or dew control is being performed with the "auto" or "quick dehumidification" button.

Q7 The temperature setting field on the remote control unit displays $+f^{\circ}\text{C}$ or $-f^{\circ}\text{C}$.



A7 The product will give a display when you operate the product in "auto" using the operation switch button. This can be controlled within the range of $\pm 3^{\circ}\text{C}$.
The product will display $+f^{\circ}\text{C}$ if the temperature is $f^{\circ}\text{C}$ higher than the room temperature in automatic setting.
The product will display $-f^{\circ}\text{C}$ if the temperature is $f^{\circ}\text{C}$ lower than the room temperature in automatic setting.

Q8 The remote control unit will give no display in response to a push of the "vertical vane" button.



A8 The remote control unit displays nothing.

TROUBLE SHOOTING

MODEL RAC-18/25/35/50WEB,

Inspection instructions



Warning

Note that the 0 V line of the outdoor electrical parts and the primary power circuit of the indoor electrical parts have voltages to ground as illustrated in the right-hand figure.

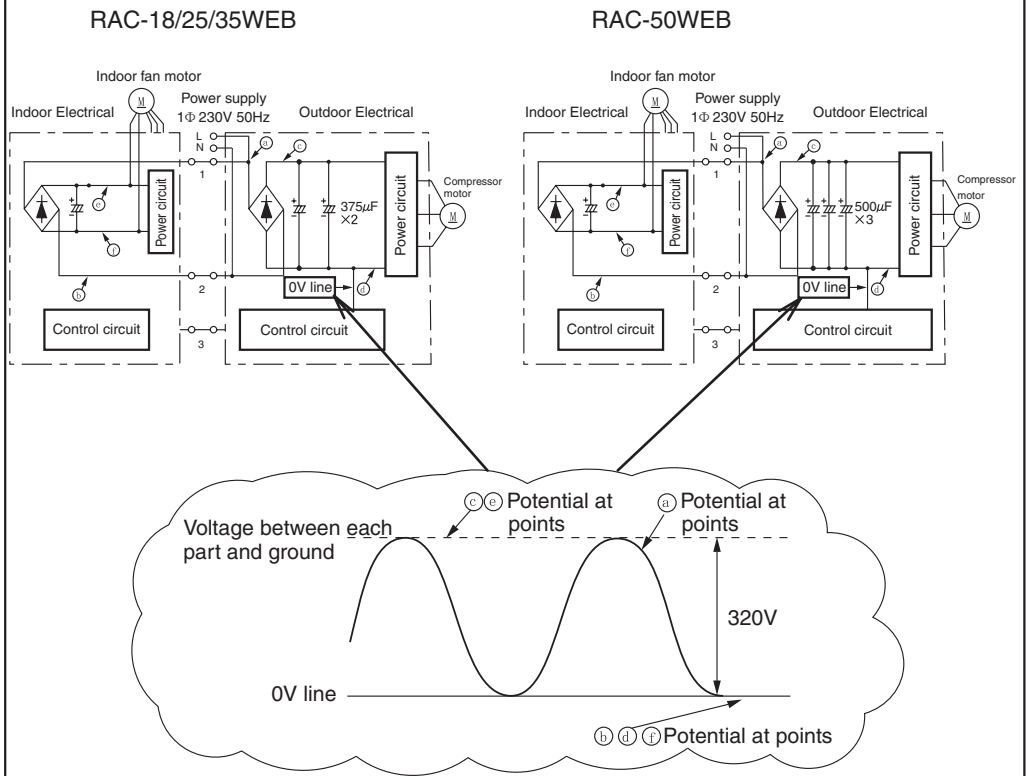

Warning

When conducting a check with an oscilloscope or something similar, do not ground the oscilloscope. Note that the oscilloscope will be subjected to voltages as illustrated in the figure above.

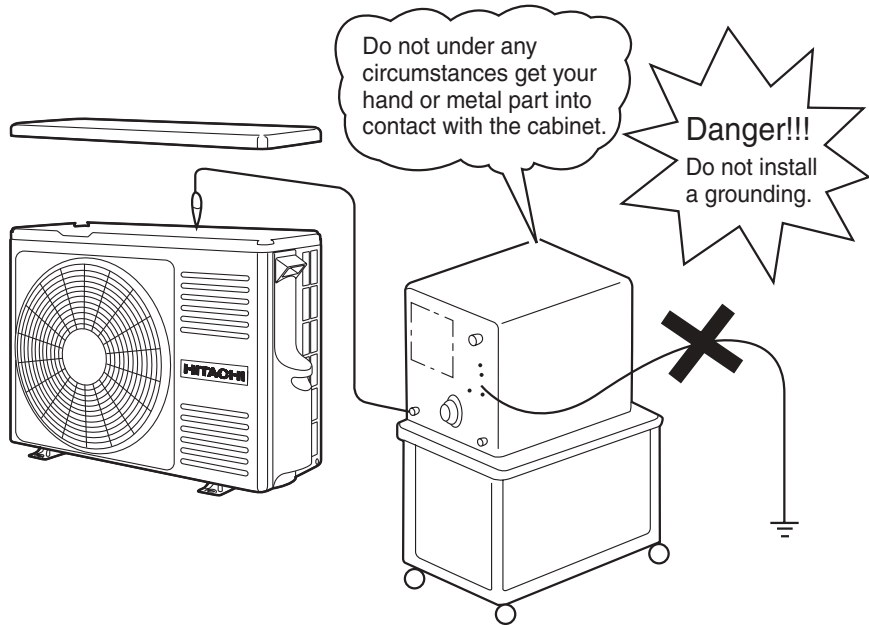

DISCHARGE, PROCEDURE AND POWER SHUT OFF METHOD FOR POWER CIRCUIT



WARNING



Caution

- Voltage of about 350 V is charged between the terminal of smoothing capacitors.
- During continuity check for each circuit part of the outdoor unit, be sure to discharge the smoothing capacitors.

Discharge Procedure

1. Turn off the power.
2. After power is turned off, wait for 10 minutes or more. Then, remove electrical parts cover and apply soldering iron of 30 to 75 W for 15 seconds or more to IPM(24) and IPM(20) terminals on the main P.W.B. as shown in the figure below, in order to discharge voltage in smoothing capacitor.

Do not use a soldering iron with transformer: Otherwise, thermal fuse inside transformer will be blown.

RAC-18/25/35WEB

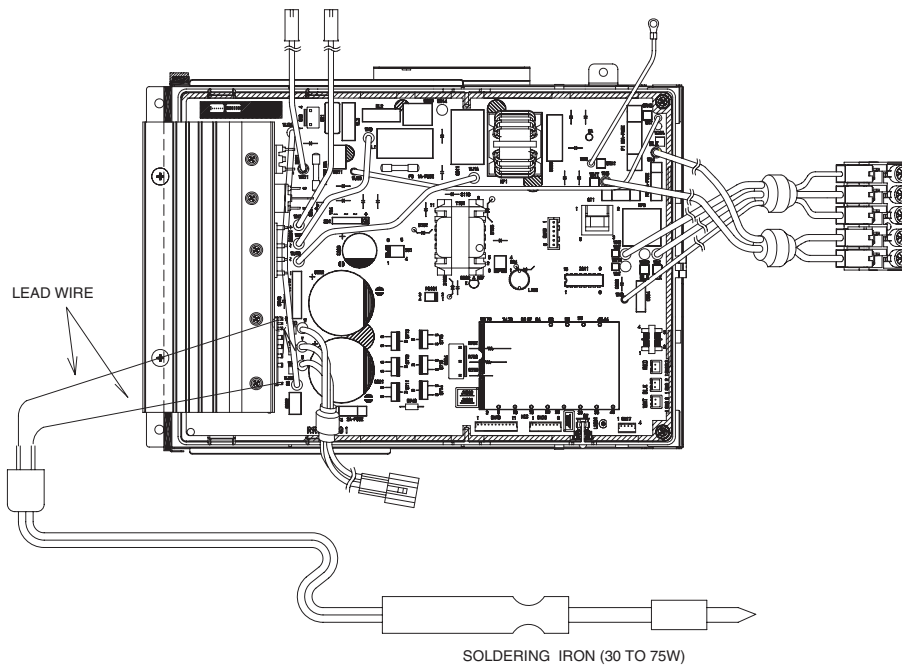

RAC-50WEB

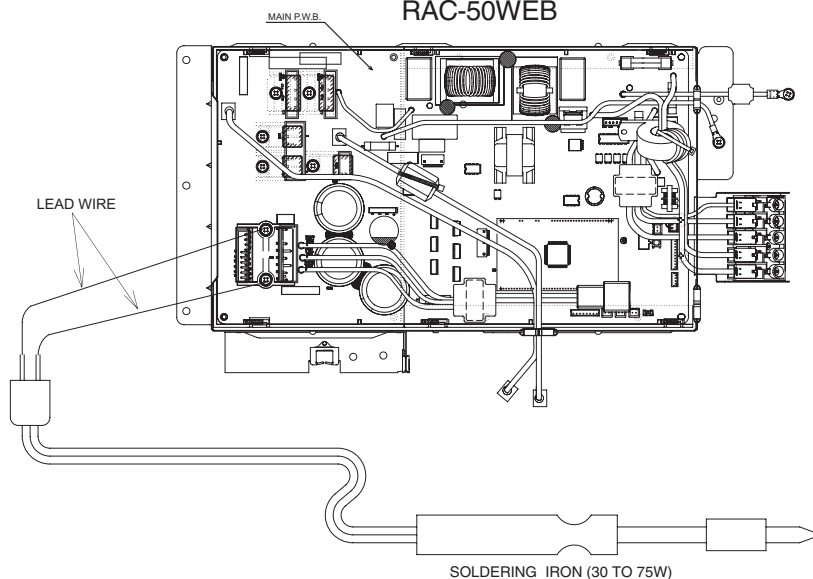

STRUCTURE OF AN INDOOR UNIT ELECTRIC PARTS

RAK-18/25/35/50PEB RAK-25/35/50PEBC

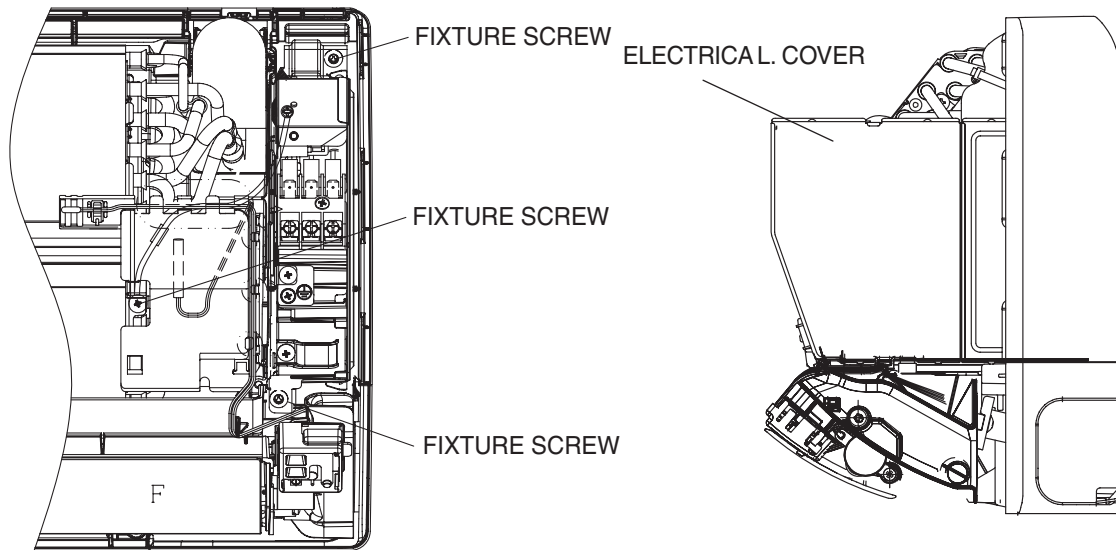

Removing electrical parts

1. Remove the electrical parts cover.
2. Remove the connectors from the CN4 (heat exchange thermistor), CN15 (stepping motor) and CN2 (fan motor).
3. Remove three lock screws.

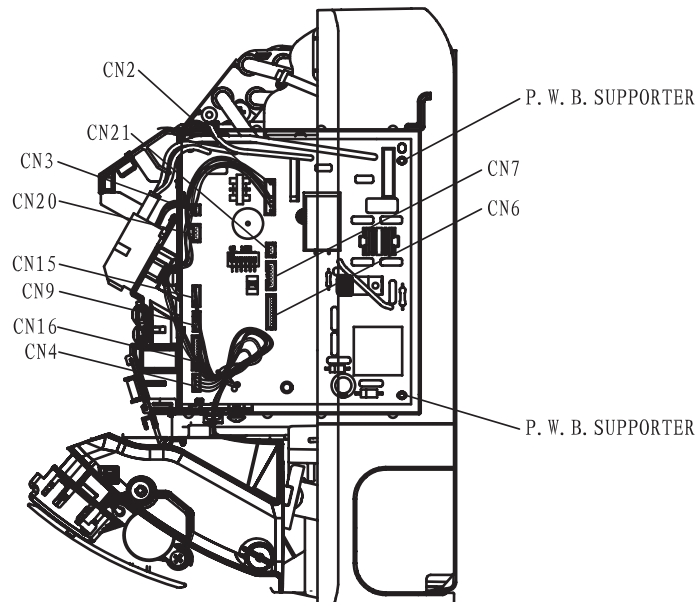

Removing control P.W.B.

1. Remove the connectors from the CN3.
2. Remove the P.W.B. from the P.W.B. support.

Removing the indicating P.W.B.

1. Remove the connector from the CN16 on the control P.W.B.
2. Remove the upper hook from the indicating P.W.B. lock resin, pull the P.W.B. forward a little and remove it.

Other instructions

(1) Detaching and reattaching the receptacles for tab terminal

All the receptacles for connecting tab terminals are with a locking mechanism. Forcibly pulling any such receptacle without unlocking it will destroy it. Be on guard.

When reconnecting it, insert it securely all the way home.

· Receptacle types and how to unlock them

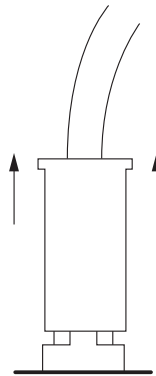

Vertical (with a resin case)

Hold the resin case and pull it out.

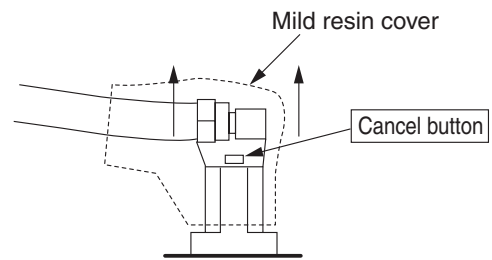

Horizontal (with a mild resin cover)

Hold the cancel button down on the mild resin cover while pulling it out.

(2) Detaching and reattaching the board connector

The product comes equipped with many board connectors provided with lock mechanism. Forcibly pulling any such part without unlocking it will destroy it. Be on guard. When reconnecting it, insert it securely all the way home.

Pinch the locking mechanism with your fingers and pull it out unlocked.

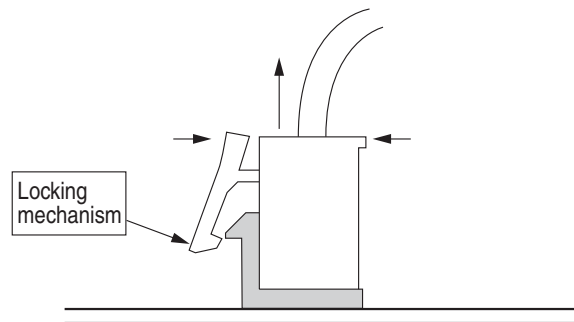

(3) Do not detach or reattach the connectors while energized

Do not under any circumstances detach or reattach the connectors while energized. That would destroy the board components and fan motor. For both the indoor and outdoor boards, ensure that the smoothing capacitor has discharged its electricity fully before you do your work.

No	Function	Description
1	Self-diagnosis display [Display on the indoor unit side]	<ul style="list-style-type: none"> · The failure mode detected on the indoor unit side is displayed by blinking the "timer lamp". And a failure detected on the outdoor unit side will be indicated by the "time lamp" blinking 4 times. · If the outdoor unit side detects a failure, the product will first conduct several operation retrials. There are some failure modes with no lamp display while retrials are continued. <p>[Failure mode where retrials are continued and the indoor unit lamp does not end up giving a display]</p> <ul style="list-style-type: none"> OH thermistor heat-up Overload lower limit cut Low-frequency things
	[Display on the outdoor unit side]	<ul style="list-style-type: none"> · The failure mode detected on the outdoor unit side is displayed by blinking the "LD301". Detecting a failure will stop the outdoor unit and keep blinking the LD301 until it is restarted. (The communication error will persist until the communication is reestablished.)
2	Self-diagnosis memory	<ul style="list-style-type: none"> · The failure modes detected on the indoor and outdoor unit sides are stored in the nonvolatile memory of the indoor unit and can be read later on. (The memory will remain even after power-off.) · The failure modes detected on the outdoor unit side are written in memory every time any such mode occurs. The failure mode can therefore be detected on the indoor unit side without waiting for the retry frequency to reach the display of the indoor unit lamp. Moreover, the normal self-diagnosis display function which rarely occurs will store and display failure modes that do not end up displaying the indoor unit lamp. (Any such mode may be unable to be stored if indoor or outdoor communications is in a failure.) · The product stores 5 last-stored failure modes. · There is a function for deleting memory. Once you clear the memory and run the product for several days, you can read the failure modes and check them, thereby detecting the less frequent failure phenomena. · Failure modes can be checked by both the blinking of the lamp of the indoor unit and the display of the remote control liquid crystal display.

※The "self-diagnosis function of the communication circuit" available in our conventional models is now incorporated as part of the normal self-diagnosis function. In the case of a failure in the communication circuit, you do not have to conduct a special operation and the operations can be automatically divided into 3 blinking operations and 12 blinking operations of the timer lamp. However, a strong external noise may have resulted in 12 times of blinking.

Self-diagnosis display function (indoor side display)

While the "timer lamp" (orange), of the indoor unit is blinking, troubleshoot the product while referring to the table below.

- How to count the lamp blinking frequency
 - The product will repeat blinking with 2-second intermissions.
 - The blinking speed is as follows: on for 0.35 seconds and off for 0.35 seconds.

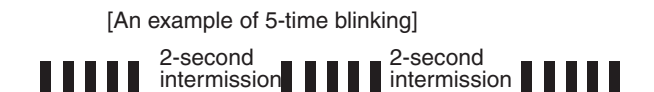

- If you wish to try another operation while the lamp is blinking, operate the START/STOP button on the remote control unit twice. The first push will reset the indoor microcomputer, while the second will activate the product

DESCRIPTION OF THE SELF-DIAGNOSIS INDICATION

REFER TO THE TABLE BELOW IF THE TIMER INDICATOR (ORANGE) IS BLINKING.

LAMP BLINKING MODE	MAIN DEFECTIVE
■ 2 sec ■ — — — — ONCE	REFRIGERANT CYCLE DEFECTIVE
■ ■ 2 sec ■ — — — — 2 TIMES	FORCED COOLING OPERATION
■ ■ ■ 2 sec ■ — — — 3 TIMES	INTERFACE DEFECTIVE (INDOOR)
■ ■ ■ 2 sec ■ — — — 4 TIMES	OUTDOOR UNIT DEFECTIVE
■ ■ ≪ ■ ■ 2 sec ■ — 9 TIMES	INDOOR THERMISTOR DEFECTIVE
■ ■ ≪ ■ ■ 2 sec ■ — 10 TIMES	ABNORMAL ROTATING NUMBERS OF DC FAN MOTOR
■ ■ ≪ ■ ■ 2 sec ■ — 12 TIMES	INTERFACE DEFECTIVE (OUTDOOR)
■ ■ ≪ ■ ■ 2 sec ■ — 13 TIMES	IC531 DEFECTIVE

(■ — — LIGHTS FOR 0.35 SEC AT INTERVAL OF 0.35 SEC.)

* IF THE INTERFACE CIRCUIT IS DEFECTIVE WHEN THE POWER IS TURNED ON,

THE SELF-DIAGNOSIS INDICATION WILL NOT WORK.

* IF THE INDOOR UNIT CAN NOT BE OPERATED AT ALL,

REFER TO THE TABLE BELOW IF THE INDOOR UNIT DOES NOT WORK AT ALL.

CHECK POINT	ACTION/REPLACEMENT PARTS, etc
FU1 (3.15A) FUSE BLOWN	REPLACE THE PART WHICH CAUSED BLOWING /DISCONNECTION OF FU1 (3.15A) FUSE
COME OFF OR DISCONNECTION OF THE CONNECTOR FOR INDICATING P.W.B	FIX CN16 CONNECTOR
FAILURE OF CONTROL P.W.B	REFER TO THE SERVICE GUIDE FOR HOW TO DETERMINE THE FAILED PART

SELF-DIAGNOSIS LIGHTING MODE

MODEL RAC-18/25/35WEB

⚠ ⚡ DANGER (DC350V)

● CUT THE POWER SOURCE AND WAIT MORE THAN 10 MINUTES BEFORE SERVICE WORK.

● CONFIRM THE DC VOLTAGE AT THE MEASURING POINT SHOWN IN BELOW FIGURE MUST BE LESS THAN 10V.

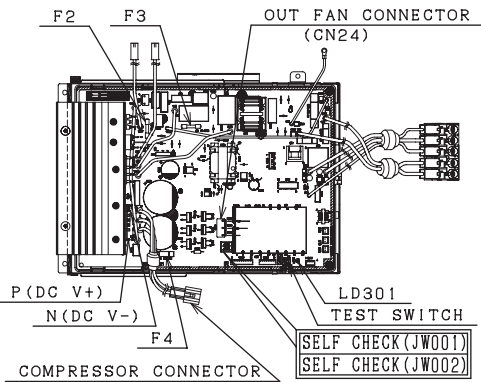

※OTHERS CHECK POINTS

1. DIAGNOSIS FOR [REVERSING VALVE OPERATION ERROR] ;
→CHECK REVERSING VALVE WIRE CONNECTION EITHER WIRE BROKEN OR NOT, IF OK CHECK 3.15A FUSE, IF BROKEN REPLACE FUSE.
2. [WHEN DISPLAY THE COMMUNICATION ERROR OR THE OUTDOOR DO NOT RUN AT ALL],
→PLEASE CHECK THE CONTINUITY OF THE INDOOR ↔ OUTDOOR CONNECTING CORD (F CABLE).

【OUTDOOR FAN MOTOR CHECK】DIAGNOSIS METHOD

1. PUT THE POWER OFF.
 2. REMOVE THE OUTDOOR FAN MOTOR'S CONNECTOR FROM CN24.
 3. ROTATE THE FAN MOTOR BY HAND AND CHECK WHETHER THE FAN MOTOR IS LOCKED OR NOT.
 4. MEASURE THE RESISTANCE BETWEEN EACH TERMINAL OF THE FAN MOTOR CONNECTOR.
NORMAL RESISTANCE BETWEEN EACH TERMINAL: 20~50Ω
- ※INSERT THE FAN MOTOR'S CONNECTOR AFTER FINISHING STEPS 1 TO 4.

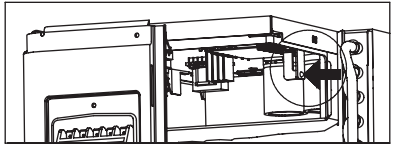

RIGHT SIDE ARROW INDICATE THE POSSITION OF TEST SWITCH LEVER ON THE SIDE PANEL (SHOWN IN LEFT FIGURE,)



DURING STOP	
LD301 LIGHT	CONTENTS
2 SEC LIGHTING AND 0.3 SEC LIGHTS OUT REPETITION	NORMAL OPERATION OVERLOAD OPERATION (NORMAL OPERATION)

IN CASE OF DIFFICULT TO JUDGE THE ABNORMAL WITH ODU CONTROLLER OR THE COMP., BLINKING IN 2, 3, 4 OR 5 TIMES AT SELF-DIAGNOSIS IN THE STOPPING STATUS, PLEASE PERFORM THE MEGA CHECK AND CONFIRM THE INSULATION WITH THE COMPRESSOR, AS THERE IS NOT ABNORMAL FOR THE INSULATION WITH COMPRESSOR, PLEASE PERFORM [SELF-CHECK].

- ### 【SELF-CHECK】DIAGNOSIS METHOD
1. PUT THE POWER OFF.
 2. CUTTING [JW001] BY NIPPER OR BEING SHORT CIRCUIT BETWEEN [JW001] AND [JW002] (FASTEN TOGETHER WITH A CLIP).
 3. PUT THE POWER ON AND OPERATE INDOOR UNIT WITH VENTILATION MODE.
 4. PRESS TEST/SERVICE SWITCH FOR 1 SECOND OR MORE (WITHIN 3 MINUTES).
 5. SELF-CHECK RESULT WILL DISPLAY AT LD301. SEE THE ABOVE TABLE (【SELF-CHECK】DIAGNOSIS RESULT) FOR THE DETAIL.
 6. PUT THE POWER OFF, THEN RELEASE BACK JW001 AND JW002 TO ORIGINAL CONDITION (NO SHORT CIRCUIT CONDITION).
- ※IF FORGET TO RELEASE BACK JW001 AND JW002, THE TIMER LAMP OF THE INDOOR UNIT BLINKS 12 TIMES.

【SELF-CHECK】DIAGNOSIS RESULT		
SELF-DIAGNOSIS BLINKING MODE <input checked="" type="checkbox"/> :BLINK <input type="checkbox"/> :OFF		
LD301 (RED)	SELF-DIAGNOSIS CONTENTS	HOW TO REPAIR
<input checked="" type="checkbox"/>	NOT CONTROLLER DEFECTIVE	•CHANGE THE COMPRESSOR
<input checked="" type="checkbox"/>	FOUND PEAK CURRENT ERROR	•CHANGE ODU CONTROLLER
<input checked="" type="checkbox"/>	COMPRESSOR CURRENT ABNORMAL	•CHECK THE COMPRESSOR CONNECTOR AND CONNECT IT PROPERLY •IF ABOVE ARE OK, CHANGE THE ODU CONTROLLER
<input checked="" type="checkbox"/>	ABNORMAL DC VOLTAGE	•REACTOR IS DISCONNECTION, →CONNECT IT PROPERLY •IF AC VOLTAGE INPUT ABNORMAL (OVER STANDARD VOLTAGE±10%) →FOLLOW STANDARD AC VOLTAGE INPUT •IF AC VOLTAGE INPUT IS NORMAL (WITHIN±10%) →CHANGE P, W, B
<input checked="" type="checkbox"/>	EEPROM READING ERROR	•CHANGE ODU CONTROLLER

DURING STOP			
SELF-DIAGNOSIS BLINKING MODE <input checked="" type="checkbox"/> :BLINK <input type="checkbox"/> :OFF			
LD301 (RED)	SELF DIAGNOSIS CONTENTS	MAIN CHECK POINT	HOW TO REPAIR
<input type="checkbox"/>	NORMAL STOP (STOPPED BY INDOOR THERMOSTAT OR MAIN OPERATION OFF)	1. NO NEED TO CHECK	1. NOT ANY MALFUNCTION
<input checked="" type="checkbox"/>	FAN MODE OPERATION, RESET STOP	1. INDOOR AIR CLEAN OPERATION	1. NOT ANY MALFUNCTION
<input checked="" type="checkbox"/>	PEAK CURRENT CUT	2. OTHER CAUSE	2. CHANGE ODU CONTROLLER
2 TIMES	ABNORMAL LOW SPEED ROTATION	1. ODU CONTROLLER DEFECTIVE 2. COMPRESSOR ABNORMAL LOAD	1. CHANGE ODU CONTROLLER 2. CHECK THE COMPRESSOR
3 TIMES	SWITCHING FAILURE	1. COMPRESSOR CONNECTOR OPEN 2. COMPRESSOR ABNORMAL LOAD 3. ODU CONTROLLER DEFECTIVE	1. INSERT THE CONNECTOR 2. CHECK THE COMPRESSOR 3. CHANGE ODU CONTROLLER
4 TIMES	OVERLOAD LOWER LIMIT CUT	1. OBSTACLE SURROUND THE ODU MAY CAUSE 2. OTHER CAUSE	1. REMOVE THE OBSTRUCTION 2. CHECK CYCLE PIPE
5 TIMES	OH THERMISTOR TEMPERATURE RISE	1. DUE TO OPEN CONNECTOR 2. LEAKAGE OF REFRIGERANT 3. OTHER CAUSE	1. INSERT THE CONNECTOR 2. CHECK THE CYCLE PIPE AND RECHARGE THE REFRIGERANT 3. CHANGE ODU CONTROLLER
6 TIMES	THERMISTOR ABNORMAL	1. CONNECTOR INSERT MISS 2. OPEN CIRCUIT/SHORT CIRCUIT OF THERMISTOR WIRE 3. ODU CONTROLLER DEFECTIVE	1. INSERT PROPERLY 2. CHANGE THE THERMISTOR 3. CHANGE ODU CONTROLLER
7 TIMES	COMMUNICATIONS ERROR	1. F CABLE MISS CONNECTION 2. F CABLE DISCONNECTION 3. ODU CONTROLLER DEFECTIVE	1. F CABLE CONNECT PROPERLY 2. CHANGE THE F CABLE 3. CHANGE ODU CONTROLLER
9 TIMES	ABNORMAL POWER SOURCE	1. REACTOR IS UNCONNECTED 2. ABNORMAL AC INPUT: OUT OF THE RANGE (230±10%) 3. AC INPUT IS NORMAL	1. CONNECT REACTOR PROPERLY 2. CONNECT TO NORMAL AC POWER SOURCE 3. CHANGE ODU CONTROLLER
10 TIMES	ODU FAN STOP BY STRONG REVERSE WIND	1. OUTDOOR FAN STOP BY STRONG REVERSE WIND	1. IT WILL RE-START AFTER THE WIND BECOME WEAK
11 TIMES	OUTDOOR FAN LOCK ERROR	1. OUTDOOR FAN STOP BY STRONG REVERSE WIND 2. PROPELLER FAN LOCK 3. OUTDOOR FAN MOTOR LOCK 4. OUTDOOR FAN MOTOR OK	1. AUTOMATICALLY RE-START AFTER WIND BECOME WEAK 2. REMOVE THE OBSTRUCTION 3. CHANGE THE FAN MOTOR 4. CHANGE ODU CONTROLLER
12 TIMES	EEPROM READ ERROR	•CHANGE OUTDOOR UNIT CONTROLLER	
13 TIMES	ACTIVE VOLTAGE ABNORMAL	1. ABNORMAL OUTDOOR 2. ABNORMAL COMPRESSOR LOAD	1. CHANGE ODU CONTROLLER 2. CHECK THE COMPRESSOR
14 TIMES	HIGH LOAD STOP	1. SERVICE VALVE CLOSE 2. OBSTACLE SURROUND THE ODU UNIT MAY CAUSE 3. CLOGGED FILTER IN INDOOR UNIT CAUSE.	1. CHECK SERVICE VALVE 2. REMOVE THE OBSTRUCTION 3. CHECK FILTER
16 TIMES			

SELF-DIAGNOSIS LIGHTING MODE

MODEL RAC-50WEB

⚠ DANGER (DC350V)

- CUT THE POWER SOURCE AND WAIT MORE THAN 10 MINUTES BEFORE SERVICE WORK.
- CONFIRM THE DC VOLTAGE AT THE MEASURING POINT SHOWN IN BELOW FIGURE MUST BE LESS THAN 10V.

DURING STOP	
LD301	CONTENTS
LIGHT	NORMAL OPERATION
2 SEC LIGHTING AND 0.3 SEC LIGHTS OUT REPETITION	OVERLOAD OPERATION(NORMAL OPERATION)

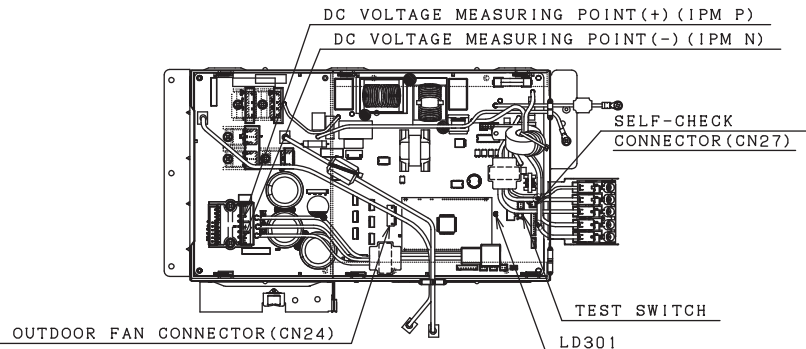

DURING STOP

SELF-DIAGNOSIS BLINKING MODE :BLINK :OFF

LD301 (RED)	SELF DIAGNOSIS CONTENTS	MAIN CHECK POINT	HOW TO REPAIR
<input type="checkbox"/>	NORMAL STOP (STOPPED BY INDOOR THERMOSTAT OR MAIN OPERATION OFF)	1. NO NEED TO CHECK	1. NOT ANY MALFUNCTION
<input checked="" type="checkbox"/>	FAN MODE OPERATION, RESET STOP	1. INDOOR AIR CLEAN OPERATION	1. NOT ANY MALFUNCTION
<input checked="" type="checkbox"/>	PEAK CURRENT CUT	1. ODU CONTROLLER DEFECTIVE 2. COMPRESSOR ABNORMAL LOAD	1. CHANGE ODU CONTROLLER 2. CHECK THE COMPRESSOR
<input checked="" type="checkbox"/>	ABNORMAL LOW SPEED ROTATION	1. ODU CONTROLLER DEFECTIVE 2. COMPRESSOR ABNORMAL LOAD	1. CHANGE ODU CONTROLLER 2. CHECK THE COMPRESSOR
<input checked="" type="checkbox"/>	SWITCHING FAILURE	1. COMPRESSOR CONNECTOR OPEN 2. COMPRESSOR ABNORMAL LOAD 3. ODU CONTROLLER DEFECTIVE	1. INSERT THE CONNECTOR 2. CHECK THE COMPRESSOR 3. CHANGE ODU CONTROLLER
<input checked="" type="checkbox"/>	OVERLOAD LOWER LIMIT CUT	1. OBSTACLE SURROUND THE ODU MAY CAUSE 2. OTHER CAUSE	1. REMOVE THE OBSTRUCTION 2. CHECK CYCLE PIPE
<input checked="" type="checkbox"/>	OH THERMISTOR TEMPERATURE RISE	1. DUE TO OPEN CONNECTOR 2. LEAKAGE OF REFRIGERANT 3. OTHER CAUSE	1. INSERT THE CONNECTOR 2. CHECK THE CYCLE PIPE AND RECHARGE THE REFRIGERANT 3. CHANGE ODU CONTROLLER
<input checked="" type="checkbox"/>	THERMISTOR ABNORMAL	1. CONNECTOR INSERT MISS 2. OPEN CIRCUIT/SHORT CIRCUIT OF THERMISTOR WIRE 3. ODU CONTROLLER DEFECTIVE	1. INSERT PROPERLY 2. CHANGE THE THERMISTOR 3. CHANGE ODU CONTROLLER
<input checked="" type="checkbox"/>	COMMUNICATIONS ERROR	1. F CABLE MISS CONNECTION 2. F CABLE DISCONNECTION 3. ODU CONTROLLER DEFECTIVE	1. F CABLE CONNECT PROPERLY 2. CHANGE THE F CABLE 3. CHANGE ODU CONTROLLER
<input checked="" type="checkbox"/>	ABNORMAL POWER SOURCE	1. REACTOR IS UNCONNECTED 2. ABNORMAL AC INPUT: OUT OF THE RANGE (230±10%) 3. AC INPUT IS NORMAL	1. CONNECT REACTOR PROPERLY 2. CONNECT TO NORMAL AC POWER SOURCE 3. CHANGE ODU CONTROLLER
<input checked="" type="checkbox"/>	ODU FAN STOP BY STRONG REVERSE WIND	1. OUTDOOR FAN STOP BY STRONG REVERSE WIND	1. IT WILL RE-START AFTER THE WIND BECOME WEAK
<input checked="" type="checkbox"/>	OUTDOOR FAN LOCK ERROR	1. OUTDOOR FAN STOP BY STRONG REVERSE WIND 2. PROPELLER FAN LOCK 3. OUTDOOR FAN MOTOR LOCK 4. OUTDOOR FAN MOTOR OK	1. AUTOMATICALLY RE-START AFTER WIND BECOME WEAK 2. REMOVE THE OBSTRUCTION 3. CHANGE THE FAN MOTOR 4. CHANGE ODU CONTROLLER
<input checked="" type="checkbox"/>	EEPROM READ ERROR		• CHANGE OUTDOOR UNIT CONTROLLER
<input checked="" type="checkbox"/>	ACTIVE VOLTAGE ABNORMAL	1. ABNORMAL OUTDOOR CONTROLLER 2. ABNORMAL COMPRESSOR LOAD	1. CHANGE ODU CONTROLLER 2. CHECK THE COMPRESSOR
<input checked="" type="checkbox"/>	CIRCUIT ABNORMAL		• CHANGE OUTDOOR UNIT CONTROLLER
<input checked="" type="checkbox"/>	HIGH LOAD STOP	1. SERVICE VALVE CLOSE 2. OBSTACLE SURROUND 3. CLOGGED FILTER IN INDOOR UNIT CAUSE.	1. CHECK SERVICE VALVE 2. REMOVE THE OBSTRUCTION 3. CHECK FILTER

※EXAMPLE OF BLINKING (5TIMES) () ODU:OUTDOOR UNIT OF 0.25 SEC.

IN CASE OF DIFFICULT TO JUDGE THE ABNORMAL WITH ODU CONTROLLER OR THE COMP., BLINKING IN 2, 3, 4 OR 5 TIMES AT SELF-DIAGNOSIS IN THE STOPPING STATUS, PLEASE PERFORM THE MEGA CHECK AND CONFIRM THE INSULATION WITH THE COMPRESSOR. AS THERE IS NOT ABNORMAL FOR THE INSULATION WITH COMPRESSOR, PLEASE PERFORM [SELF-CHECK].

[SELF-CHECK] DIAGNOSIS METHOD

1. PUT THE POWER OFF.
2. REMOVE THE SELF-CHECK CONNECTOR*CN27*.
3. PUT THE POWER ON.
4. (LD301: 4 SEC LIGHTING AND 2 SEC LIGHTS OUT).
5. PUSH [TEST SWITCH] DURING 1 SEC OR MORE.
6. [SELF-CHECK] DIAGNOSIS RESULT WILL DISPLAY AT LD301. SEE THE BELOW TABLE FOR THE DETAIL.

※IF FORGET TO CONNECTING THE *CN27*, THE TIMER LAMP OF THE INDOOR UNIT BLINKS 12 TIMES.

[SELF-CHECK] DIAGNOSIS RESULT

SELF-DIAGNOSIS BLINKING MODE :BLINK

LD301 (RED)	SELF-DIAGNOSIS CONTENTS	HOW TO REPAIR
<input checked="" type="checkbox"/>	NOT CONTROLLER DEFECTIVE	• CHANGE THE COMPRESSOR
<input checked="" type="checkbox"/>	FOUND PEAK CURRENT ERROR	• CHANGE ODU CONTROLLER
<input checked="" type="checkbox"/>	COMPRESSOR CURRENT ABNORMAL	• CHECK THE COMPRESSOR CONNECTOR AND CONNECT IT PROPERLY • IF ABOVE ARE OK, CHANGE THE ODU CONTROLLER
<input checked="" type="checkbox"/>	ABNORMAL DC VOLTAGE	• REACTOR IS DISCONNECTION, → CONNECT IT PROPERLY • IF AC VOLTAGE INPUT ABNORMAL (OVER STANDARD VOLTAGE±10%) → FOLLOW STANDARD AC VOLTAGE INPUT • IF AC VOLTAGE INPUT IS NORMAL (WITHIN±10%) → CHANGE P, W, B
<input checked="" type="checkbox"/>	EEPROM READING ERROR	• CHANGE ODU CONTROLLER

[OUTDOOR FAN MOTOR CHECK] DIAGNOSIS METHOD

1. PUT THE POWER OFF.
2. REMOVE THE OUTDOOR FAN MOTOR'S CONNECTOR FROM *CN24*.
3. ROTATE THE FAN MOTOR BY HAND AND CHECK WHETHER THE FAN MOTOR IS LOCKED OR NOT.
4. MEASURE THE RESISTANCE BETWEEN EACH TERMINAL OF THE FAN MOTOR CONNECTOR. NORMAL RESISTANCE BETWEEN EACH TERMINAL: 20~50Ω

※INSERT THE FAN MOTOR'S CONNECTOR AFTER FINISHING STEPS 1 TO 4.

※OTHERS CHECK POINTS

1. DIAGNOSIS FOR [REVERSING VALVE OPERATION ERROR] ;
→ CHECK REVERSING VALVE WIRE CONNECTION EITHER WIRE BROKEN OR NOT, IF OK CHECK 3, 15A FUSE, IF BROKEN REPLACE FUSE
2. [WHEN DISPLAY THE COMMUNICATION ERROR OR THE OUTDOOR DO NOT RUN AT ALL],
→ PLEASE CHECK THE CONTINUITY OF THE INDOOR ↔ OUTDOOR CONNECTING CORD (F CABLE).

Forced cooling operation

The cooling operation can be forcibly performed for collecting refrigerant and inspecting failures. Do not perform the forced cooling operation continuously for long hours, because the compressor continues to be in operational status, regardless of room temperature.

<How to start the operation>

- The operation of the unit should be stopped.
- Press and hold the "Temporary operation SW" shown in the right figure for 5 sec.

<How to stop the operation>

- Press and hold the "Temporary operation SW" again. Or stop the operation using the remote controller.

※During the forced cooling operation, the "Timer indicator" blinks twice.

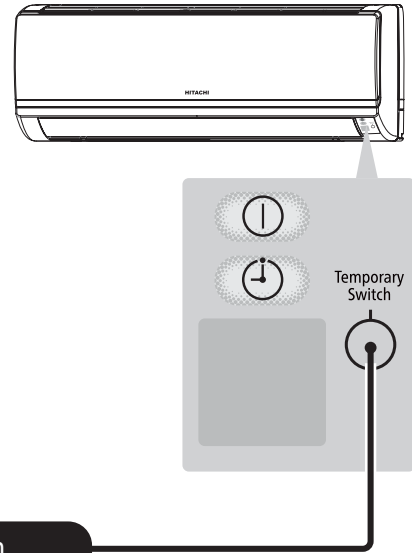

Temporary operation switch

When performing the forced cooling operation, turn the power off once. If you press and hold the switch for 5 sec or longer, the forced cooling operation starts. To stop the forced cooling operation, press the switch once again or stop the operation using the remote controller.

Diagnosis and troubleshooting of indoor electric parts, outdoor electric parts and refrigerating cycle

Initiating troubleshooting

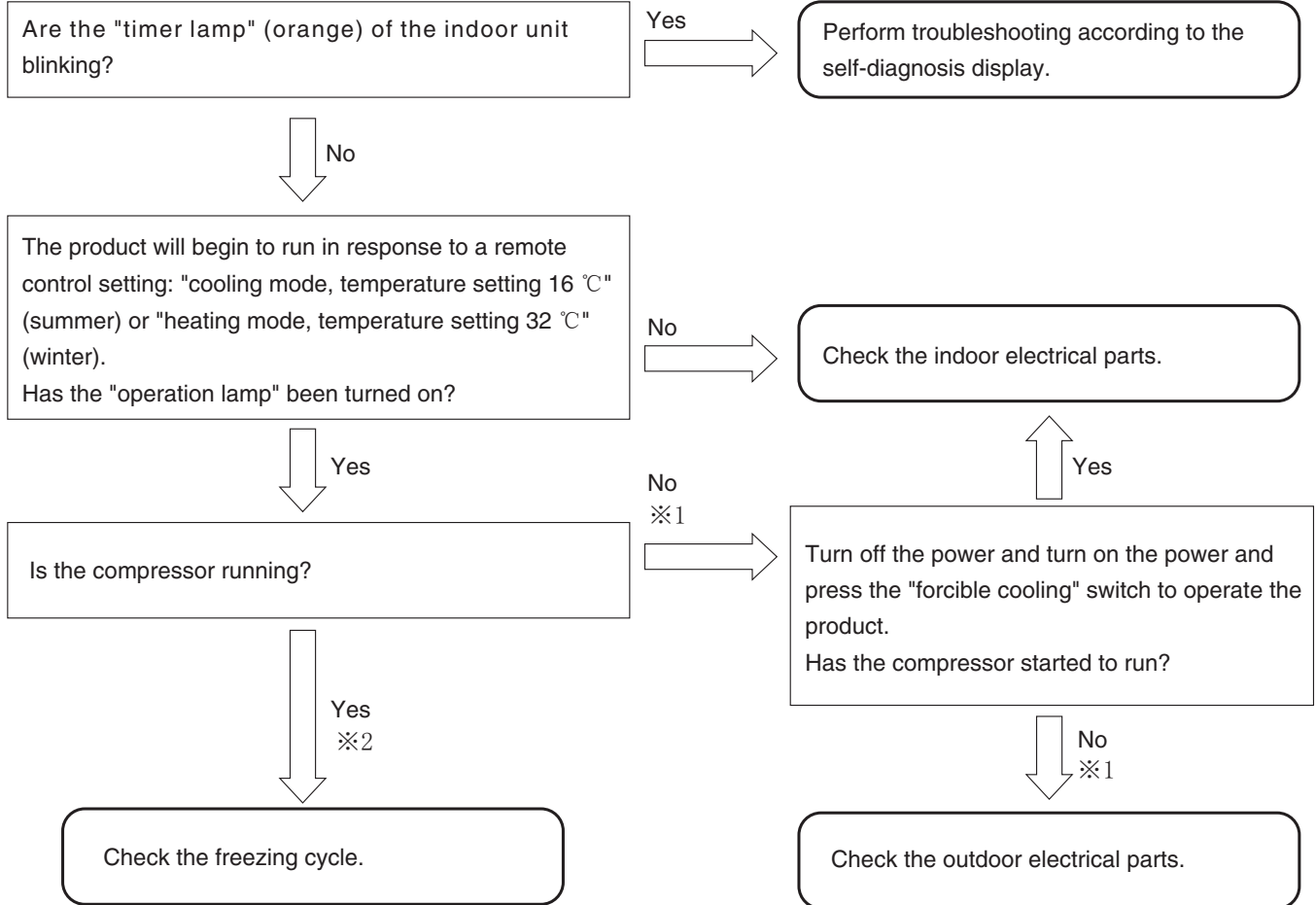

< Troubleshooting by using the self-diagnosis memory function >

- By using the self-diagnosis memory function, you can check the failure mode (※1) occurring in the outdoor electrical parts on the indoor unit side.

- Steps
1. Clear the troubleshooting data.
 2. Run the product for several minutes under the conditions where the compressor runs.
 3. Redisplay and check the data written in the self-diagnosis memory.

- The self-diagnosis memory function can also be used to catch sporadic failure phenomena.

- Steps
1. Clear the troubleshooting data.
 2. Have the user use the product as usual until a failure phenomenon occurs.
(The period depends on the incidence of the phenomenon.)
 3. At a later date, redisplay and check the data written in the self-diagnosis memory.

- For the outdoor self-diagnosis display (OH thermistor heat-up, overload lower limit cut) stemming from the freezing cycle or operating condition, the time lag is long from operation startup to the emergence of the phenomenon. Moreover, it is affected by the temperature, sunshine, operating hours, and other factors of the day, so that the phenomenon may not be able to be identified at the time of a repair service visit. In that case too, use the self-diagnosis memory function (※2).
- The outdoor self-diagnosis display "overload lower limit cut" and "OH thermistor heat-up" can be identified only when you are using the self-diagnosis lamp of the outdoor unit and the self-diagnosis memory function of the indoor unit. Note that this will not be automatically displayed on the indoor unit side.

Checking the indoor unit electrical parts

Introduction

First check the failure phenomenon and status, and then move on to elaborate diagnosis.

Initiating troubleshooting

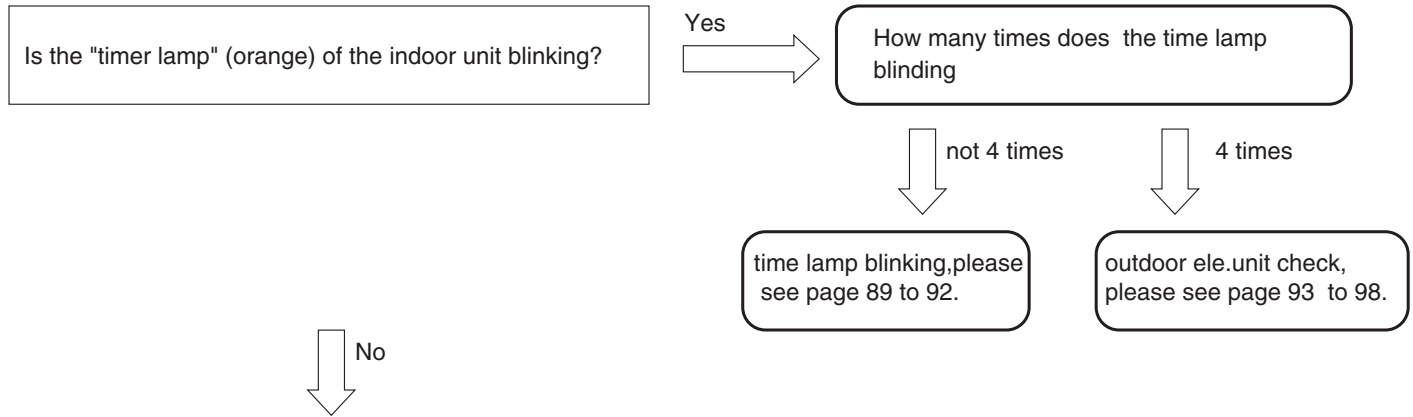

Turn off the power, wait at least 5 seconds, turn it back on, and observe the way the horizontal vanes move for about 30 seconds.

Check 1: Have the horizontal vanes moved? (Yes/No)



Set the remote control unit to cooling mode, temperature setting 16°C (summer), heating mode, temperature setting 32°C (winter) and operate the product.

Check 2: Has the product received the remote control signal and has the "operation lamp" gone on? (Yes/No)

If you responded "Yes" to Check 2:

Check 3: Is the compressor of the outdoor unit running? (Yes/No)

If you responded "No" to Check 2:

Check 4: Does the "emergency operation switch" work? (Yes/No)

Check results and next check items

Check 1	Check 2	Check 3	Check 4	Next check item
No	No	—	No	Go on to "The power will not become turned on".
Yes	No	—	Yes	Go on to "The product will not receive the remote control signal".
Yes	Yes	No	—	Go on to "The compressor will not run".

1. Failure phenomenon: The power will not become turned on.

[Situation] Neither initialization, remote control, nor any other step works on the vane position at power-on.

<p>[Estimated failure locations]</p> <ul style="list-style-type: none"> · 3.15 A fuse blown out · Control power circuit · Connector loose, wire break 	<p>Estimated cause of fuse blowout</p> <ul style="list-style-type: none"> · Abnormally high voltage applied to the power supply · Indoor fan motor out of order · Power circuit out of order
--	---

- [Cautions]
- Before work, check the power supply voltage. An abnormal voltage may be being supplied in some rare occasions due to a defect in the indoor wiring (a wire break in the neutral wire of the single-phase 3-wire power supply).
 - If the 3.15 A fuse has blown out, eliminate the cause of the fuse blowout. Otherwise, there will occur another fuse blowout.
 - If the 3.15 A fuse has blown out due to an abnormally high voltage to the power supply, the varistor (VA001) will deteriorate and become destroyed as well.
 - On a repair service visit due to the failure phenomenon of "The power will not become turned on", take a "3.15 A fuse" and a "varistor" with you.

[Diagnosis flow]

Initiating troubleshooting

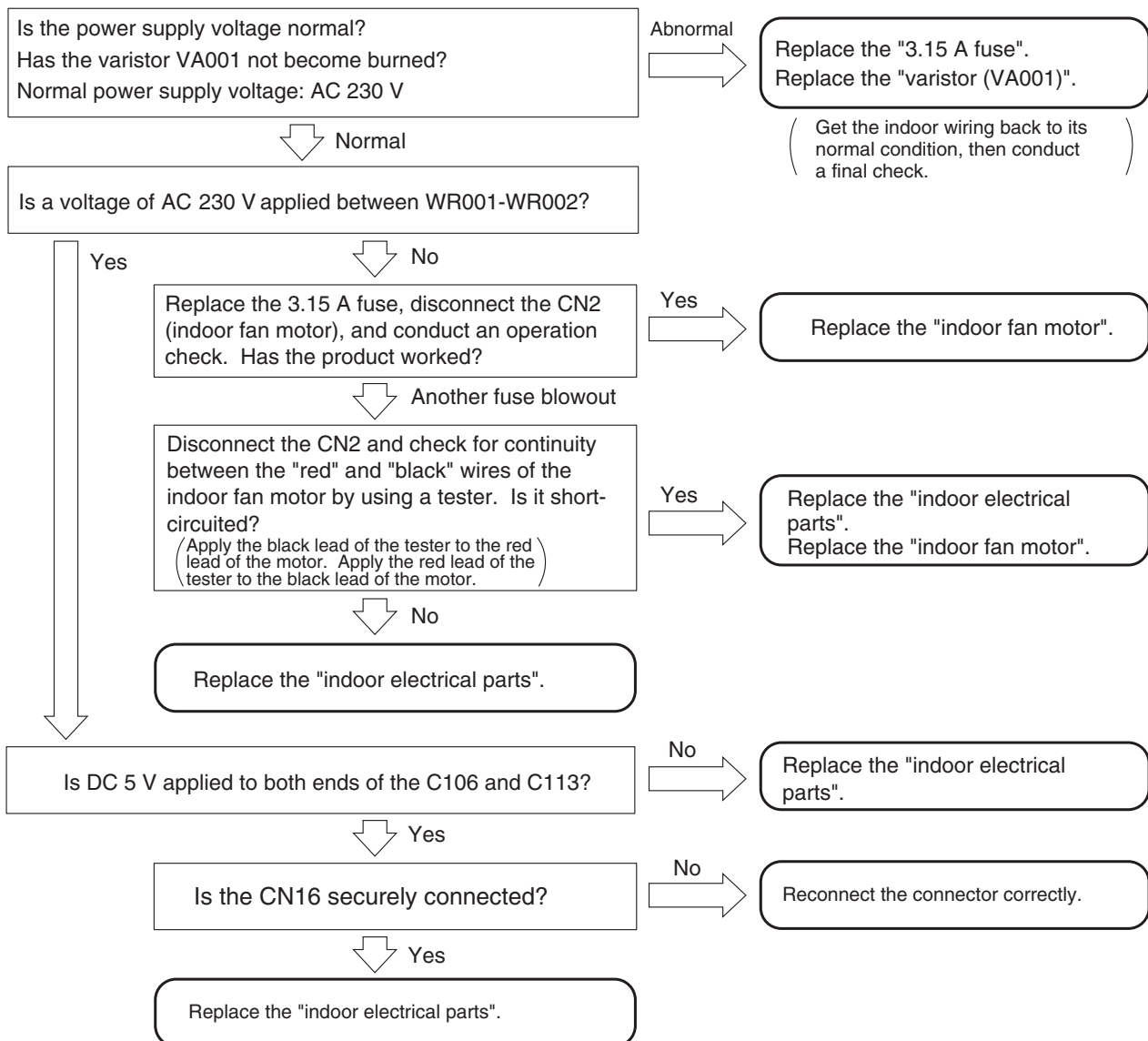

2.Failure phenomenon: The product will not receive a remote control signal.

- [Situation] The product does not receive a remote control signal. It is not very responsive.
(The product does run normally in response to the emergency operation switch.)
- [Estimated failure locations]
- Remote control failure, remote control low battery level, remote control poorly set
 - Remote control light-receiving unit
 - Connector loose, wire break
 - Normal product (external factors: the remote control units for lighting equipment and other equipment, electrical noise, etc.)
- [Cautions]
- Even if the product is trouble-free, a factor coming from outside the product may hamper the reception of signals from the remote control unit.
 - Batteries may decline in capacity at low temperatures. Old batteries decline particularly much in voltage in the morning and evening of winter, resulting in the poor arrival of remote control signals. Instruct your users to use new alkaline batteries.

[Diagnosis flow]

Initiating troubleshooting

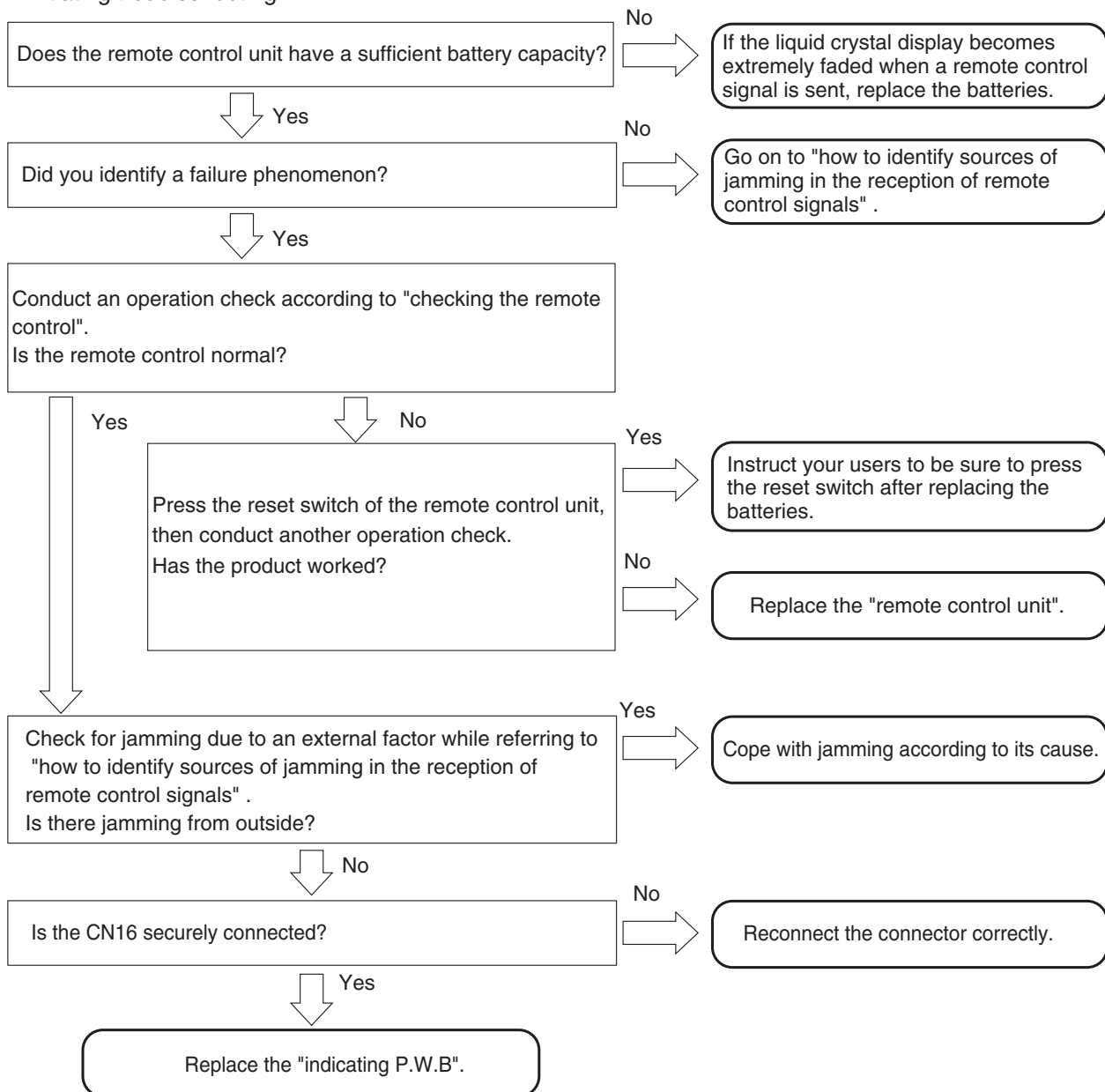

[Cautions in replacing the indicating P.W.B] Be sure to replace the indicating P.W.B. components.

How to identify sources of jamming in the reception of remote control signals

[Situation] The product may become poorly responsive to remote control signals due to external factors even though the product itself is trouble-free.

[Estimating sources of jamming] Identify the installation status of the air-conditioner and the indoor and outdoor environments to identify possible causes of the jamming.

- Indoor lighting equipment (quantity, type, location)
- Remote control units of other electrical products and equipment
- Is the grounding for the air-conditioner shared with other equipment?
- Are the surroundings of the air-conditioner clear of wireless antenna?
- Is the remote control light-receiving unit protected from direct sunlight?

[Checking and actions]

<p>Effects of lighting equipment (fluorescent lamps)</p>	<p><u>Checking points</u></p> <ul style="list-style-type: none"> · Turn on and off the lighting equipment and check for its effects on the reception of remote control signals. · When cold, the fluorescent lamp tends to emit infrared rays with wavelengths close to those used in remote control. <p>If you cannot detect the phenomenon about which your user is complaining at the time of your visit, such as "the product sometimes fails to receive remote control signals" and "the product fails to receive remote control signals in the morning alone", then turn off the lighting for about 20-30 minutes and wait for the fluorescent lamps to cool down before conducting another check.</p> <p>There are even cases where the product fails to receive remote control signals for 1 to 2 minutes only after the lighting equipment is turned on.</p> <ul style="list-style-type: none"> · The noise status may vary with the dimming of the lighting equipment. In the case of lighting equipment with a dimmer, therefore, conduct a check with all the light intensities. · If the lighting equipment is the source of the jamming, the remote control light-receiving unit output usually shows a noise waveform as shown in the right-hand figure. In the case of slight jamming, this kind of waveform will not cause practical problems. However, intense degrees of jamming will disable the reception of remote control signals. · When the fluorescent lamp is old and is flickering, it may cause disorders in the reception of remote control signals. <p><u>Actions proposed</u></p> <ol style="list-style-type: none"> 1. Make it hard for light of the lighting equipment to enter the remote control light-receiving unit. <ul style="list-style-type: none"> · Separate the lighting equipment from the indoor unit. · Raise the lighting equipment. · Cover the upper half of the light-receiving panel from its rear side with aluminum tape or black vinyl tape. <p>(This will also affect the reception of remote control signals. Therefore, set the range to be covered with tape to a range that is problem-free in practice, while checking the reception status.)</p> 2. Add an interference filter to the front panel of the remote control light-receiving unit. <ul style="list-style-type: none"> ※ Lighting equipment that produces strong jamming exists although rarely. Some problems may therefore be unsolvable by managing the air-conditioner side alone.
<p>Effects of the remote control units of other equipment</p>	<p><u>Checking points</u></p> <ul style="list-style-type: none"> · If, on the remote control unit of a TV or audio equipment, its sound volume key or something similar is left pressed, infrared signals become continuously sent, thereby jamming the reception of remote control signals. · Check how the remote control unit and related components are stored, thereby checking if there is any possibility that a button may be inadvertently left pressed on the remote control unit of other equipment. <p><u>Actions proposed</u></p> <p>If there is any such possibility, give explanations to your users to that effect and instruct them to exercise caution.</p>

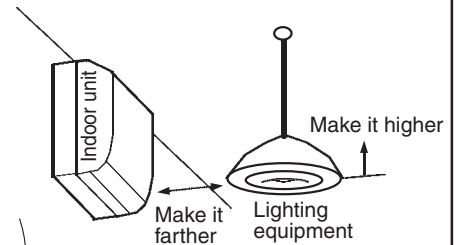
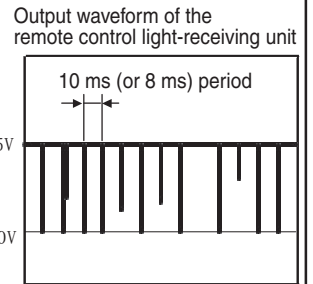

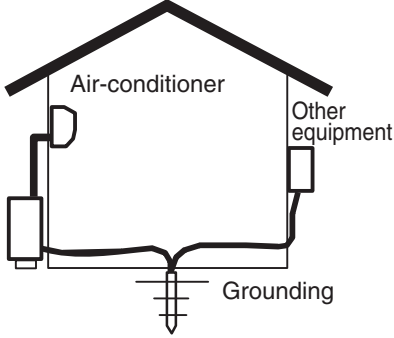
<p>Effects of other electrical products</p>	<p><u>Checking points</u></p> <ul style="list-style-type: none"> · Check the effects of light and power noises coming from other electrical products. · Turn on and off the electrical products, turn off the power and turn on the power, and check their effects on the reception of remote control signals. · For products whose operating states change, check the effects of each state. <p><u>Actions proposed</u></p> <ul style="list-style-type: none"> · Change the location relationship between the air-conditioner and the target products. · Use a different wall outlet for the target products.
<p>Sharing a grounding</p>	<p><u>Checking points</u></p> <ul style="list-style-type: none"> · Check for effects of electrical noises coming into the air-conditioner through grounding wires. · Check if the grounding works is for the air-conditioner alone or shared with other equipment. If there is any equipment that shares it, turn on and off that equipment and detach and reattach the power plugs and examine their effects on the reception of remote control signals. <p><u>Actions proposed</u></p> <ul style="list-style-type: none"> · Establish an independent grounding for the air-conditioner.  <p>The diagram shows a cross-section of a house with a gabled roof. An 'Air-conditioner' is mounted on the left wall, and 'Other equipment' is on the right wall. Both are connected to a single horizontal line representing a shared grounding system. This line leads to a vertical line labeled 'Grounding' which is connected to a ground symbol (three horizontal lines of decreasing width) at the bottom center.</p>
<p>Effects of radio waves</p>	<p><u>Checking points</u></p> <ul style="list-style-type: none"> · Using a wireless transmitter near the air-conditioner may affect the reception of remote control signals. · Have your users try sending signals with a wireless transmitter and examine their effects on the reception of remote control signals. <p><u>Actions proposed</u></p> <ul style="list-style-type: none"> · Add a ferrite core to the power cord and F cable. · Add a ferrite core to the internal wiring of the indoor unit. · Move the wireless antenna.
<p>Effects of direct sunlight</p>	<p><u>Checking points</u></p> <ul style="list-style-type: none"> · Direct sunlight and other intense light make the remote control light-receiving unit less sensitive. · Check for any time zone where the remote control light-receiving unit of the indoor unit is affected by direct sunlight depending on the location of the sun and mirror reflection. <p><u>Actions proposed</u></p> <ul style="list-style-type: none"> · Block the sunlight to protect against direct sunlight.

3. Failure phenomenon: The compressor will not run.

[Situation] The compressor will not run (the same state as the thermometer turned off), the product receives remote control signals normally. The self-diagnosis lamp (LD301) of the outdoor unit blinks once or becomes turned off.

[Estimated failure locations] · Room temperature thermistor, heat exchanger thermistor
· Microcomputer peripheral circuit

[Diagnosis flow]
Initiating troubleshooting

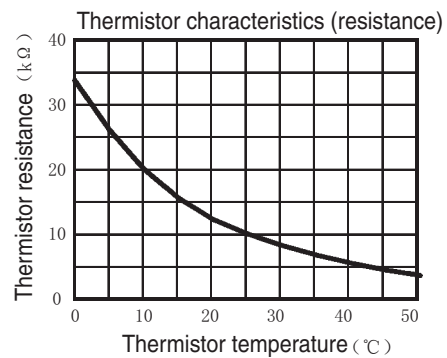
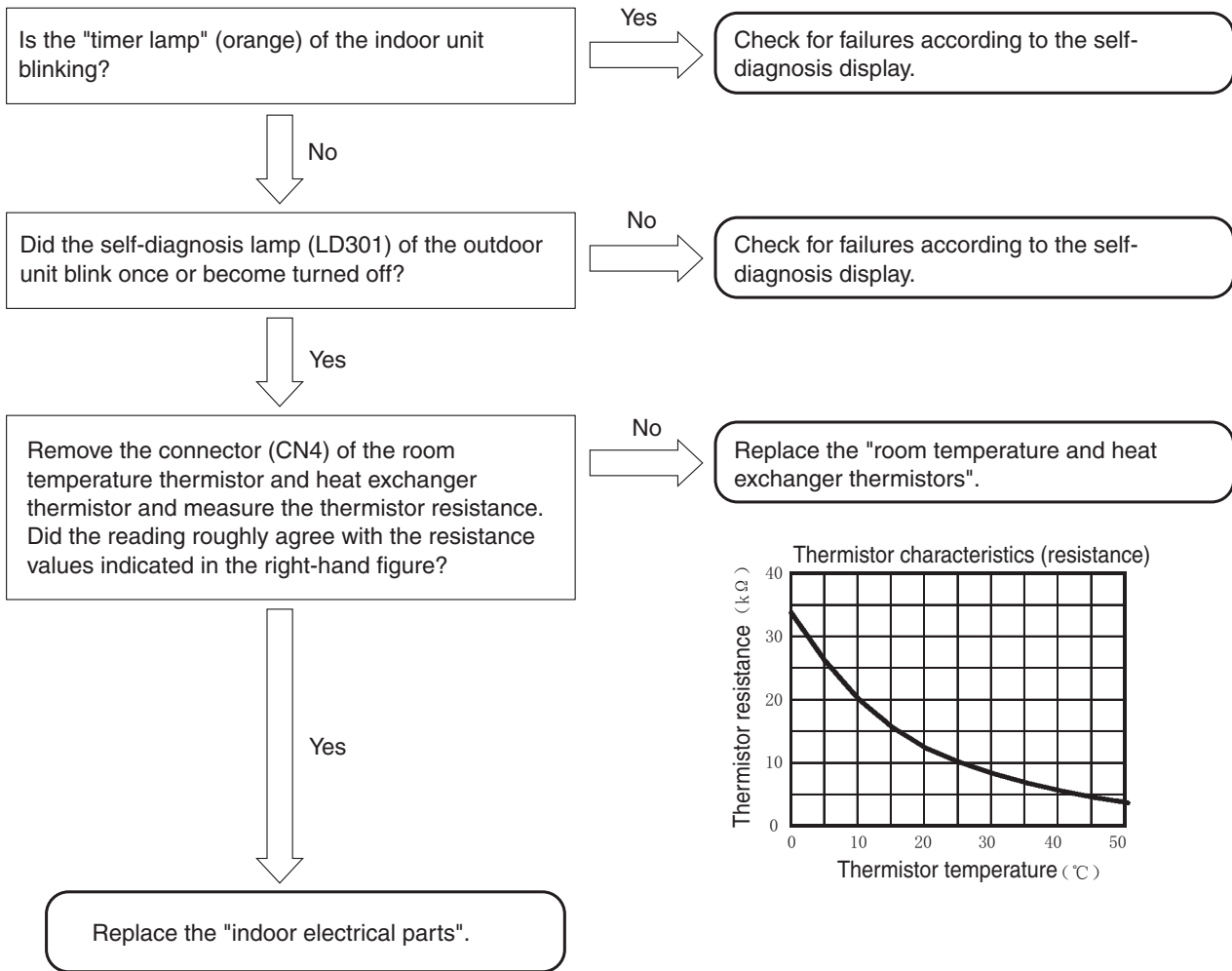

4. Failure phenomenon: The fan motor will not stop.

[Situation] I have conducted the stop operation on the product by remote control, but the indoor fan motor will not stop.
(It stopped about 10 minutes later.)

[Estimated failure locations]

- Indoor fan motor
- Fan motor drive circuit

[Diagnosis flow]

Initiating troubleshooting

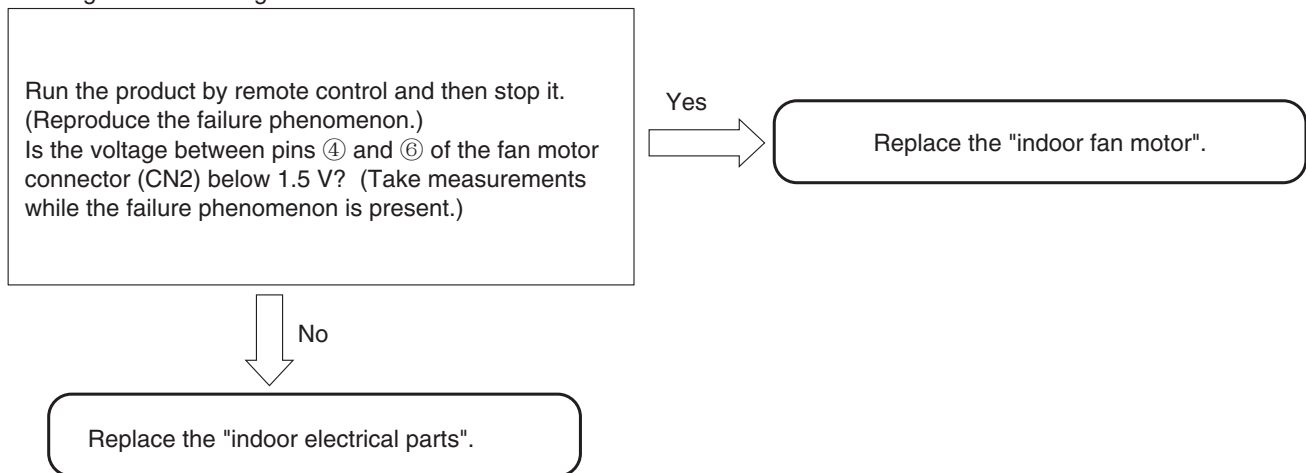

5. Timer lamp blinking: blinking once

[Situation] The timer lamp blinks one time and the product will not operate.
(This is not a sign of a breakdown.)

- [Estimated failure locations]
- Reversing valve defective.
 - The refrigerating cycle block gas leak.

6. Timer lamp blinking: blinking twice

[Situation] The product is giving a display to indicate that it is performing forcible cooling.
(This is not a sign of a breakdown.)

7. Timer lamp blinking: blinking three times

[Situation] The timer lamp blinks three times and the product will not operate.

- [Estimated failure locations]
- Meltdown of the terminal board temperature fuse (the terminal board poorly inserted into the F cable)
 - Outdoor communication circuit out of order

[Cautions]

- If a terminal board is replaced to counter the meltdown of the terminal board temperature fuse, ensure that the F cable to be inserted into the terminal board has the appropriate dimension for peeling the insulation sheathing and that the insertion region is unbent before inserting it into the terminal board securely.

[Diagnosis flow]
Initiating troubleshooting

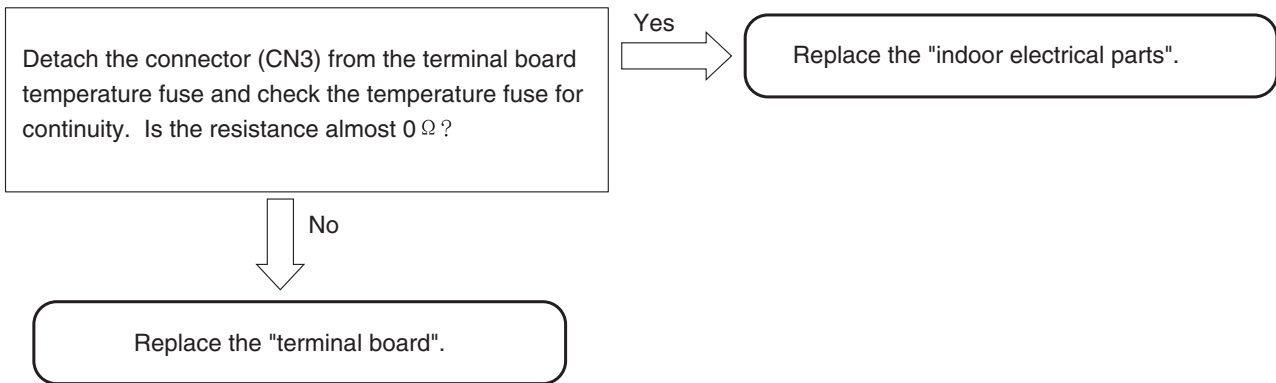

8. Timer lamp blinking: blinking four times

[Situation] The timer lamp blinks four times and the product will not operate.

- [Estimated failure locations]
- Outdoor unit error.
 - Please confirm the times of the LD301 blinking, and then see the outdoor selfcheck table.

9. Timer lamp blinking: blinking 9 times

[Situation] The timer lamp blinks 9 times and the product will not run.

[Estimated failure location] • Loose connector, wire break, or short-circuit in the room temperature thermistor, heat exchanger thermistor.

[Cautions] • Starting the product by remote control will initiate failure detection.
(Merely turning on the power will not activate the failure detection function.)

[Diagnosis flow]

Initiating troubleshooting

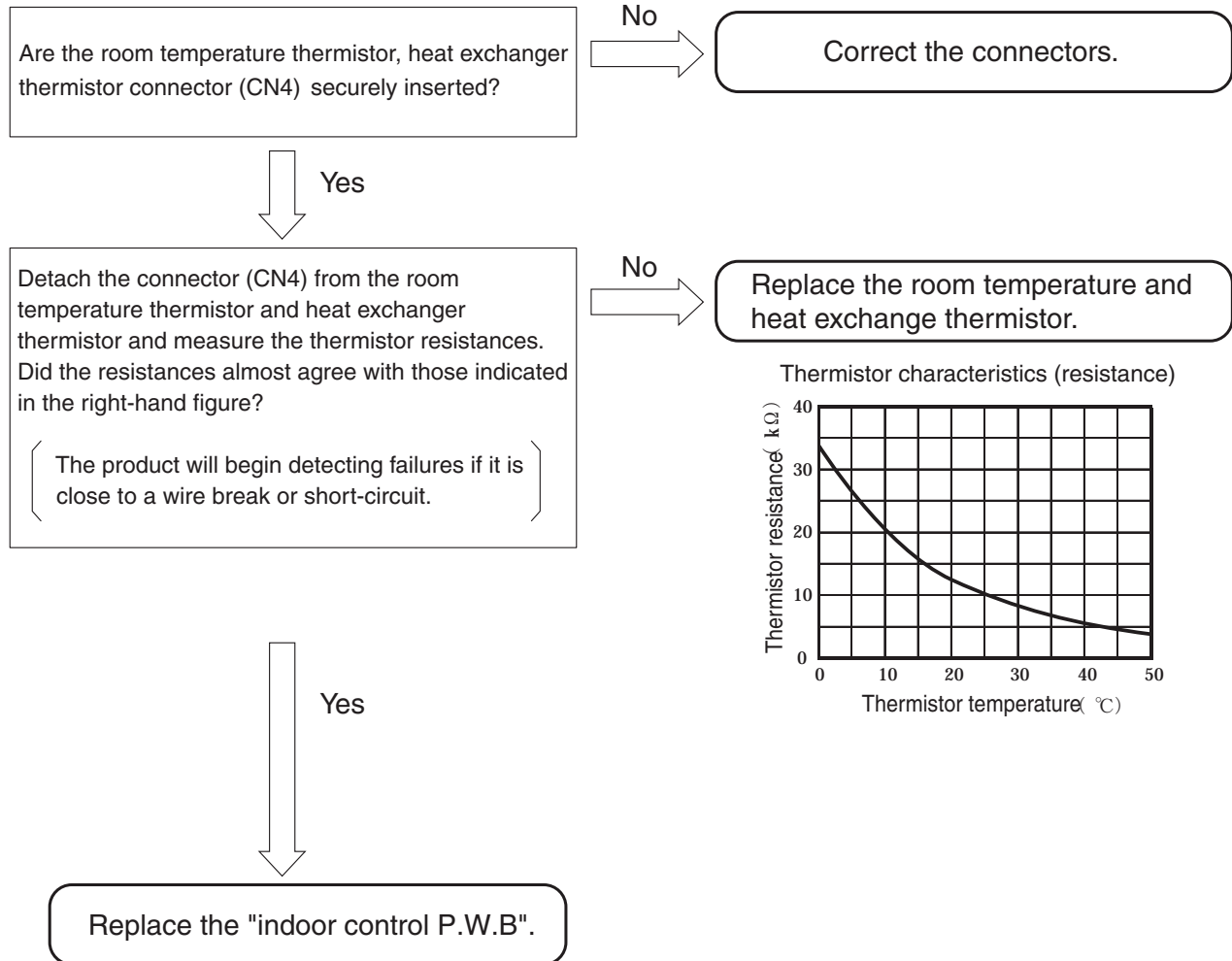

10. Timer lamp blinking: blinking 10 times

[Situation] The timer lamp blinks 10 times and the product will not run.

- [Estimated failure locations]
- Loose connector or wire break in the indoor fan motor
 - Indoor fan motor mechanically locked
 - Indoor fan motor
 - Indoor fan motor drive circuit

[Diagnosis flow]

Initiating troubleshooting

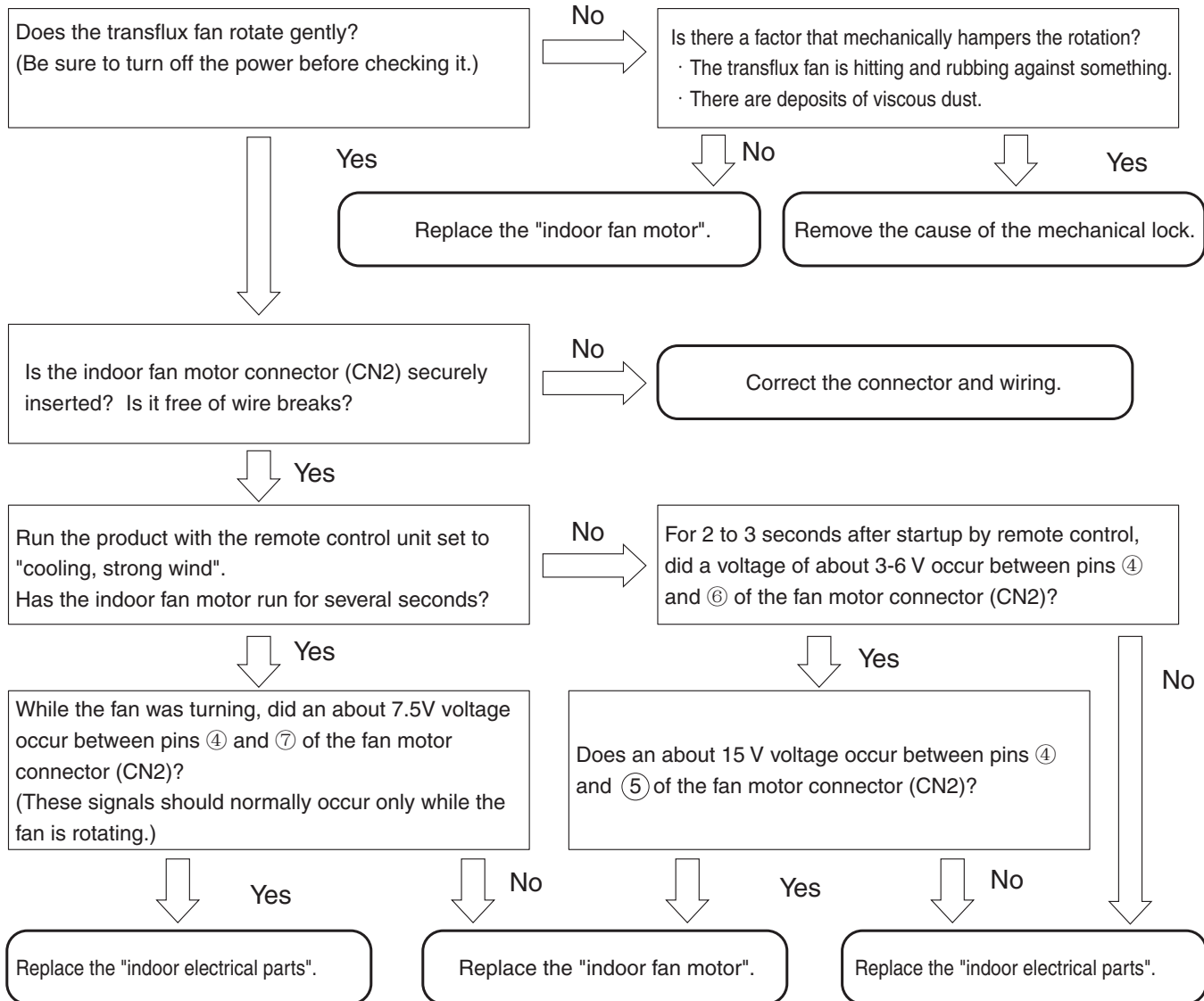

11. Timer lamp blinking: blinking 12 times

[Situation] The timer blinks 12 times and the product will not run.

- [Estimated failure locations]
- Erroneous connection in the indoor-outdoor connection line (F cable)
 - Forget to connect CN27 of outdoor P.W.B
 - Wire break or poor insertion of the indoor-outdoor connection line (F cable)
 - Electrical parts in the outdoor unit (communication circuit, power circuit error)
 - Communication error due to noise in other home electronics
 - ※This does not constitute a failure in the air-conditioner

[Cautions] • When lines 1 and 2 of F cable are erroneously connected (crossed), the product may not enter self-diagnosis display mode. If the self-diagnosis memory stores data about "timer lamp blinked 12 times", then, just in case, check if the F cable is not erroneously connected.

[Diagnosis flow]

Initiating troubleshooting

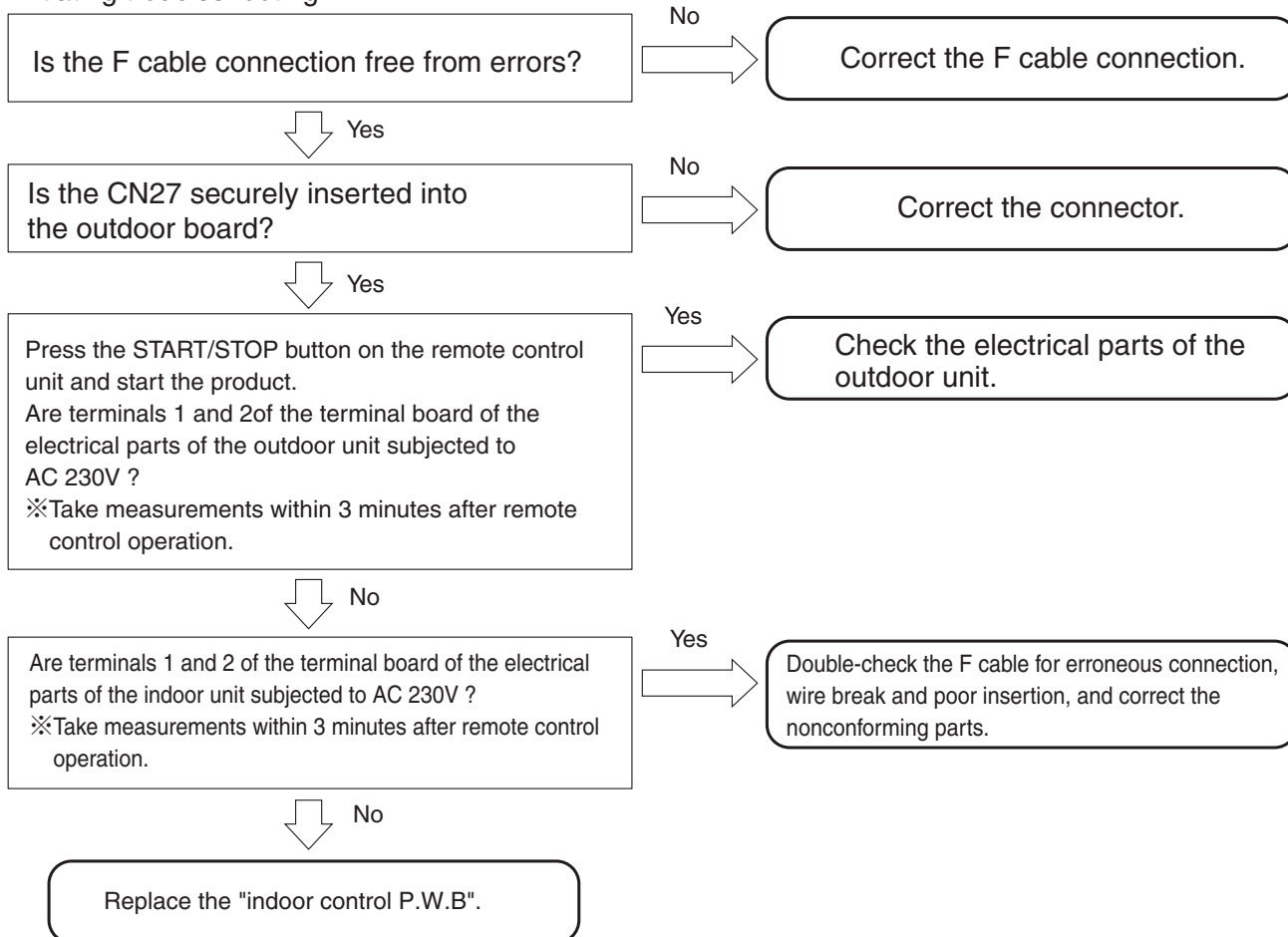

12. Timer lamp blinking: blinking 13 times

[Situation] The timer lamp blinks 13 times and the product will not run.

[Estimated failure location] • EEPROM, microcomputer

[Diagnosis flow]

Replace the "indoor control P.W.B".

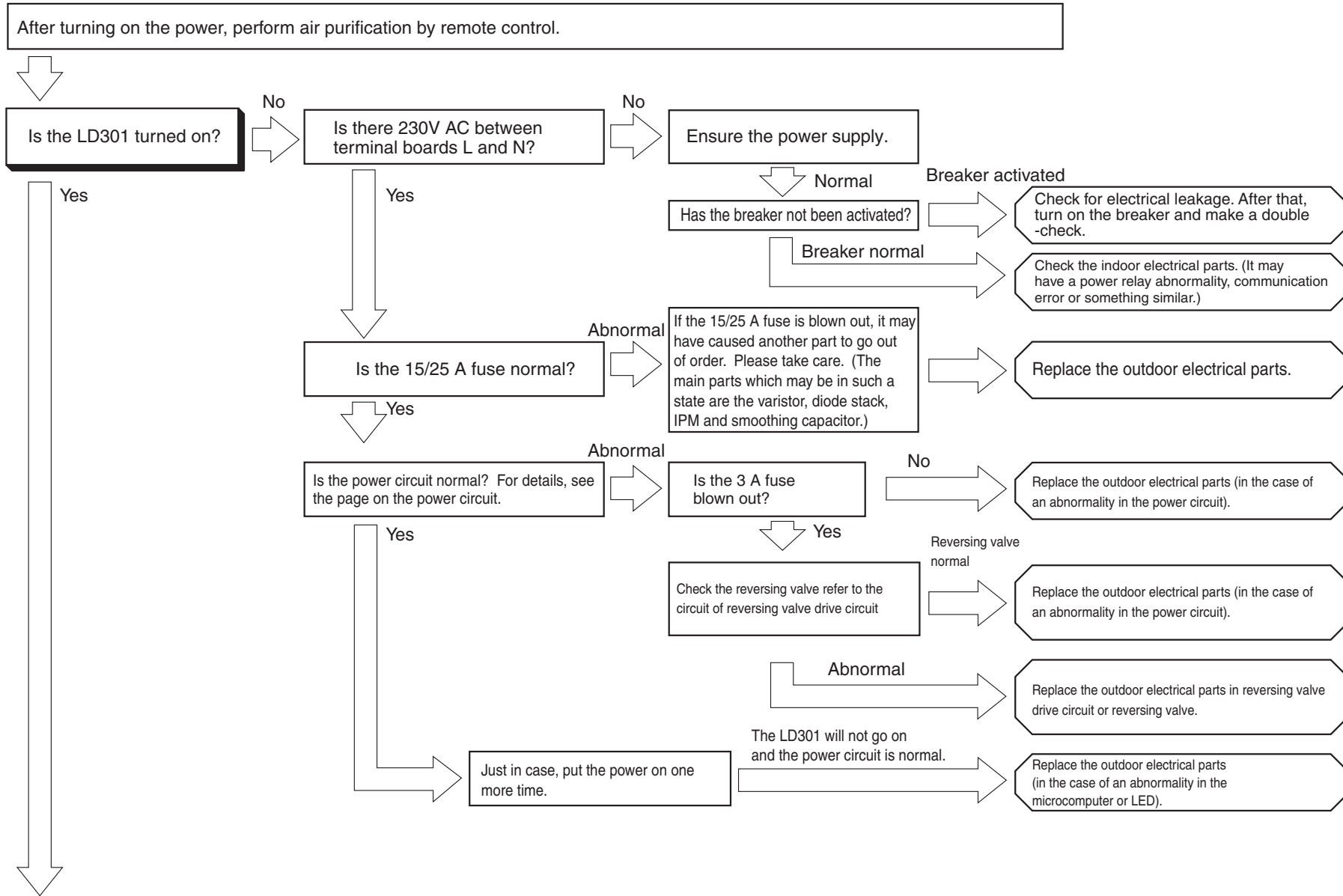

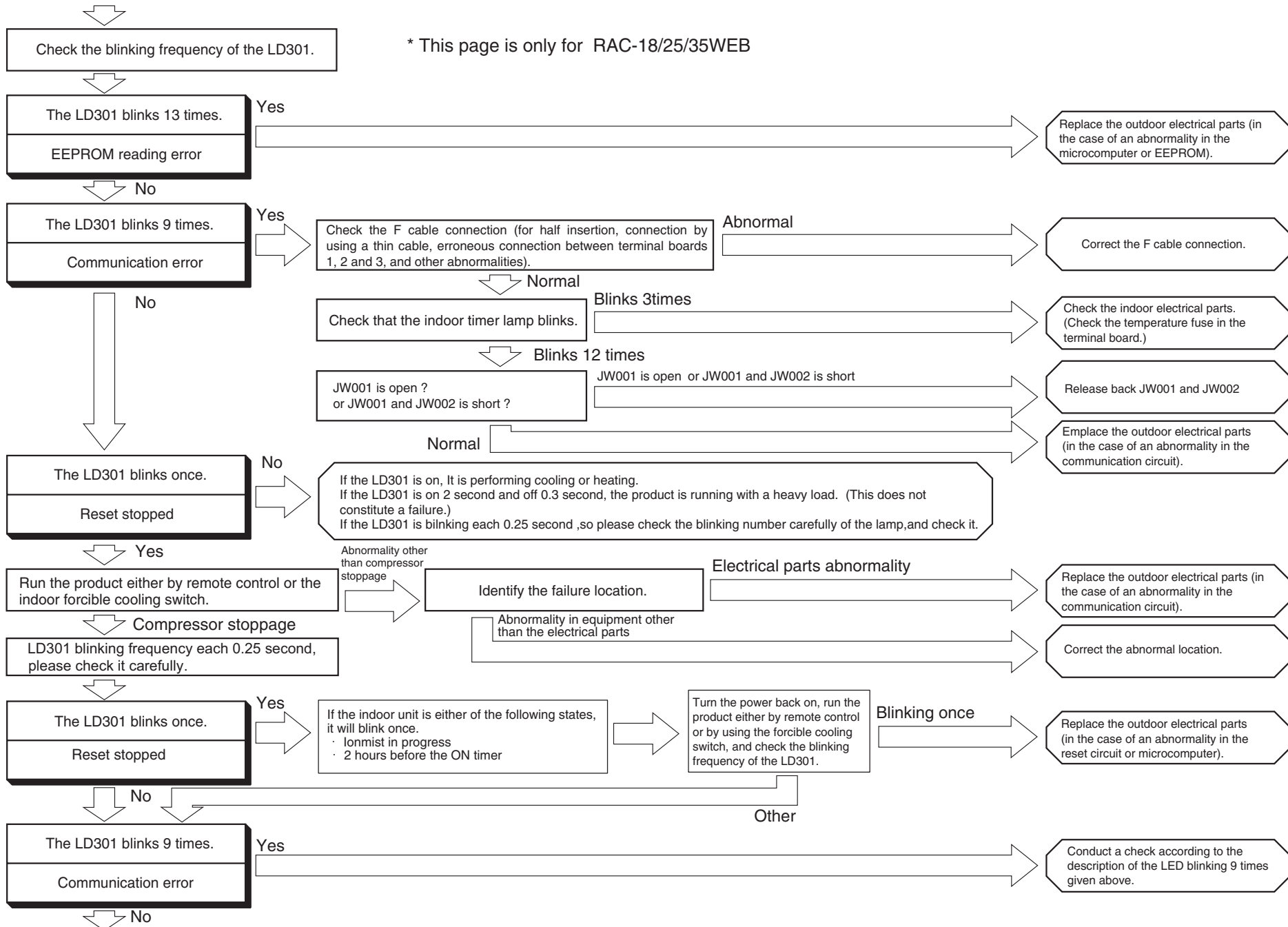

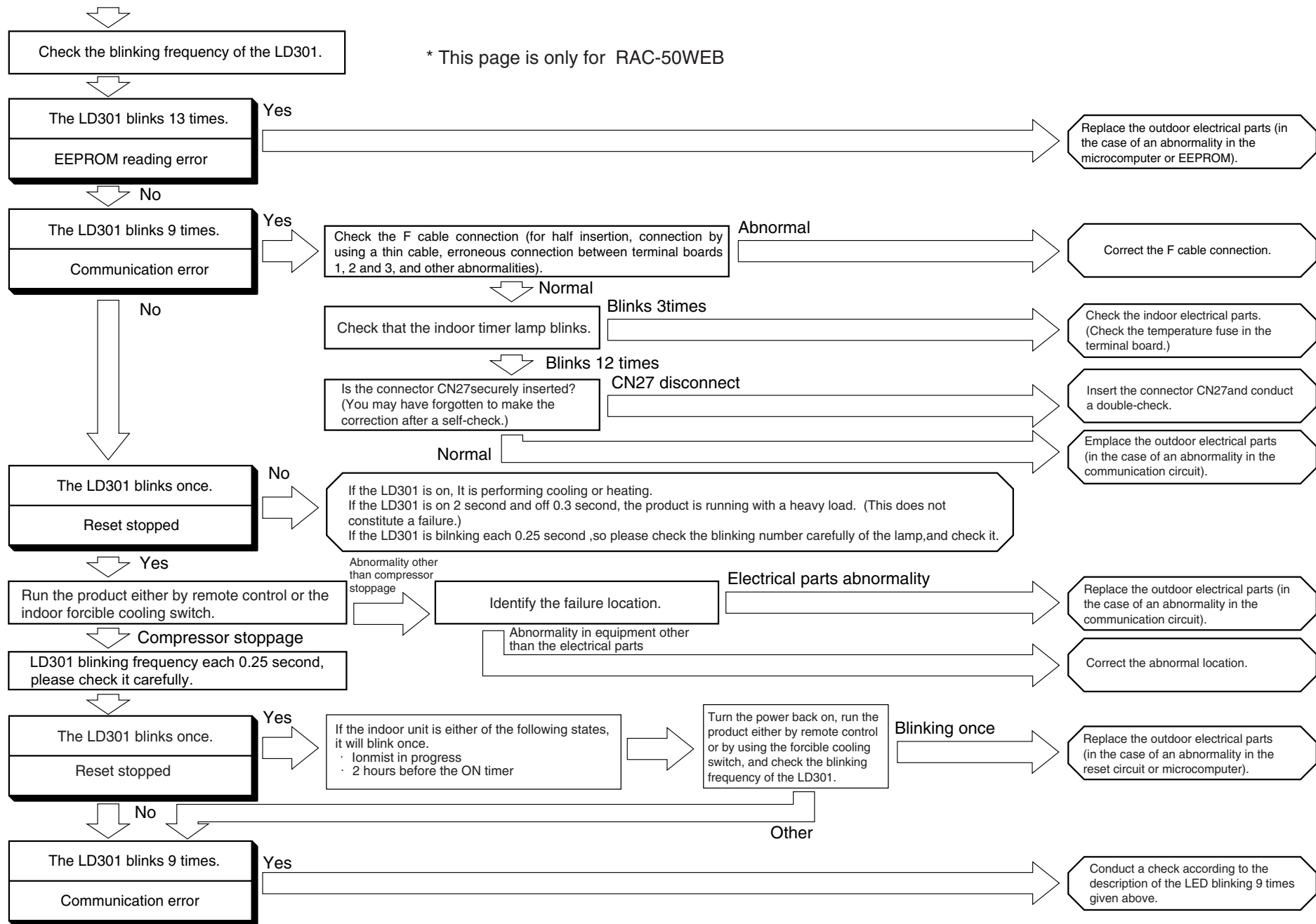

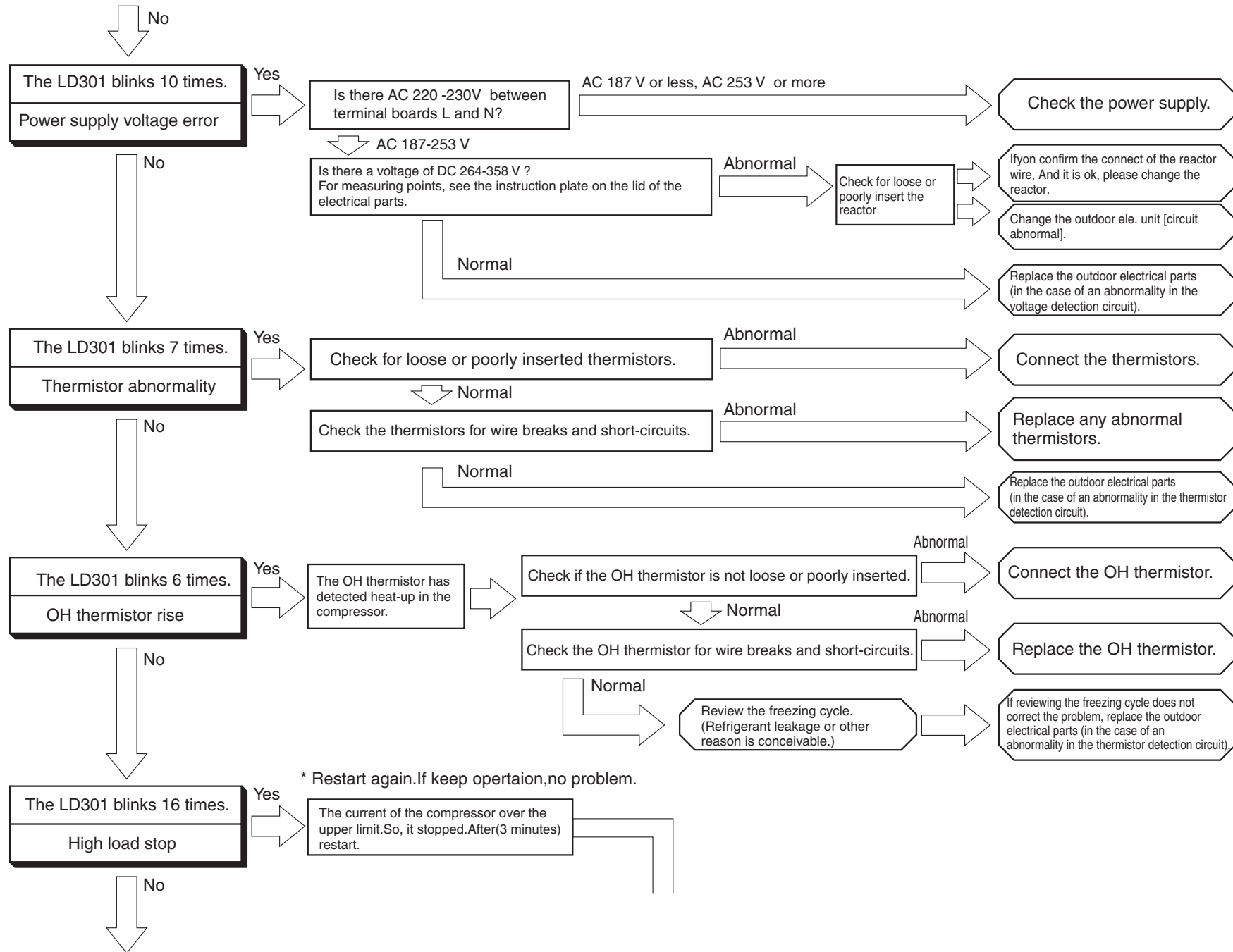

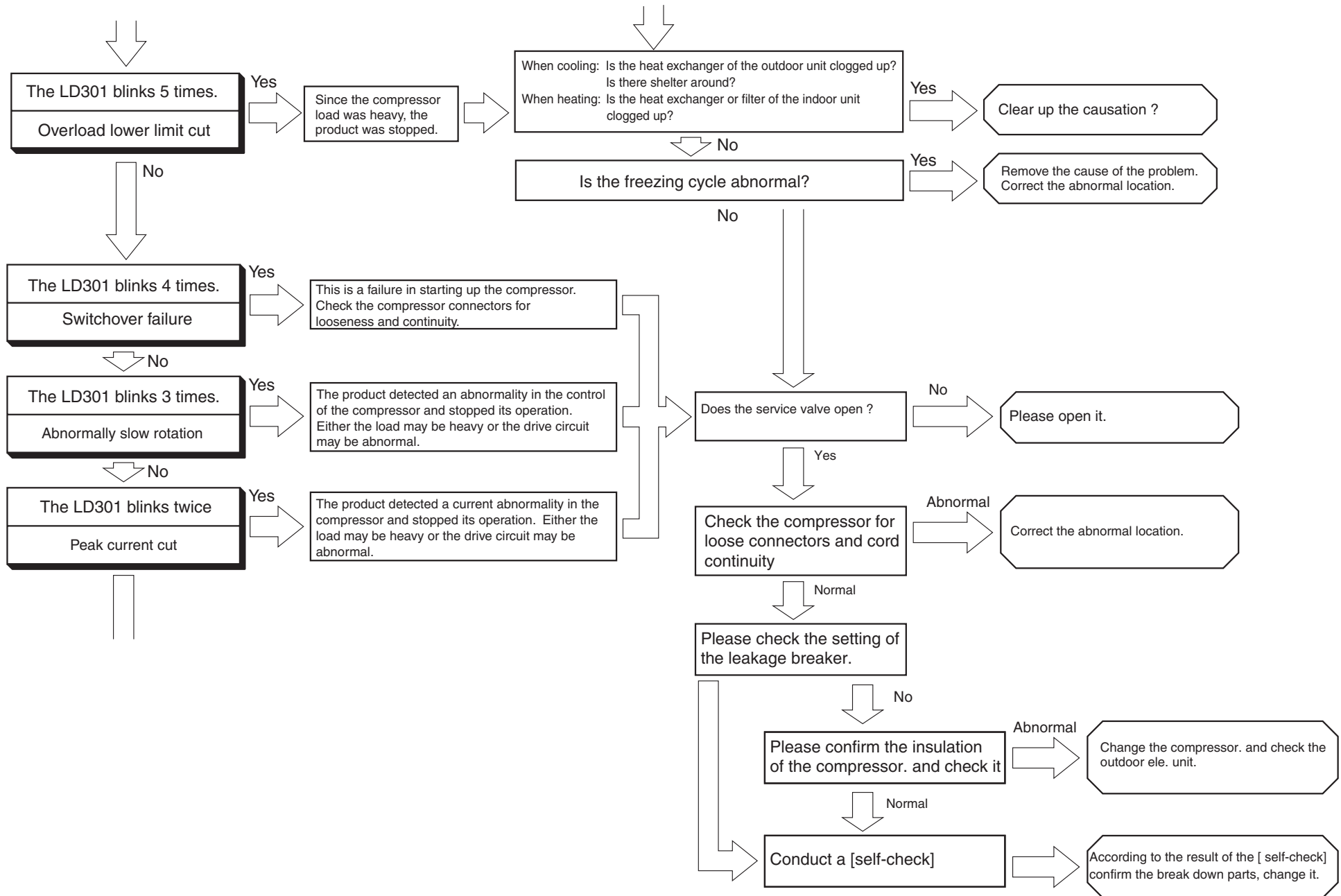

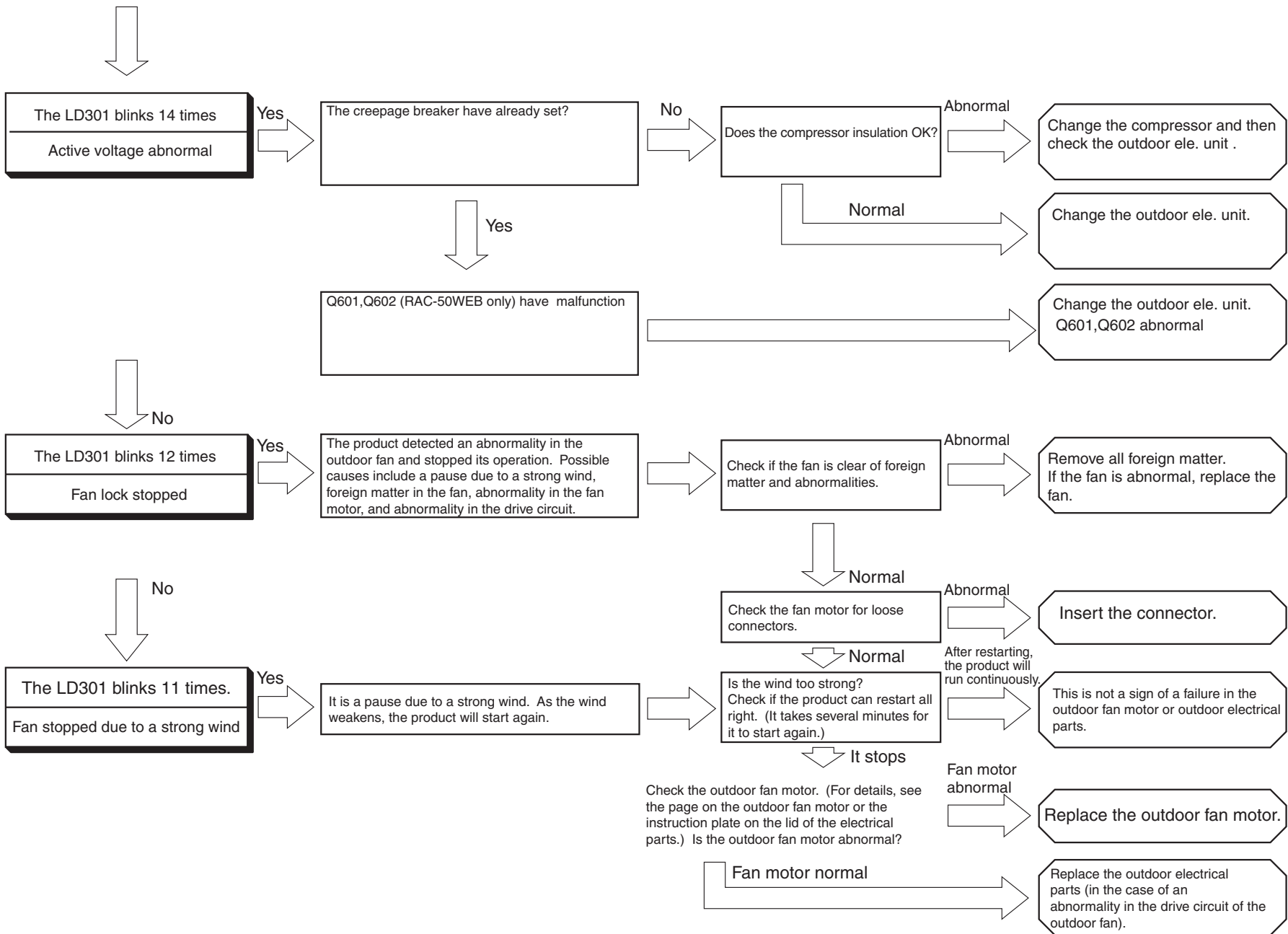

SETTING THE PREVENTION OF MUTUAL INTERFERENCE FOR REMOTE CONTROLLER

Case : 2 sets of indoor units installed near to each other.

If both indoor units can receive the same remote controller signal, please set the remote controller as below. (This setting will change the signal address of each remote controller.)

Initial remote controller signal address setting is A.

This procedure change the remote controller signal address from A to B.

1.Remove rear cover as shown in figure

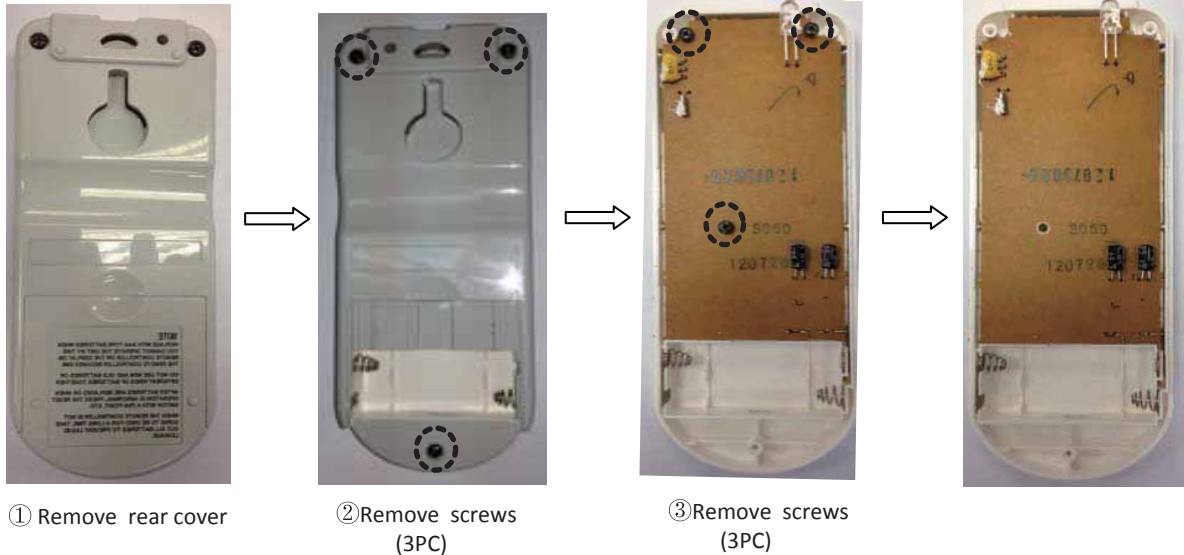

2.Short the JSW1 or J1 ON PCB according to different supplier.

For distinguishing them, we attached different type label in the battery case as below.

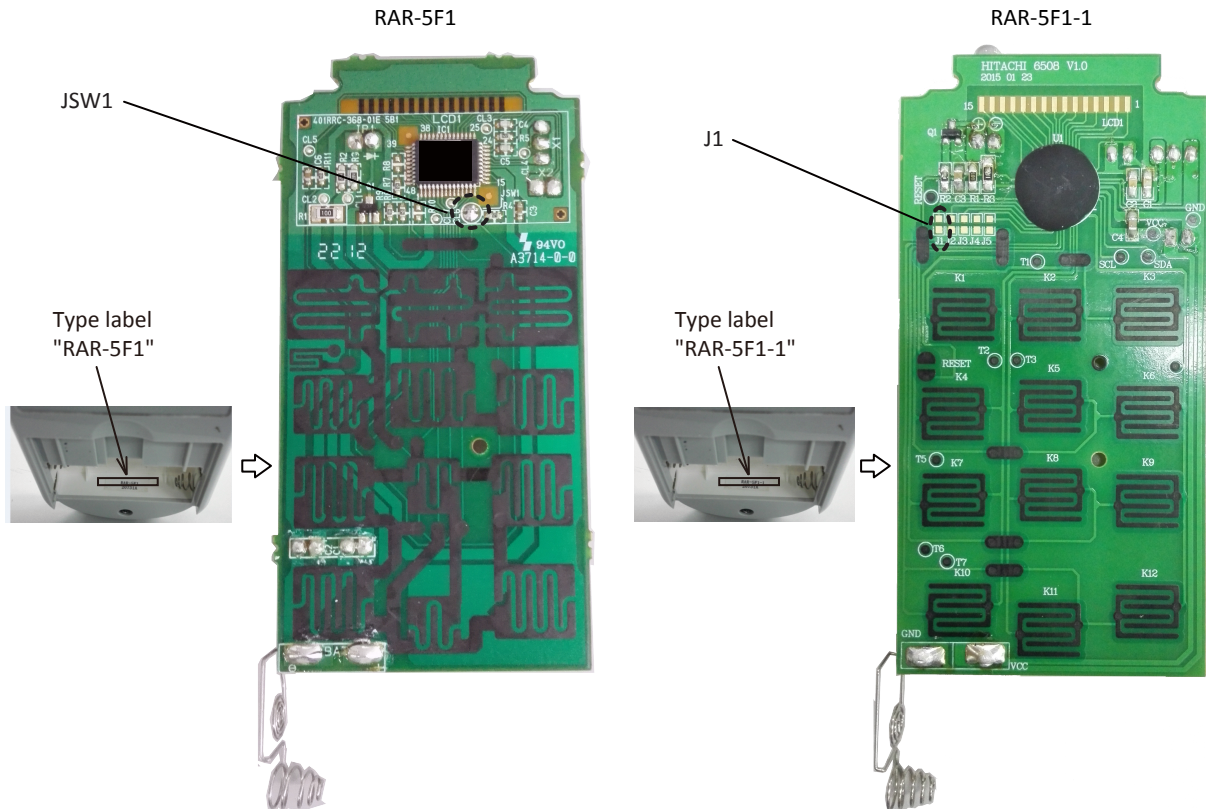







NOTE: Please set the DIP switch No.6 to ON accordingly (Refer to page 48).

HOW TO CHANGE THE SHIFT VALUE SETTING TEMPERATURE

The shift value setting temperature for Cooling and Heating mode operation can be changed using the remote controller. (This procedure shall be implemented strictly by service personnel only.)

PROCEDURES

1. Press and hold  (OFF) button and  (ON) button.
2. Press  [RESET] button at the same time. Release  [RESET] button only, then release  (OFF) and  (ON) button once Screen 1 appears.



3. Press the  button to display  fan mode (Screen 3).

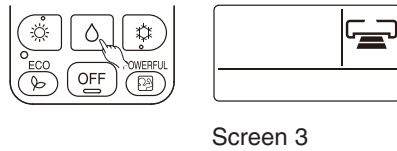

1. Press the Temperature button ( or ) to change the shift value. (The shift value is changed with a beep.)

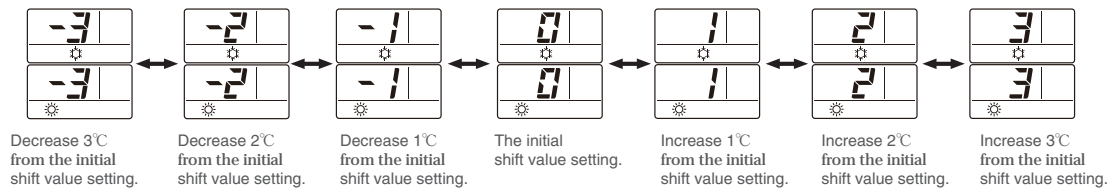

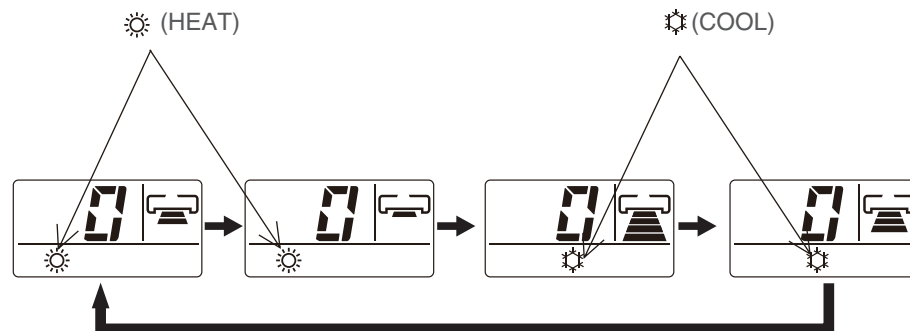

2. Select  (FAN SPEED) button to choose Heating Shift or Cooling Shift Mode (Screen 4).

By setting fan speed to HIGH  or MED , it will go to Cooling Shift mode.
By setting fan speed to LOW  or SILENT , it will go to Heating Shift mode.



Screen 4

NOTE:

1. There are total of 7 shift values ranging from -3 to 3.
2. The displayed shift value,  (HEAT) and  (COOL) symbol on the remote controller display will be disappear after 10 seconds
3. The changed shift value will remain unchanged after turned off the power.
4. If "0" is displayed on the remote controller display, it indicates the shift value is now at the initial setting.

CHECKING THE REFRIGERATING CYCLE

(JUDGING BETWEEN GAS LEAKAGE AND COMPRESSOR DEFECTIVE)

1. Troubleshooting procedure (No operation, No heating, No cooling)

Connect U,V,W phase leads to the power module again and operate the air conditioner.

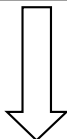

Is the self-diagnosis lamp mode as shown on the right?

Lighting mode Self-diagnosis lamp	Blinks 2 times	Blinks 3 times	Blinks 4 times	Blinks 5 times	Blinks 6 times	Blinks 8 times
LD301						
Time until the lamp lights	Approx. 10 seconds			Approx. 10 seconds	Within Approx. 30 seconds	Approx. 10 seconds
Possible malfunctioning part	Compressor				Gas leakage	Compressor

Blinking off

Outdoor air temperature (°C)	Charge port pressure MPa(G) {kgf/cm ² (G)}
50	2.96 {30.14}
45	2.62 {26.72}
40	2.31 {23.58}
35	2.03 {20.73}
30	1.78 {18.14}
25	1.55 {15.79}
20	1.34 {13.66}
15	1.15 {11.74}
10	0.98 {10.02}
5	0.83 {8.48}
0	0.70 {7.10}
-5	0.58 {5.89}
-10	0.47 {4.81}

(R410 A)
The values above are the theoretical ones.

YES

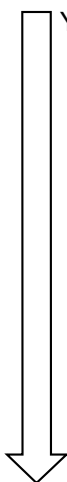

Stop to operate and check the gas pressure in balancing mode.

Normal

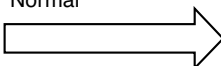

• Checking the IPM (main P.W.B.)

Error (Gas leaking)

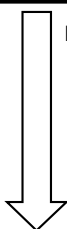

Gas leaks.
Repair and seal refrigerant.

When the self-diagnosis lamp lights in the same condition as above.

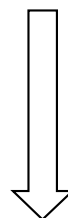

The compressor is defective. Replace it and seal refrigerant.
(If the compressor checker for an inverter type air conditioner is available, re-check using it.)

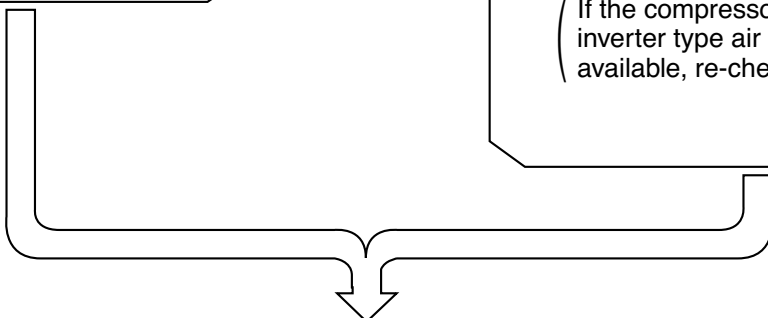

Perform a final check of operation.

How to run the product with the outdoor unit test switch

If the indoor electrical parts is out of order and if you wish to run the outdoor unit

1. Turn on the outdoor terminal boards L and N (220-230 V AC).
2. Confirm that the "LD301" blinks once from the terminal side of the outdoor unit. Afterwards (when about 30 sec elapses after the power turns on), confirm that the "LD301" changes to blinking 9 times (communication error).
3. When the "LD301" is blinks 9 times, if you press the test switch, the "LD301" lights up.

If you release your finger from the test switch within 1 sec to 5 sec after pressing the switch, the forced cooling operation starts.

※(If you press the test switch for 5 sec or longer, the self-check diagnosis starts. In this case, turn the power off and start the procedure from 1 again.)

※(For the initialization of the expansion valve, it may take 1 min until the operation starts.)

4. When you press the test switch again for 1 sec or longer, the unit stops the operation.

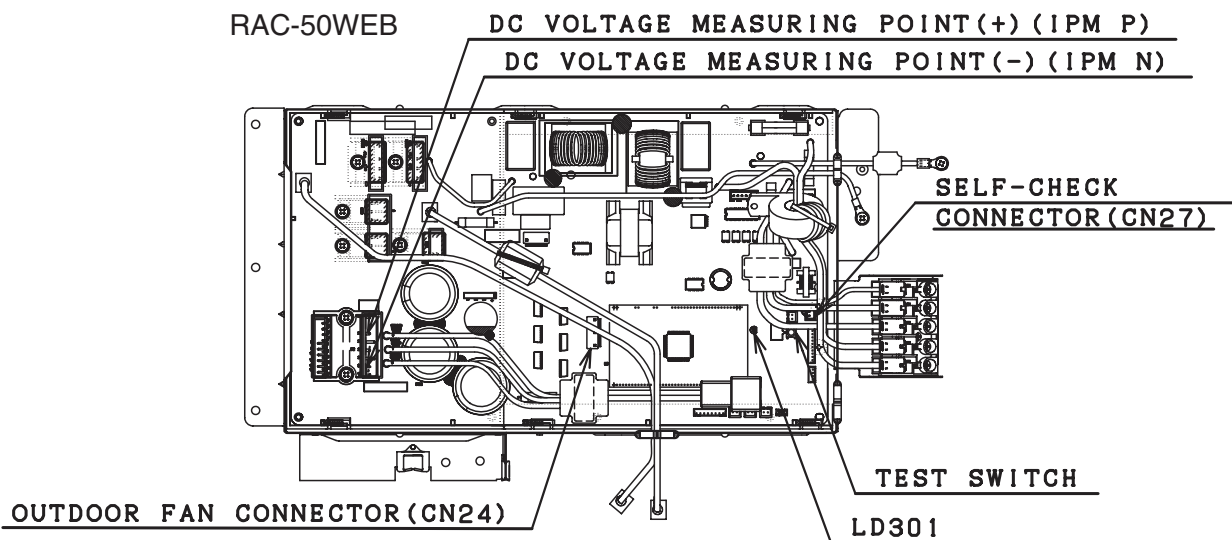
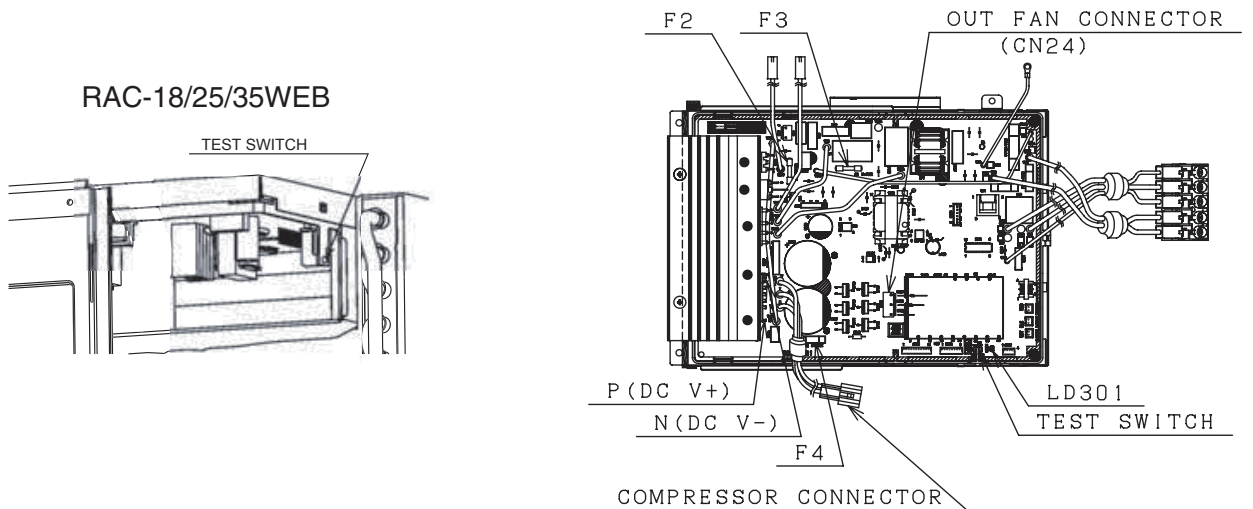

※Cautions

1. Applying power directly to the outdoor unit will cause a rush current to stress the outdoor unit. Therefore, if the indoor unit is not out of order, do not use the method described in 2).
2. Before making the connections, be sure to turn off the breaker.
3. Do not under any circumstances run the product for more than 5 minutes.
4. Doing work with the compressor connector removed will cause the LD301 to blink 4 times. It will not start.
5. For another test run, turn off the breaker and turn it back on. (The test switch is accepted only once after power-on. After operation by remote control, it is not accepted.)
6. When the operation with the test switch is over, turn off the breaker and set the connectors back.

HOW TO OPERATE THE OUTDOOR UNIT INDEPENDENTLY

RAC-18/25/35WEB

1. Connect the large dia. pipe side and small dia. pipe side service valve using a pipe.

Connect the small diameter service valve and the large diameter service valve using the reducing union and copper pipe as shown on the right.

Charge refrigerant of 300g after vacuuming (※1)

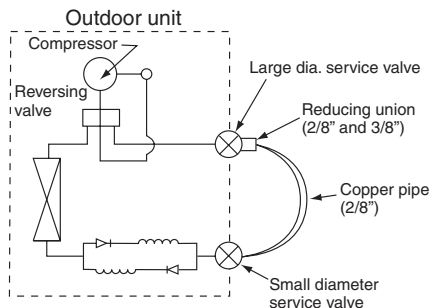

Parts to be prepared

- (1) Reducing union
2/8" (6.35 mm)
3/8" (9.52 mm)
- (2) Copper pipe (2/8" and 3/8")

Do not operate for more than 5 minutes

The operation method is the same as "How to operate using the connector to servicing the outdoor unit".

※1 The charging amount of 300g is equivalent to the load in normal operation.

RAC-50WEB

1. Connect the large dia. pipe side and small dia. pipe side service valves using a pipe.

Connect the small diameter service valve and the large diameter service valve using the reducing union and copper pipe as shown on the right.

Charge refrigerant of 300g after vacuuming (※1)

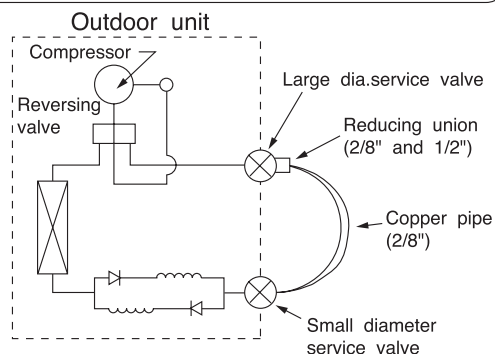

Parts to be prepared

- (1) Reducing union
2/8" (6.35mm)
1/2" (12.7mm)
- (2) Copper pipe (2/8" and 1/2")
- (3) Shorting leads
2 leads approx. 10 cm long
with alligator clip or IC clip

Do not operate for 5 minutes or more.

The operation method is the same as "How to operate using the connector to servicing the outdoor unit".

※1 The charging amount of 300g is equivalent to the load in normal operation.

PARTS LIST AND DIAGRAM

INDOOR UNIT

MODEL: RAK-18PEB,RAK-25PEB,RAK-35PEB,RAK-50PEB
RAK-25PEBC,RAK-35PEBC,RAK-50PEBC

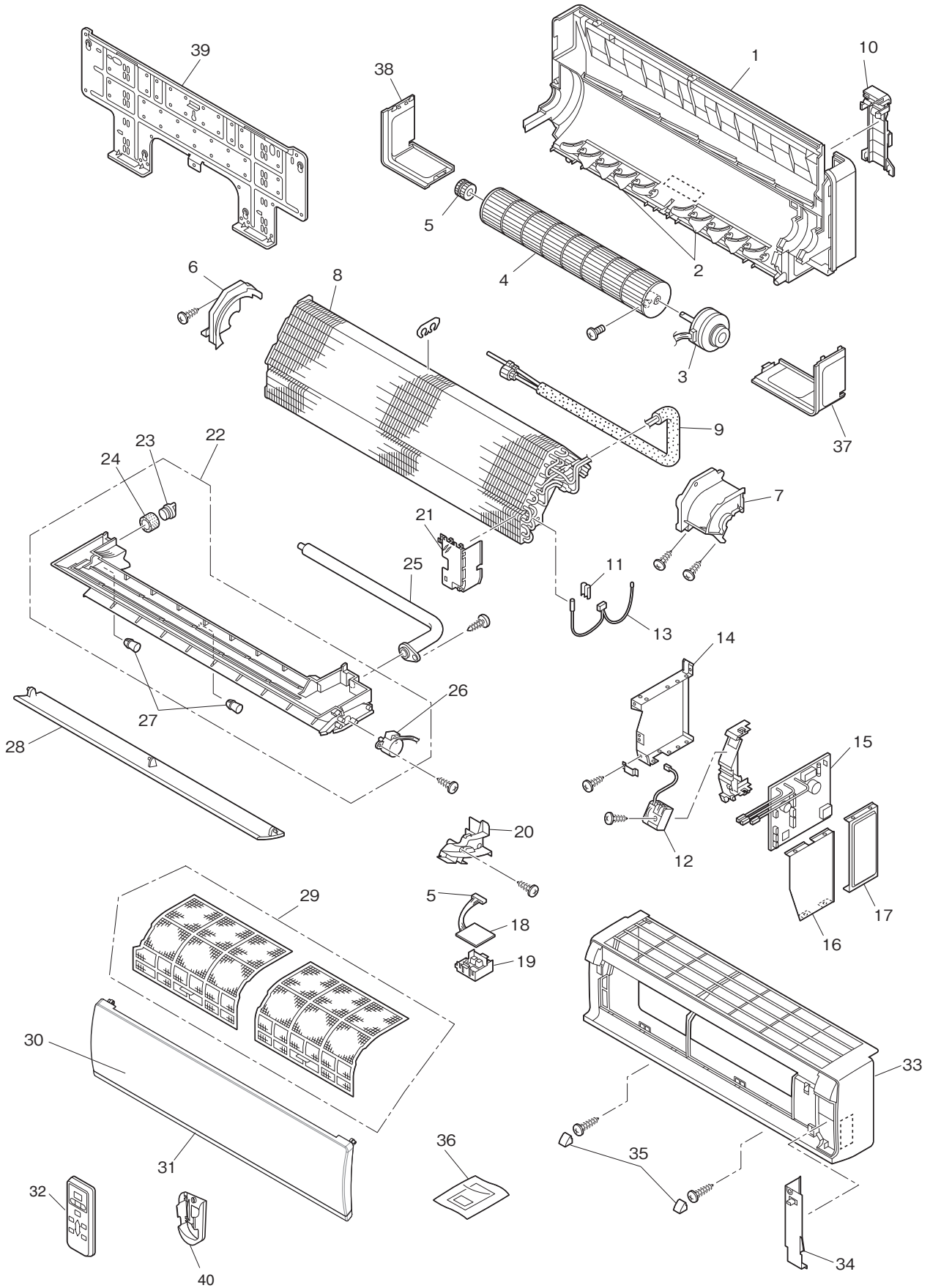

NO	HHAW PARTS NO				Q' TY/ UNIT	PARTS NAME
	RAK-18PEB	RAK-25PEB	RAK-35PEB	RAK-50PEB		
1	HWRAK-18PSPA 901				1	CABINET ASS'Y
2	HWRAK-25PEA 902				2	VERTICAL AIR DEFLECTOR
3	HWRAK-18PEB 901				1	FAN MOTOR
4	HWRAK-18PSPA 902				1	TANGENTIAL AIR FLOW FAN
5	HWRAS-25YH4 908				1	FAN SUPPORT ASS'Y
6	HWRAS-E10H3 905				1	FAN COVER
7	HWRAS-10EH4 901				1	FAN MOTOR SUPPORT
8	HWRAK-18PEB 902			HWRAK-50PEB 902	1	EVAPORATOR ASS'Y
9	HWRAS-E10H3 908			HWRAS-X18CBK A02	1	PIPING ASS'Y
10	HWRAS-E10H3 909				1	UPPER COVER
11	HWRAS-25YH4 A15				1	SPRING
12	HWRAK-18PEB 904				1	TERMINAL BOARD (3P)
13	HWRAS-E10H3 911				1	THERMISTOR ASS'Y
14	HWRAK-18PEB 905				1	COVER (ELECTRIC)
15	HWRAK-18PEB 906	HWRAK-25PEB 901	HWRAK-35PEB 901	HWRAK-50PEB 901	1	P. W. B. (MAIN)
16	HWRAK-18PEB 907				1	ELEC-COVER-L
17	HWRAK-18PEB 908				1	ELEC-COVER-R
18	HWRAK-18PEB 909				1	P. W. B. (INDICATION)
19	HWRAS-E10H3 917				1	LED-COVER
20	HWRAS-E10H3 918				1	FC-GUIDE
21	HWRAS-E10H3 919				1	PIPE COVER
22	HWRAK-18PEB 910				1	DRAIN PAN ASS'Y
23	HWRAS-25YH4 A30				1	DRAIN CAP
24	HWRAS-25YH4 A31				1	FO-PIPE
25	HWRAS-E10H3 921				1	DRAINAGE PIPE
26	HWRAK-18PSPA 910				1	STEPPING MOTOR
27	HWRAS-25YH4 A28				2	DEFLECTOR SUPPORT
28	HWRAS-E10HA 901				1	HORIZONTAL AIR DEFLECTOR
29	HWRAS-E10H3 924				1	AIR FILTER
30	HWRAK-25PEA 906				1	FRONT PANEL AS
31	HWRAK-25PEA 907				1	K-PANLE
32	HWRAS-K10HCG 919				1	REMOTE CONTROL ASS'Y
33	HWRAK-18PPB 903				1	FRONT COVER
34	HWRAS-E10H3 927				1	T-COVER ASS'Y
35	HWRAS-E10H3 928				2	CAP
36	HWRAK-18PEB 911				1	H-LABEL
37	HWRAS-E10H3 930				1	S-COVER-R
38	HWRAS-E10H3 931				1	S-COVER-L
39	HWRAS-E10H3 932				1	MOUNTING PLATE
40	HWRAS-E10CXK 014				1	RE-HOLDER

NO	HHAW PARTS NO			Q' TY/ UNIT	PARTS NAME
	RAK-25PEBC	RAK-35PEBC	RAK-50PEBC		
1	HWRAK-18PSPA 901			1	CABINET ASS'Y
2	HWRAK-25PEA 902			2	VERTICAL AIR DEFLECTOR
3	HWRAK-18PEB 901			1	FAN MOTOR
4	HWRAK-18PSPA 902			1	TANGENTIAL AIR FLOW FAN
5	HWRAS-25YH4 908			1	FAN SUPPORT ASS'Y
6	HWRAS-E10H3 905			1	FAN COVER
7	HWRAS-10EH4 901			1	FAN MOTOR SUPPORT
8	HWRAK-18PEB 902		HWRAK-50PEB 902	1	EVAPORATOR ASS'Y
9	HWRAS-E10H3 908		HWRAS-X18CBK A02	1	PIPING ASS'Y
10	HWRAS-E10H3 909			1	UPPER COVER
11	HWRAS-25YH4 A15			1	SPRING
12	HWRAK-18PEB 904			1	TERMINAL BOARD (3P)
13	HWRAS-E10H3 911			1	THERMISTOR ASS'Y
14	HWRAK-18PEB 905			1	COVER (ELECTRIC)
15	HWRAK-25PEB 902	HWRAK-35PEB 902	HWRAK-50PEB 903	1	P. W. B. (MAIN)
16	HWRAK-18PEB 907			1	ELEC-COVER-L
17	HWRAK-18PEB 908			1	ELEC-COVER-R
18	HWRAK-18PEB 909			1	P. W. B. (INDICATION)
19	HWRAS-E10H3 917			1	LED-COVER
20	HWRAS-E10H3 918			1	FC-GUIDE
21	HWRAS-E10H3 919			1	PIPE COVER
22	HWRAK-18PEB 910			1	DRAIN PAN ASS'Y
23	HWRAS-25YH4 A30			1	DRAIN CAP
24	HWRAS-25YH4 A31			1	FO-PIPE
25	HWRAS-E10H3 921			1	DRAINAGE PIPE
26	HWRAK-18PSPA 910			1	STEPPING MOTOR
27	HWRAS-25YH4 A28			2	DEFLECTOR SUPPORT
28	HWRAS-E10HA 901			1	HORIZONTAL AIR DEFLECTOR
29	HWRAS-E10H3 924			1	AIR FILTER
30	HWRAK-25PEA 906			1	FRONT PANEL AS
31	HWRAK-25PEA 907			1	K-PANLE
32	HWRAS-K10HCG 919			1	REMOTE CONTROL ASS'Y
33	HWRAK-18PPB 903			1	FRONT COVER
34	HWRAS-E10H3 927			1	T-COVER ASS'Y
35	HWRAS-E10H3 928			2	CAP
36	HWRAK-18PEB 911			1	H-LABEL
37	HWRAS-E10H3 930			1	S-COVER-R
38	HWRAS-E10H3 931			1	S-COVER-L
39	HWRAS-E10H3 932			1	MOUNTING PLATE
40	HWRAS-E10CXK 014			1	RE-HOLDER

MODEL RAC-18/25/35WEB

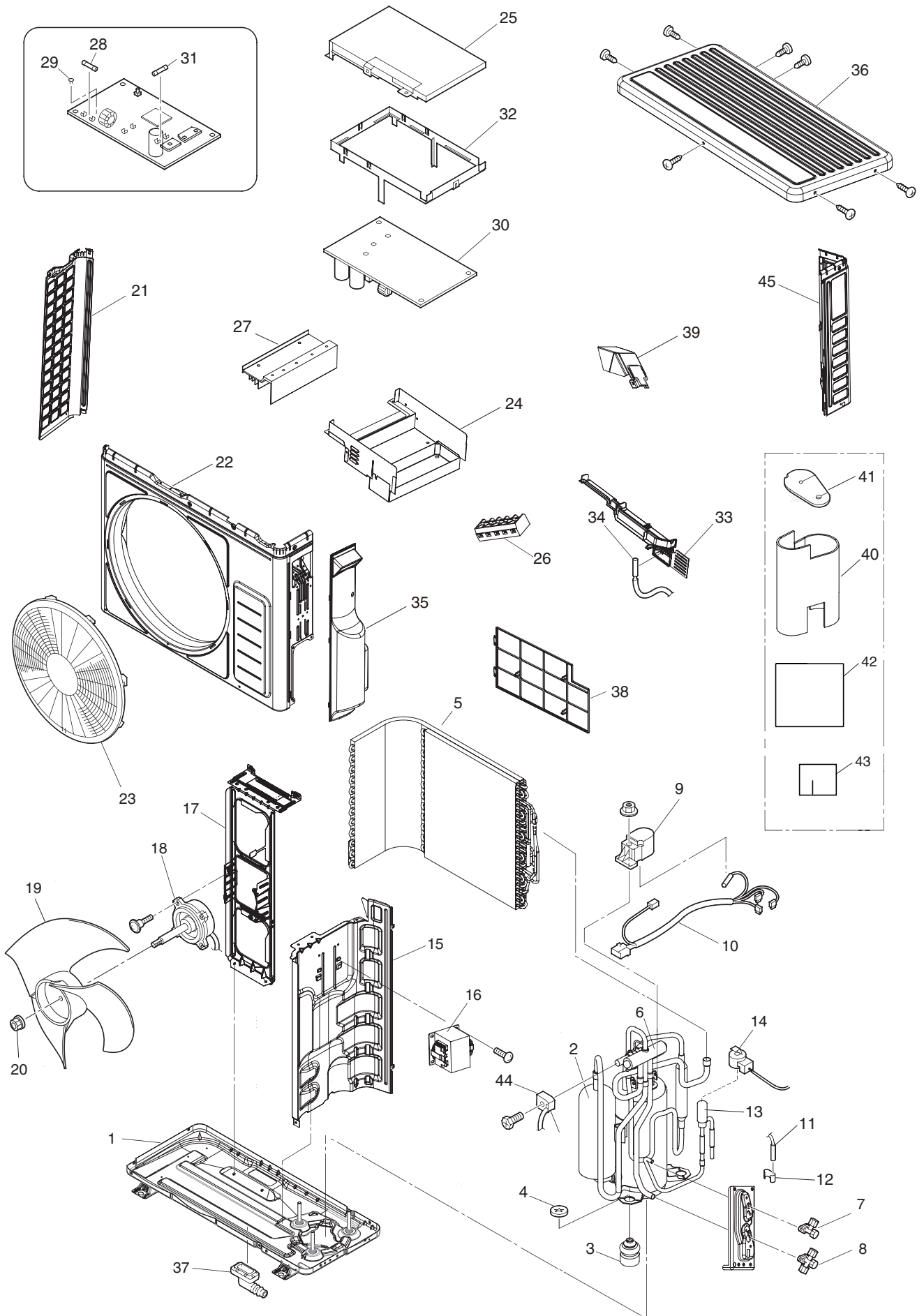

NO	HHAW PARTS NO			Q' TY/ UNIT	PARTS NAME
	RAC-18WEB	RAC-25WEB	RAC-35WEB		
1	HWRAC-18WEB	A01		1	BASE
2	HWRAC-18WEB	A02		1	COMPRESSOR
3	HWRAC-18WEB	A03		3	COMPRESSOR RUBBER
4	HWRAC-18WEB	A04		3	PUSH NUT
5	HWRAC-18WEB	A05		1	CONDENSER
6	HWRAC-18WEB	A06		1	REVERSING VALVE
7	HWRAC-50WEA	A06		1	2S-VALVE
8	HWRAC-10GH5	A03		1	3S-VALVE
9	HWRAC-18WEB	A07		1	O. L. R COVER
10	HWRAC-18WSA	A11		1	CONNECTING CORD (COMP)
11	HWRAC-E10H2	A09		1	THERMISTOR (DEFROST)
12	HWRAC-D10EX	A08		1	THERMISTOR SUPPORT
13	HWRAC-18WEB	A08		1	ELECTRIC EXPAN. VALVE
14	HWRAC-E08H	A09		1	COIL (EXPAN. VALVE)
15	HWRAC-18WEB	A09		1	PARTITION
16	HWRAC-18WEB	A10		1	REACTOR 1
17	HWRAC-18WEB	A11		1	FAN MOTOR SUPPORT
18	HWRAC-18WEB	A12		1	FAN MOTOR
19	HWRAC-18WEB	A13		1	PROPELLER FAN
20	HWRAC-25YH4	A24		1	NUT (PROPELLER. FAN)
21	HWRAC-18WEB	A14		1	SIDE COVER (L)
22	HWRAC-18WEB	A15		1	FRONT COVER
23	HWRAC-18WEB	A16		1	DISCHARGE GRILL
24	HWRAC-18WEB	A17		1	ELECTRIC PARTS PLATE
25	HWRAC-18WEB	A18		1	ELECTRIC PARTS COVER
26	HWRAC-18WEB	A19		2	TERMINAL BOARD (5P)
27	HWRAC-18WEB	A20	HWRAC-35WEB A01	1	HEAT SINK (REGURATOR 1)
28	HWRAC-E08H	A11		1	FUSE (15A)
29	HWRAC-50NX2	A52		2	FUSE (3. 15A)
30	HWRAC-18WEB A21	HWRAC-25WEB A01	HWRAC-35WEB A02	1	P. W. B. (MAIN)
31	HWRAC-18WEB	A22		1	FUSE (15A)
32	HWRAC-18WEB	A23		1	SUPPORT (P. W. B.)
33	HWRAC-18WEB	A24		1	COVER (OUT DOOR THERMISTOR)
34	HWRAC-D10EX	A17		1	THERMISTOR (OUT DOOR TEMP.)
35	HWRAC-18WEB	A25		1	EV-COV-ZU
36	HWRAC-18WEB	A26		1	T-COVERZU
37	HWRAC-25YHA4	A50		1	DRAIN PIPE
38	HWRAC-18WEB	A27		1	PROTECTIVE NET
39	HWRAC-18WEB	A28		1	TERMINAL COVER
40	HWRAC-18WEB	A29		1	SOUND PROOF COVER ASS' Y
41	HWRAC-10EH4	A05		1	SOUND PROOF COVER ASS' Y
42	HWRAC-18WEB	A30		1	SOUND PROOF COVER ASS' Y
43	HWRAC-18WEB	A31		1	SOUND PROOF COVER ASS' Y
44	HWRAC-SX10HAK	A20		1	COIL (REVERSING VALVE)
45	HWRAC-18WEB	A32		1	SIDE COVER (R)

MODEL RAC-50WEB

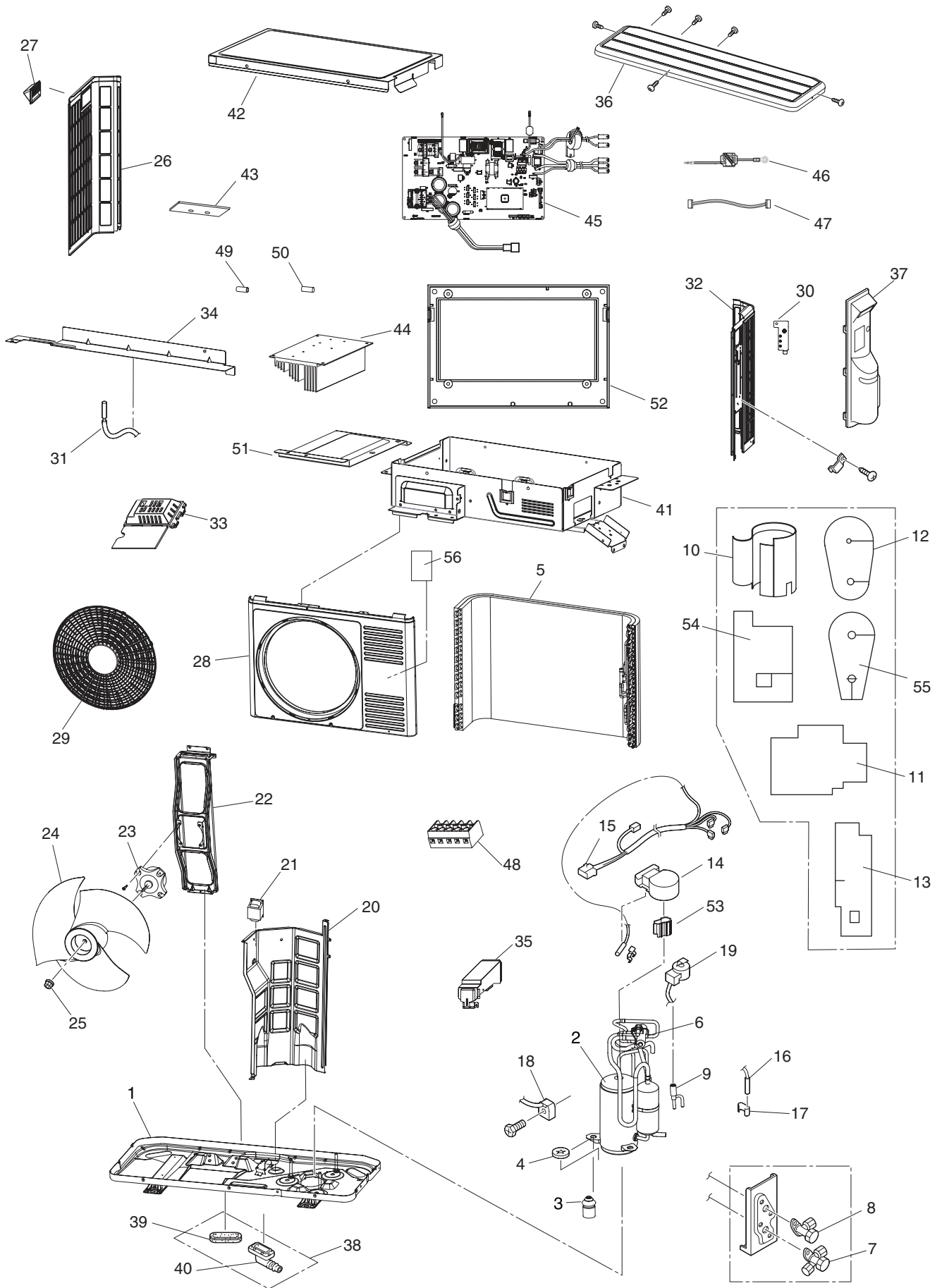

NO	HHAW PARTS NO	Q' TY/UNIT	PARTS NAME
	RAC-50WEB		
1	HWRAC-50WEA A01	1	BASE
2	HWRAC-50WEA A02	1	COMPRESSOR
3	HWRAC-50WEA A03	3	COMPRESSOR RUBBER
4	HWRAC-50NX2 A04	3	PUSH NUT
5	HWRAC-50NX2 A05	1	CONDENSER
6	HWRAC-50WEA A04	1	REVERSING VALVE
7	HWRAC-50WEA A05	1	SERVICE VALVE
8	HWRAC-50WEA A06	1	SERVICE VALVE
9	HWRAC-50NX2 A09	1	ELECTRIC EXPANSTION VALVE
10	HWRAC-50WEA A07	1	SOUND PROOF
11	HWRAC-50WEB A15	1	SOUND PROOF
12	HWRAC-50WEA A09	1	SOUND PROOF
13	HWRAC-50WEB A16	1	SOUND PROOF
14	HWRAC-50WEA A11	1	O. L. R COVER
15	HWRAC-50WEA A12	1	CONNECTING CORD (COMP)
16	HWRAC-50NX2 A16	1	THERMISTOR (DEFROST)
17	HWRAC-50NX2 A17	1	THERMISTOR SUPPORT
18	HWRAC-SX10HAK A20	1	COIL (REVERSING VALVE)
19	HWRAC-50NX2 A19	1	COIL (EXPANSTON VALVE)
20	HWRAC-50WEB A01	1	PARTITION
21	HWRAC-18WSPA A06	1	REACTOR
22	HWRAC-50WEB A02	1	FAN MOTOR SUPPORT
23	HWRAC-50NX2 A23	1	FAN MOTOR
24	HWRAC-50NX2 A24	1	PROPELLER FAN
25	HWRAC-50NX2 A25	1	NUT (PROPELLER FAN)
26	HWRAC-50NX2 A26	1	SIDE COVER (L)
27	HWRAC-50NX2 A27	1	HANDLE
28	HWRAC-50WEB A17	1	FRONT COVER
29	HWRAC-50NX2 A29	1	DISCHARGE GRILL
30	HWRAC-50WEB A03	1	EARTH-PLATE
31	HWRAC-E14H3 914	1	THERMISTOR (OUTDOOR TEMPERATURE)
32	HWRAC-50NX2 A31	1	SIDE COVER (R)
33	HWRAC-18WSPA A24	1	TC-COVER
34	HWRAC-18WSPA A09	1	REAR-COVER
35	HWRAC-50WEB A04	1	TERMINAL COVER
36	HWRAC-18WSPA A10	1	TOP COVER
37	HWRAC-50NX2 A35	1	SERVICE VALVE COVER
38	HWRAC-50NX2 A36	1	BUSH ASSEMBLY
39	HWRAC-50NX2 A37	2	BUSH
40	HWRAC-50NX2 A38	1	DRAIN PIPE
41	HWRAC-50WEB A05	1	ELECTRIC PARTS PLATE
42	HWRAC-50WEB A06	1	ELECTRIC PARTS COVER
43	HWRAC-50WEB A07	1	SUPPORT (P. W. B.)
44	HWRAC-50WEB A08	1	HEAT SINK
45	HWRAC-50WEB A09	1	P. W. B. (MAIN)
46	HWRAC-50WEB A10	1	12 CORD ASSEMBLY
47	HWRAC-50WEB A11	1	CORD ASSEMBLY
48	HWRAC-18WEB A18	1	TERMINAL BOARD (5P)
49	HWRAC-50NX2 A51	1	FUSE (25A)
50	HWRAC-50NX2 A52	2	FUSE (3. 15A)
51	HWRAC-50WEB A12	1	BASE
52	HWRAC-50WEB A13	1	SUPPORT (P. W. B.)
53	HWRAC-50WEB A14	1	O. L. R COVER
54	HWRAC-50WEB A18	1	SOUND PROOF
55	HWRAC-50WEB A19	1	SOUND PROOF
56	HWRAC-50WEB A20	1	BUTYL

HITACHI

RAK-18PEB/RAC-18WEB
RAK-25PEB/RAC-25WEB
RAK-35PEB/RAC-35WEB
RAK-50PEB/RAC-50WEB
RAK-25PEBC /RAC-25WEB
RAK-35PEBC /RAC-35WEB
RAK-50PEBC /RAC-50WEB