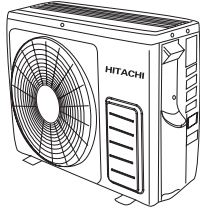


# HITACHI

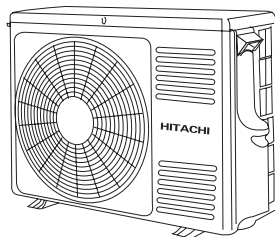
## SERVICE MANUAL TECHNICAL INFORMATION

FOR SERVICE PERSONNEL ONLY

OUTDOOR UNIT



RAC-18WED  
RAC-25WED  
RAC-35WED



RAC-50WED

INDOOR UNIT



RAK-18PED  
RAK-25PED  
RAK-35PED  
RAK-50PED  
RAK-25PEDC  
RAK-35PEDC  
RAK-50PEDC



JCH-WH

NO. 0105E

RAK-18PED/RAC-18WED  
RAK-25PED/RAC-25WED  
RAK-35PED/RAC-35WED  
RAK-50PED/RAC-50WED  
RAK-25PEDC/RAC-25WED  
RAK-35PEDC/RAC-35WED  
RAK-50PEDC/RAC-50WED

### REFER TO THE FOUNDATION MANUAL CONTENTS

SPECIFICATIONS .....	6
HOW TO USE .....	9
CONSTRUCTION AND DIMENSIONAL DIAGRAM .....	18
MAIN PARTS COMPONENT .....	21
WIRING DIAGRAM .....	23
CIRCUIT DIAGRAM .....	25
BLOCK DIAGRAM .....	30
BASIC MODE .....	31
REFRIGERATING CYCLE DIAGRAM .....	41
PROCEDURE FOR DISASSEMBLY AND REASSEMBLY.....	44
DESCRIPTION OF MAIN CIRCUIT OPERATION .....	47
SERVICE CALL Q & A .....	74
TROUBLE SHOOTING .....	77
PARTS LIST AND DIAGRAM .....	109

### SPECIFICATIONS

TYPE	DC INVERTER									
	INDOOR UNIT	OUTDOOR UNIT	INDOOR UNIT	OUTDOOR UNIT	INDOOR UNIT	OUTDOOR UNIT	INDOOR UNIT	OUTDOOR UNIT		
MODEL	RAK-18PED	RAC-18WED	RAK-25PED RAK-25PEDC	RAC-25WED	RAK-35PED RAK-35PEDC	RAC-35WED	RAK-50PED RAK-50PEDC	RAC-50WED		
POWER SOURCE	1 PHASE,50Hz,220-230V		1 PHASE,50Hz,220-230V		1 PHASE,50Hz,220-230V		1 PHASE,50Hz, 220-230V			
COOLING	TOTAL INPUT (W)	580 (250 ~ 1,010)		700 (250~1,290)		1,090 (250~1,460)		1,560 (500~2,100)		
	TOTAL AMPERES (A)	3.19-3.05		3.84-3.67		5.41-5.18		7.16-6.85		
	CAPACITY	(KW)	2.00 (0.90~2.50)		2.50 (0.90~3.10)		3.50 (0.90~4.00)		5.00 (1.90~5.20)	
		(B.T.U./h)	6,820 (3,070~8,530)		8,530 (3,070~10,580)		11,940 (3,070~13,650)		17,060 (6,480~17,740)	
HEATING	TOTAL INPUT (W)	620 (250~970)		880 (250~1,250)		1,100 (250~1,700)		1,660 (500~2,750)		
	TOTAL AMPERES (A)	3.62-3.46		4.56-4.36		5.56-5.31		7.62-7.29		
	CAPACITY	(KW)	2.50 (0.90~3.20)		3.40 (0.90~4.40)		4.20 (0.90~5.00)		6.00 (2.20~7.30)	
		(B.T.U./h)	8,530 (3,070~10,920)		11,600 (3,070~15,010)		14,330 (3,070~17,060)		20,470 (7,510~24,910)	
DIMENSIONS (mm)	W	780	660(+60)*	780	660(+60)*	780	660(+60)*	780	792(+91)*	
	H	280	530	280	530	280	530	280	600	
	D	215	278(+55)*	215	278(+55)*	215	278(+55)*	215	299(+47)*	
NET WEIGHT (Kg)	7.5	23	7.5	23	7.5	24.5	8	39.5		

\* After installation

SPECIFICATIONS AND PARTS ARE SUBJECT TO CHANGE FOR IMPROVEMENT

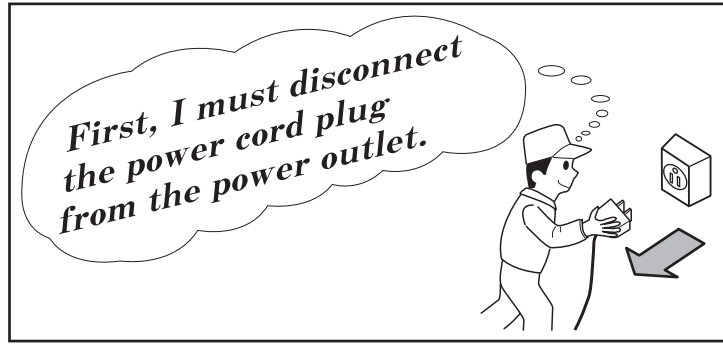
## ROOM AIR CONDITIONER

INDOOR UNIT + OUTDOOR UNIT

Johnson Controls-Hitachi Air Conditioning Wuhu Co., Ltd.

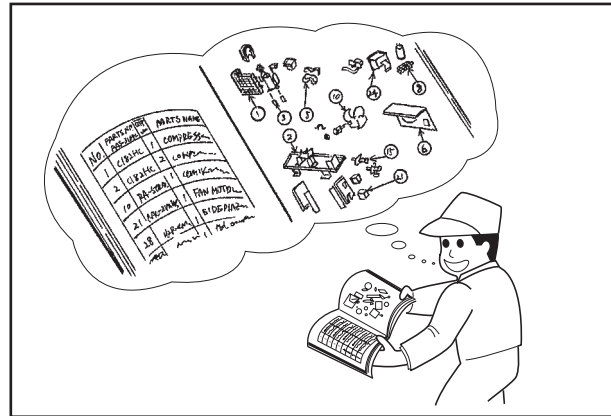
## SAFETY DURING REPAIR WORK

1. In order to disassemble and repair the unit in question, be sure to disconnect the power cord plug from the power outlet before starting the work.



2. If it is necessary to replace any parts, they should be replaced with respective genuine parts for the unit, and the replacement must be effected in correct manner according to the instructions in the Service Manual of the unit.

If the contacts of electrical parts are defective, replace the electrical parts without trying to repair them



3. After completion of repairs, the initial state should be restored.
4. Lead wires should be connected and laid as in the initial state.
5. Modification of the unit by the user himself should absolutely be prohibited.
6. Tools and measuring instruments for use in repairs or inspection should be accurately calibrated in advance.
7. In installing the unit having been repaired, be careful to prevent the occurrence of any accident such as electrical shock, leak of current, or bodily injury due to the drop of any part.
8. To check the insulation of the unit, measure the insulation resistance between the power cord plug and grounding terminal of the unit.  
The insulation resistance should be  $1M\Omega$  or more as measured by a 500V DC megger.
9. The initial location of installation such as window, floor or the other should be checked for being safe enough to support the repaired unit again.  
If it is found not so strong and safe, the unit should be installed at the initial location after reinforced or at a new location.

10. Any inflammable object must not be placed about the location of installation.
11. Check the grounding to see whether it is proper or not, and if it is found improper, connect the grounding terminal to the earth.



# WORKING STANDARDS FOR PREVENTING BREAKAGE OF SEMICONDUCTORS

## 1. Scope

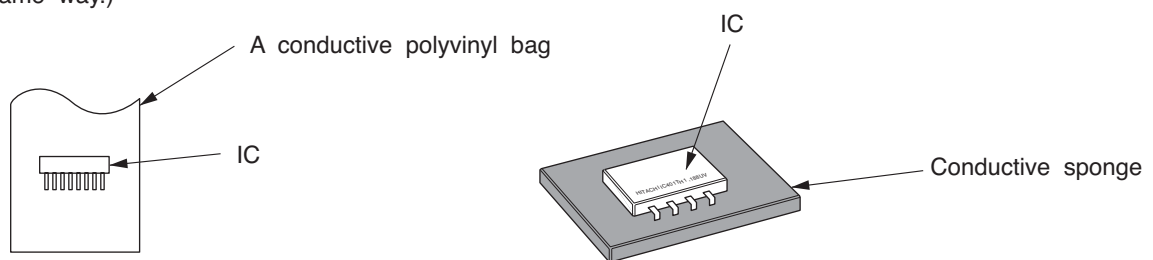
The standards provide for items to be generally observed in carrying and handling semiconductors in relative manufactures during maintenance and handling thereof. (They apply the same to handling of abnormal goods such as rejected goods being returned.)

## 2. Object parts

- (1) Microcomputer
- (2) Integrated circuits (I.C.)
- (3) Field effective transistor (F.E.T.)
- (4) P.C. boards or the like to which the parts mentioned in (1) and (2) of this paragraph are equipped.

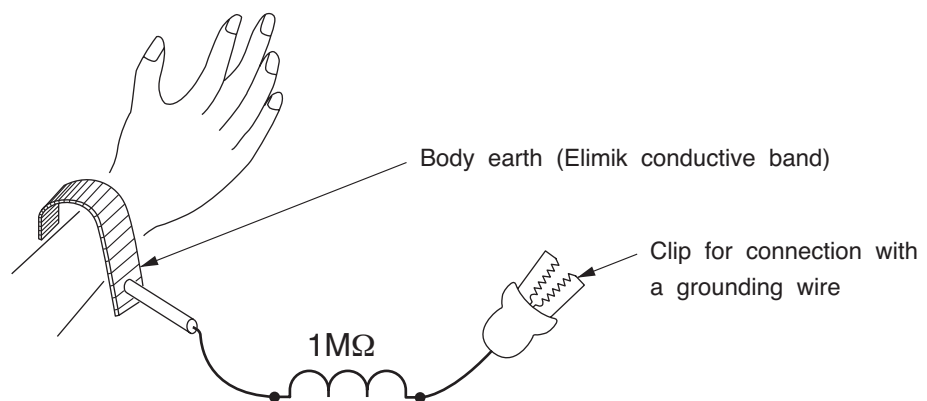
## 3. Items to be observed in handling

- (1) Use a conductive container for carrying and storing of parts. (Even rejected goods should be handled in the same way.)



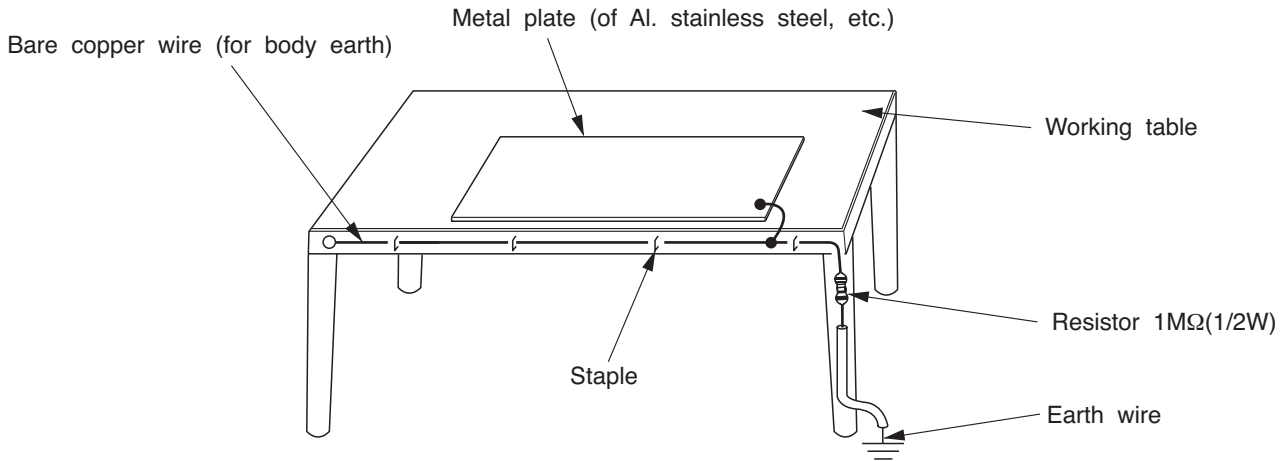
**Fig. 1 Conductive container**

- (2) When any part is handled uncovered (in counting, packing and the like), the handling person must always use himself as a body earth. (Make yourself a body earth by passing one M ohm earth resistance through a ring or bracelet.)
- (3) Be careful not to touch the parts with your clothing when you hold a part even if a body earth is being taken.
- (4) Be sure to place a part on a metal plate with grounding.
- (5) Be careful not to fail to turn off power when you repair the printed circuit board. At the same time, try to repair the printed circuit board on a grounded metal plate.

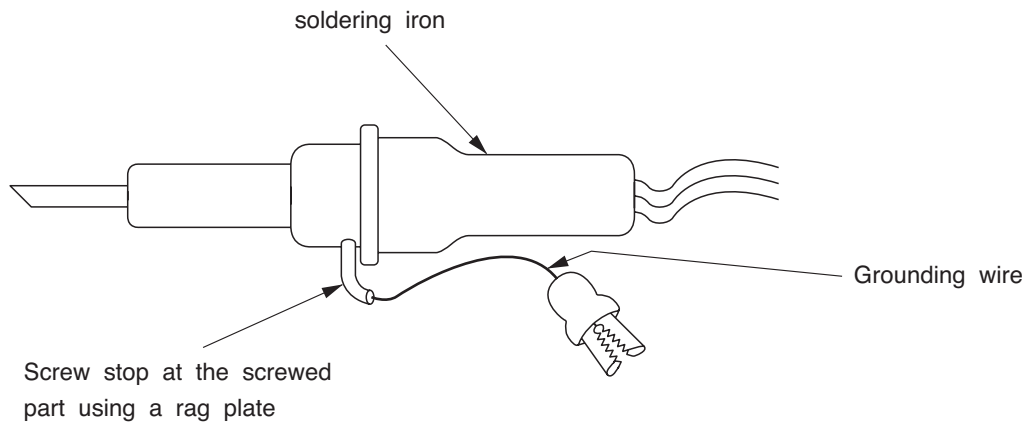


**Fig. 2 Body earth**

(6) Use a three wire type soldering iron including a grounding wire.



**Fig.3 Grounding of the working table**



**Fig.4 Grounding a solder iron**

Use a high insulation mode (100V, 10MΩ or higher) when ordinary iron is to be used.

(7) In checking circuits for maintenance, inspection, or some others, be careful not to have the test probes of the measuring instrument short circuit a load circuit or the like.

 **CAUTION**

1. In quiet or stop operation, slight flowing noise of refrigerant in the refrigerating cycle is heard occasionally, but this noise is not abnormal for the operation.
2. When it thunders near by, it is recommend to stop the operation and turn off the circuit breaker for safety.
3. In the event of power failure,the room air conditioner will restare automatically in the previously selected mode once the power is restored. In the event of power failure during TIMER operation, the room air comditioner will not start automatically. Re-press ON/OFF button after 3 minutes from when the unit off or power recovery.
4. If the room air conditioner is stopped by adjusting thermostat, or missoperation, and re-start in a moment, there is occasion that the cooling and heating operation does not start for 3 minutes, it is not abnormal and this is the result of the operation of IC delay circuit. This IC delay circuit ensures that there is no danger of blowing fuse or damaging parts even if operation is restarted accidentally.
5. This room air conditioner should not be used at the cooling operation when the outside temperature is below  $-10^{\circ}\text{C}$  ( $14^{\circ}\text{F}$ ).
6. This room air conditioner (the reverse cycle) should not be used when the outside temperature is below  $-15^{\circ}\text{C}$  ( $5^{\circ}\text{F}$ ).  
If the reverse cycle is used under this condition, the outside heat exchanger is frosted and efficiency falls.
7. When the outside heat exchanger is frosted, the frost is melted by operating the hot gas system, it is not trouble that at this time fan stops and the vapour may rise from the outside heat exchanger.

**SPECIFICATIONS**

MODEL	RAK-18PED RAK-25PED RAK-35PED RAK-50PED RAK-25PEDC RAK-35PEDC RAK-50PEDC	RAC-18WED RAC-25WED	RAC-35WED	RAC-50WED	
FAN MOTOR	30W (DC325V)	47W (DC120~380V)			
FAN MOTOR CAPACITOR	NO	NO			
FAN MOTOR PROTECTOR	NO	NO			
COMPRESSOR	-	GSD088SKQA6JK6	GTD130UKQA8JT6		
COMPRESSOR MOTOR CAPACITOR	NO	NO			
OVERLOAD PROTECTOR	NO	YES(INTERNAL)			
OVERHEAT PROTECTOR	NO	YES			
FUSE (for MICROPROCESSOR)	3.15A	15A, 2A, 3A, 3.15A	25A, 2A, 3A, 3.15A		
POWER RELAY	NO	HF161F			
POWER SWITCH	NO	NO			
TEMPORARY SWITCH	YES	NO			
SERVICE SWITCH	NO	YES			
TRANSFORMER	YES	YES			
VARISTOR	ERZVA9V431	TVR10471,ERZVA9V431			
NOISE SUPPRESSOR	NO	YES			
THERMOSTAT	YES(IC)	YES(IC)			
REMOTE CONTROL SWITCH (LIQUID CRYSTAL)	YES	NO			
REFRIGERANT CHARGING VOLUME (Refrigerant R32)	UNIT	-----	530g	700g	930g
	PIPES (MAX. 20m) (MIN. 3m)	WITHOUT REFRIGERANT BECAUSE COUPLING IS FLARE TYPE.			

Figure showing the installation of Indoor and Outdoor unit

MODEL RAK-18PED/RAC-18WED  
 RAK-25PED/RAC-25WED  
 RAK-35PED/RAC-35WED  
 RAK-25PEDC/RAC-25WED  
 RAK-35PEDC/RAC-35WED

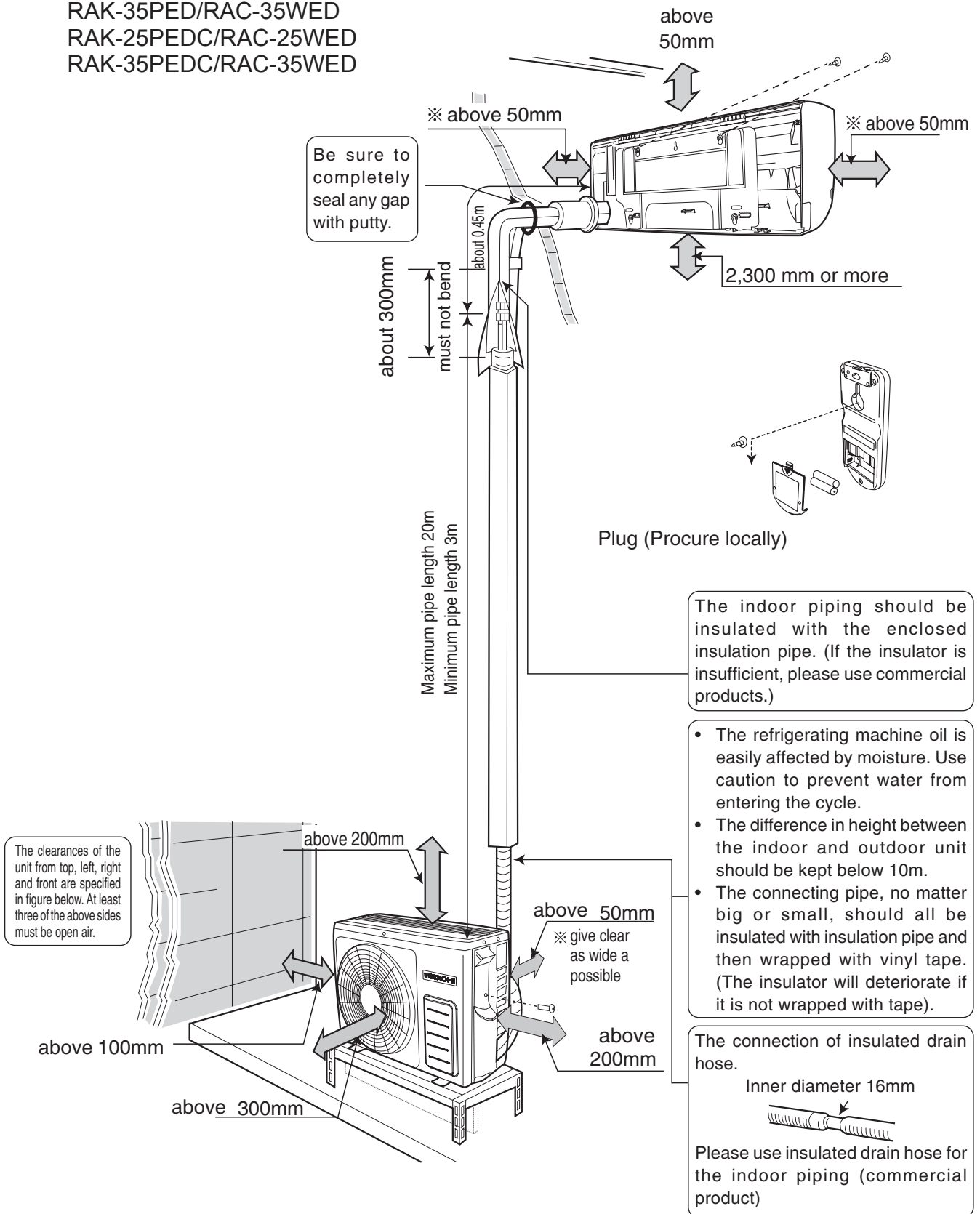
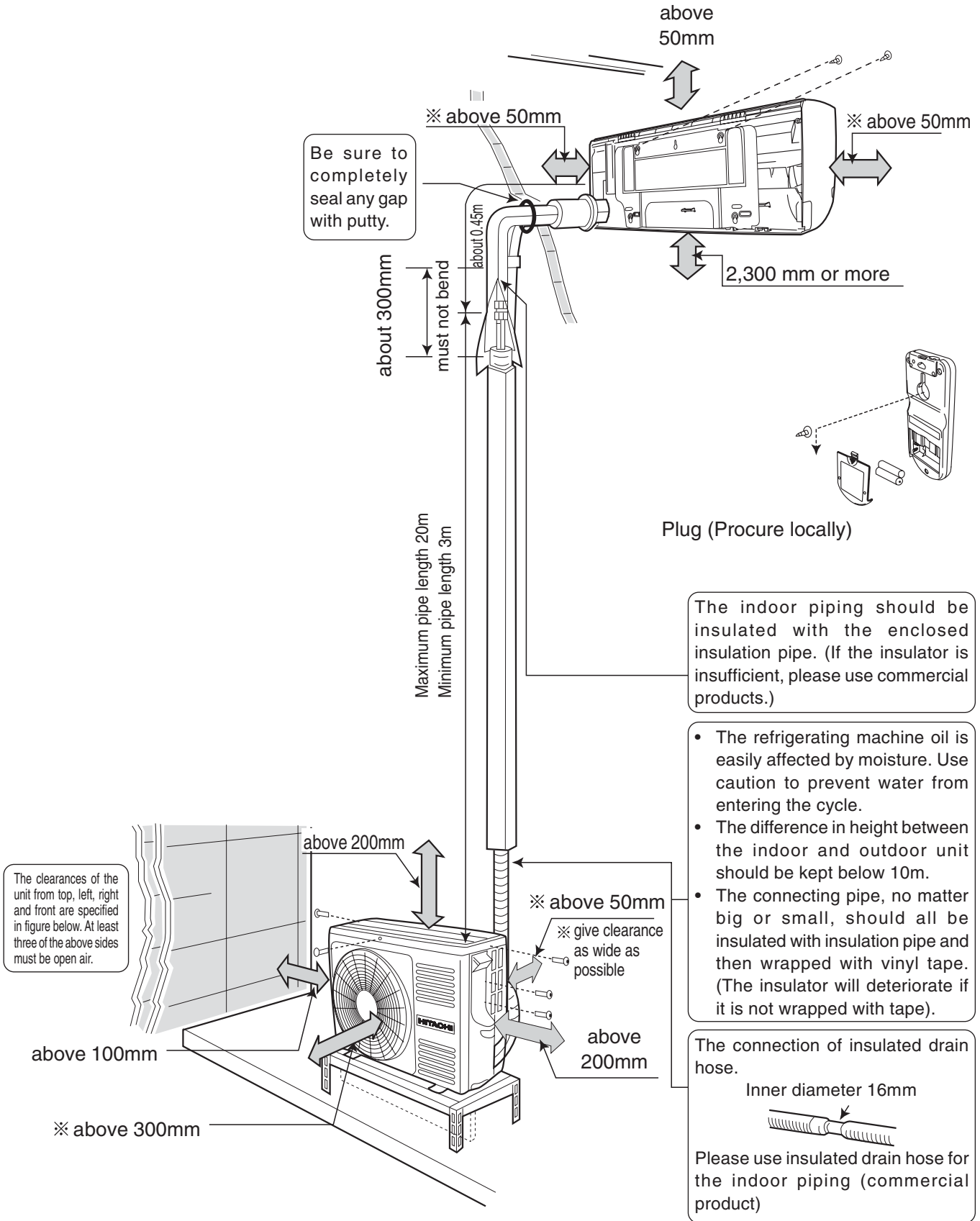


Figure showing the installation of Indoor and Outdoor unit

MODEL RAK-50PED/RAC-50WED  
RAK-50PEDC/RAC-50WED







## MANUAL OPERATION [Heating • Dehumidify • Cooling]

- Please use under below condition when you want to set the function mode, room temperature and fan speed manually.

HEATING	DEHUMIDIFYING	COOLING
Outdoor Temperature 24°C below	Room Temperature 16°C above	Outdoor Temperature 21°C above

### 1 OPERATION MODE SELECTION

- Every time you press the button, the mode will change as the below.



### 2 ROOM TEMPERATURE SETTING



- Recommend Temperature  
Heating 20-24°C  
Dehumidify 20-26°C  
Cooling 25-28°C

- The cooling operation does not start if the temperature setting is higher than the current room temperature.

### 3 FAN SPEED SETTING

- Every time you press the button, fan speed will change as below sequence.



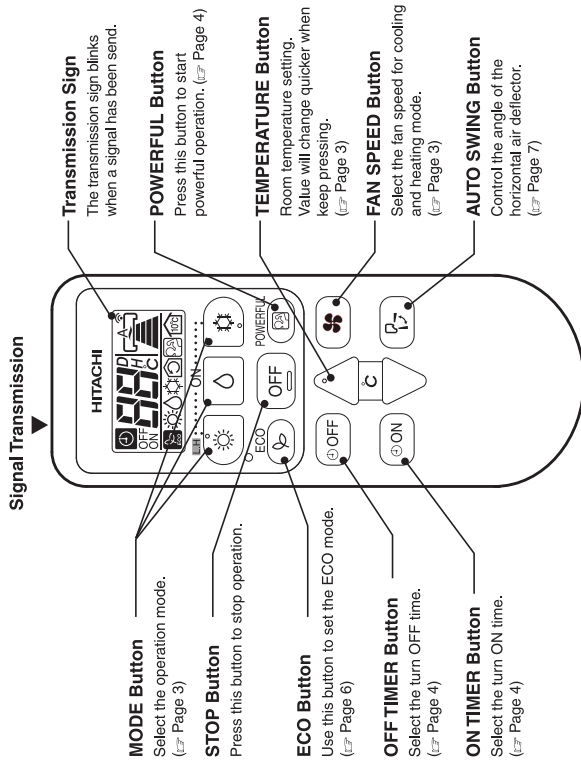
### 4 Press the OFF (STOP) button

- Operation stops with a beep.

## ENGLISH

## NAMES AND FUNCTIONS OF REMOTE CONTROLLER

- This controls the operation function and timer setting of the room air conditioner. The range of control is about 7 meters. If indoor lighting is controlled electronically, the range of control may be shorter.

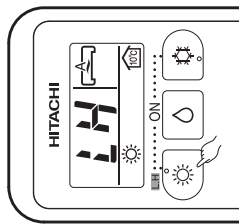


### Precautions for Use

- Do not put the remote controller under direct sunlight and high temperature.
- Do not drop it on the floor, and protect it from water.
- If you press the FUNCTION button during operation, the air conditioner may stop for about 3 minutes for protection before you can start it again.

## LEAVE HOME(LH) OPERATION

- Prevent the room temperature from falling too much by setting temperature at 10 deg automatically when no one is at home.



**START**

Hold down the HEATING Button for 3-5 seconds to start Leave Home operation.

- Room temperature is automatically set at 10 deg.
- " " LH " " " is displayed on the LCD.

**CANCEL**

Press the (STOP) button.  
Change to other Operation Mode.

### NOTE

- During Leave Home operation, fan speed and horizontal air deflector position cannot be changed.

## ENGLISH

## TIMER RESERVATION

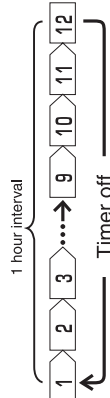
- ON Timer and OFF Timer are available.

### Timer Reservation

**1**

#### OFF TIME setting

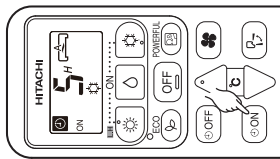
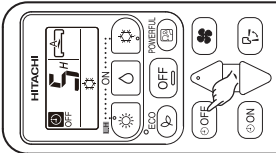
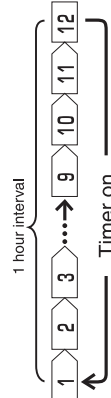
- Select the OFF TIME by pressing the (OFF) Button.
- Setting time will change according to the below sequence when you press the button.



**2**

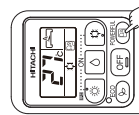
#### ON TIME setting

- Select the ON TIME by pressing the (ON) Button.
- Setting time will change according to the below sequence when you press the button.



## POWERFUL OPERATION

- By pressing (POWERFUL) button during HEATING, DEHUMIDIFYING, COOLING operation, the air conditioner performs at maximum power.
- During POWERFUL operation, cooler or warmer air will be blown out from indoor unit for COOLING or HEATING operation respectively.



**START**

Press the (POWERFUL) button during operation.

- " " is displayed on the LCD.
- During POWERFUL operation, capacity of the air conditioner will not increase automatically operates with the previous settings used before POWERFUL operation.

**CANCEL**

Press the (POWERFUL) button again.  
" " disappears from the LCD.

### NOTE

- When ECO mode, or LEAVE HOME mode is selected, POWERFUL operation is cancelled.
- During POWERFUL operation, capacity of the air conditioner will not increase
  - if the air conditioner is already running at maximum capacity.
  - just before defrost operation (when the air conditioner is running in HEATING operation).
- After auto restart, POWERFUL operation is cancelled and previous operation shall start.



## ADJUSTING THE AIRFLOW DIRECTION

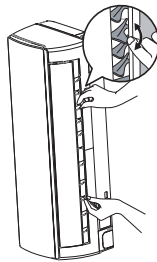
- 1 Adjust the airflow upward and downward. According to operation, the horizontal air deflector is automatically set to the proper angle suitable for each operation. The deflector can be swung up and down and also set to the desired angle using the " (AUTO SWING)" button.

- If the " (AUTO SWING)" button is pressed once, the horizontal air deflector swings up and down. If the button is pressed again, the deflector stops in its current position. Several seconds (about 6 seconds) may be required before the deflector starts to move.
- When the operation is stopped, the horizontal air deflector moves and stops at the position where the air outlet closes.

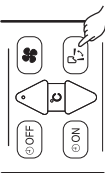
### CAUTION

- In "Cooling" operation, do not keep the horizontal air deflector swinging for a long time. Some dew may form on the horizontal air deflector and some dew may drop from it.

- 2 Adjust the airflow to left and right. Hold the vertical air deflector as shown on the right and adjust the airflow to left and right.

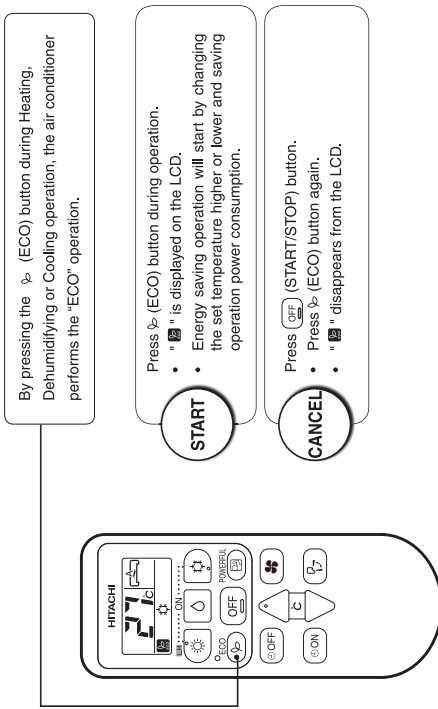


## ENGLISH



## ECO OPERATION

- Energy saving operation by changing set temperature and by limiting the maximum power consumption value.



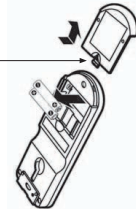
### NOTE

- In case the power consumption is already low, ECO operation will not reduce the power consumption.
- By pressing (POWERFUL) button, ECO operation is cancelled.
- After auto restart, ECO operation is cancelled and previous operation mode shall start.

## HOW TO EXCHANGE THE BATTERIES IN THE REMOTE CONTROLLER

- 1 Remove the cover as shown in the figure and take out the old batteries.

Push and pull to the direction of arrow




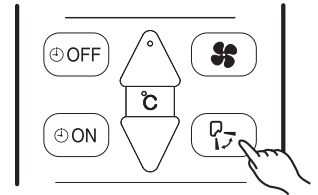
- 2 Install the new batteries. The direction of the batteries should match the marks in the case.


### CAUTION

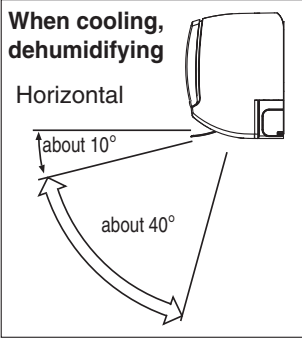
1. Do not use new and old batteries, or different kinds of batteries together.
2. Take out the batteries when you do not use the remote controller for 2 or 3 months.

# ADJUSTING THE AIRFLOW DIRECTION

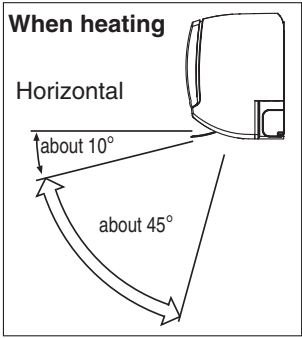
- 1** Adjust the airflow upward and downward.  
According to operation, the horizontal air deflector is automatically set to the proper angle suitable for each operation. The deflector can swing up and down and also be set to the desired angle using the “ (AUTO SWING)” button.



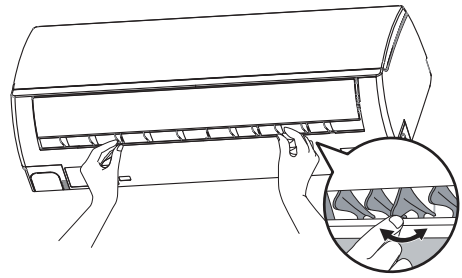
- If the “ (AUTO SWING)” button is pressed once, the horizontal air deflector swings up and down. If the button is pressed again, the deflector stops in its current position. Several seconds (about 6 seconds) may be required before the deflector starts to move.
- The adjusting range of the horizontal air deflector is shown on the right.
- When the operation is stopped, the horizontal air deflector moves and stops at the position where the air outlet closes.

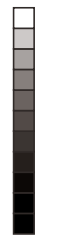


- ⚠ CAUTION**
- In “Cooling” operation, do not keep the horizontal air deflector swinging for a long time. Some dew may form on the horizontal air deflector and some dew may drop from it.



















- 2** Adjust the airflow to left and right.  
Hold the vertical air deflector as shown on the right and adjust the airflow to left and right.









ENGLISH









PRECAUTIONS DURING OPERATION

<b>CAUTION</b>		• The product shall be operated under the manufacturer specification and not for any other intended use.
		• Do not attempt to operate the unit with wet hands, this could cause fatal accident.
		• When operating the unit with burning equipments, regularly ventilate the room to avoid oxygen insufficiency.
		• Do not direct the cool air coming out from the air-conditioner panel to face household heating apparatus as this may affect the working of apparatus such as the electric kettle, oven etc.
		• Please ensure that outdoor mounting frame is always stable, firm and without defect. If not, the outdoor unit may collapse and cause danger.
		• Do not wash the unit with water or place a water container such as a vase on the indoor unit. Electrical leakage could be present and cause electric shock.
		• Do not place plants directly under the airflow as it is bad for the plants.
		• Be sure to stop the operation by using the remote controller, and turn off the circuit breaker during cleaning, the high-speed fan inside the unit may cause danger.
		• Turn off the circuit breaker if the unit is not be operated for a long period.
		• Do not climb on the outdoor unit or put objects on it.
<b>WARNING</b>		• When operating the unit with the door and windows opened, (the room humidity is always above 80%) and with the air deflector facing down or moving automatically for a long period of time, water will condense on the air deflector and drips down occasionally. This will wet your furniture. Therefore, do not operate under such condition for a long time.
		• If the amount of heat in the room is above the cooling or heating capability of the unit (for example: more people entering the room, using heating equipments and etc.), the preset room temperature cannot be achieved.
		• Indoor unit cleaning must be performed by authorized personnel only. Consult your sales agent. Using a commercially available detergent or similar can damage the plastic parts or clog the drain pipe, causing water to drip with potential electric shock hazard.
		• Do not touch the air outlet, bottom surface and aluminium fin of the outdoor unit. You may get hurt.
		• Do not touch the refrigerant pipe and connecting valve. Burns may result.
		• This appliance is not to be used by children or persons with reduced physical, sensory or mental capabilities, or lack of experience and knowledge, unless they have been given supervision or instruction. Children must be supervised not to play with the appliance.





SAFETY PRECAUTION

-  This appliance is filled with R32.
- Please read the "Safety Precaution" carefully before operating the unit to ensure correct usage of the unit.
- Pay special attention to signs of "Warning" and "Caution". The "Warning" section contains matters which, if not observed strictly, may cause death or serious injury. The "Caution" section contains matters which may result in serious consequences if not observed properly. Please observe all instructions strictly, to ensure safety.
- The signs indicate the following meanings. (The following are examples of signs.)
-  Make sure to connect earth line.
-  This sign in the figure indicates prohibition.
-  Indicates the instructions that must be followed.
- Please keep this manual after reading.







PRECAUTIONS DURING INSTALLATION

<b>WARNING</b>		• Do not reconstruct the unit. Water leakage, fault, short circuit or fire may occur if you reconstruct the unit by yourself.
		• Please ask your sales agent or qualified technician for the installation of your unit. Water leakage, short circuit or fire may occur if you install the unit by yourself.
<b>CAUTION</b>		• Please use earth line. Do not place the earth line near water or gas pipes, lightning-conductor, or the earth line of telephone. Improper installation of earth line may cause electric shock or fire.
		• Be sure to use the specified piping set for R32. <b>Otherwise, this may result in</b> broken copper pipes or faults. • Do not use refrigerant other than the one indicated on the outdoor unit (R32) when installing, moving or repairing. Using other refrigerants may cause trouble or damage to the unit, and personal injury.
<b>CAUTION</b>		• A circuit breaker should be installed depending on the mounting site of the unit. Without a circuit breaker, the danger of electric shock exists.
		• Do not install the unit near a location where there is flammable gas. The outdoor unit may catch fire if flammable gas leaks around it.
		• Please ensure smooth flow of water when installing the drain hose. • Make sure that a single phase, 220V-230V, power source is used. The use of other power sources may cause electrical components to overheat and lead to fire.
		

PRECAUTIONS DURING SHIFTING OR MAINTENANCE

<b>WARNING</b>		• Should abnormal situation arise (like burning smell), please stop operating the unit and turn off the circuit breaker. Contact your agent. Fault, short circuit or fire may occur if you continue to operate the unit under abnormal situation.
		• Please contact your agent for maintenance. Improper self maintenance may cause electric shock and fire.
<b>WARNING</b>		• Please contact your agent if you need to remove and reinstall the unit. Electric shock or fire may occur if you remove and reinstall the unit yourself improperly.
		

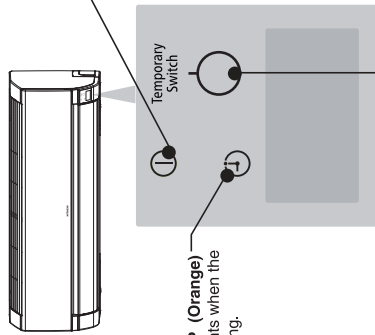
PRECAUTIONS DURING OPERATION

<b>WARNING</b>		• Avoid an extended period of direct airflow for your health.
		• Do not put objects like thin rods into the panel of blower and suction side because the high-speed fan inside may cause danger.
<b>WARNING</b>		• Do not use any conductor as fuse wire, this could cause fatal accident.
		• During thunder storm, disconnect the plug top and turn off the circuit breaker.
<b>WARNING</b>		• Spray cans and other combustibles should not be located within a meter of the air outlets of both indoor and outdoor units. As a spray can's internal pressure can be increased by hot air, a rupture may result.
		



## NAMES AND FUNCTIONS OF EACH PART

### INDOOR UNIT INDICATIONS



**OPERATION LAMP (Yellow)**  
This lamp lights during operation. The OPERATION LAMP flashes in the following cases during heating.

- (1) **During preheating**  
For about 2-3 minutes after starting up.
- (2) **During defrosting**  
Defrosting will be performed about once an hour when frost forms on the heat exchanger of the outdoor unit, for 5-10 minutes each time.

### TEMPORARY SWITCH

Use this switch to start and stop when the remote controller does not work.

- By pressing the temporary switch, the operation is done in automatic mode.
- When the operation is done using the temporary switch after the power source is turned off and turn on again, the operation is done in automatic mode.

### CAUTION

Turn off the circuit breaker if the unit is not operated for a long period.

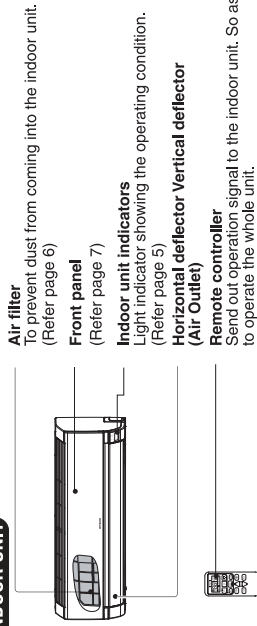
☆ If the power stays on and the unit is not operated, power is slightly consumed in the control circuit. The power is saved by turning off the power switch (or the circuit breaker when the power is supplied from the outdoor unit).

### OPERATING RANGE

Operation mode	Cooling / Dehumidifying	Heating
Outdoor temperature	-10 to 43°C	-15 to 21°C

## NAMES AND FUNCTIONS OF EACH PART

### INDOOR UNIT



**Air filter**  
To prevent dust from coming into the indoor unit. (Refer page 6)

**Front panel**  
(Refer page 7)

**Indoor unit indicators**  
Light indicator showing the operating condition. (Refer page 5)

**Horizontal deflector Vertical deflector (Air Outlet)**

**Remote controller**  
Send out operation signal to the indoor unit. So as to operate the whole unit.

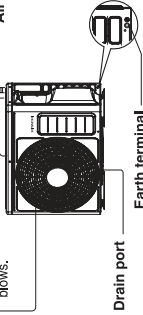
### OUTDOOR UNIT

**RAC-18WED**  
**RAC-25WED**  
**RAC-35WED**

**Air outlet**  
With "heating" operation is performed, cool air blows and when "cooling" or "dehumidifying" operation is performed, warm air blows.

**Drain hose**  
Drains the dehumidified water from the indoor unit to the outdoor during "cooling" or "dehumidifying" operation.

**Piping and Wiring**  
**Air inlets (Rear and left sides)**



**RAC-50WED**

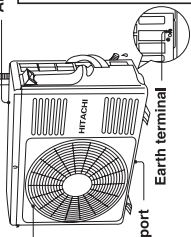
**Air outlet**  
When "heating" operation is performed, cool air blows and when "cooling" or "dehumidifying" operation is performed, warm air blows.

**Drain port**

**Earth terminal**

**Drain hose**  
Drains the dehumidified water from the indoor unit to the outdoor during "cooling" or "dehumidifying" operation.

**Piping and Wiring**  
**Air inlets (Rear and left sides)**



### About the outdoor unit:

- When "Stop" is selected during operation of the indoor unit, the fan of the outdoor unit continues turning for 10 to 60 seconds to cool the electric parts down.
- In heating operation, condensate or water may be discharged from the outdoor unit because the drain port of the outdoor unit is located in the chilly area.
- When the outdoor unit is hung on the wall, install the bush and drain pipe on the drain port and drain water.

### MODEL NAME AND DIMENSIONS

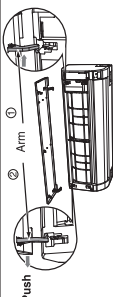
MODEL	WIDTH (mm)	HEIGHT (mm)	DEPTH (mm)
RAK-18/25/35/50PED, RAK-25/35/50PEDC	780	280	215
RAC-18/25/35WED	660	530	278
RAC-50WED	792	600	299

**2. CLEANING OF FRONT PANEL**

- Remove the front panel and wash with clean water. Wash it with a soft sponge. After using neutral detergent, wash thoroughly with clean water.
- When front panel is not removed, wipe it with a soft dry cloth. Wipe the remote controller thoroughly with a soft dry cloth.
- Wipe the water thoroughly. If water remains at indicators or signal receiver of indoor unit, it causes trouble.

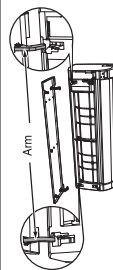
Method of removing the front panel. Be sure to hold the front panel with both hands to detach and attach it.

**Removing the Front Panel**



1. Push the end of the right-side arm outward to release the tab.
2. Move the left-side arm outward to release the left tab, and then pull the panel towards you.

**Attaching the Front Panel**



1. Insert the shaft of the left arm along the step on the unit into the hole.
2. Securely insert the shaft of the right arm along the step on the unit into the hole.
3. Make sure that the front panel is securely attached, and then close the front panel.

**CAUTION**

- Do not splash or direct water to the body of the unit when cleaning it as this may cause short circuit.
- Never use hot water (above 40°C), benzine, gasoline, acid, thinner or a brush, because they will damage the plastic surface and the coating.

**MAINTENANCE**





**CAUTION**

Cleaning and maintenance must be carried out only by qualified service personnel. Before cleaning, stop operation and switch off the power supply.

**1. AIR FILTER**

Please clean the filter once about every two weeks. By doing so, the power rates are saved. In case the air filter is full of dust, the air flow will decrease and the cooling capacity will be reduced. Further, noise may occur. Be sure to clean the filter following the procedure below.

**PROCEDURE**

1. Open the front panel carefully and remove the filter.
 
2. Vacuum dust from the air filter using vacuum cleaner. If there is too much dust, wash the filter with a detergent and rinse it thoroughly. After that, dry it in the shade.
 

3. Set the filter with "FRONT" mark facing front, and slot them into the original state.
 
  - After attaching the filters, push the front panel at three arrow portions as shown in figure and close it.

**CAUTION**

- Do not wash with hot water at more than 40°C. The filter may shrink.
- When washing it, shake off moisture completely and dry it in the shade; do not expose it directly to the sun. The filter may shrink.
- Don't operate the unit without filter. Fault may occur if you continue.



**REGULAR INSPECTION**

PLEASE CHECK THE FOLLOWING POINTS EVERY EITHER HALF YEARLY OR YEARLY. CONTACT YOUR SALES AGENT SHOULD YOU NEED ANY HELP.

 <b>WARNING</b>	<p>Check to see if the unit's earth line has been connected correctly. If the earth line is disconnected or faulty, unit failure or electric shock hazard may result.</p>
 <b>WARNING</b>	<p>Check to see if the mounting frame has rusted excessively or if the outdoor unit has tilted or become unstable. It could collapse or fall, causing injury.</p>

**AFTER SALES SERVICE AND WARRANTY**

CONDITION	CHECK THE FOLLOWING POINTS
<p>↑ If the remote controller is not transmitting a signal. (Remote controller display is dim or blank.)</p>	<ul style="list-style-type: none"> <li>Do the batteries need replacement?</li> <li>Is the polarity of the inserted batteries correct?</li> </ul>
<p>↑ When it does not operate.</p>	<ul style="list-style-type: none"> <li>Is the fuse all right?</li> <li>Is the voltage extremely high or low?</li> <li>Is the circuit breaker "ON"?</li> <li>Is the power plug inserted?</li> <li>Do you have any power cut?</li> </ul>
<p>↑ When it does not cool well. When it does not heat well.</p>	<ul style="list-style-type: none"> <li>Is the air filter blocked with dust?</li> <li>Is the set temperature suitable?</li> <li>Have horizontal air deflectors been adjusted to their correct positions according to the operation mode selected?</li> <li>Are the air inlets or air outlets of indoor and outdoor units blocked?</li> <li>Is the fan speed "LOW" or "SILENT"?</li> </ul>

■ The following phenomena do not indicate unit failure.

<p>&lt;Operation start&gt; During heating, the operation indicator blinks and air blow stops</p>	<p>The unit is preparing to blow warm air. Please wait. &lt;In operation&gt; The outdoor unit is defrosting. Please wait.</p>
<p>Hissing or fizzy sounds</p>	<p>Refrigerant flow noise in the pipe or valve sound generated when flow rate is adjusted.</p>
<p>Squeaking noise</p>	<p>Noise generated when the unit expands or contracts due to temperature changes.</p>
<p>Rustling noise</p>	<p>Noise generated with the indoor unit fan's rpm changing such as operation start times.</p>
<p>Clicking noise</p>	<p>Noise of the motorized valve when the unit is switched on.</p>

**INFORMATION**

**CAPABILITIES**

**Heating Capability**  
 This room air conditioner utilizes a heat pump system that absorbs exterior heat and brings it into a room to be heated. As the ambient temperature gets lower, heating capability will also lower. In such a situation, the inverter, work to increase compressor rpm to keep the unit's heating capability from decreasing. If the unit's heating performance is still unsatisfactory, other heating appliances should be used to augment this unit's performance.

**CAUTION**  
 Do not use a stove or any other high temperature devices in proximity to the indoor unit.

**Prohibition**

The air conditioner is designed to heat an entire room so that it may take some time before you feel warm. Timer operation is recommended for effective preheating ahead of the desired time.

**Cooling and Dehumidifying Capabilities**  
 If the heat present in a room exceeds the unit's cooling capacity (for example, if there are many people in the room or other heating appliances are used), the preset room temperature may not be reached.





Perking noise	Noise of the ventilation fan sucking in air present in the drain hose and blowing out dehumidifying water that had accumulated in the condensed water collector. For details, consult your sales agent.
Changing operation noise	Operation noise changes due to power variations according to room temperature changes.
Mist emission	Mist is generated as the air within the room is suddenly cooled by conditioned air.
Steam emitted from the outdoor unit	Water generated during defrosting operation evaporates and steam is emitted.
Odors	Caused as the smells and particles of smoke, food, cosmetics, etc. present in room air become attached to the unit and blown off into the room again.
The outdoor unit continues to operate even if operation is stopped.	Defrosting is underway (as the heating operation is stopped, the microcomputer checks frost accumulated in the outdoor unit and instructs the unit to perform automatic defrosting if necessary).
The OPERATION lamp is blinking.	Shows preheating or defrosting operation is underway. As the protective circuit or preheat sensor operates when unit operation is stopped during preheating and then restarted, or when operation mode is switched from cooling to heating, the lamp continues to blink.
Does not reach the temperature setting	Actual room temperature may deviate slightly from the remote controller's temperature setting depending on the number of people in the room, indoor or outdoor conditions.

- If the unit still fails to operate normally after performing the above inspections, turn the circuit breaker off and contact your sales agent immediately.

Contact your sales agent immediately if the following phenomena should occur

- The circuit breaker switches off or the fuse blows frequently.
  - The switch operation is not stable.
  - Foreign matter or water accidentally enters the unit interior.
  - The power cord gets excessively hot or its insulation is torn or stripped.
  - TIMER lamp on the indoor unit display blinks.
- ( As the nature of the failure can be identified by the blinking cycle, check the blinking cycle before turning off the circuit breaker. )



Notes

- In quiet operation or stopping the running, the following phenomena may occasionally occur, but they are not abnormal for the operation.
  - (1) Slight flowing noise of refrigerant in the refrigerating cycle.
  - (2) Slight rubbing noise from the fan casing which is cooled and then gradually warmed as operation stops.
- The odor will possibly be emitted from the room air conditioner because the various odor, emitted by smoke, foodstuffs, cosmetics and so on, sticks to it. So please clean the air filter and the evaporator regularly to reduce the odor.

- Please contact your sales agent immediately if the air conditioner still fails to operate normally after the above inspections. Inform your agent of the model of your unit, production number, date of installation. Please also inform him regarding the fault.

Please note:

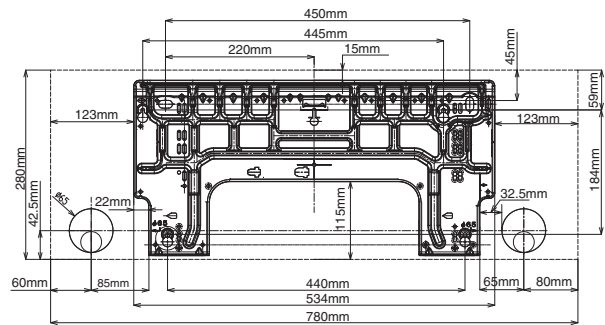
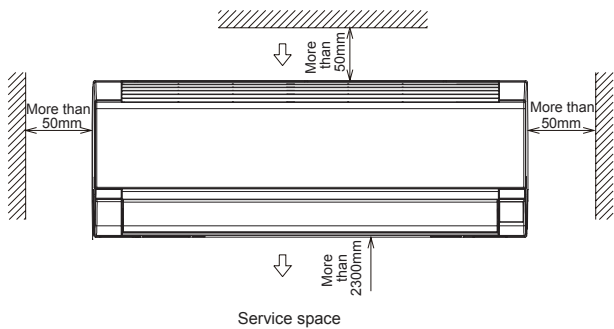
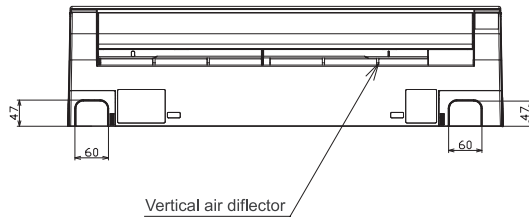
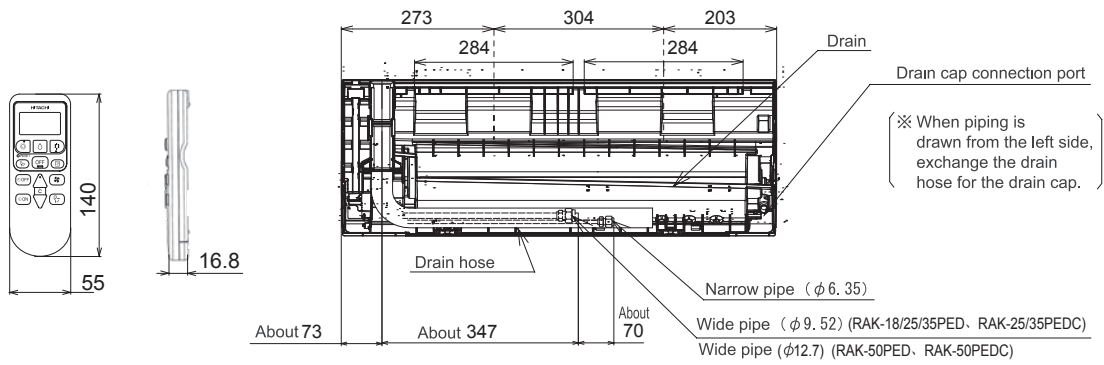
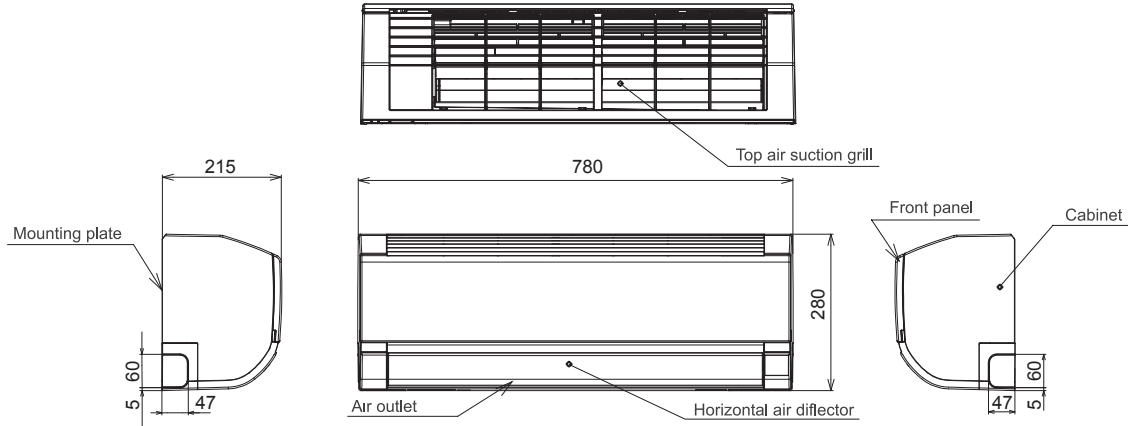
On switching on the equipment, particularly when the room light is dimmed, a slight brightness fluctuation may occur. This is of no consequence.  
The conditions of the local Power Supply Companies are to be observed.

# CONSTRUCTION AND DIMENSIONAL DIAGRAM

MODEL RAK-18PED, RAK-25PED, RAK-35PED, RAK-50PED  
 RAK-25PEDC, RAK-35PEDC, RAK-50PEDC

INDOOR UNIT

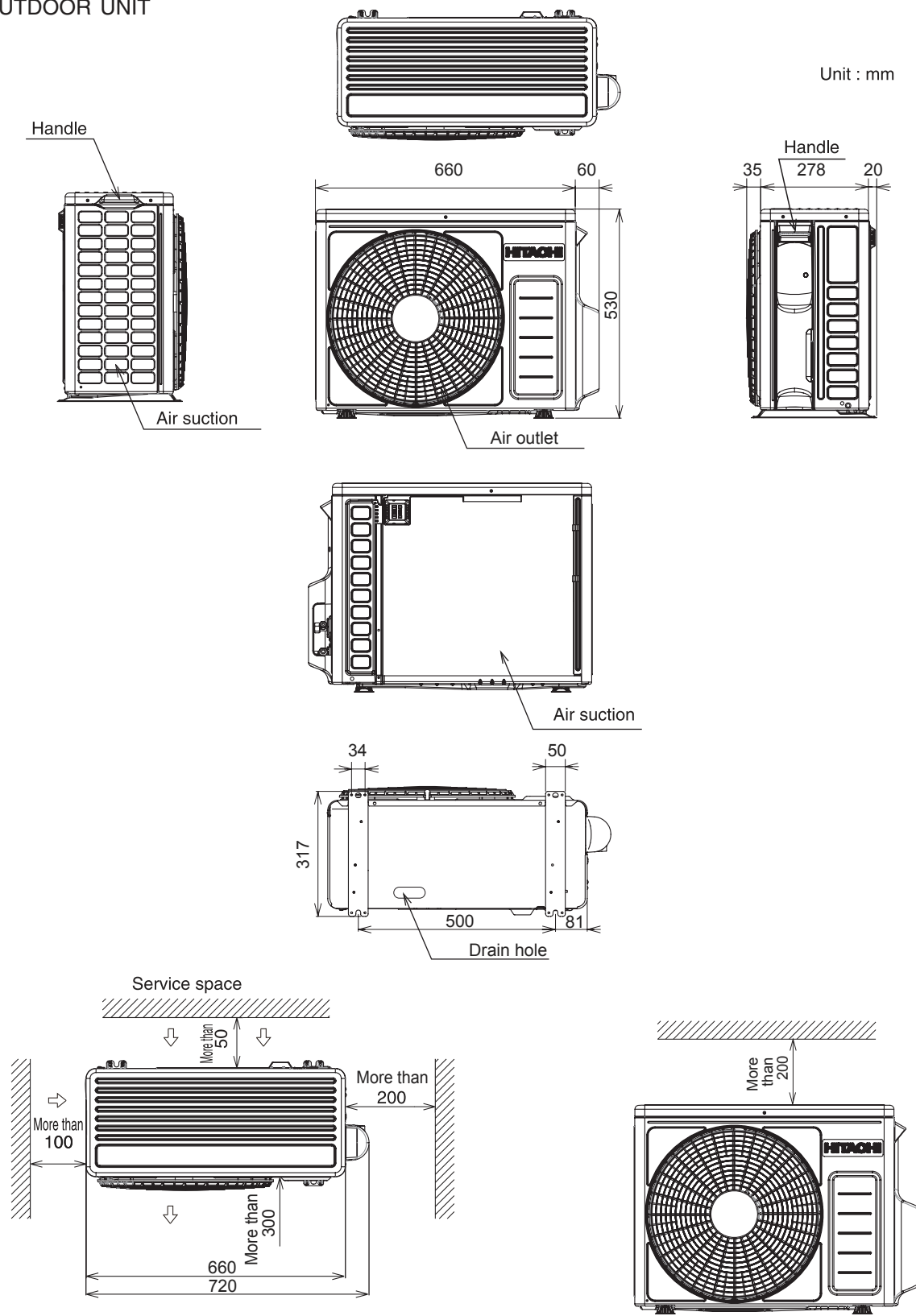
Unit : mm



# CONSTRUCTION AND DIMENSIONAL DIAGRAM

MODEL RAC-18WED, RAC-25WED, RAC-35WED

## OUTDOOR UNIT



### NOTE:

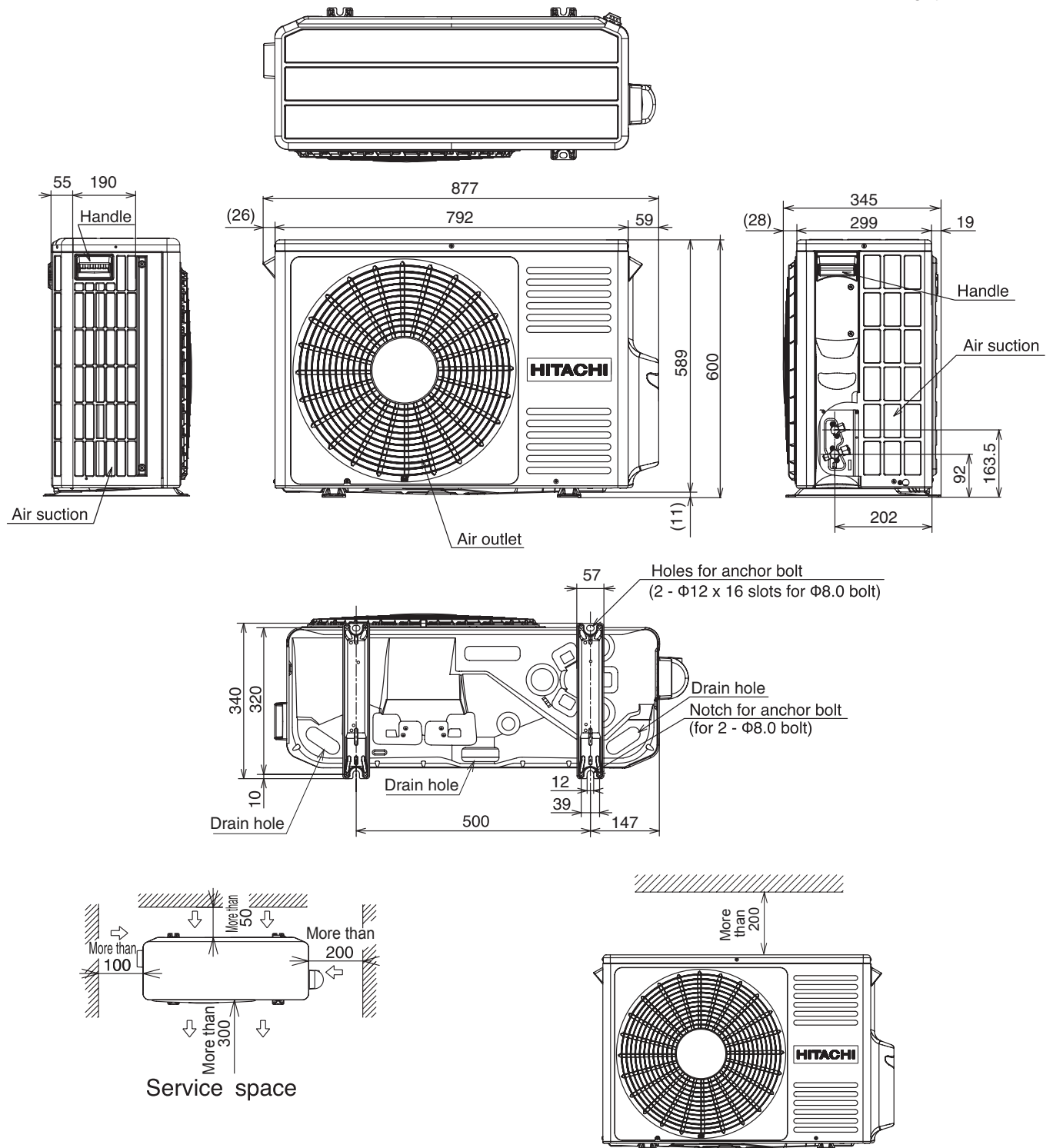
1. For outdoor unit installation, allow at least 2 sides of space around the unit ensure ventilation flue.
2. The connecting pipe, should all the insulated with insulation pipe.
3. Piping length is within 20m.
4. Height different of the piping between the indoor unit and outdoor unit should be within 10m.

# CONSTRUCTION AND DIMENSIONAL DIAGRAM

MODEL RAC-50WED

OUTDOOR UNIT

Unit : mm



**NOTE:**

1. For outdoor unit installation, allow at least 2 sides of space around the unit ensure ventilation flue.
2. The connecting pipe, should all the insulated with insulation pipe.
3. Piping length is within 20m.
4. Height different of the piping between the indoor unit and outdoor unit should be within 10m.

## MAIN PARTS COMPONENT

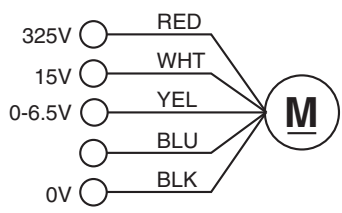
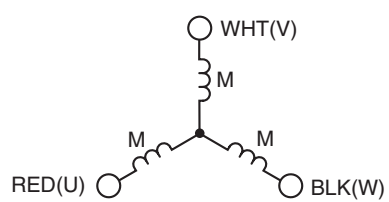
THERMOSTAT (Room temperature Thermistor)

### Thermostat Specifications

MODEL			RAK-18/25/35/50PED RAK-25/35/50PEDC		
THERMOSTAT MODEL			IC		
OPERATION MODE			COOL		HEAT
TEMPERATURE °C (°F)	INDICATION 16	ON	15.3	(59.54)	16.7 (62.06)
		OFF	15.0	(59.00)	16.7 (62.06)
	INDICATION 24	ON	23.3	(73.94)	24.7 (76.46)
		OFF	23.0	(73.40)	24.7 (76.46)
	INDICATION 32	ON	31.3	(88.34)	32.7 (90.86)
		OFF	31.0	(87.80)	32.7 (90.86)

## FAN MOTOR

### Fan Motor Specifications

MODEL	RAK-18/25/35/50PED RAK-25/35/50PEDC	RAC-18/25/35/50WED
POWER SOURCE	DC : 325V	DC : 120 - 380V
OUTPUT	30W	47W
CONNECTION	 <p>(Control circuit built in)</p>	

BLU : BLUE  
GRY : GRAY  
BLK : BLACK

YEL : YELLOW  
ORN : ORANGE  
PNK : PINK

BRN : BROWN  
GRN : GREEN  
VIO : VIOLET

WHT : WHITE  
RED : RED

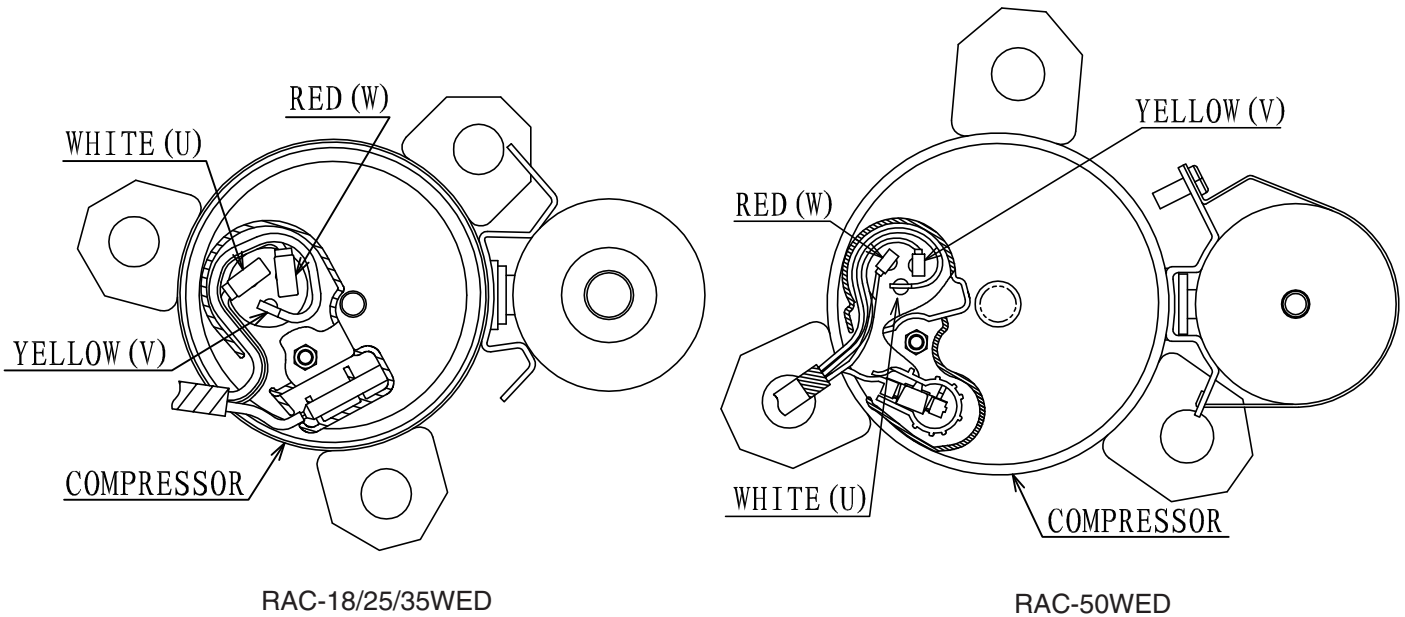
## MAIN ELECTRIC COMPONENTS FOR OUTDOOR UNIT

PARTS NAME	RESISTANCE VALUE(Ω)	APPLICABLE MODELS
COIL(REVERSING VALVE)	1470 Ω (20 °C)	RAC-18/25/35/50WED
COIL(EXPANSION VALVE)	46 Ω/PHASE (AT 20 °C)	RAC-18/25/35/50WED
REACTOR	15 (mH) 226 mΩ MAX (20 °C)	RAC-18/25/35WED
	5.3 (mH) 67 m Ω MAX (20 °C)	RAC-50WED

# COMPRESSOR MOTOR

## Compressor Motor Specifications

MODEL		RAC-18/25/35WED	RAC-50WED
COMPRESSOR TYPE		GSD088SKQA6JK6	GTD130UKQA8JT6
POWER SOURCE		220 - 350 V	220 - 350 V
OUTPUT		840W	1350W
CONNECTION			
RESISTANCE VALUE ( $\Omega$ )	20°C	2M= 2.167	2M= 1.354
	75°C	—	—



### CAUTION

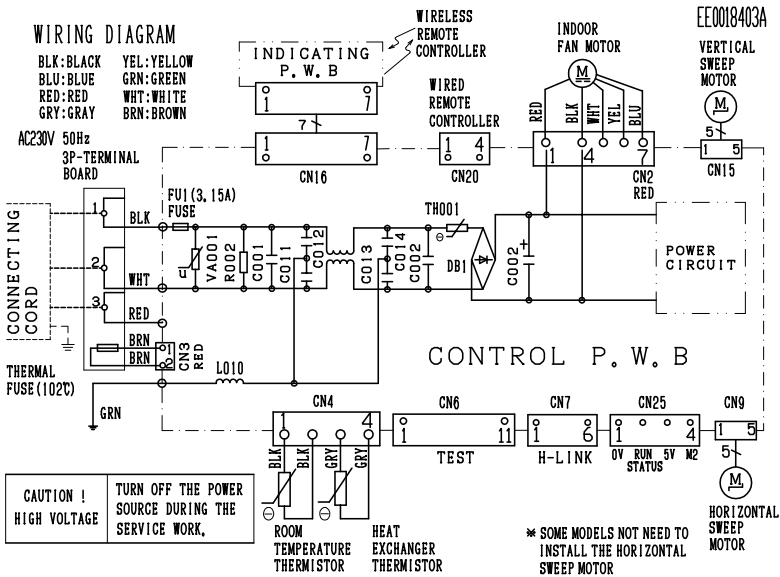
When the refrigerating cycle has been operated for a long time with the capillary tubes clogged or crushed or with too little refrigerant, check the color of the refrigerating machine oil inside the compressor. If the color has been changed conspicuously, replace the compressor.

**WIRING DIAGRAM**

INDOOR UNIT

MODEL RAK-18/25/35/50PED  
RAK-25/35/50PEDC

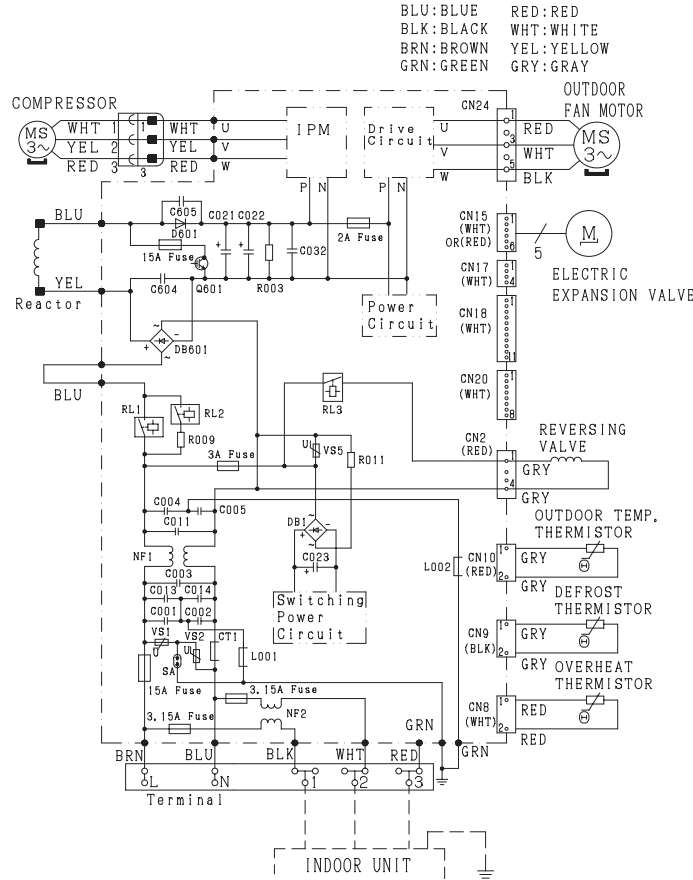
WIRING DIAGRAM



OUTDOOR UNIT

MODEL RAC-18/25/35WED

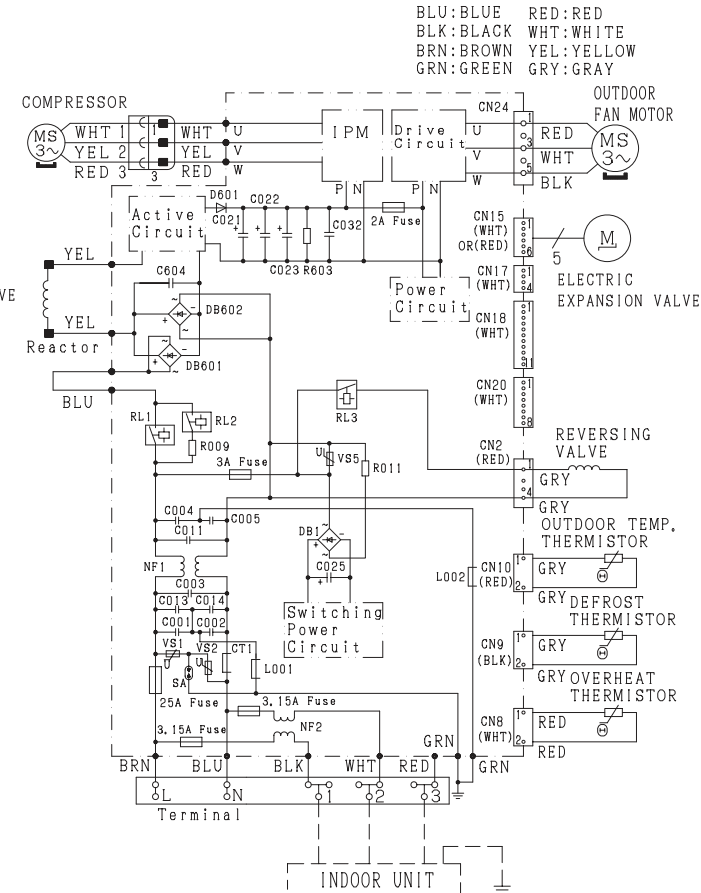
WIRING DIAGRAM



OUTDOOR UNIT

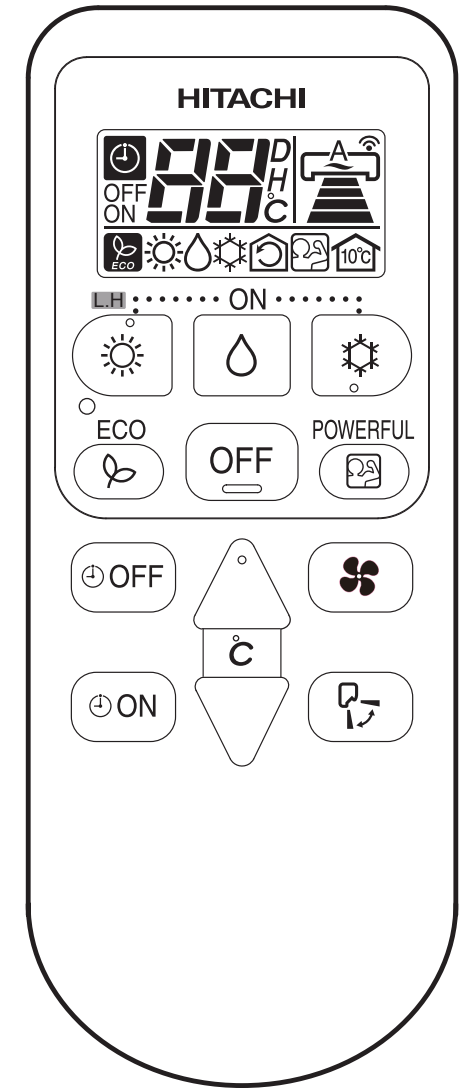
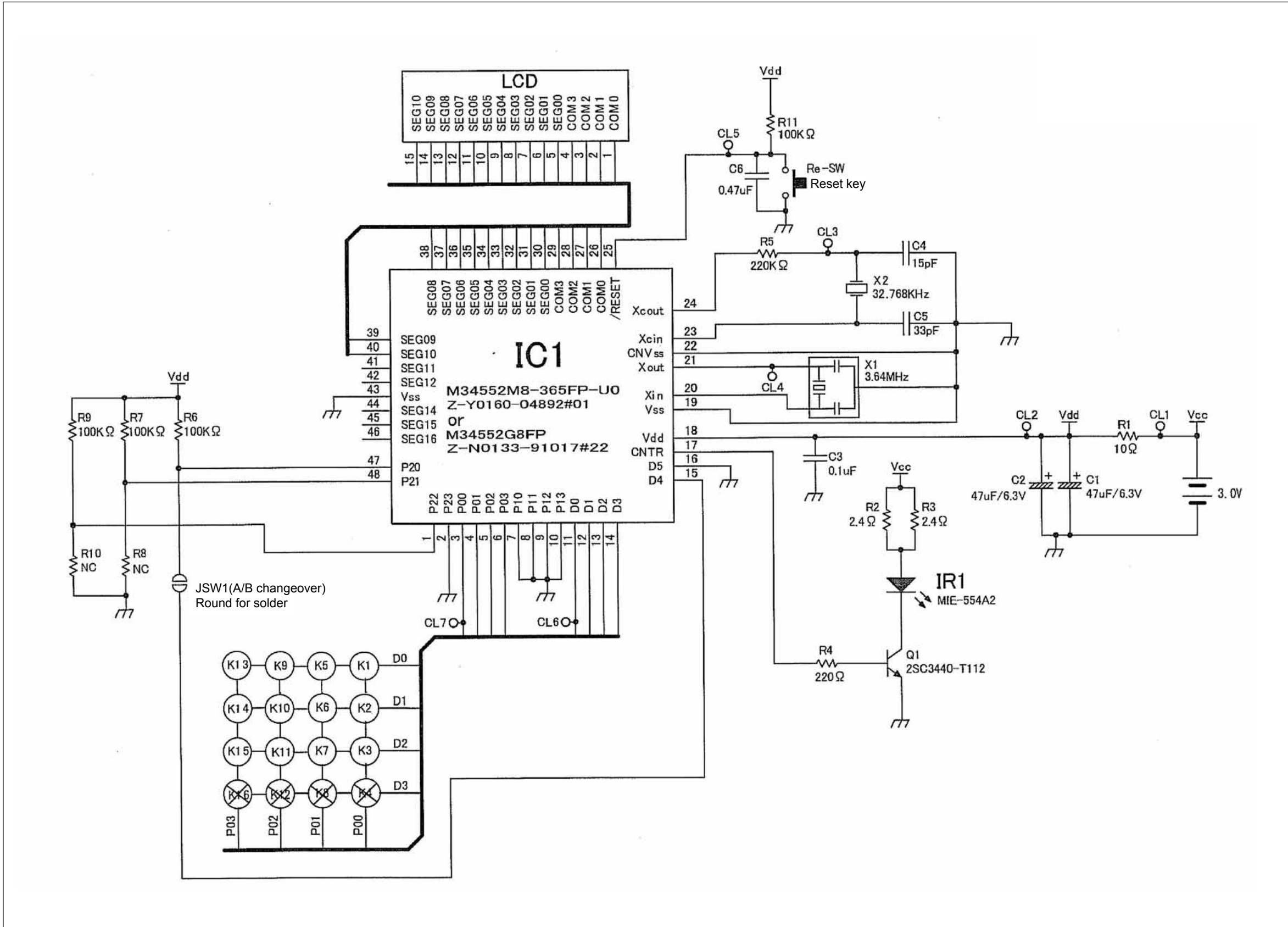
MODEL RAC-50WED

WIRING DIAGRAM



WIRING DIAGRAM OF THE PRINTED WIRING BOARD

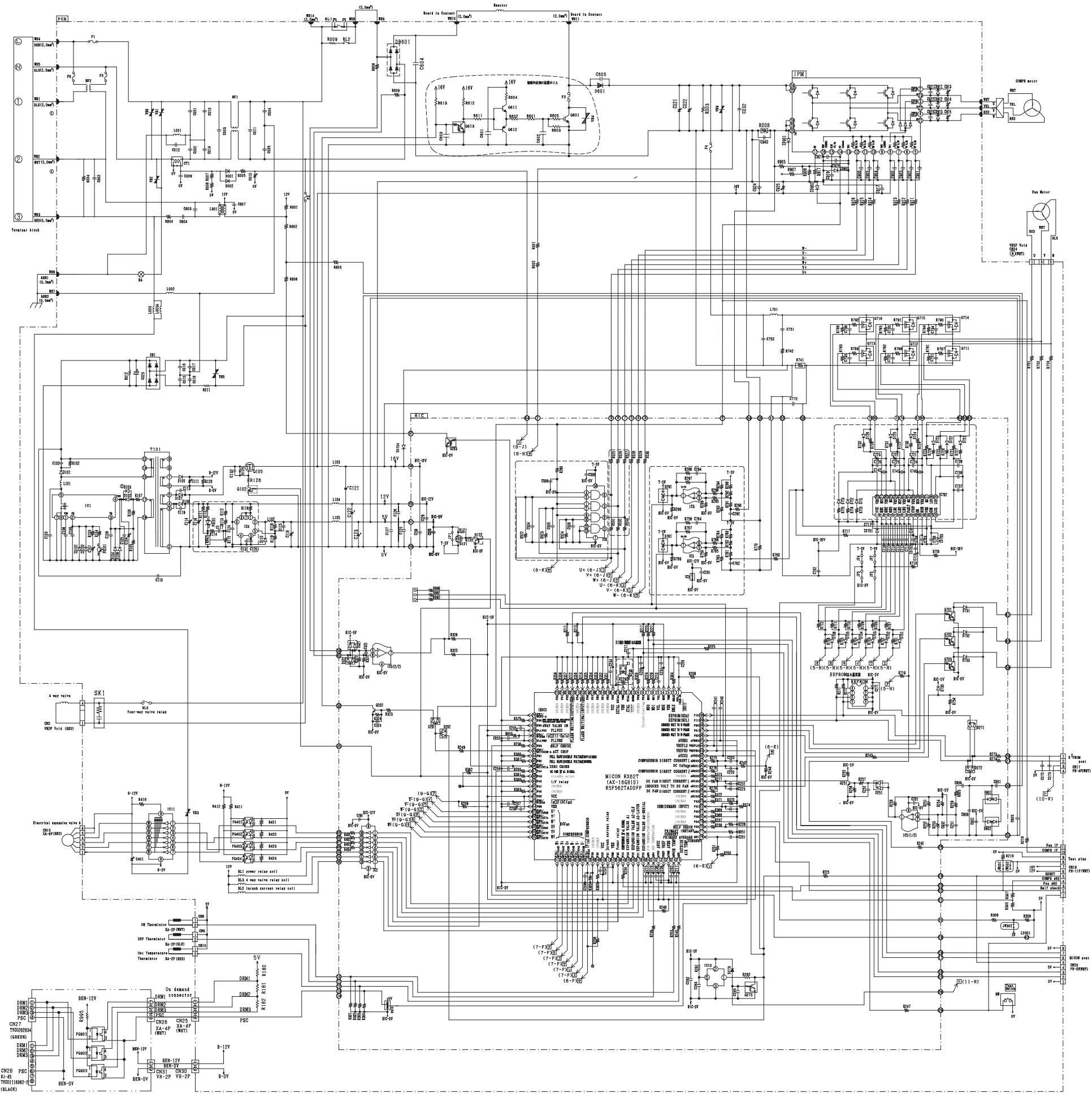
[Remote controller] RAR-5F1-1





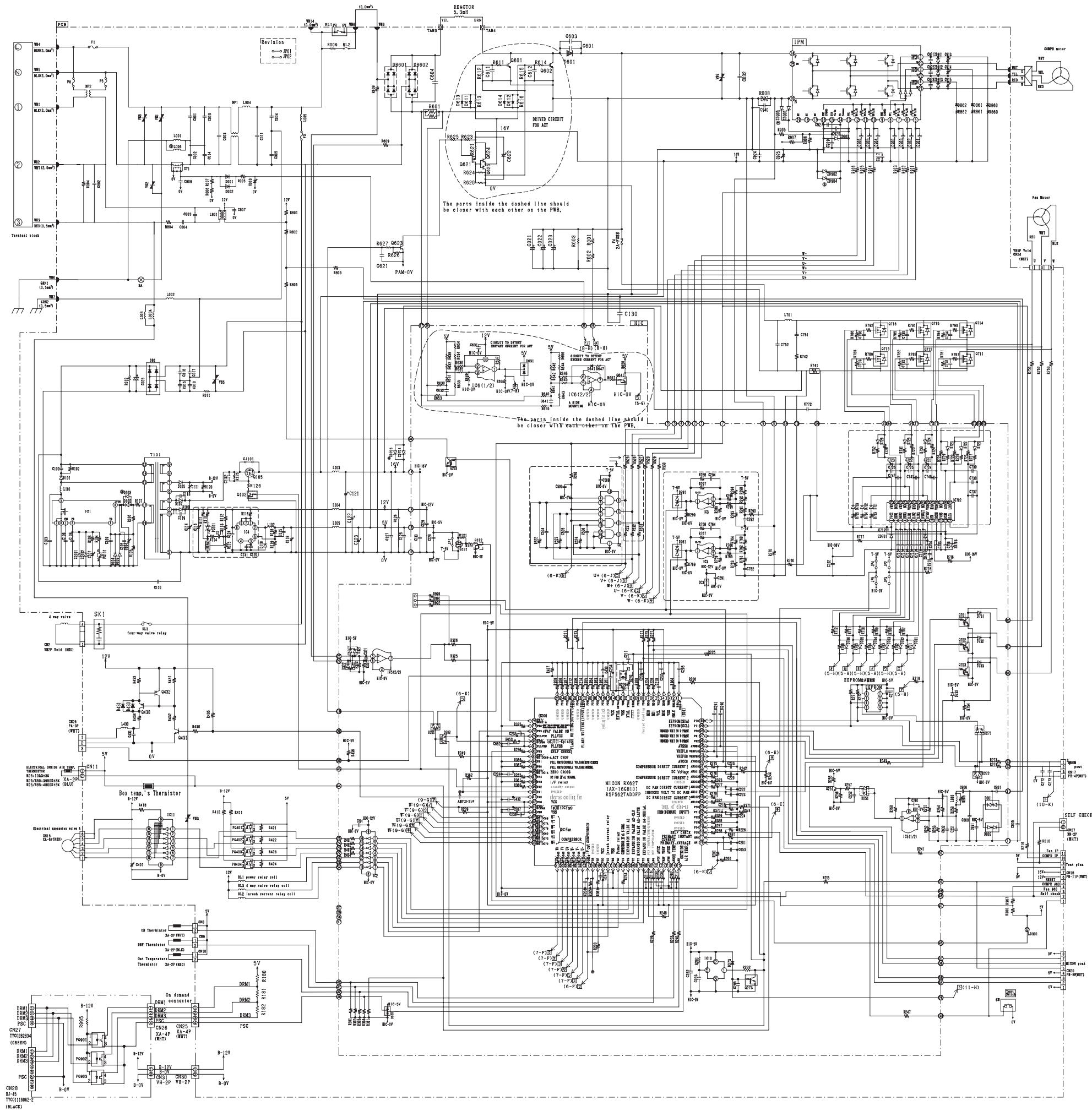


MODEL RAC-18/25/35WED





MODEL RAC-50WED



Mounting PCB  
M: Main PCB (BOARD-AS)

MAIN P. C. B

Way of mount mark  
A: Axial Insertion  
R: Radial Insertion (See pin)

Resistance

Table of Resistance components with columns for Symbol, Rating, and Remarks. Includes components like R001, R002, R004, etc.

Capacitor

Table of Capacitor components with columns for Symbol, Rating, and Remarks. Includes components like C102, C103, C104, etc.

LED

Table of LED components with columns for Symbol, Type, and Remarks. Includes component LB301.

Diode

Table of Diode components with columns for Symbol, Type, and Remarks. Includes components D101, D102, D103, etc.

Zener diode

Table of Zener diode components with columns for Symbol, Type, and Remarks. Includes components ZD01, ZD02, ZD03, etc.

Transistor

Table of Transistor components with columns for Symbol, Type, and Remarks. Includes components Q102, Q105, Q106, etc.

IC

Table of IC components with columns for Symbol, Type, and Remarks. Includes components IC1, IC2, IC3, etc.

Inductor

Table of Inductor components with columns for Symbol, Type, and Remarks. Includes components L001, L002, L003, etc.

Surge absorbers

Table of Surge absorbers components with columns for Symbol, Type, and Remarks. Includes components VS1, VS2, VS3, etc.

Coupler

Table of Coupler components with columns for Symbol, Type, and Remarks. Includes components P010, P0401, P0402, etc.

Relay

Table of Relay components with columns for Symbol, Type, and Remarks. Includes components RL1, RL2, RL3, etc.

Fuse

Table of Fuse components with columns for Symbol, Type, and Remarks. Includes components F1, F3, F4, F5, F6, etc.

Fuse Clip

Table of Fuse Clip components with columns for Symbol, Type, and Remarks. Includes components FC1, FC2, FC3, etc.

Connector

Table of Connector components with columns for Symbol, Type, and Remarks. Includes components CN2, CN9, CN10, etc.

Switch

Table of Switch components with columns for Symbol, Type, and Remarks. Includes component SW1.

Jumper

Table of Jumper components with columns for Symbol, Exist/No, and Remarks. Includes components JP1, JP2, etc.

250TAB

Table of 250TAB components with columns for Symbol, Dwg./No, and Remarks. Includes components TAB3, TAB4, etc.

HIC P. C. B

Resistance

Table of Resistance components for HIC PCB with columns for Symbol, Rating, and Remarks. Includes components R200, R201, R202, etc.

Capacitor

Table of Capacitor components for HIC PCB with columns for Symbol, Rating, and Remarks. Includes components C191, C201, C202, etc.

Diode

Table of Diode components for HIC PCB with columns for Symbol, Type, and Remarks. Includes components D201, D202, D203, etc.

IC

Table of IC components for HIC PCB with columns for Symbol, Type, and Remarks. Includes components IC2, IC3, IC5, etc.

Zener diode

Table of Zener diode components for HIC PCB with columns for Symbol, Type, and Remarks. Includes components CZ21, CZ22, CZ23, etc.

Transistor

Table of Transistor components for HIC PCB with columns for Symbol, Type, and Remarks. Includes components Q202, Q203, Q204, etc.

Inductor

Table of Inductor components for HIC PCB with columns for Symbol, Type, and Remarks. Includes component LB10.

Oscillator

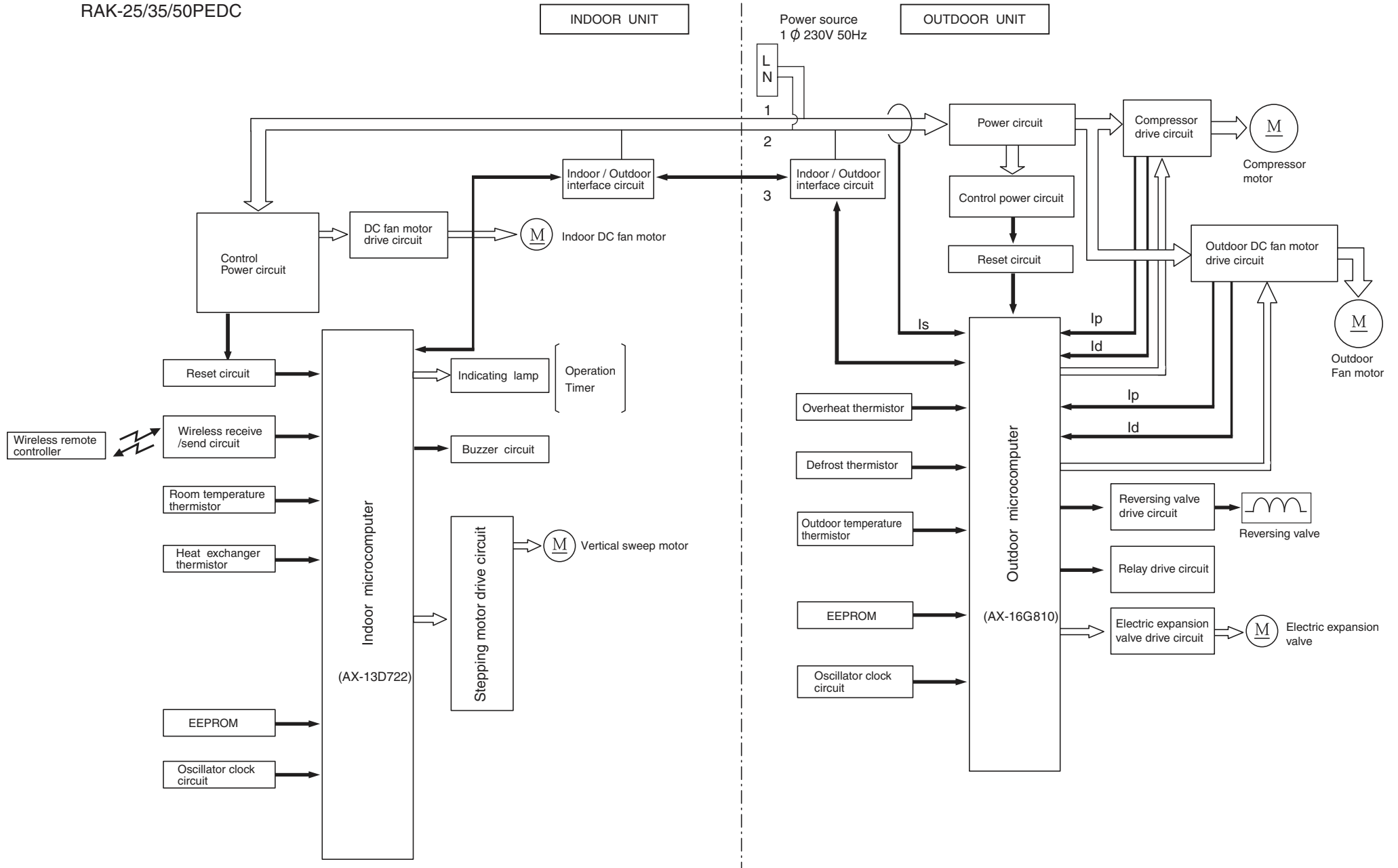
Table of Oscillator components for HIC PCB with columns for Symbol, Type, and Remarks. Includes component X1.

Jumper

Table of Jumper components for HIC PCB with columns for Symbol, Exist/No, and Remarks. Includes components JP1, JP2, JP3, etc.

**BLOCK DIAGRAM**

MODEL RAK-18/25/35/50PED  
 RAK-25/35/50PEDC



# BASIC MODE

MODEL RAK-18/25/35/50PED  
RAK-25/35/50PEDC

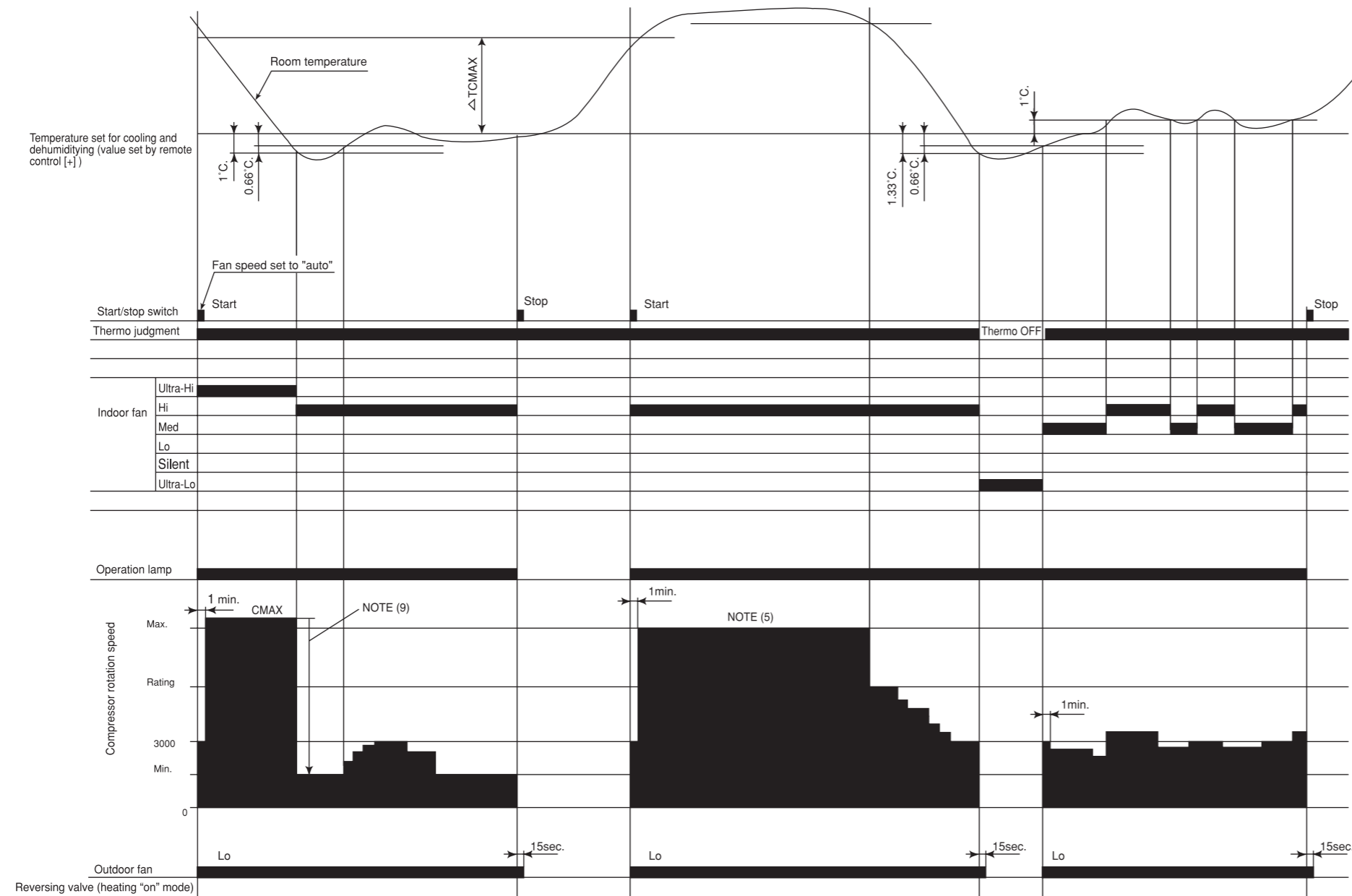
Operation mode		Cooling	Dehumidifying	Heating
Basic operation of start/stop button				
Timer functions	Off-timer			
	On-timer			
	Off -> On On -> Off timer			
Fan speed mode (indoor fan)	Auto	<p>Changes from "Hi" to "Med" or "Lo" depending on room temperature.</p> <ol style="list-style-type: none"> <li>Runs at "Hi" until room temperature reaches to "setting temperature-SFTDSC" after operation is started.</li> <li>Runs at "ultra-Lo" when thermo is off.</li> </ol>		<p>Set to "ultra-Lo", "Silent", "Lo", "Med", "Hi", "ultra-Hi" or "stop" depending on the room temperature, time and heat exchanger temperature. Set to "stop" if the heat exchanger temperature is "DNZKOF" during Thermo OFF.(When reach at "DNZKON", fan speed set to "ultra-Lo" again.)</p> <p>When the compressor is running at maximum speed during hot-dash or when recovered from defrosting.</p>
	Hi	Set to "ultra-Hi" when the compressor runs at cold dash mode speed, and to "Hi" in other modes. Runs at "ultra-Lo" when thermo is off. (Only for Caribbean area: Runs at "Hi" when thermo is off.)		Set to "ultra-Lo", "Silent", "Lo", "Med", "Hi", "ultra-Hi" or "stop" depending on the room temperature, time and heat exchanger temperature. Set to "stop" if the heat exchanger temperature is "DNZKOF" during Thermo OFF.(When reach at "DNZKON", fan speed set to "ultra-Lo" again.)
	Med	Operates at "Med" regardless of the room temperature. Runs at "ultra-Lo" when thermo is off. (Only for Caribbean area: Runs at "Med" when thermo is off.)		Set to "ultra-Lo", "Silent", "Lo", "Med", "Hi", "ultra-Hi" or "stop" depending on the room temperature, time and heat exchanger temperature. Set to "stop" if the heat exchanger temperature is "DNZKOF" during Thermo OFF.(When reach at "DNZKON", fan speed set to "ultra-Lo" again.)
	Lo	Operates at "Lo" regardless of the room temperature. Runs at "ultra-Lo" when thermo is off. (Only for Caribbean area: Runs at "Lo" when thermo is off.)	Set to "Lo" in modes other than when the compressor stops.	Set to "ultra-Lo", "Silent", "Lo", "Med", "Hi", "ultra-Hi" or "stop" depending on the room temperature, time and heat exchanger temperature. Set to "stop" if the heat exchanger temperature is "DNZKOF" during Thermo OFF.(When reach at "DNZKON", fan speed set to "ultra-Lo" again.) The fan speed is controlled by the heat exchanger temperature; the overload control is executed as in the following diagram:
	Silent	Operates at "Silent" regardless of the room temperature. Runs at "ultra-Lo" when thermo is off. (Only for Caribbean area: Runs at "Silent" when thermo is off.)	Set to "Silent" in modes other than when the compressor stops.	
Basic operation of temperature controller		See page 32.	See page 35.	See page 37.

Table 1 Mode data file

MODEL	RAK-18PED	RAK-25PED RAK-25PEDC	RAK-35PED RAK-35PEDC	RAK-50PED RAK-50PEDC
LABEL NAME	VALUE			
WMAX	4200 min <sup>-1</sup>	5800 min <sup>-1</sup>	6250 min <sup>-1</sup>	5700 min <sup>-1</sup>
WMAX2	4200 min <sup>-1</sup>	5800 min <sup>-1</sup>	6250 min <sup>-1</sup>	5700 min <sup>-1</sup>
WSTD	3100 min <sup>-1</sup>	4550 min <sup>-1</sup>	5200 min <sup>-1</sup>	4700 min <sup>-1</sup>
WJKMAX	2800 min <sup>-1</sup>	4200 min <sup>-1</sup>	5000 min <sup>-1</sup>	4200 min <sup>-1</sup>
WBEMAX	2800 min <sup>-1</sup>	3800 min <sup>-1</sup>	4550 min <sup>-1</sup>	3600 min <sup>-1</sup>
WSZMAX	2800 min <sup>-1</sup>	3500 min <sup>-1</sup>	3500 min <sup>-1</sup>	3000 min <sup>-1</sup>
CMAX	4300 min <sup>-1</sup>	4600 min <sup>-1</sup>	5850 min <sup>-1</sup>	5500 min <sup>-1</sup>
CMAX2	4300 min <sup>-1</sup>	4600 min <sup>-1</sup>	5850 min <sup>-1</sup>	5500 min <sup>-1</sup>
CSTD	3200 min <sup>-1</sup>	3200 min <sup>-1</sup>	4500 min <sup>-1</sup>	4500 min <sup>-1</sup>
CJKMAX	3000 min <sup>-1</sup>	3000 min <sup>-1</sup>	4300 min <sup>-1</sup>	3900 min <sup>-1</sup>
CBEMAX	2800 min <sup>-1</sup>	2800 min <sup>-1</sup>	3700 min <sup>-1</sup>	2800 min <sup>-1</sup>
CSZMAX	2200 min <sup>-1</sup>	2200 min <sup>-1</sup>	2900 min <sup>-1</sup>	2400 min <sup>-1</sup>
WIN-CMPH	2000 min <sup>-1</sup>	2000 min <sup>-1</sup>	2000 min <sup>-1</sup>	2300 min <sup>-1</sup>
WIN-CMPL	2000 min <sup>-1</sup>	2000 min <sup>-1</sup>	2000 min <sup>-1</sup>	2300 min <sup>-1</sup>
CMIN	1900 min <sup>-1</sup>	1900 min <sup>-1</sup>	2000 min <sup>-1</sup>	1800 min <sup>-1</sup>
STARTMC	90 Seconds	90 Seconds	90 Seconds	90 Seconds
DWNRATEW	80%	80%	80%	80%
DWNRATEC	60%	60%	60%	70%
SHIFTW	0.00 °C	0.00 °C	0.00 °C	0.00 °C
SHIFTC	0.00 °C	0.00 °C	0.00 °C	0.00 °C
CLMXTTP	30.00 °C	30.00 °C	30.00 °C	30.00 °C
TEION	2.00 °C	2.00 °C	2.00 °C	2.00 °C
TEIOF	6.00 °C	6.00 °C	6.00 °C	9.00 °C
SFTDSW	1.00 °C	1.00 °C	0.66 °C	0.66 °C
DFTIM-OTPO	43 Minutes	43 Minutes	43 Minutes	43 Minutes
DFTIM-OTPS	43 Minutes	43 Minutes	43 Minutes	43 Minutes
DFTIM-OTPI0	43 Minutes	43 Minutes	43 Minutes	43 Minutes
FCAUT-L	0.66 °C	0.66 °C	0.66 °C	0.66 °C
FCAUT-H	2.00 °C	2.00 °C	2.00 °C	2.00 °C
SFTDSC	0.66 °C	0.66 °C	0.66 °C	0.66 °C
OFTMPC	1.00 °C	1.00 °C	1.00 °C	1.00 °C
DASUPHH	43.00	45.00	45.00	39.00
DASDNHH	39.00	41.00	41.00	36.00
DASUPH	38.00	40.00	40.00	35.00
DASDNH	33.33	35.33	35.33	32.00
DASUPL	33.00	35.00	35.00	31.00
DASDNL	28.00	28.00	28.00	29.00
DASUPS	28.00	28.00	28.00	28.00
DASDNS	27.00	27.00	27.00	26.00
NORUPH	45.00	45.00	45.00	45.00
NORDNH	36.00	40.00	40.00	38.00
NORUPL	36.00	37.00	37.00	37.00
NORDNL	33.00	33.00	33.00	33.66
NORUPS	33.00	33.00	33.00	33.00
NORDNS	30.00	30.00	30.00	30.00
PDCIN2	50.00	50.00	54.00	50.00
PDCOF2	45.00	45.00	48.00	48.00
DNZKON	15.00	15.00	15.00	15.00
DNZKOF	13.00	13.00	13.00	13.00
FNUPPW-C	30 min <sup>-1</sup>	30 min <sup>-1</sup>	30 min <sup>-1</sup>	30 min <sup>-1</sup>
DFMAX-STD	5500 min <sup>-1</sup>	5500 min <sup>-1</sup>	5500 min <sup>-1</sup>	5000 min <sup>-1</sup>
DFMAX-ATF	5500 min <sup>-1</sup>	5500 min <sup>-1</sup>	5500 min <sup>-1</sup>	4000 min <sup>-1</sup>

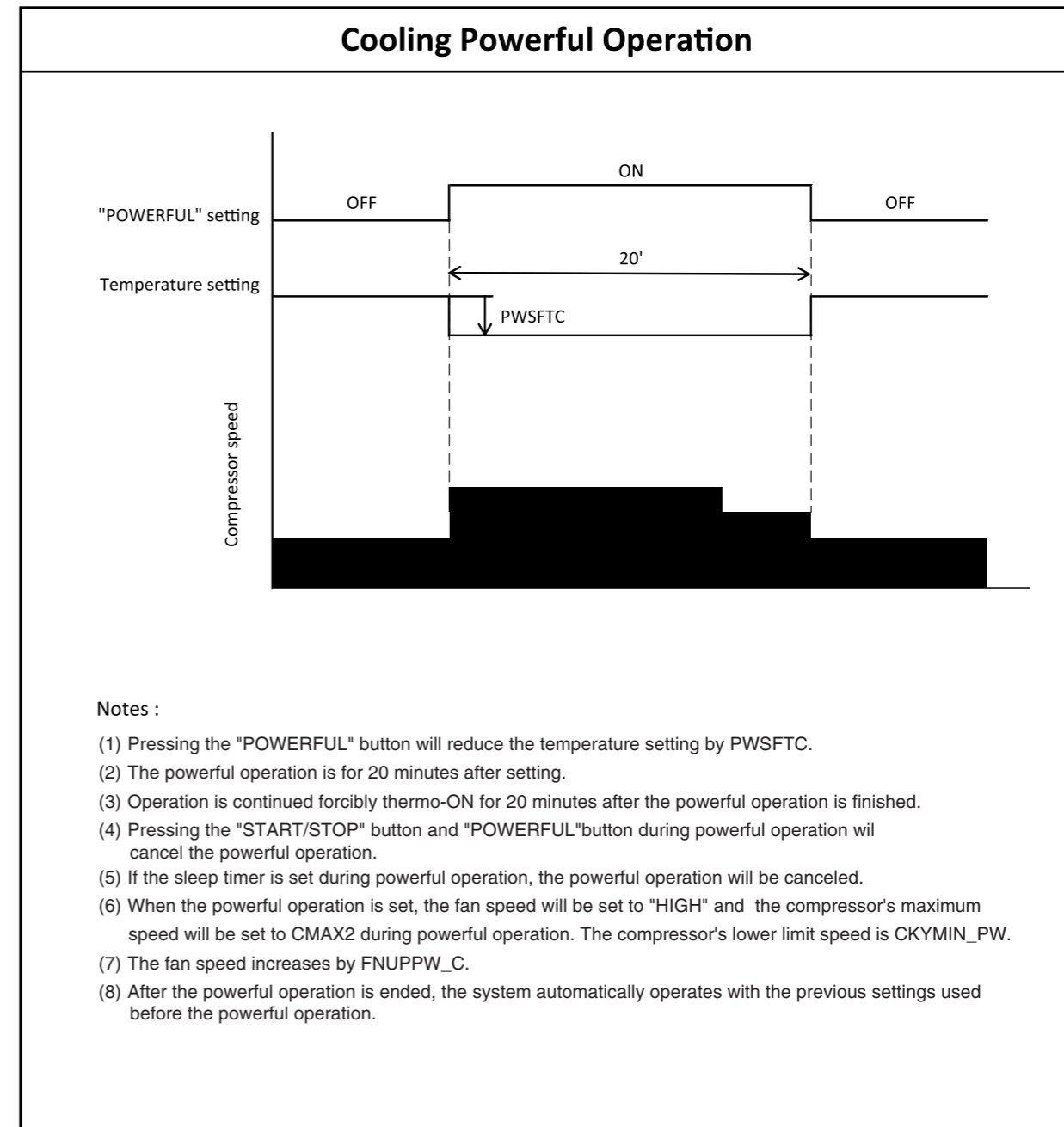
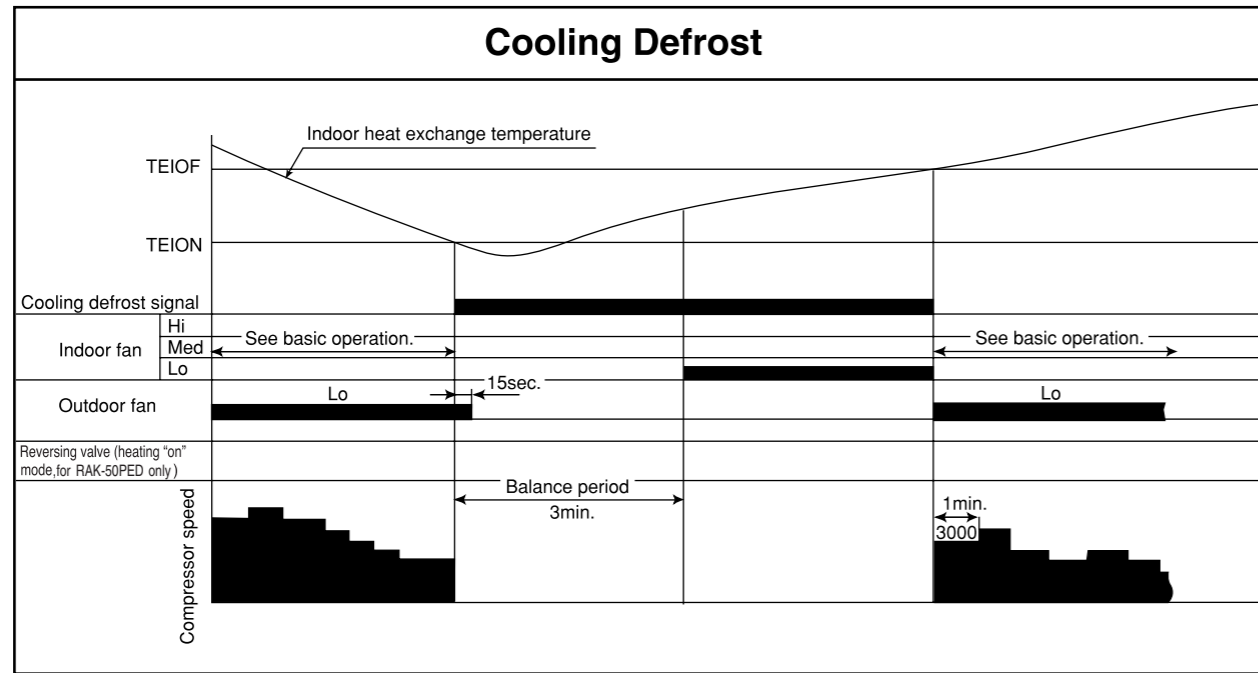


## Basic Cooling Operation



**Notes:**

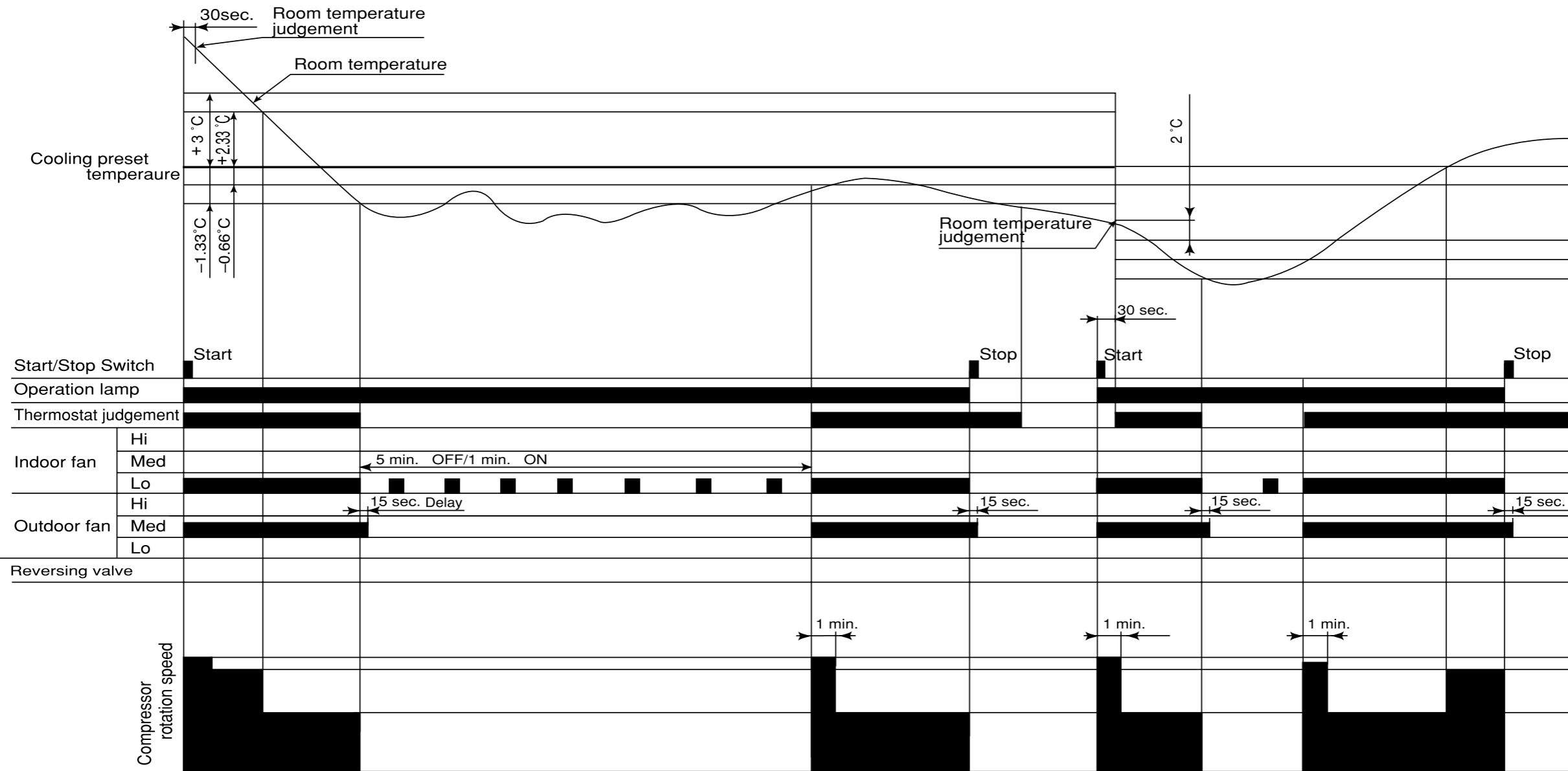
- (1) Condition for entering into Cool Dashed mode. When fan set to "Hi" or "Auto" and when the compressor speed (P section) due to temperature difference between setting temperature (including the correction shift only) and room temperature is C<sub>MAX</sub> or higher.
- (2) Cool Dashed will release when i) a maximum 25 minutes is lapsed and ii) room temperature is lower than set temperature  $-3^{\circ}\text{C}$  (thermo off) and iii) when room temperature has achieved setting temperature  $-1^{\circ}\text{C}$  then maximum Cool Dashed time will be revised to 20 minutes. And iv) indoor fan is set to Lo and Med fan mode and v) change operation mode.
- (3) During Cool Dashed operation, thermo off temperature is set temperature (with shift value)  $-3^{\circ}\text{C}$ . After thermo off, operation continue in Fuzzy control mode.
- (4) Compressor minimum "ON" time and "OFF" time is 3 minutes.
- (5) During normal cooling mode, compressor maximum rpm C<sub>MAX</sub> will maintain for 60 minutes if indoor temperature is lower than CLM<sub>XTP</sub>. No time constrain if indoor temperature is higher than CLM<sub>XTP</sub>.
- (6) When fan is set to "Hi", compressor rpm will be limited to C<sub>STD</sub>.
- (7) When fan is set to "Med", compressor rpm will be limited to C<sub>JKMAX</sub>.
- (8) When fan is set to "Lo", compressor rpm will be limited to C<sub>BEMAX</sub>.
- (9) During Cool Dashed, when room temperature reaches set temperature  $-1^{\circ}\text{C}$  compressor rpm is actual rpm x D<sub>WNRATEC</sub>.



**Notes :**

- (1) Pressing the "POWERFUL" button will reduce the temperature setting by PWSFTC.
- (2) The powerful operation is for 20 minutes after setting.
- (3) Operation is continued forcibly thermo-ON for 20 minutes after the powerful operation is finished.
- (4) Pressing the "START/STOP" button and "POWERFUL" button during powerful operation will cancel the powerful operation.
- (5) If the sleep timer is set during powerful operation, the powerful operation will be canceled.
- (6) When the powerful operation is set, the fan speed will be set to "HIGH" and the compressor's maximum speed will be set to CMAX2 during powerful operation. The compressor's lower limit speed is CKYMIN\_PW.
- (7) The fan speed increases by FNUPPW\_C.
- (8) After the powerful operation is ended, the system automatically operates with the previous settings used before the powerful operation.

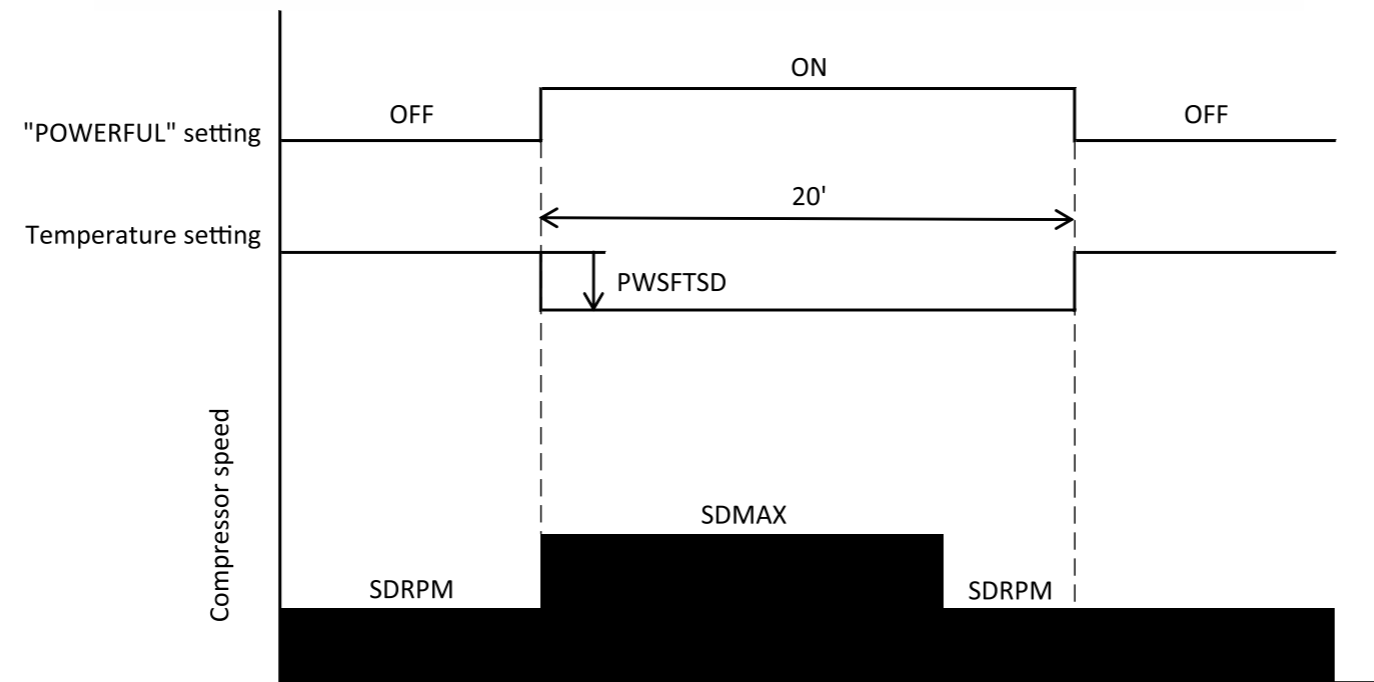
# Dehumidifying



**Notes:**

- (1) If the room temperature is (cooling preset temperature) - (1.33°C) or less after 30 seconds from starting the operation, the operation is done assuming as the preset temperature = (room temperature at the time) - (2°C).
- (2) The indoor fan is operated in the "Lo" mode. During thermo OFF indoor fan will be OFF for 5 minutes and ON for 1 minute.
- (3) When the operation is started by the thermostat turning ON, the start of the indoor fan is delayed 32 seconds after the start of compressor operation.
- (4) The compressor is operated forcedly for 3 minutes after operation is started.
- (5) The minimum ON time and OFF time of the compressor are 3 minutes.

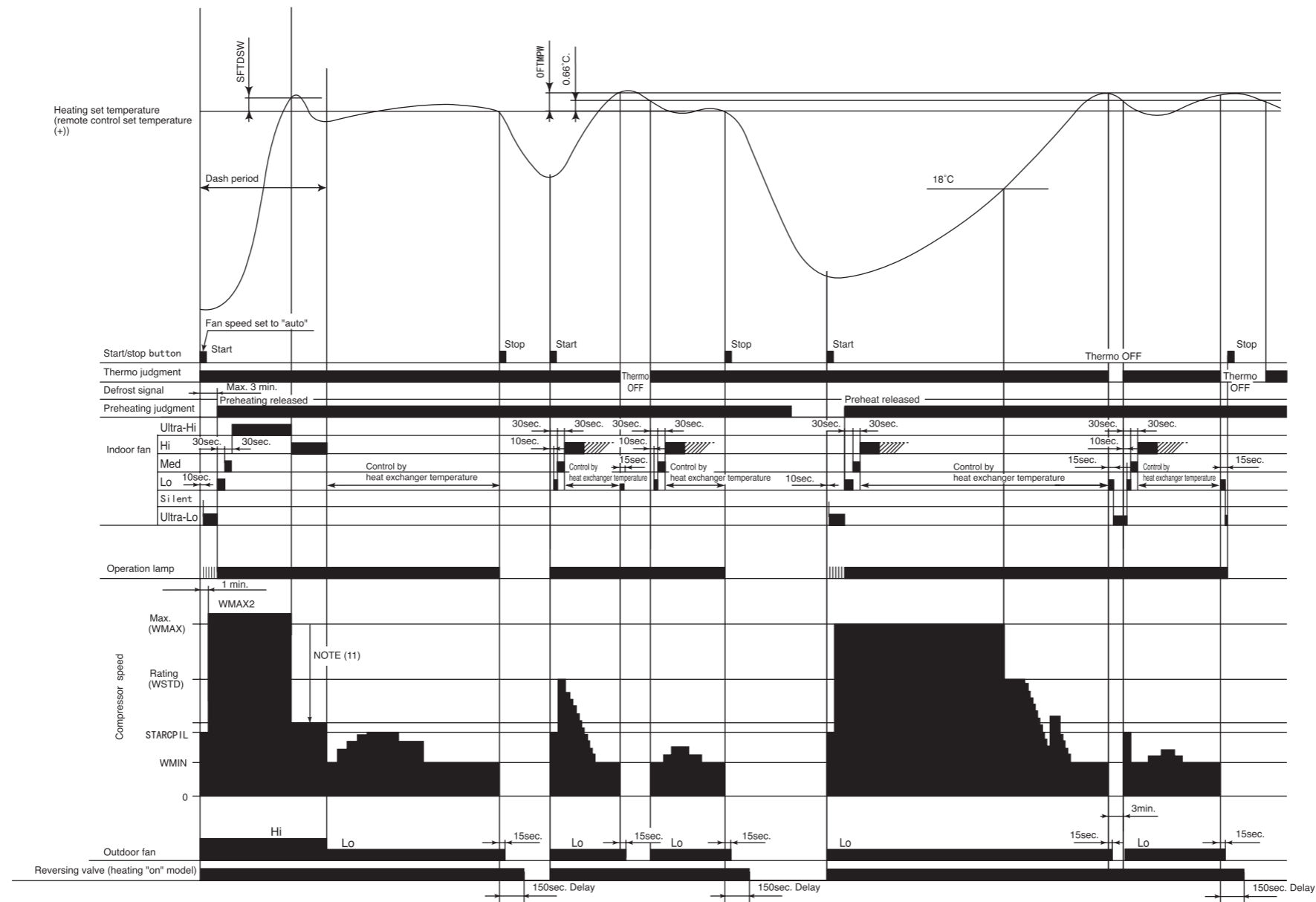
## Dehumidifying Powerful Operation



**Notes :**

- (1) Pressing the "POWERFUL" button will reduce the temperature setting by PWSFTSD.
- (2) The powerful operation is for 20 minutes after setting.
- (3) Operation is continued forcibly thermo-ON for 20 minutes after the powerful operation is finished.
- (4) Pressing the "START/STOP" button and "POWERFUL" button during powerful operation will cancel the powerful operation.
- (5) If the sleep timer is set during powerful operation, the powerful operation will be canceled.
- (6) If the differential (the room temperature - the temperature setting) is "the differential  $\geq 3$  °C" after powerful setting, the compressor's maximum speed during powerful operation will be set to SDMAX. Then the differential reduce "the differential  $\cong 2.33$  °C" during powerful operation, the compressor's speed will be set to SDRPM.  
If the differential (the room temperature - the temperature setting) is "the differential  $< 3$  °C" after powerful setting, the compressor's minimum speed during powerful operation will be set to SDRPM.
- (7) After the powerful operation is ended, the system automatically operates with the previous settings used before the powerful operation.

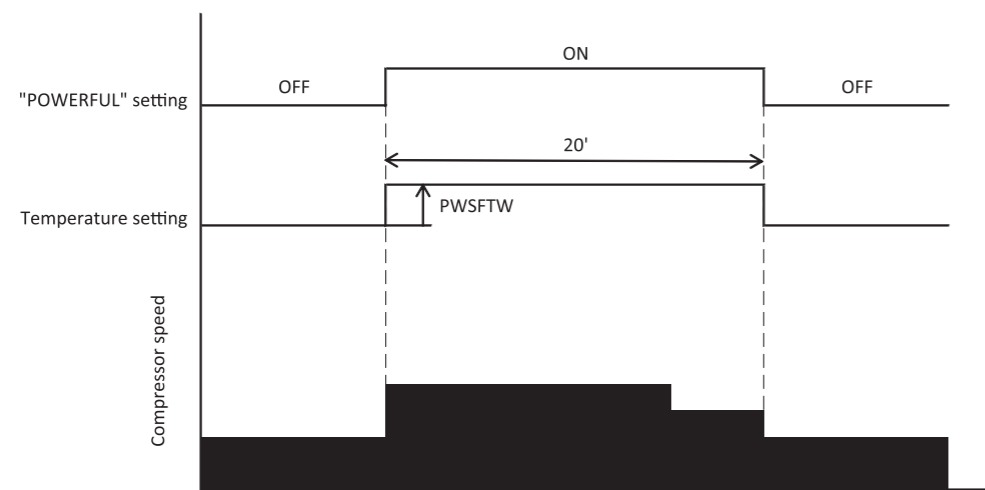
## Basic Heating Operation



### Notes:

- (1) Condition for entering into hot dashed mode. When fan set to "Hi" or "Auto" and i) room temperature is 18 or less, and ii) outdoor temperature is 10 or less, and iii) compressor speed (P section) due to temperature difference between setting temperature(including shift value only) and room temperature is WMAX or more.
- (2) The maximum compressor speed period during hot dash is finished when i) room temperature has reached the setting temperature + SFTDSW. ii) thermo off.
- (3) During hot dashed operation, thermo off temperature is setting temperature (with shift value) +3 . After thermo off, operation continue inn Fuzzy control mode.
- (4) Minimum "ON" time and minimum "OFF" time of compressor operation is 3 minutes.
- (5) During normal heating mode, compressor maximum rpm WMAX will maintain for 120 minutes. No time limit constrain if room temperature is 18 or less and outdoor temperature is 2 or less.
- (6) During preheating or defrosting or auto fresh defrosting mode, indoor unit operation lamp will blink at interval of 2 seconds "ON" and 1 second "OFF".
- (7) When heating mode starts, it will enter into preheating mode if indoor heat exchanger temperature is less than YNEOF + 0.33 .
- (8) When fan is set to "Med" or "Lo" or "Silent", compressor rpm will be limited to "WJKMAX" or "WBEMAX" or "WSZMAX".
- (9) During "Ultra-Lo" mode, if room temperature is 18 or less, indoor fan will stop. If room temperature is 18 + 0.33 or more, fan will continue in "Ultra-Lo" mode. However, "Ulirta-Lo" mode during preheating or preheating after defrosting does not stop if room temperature is 18 or less.
- (10) During hot dashed or outdoor temperature is -5 or less, compressor rpm is WMAX2.
- (11) During hot dashed, when room temperature reaches setting temperature + SFTDSW compressor rpm is actual rpm x DWNRATEW.

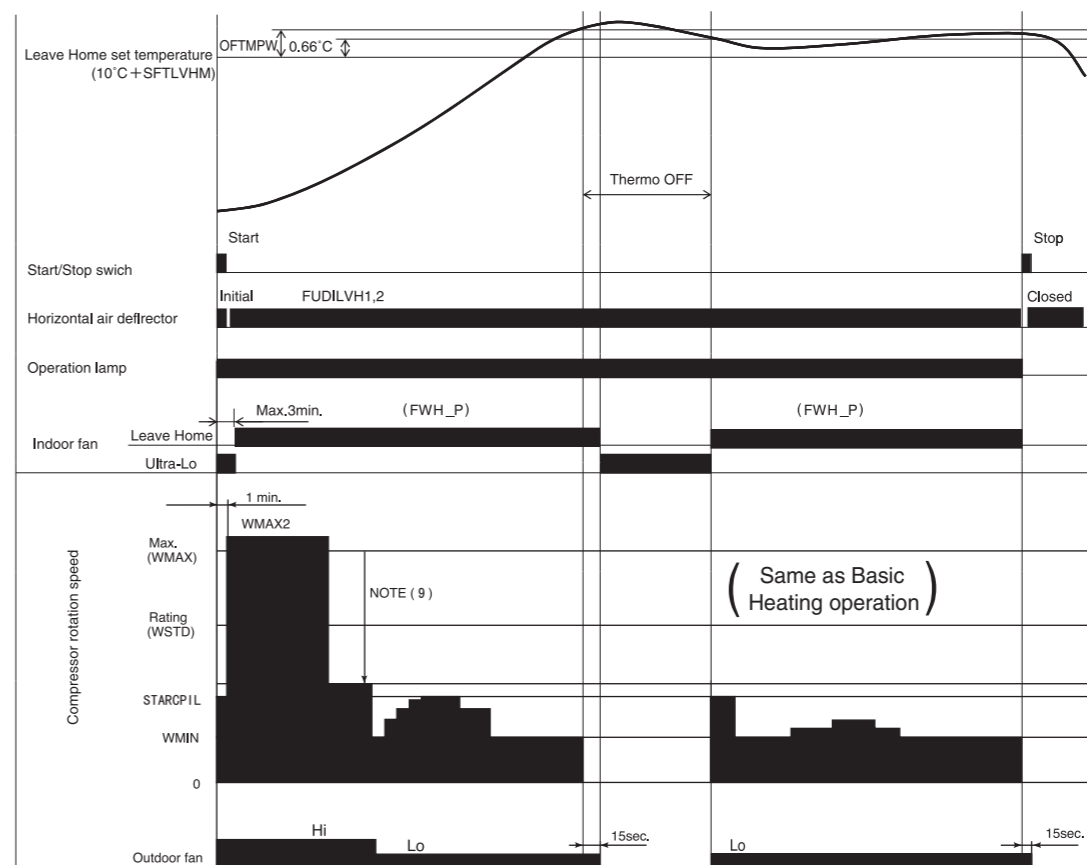
### Heating Powerful Operation



Notes :

- (1) Pressing the "POWERFUL" button will increase the temperature setting by PWSFTW.
- (2) The powerful operation is for 20 minutes after setting.
- (3) Operation is continued forcibly thermo-ON for 20 minutes after the powerful operation is finished.
- (4) Defrost is inhibited for 20 minutes after the start of the powerful operation.
- (5) Pressing the "START/STOP" button and "POWERFUL" button during powerful operation will cancel the powerful operation.
- (6) If the sleep timer is set during powerful operation, the powerful operation will be canceled.
- (7) When the powerful operation is set, the fan speed will be set to "HIGH" and the compressor's maximum speed will be set to WMAX2 during powerful operation. The compressor's lower limit speed is WKYMIN\_PW.
- (8) After the powerful operation is ended, the system automatically operates with the previous settings used before the powerful operation.

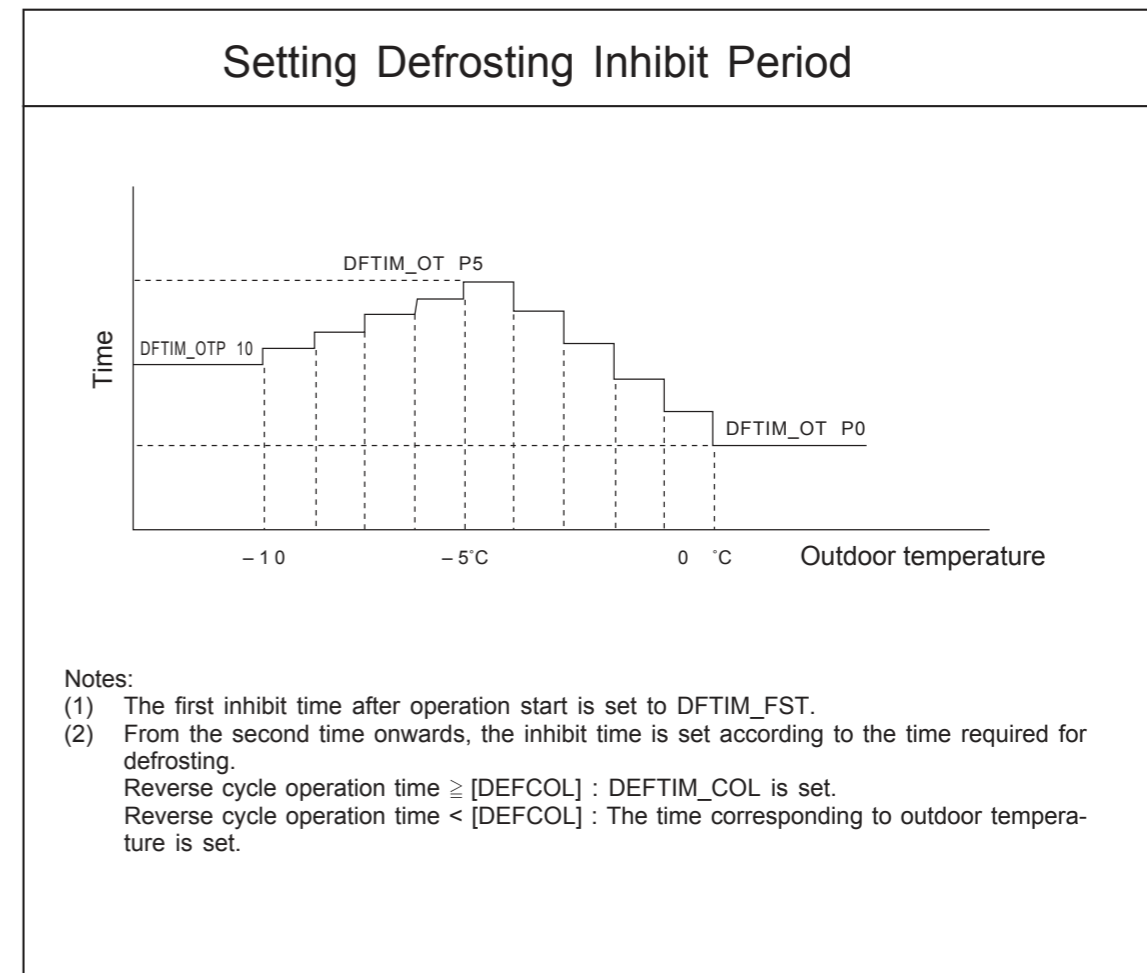
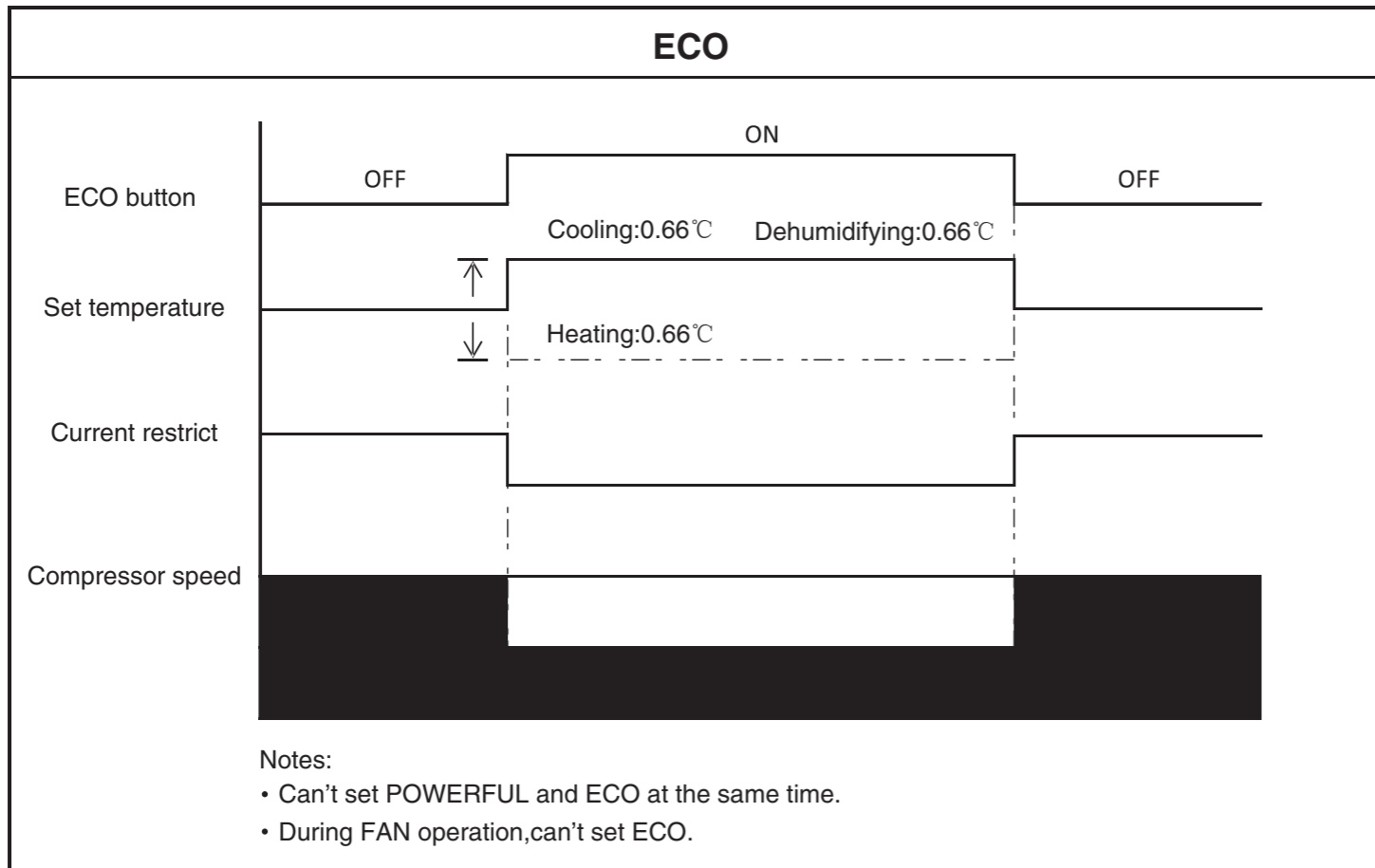
### Leave Home



Notes:

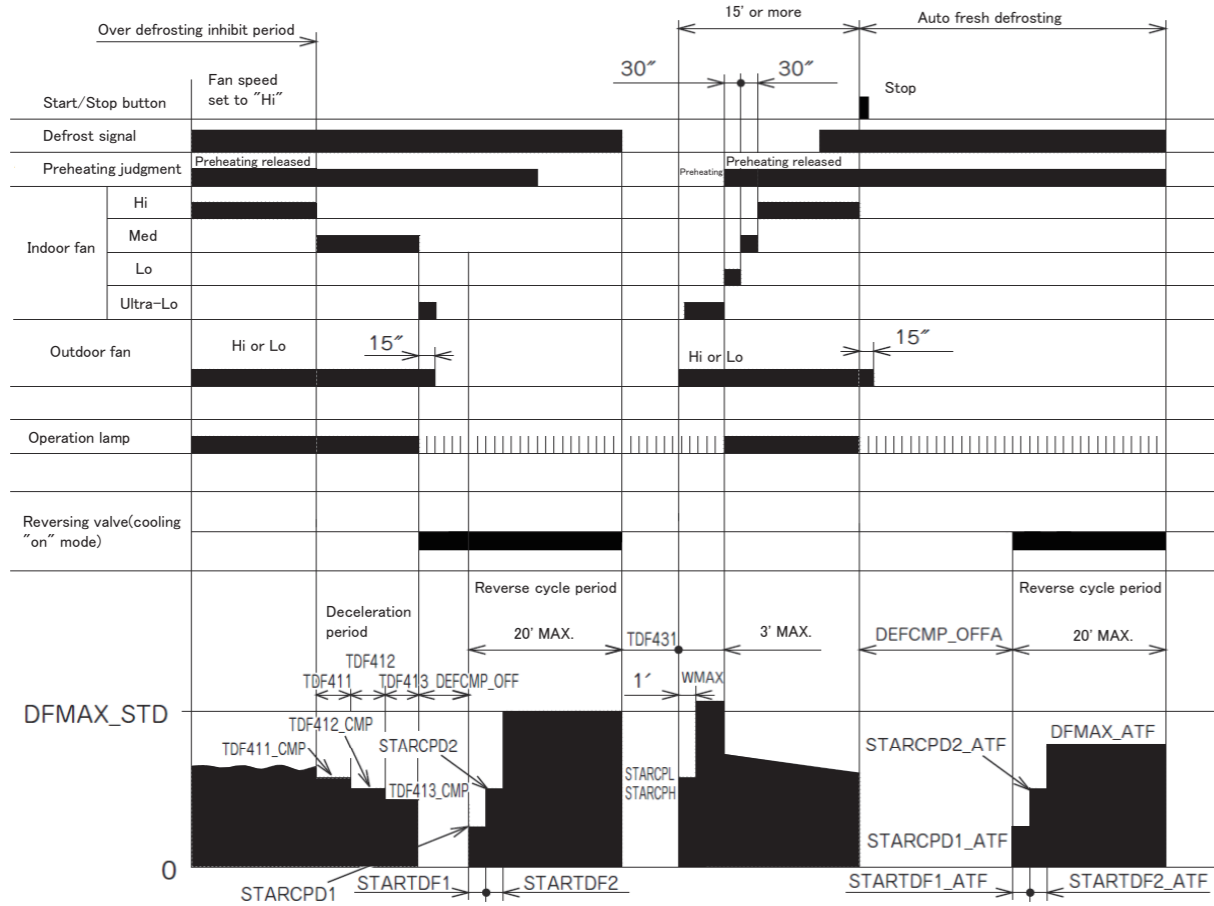
Perform Leave Home operation according to the following control contents.

- (1) Operation mode : Heating
- (2) Setting temperature : 10°C
- (3) Shift value : + SFTLVHM
- (4) Indoor fan speed : FWH\_P
- (5) Outdoor fan speed :
- (6) Compressor start control: } Same as Basic Heating operation
- (7) Compressor speed : }
- (8) Operation lamp : ON



**RAK-18/25/35PED  
RAK-25/35PEDC**

**Reversing valve defrosting**

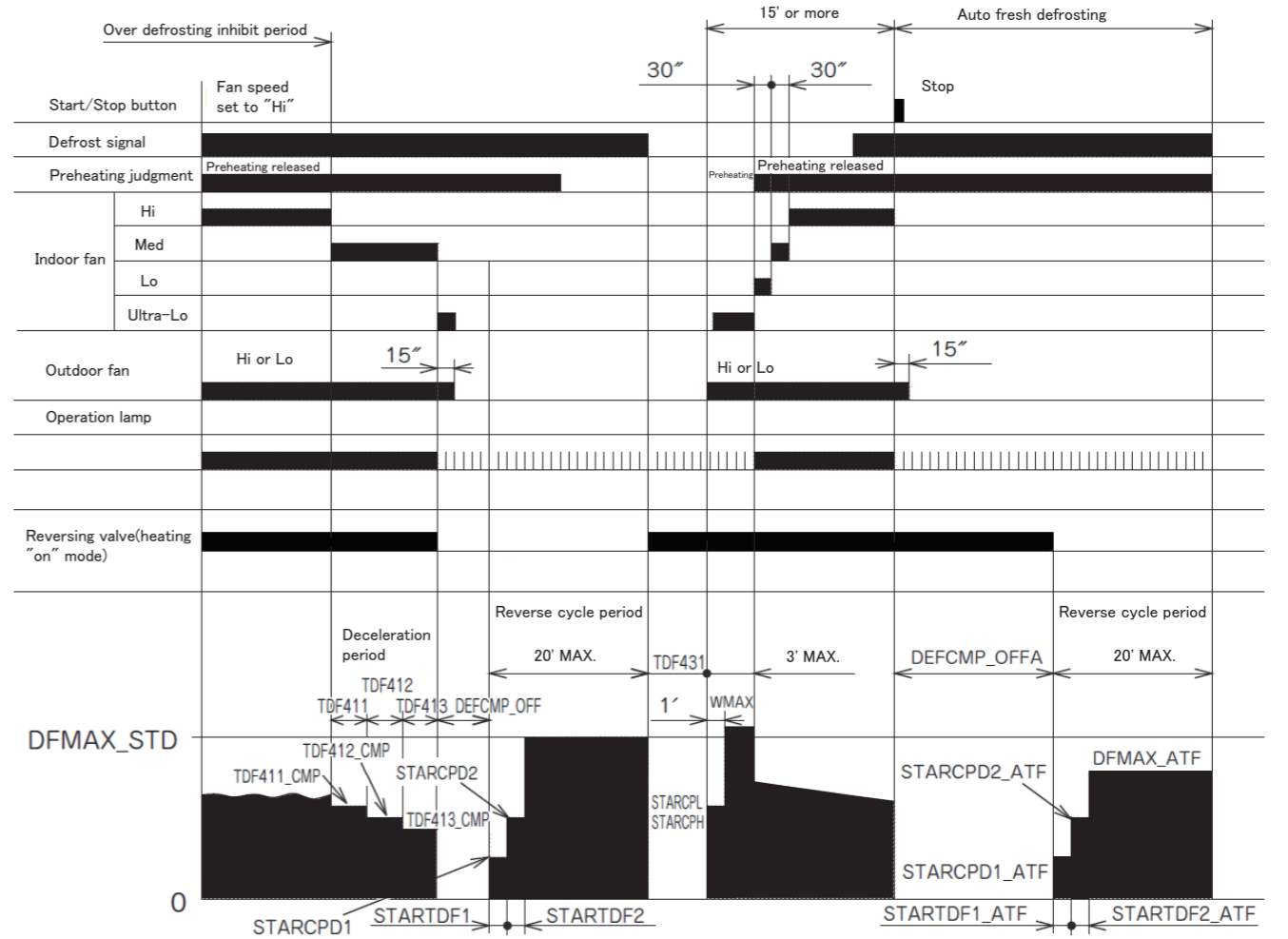


**Notes:**

- (1) The defrosting inhibit period is set as shown in the diagram below. When defrosting has finished once, the inhibit period is newly set, based on the outdoor temperature when the compressor was started. During this period, the defrost signal is not accepted.
- (2) If the difference between the room and outdoor temperature is large when defrosting is finished, the maximum compressor speed (WMAX) or (WMAX2) can be continued for 120 minutes maximum.
- (3) The defrosting period is 20 minutes maximum.
- (4) When operation is stopped during defrosting, it is switched to auto refresh defrosting.
- (5) Auto refresh defrosting cannot be engaged within 15 minutes after operation is started or defrosting is finished.

**RAK-50PED  
RAK-50PEDC**

**Reversing valve defrosting**



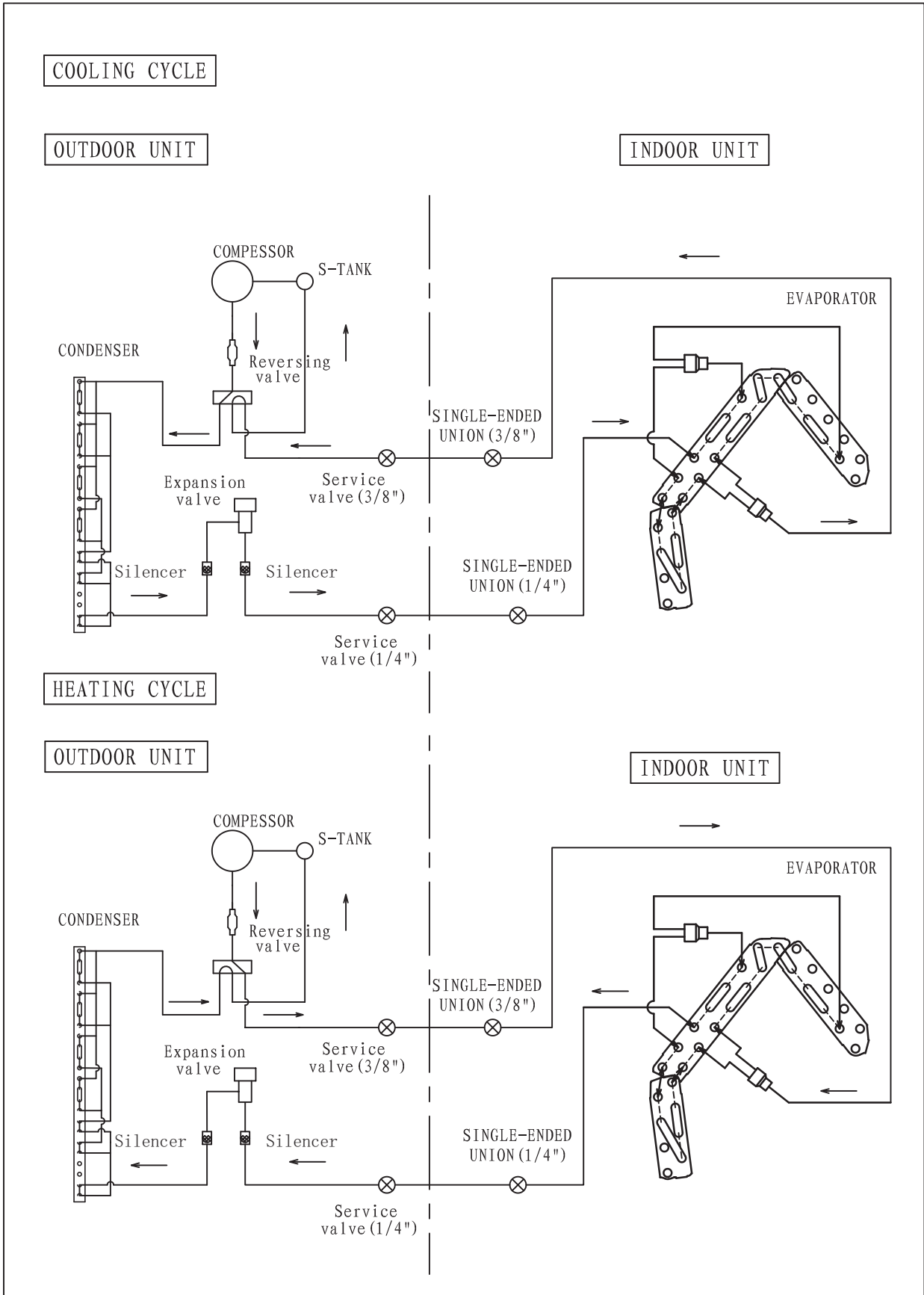
**Notes:**

- (1) The defrosting inhibit period is set as shown in the diagram below. When defrosting has finished once, the inhibit period is newly set, based on the outdoor temperature when the compressor was started. During this period, the defrost signal is not accepted.
- (2) If the difference between the room and outdoor temperature is large when defrosting is finished, the maximum compressor speed (WMAX) or (WMAX2) can be continued for 120 minutes maximum.
- (3) The defrosting period is 20 minutes maximum.
- (4) When operation is stopped during defrosting, it is switched to auto refresh defrosting.
- (5) Auto refresh defrosting cannot be engaged within 15 minutes after operation is started or defrosting is finished.



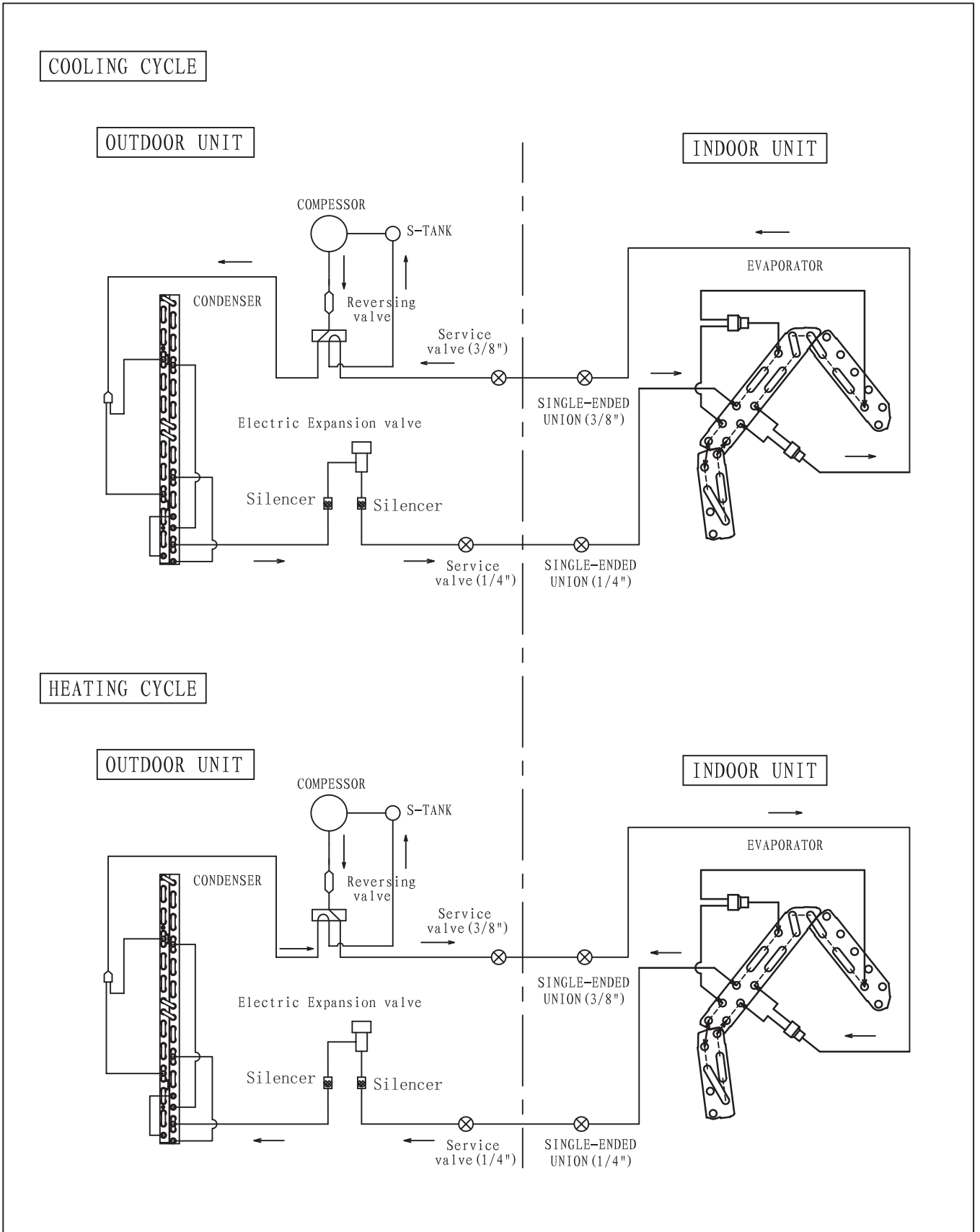
# REFRIGERATING CYCLE DIAGRAM

MODEL RAK-18/25PED, RAK-25PEDC  
 RAC-18/25WED



# REFRIGERATING CYCLE DIAGRAM

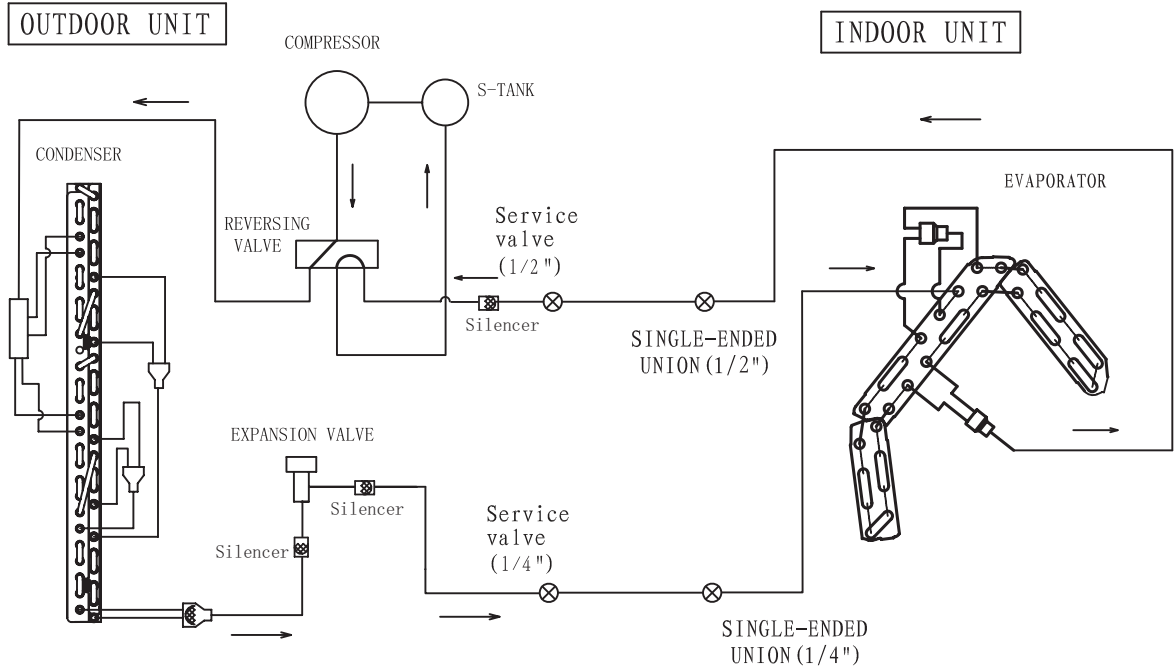
MODEL RAK-35PED, RAK-35PEDC  
RAC-35WED



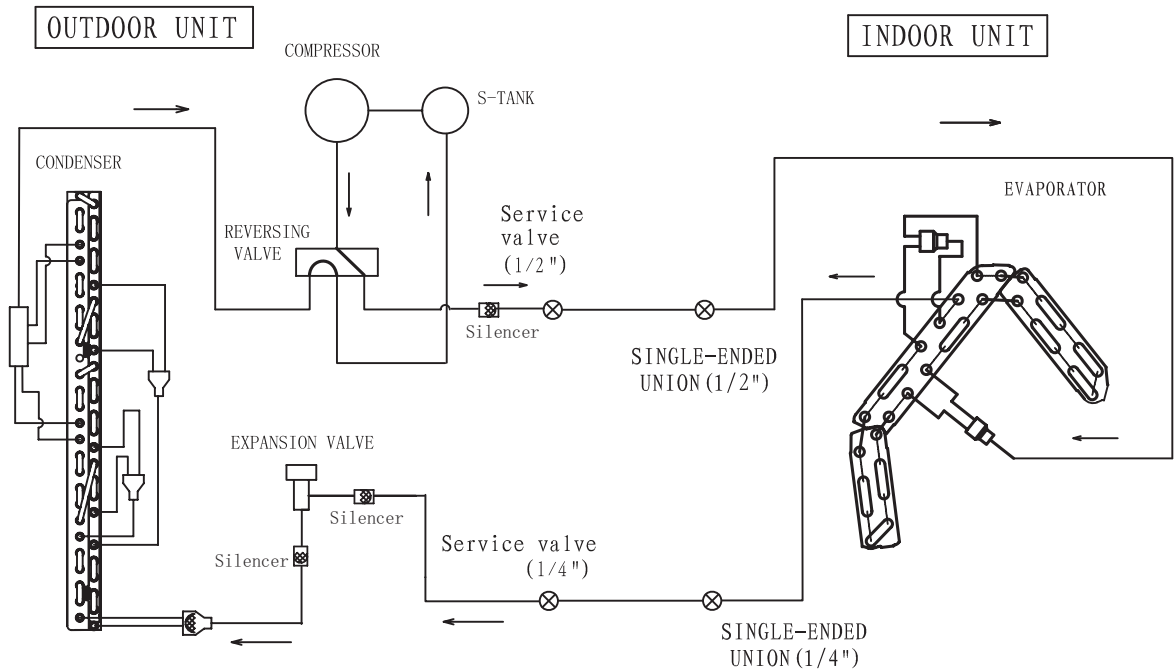
# REFRIGERATING CYCLE DIAGRAM

MODEL RAK-50PED, RAK-50PEDC  
RAC-50WED

## COOLING CYCLE



## HEATING CYCLE



# Procedure for Disassembly and Reassembly

INDOOR UNIT RAK-18/25/35/50PED  
RAK-25/35/50PEDC

## 1. Front Panel

Be sure to hold the front panel with both hands to detach and attach it.

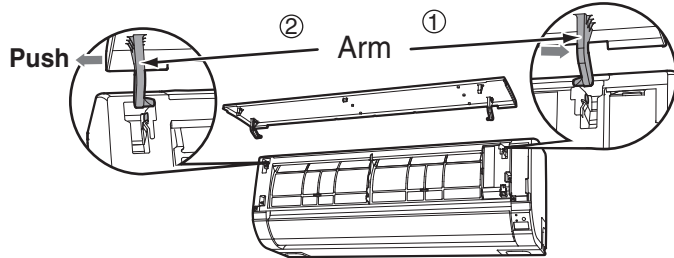


Fig. 1

1. Push the end of the right-side arm outward to release the tab.
2. Move the left-side arm outward to release the left tab, and then pull the panel towards you.

## 2. Front cover

- (1) After removing the screw of fixing the terminal cover, hold the handle of terminal cover and remove it.
- (2) After removing two screws, pull the center of the front cover forward and release the claws.
- (3) Hold the front cover at both lower sides and pull them forward to remove.

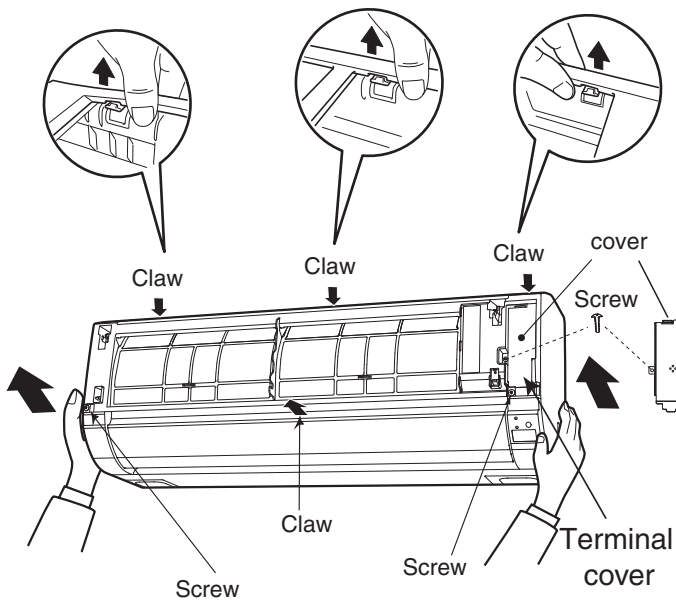


Fig. 2

## 3. Control P.W.B. and Indicating P.W.B.

- (1) Remove each connector from the lead wire.
- (2) Remove the four P.W.B. supports from the control P.W.B.

- (3) Pull the support hook at the upper side of the indication lamp of the indicating P.W.B. and pull out the P.W.B. forward.

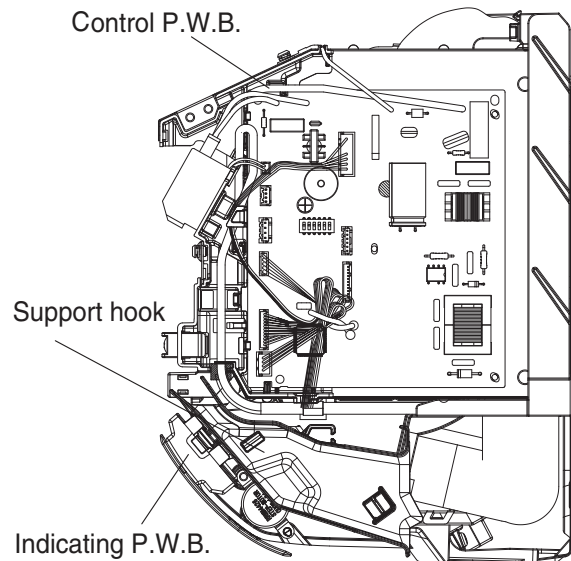


Fig. 3

## 4. Tangential air flow fan and fan motor

- (1) Loosen the fan lock screw.

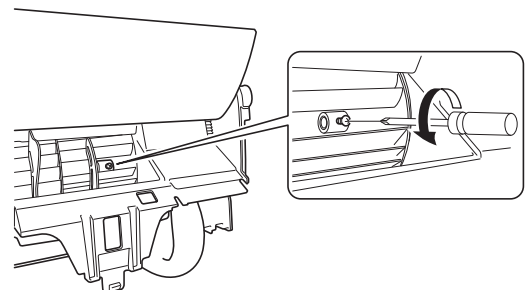


Fig. 4

- (2) Press the fan motor cover 2 fixed pawl, and remove from the right to.

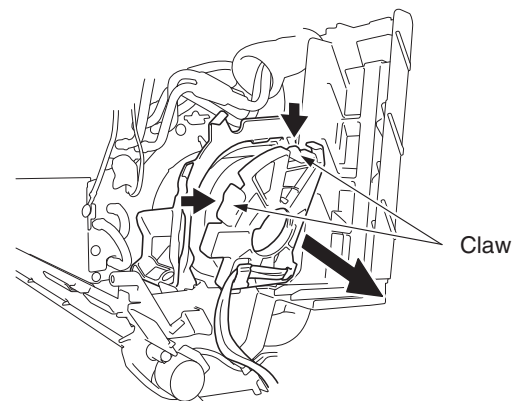


Fig. 5

(3) Pull fan motor out of the remove the right.

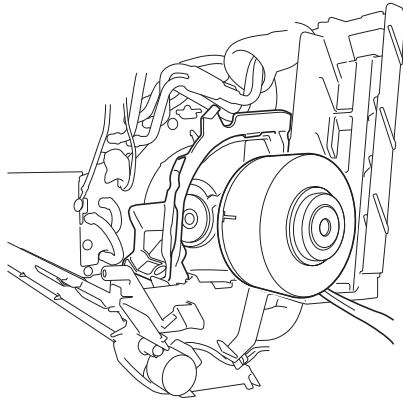


Fig. 6

(4) Remove the screws from the upper and lower bearing covers.

(5) Remove the locking hook of the lower bearing cover from the Cabinet.

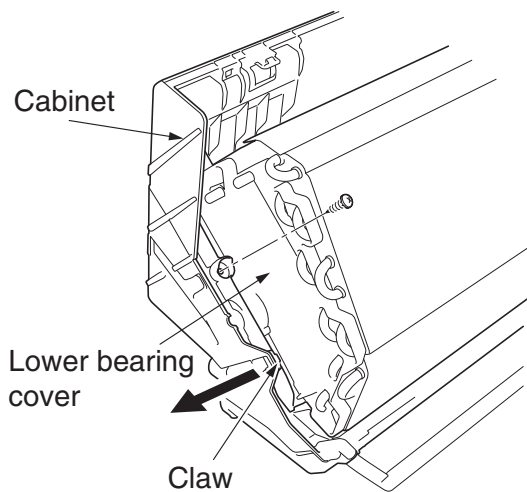


Fig. 7

(6) Remove the fan and bearing from the left.

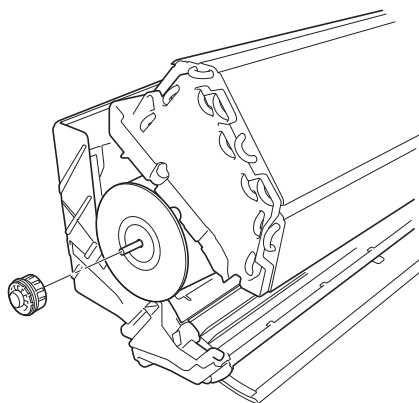


Fig. 8

**Points for attention of fan motor and tangential air flow fan installation.**

When installing the flow fan, the first part of the fan and water seal plate on the tube plate overlap, then tighten the screw.

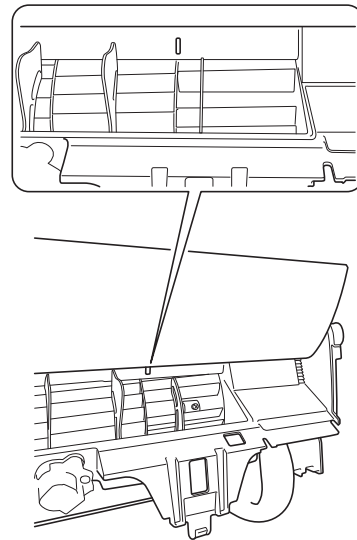


Fig. 9

**5. Stepping motor**

(1) The FC-guide frame fixed claw right side press. Remove the FC-guide from the rear.

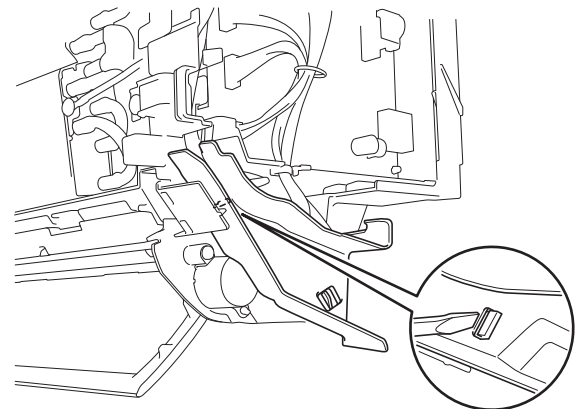


Fig. 10

(2) Remove the stepping motor screws and take off the stepping motor.

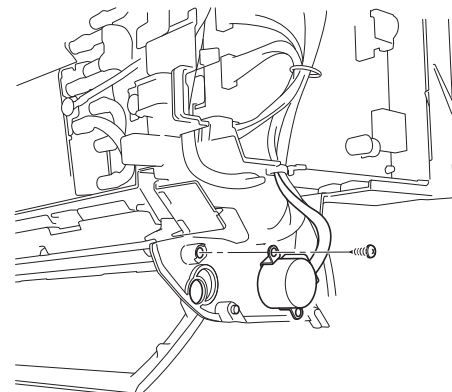


Fig. 11

**<OUTDOOR UNIT>**

**MODEL RAC-18/25/35WED**

**1. Electrical Parts**

- (1) Remove the upper cover fixing screws and lift the cover to remove it.
- (2) Remove the service valve cover.
- (3) Remove the terminal plate cover.
- (4) Remove the right side cover.

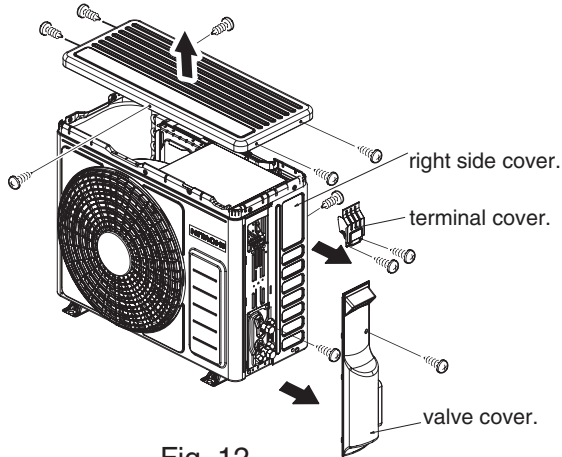


Fig. 12

- (5) Remove the electrical box fixing screws and GND wire fixing screw.

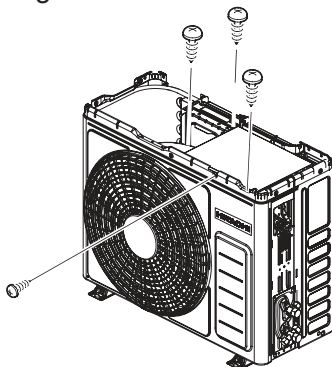


Fig. 13

- (6) Remove P lock which binds lead wires.
- (7) Set the electrical box upside down.

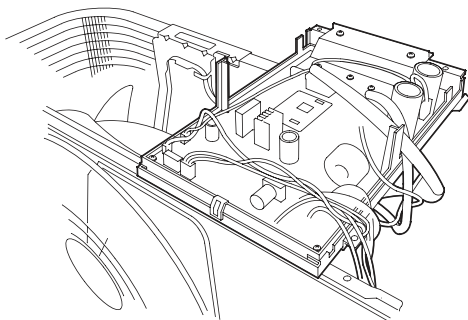


Fig. 14

- (8) Remove P.W.B. fixing screws (2 locations) and radiation fin fixing screws (7 locations), and remove the P.W.B. from the support.

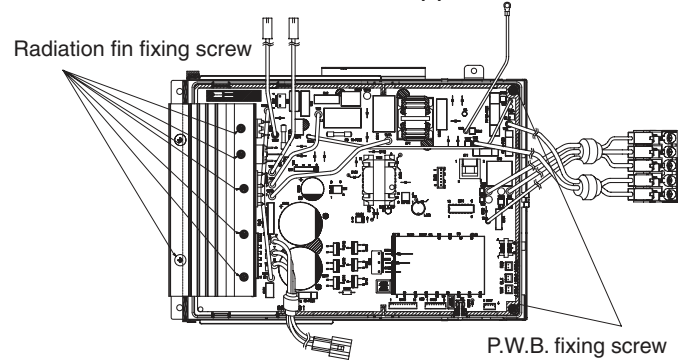


Fig. 15

**OUTDOOR UNIT MODEL RAC-50WED**

**1. Electrical parts**

- (1) Remove the service valve cover lock screws and lower the cover to remove it.
- (2) Remove the top cover lock screw and raise the cover to remove it.

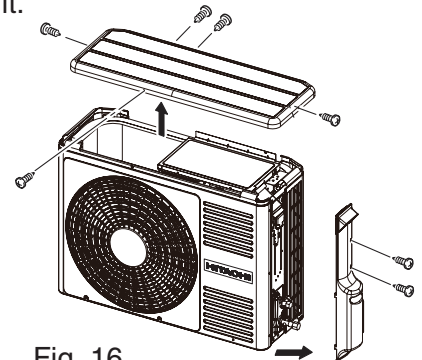


Fig. 16

- (3) Remove the front cover lock screw.
- (4) Lower the right side of the front cover and pull it forward. Then, remove the cover from the hook.
- (5) Pull the right side of the front cover a little and pull up the left side to remove it from the hook.

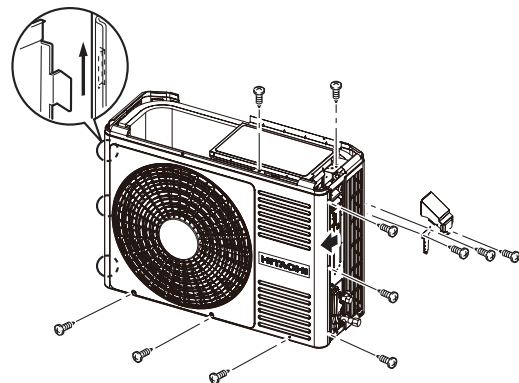


Fig. 17

- (6) Remove each connector and earth cable from the lead wire. Then, remove the electrical box.

# DESCRIPTION OF MAIN CIRCUIT OPERATION

MODEL RAK-18/25/35/50PED

RAK-25/35/50PEDC

## 1. Control power circuit

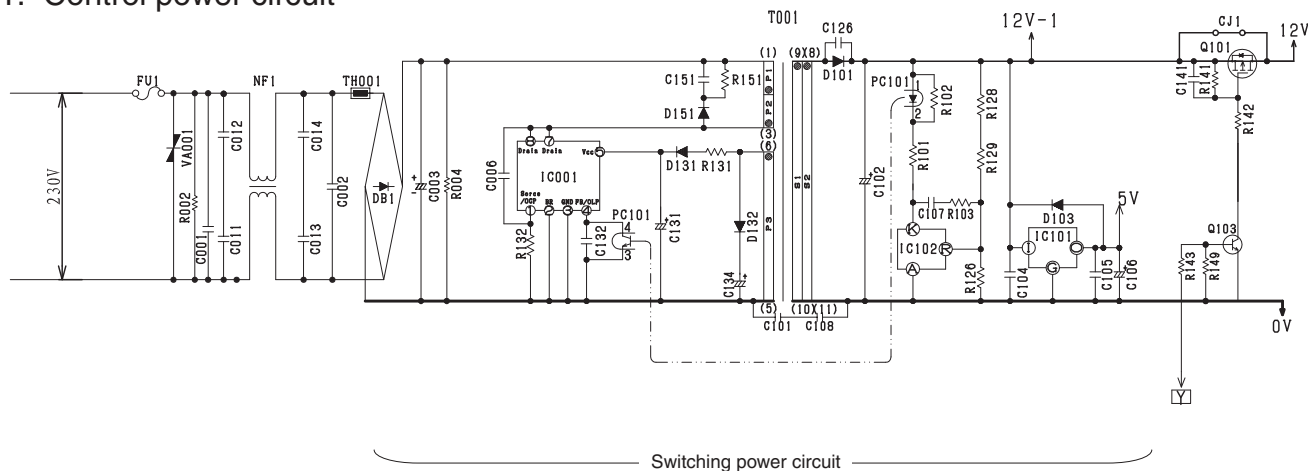


Fig. 1-1

- An AC power supply from outdoor unit passes through the 3.15 A fuse, varistor (VA001), and noise filter circuit and rectified and smoothed by DB1 and C003 to become a DC current 325 V. It is then supplied to indoor fan motor drive circuit, and switching power circuit.
- The switching power circuit, as controlled by IC001, drives the primary winding of the transformer (T001) to produce a specified voltage at the output winding. [The output terminal (pin ⑦⑧) of IC001 has a switching voltage. But it changes in voltage peak and oscillation period depending on the power load. usually, the oscillation frequency when the air condition operation is about 67 kHz. In the standby state, the oscillation frequency is lowered to a level as low as 20 kHz or so to reduce the standby power.]
- The outputs of the output windings of the transformer is rectified and smoothed to become DC voltages at primary 18.5 V, and 12 V respectively. The primary 18.5 V is supplied to the drive circuit of the indoor fan motor, the 12 V is supplied to each vane motor and to the drive circuits of the cleaning unit driving motor and other equipment, the 12 V is adjusted to a stable 5 V by the 3-terminal regulator IC (IC101) and supplied to the microcomputer peripheral circuit.

### Check

If a failure in a part or circuit has produced an abnormal current in the power supply, the 3.15 A fuse will melt down to prevent further damage. If the 3.15 A fuse melts down, check the indoor fan motor, switching electrical circuit, and other components and replace any defective part.

### Check

If an abnormally high voltage is applied to the power supply, the 3.15 A fuse and varistor (VA001) will prevent further damage. If a high voltage results in the 3.15 A fuse melted down, the varistor (VA001) should have deteriorated and destroyed. Therefore replace it at the same time.

### Caution

The primary circuit of the transformer (T001) has a voltage to ground. Guard against electric shocks.

## 2. Reset Circuit

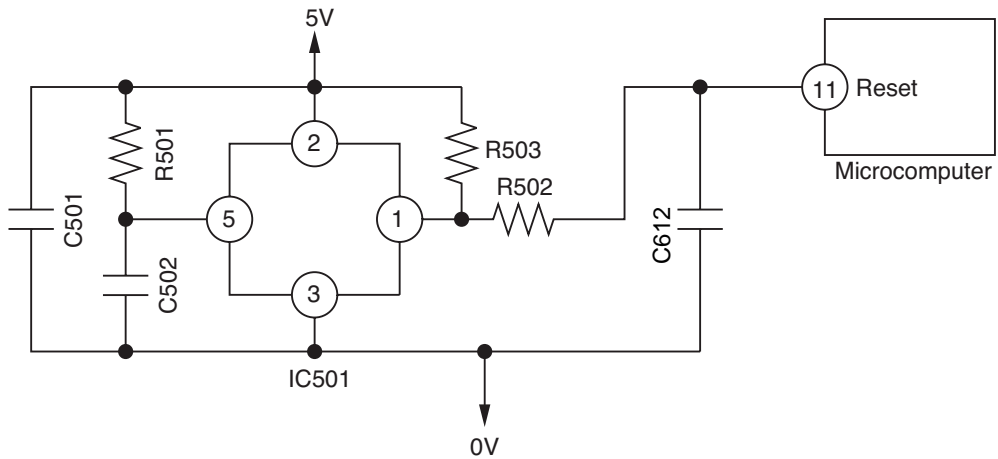


Fig.2-1

### Timing chart

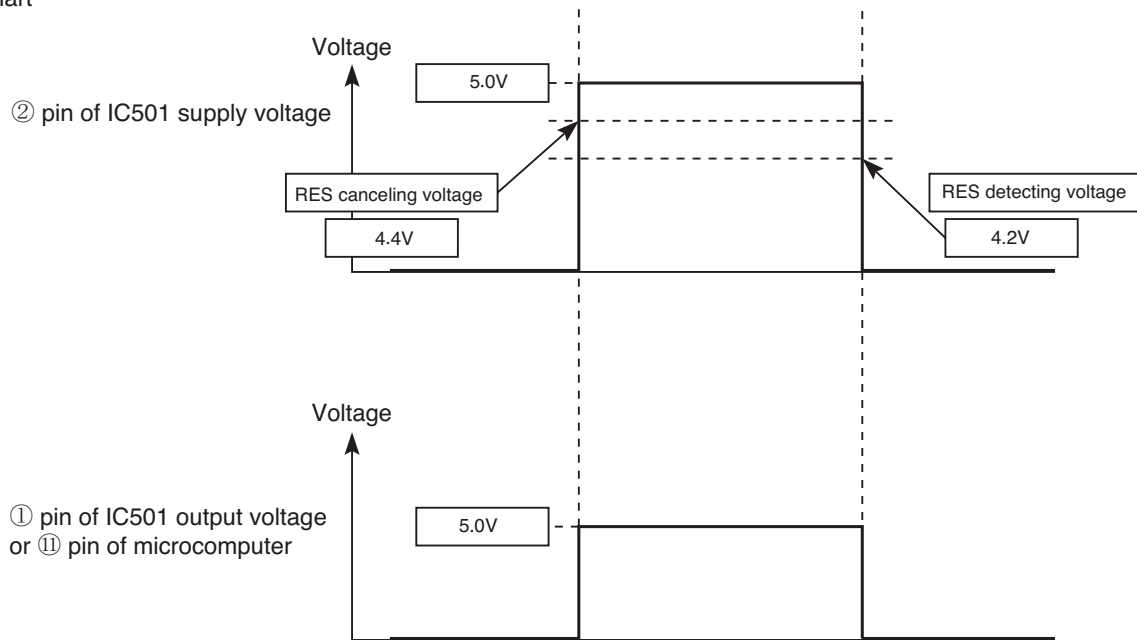


Fig.2-2

- Reset circuit is to initialize the indoor unit microcomputer when switching ON the power or after recovering from power failure.
- Microcomputer operates when ⑪ pin of the indoor unit microcomputer (reset input) is "Lo" for resetting and "Hi" for heating.
- Waveform of each part when switching ON the power and when shutting down is shown in the Fig. 2-2.
- After switching ON the power, ① pin of IC501 supply voltage and ⑪ pin of microcomputer becomes Hi when DC5V line rises and reaches approximately 4.4V or higher. Then, resetting will be cancelled and microcomputer starts operating.
- After shutting down the power, ① pin of IC501 supply voltage and ⑪ pin of microcomputer becomes Lo when DC5V line falls and reaches approximately 4.2V or lower. Then, the microcomputer will be in reset condition.



### 3. Drive circuit of the indoor fan motor

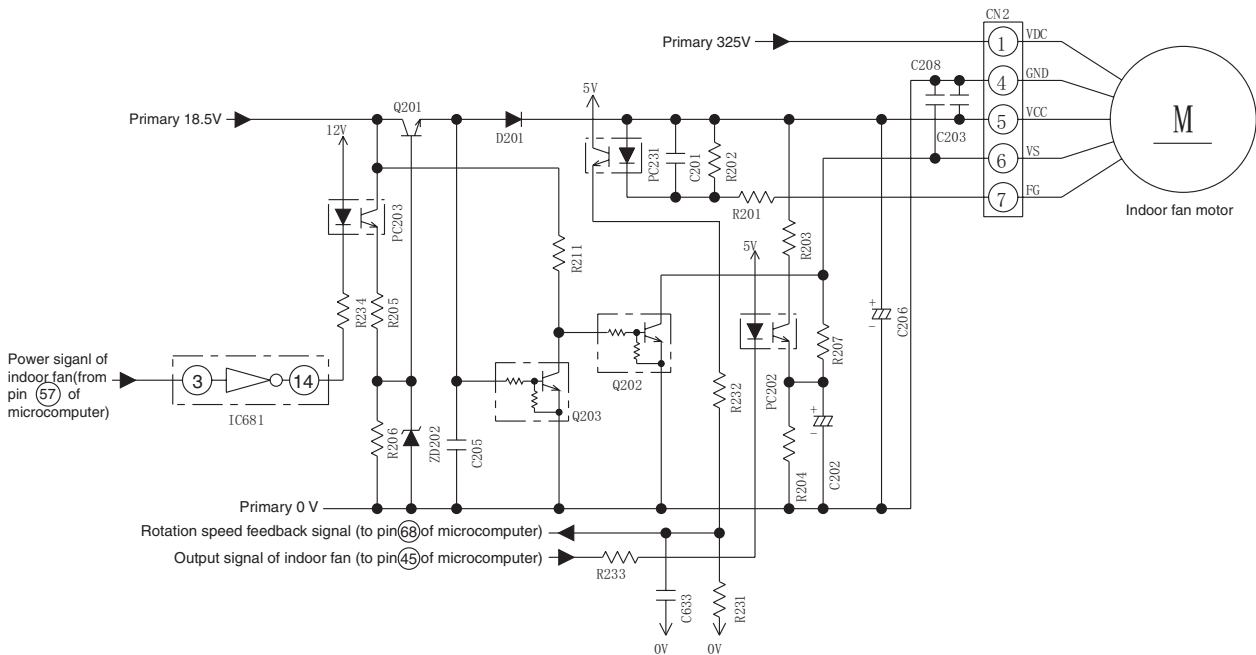
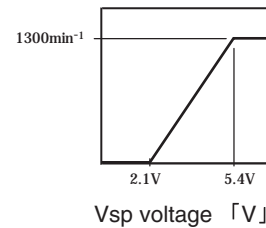


Fig. 3-1

< The circuit check (For test) >

Name	Test point	Test voltage
Motor drive power	CN2 ① pin- ④ pin	About 325V
Motor control power	CN2 ⑤ pin- ④ pin	About 15V
Motor speed signal	CN2 ⑥ pin- ④ pin	About 2-6V
Motor rotation speed debug	CN2 ⑦ pin- ④ pin	About 7.5V

< Pin 6 - Pin 4 voltage one example >



- \* The voltage above is all motor operation vol. when you start the test, take care of your connector, do not touch the different pin together.
- \* The voltage of pin ⑥ - pin ④ , pin ⑦ - ④ maybe different from above.

\* The different mode maybe have different FAN rotation speed.

< Typical circuit waveform >

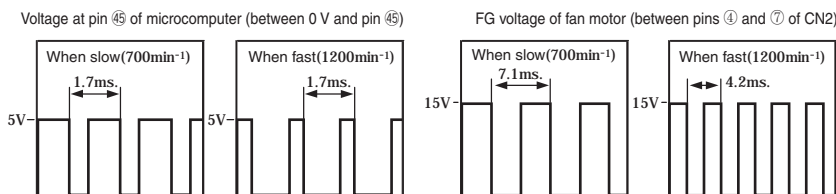


Fig. 3-2

- The indoor fan motor receives VDC (motor drive power supply), VCC (power supply for the control circuit inside the motor), and VS (speed command voltage) from CN2. The indoor fan motor returns an FG signal of a frequency that matches the rotation speed.
- VCC stabilizes the primary 18.5 V power supply into 15 V by using Q201 and supplies it.
- While on standby for a remote control signal, the Q201 shuts down the VCC and reduces the standby power.
- The VS receives a command voltage from the microcomputer (IC601). The VS terminal undergoes an analog voltage that matches the Lo level time ratio of the pulse signal from pin ④5 of the microcomputer. (See Fig. 3-2.)
- The FG terminal undergoes a signal of 12 pulses per revolution of the motor shaft. By counting the pulse rate, the microcomputer (IC601) recognizes the motor speed, thereby performing feedback control.

**Caution**

The indoor fan motor and drive circuit are connected to the primary power supply. They therefore have voltage to ground. Guard against electric shocks.

**Caution**

While the product is energized, do not under any circumstances detach or reattach a connector. Any such practice would cause a high voltage to run, resulting in the indoor fan motor and board circuit being destroyed. (Check the discharge of the C003 before detaching or reattaching the connectors.)

### 4. Buzzer Circuit

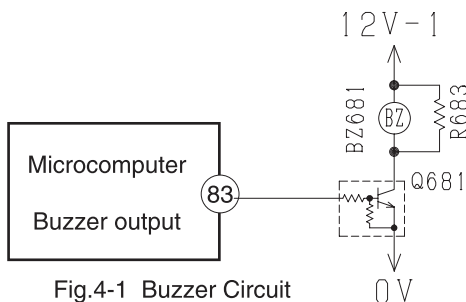


Fig.4-1 Buzzer Circuit

- When the buzzer sounds, an approx. 3.9kHz square signal is output from buzzer output pin (83) of the micro computer. After the amplitude of this signal has been set to 12Vp-p by a transistor, it is applied to the buzzer. The piezoelectric element in the buzzer oscillates to generate the buzzer's sound.

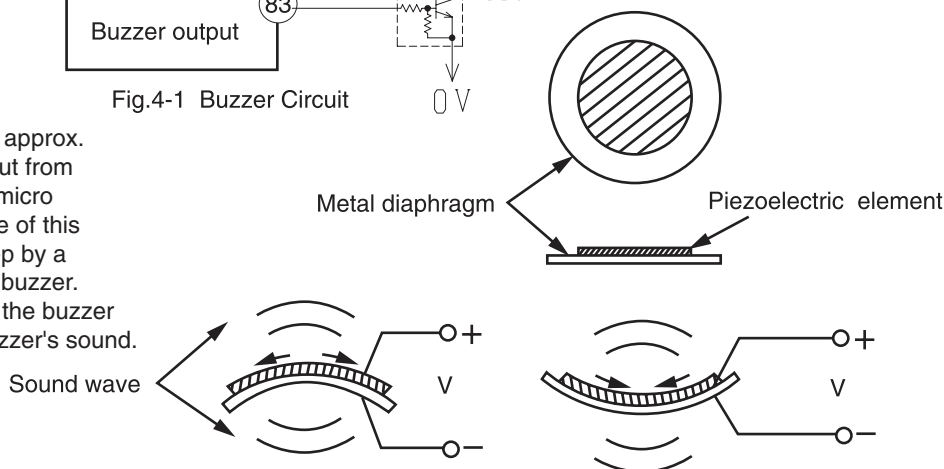


Fig.4-2 Buzzer Operation

### 5. Remote control reception circuit

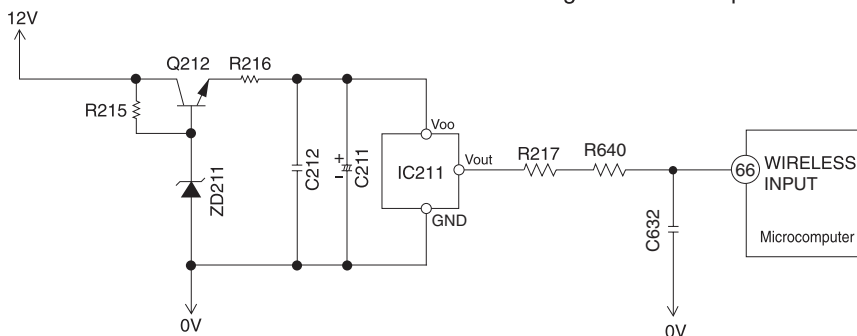


Fig.5-1

[Typical communication waveform]

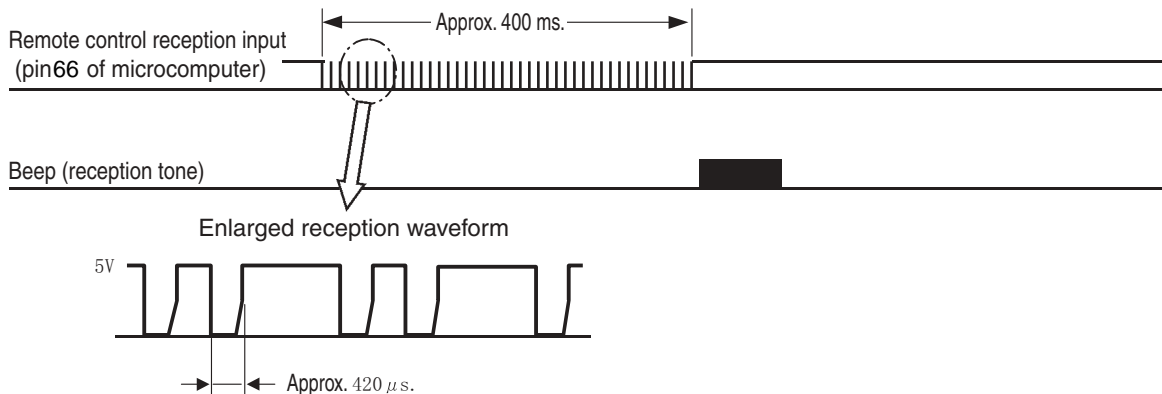
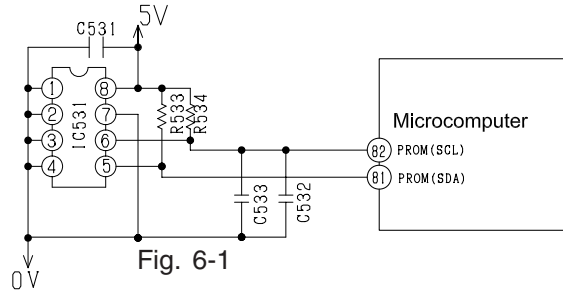


Fig. 5-2

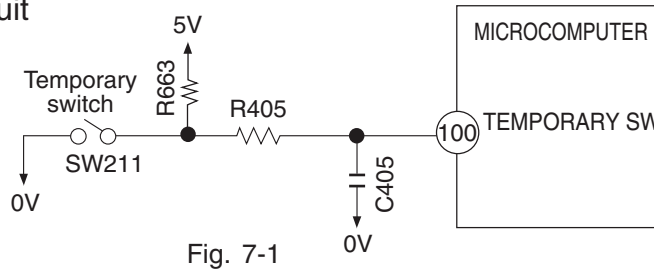
- An infrared signal from the remote control unit is converted to an electrical signal by the remote control light-receiving unit (IC821) and is received by the microcomputer. Data is transmitted as digital data 0 and 1 by changing the interval of the basic pulses at about 420μs.

## 6. Initial Setting Circuit (IC531)

- When power is supplied, the microcomputer reads the data in IC531 (E<sup>2</sup>PROM) and sets the preheating activation value and the rating and maximum speed of the compressor, etc. to their initial values.
- Data of self-diagnosis mode is stored in IC531; data will not be erased even when power is turned off.



## 7. Temporary Switch Circuit

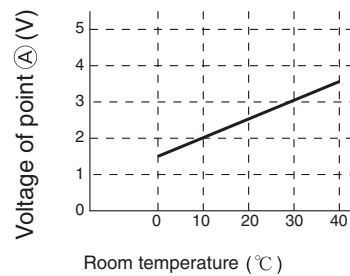
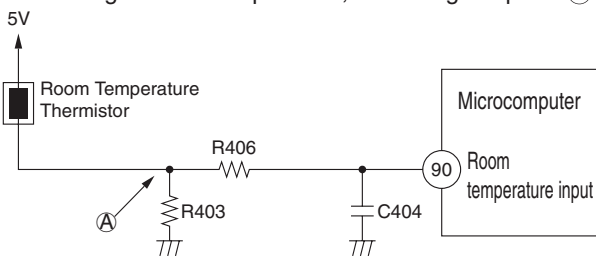


- The temporary switch is used to operate the air conditioner temporarily when the wireless remote control is lost or faulty.
- The air conditioner operates in the previous mode at the previously set temperature. However, when the power switch is set to OFF, it starts automatic operation.

## 8. Room Temperature Thermistor Circuit

A room temperature thermistor circuit is shown in Fig. 8-1.

According to room temperature, the voltage of point (A) becomes as it is shown in Fig.8-2.

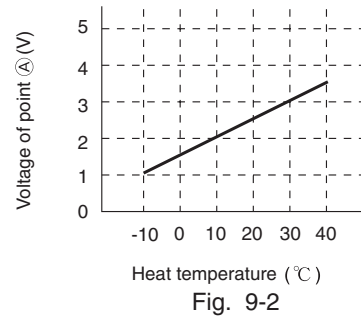
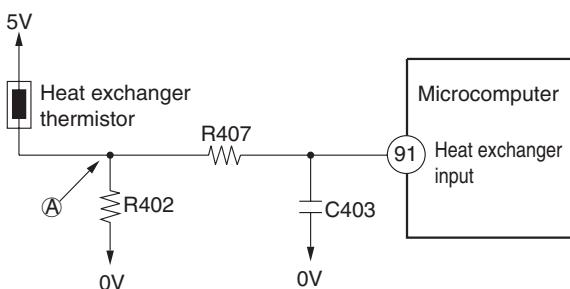


## 9. Heat Exchanger Thermistor Circuit

Heat exchanger temperature is noticed inside the room

- (1) Preheating
- (2) Low-temperature defrosts at cooling and dehumidification operation time.
- (3) Not working of reversing valve or detection of opening of heat exchange thermistor is controlled.

According to heat exchange temperature, the voltage of point (A) becomes as it is shown in Fig. 9-2.



## 10. Dip-switch

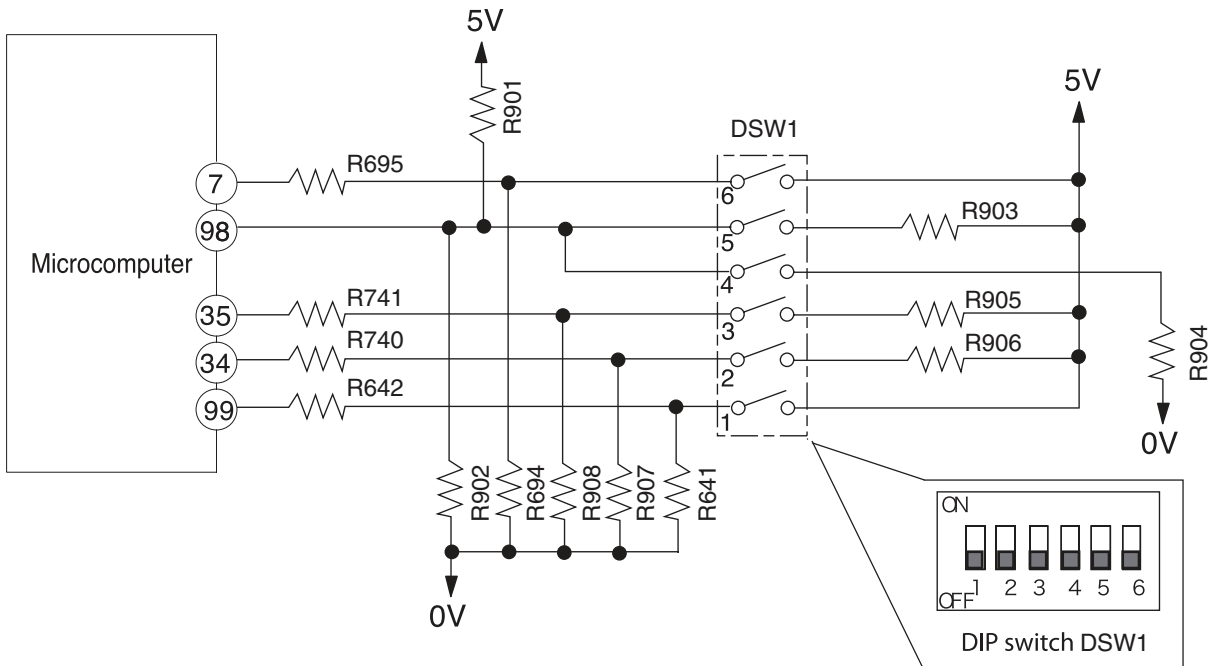


Fig.10-1 Dip switch Circuit

- Fig.10-1 shows the dip switch circuit; the table shown in Fig.10-2 are function and setting position from ①–⑥ of the switch no.

SW No.	I T E M	F U N C T I O N							
		OFF*	ENABLE	ON	DISABLE				
1	AUTO RESTART	OFF*	ENABLE	ON	DISABLE				
2	CARD KEY MODE	OFF*	DISABLE	ON	ENABLE				
3	CARD KEY LOGIC SELECT	OFF*	INPUT HIGH ACTIVE	ON	INPUT LOW ACTIVE				
4	HEATING/COOLING ONLY MODE SELECT	OFF*	HEATING & COOLING	OFF	HEATING ONLY	ON	COOLING ONLY	ON	HEATING & COOLING
5	HEATING/COOLING ONLY MODE SELECT	OFF*		ON		OFF		ON	
6	REMOCON ID SELECT	OFF*	SELECT ID : A	ON	SELECT ID : B				

Fig.10-2 Functions of Dip switch

NOTE:

\* Marking is position of shipping [FACTORY default setting]

# 11. Indoor/outdoor communication circuits

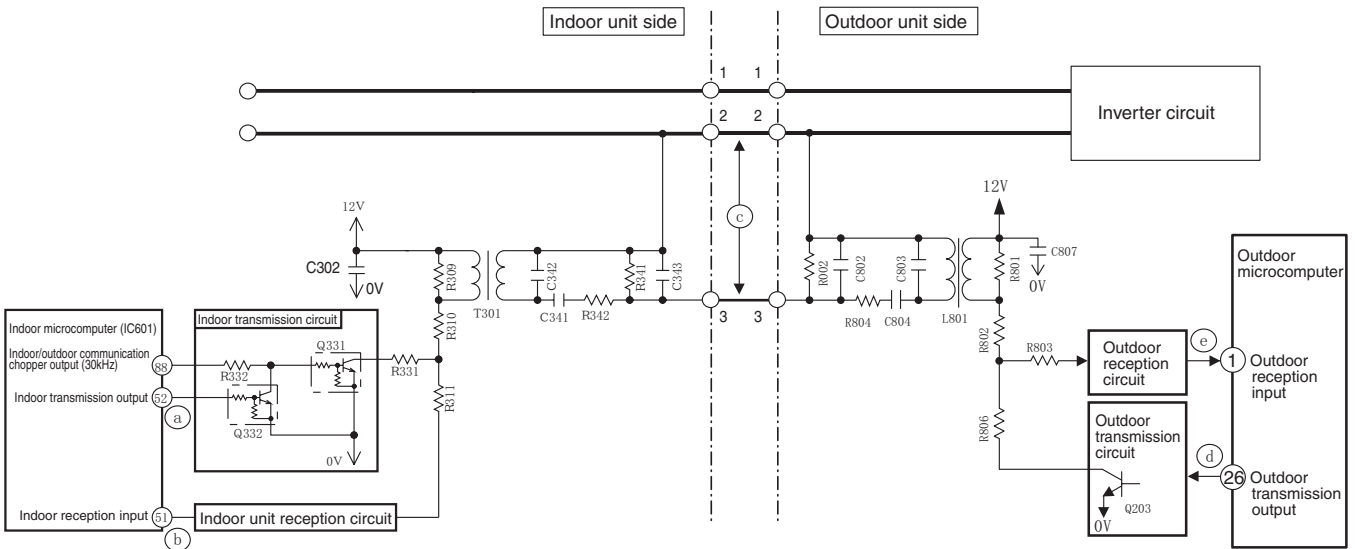


Fig. 11-1

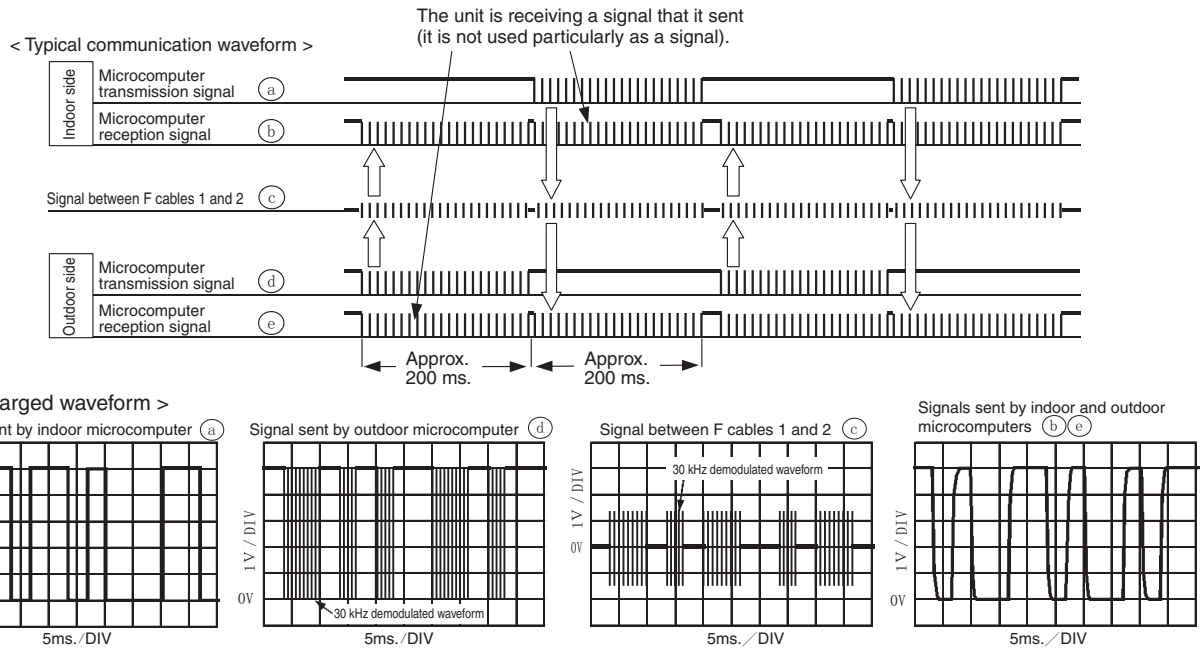


Fig. 11-2

- Indoor and outdoor communications are conducted by using lines 2 and 3 of F cable. Line 2 of F cable is shared with a transmission channel that powers the outdoor unit.
- Data communicated between the indoor and outdoor units are outputted from the microcomputer as serial signals and are transmitted as demodulated by a 30 kHz carrier wave. (Both the indoor and outdoor microcomputers directly output a signal demodulated at 30 kHz.)

**Check**

If a cable poorly inserted in the indoor terminal board or some other failure overheats the terminal board and the temperature fuse of the terminal board blows out, the power to the indoor communication circuit will be shut down to stop the communications function. (In that case, the failure will be displayed by the timer lamp blinking 3 times.)

**Check**

If communication fails between the indoor and outdoor units for some reason, the product will give a self-diagnosis display either by "the timer lamp blinking 3 times" or "the timer lamp blinking 12 times" depending on the cause.

## 12. Stepping motor drive circuit

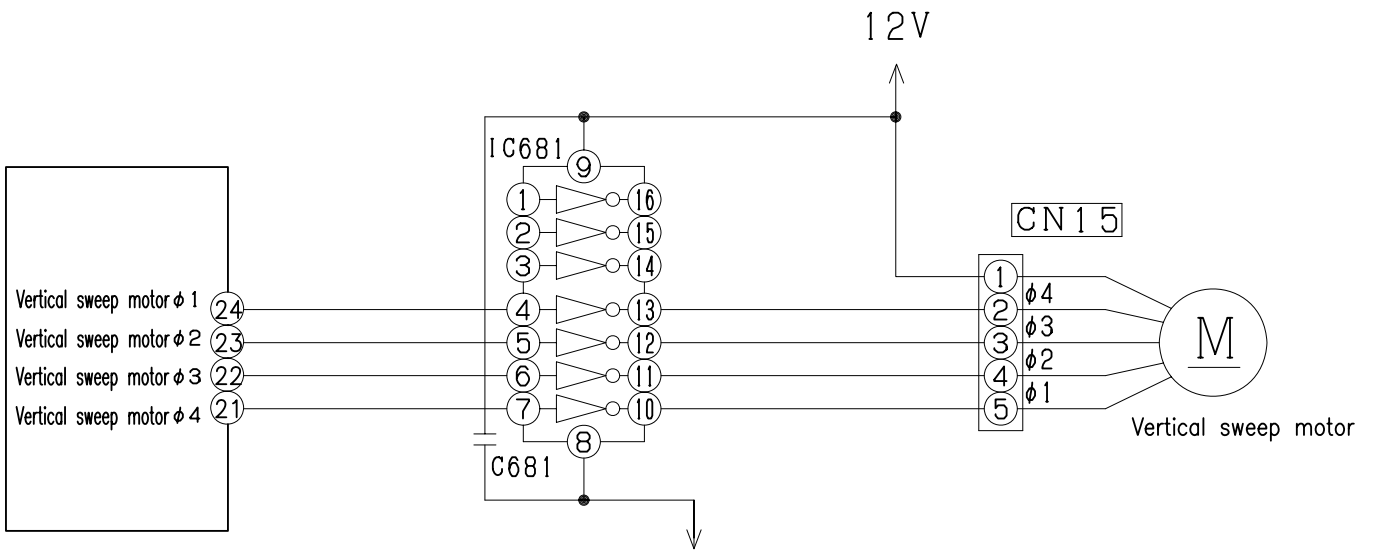


Fig. 12-1

[Connector circuit waveform while the motor runs]

Voltage waveforms of different phases as viewed from the OV line while the motor rotor is turning counterclockwise as viewed from the shaft side

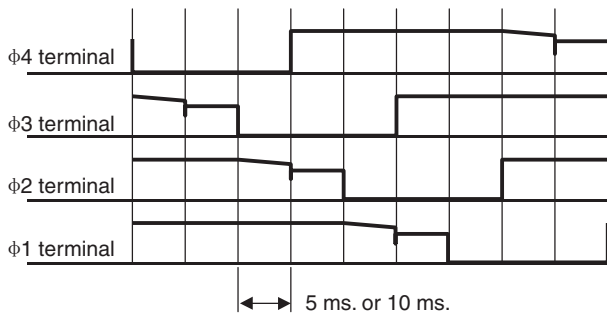


Fig. 12-2

- Each stepping motor runs as excited in 1 or 2 phases at 100 PPS or 200 PPS.
- The excitation pattern passes the microcomputer (IC601) and then the driver IC and excites the coil of each stepping motor.

### 13. Run status and alarm signal output circuit

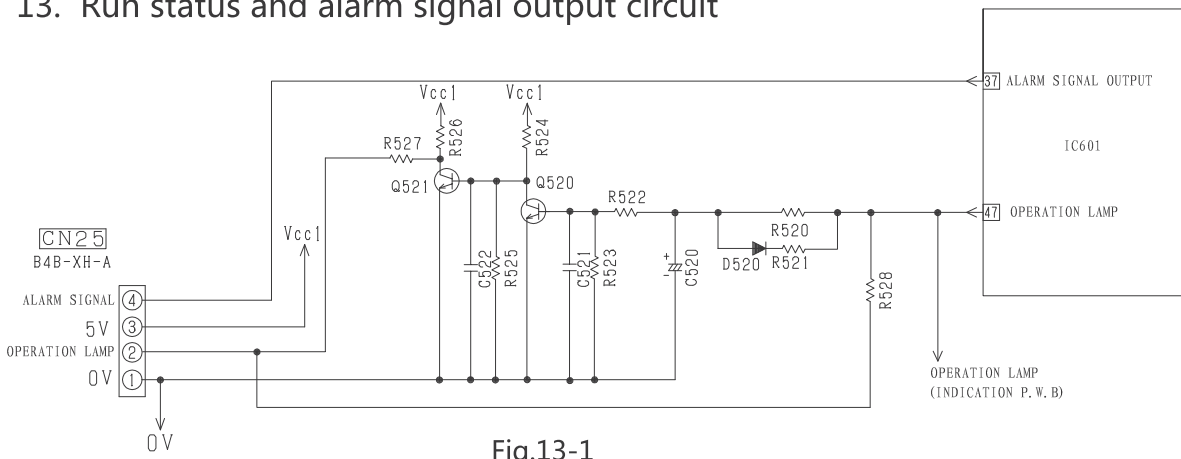


Fig.13-1

Fig.13-1 is the control circuit of run status and signal output in main PWB. The pin ② of CN25 is used to show run status and the pin ④ of CN25 is used to warn people when failure occurrence. If customer want to use this function, need to use the adapter (sold separately) to achieve it. the adapter is optional and the detail circuit refer to following circuit.

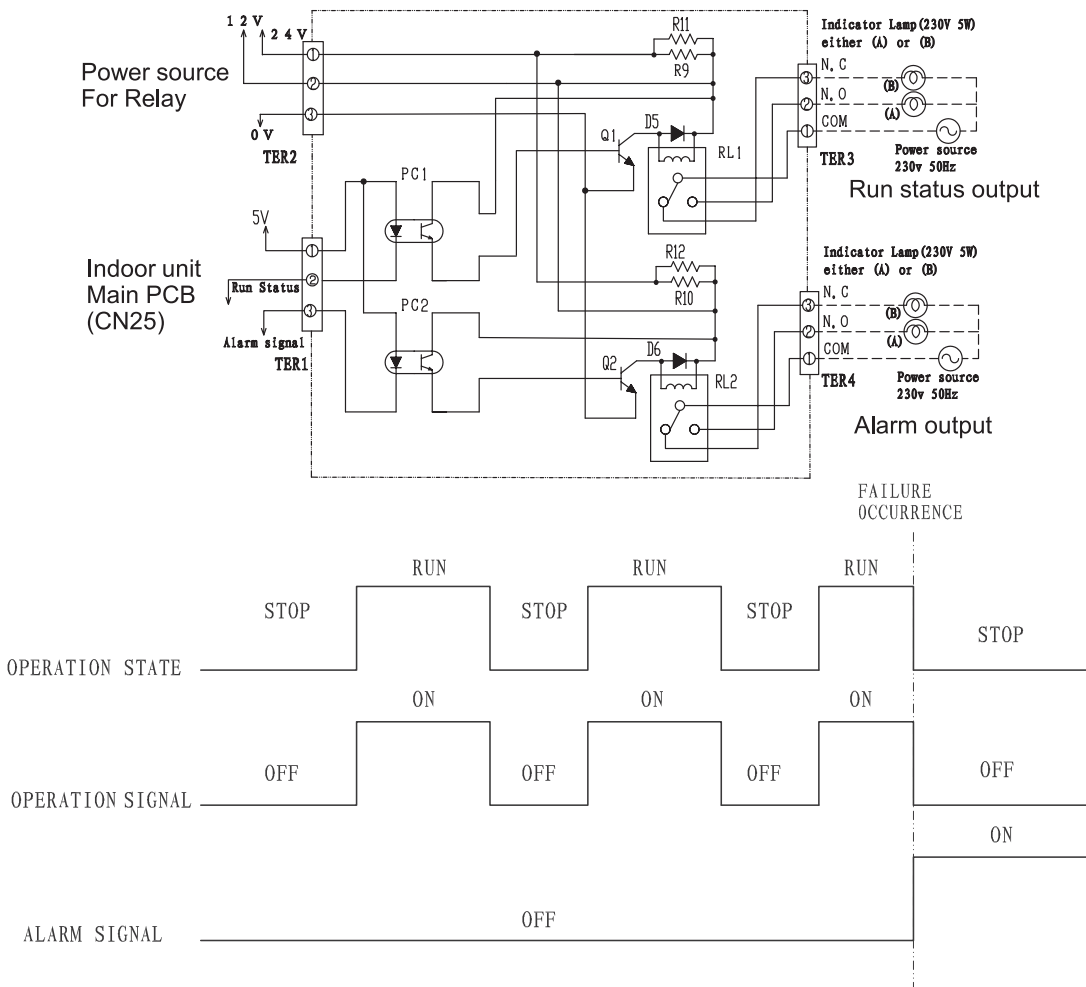
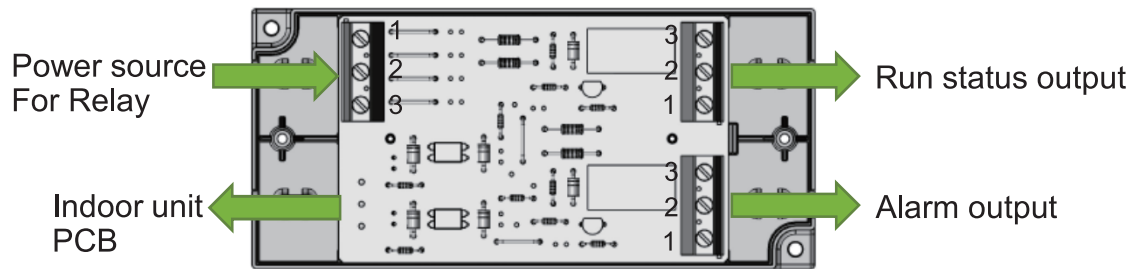


Fig.13-2

RL1 is on When air-condition is running and is off When air-condition is stopping. We can know the status of air-condition by RL1. RL2 is off When air-condition in normal condition and is on when air-condition in failure occurrence, we can repair it in time.



- When operating RAC, Run Status signal is output.
- When operation stops, the signal disappears.
- When RAC gets malfunction, alarm signal is output.
- Each signal has to be taken out through the Adapter.

※ The adapter must to be used because of noise interference. The noise will cause air-condition failure. the voltage from customer's home supply to adapter must be in the 5 ~ 24V, the current is less than 10mA. If the voltage is lower than 5V, optocouplers will not be action; once the voltage is higher than 24V, optocouplers adapter will be damaged.

Load side is a high voltage line, please be careful from electric shock and install the Indication Lamp as near as possible to the Relay Kit. The maximum length of the wiring cable should be below 100m.



# MODEL RAC-18/25/35WED

## 1. Power Circuit

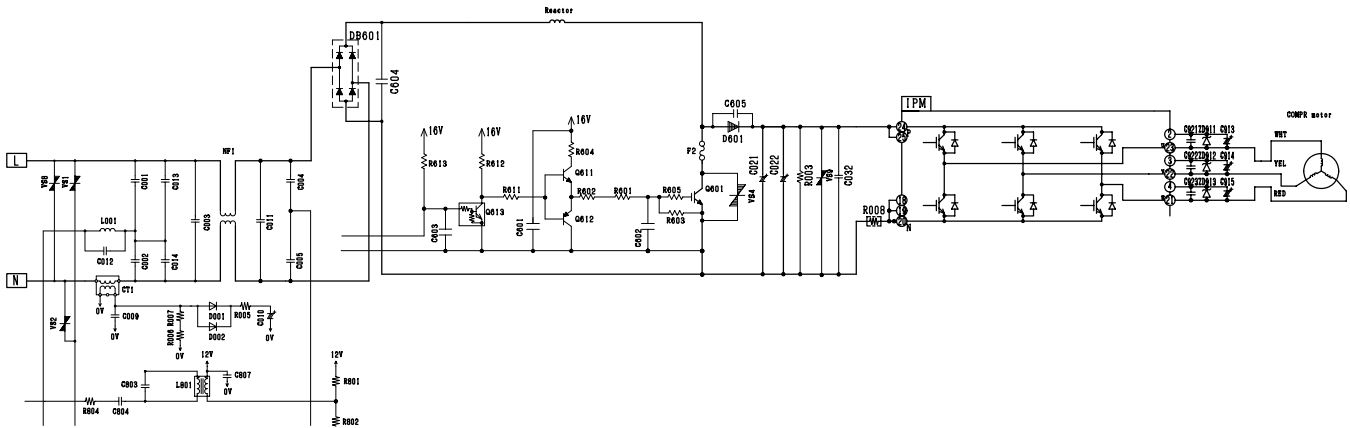


Fig 1-1

※ This circuit full-wave rectifies 230VAC applied between terminals L and N and boosts it to a required voltage with the IPM to create a DC voltage.

The voltage become 300-330V when the compressor is operated.

### ※ Main parts

- ( 1 ) Intelligence Power Module (IPM)  
A module that constitute by an inverter part.
- ( 2 ) Diode Stack (DB601)  
These rectify the 230VAC from terminal L and N to a DC power supply.
- ( 3 ) Smoothing capacitors (C021-C022,375 $\mu$ F,420V)
- ( 4 ) IGBT to improve efficiency (Q601)

### <Reference>

※ In case of Intelligence Power Module malfunction or connection failure immediately after compressor starts, its may stop due to error of [abnormal low speed],[switching failure],[Ip stop] and others.

### <Reference>

※ If diode stack (DB601) are faulty, DC voltage may not be generated and the compressor may not operate at all. Also be aware that the 15A fuse might have blown.

※ This smoothes (averages) the voltage rectified by the diode stack.

※ It will improve the efficiency during compressor load become heavy when current flow thru the chopper period of Q601.

## 2. Power circuit (Low voltage)

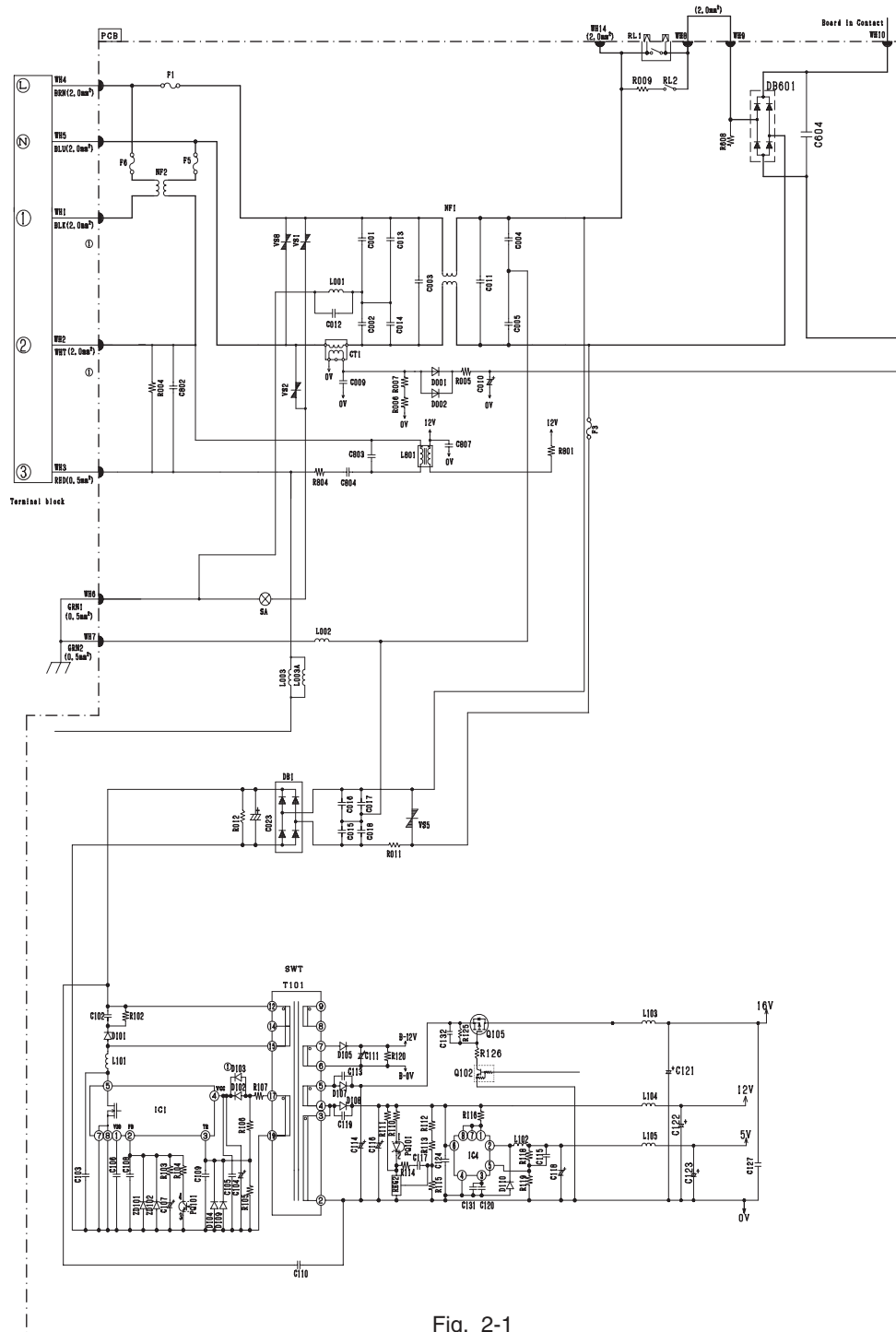


Fig. 2-1

- The 230V AC voltage is rectified to DC voltage (B-12V,16V,12V,5V) pass through switching control IC (IC1), switching transformer.

- (1) B-12V Power supply for electrical expansion valve.
- (2) 16V Power supply for IPM driver circuit of compressor and fan motor, IGBT action.
- (3) 12V Power supply for 4 way valve relay, power relay, inrush current relay, motor current amplification,
- (4) 5V Power supply for microcomputer, peripheral circuits.

## Main parts

(1) C001,C002,C003,C004,C005,C011,C013,C014, NF1

These absorb electrical noise generated during operation of compressor and also absorb external noise entering from power line to protect electronic parts.

(2) Surge Absorber, Varistor1,2,5,8.

These absorb external power surge.

(2) IC4

DC/DC convertor IC (DC12V → DC5V).

### 3. P.W.B. for power circuit

Voltage specification of power circuit as shown in below table.

<Checking point>

Output	Spec	Main load	Measuring point	Example of possible failure mode.
5V O/P	$5 \pm 0.4V$	Micon, Thermistor	Tester⊕ : L105 (JUMPER) Tester⊖ : D110 (EARTH)	Outdoor not operate, no blinking indication
12V O/P	$12 \pm 0.5V$	Micon, IC2, 3, 4 Relay circuit	Tester⊕ : L104 (JUMPER) Tester⊖ : D110 (EARTH)	Outdoor not operate, no blinking indication
16V O/P	$15.5^{+1.5V}_{-1.0V}$	IPM for Comp IPM for DC fan	Tester⊕ : L103 (JUMPER) Tester⊖ : D110 (EARTH)	Stop : LD301 3,4 or 12 times blinking
B-12V O/P	$13^{+2.5V}_{-1.0V}$	Expansion valve	Tester⊕ : R120 (B-12V) Tester⊖ : R120 (B-0V)	Stop : LD301 5 times blinking

※ Power circuit for P.W.B can consider normal if the result is satisfied with above specification.

4.Reversing valve control circuit

This model reversing valve control used to control the relay ON/OFF of the revesing valve, and also control the coil of the reversing valve ON/OFF.

The relay ON/OFF has different type when in the different operation mode.

You can see each operation mode as flows. If the reaversing valve not connected or all the condition not the same as follow, it may be something wrong with the reversing valve circuit.

Point operation mode		micon (28pin - 0V	HIC (34 pin - 0V	CN2(1)- CN2(4)
		Cooling	Usual cooling	Hi
Heating	Usual heating	Lo	12V	0V
	Defrost	Hi	0V	AC230V

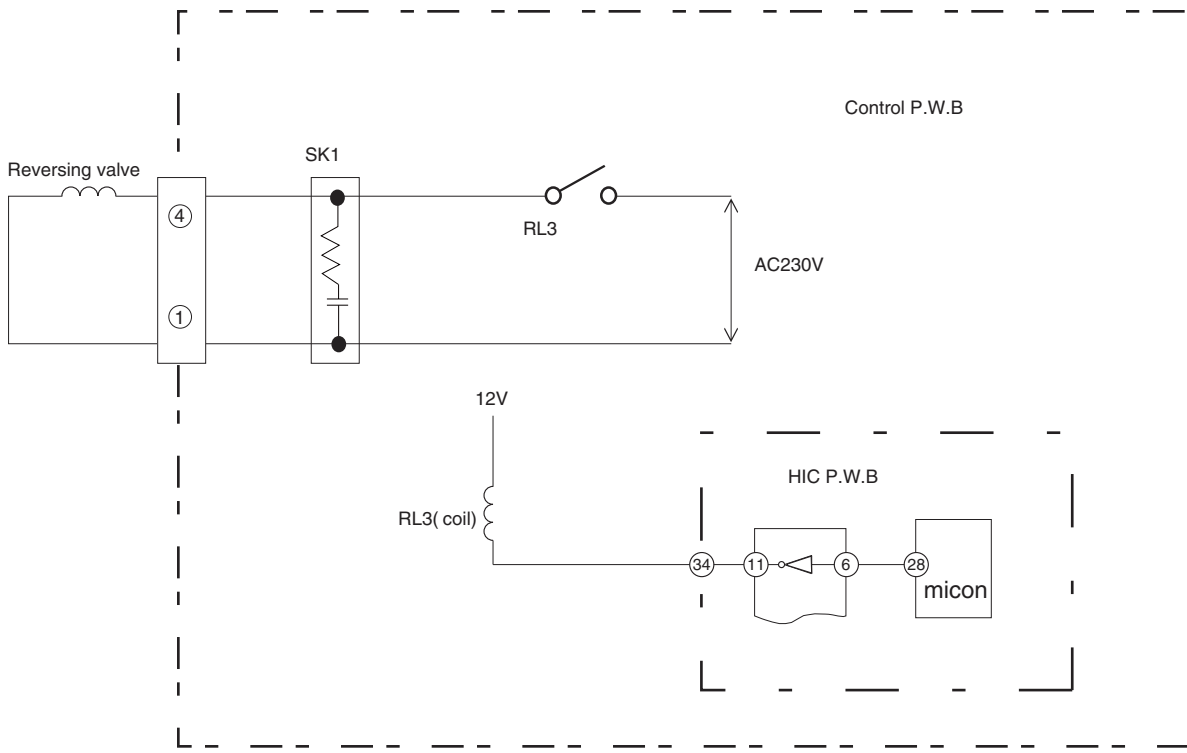


Fig.4-1

## 5. Temperature Detection Circuit

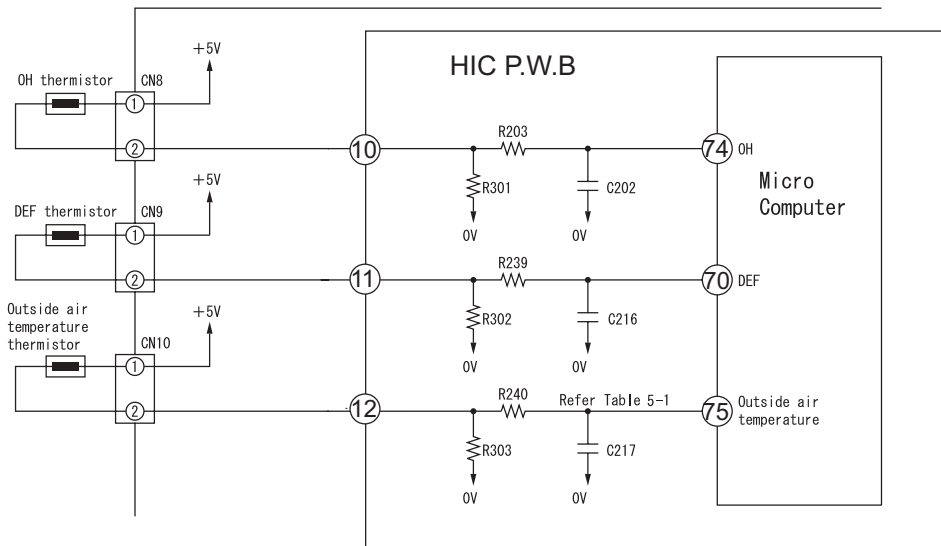


Fig.5-1

- OH thermistor circuit detect the temperature at the surface of compressor head, DEF thermistor circuit detect the defrosting operation temperature.
- A thermistor is a negative resistor element which has characteristics that the higher(lower) the temperature, the lower(higher) the resistance.
- When the compressor is heated, the resistance of the OH thermistor becomes low and  $\oplus 5V$  is divided by OH thermistor and R301 and the voltage at pin (74) of microcomputer.
- Compare the voltage at microcomputer pin (74) and setting value stored inside. If the value exceed the set value, microcomputer will judge that the compressor is overheated and stop the operation.
- When frost is formed on the outdoor heat exchanger, the temperature at the exchanger drops abruptly. Therefore the resistance of the DEF thermistor becomes high and the voltage at pin (70) of micro computer drops. If this voltage becomes lower than the set value stored inside, microcomputer will enter the defrost control.
- During defrost operation, the microcomputer will transfer the defrosting condition command to indoor unit via SDO pin of interface of IF transmission output.
- The microcomputer read the outdoor temperature by Outside Air thermistor and transfer it to the indoor unit, thus controlling the compressor rotation speed according to the set value in the EEPROM of indoor unit and switching the operation mode (outdoor fan on/off etc.) to DRY mode.

Below table show the typical values of outdoor temperature in relation to the voltage.

Table 5-1

Outside Air Temperature (°C)	-10	0	10	20	30	40
Voltage at both side of R303 (V)	1.19	1.69	2.23	2.75	3.22	3.62

<Reference>

When the thermistor is open, open condition or disconnect, microcomputer pin(70)(74)(75) are approx. 0V;

When thermistor is shorted, they are approx. 5V and LD301 will blink 7 times.

However, an error is detected when only the OH thermistor is shorted and will enter blinking mode after 12 minutes start the compressor operation.

## 6. Electric expansion valve circuit

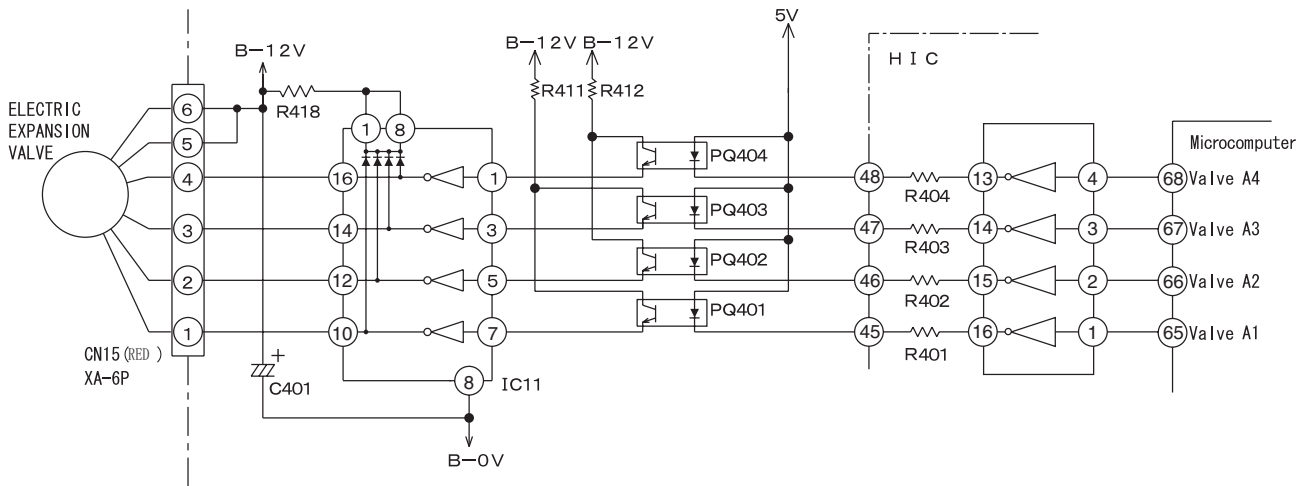


Fig. 6-1

- The electric expansion valve is driven by DC12V. Power is supplied to 1 or 2 phases of 4-phase winding to switch magnetic pole of winding in order to control the opening degree.
- Relationship between power switching direction of phase and open/close direction is shown below. When power is supplied, voltages at pins ④ to ① of CN15 are about 0.9V and 12V when no power is supplied. When power is reset, initial operation is performed for 10 or 20 seconds. During initial operation, measure all voltages at pin ④ to ① of CN15 by using a multimeter. If there is any pin with voltage that has not changed from 0.9V or 12V, expansion valve or microcomputer is broken.
- Fig. 6-2 shows logic waveform when expansion valve is operating.

Table 6-1

CN15 pin no.	Wire	Drive status							
		1	2	3	4	5	6	7	8
①	WHT	ON	ON	OFF	OFF	OFF	OFF	OFF	ON
②	YEL	OFF	ON	ON	ON	OFF	OFF	OFF	OFF
③	ORG	OFF	OFF	OFF	ON	ON	ON	OFF	OFF
④	BLU	OFF	OFF	OFF	OFF	OFF	ON	ON	ON

Operation mode  
 1→2→3→4→5→6→7→8 VALVE CLOSE  
 8→7→6→5→4→3→2→1 VALVE OPEN

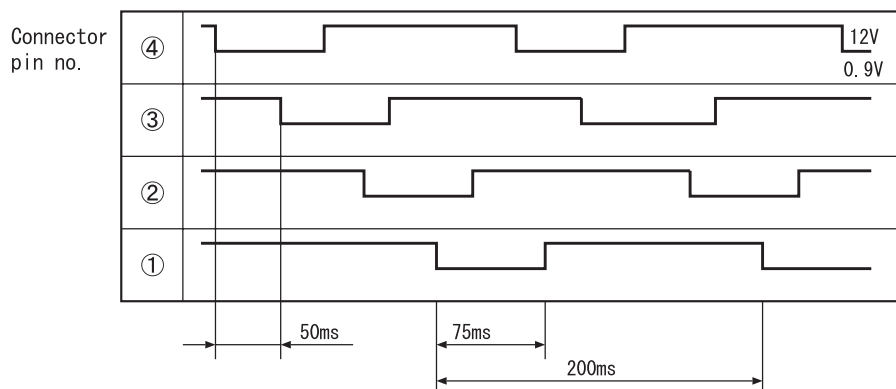


Fig. 6-2

With expansion valve control, opening degree is adjusted to stabilize target temperature by detecting compressor head temperature. The period of control is about once per 20 seconds and output a few pulse.

## 7. Outdoor DC fan motor control circuit

- This model is built with DC fan motor control circuit inside outdoor electrical unit.

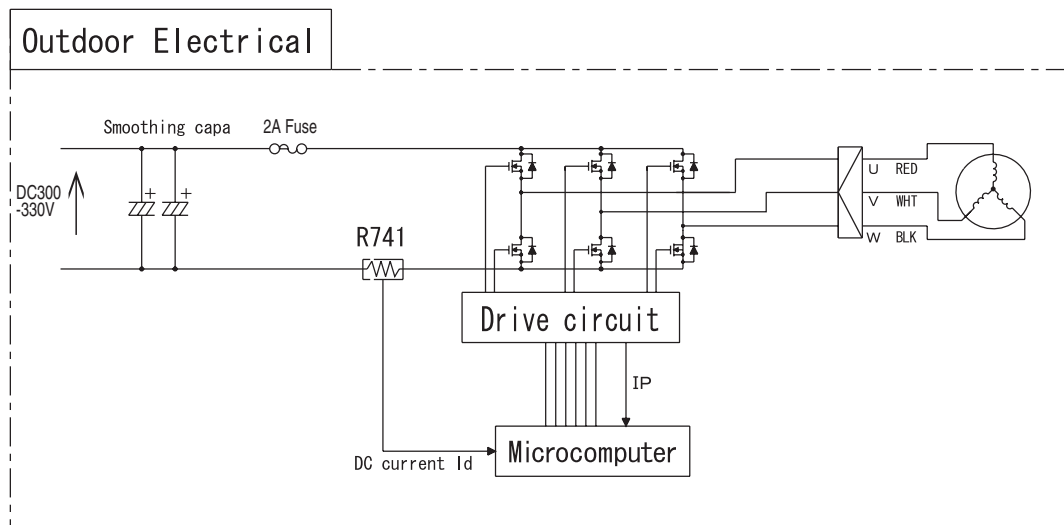


Fig 7-1

This DC fan motor is control by outdoor microcomputer that follow the operating instruction received from indoor microcomputer. The DC current that flow from R741 will presume actual operation speed and control the rotation to follow the operating instruction. Based on this DC current it will detect a over current and other fan motor failure.

### (1) Fan motor speed controller during starting

Due to the interference of strong wind etc., operation movement is changed based on fan direction and rotation speed as shown below during starting of operation.

In addition, the fair wind is define as wind that blow to outside direction using Mouth Ring part. At strong and contrary wind ... The rotational speed is not controlled as to protect the equipment and fan will rotate reversely depend on the wind. Automatically start when wind condition become weak.

At contrary wind ... The rotational speed is controlled in fair wind direction after it slowly reduce the speed and finally stop.

At fair wind ... The rotational speed is controlled as it is.

At strong fair wind ... The rotational speed is not controlled as to protect the equipment and fan will rotate reversely depend on the wind. Automatically start when wind condition become weak.

### (2) Fan motor speed controller during unit operating

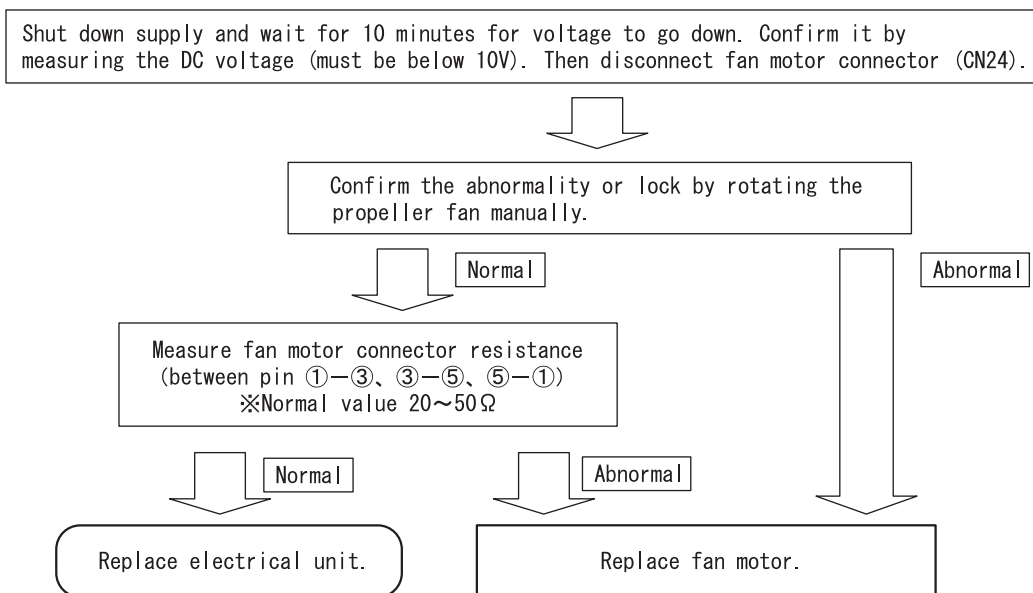
There is a case where fan rpm is reducing during rotating caused by interference of strong wind. If this condition continue in long period, fan will stop rotating. (LD301 : 11 times blinking)  
The unit will restart according to control as per during start (1).

(3) Method of confirming self diagnosis LD301 lamp : 12 times blinking

If the unit stop and LD301 on the pwb blinking 12 times [fan lock stop is detected], follow below steps to confirm it.

1. Fan lock stop is detected when something has disturb the fan rotation by inserting material into propeller fan or ice has growing inside outdoor unit caused by snow.  
Remove it if found something is bloking the fan.
2. Confirmed that CN24 connector is securely inserted. Fan lock stop is detected also when connector is not properly inserted. Please securely insert if found any disconnection.
3. Fan lock stop also can be detected where strong wind blown surrounding the unit.  
Please confirm after restart the unit. (It may take few minutes to operate the compressor)  
It is not a malfunction of electrical unit or fan motor if the unit run continously after restart the unit.
4. Check fan motor condition as below procedure.

[Checking Fan Motor] procedure



5. Reconnect again fan motor connector (CN24).

※Please confirm above checking procedure if found 2A fuse blown.

If fan motor is broken, replace both electrical unit and fan motor.

Caution

※Beware of electric shock due to high voltage when conducting an operation check.

Power supply for DC fan motor and compressor is common (DC300-330V).



# MODEL RAC-50WED

## 1. Power Circuit

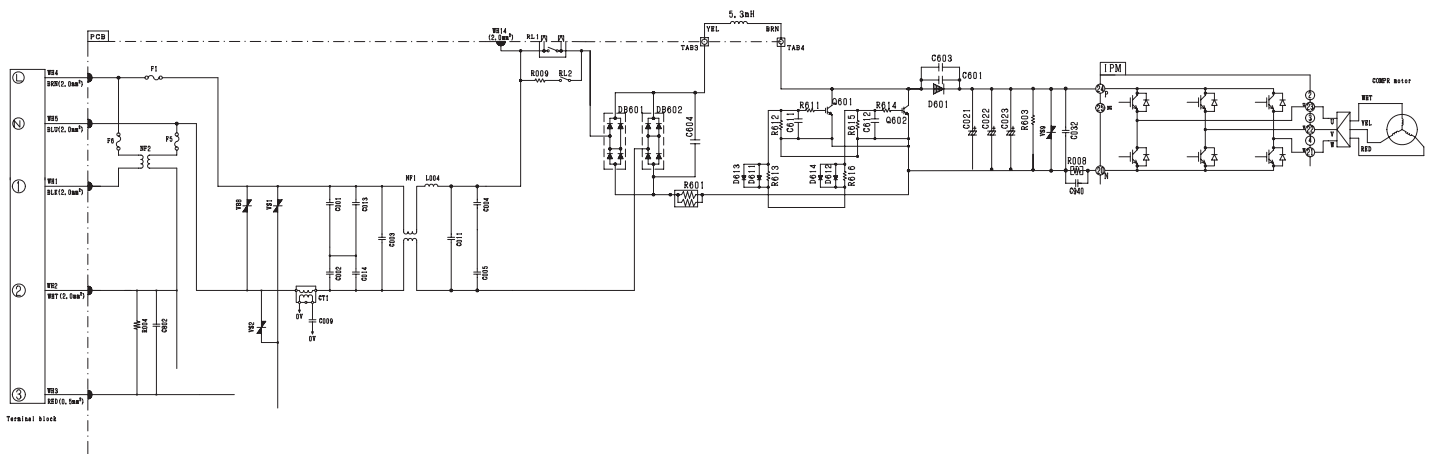


Fig 1-1

※ This circuit full-wave rectifies 230VAC applied between terminals L and N and boosts it to a required voltage with the IPM to create a DC voltage.

The voltage become 300-330V when the compressor is operated.

※ Importance component

- ( 1 ) Intelligence Power Module (IPM)  
A module that constitute by an inverter part.
- ( 2 ) Diode Stack (DB601, DB602)  
These rectify the 230VAC from terminal L and N to a DC power supply.

<Reference>

※ In case of Intelligence Power Module malfunction or connection failure immediately after compressor starts, its may stop due to error of [abnormal low speed], [switching failure],[Ip stop] and others.

<Reference>

※ If diode stack (DB601, DB602) are faulty, DC voltage may not be generated and the compressor may not operate at all. Also be aware that the 25A fuse might have blown.

(3) Smoothing capacitors (C021-C023, 500 $\mu$ F, 450V)

This smoothes (averages) the voltage rectified by the diode stack.

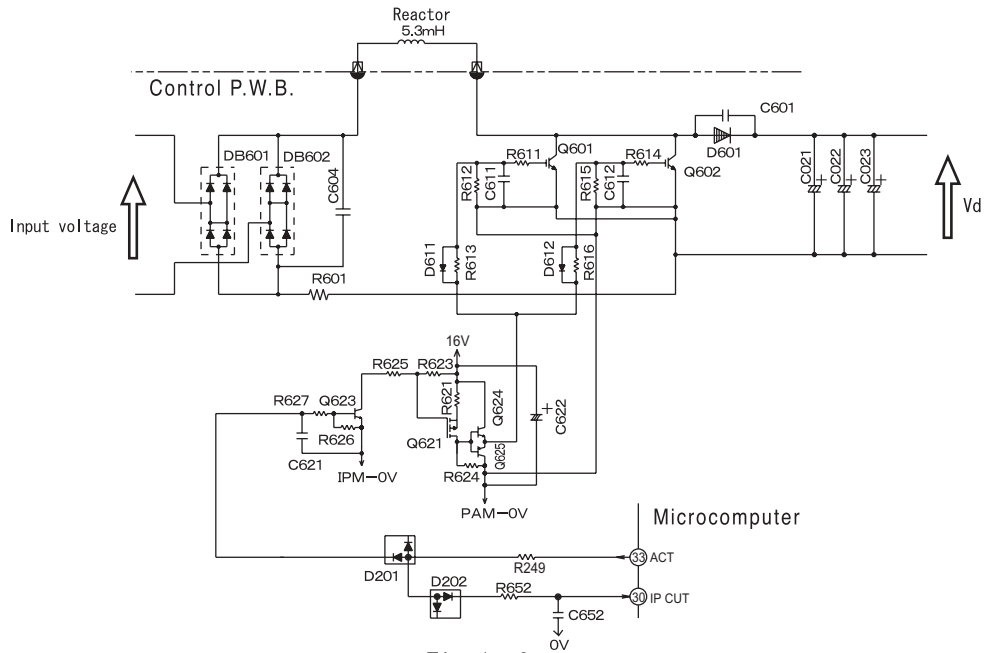


Fig. 1-2

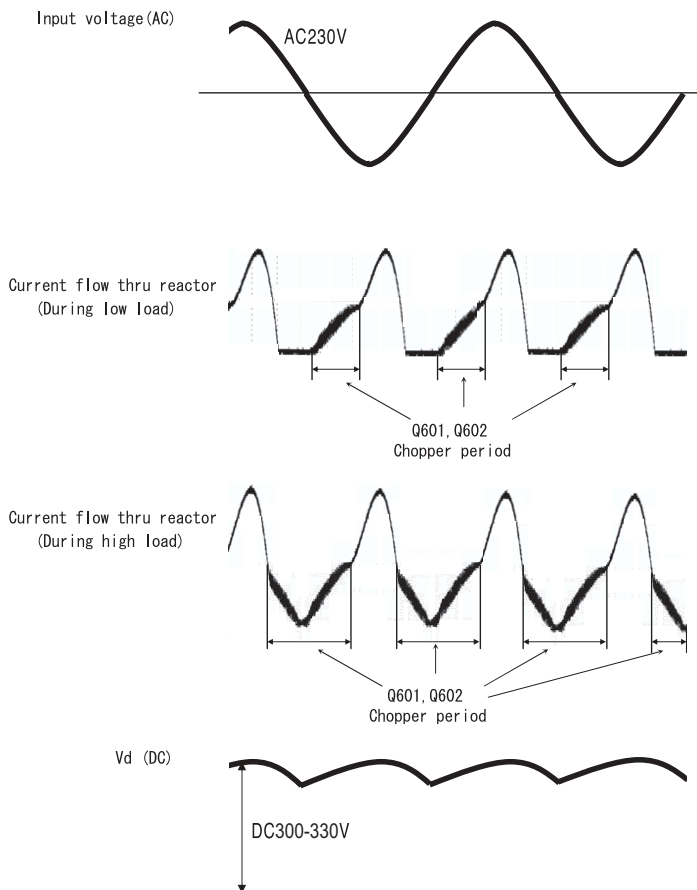


Fig. 1-3

(4) IGBT to improve efficiency (Q601, Q602)

It will improve the efficiency during compressor load become heavy when current flow thru the chopper period of Q601, Q602.

## 2. Power circuit (Low voltage)

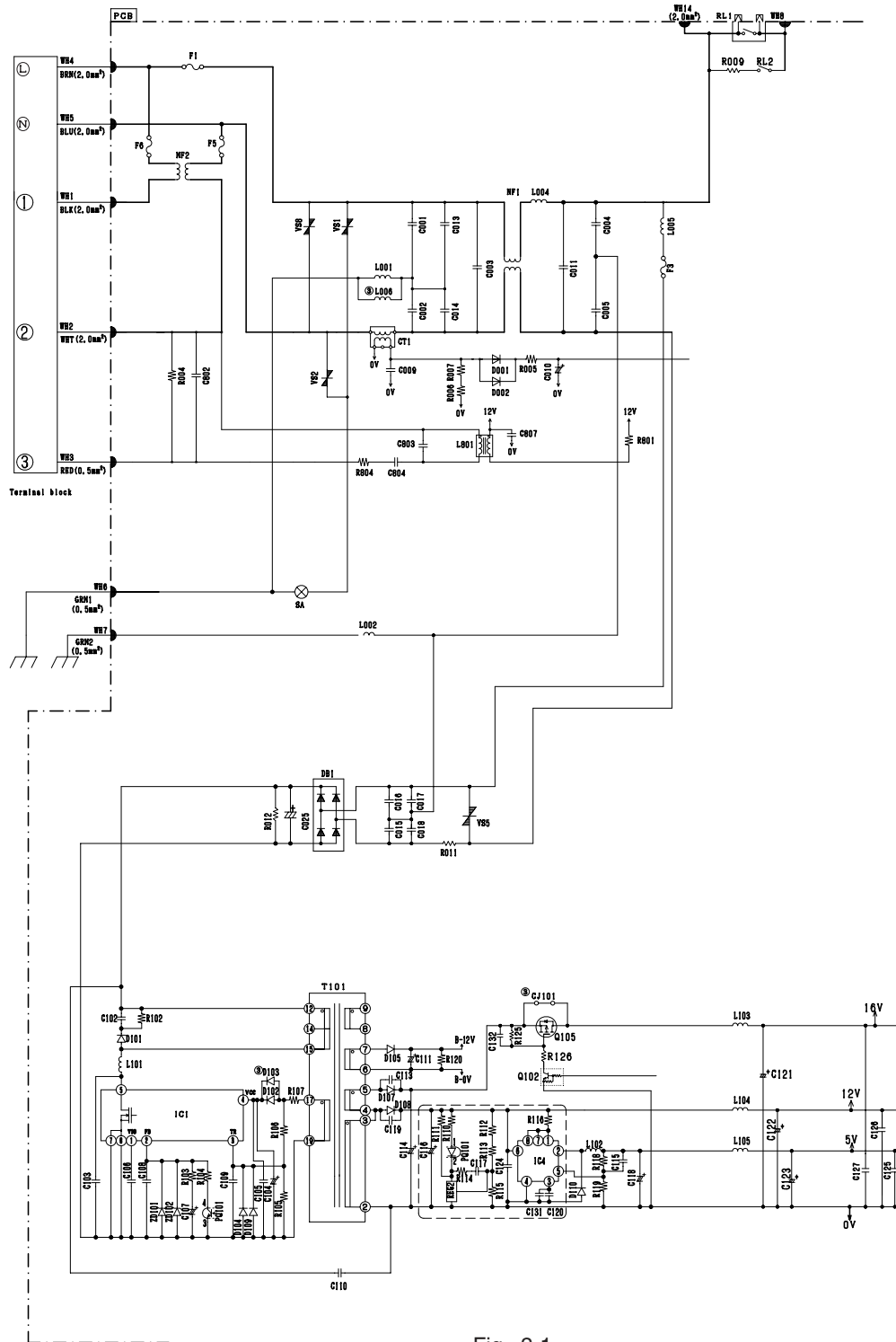


Fig. 2-1

- The 230V AC voltage is rectified to DC voltage (B-12V,16V,12V,5V) pass through switching control IC (IC1), switching transformer.
- (1) B-12V Power supply for electrical expansion valve.
- (2) 16V Power supply for IPM driver circuit of compressor and fan motor, IGBT action.
- (3) 12V Power supply for 4 way valve relay, power relay, inrush current relay, motor current amplification,
- (4) 5V Power supply for microcomputer, peripheral circuits.

## Main parts

(1) C001,C002,C003,C004,C005,C011,C013,C014, NF1

These absorb electrical noise generated during operation of compressor and also absorb external noise entering from power line to protect electronic parts.

(2) Surge Absorber, Varistor1,2,5,8.

These absorbs external power surge.

(2) IC4

DC/DC convertor IC (DC12V → DC5V).

### 3. P.W.B. for power circuit

Voltage specification of power circuit as shown in below table.

〈Checking point〉

Output	Spec	Main load	Measuring point	Example of possible failure mode.
5V O/P	$5 \pm 0.4V$	Micon, Thermistor	Tester $\oplus$ : L105 (JUMPER) Tester $\ominus$ : D110 (EARTH)	Outdoor not operate, no blinking indication
12V O/P	$12 \pm 0.5V$	Micon, IC2, 3, 4 Relay circuit	Tester $\oplus$ : L104 (JUMPER) Tester $\ominus$ : D110 (EARTH)	Outdoor not operate, no blinking indication
16V O/P	$15.5^{+1.5V}_{-1.0V}$	IPM for Comp IPM for DC fan	Tester $\oplus$ : L103 (JUMPER) Tester $\ominus$ : D110 (EARTH)	Stop : LD301 3, 4 or 12 times blinking
B-12V O/P	$13^{+2.5V}_{-1.0V}$	Expansion valve	Tester $\oplus$ : R418 (B-12V) Tester $\ominus$ : C401 (" - ")	Stop : LD301 5 times blinking

※ Power circuit for P.W.B can consider normal if the result is satisfied with above specification.

#### 4.Reversing valve control circuit

This model reversing valve control used to control the relay ON/OFF of the revesing valve, and also control the coil of the reversing valve ON/OFF.

The relay ON/OFF has different type when in the different operation mode.

You can see each operation mode as flows. If the reaversing valve not connected or all the condition not the same as follow, it may be something wrong with the reversing valve circuit.

Point operation mode		micon ②⑧pin - 0V	HIC ②⑧ pin - 0V	CN2①- CN2④
		Cooling	Usual cooling	Hi
Heating	Usual heating	Lo	12V	0V
	Defrost	Hi	0V	AC230V

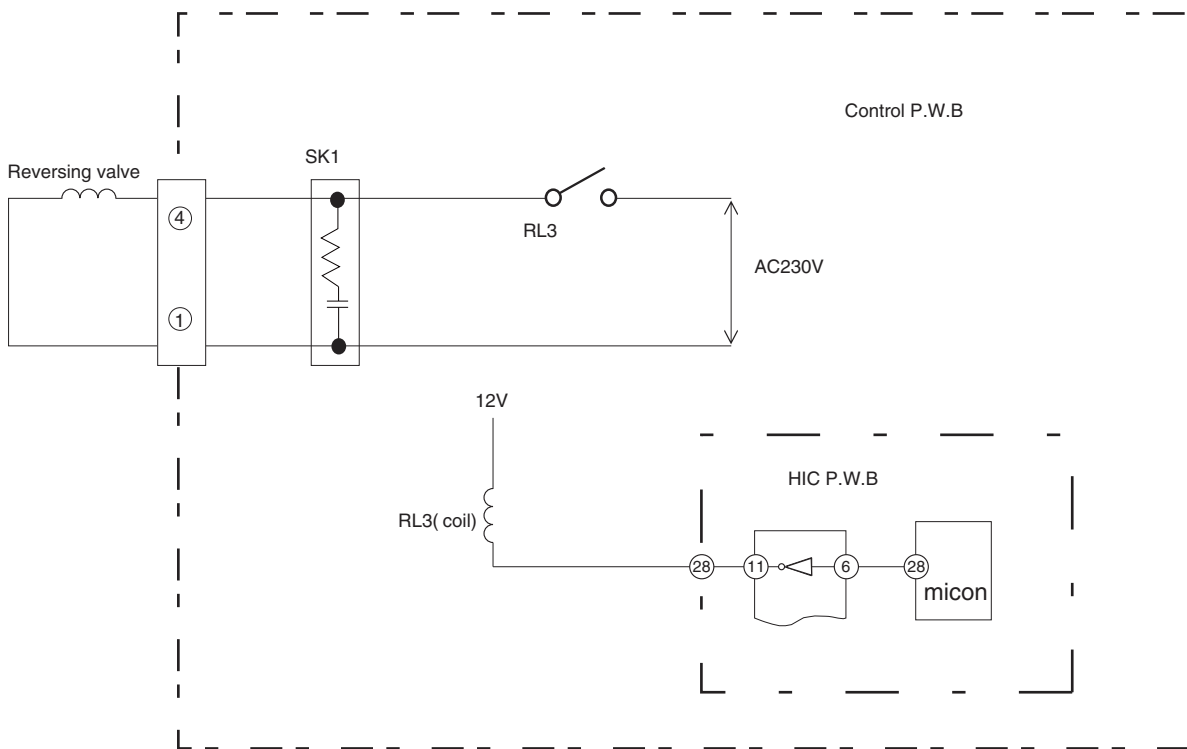


Fig.4-1

## 5. Temperature Detection Circuit

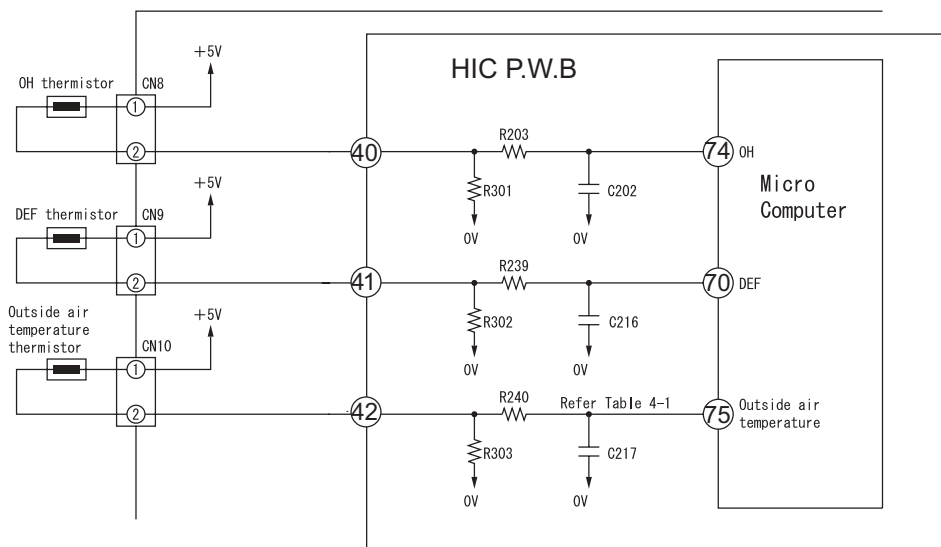


Fig.5-1

- OH thermistor circuit detect the temperature at the surface of compressor head, DEF thermistor circuit detect the defrosting operation temperature.
  - A thermistor is a negative resistor element which has characteristics that the higher(lower) the temperature, the lower(higher) the resistance.
  - When the compressor is heated, the resistance of the OH thermistor becomes low and  $\oplus 5V$  is divided by OH thermistor and R301 and the voltage at pin (74) of microcomputer.
  - Compare the voltage at microcomputer pin (74) and setting value stored inside. If the value exceed the set value, microcomputer will judge that the compressor is overheated and stop the operation.
  - When frost is formed on the outdoor heat exchanger, the temperature at the exchanger drops abruptly. Therefore the resistance of the DEF thermistor becomes high and the voltage at pin (70) of micro computer drops. If this voltage becomes lower than the set value stored inside, microcomputer will enter the defrost control.
  - During defrost operation, the microcomputer will transfer the defrosting condition command to indoor unit via SDO pin of interface of IF transmission output.
  - The microcomputer read the outdoor temperature by Outside Air thermistor and transfer it to the indoor unit, thus controlling the compressor rotation speed according to the set value in the EEPROM of indoor unit and switching the operation mode (outdoor fan on/off etc.) to DRY mode.
- Below table show the typical values of outdoor temperature in relation to the voltage.

Table 5-1

Outside Air Temperature (°C)	-10	0	10	20	30	40
Voltage at both side of R303 (V)	1.19	1.69	2.23	2.75	3.22	3.62

<Reference>

When the thermistor is open, open condition or disconnect, microcomputer pin(70)(74)(75) are approx. 0V;

When thermistor is shorted, they are approx. 5V and LD301 will blink 7 times.

However, an error is detected when only the OH thermistor is shorted and will enter blinking mode after 12 minutes start the compressor operation.

## 6. Electric expansion valve circuit

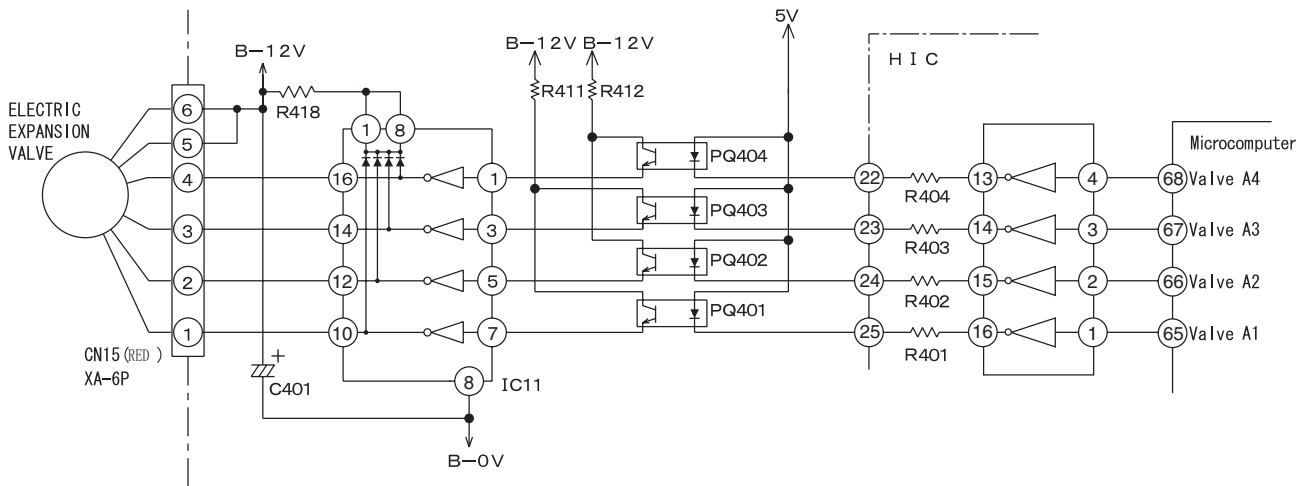


Fig. 6-1

- The electric expansion valve is driven by DC12V. Power is supplied to 1 or 2 phases of 4-phase winding to switch magnetic pole of winding in order to control the opening degree.
- Relationship between power switching direction of phase and open/close direction is shown below. When power is supplied, voltages at pins ④ to ① of CN15 are about 0.9V and 12V when no power is supplied. When power is reset, initial operation is performed for 10 or 20 seconds. During initial operation, measure all voltages at pin ④ to ① of CN15 by using a multimeter. If there is any pin with voltage that has not changed from 0.9V or 12V, expansion valve or microcomputer is broken.
- Fig. 6-2 shows logic waveform when expansion valve is operating.

Table 6-1

CN15 pin no.	Wire	Drive status							
		1	2	3	4	5	6	7	8
①	WHT	ON	ON	OFF	OFF	OFF	OFF	OFF	ON
②	YEL	OFF	ON	ON	ON	OFF	OFF	OFF	OFF
③	ORG	OFF	OFF	OFF	ON	ON	ON	OFF	OFF
④	BLU	OFF	OFF	OFF	OFF	OFF	ON	ON	ON

Operation mode  
 1→2→3→4→5→6→7→8 VALVE CLOSE  
 8→7→6→5→4→3→2→1 VALVE OPEN

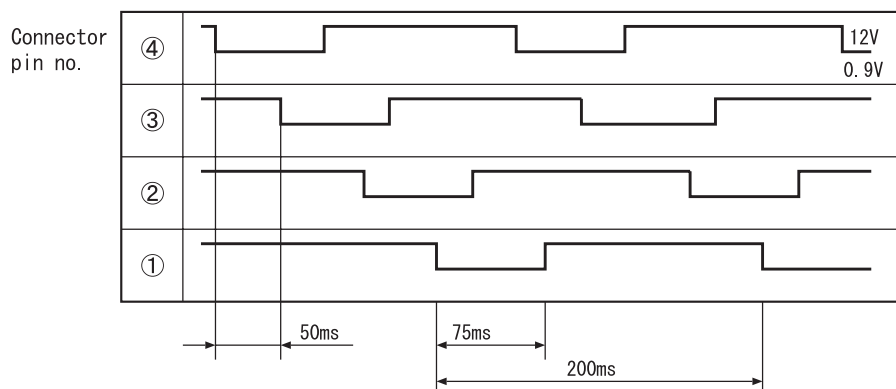


Fig. 6-2

With expansion valve control, opening degree is adjusted to stabilize target temperature by detecting compressor head temperature. The period of control is about once per 20 seconds and output a few pulse.

## 7. Outdoor DC fan motor control circuit

- This model is built with DC fan motor control circuit inside outdoor electrical unit.

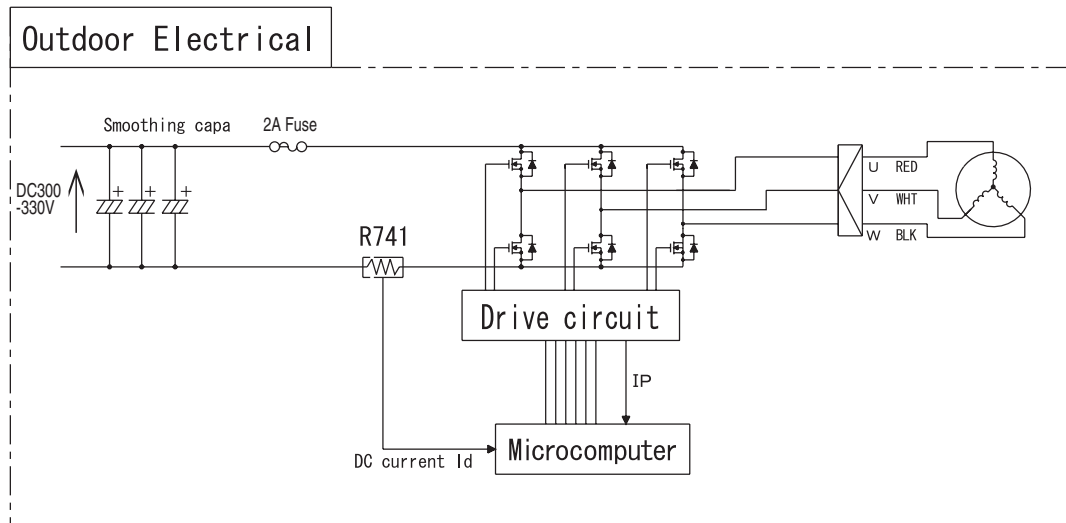


Fig 7-1

This DC fan motor is control by outdoor microcomputer that follow the operating instruction received from indoor microcomputer. The DC current that flow from R741 will presume actual operation speed and control the rotation to follow the operating instruction. Based on this DC current it will detect a over current and other fan motor failure.

### (1) Fan motor speed controller during starting

Due to the interference of strong wind etc., operation movement is changed based on fan direction and rotation speed as shown below during starting of operation.

In addition, the fair wind is define as wind that blow to outside direction using Mouth Ring part. At strong and contrary wind ... The rotational speed is not controlled as to protect the equipment and fan will rotate reversely depend on the wind. Automatically start when wind condition become weak.

At contrary wind ... The rotational speed is controlled in fair wind direction after it slowly reduce the speed and finally stop.

At fair wind ... The rotational speed is controlled as it is.

At strong fair wind ... The rotational speed is not controlled as to protect the equipment and fan will rotate reversely depend on the wind. Automatically start when wind condition become weak.

### (2) Fan motor speed controller during unit operating

There is a case where fan rpm is reducing during rotating caused by interference of strong wind. If this condition continue in long period, fan will stop rotating. (LD301 : 11 times blinking)  
The unit will restart according to control as per during start (1).

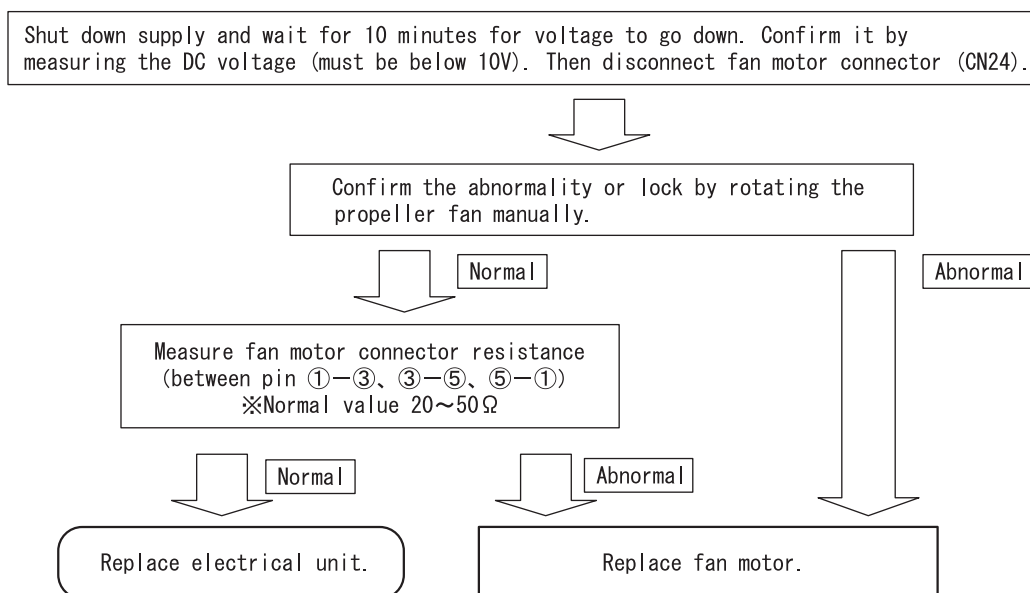


(3) Method of confirming self diagnosis LD301 lamp : 12 times blinking

If the unit stop and LD301 on the pwb blinking 12 times [fan lock stop is detected], follow below steps to confirm it.

1. Fan lock stop is detected when something has disturb the fan rotation by inserting material into propeller fan or ice has growing inside outdoor unit caused by snow.  
Remove it if found something is bloking the fan.
2. Confirmed that CN24 connector is securely inserted. Fan lock stop is detected also when connector is not properly inserted. Please securely insert if found any disconnection.
3. Fan lock stop also can be detected where strong wind blown surrounding the unit.  
Please confirm after restart the unit. (It may take few minutes to operate the compressor)  
It is not a malfunction of electrical unit or fan motor if the unit run continuesly after restart the unit.
4. Check fan motor condition as below procedure.

[Checking Fan Motor] procedure



5. Reconnect again fan motor connector (CN24).

※Please confirm above checking procedure if found 2A fuse blown.

If fan motor is broken, replace both electrical unit and fan motor.

Caution

※Beware of electric shock due to high voltage when conducting an operation check.

Power supply for DC fan motor and compressor is common (DC300-330V).

## SERVICE CALL Q&A

### Cooling operation

**Q1** The compressor sometimes stops during cooling.

**A1** Check if the heat exchanger of the indoor unit is covered with frost. Wait for 3 to 4 minutes until the frost disappears.

Cooling when the room temperature is low may cause the heat exchanger of the indoor unit to gather frost.

### Dehumidification

**Q1** The indoor unit produces a noise that goes "shaaahh" during dehumidification.

**A1** That is a noise produced by refrigerant flowing through the pipe.

**Q2** Cold air comes out during a dehumidifying operation.

**A2** To improve the dehumidification efficiency performs quiet fan operation. Therefore the air is cold and it is not a malfunction.

**Q3** The operation does not stop even by setting the temperature higher than room temperature on the remote controller.

**A3** It sets to perform dehumidifying operation by setting the temperature slightly lower than remote controller setting.

### Heating operation

**Q1** The product sometimes fails to produce a wind during heating.

**A1** Defrosting is in progress. Wait 5 to 10 minutes until the frost on the outdoor unit disappears.

**Q2** The product begins with a slight fan speed during heating even though set to "Hi fan" or "Med fan" or "Low fan" or "silent fan".

**A2** At the first of the heating, the product will run for 30 seconds with a slight fan speed. When set to strong fan speed, the product will begin with a slight fan speed operation, producing a weak fan speed for 30 seconds, and then switch to strong fan speed.

**Q3** The product stops during heating even though it is set to "30°C."

**A3** When heating is conducted despite the high outdoor temperature, the product may stop to protect its equipment.

### Auto-fresh defrost

**Q1** During heating, I turned off the product by using the START/STOP button. But the "operation lamp" is blinking and the outdoor unit is running.

**A1** The "auto-fresh defrost" should be working. When stopped, the product will check its outdoor unit for frost and, if there is any frost, conduct defrosting and then stop operating.

Common, etc.

**Q1** In "automatic fan speed" mode, the indoor fan changes from strong fan speed to weak fan speed to slight fan speed.



**A1** This does not abnormal. It is because the cold fan speed prevention is working.

In fan speed "automatic" mode, the product will sense the heat exchange temperature and, when the temperature goes down, the product will automatically switch to strong wind to weak fan speed to slight fan speed.

**Q2** At operation startup, the outdoor unit becomes noisy.



**A2** At operation startup, the product will set the rotation speed of the compressor to full power and increase its heating and cooling capacity, resulting in a slightly higher noise level. This is not a sign of a breakdown.

**Q3** The outdoor unit sometimes changes in its noise.



**A3** The difference between the thermometer temperature setting and room temperature will change the rotation speed of the compressor. This is not a sign of a breakdown.

**Q4** There is a difference between the temperature setting and room temperature in room temperature control.



**A4** The room structure, air stream, or other factor may cause a gap between the room temperature setting and actual room temperature. If there is any difference between the setting and the room temperature, adjust the temperature setting to match the living space to a comfortable temperature.

**Q5** The product will not produce wind right after startup.



**A5** After turning ON the power switch or breaker, setting the product to heating or dehumidification will activate a preliminary operation for 1 minute. At that time, heating will cause the operation lamp to blink. This is not a sign of a breakdown.

**Q6** I performed internal cleaning, but didn't succeed in controlling the mold in the room.



**A6** Internal cleaning will clean the inside of the indoor unit of the air-conditioner, thereby controlling mold generation. This will not control the mold in the room.

## Wireless remote control

**Q1** The timer will not become set.



**A1** Have you set the product to the current time? The timer cannot be set unless it is set to the current time.

**Q2** The current time display will disappear at once.



**A2** The current time disappears 10 seconds later. The timer set display is given priority.

When set to the current time setting, the reading blinks for about 3 minutes.

**Q3** I made a timer "reservation". But the time setting has disappeared.



**A3** Is the time not past the reserved time? The set time disappears when the current time reaches the reserved time.

**Q4** I tried to set the "sleep" timer while the ON timer is reserved. But it will not set itself to a desired time.



**A4** The time set in the "sleep" timer can be set with a time up to the time set with the ON timer. If the end time of the "sleep" timer is past the time set with the ON timer, you cannot make that setting.

**Q5** I set the "sleep" timer during operation. But  
 ① the indoor fan will not run (it will not produce wind)  
 ② wind intensity will not change.



**A5** ① This occurs when the room temperature and humidity have reached their settings during dehumidification and the air-conditioner is in a pause. The product will begin again to run within about 3 minutes.  
 ② The product will run with the wind speed set to a "quiet" state.

**Q6** I tried to change the setting with the "room temperature" button of the remote control unit in vain.



**A6** You cannot make this setting when the product is in "air purification" mode. Moreover, you cannot set the product to a desired setting when quick laundry or dew control is being performed with the "auto" or "quick dehumidification" button.

**Q7** The temperature setting field on the remote control unit displays  $+f^{\circ}\text{C}$  or  $-f^{\circ}\text{C}$ .



**A7** The product will give a display when you operate the product in "auto" using the operation switch button. This can be controlled within the range of  $\pm 3^{\circ}\text{C}$ .  
 The product will display  $+f^{\circ}\text{C}$  if the temperature is  $f^{\circ}\text{C}$  higher than the room temperature in automatic setting.  
 The product will display  $-f^{\circ}\text{C}$  if the temperature is  $f^{\circ}\text{C}$  lower than the room temperature in automatic setting.

**Q8** The remote control unit will give no display in response to a push of the "vertical vane" button.



**A8** The remote control unit displays nothing.

**TROUBLE SHOOTING**  
**MODEL RAC-18/25/35/50WED**

**Inspection instructions**



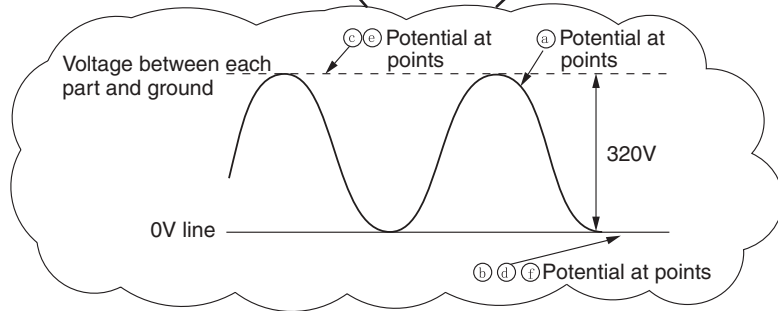
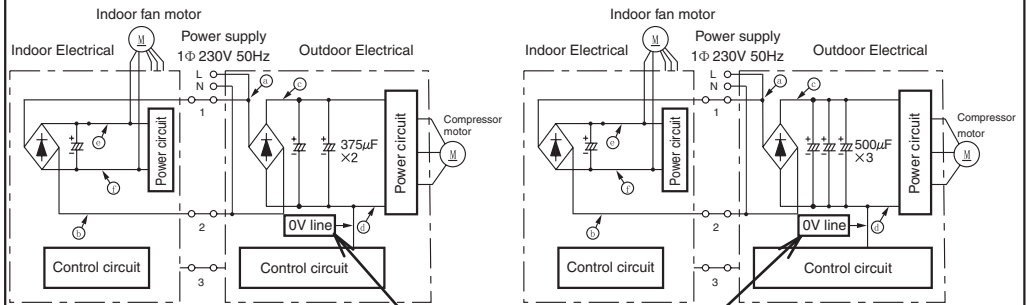
**Warning**

Note that the 0 V line of the outdoor electrical parts and the primary power circuit of the indoor electrical parts have voltages to ground as illustrated in the right-hand figure.



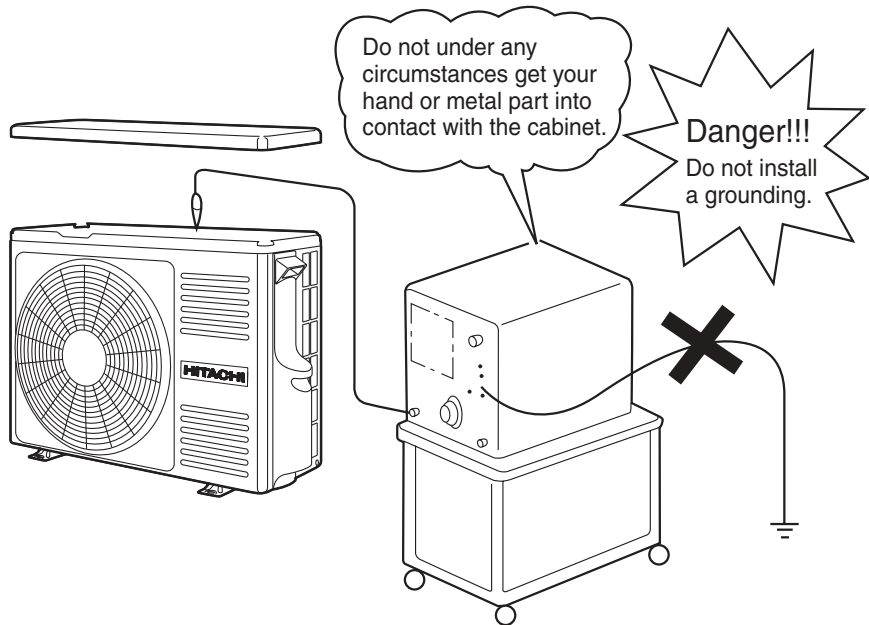
**RAC-18/25/35WED**

**RAC-50WED**



**Warning**

When conducting a check with an oscilloscope or something similar, do not ground the oscilloscope. Note that the oscilloscope will be subjected to voltages as illustrated in the figure above.



# DISCHARGE, PROCEDURE AND POWER SHUT OFF METHOD FOR POWER CIRCUIT



**WARNING**



## Caution

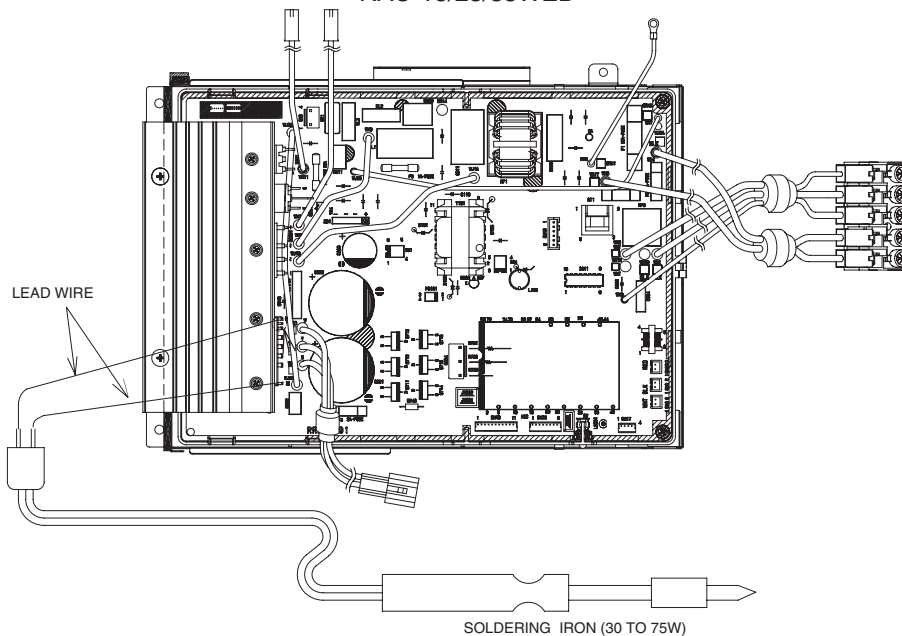
- Voltage of about 350 V is charged between the terminal of smoothing capacitors.
- During continuity check for each circuit part of the outdoor unit, be sure to discharge the smoothing capacitors.

## Discharge Procedure

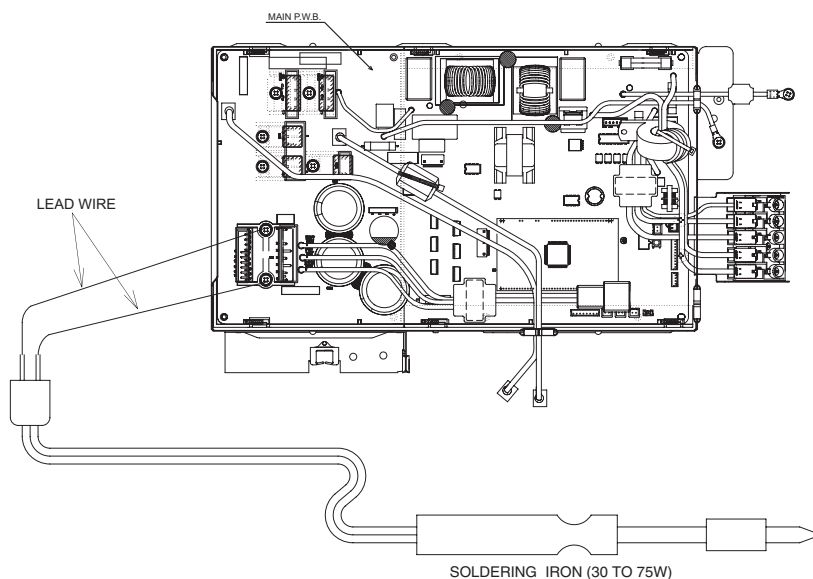
1. Turn off the power.
2. After power is turned off, wait for 10 minutes or more. Then, remove electrical parts cover and apply soldering iron of 30 to 75 W for 15 seconds or more to IPM(24) and IPM(20) terminals on the main P.W.B. as shown in the figure below, in order to discharge voltage in smoothing capacitor.

Do not use a soldering iron with transformer: Otherwise, thermal fuse inside transformer will be blown.

RAC-18/25/35WED



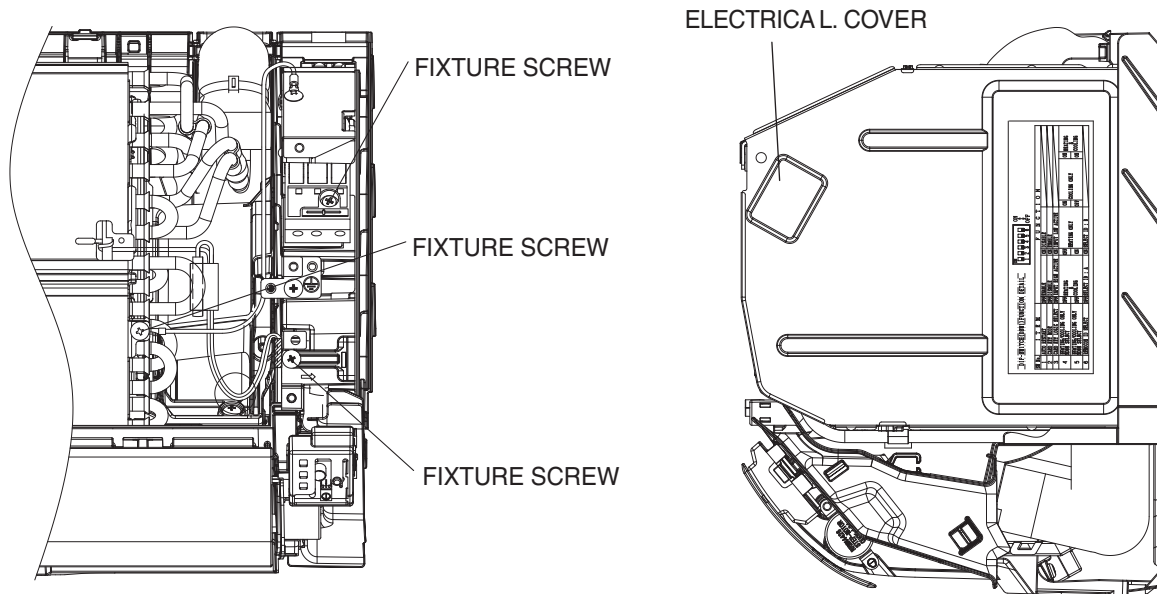
RAC-50WED



# STRUCTURE OF AN INDOOR UNIT ELECTRIC PARTS

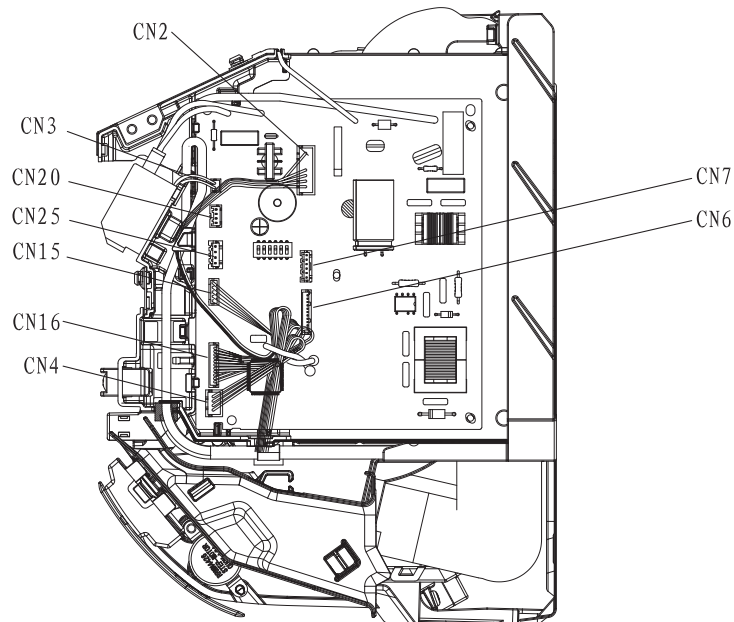
## RAK-18/25/35/50PED

## RAK-25/35/50PEDC



### Removing electrical parts

1. Remove the electrical parts cover.
2. Remove the connectors from the CN4 (heat exchange thermistor), CN15 (stepping motor) and CN2 (fan motor).
3. Remove three lock screws.



### Removing control P.W.B.

1. Remove the connectors from the CN3.
2. Remove the P.W.B. from the P.W.B. support.

### Removing the indicating P.W.B.

1. Remove the connector from the CN16 on the control P.W.B.
2. Remove the upper hook from the indicating P.W.B. lock resin, pull the P.W.B. forward a little and remove it.

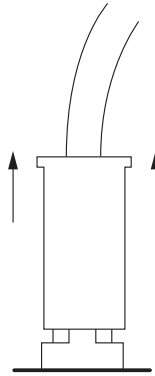
## Other instructions

### (1) Detaching and reattaching the receptacles for tab terminal

All the receptacles for connecting tab terminals are with a locking mechanism. Forcibly pulling any such receptacle without unlocking it will destroy it. Be on guard.

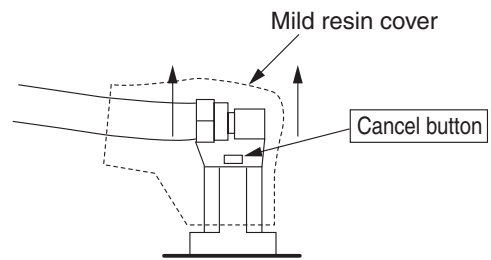
When reconnecting it, insert it securely all the way home.

#### · Receptacle types and how to unlock them



Vertical (with a resin case)

Hold the resin case and pull it out.



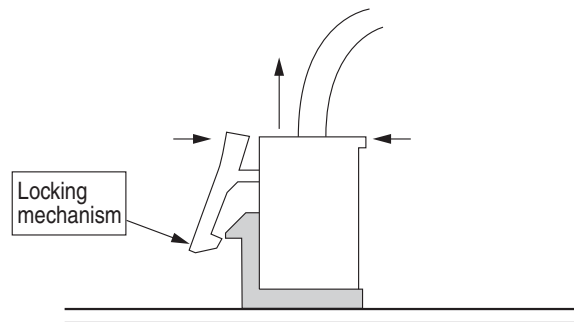
Horizontal (with a mild resin cover)

Hold the cancel button down on the mild resin cover while pulling it out.

### (2) Detaching and reattaching the board connector

The product comes equipped with many board connectors provided with lock mechanism. Forcibly pulling any such part without unlocking it will destroy it. Be on guard. When reconnecting it, insert it securely all the way home.

Pinch the locking mechanism with your fingers and pull it out unlocked.



### (3) Do not detach or reattach the connectors while energized

Do not under any circumstances detach or reattach the connectors while energized. That would destroy the board components and fan motor. For both the indoor and outdoor boards, ensure that the smoothing capacitor has discharged its electricity fully before you do your work.



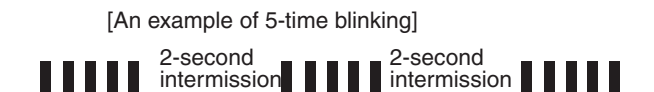
No	Function	Description
1	Self-diagnosis display [Display on the indoor unit side]	<ul style="list-style-type: none"> <li>The failure mode detected on the indoor unit side is displayed by blinking the "timer lamp". And a failure detected on the outdoor unit side will be indicated by the "time lamp" blinking 4 times.</li> <li>If the outdoor unit side detects a failure, the product will first conduct several operation retrials.</li> </ul> <p>There are some failure modes with no lamp display while retrials are continued.</p> <p>[Failure mode where retrials are continued and the indoor unit lamp does not end up giving a display]</p> <ul style="list-style-type: none"> <li>OH thermistor heat-up</li> <li>Overload lower limit cut</li> <li>Low-frequency things</li> </ul>
	[Display on the outdoor unit side]	<ul style="list-style-type: none"> <li>The failure mode detected on the outdoor unit side is displayed by blinking the "LD301". Detecting a failure will stop the outdoor unit and keep blinking the LD301 until it is restarted.</li> </ul> <p>(The communication error will persist until the communication is reestablished.)</p>
2	Self-diagnosis memory	<ul style="list-style-type: none"> <li>The failure modes detected on the indoor and outdoor unit sides are stored in the nonvolatile memory of the indoor unit and can be read later on.</li> <li>(The memory will remain even after power-off.)</li> <li>The failure modes detected on the outdoor unit side are written in memory every time any such mode occurs. The failure mode can therefore be detected on the indoor unit side without waiting for the retry frequency to reach the display of the indoor unit lamp. Moreover, the normal self-diagnosis display function which rarely occurs will store and display failure modes that do not end up displaying the indoor unit lamp.</li> <li>(Any such mode may be unable to be stored if indoor or outdoor communications is in a failure.)</li> <li>The product stores 5 last-stored failure modes.</li> <li>There is a function for deleting memory. Once you clear the memory and run the product for several days, you can read the failure modes and check them, thereby detecting the less frequent failure phenomena.</li> <li>Failure modes can be checked by both the blinking of the lamp of the indoor unit and the display of the remote control liquid crystal display.</li> </ul>

※The "self-diagnosis function of the communication circuit" available in our conventional models is now incorporated as part of the normal self-diagnosis function. In the case of a failure in the communication circuit, you do not have to conduct a special operation and the operations can be automatically divided into 3 blinking operations and 12 blinking operations of the timer lamp. However, a strong external noise may have resulted in 12 times of blinking.

## Self-diagnosis display function (indoor side display)

While the "timer lamp" (orange), of the indoor unit is blinking, troubleshoot the product while referring to the table below.

- How to count the lamp blinking frequency
  - The product will repeat blinking with 2-second intermissions.
  - The blinking speed is as follows: on for 0.35 seconds and off for 0.35 seconds.



- If you wish to try another operation while the lamp is blinking, operate the START/STOP button on the remote control unit twice. The first push will reset the indoor microcomputer, while the second will activate the product

## DESCRIPTION OF THE SELF-DIAGNOSIS INDICATION

REFER TO THE TABLE BELOW IF THE TIMER INDICATOR (ORANGE) IS BLINKING.

LAMP BLINKING MODE	MAIN DEFECTIVE
■ 2 sec ■ — — — — ONCE	REFRIGERANT CYCLE DEFECTIVE
■ ■ 2 sec ■ — — — — 2 TIMES	FORCED COOLING OPERATION
■ ■ ■ 2 sec ■ — — — 3 TIMES	INTERFACE DEFECTIVE (INDOOR)
■ ■ ■ 2 sec ■ — — — 4 TIMES	OUTDOOR UNIT DEFECTIVE
■ ■ ≪ ■ ■ 2 sec ■ — 9 TIMES	INDOOR THERMISTOR DEFECTIVE
■ ■ ≪ ■ ■ 2 sec ■ — 10 TIMES	ABNORMAL ROTATING NUMBERS OF DC FAN MOTOR
■ ■ ≪ ■ ■ 2 sec ■ — 12 TIMES	INTERFACE DEFECTIVE (OUTDOOR)
■ ■ ≪ ■ ■ 2 sec ■ — 13 TIMES	IC531 DEFECTIVE

( ■ — — LIGHTS FOR 0.35 SEC AT INTERVAL OF 0.35 SEC. )

\* IF THE INTERFACE CIRCUIT IS DEFECTIVE WHEN THE POWER IS TURNED ON.

THE SELF-DIAGNOSIS INDICATION WILL NOT WORK.

\* IF THE INDOOR UNIT CAN NOT BE OPERATED AT ALL,

REFER TO THE TABLE BELOW IF THE INDOOR UNIT DOES NOT WORK AT ALL.

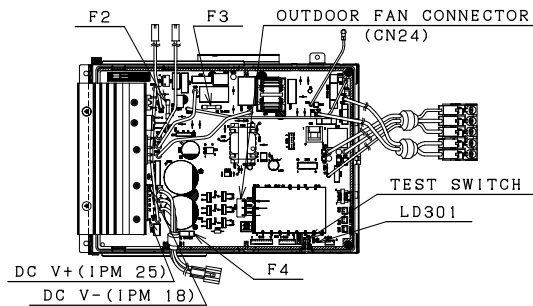
CHECK POINT	ACTION/REPLACEMENT PARTS, etc
FU1 (3.15A) FUSE BLOWN	REPLACE THE PART WHICH CAUSED BLOWING /DISCONNECTION OF FU1 (3.15A) FUSE
COME OFF OR DISCONNECTION OF THE CONNECTOR FOR INDICATING P.W.B	FIX CN16 CONNECTOR
FAILURE OF CONTROL P.W.B	REFER TO THE SERVICE GUIDE FOR HOW TO DETERMINE THE FAILED PART

# SELF-DIAGNOSIS LIGHTING MODE

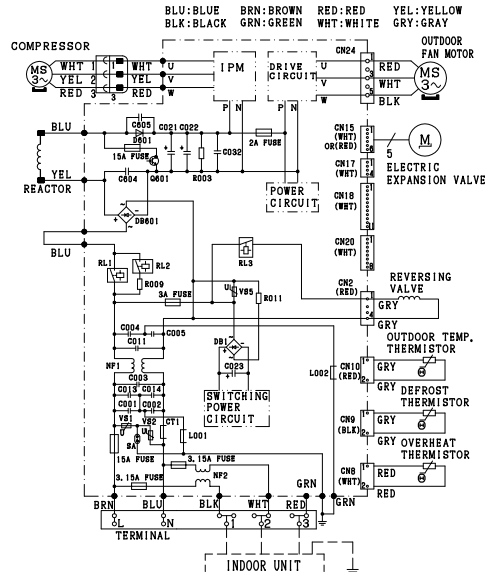
MODEL RAC-18/25/35WED

**⚠ DANGER (DC350V)**

- CUT THE POWER SOURCE AND WAIT MORE THAN 10 MINUTES BEFORE SERVICE WORK.
- CONFIRM THE DC VOLTAGE AT THE MEASURING POINT SHOWN IN BELOW FIGURE MUST BE LESS THAN 10V.



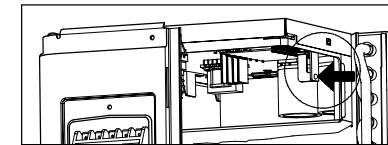
## WIRING DIAGRAM



DURING STOP			
SELF-DIAGNOSIS BLINKING MODE			
		▣:BLINK	□:OFF
LD301 (RED)	SELF DIAGNOSIS CONTENTS	MAIN CHECK POINT	HOW TO REPAIR
□ OFF	NORMAL STOP (STOPPED BY INDOOR THERMISTAT OR MAIN OPERATION OFF)	1. NO NEED TO CHECK	1. NOT ANY MALFUNCTION
▣ ONCE	RESET STOP	1. MICROPROCESSOR WAS REBOOTED	1. CHANGE ODU CONTROLLER
▣ 2 TIMES	PEAK CURRENT CUT	1. ODU CONTROLLER DEFECTIVE 2. COMPRESSOR ABNORMAL LOAD	1. CHANGE ODU CONTROLLER 2. CHECK THE COMPRESSOR
▣ 3 TIMES	ABNORMAL LOW SPEED ROTATION	1. ODU CONTROLLER DEFECTIVE 2. COMPRESSOR ABNORMAL LOAD	1. CHANGE ODU CONTROLLER 2. CHECK THE COMPRESSOR
▣ 4 TIMES	SWITCHING FAILURE	1. COMPRESSOR CONNECTOR OPEN 2. COMPRESSOR ABNORMAL LOAD 3. ODU CONTROLLER DEFECTIVE	1. INSERT THE CONNECTOR 2. CHECK THE COMPRESSOR 3. CHANGE ODU CONTROLLER
▣ 5 TIMES	OVERLOAD LOWER LIMIT CUT	1. OBSTACLE SURROUND THE ODU MAY CAUSE 2. OTHER CAUSE	1. REMOVE THE OBSTRUCTION 2. CHECK CYCLE PIPE
▣ 6 TIMES	OH THERMISTOR TEMPERATURE RISE	1. DUE TO OPEN CONNECTOR 2. LEAKAGE OF REFRIGERANT 3. OTHER CAUSE	1. INSERT THE CONNECTOR 2. CHECK THE CYCLE PIPE AND RECHARGE THE REFRIGERANT 3. CHANGE ODU CONTROLLER
▣ 7 TIMES	THERMISTOR ABNORMAL	1. CONNECTOR INSERT MISS 2. OPEN CIRCUIT/SHORT CIRCUIT OF THERMISTOR WIRE 3. ODU CONTROLLER DEFECTIVE	1. INSERT PROPERLY 2. CHANGE THE THERMISTOR 3. CHANGE ODU CONTROLLER
▣ 9 TIMES	COMMUNICATIONS ERROR	1. F CABLE MISS CONNECTION 2. F CABLE DISCONNECTION 3. ODU CONTROLLER DEFECTIVE 4. IDU CONTROLLER DEFECTIVE	1. F CABLE CONNECT PROPERLY 2. CHANGE THE F CABLE 3. CHANGE ODU CONTROLLER 4. CHANGE IDU CONTROLLER
▣ 10 TIMES	ABNORMAL POWER SOURCE	1. REACTOR IS UNCONNECTED 2. ABNORMAL AC INPUT: OUT OF THE RANGE (230±10%) 3. AC INPUT IS NORMAL	1. CONNECT REACTOR PROPERLY 2. CONNECT TO NORMAL AC POWER SOURCE 3. CHANGE ODU CONTROLLER
▣ 11 TIMES	ODU FAN STOP BY STRONG REVERSE WIND	1. OUTDOOR FAN STOP BY STRONG REVERSE WIND	1. IT WILL RE-START AFTER THE WIND BECOME WEAK
▣ 12 TIMES	OUTDOOR FAN LOCK ERROR	1. OUTDOOR FAN STOP BY STRONG REVERSE WIND 2. PROPELLER FAN LOCK 3. OUTDOOR FAN MOTOR LOCK 4. OUTDOOR FAN MOTOR OK	1. AUTOMATICALLY RE-START AFTER WIND BECOME WEAK 2. REMOVE THE OBSTRUCTION 3. CHANGE THE FAN MOTOR 4. CHANGE ODU CONTROLLER
▣ 13 TIMES	EEPROM READ ERROR	• CHANGE OUTDOOR UNIT CONTROLLER	
▣ 14 TIMES	ACTIVE VOLTAGE ABNORMAL	1. ABNORMAL OUTDOOR CONTROLLER 2. ABNORMAL COMPRESSOR LOAD	1. CHANGE ODU CONTROLLER 2. CHECK THE COMPRESSOR
▣ 15 TIMES	CIRCUIT ABNORMAL	• CHANGE OUTDOOR UNIT CONTROLLER	
▣ 16 TIMES	HIGH LORD STOP	1. SERVICE VALVE CLOSE 2. OBSTACLE SURROUND THE ODU MAY CAUSE 3. CLOGGED FILTER IN INDOOR UNIT CAUSE.	1. CHECK SERVICE VALVE 2. REMOVE THE OBSTRUCTION 3. CHECK FILTER



RIGHT SIDE ARROW INDICATE THE POSITION OF TEST SWITCH LEVER ON THE SIDE PANEL (SHOWN IN UNDER FIGURE.)



DURING STOP	
LD301 LIGHT	CONTENTS
2 SEC LIGHTING AND 0.3 SEC LIGHTS OUT REPETITION	NORMAL OPERATION OVERLOAD OPERATION (NORMAL OPERATION)

\*ODU=OUTDOOR UNIT, IDU=INDOOR UNIT

## \*OTHERS CHECK POINTS

1. DIAGNOSIS FOR [REVERSING VALVE OPERATION ERROR] ;  
⇒CHECK REVERSING VALVE WIRE CONNECTION EITHER WIRE BROKEN OR NOT, IF OK CHECK 3.15A FUSE, IF BROKEN REPLACE FUSE OR ODU CONTROLLER.
2. [WHEN DISPLAY THE COMMUNICATION ERROR OR THE OUTDOOR DO NOT RUN AT ALL].  
⇒PLEASE CHECK THE CONTINUITY OF THE INDOOR ↔ OUTDOOR CONNECTING CORD(F CABLE).

## [OUTDOOR FAN MOTOR CHECK]DIAGNOSIS METHOD

1. PUT THE POWER OFF
  2. REMOVE THE OUTDOOR FAN MOTOR'S CONNECTOR FROM 'CN24'
  3. ROTATE THE FAN MOTOR BY HAND AND CHECK WHETHER THE FAN MOTOR IS LOCKED OR NOT.
  4. MEASURE THE RESISTANCE BETWEEN EACH TERMINAL OF THE FAN MOTOR CONNECTOR. NORMAL RESISTANCE BETWEEN EACH TERMINAL REFER TO THE SERVICE MANUAL.
- \*INSERT THE FAN MOTOR'S CONNECTOR AFTER FINISHING STEPS 1 TO 4.

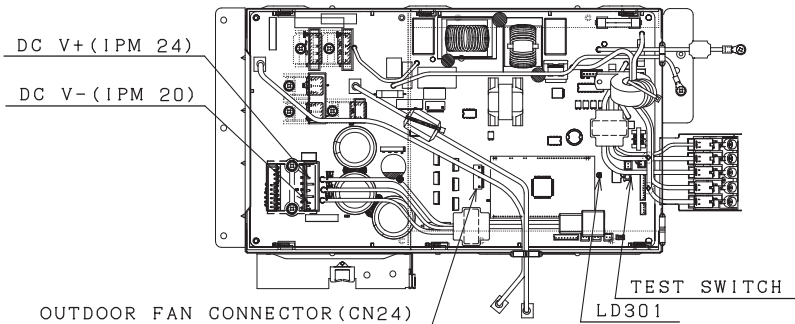
\*OTHERS SELF-DIAGNOSIS CONTENTS REFER TO THE SERVICE MANUAL.

# SELF-DIAGNOSIS LIGHTING MODE

MODEL RAC-50WED

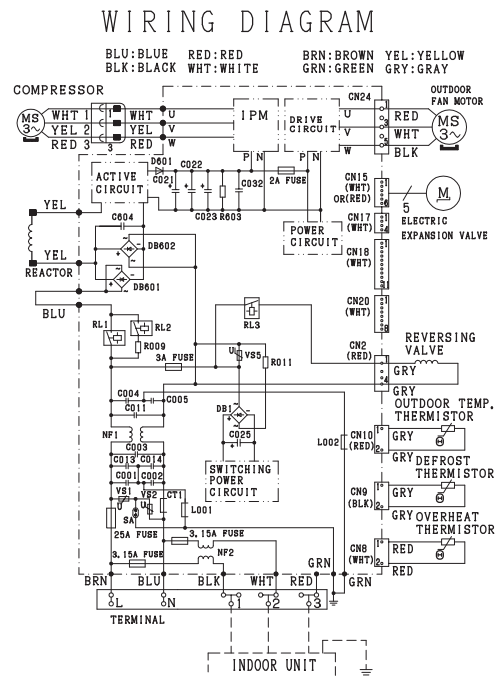
**⚠️ ⚡ DANGER (DC350V)**

- CUT THE POWER SOURCE AND WAIT MORE THAN 10 MINUTES BEFORE SERVICE WORK.
- CONFIRM THE DC VOLTAGE AT THE MEASURING POINT SHOWN IN BELOW FIGURE MUST BE LESS THAN 10V.



DURING STOP	
LD301	CONTENTS
LIGHT	NORMAL OPERATION
2 SEC LIGHTING AND 0.3 SEC LIGHTS OUT REPETITION	OVERLOAD OPERATION(NORMAL OPERATION)

DURING STOP			
SELF-DIAGNOSIS BLINKING MODE			
		▣:BLINK	□:OFF
LD301 (RED)	SELF DIAGNOSIS CONTENTS	MAIN CHECK POINT	HOW TO REPAIR
□	OFF	1. NO NEED TO CHECK	1. NOT ANY MALFUNCTION
▣	ONCE	1. MICROPROCESSOR WAS REBOOTED	1. CHANGE ODU CONTROLLER
▣	2 TIMES	1. ODU CONTROLLER DEFECTIVE 2. COMPRESSOR ABNORMAL LOAD	1. CHANGE ODU CONTROLLER 2. CHECK THE COMPRESSOR
▣	3 TIMES	1. ODU CONTROLLER DEFECTIVE 2. COMPRESSOR ABNORMAL LOAD	1. CHANGE ODU CONTROLLER 2. CHECK THE COMPRESSOR
▣	4 TIMES	1. COMPRESSOR CONNECTOR OPEN 2. COMPRESSOR ABNORMAL LOAD 3. ODU CONTROLLER DEFECTIVE	1. INSERT THE CONNECTOR 2. CHECK THE COMPRESSOR 3. CHANGE ODU CONTROLLER
▣	5 TIMES	1. OBSTACLE SURROUND THE ODU MAY CAUSE 2. OTHER CAUSE	1. REMOVE THE OBSTRUCTION 2. CHECK CYCLE PIPE
▣	6 TIMES	1. DUE TO OPEN CONNECTOR 2. LEAKAGE OF REFRIGERANT 3. OTHER CAUSE	1. INSERT THE CONNECTOR 2. CHECK THE CYCLE PIPE AND RECHARGE THE REFRIGERANT 3. CHANGE ODU CONTROLLER
▣	7 TIMES	1. CONNECTOR INSERT MISS 2. OPEN CIRCUIT/SHORT CIRCUIT OF THERMISTOR WIRE 3. ODU CONTROLLER DEFECTIVE	1. INSERT PROPERLY 2. CHANGE THE THERMISTOR 3. CHANGE ODU CONTROLLER
▣	9 TIMES	1. F CABLE MISS CONNECTION 2. F CABLE DISCONNECTION 3. ODU CONTROLLER DEFECTIVE 4. IDU CONTROLLER DEFECTIVE	1. F CABLE CONNECT PROPERLY 2. CHANGE THE F CABLE 3. CHANGE ODU CONTROLLER 4. CHANGE IDU CONTROLLER
▣	10 TIMES	1. REACTOR IS UNCONNECTED 2. ABNORMAL AC INPUT: OUT OF THE RANGE (230±10%) 3. AC INPUT IS NORMAL	1. CONNECT REACTOR PROPERLY 2. CONNECT TO NORMAL AC POWER SOURCE 3. CHANGE ODU CONTROLLER
▣	11 TIMES	1. OUTDOOR FAN STOP BY STRONG REVERSE WIND	1. IT WILL RE-START AFTER THE WIND BECOME WEAK
▣	12 TIMES	1. OUTDOOR FAN STOP BY STRONG REVERSE WIND 2. PROPELLER FAN LOCK 3. OUTDOOR FAN MOTOR LOCK 4. OUTDOOR FAN MOTOR OK	1. AUTOMATICALLY RE-START AFTER WIND BECOME WEAK 2. REMOVE THE OBSTRUCTION 3. CHANGE THE FAN MOTOR 4. CHANGE ODU CONTROLLER
▣	13 TIMES	EEPROM READ ERROR	•CHANGE OUTDOOR UNIT CONTROLLER
▣	14 TIMES	ACTIVE VOLTAGE ABNORMAL	1. ABNORMAL OUTDOOR 2. ABNORMAL COMPRESSOR LOAD
▣	15 TIMES	CIRCUIT ABNORMAL	•CHANGE OUTDOOR UNIT CONTROLLER
▣	16 TIMES	HIGH LOAD STOP	1. SERVICE VALVE CLOSE 2. OBSTACLE SURROUND THE ODU MAY CAUSE 3. CLOGGED FILTER IN INDOOR UNIT CAUSE.



- \*ODU=OUTDOOR UNIT, IDU=INDOOR UNIT
- [OUTDOOR FAN MOTOR CHECK] DIAGNOSIS METHOD**
1. PUT THE POWER OFF.
  2. REMOVE THE OUTDOOR FAN MOTOR'S CONNECTOR FROM "CN24".
  3. ROTATE THE FAN MOTOR BY HAND AND CHECK WHETHER THE FAN MOTOR IS LOCKED OR NOT.
  4. MEASURE THE RESISTANCE BETWEEN EACH TERMINAL OF THE FAN MOTOR CONNECTOR. NORMAL RESISTANCE BETWEEN EACH TERMINAL REFER TO THE SERVICE MANUAL.
- \*INSERT THE FAN MOTOR'S CONNECTOR AFTER FINISHING STEPS 1 TO 4.
- \*OTHERS CHECK POINTS**
1. DIAGNOSIS FOR [REVERSING VALVE OPERATION ERROR] ;  
⇒CHECK REVERSING VALVE WIRE CONNECTION EITHER WIRE BROKEN OR NOT, IF OK CHECK 3, 15A FUSE, IF BROKEN REPLACE FUSE OR ODU CONTROLLER.
  2. [WHEN DISPLAY THE COMMUNICATION ERROR OR THE OUTDOOR DO NOT RUN AT ALL].  
⇒PLEASE CHECK THE CONTINUITY OF THE INDOOR ↔ OUTDOOR CONNECTING CORD(F CABLE).
- \*OTHERS SELF-DIAGNOSIS CONTENTS REFER TO THE SERVICE MANUAL.

## Forced cooling operation

The cooling operation can be forcibly performed for collecting refrigerant and inspecting failures. Do not perform the forced cooling operation continuously for long hours, because the compressor continues to be in operational status, regardless of room temperature.

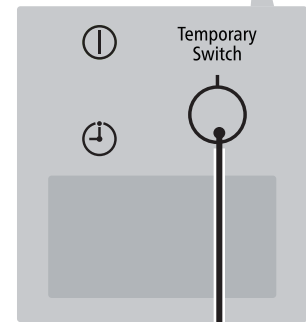
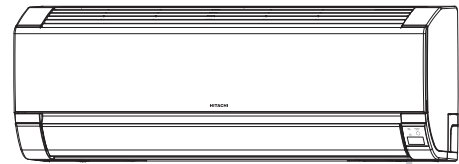
<How to start the operation>

- The operation of the unit should be stopped.
- Press and hold the "Temporary operation SW" shown in the right figure for 5 sec.

<How to stop the operation>

- Press and hold the "Temporary operation SW" again. Or stop the operation using the remote controller.

※During the forced cooling operation, the "Timer indicator" blinks twice.

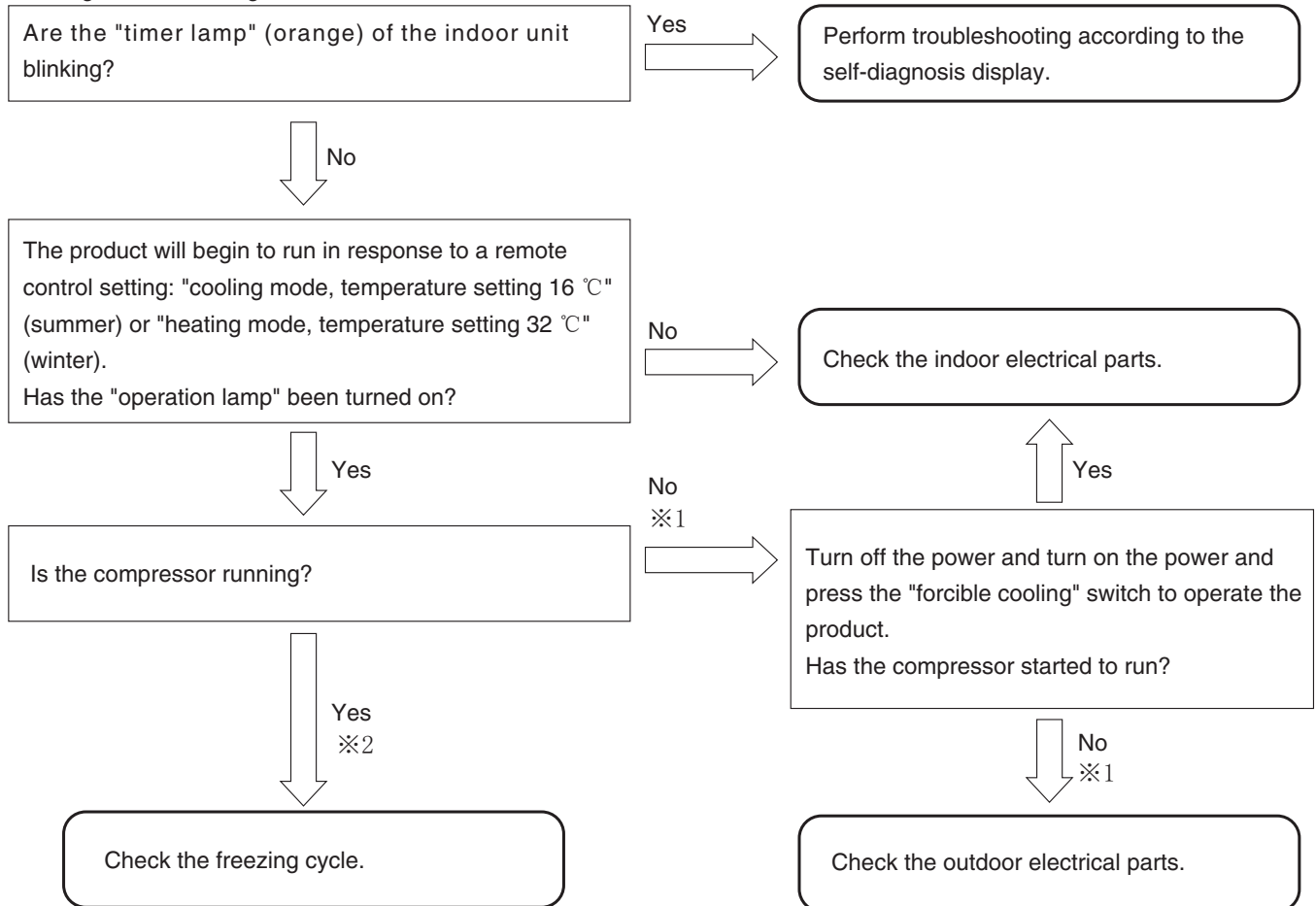


### Temporary operation switch

When performing the forced cooling operation, turn the power off once. If you press and hold the switch for 5 sec or longer, the forced cooling operation starts. To stop the forced cooling operation, press the switch once again or stop the operation using the remote controller.

## Diagnosis and troubleshooting of indoor electric parts, outdoor electric parts and refrigerating cycle

### Initiating troubleshooting



### < Troubleshooting by using the self-diagnosis memory function >

- By using the self-diagnosis memory function, you can check the failure mode (※1) occurring in the outdoor electrical parts on the indoor unit side.

- Steps
1. Clear the troubleshooting data.
  2. Run the product for several minutes under the conditions where the compressor runs.
  3. Redisplay and check the data written in the self-diagnosis memory.

- The self-diagnosis memory function can also be used to catch sporadic failure phenomena.

- Steps
1. Clear the troubleshooting data.
  2. Have the user use the product as usual until a failure phenomenon occurs.  
(The period depends on the incidence of the phenomenon.)
  3. At a later date, redisplay and check the data written in the self-diagnosis memory.

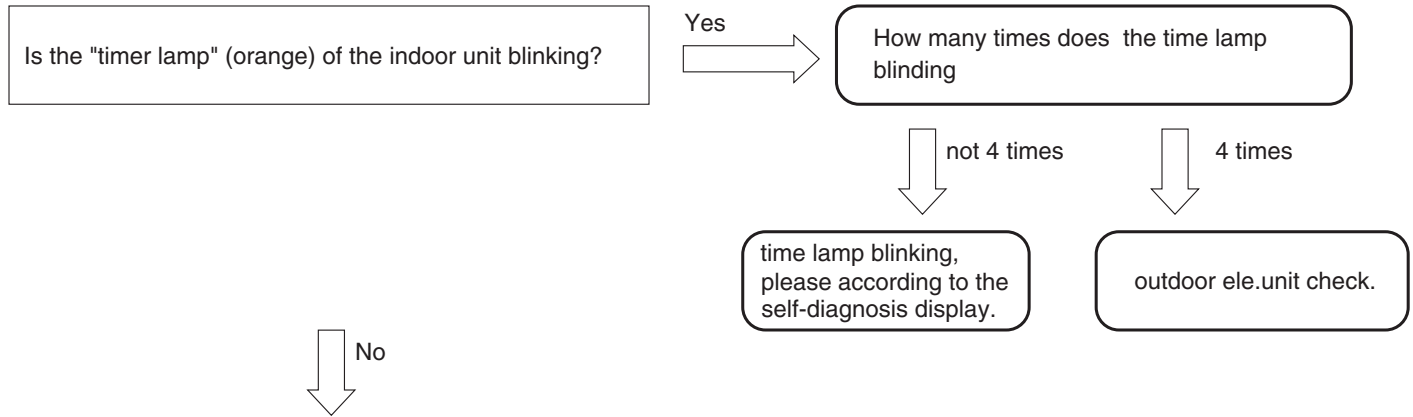
- For the outdoor self-diagnosis display (OH thermistor heat-up, overload lower limit cut) stemming from the freezing cycle or operating condition, the time lag is long from operation startup to the emergence of the phenomenon. Moreover, it is affected by the temperature, sunshine, operating hours, and other factors of the day, so that the phenomenon may not be able to be identified at the time of a repair service visit. In that case too, use the self-diagnosis memory function (※2).
- The outdoor self-diagnosis display "overload lower limit cut" and "OH thermistor heat-up" can be identified only when you are using the self-diagnosis lamp of the outdoor unit and the self-diagnosis memory function of the indoor unit. Note that this will not be automatically displayed on the indoor unit side.

## Checking the indoor unit electrical parts

### Introduction

First check the failure phenomenon and status, and then move on to elaborate diagnosis.

#### Initiating troubleshooting



Turn off the power, wait at least 5 seconds, turn it back on, and observe the way the horizontal vanes move for about 30 seconds.

Check 1: Have the horizontal vanes moved? (Yes/No)



Set the remote control unit to cooling mode, temperature setting 16°C (summer), heating mode, temperature setting 32°C (winter) and operate the product.

Check 2: Has the product received the remote control signal and has the "operation lamp" gone on? (Yes/No)

If you responded "Yes" to Check 2:

Check 3: Is the compressor of the outdoor unit running? (Yes/No)

If you responded "No" to Check 2:

Check 4: Does the "emergency operation switch" work? (Yes/No)

#### Check results and next check items

Check 1	Check 2	Check 3	Check 4	Next check item
No	No	—	No	Go on to "The power will not become turned on".
Yes	No	—	Yes	Go on to "The product will not receive the remote control signal".
Yes	Yes	No	—	Go on to "The compressor will not run".

# 1. Failure phenomenon: The power will not become turned on.

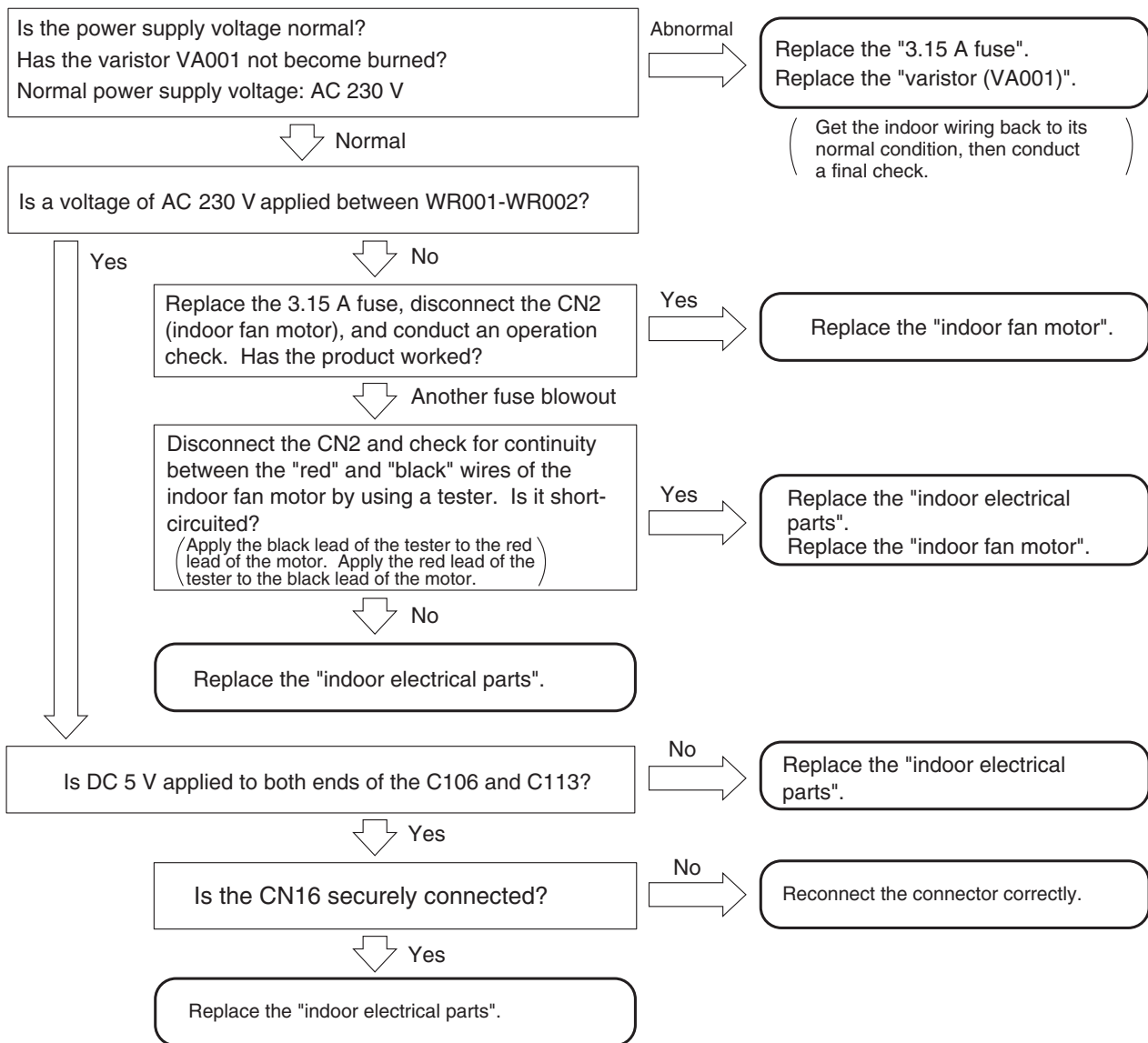
[Situation ] Neither initialization, remote control, nor any other step works on the vane position at power-on.

<p>[ Estimated failure locations ]</p> <ul style="list-style-type: none"> <li>· 3.15 A fuse blown out</li> <li>· Control power circuit</li> <li>· Connector loose, wire break</li> </ul>	<p>Estimated cause of fuse blowout</p> <ul style="list-style-type: none"> <li>· Abnormally high voltage applied to the power supply</li> <li>· Indoor fan motor out of order</li> <li>· Power circuit out of order</li> </ul>
--	---

- [Cautions ]
- Before work, check the power supply voltage. An abnormal voltage may be being supplied in some rare occasions due to a defect in the indoor wiring (a wire break in the neutral wire of the single-phase 3-wire power supply).
  - If the 3.15 A fuse has blown out, eliminate the cause of the fuse blowout. Otherwise, there will occur another fuse blowout.
  - If the 3.15 A fuse has blown out due to an abnormally high voltage to the power supply, the varistor (VA001) will deteriorate and become destroyed as well.
  - On a repair service visit due to the failure phenomenon of "The power will not become turned on", take a "3.15 A fuse" and a "varistor" with you.

## [Diagnosis flow ]

### Initiating troubleshooting



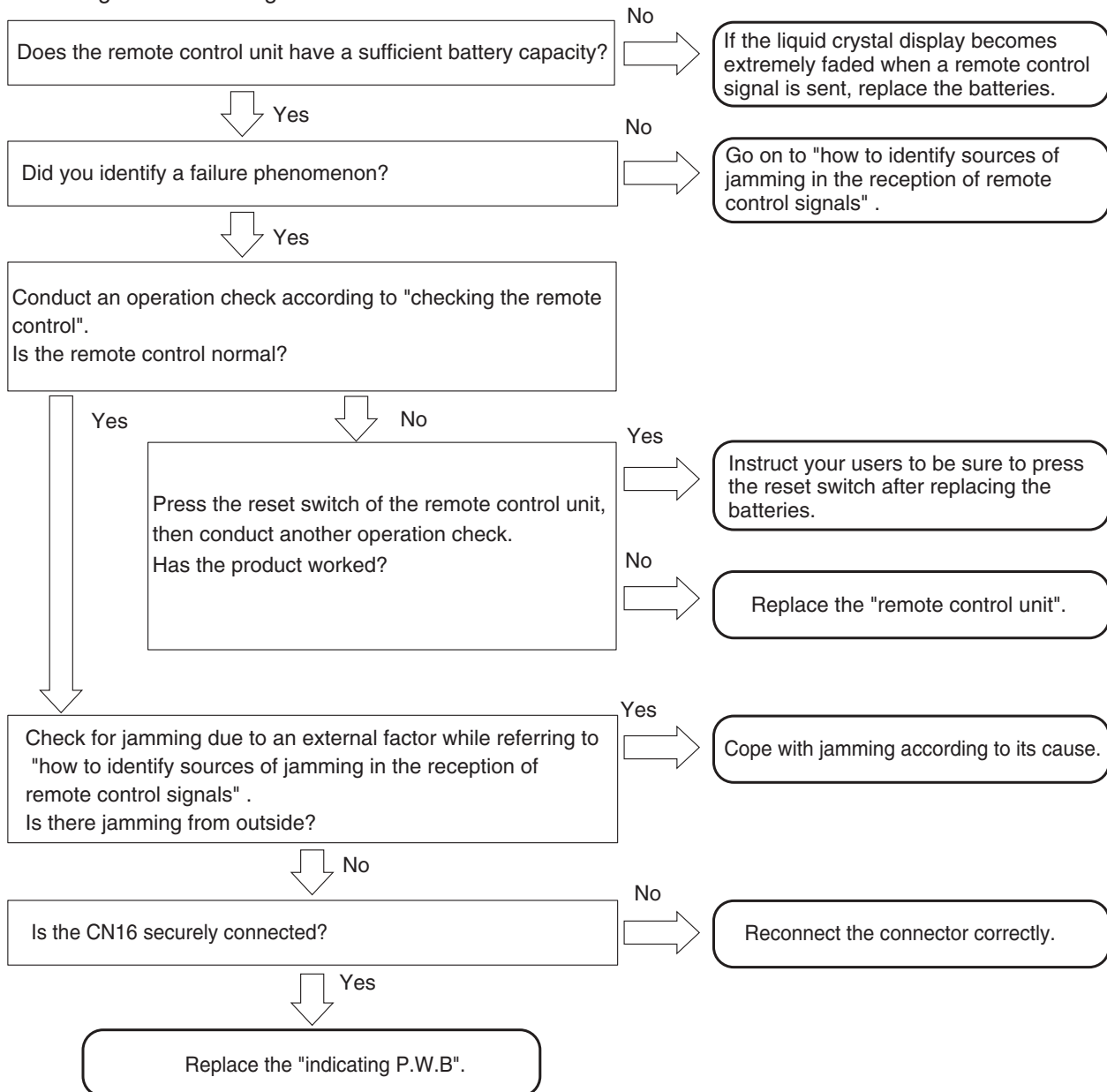


## 2.Failure phenomenon: The product will not receive a remote control signal.

- [Situation ] The product does not receive a remote control signal. It is not very responsive.  
(The product does run normally in response to the emergency operation switch.)
- [Estimated failure locations ]
- Remote control failure, remote control low battery level, remote control poorly set
  - Remote control light-receiving unit
  - Connector loose, wire break
  - Normal product (external factors: the remote control units for lighting equipment and other equipment, electrical noise, etc.)
- [Cautions ]
- Even if the product is trouble-free, a factor coming from outside the product may hamper the reception of signals from the remote control unit.
  - Batteries may decline in capacity at low temperatures. Old batteries decline particularly much in voltage in the morning and evening of winter, resulting in the poor arrival of remote control signals. Instruct your users to use new alkaline batteries.

### [Diagnosis flow ]

#### Initiating troubleshooting



[Cautions in replacing the indicating P.W.B] Be sure to replace the indicating P.W.B. components.

## How to identify sources of jamming in the reception of remote control signals

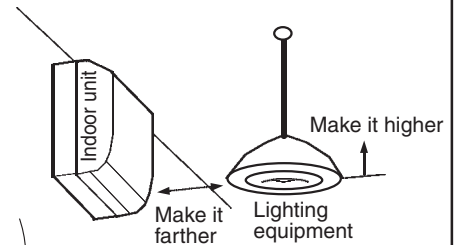
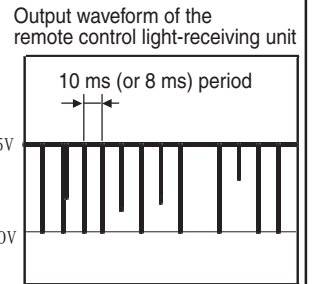
[ Situation ] The product may become poorly responsive to remote control signals due to external factors even though the product itself is trouble-free.

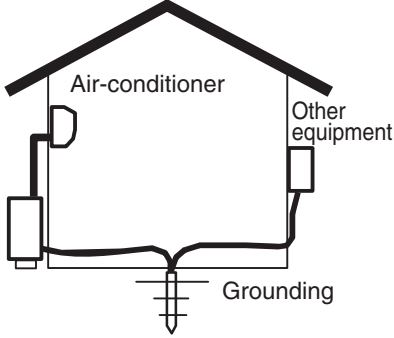
[ Estimating sources of jamming ] Identify the installation status of the air-conditioner and the indoor and outdoor environments to identify possible causes of the jamming.

- Indoor lighting equipment (quantity, type, location)
- Remote control units of other electrical products and equipment
- Is the grounding for the air-conditioner shared with other equipment?
- Are the surroundings of the air-conditioner clear of wireless antenna?
- Is the remote control light-receiving unit protected from direct sunlight?

[ Checking and actions ]

<p>Effects of lighting equipment (fluorescent lamps)</p>	<p><u>Checking points</u></p> <ul style="list-style-type: none"> <li>· Turn on and off the lighting equipment and check for its effects on the reception of remote control signals.</li> <li>· When cold, the fluorescent lamp tends to emit infrared rays with wavelengths close to those used in remote control.</li> </ul> <p>If you cannot detect the phenomenon about which your user is complaining at the time of your visit, such as "the product sometimes fails to receive remote control signals" and "the product fails to receive remote control signals in the morning alone", then turn off the lighting for about 20-30 minutes and wait for the fluorescent lamps to cool down before conducting another check.</p> <p>There are even cases where the product fails to receive remote control signals for 1 to 2 minutes only after the lighting equipment is turned on.</p> <ul style="list-style-type: none"> <li>· The noise status may vary with the dimming of the lighting equipment. In the case of lighting equipment with a dimmer, therefore, conduct a check with all the light intensities.</li> <li>· If the lighting equipment is the source of the jamming, the remote control light-receiving unit output usually shows a noise waveform as shown in the right-hand figure. In the case of slight jamming, this kind of waveform will not cause practical problems. However, intense degrees of jamming will disable the reception of remote control signals.</li> <li>· When the fluorescent lamp is old and is flickering, it may cause disorders in the reception of remote control signals.</li> </ul> <p><u>Actions proposed</u></p> <ol style="list-style-type: none"> <li>1. Make it hard for light of the lighting equipment to enter the remote control light-receiving unit. <ul style="list-style-type: none"> <li>· Separate the lighting equipment from the indoor unit.</li> <li>· Raise the lighting equipment.</li> <li>· Cover the upper half of the light-receiving panel from its rear side with aluminum tape or black vinyl tape.</li> </ul> <p>( This will also affect the reception of remote control signals. Therefore, set the range to be covered with tape to a range that is problem-free in practice, while checking the reception status. )</p> </li> <li>2. Add an interference filter to the front panel of the remote control light-receiving unit. <ul style="list-style-type: none"> <li>※ Lighting equipment that produces strong jamming exists although rarely.</li> <li>Some problems may therefore be unsolvable by managing the air-conditioner side alone.</li> </ul> </li> </ol>
<p>Effects of the remote control units of other equipment</p>	<p><u>Checking points</u></p> <ul style="list-style-type: none"> <li>· If, on the remote control unit of a TV or audio equipment, its sound volume key or something similar is left pressed, infrared signals become continuously sent, thereby jamming the reception of remote control signals.</li> <li>· Check how the remote control unit and related components are stored, thereby checking if there is any possibility that a button may be inadvertently left pressed on the remote control unit of other equipment.</li> </ul> <p><u>Actions proposed</u></p> <p>If there is any such possibility, give explanations to your users to that effect and instruct them to exercise caution.</p>



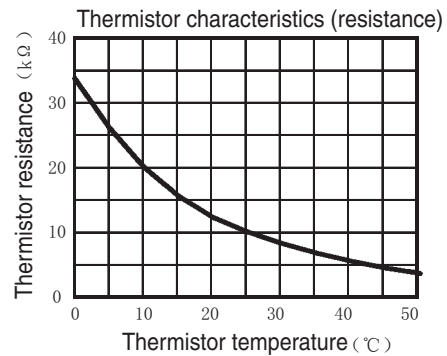
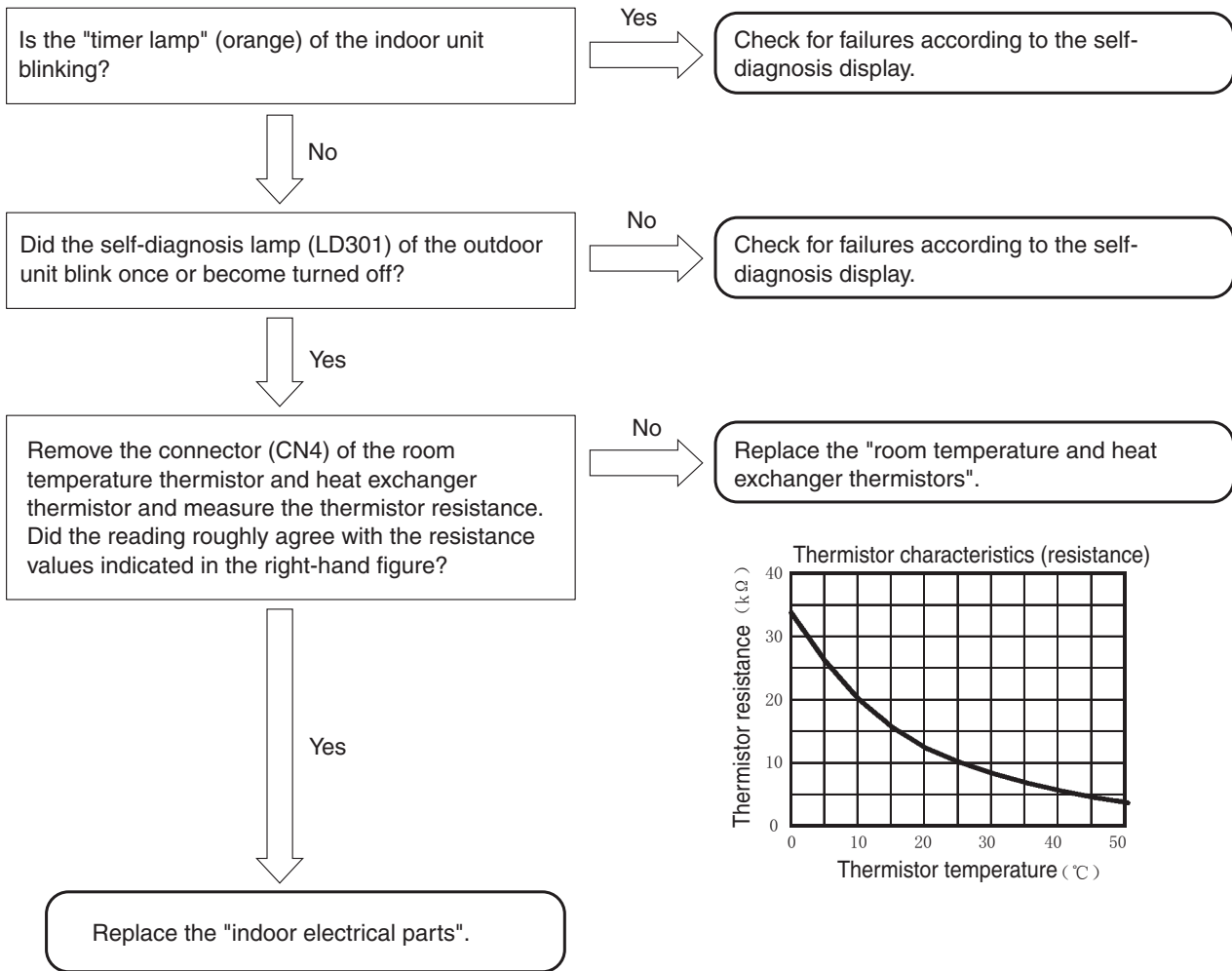
<p>Effects of other electrical products</p>	<p><u>Checking points</u></p> <ul style="list-style-type: none"> <li>· Check the effects of light and power noises coming from other electrical products.</li> <li>· Turn on and off the electrical products, turn off the power and turn on the power, and check their effects on the reception of remote control signals.</li> <li>· For products whose operating states change, check the effects of each state.</li> </ul> <p><u>Actions proposed</u></p> <ul style="list-style-type: none"> <li>· Change the location relationship between the air-conditioner and the target products.</li> <li>· Use a different wall outlet for the target products.</li> </ul>
<p>Sharing a grounding</p>	<p><u>Checking points</u></p> <ul style="list-style-type: none"> <li>· Check for effects of electrical noises coming into the air-conditioner through grounding wires.</li> <li>· Check if the grounding works is for the air-conditioner alone or shared with other equipment. If there is any equipment that shares it, turn on and off that equipment and detach and reattach the power plugs and examine their effects on the reception of remote control signals.</li> </ul> <p><u>Actions proposed</u></p> <ul style="list-style-type: none"> <li>· Establish an independent grounding for the air-conditioner.</li> </ul>  <p>The diagram shows a cross-section of a house with a gabled roof. Inside, there is an 'Air-conditioner' on the left wall and 'Other equipment' on the right wall. Both are connected to a single horizontal line representing a shared grounding system. This line leads to a vertical line labeled 'Grounding' which is connected to a ground symbol (three horizontal lines of decreasing width) at the bottom center.</p>
<p>Effects of radio waves</p>	<p><u>Checking points</u></p> <ul style="list-style-type: none"> <li>· Using a wireless transmitter near the air-conditioner may affect the reception of remote control signals.</li> <li>· Have your users try sending signals with a wireless transmitter and examine their effects on the reception of remote control signals.</li> </ul> <p><u>Actions proposed</u></p> <ul style="list-style-type: none"> <li>· Add a ferrite core to the power cord and F cable.</li> <li>· Add a ferrite core to the internal wiring of the indoor unit.</li> <li>· Move the wireless antenna.</li> </ul>
<p>Effects of direct sunlight</p>	<p><u>Checking points</u></p> <ul style="list-style-type: none"> <li>· Direct sunlight and other intense light make the remote control light-receiving unit less sensitive.</li> <li>· Check for any time zone where the remote control light-receiving unit of the indoor unit is affected by direct sunlight depending on the location of the sun and mirror reflection.</li> </ul> <p><u>Actions proposed</u></p> <ul style="list-style-type: none"> <li>· Block the sunlight to protect against direct sunlight.</li> </ul>

### 3. Failure phenomenon: The compressor will not run.

[ Situation ] The compressor will not run (the same state as the thermometer turned off), the product receives remote control signals normally. The self-diagnosis lamp (LD301) of the outdoor unit blinks once or becomes turned off.

[ Estimated failure locations ] · Room temperature thermistor, heat exchanger thermistor  
· Microcomputer peripheral circuit

[ Diagnosis flow ]  
Initiating troubleshooting



#### 4. Failure phenomenon: The fan motor will not stop.

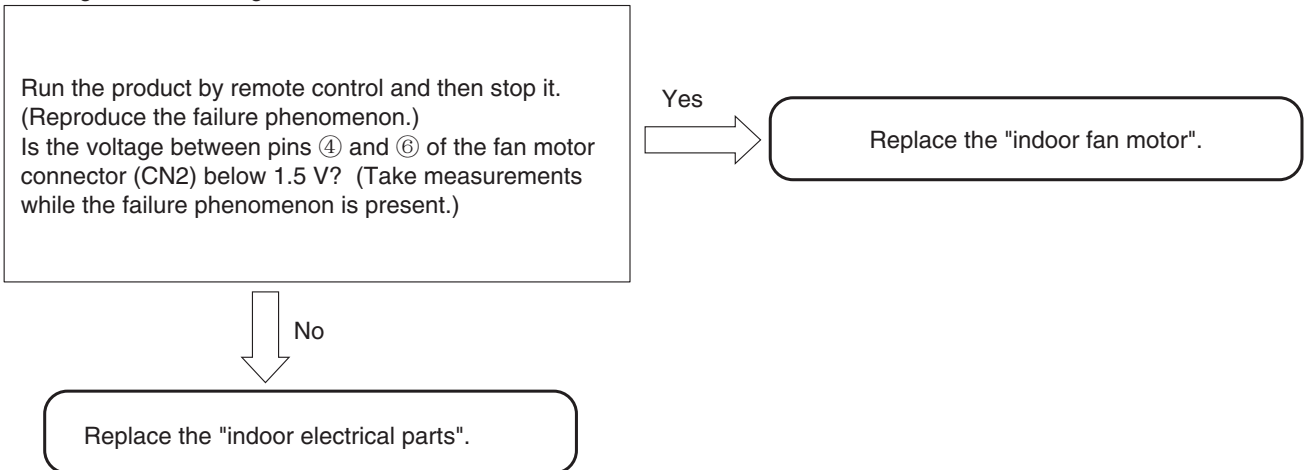
[Situation ] I have conducted the stop operation on the product by remote control, but the indoor fan motor will not stop.  
(It stopped about 10 minutes later.)

[Estimated failure locations ]

- Indoor fan motor
- Fan motor drive circuit

[Diagnosis flow ]

Initiating troubleshooting



### 5. Timer lamp blinking: blinking once

[Situation] The timer lamp blinks one time and the product will not operate.  
(This is not a sign of a breakdown.)

[Estimated failure locations] · Reversing valve defective.  
· The refrigerating cycle block gas leak.

### 6. Timer lamp blinking: blinking twice

[Situation] The product is giving a display to indicate that it is performing forcible cooling.  
(This is not a sign of a breakdown.)

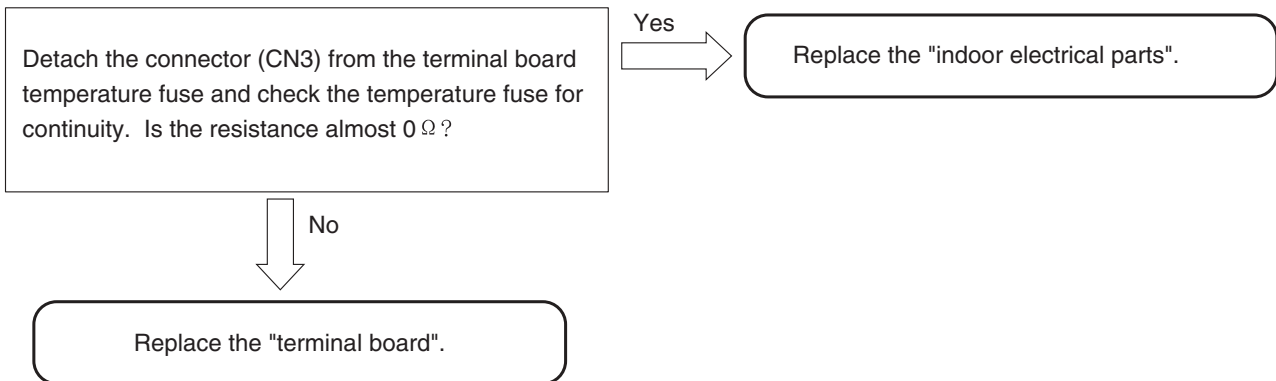
### 7. Timer lamp blinking: blinking three times

[Situation] The timer lamp blinks three times and the product will not operate.

[Estimated failure locations] · Meltdown of the terminal board temperature fuse (the terminal board poorly inserted into the F cable)  
· Outdoor communication circuit out of order

[Cautions] · If a terminal board is replaced to counter the meltdown of the terminal board temperature fuse, ensure that the F cable to be inserted into the terminal board has the appropriate dimension for peeling the insulation sheathing and that the insertion region is unbent before inserting it into the terminal board securely.

[Diagnosis flow]  
Initiating troubleshooting



### 8. Timer lamp blinking: blinking four times

[Situation] The timer lamp blinks four times and the product will not operate.

[Estimated failure locations] · Outdoor unit error.  
· Please confirm the times of the LD301 blinking, and then see the outdoor selfcheck table.

### 9. Timer lamp blinking: blinking 9 times

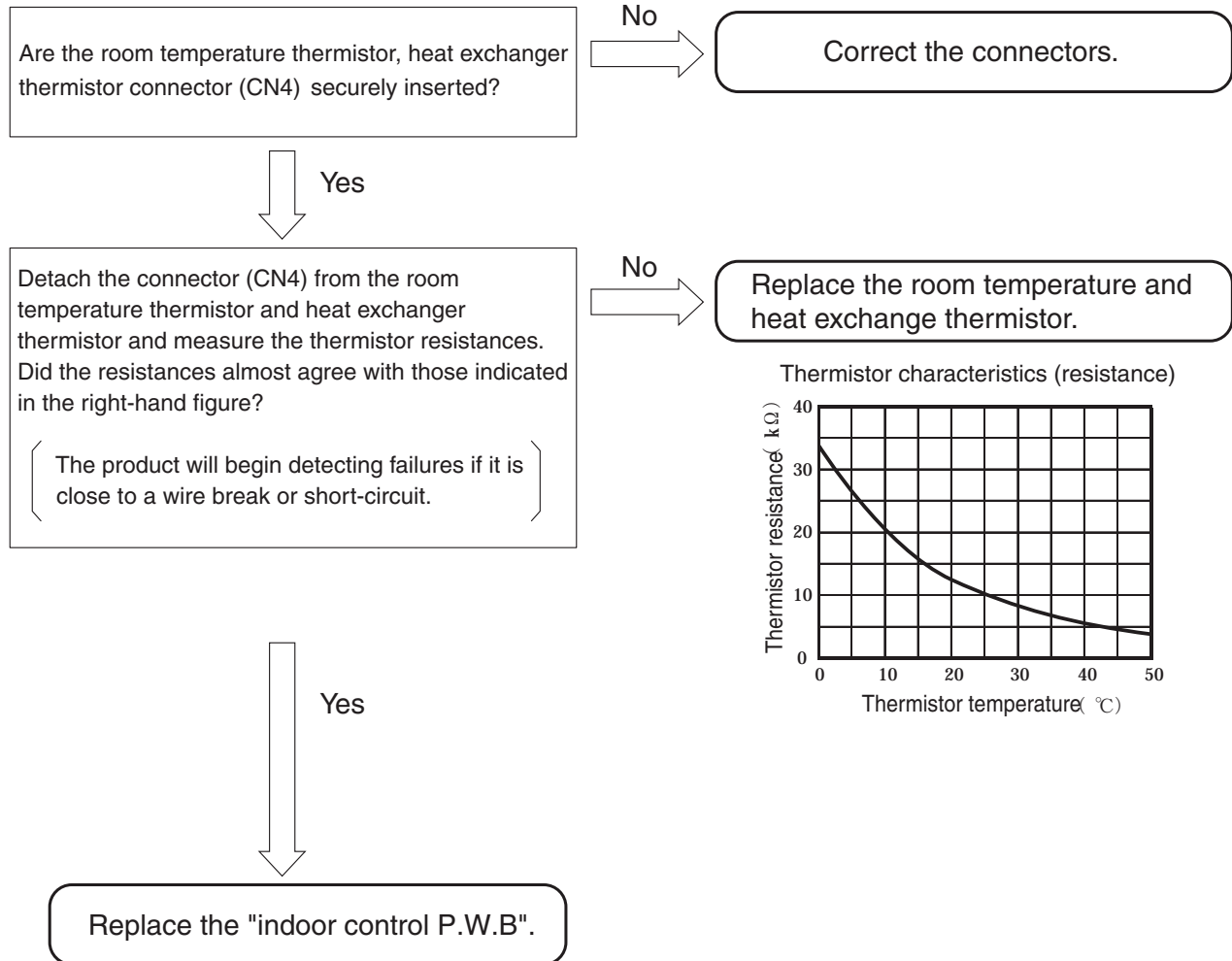
[Situation] The timer lamp blinks 9 times and the product will not run.

[Estimated failure location] • Loose connector, wire break, or short-circuit in the room temperature thermistor, heat exchanger thermistor.

[Cautions] • Starting the product by remote control will initiate failure detection.  
(Merely turning on the power will not activate the failure detection function.)

#### [Diagnosis flow]

##### Initiating troubleshooting



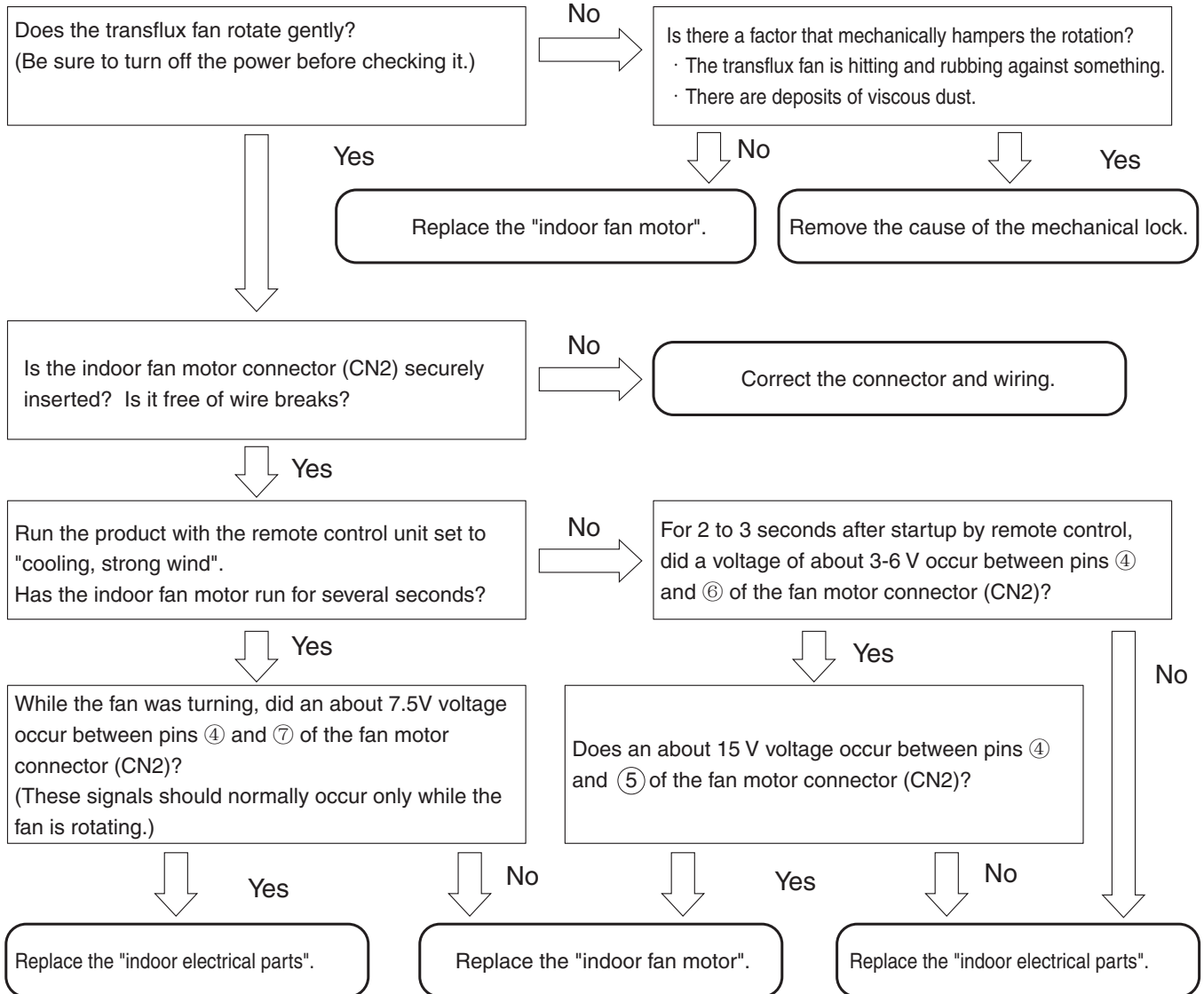
## 10. Timer lamp blinking: blinking 10 times

[Situation] The timer lamp blinks 10 times and the product will not run.

- [Estimated failure locations]
- Loose connector or wire break in the indoor fan motor
  - Indoor fan motor mechanically locked
  - Indoor fan motor
  - Indoor fan motor drive circuit

[Diagnosis flow]

Initiating troubleshooting





## 11. Timer lamp blinking: blinking 12 times

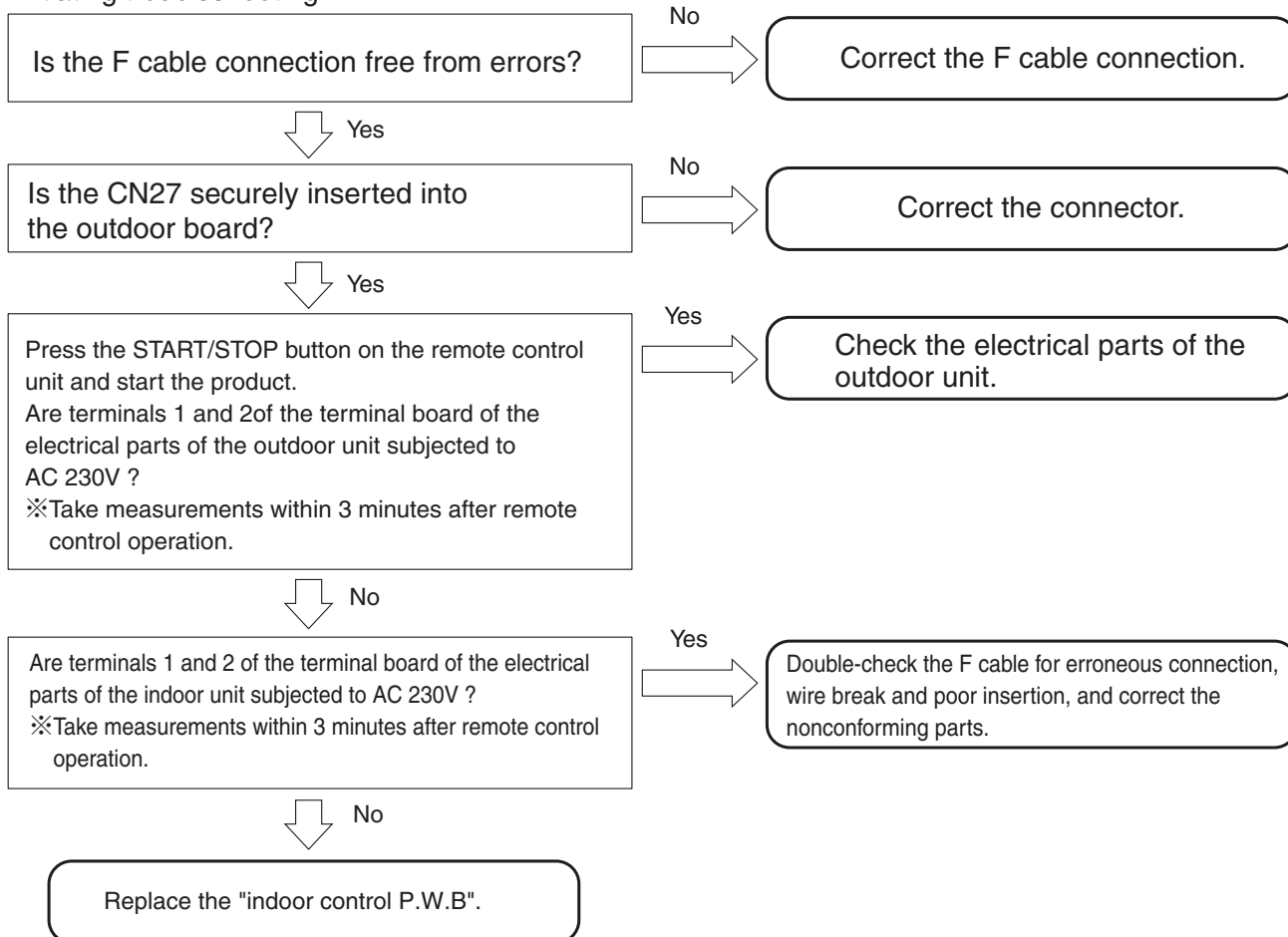
[Situation] The timer blinks 12 times and the product will not run.

- [Estimated failure locations]
- Erroneous connection in the indoor-outdoor connection line (F cable)
  - Forget to connect CN27 of outdoor P.W.B
  - Wire break or poor insertion of the indoor-outdoor connection line (F cable)
  - Electrical parts in the outdoor unit (communication circuit, power circuit error)
  - Communication error due to noise in other home electronics
  - ※ This does not constitute a failure in the air-conditioner

[Cautions] • When lines 1 and 2 of F cable are erroneously connected (crossed), the product may not enter self-diagnosis display mode. If the self-diagnosis memory stores data about "timer lamp blinked 12 times", then, just in case, check if the F cable is not erroneously connected.

[Diagnosis flow]

Initiating troubleshooting



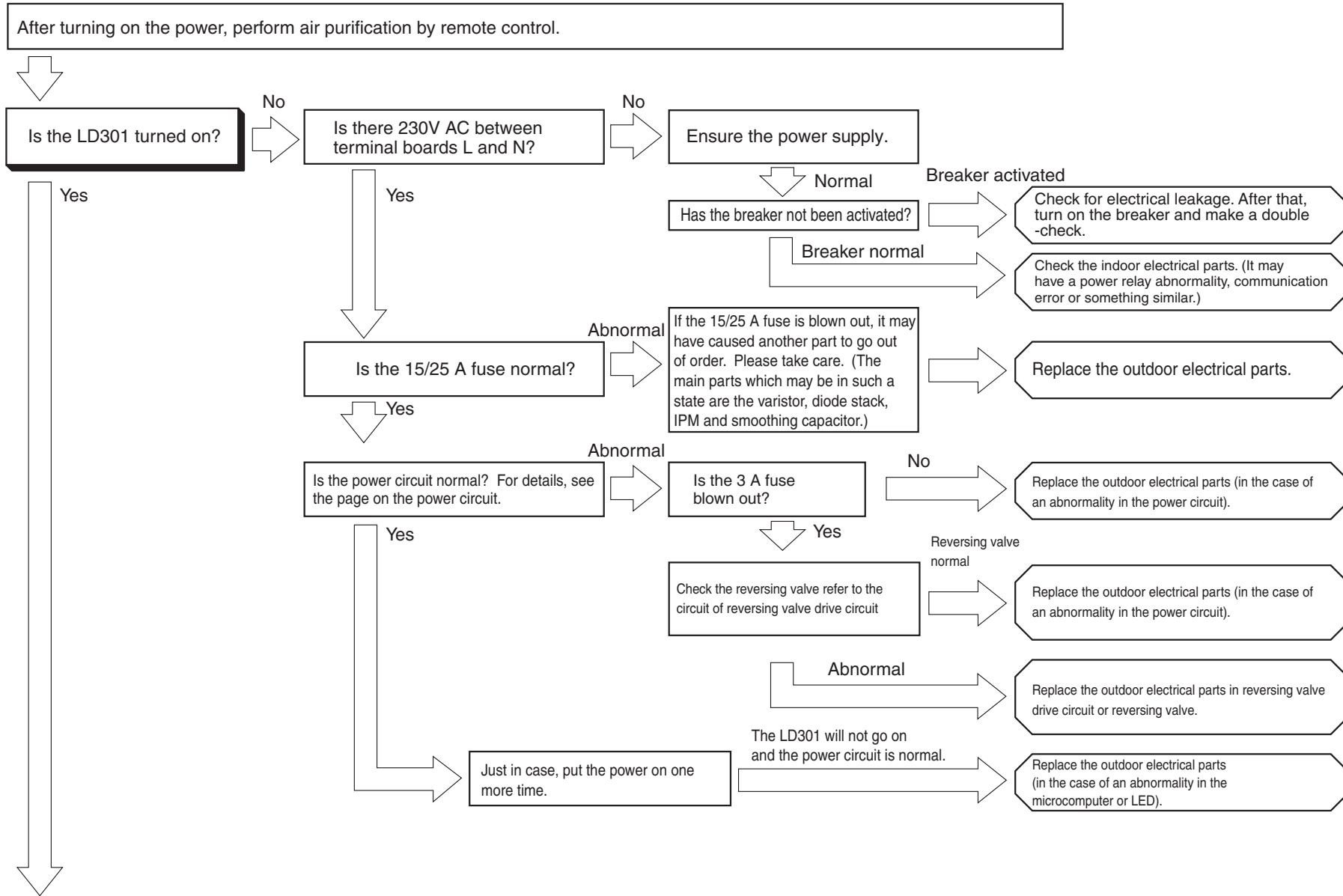
## 12. Timer lamp blinking: blinking 13 times

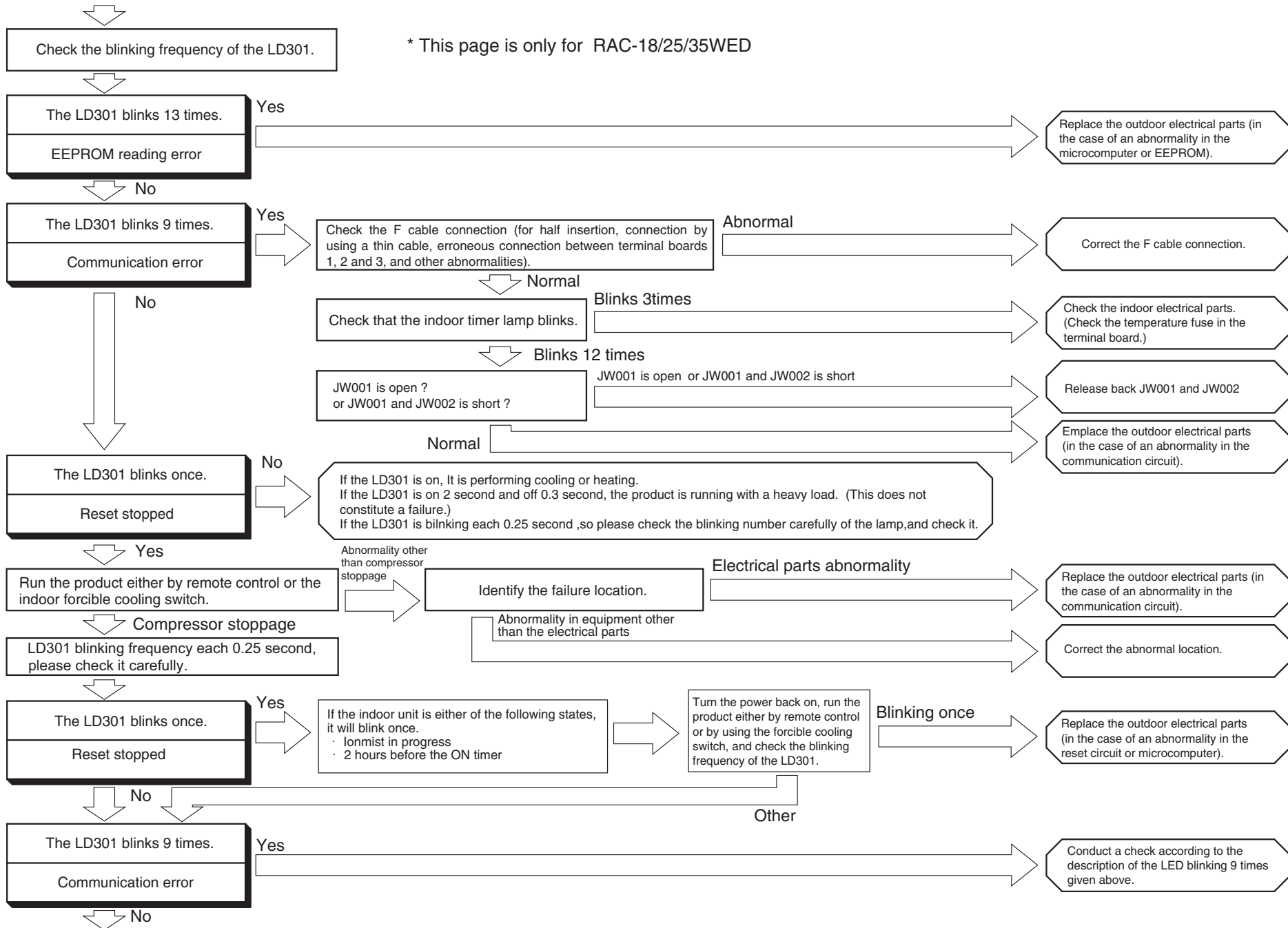
[Situation] The timer lamp blinks 13 times and the product will not run.

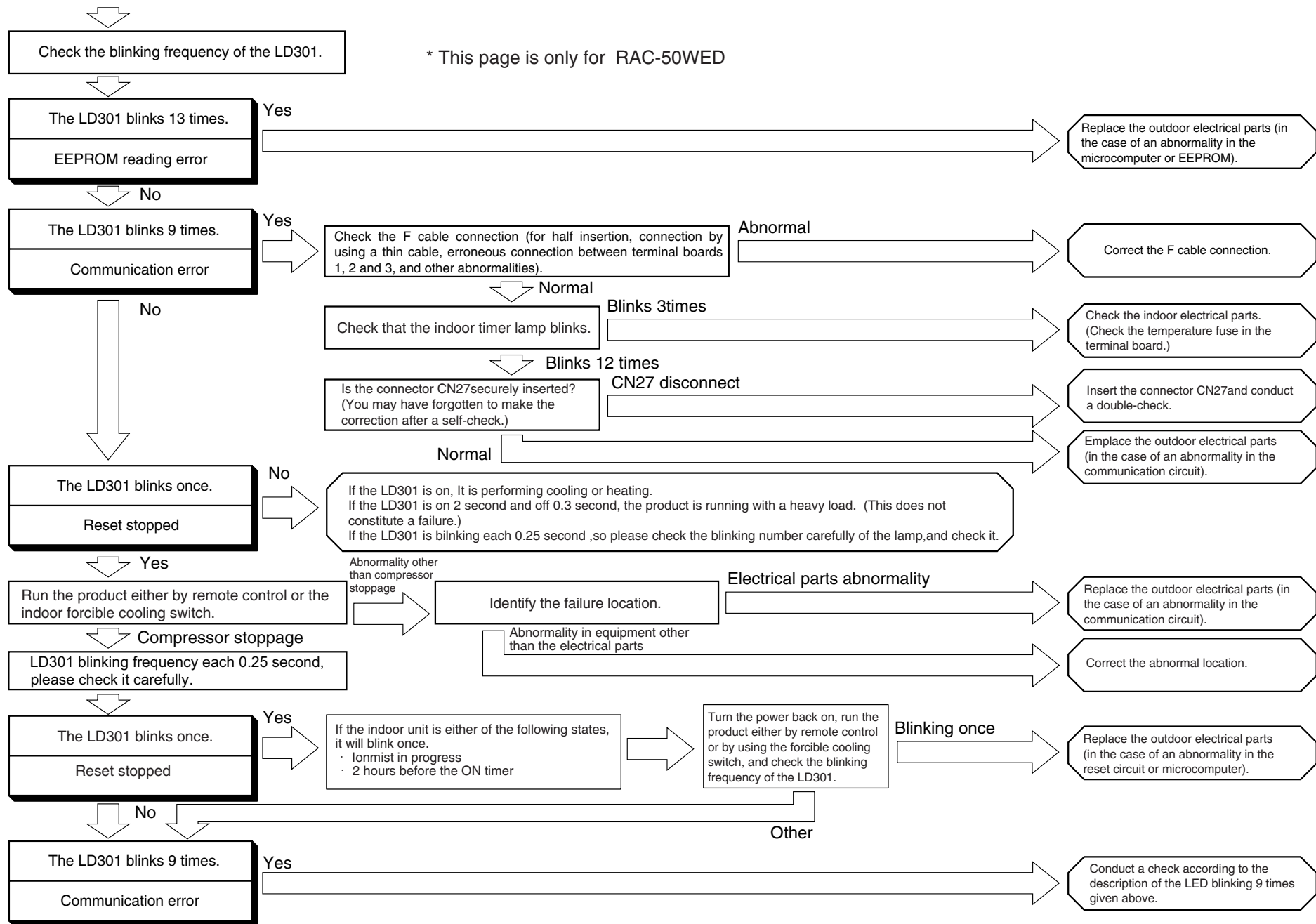
[Estimated failure location] • EEPROM, microcomputer

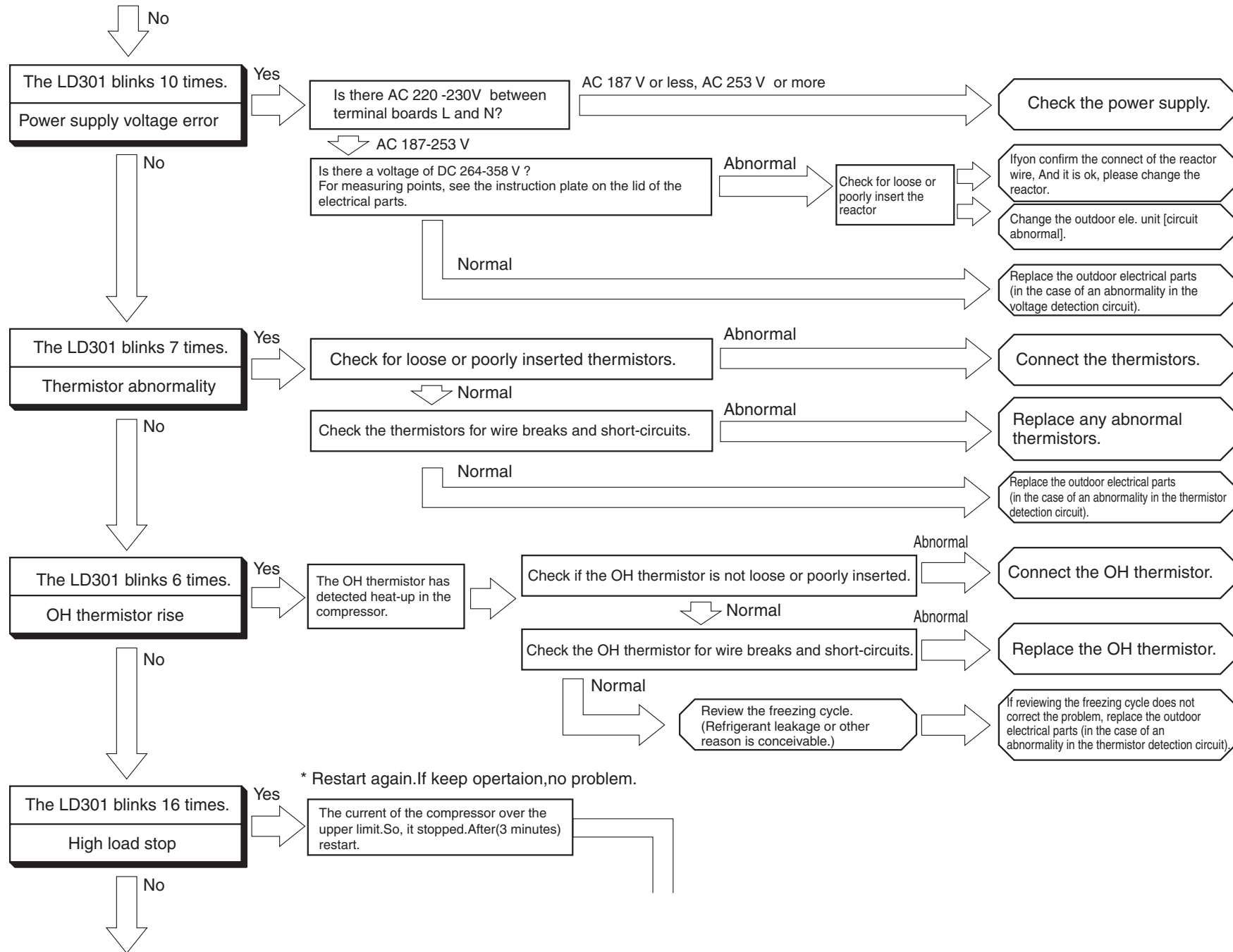
[Diagnosis flow]

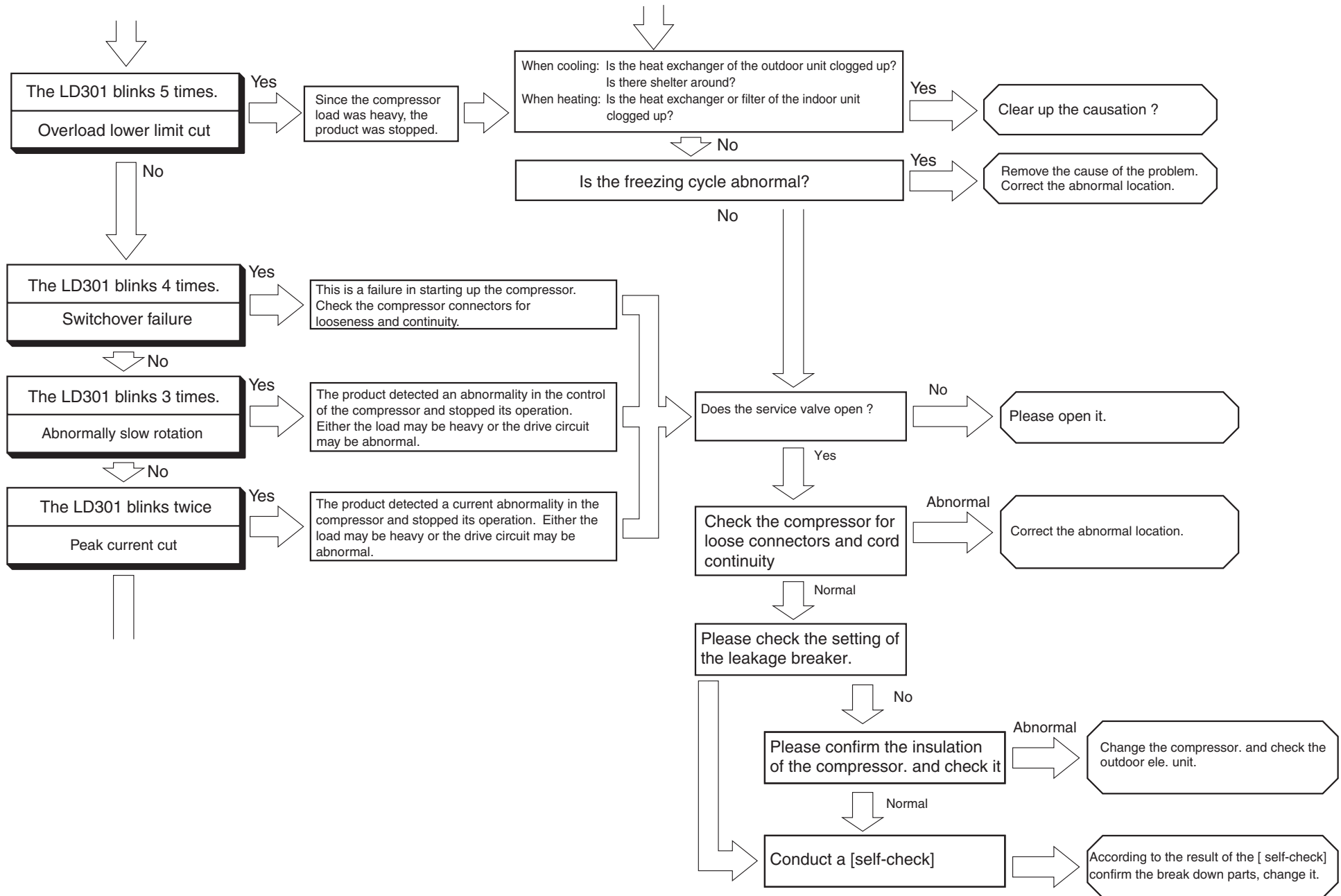
Replace the "indoor control P.W.B".

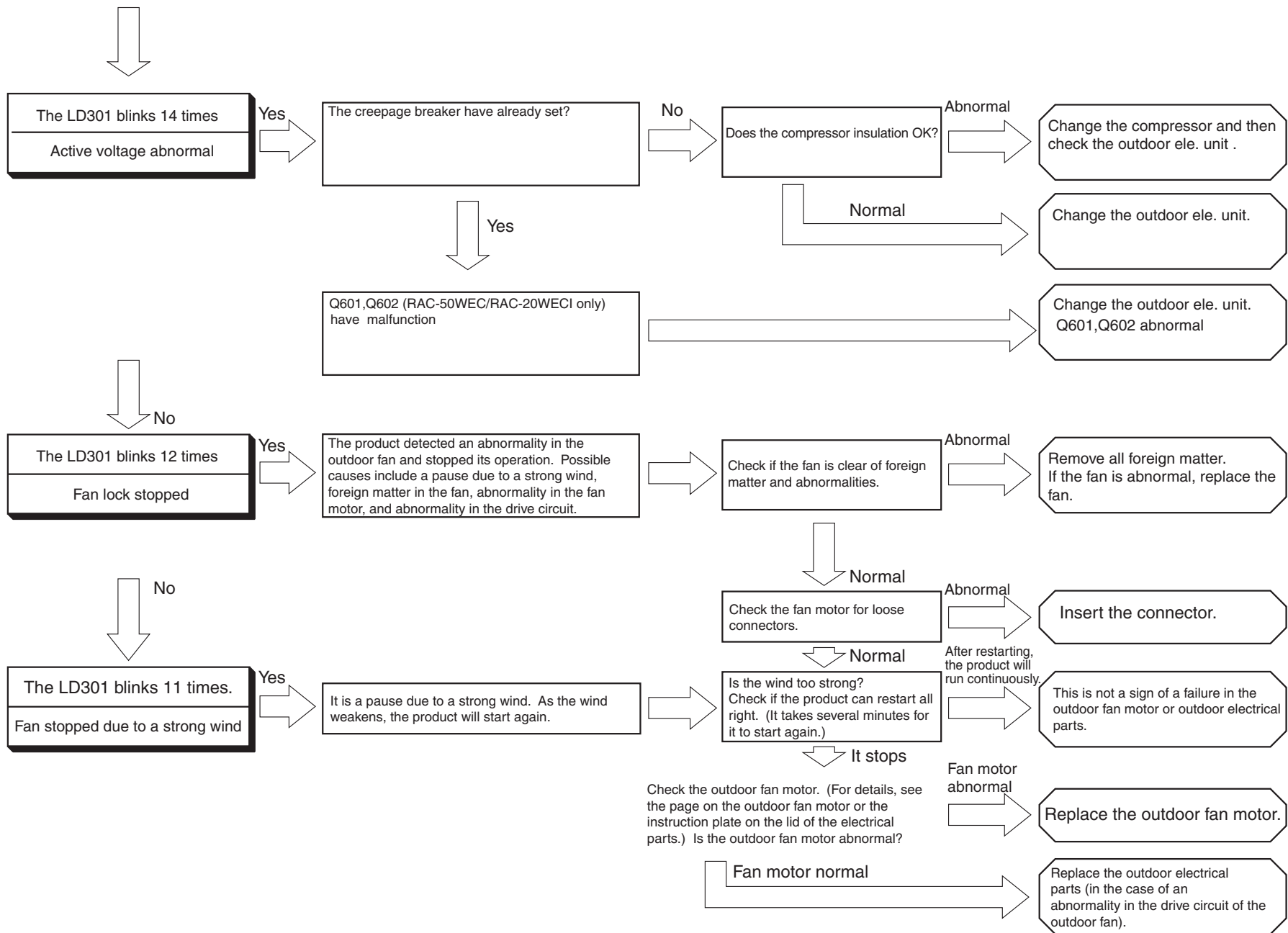












## SETTING THE PREVENTION OF MUTUAL INTERFERENCE FOR REMOTE CONTROLLER

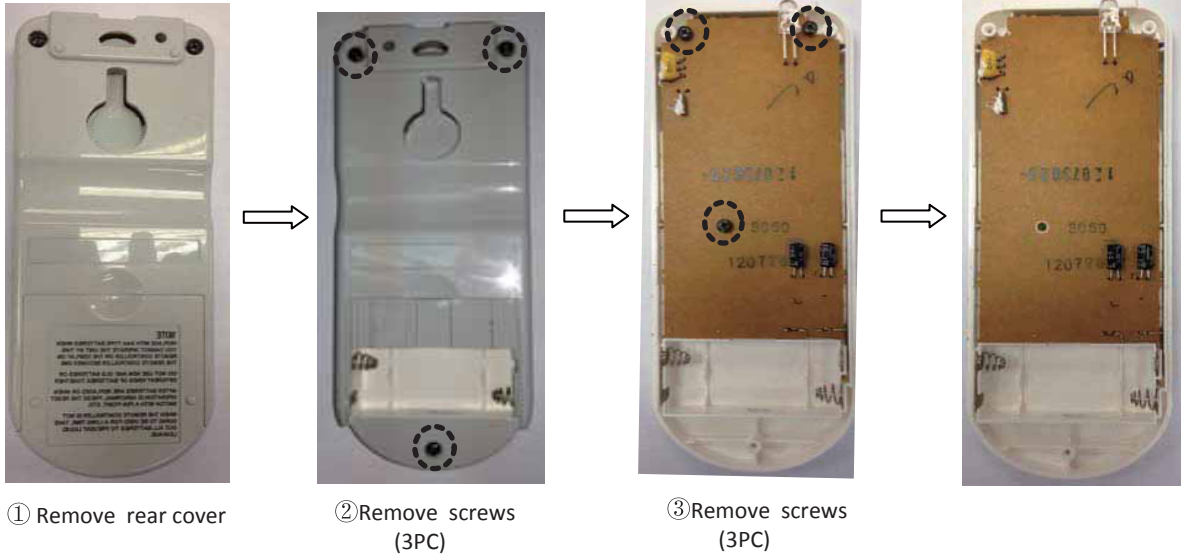
Case : 2 sets of indoor units installed near to each other.

If both indoor units can receive the same remote controller signal, please set the remote controller as below. ( This setting will change the signal address of each remote controller.)

Initial remote controller signal address setting is A.

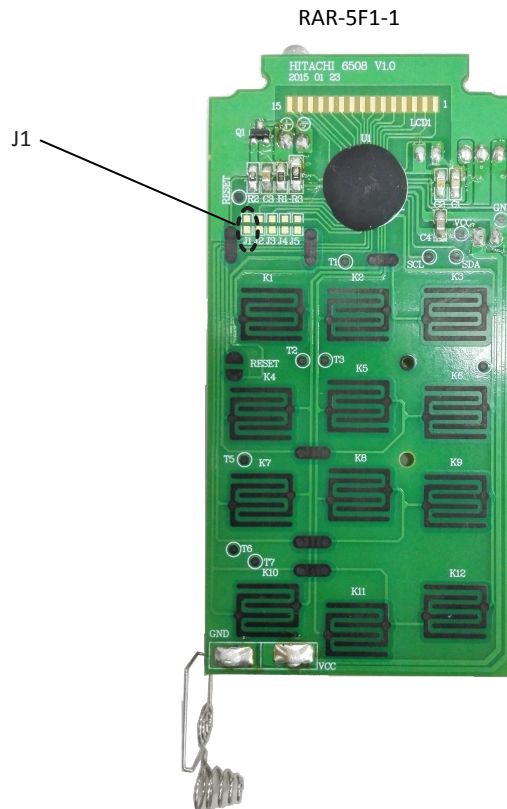
This procedure change the remote controller signal address from A to B.

1.Remove rear cover as shown in figure



2.Short the J1 ON PCB according to different supplier.

For distinguishing them, we attached different type label in the battery case as below.









NOTE: Please set the DIP switch No.6 to ON accordingly (Refer to page 52).



## HOW TO CHANGE THE SHIFT VALUE SETTING TEMPERATURE

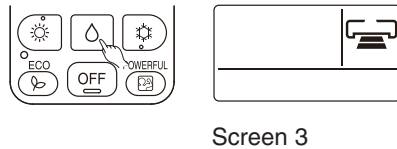
The shift value setting temperature for Cooling and Heating mode operation can be changed using a remote controller. (This procedure shall be implemented strictly by service personnel only.)

### PROCEDURES

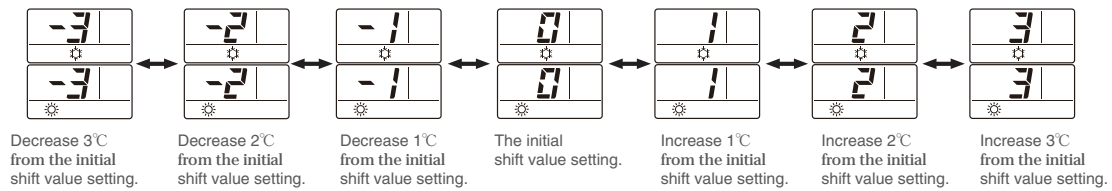
1. Press and hold  (OFF) button and  (ON) button.
2. Press  [RESET] button at the same time. Release  [RESET] button only, then release  (OFF) and  (ON) button once Screen 1 appears.




3. Press the  button to display  fan mode (Screen 3).

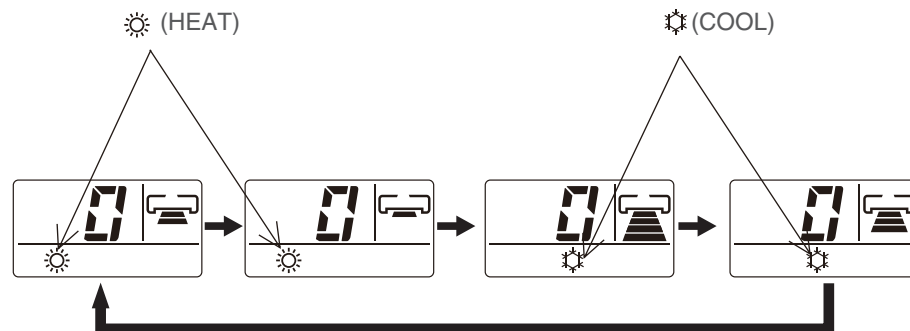


1. Press the Temperature button ( or ) to change the shift value. (The shift value is changed with a beep.)





2. Select  (FAN SPEED) button to choose Heating Shift or Cooling Shift Mode (Screen 4).

By setting fan speed to HIGH  or MED , it will go to Cooling Shift mode.  
By setting fan speed to LOW  or SILENT , it will go to Heating Shift mode.



Screen 4

### NOTE:

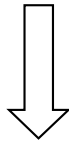
1. There are total of 7 shift values ranging from -3 to 3.
2. The displayed shift value,  (HEAT) and  (COOL) symbol on the remote controller display will disappear after 10 seconds.
3. The changed shift value will remain unchanged after turned off the power.
4. If "0" is displayed on the remote controller display, it indicates the shift value is now at the initial setting.

# CHECKING THE REFRIGERATING CYCLE

## (JUDGING BETWEEN GAS LEAKAGE AND COMPRESSOR DEFECTIVE)

### 1. Troubleshooting procedure (No operation, No heating, No cooling)

Connect U,V,W phase leads to the power module again and operate the air conditioner.



Is the self-diagnosis lamp mode as shown on the right?

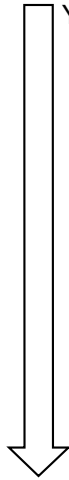
Lighting mode Self-diagnosis lamp	Blinks 2 times	Blinks 3 times	Blinks 4 times	Blinks 5 times	Blinks 6 times	Blinks 8 times
LD301						
Time until the lamp lights	Approx. 10 seconds			Approx. 10 seconds	Within Approx. 30 seconds	Approx. 10 seconds
Possible malfunctioning part	Compressor				Gas leakage	Compressor

Blinking off

Outdoor air temperature (°C)	Charge port pressure MPa(G) {kgf/cm <sup>2</sup> (G)}
50	2.96 {30.14}
45	2.62 {26.72}
40	2.31 {23.58}
35	2.03 {20.73}
30	1.78 {18.14}
25	1.55 {15.79}
20	1.34 {13.66}
15	1.15 {11.74}
10	0.98 {10.02}
5	0.83 {8.48}
0	0.70 {7.10}
-5	0.58 {5.89}
-10	0.47 {4.81}

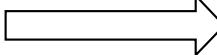
(R32)  
The values above are the theoretical ones.

YES



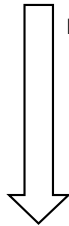
Stop to operate and check the gas pressure in balancing mode.

Normal



• Checking the IPM (main P.W.B.)

Error (Gas leaking)

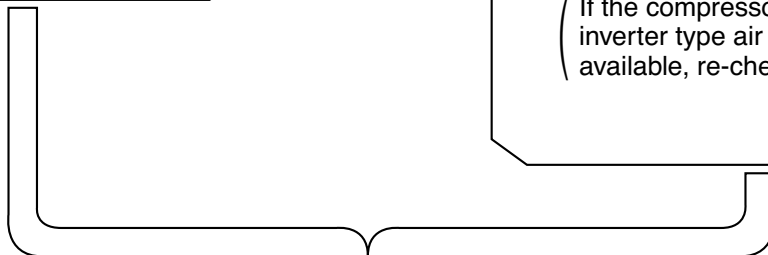


Gas leaks.  
Repair and seal refrigerant.

When the self-diagnosis lamp lights in the same condition as above.



The compressor is defective. Replace it and seal refrigerant.  
( If the compressor checker for an inverter type air conditioner is available, re-check using it. )



Perform a final check of operation.

## How to run the product with the outdoor unit test switch

If the indoor electrical parts is out of order and if you wish to run the outdoor unit

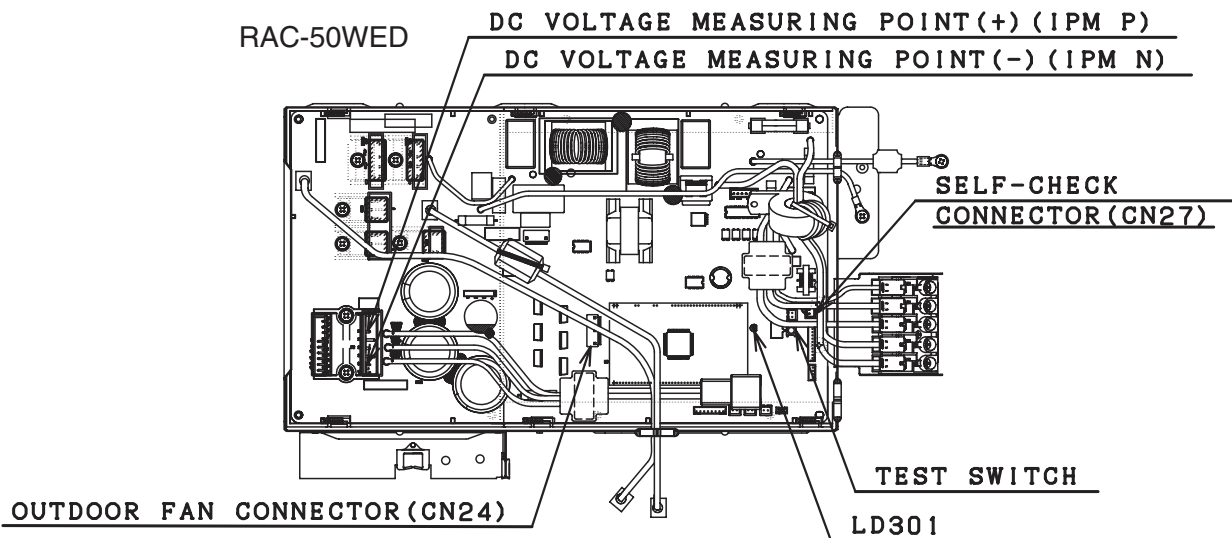
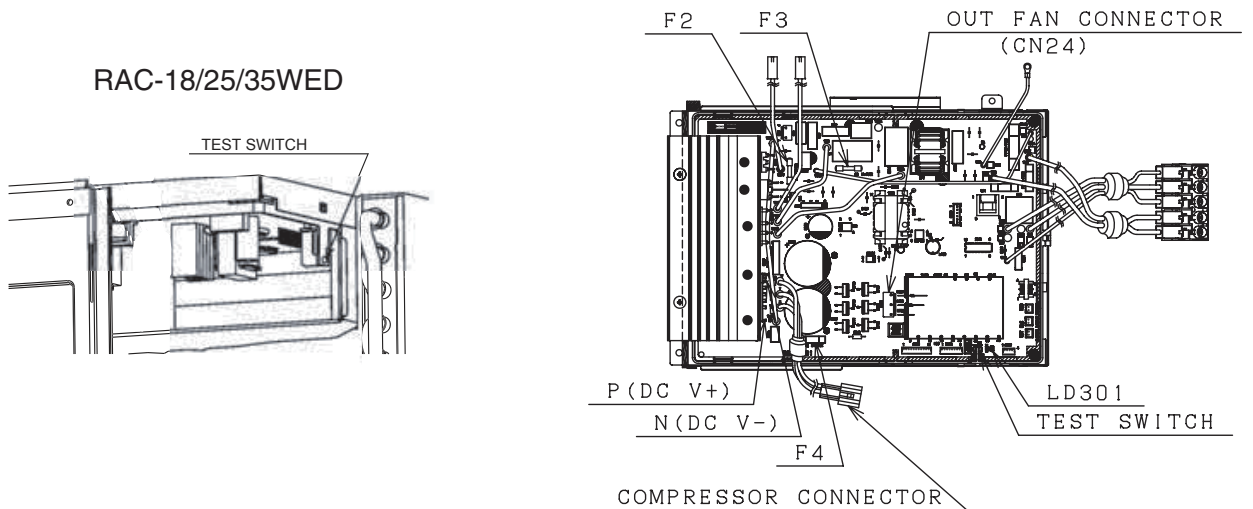
1. Turn on the outdoor terminal boards L and N (220-230 V AC).
2. Confirm that the "LD301" blinks once from the terminal side of the outdoor unit. Afterwards (when about 30 sec elapses after the power turns on), confirm that the "LD301" changes to blinking 9 times (communication error).
3. When the "LD301" is blinks 9 times, if you press the test switch, the "LD301" lights up.

If you release your finger from the test switch within 1 sec to 5 sec after pressing the switch, the forced cooling operation starts.

※(If you press the test switch for 5 sec or longer, the self-check diagnosis starts. In this case, turn the power off and start the procedure from 1 again.)

※(For the initialization of the expansion valve, it may take 1 min until the operation starts.)

4. When you press the test switch again for 1 sec or longer, the unit stops the operation.



※Cautions

1. Applying power directly to the outdoor unit will cause a rush current to stress the outdoor unit. Therefore, if the indoor unit is not out of order, do not use the method described in 2).
2. Before making the connections, be sure to turn off the breaker.
3. Do not under any circumstances run the product for more than 5 minutes.
4. Doing work with the compressor connector removed will cause the LD301 to blink 4 times. It will not start.
5. For another test run, turn off the breaker and turn it back on. (The test switch is accepted only once after power-on. After operation by remote control, it is not accepted.)
6. When the operation with the test switch is over, turn off the breaker and set the connectors back.

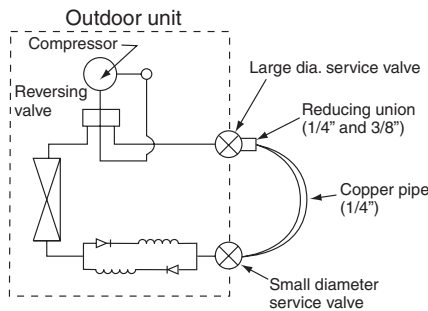
## HOW TO OPERATE THE OUTDOOR UNIT INDEPENDENTLY

### RAC-18/25/35WED

1. Connect the large dia. pipe side and small dia. pipe side service valve using a pipe.

Connect the small diameter service valve and the large diameter service valve using the reducing union and copper pipe as shown on the right.

Charge refrigerant of 300g after vacuuming (※1)



#### Parts to be prepared

- (1) Reducing union  
1/4" (6.35 mm)  
3/8" (9.52 mm)
- (2) Copper pipe (1/4" and 3/8")

Do not operate for more than 5 minutes

The operation method is the same as "How to operate using the connector to servicing the outdoor unit".

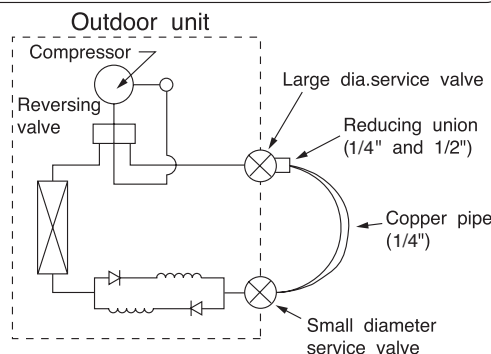
※1 The charging amount of 300g is equivalent to the load in normal operation.

### RAC-50WED

1. Connect the large dia. pipe side and small dia. pipe side service valves using a pipe.

Connect the small diameter service valve and the large diameter service valve using the reducing union and copper pipe as shown on the right.

Charge refrigerant of 300g after vacuuming (※1)



#### Parts to be prepared

- (1) Reducing union  
1/4" (6.35mm)  
1/2" (12.7mm)
- (2) Copper pipe (1/4" and 1/2")
- (3) Shorting leads  
2 leads approx. 10 cm long with alligator clip or IC clip

Do not operate for 5 minutes or more.

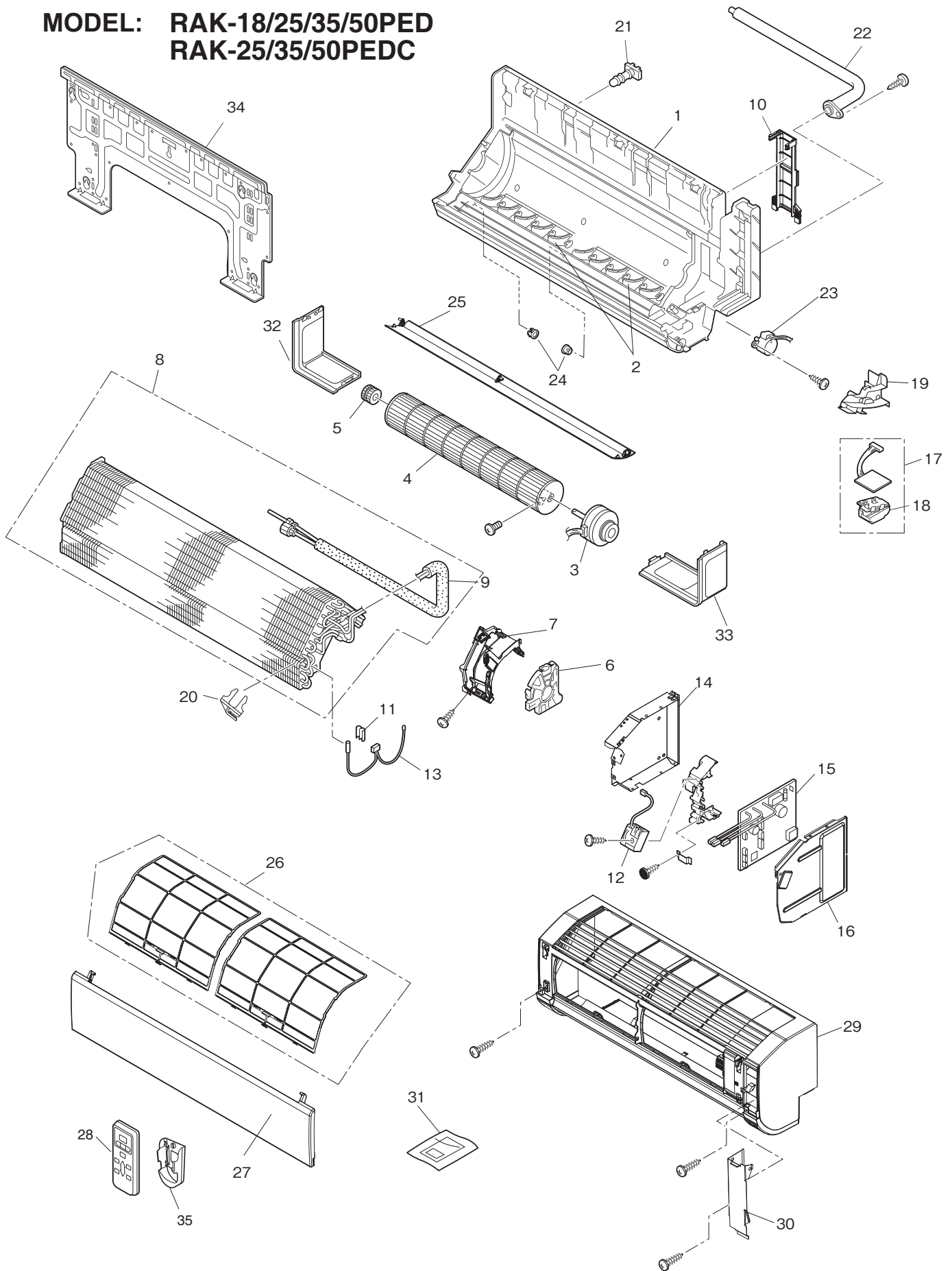
The operation method is the same as "How to operate using the connector to servicing the outdoor unit".

※1 The charging amount of 300g is equivalent to the load in normal operation.

# PARTS LIST AND DIAGRAM

## INDOOR UNIT

MODEL: **RAK-18/25/35/50PED**  
**RAK-25/35/50PEDC**



## INDOOR UNIT

### MODEL: RAK-18/25/35/50PED

NO	HHAW PARTS NO				Q'TY/ UNIT	PARTS NAME
	RAK-18PED	RAK-25PED	RAK-35PED	RAK-50PED		
1	HWRAK-18PED A01				1	CABINET ASS'Y
2	HWRAK-18PED A02				2	VERTICAL AIR DEFLECTOR
3	HWRAS-K10HCG 903				1	FAN MOTOR
4	HWRAK-18PSPA 902				1	TANGENTIAL AIR FLOW FAN
5	HWRAK-18PED A03				1	FAN SUPPORT ASS'Y
6	HWRAK-18PED A04				1	FAN MOTOR SUPPORT-R
7	HWRAK-18PED A05				1	FAN MOTOR SUPPORT-L
8	HWRAK-18PED A06			HWRAK-50PED A01	1	EVAPORATOR ASS'Y
9	HWRAK-18PED A07			HWRAK-50PED A02	1	PIPING ASS'Y
10	HWRAK-18PED A08				1	UPPER COVER
11	HWRAK-18PED A09			HWRAS-25YH4 A15	1	SPRING
12	HWRAS-K10HCG 908				1	TERMINAL BOARD (3P)
13	HWRAK-18PED A10				1	THERMISTOR ASS'Y
14	HWRAK-18PED A11				1	COVER (ELECTRIC)
15	HWRAK-18PED A12	HWRAK-25PED A01	HWRAK-35PED A01	HWRAK-50PED A03	1	P. W. B. (MAIN)
16	HWRAK-18PED A13				1	ELEC-COVER
17	HWRAK-18PED A14				1	INDICATION BOX
18	HWRAK-18PED A15				1	LED-COVER
19	HWRAK-18PED A16				1	FC-GUIDE
20	HWRAK-18PED A17				1	PIPE COVER
21	HWRAK-18PSPA 919				1	DRAIN CAP
22	HWRAS-E10H3 921				1	DRAINAGE PIPE
23	HWRAK-18PED A18				1	STEPPING MOTOR
24	HWRAS-25YH4 A28				2	DEFLECTOR SUPPORT
25	HWRAK-18PED A19				1	HORIZONTAL AIR DEFLECTOR
26	HWRAK-18PED A20				2	AIR FILTER
27	HWRAK-18PED A21				1	FRONT PANEL AS
28	HWRAS-K10HCG 919				1	REMOTE CONTROL ASS'Y
29	HWRAK-18PED A22				1	FRONT COVER
30	HWRAK-18PED A23				1	T-COVER ASS'Y
31	HWRAK-18PED A24				1	H-LABEL
32	HWRAK-18PED A25				1	S-COVER-L
33	HWRAK-18PED A26				1	S-COVER-R
34	HWRAK-18PED A27				1	MOUNTING PLATE
35	HWRAS-E10CXK 014				1	RE-HOLDER

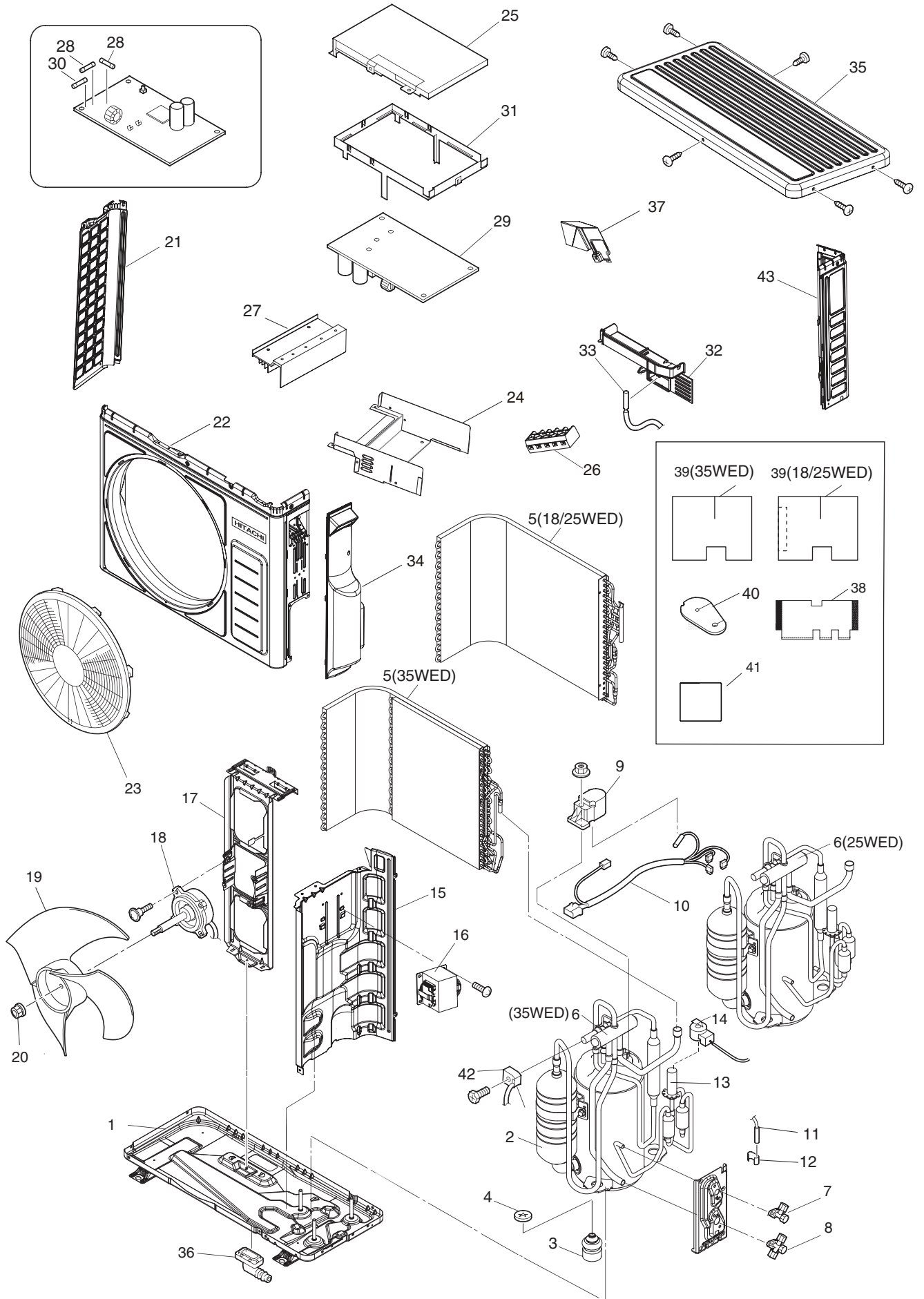
## INDOOR UNIT

### MODEL: RAK-25/35/50PEDC

NO	HHAW PARTS NO			Q' TY/ UNIT	PARTS NAME
	RAK-25PEDC	RAK-35PEDC	RAK-50PEDC		
1	HWRAK-18PED A01			1	CABINET ASS'Y
2	HWRAK-18PED A02			2	VERTICAL AIR DEFLECTOR
3	HWRAS-K10HCG 903			1	FAN MOTOR
4	HWRAK-18PSPA 902			1	TANGENTIAL AIR FLOW FAN
5	HWRAK-18PED A03			1	FAN SUPPORT ASS'Y
6	HWRAK-18PED A04			1	FAN MOTOR SUPPORT-R
7	HWRAK-18PED A05			1	FAN MOTOR SUPPORT-L
8	HWRAK-18PED A06		HWRAK-50PED A01	1	EVAPORATOR ASS'Y
9	HWRAK-18PED A07		HWRAK-50PED A02	1	PIPING ASS'Y
10	HWRAK-18PED A08			1	UPPER COVER
11	HWRAK-18PED A09		HWRAS-25YH4 A15	1	SPRING
12	HWRAS-K10HCG 908			1	TERMINAL BOARD (3P)
13	HWRAK-18PED A10			1	THERMISTOR ASS'Y
14	HWRAK-18PED A11			1	COVER (ELECTRIC)
15	HWRAS-25PEDC A01	HWRAS-35PEDC A01	HWRAS-50PEDC A01	1	P. W. B. (MAIN)
16	HWRAK-18PED A13			1	ELEC-COVER
17	HWRAK-18PED A14			1	INDICATION BOX
18	HWRAK-18PED A15			1	LED-COVER
19	HWRAK-18PED A16			1	FC-GUIDE
20	HWRAK-18PED A17			1	PIPE COVER
21	HWRAK-18PSPA 919			1	DRAIN CAP
22	HWRAS-E10H3 921			1	DRAINAGE PIPE
23	HWRAK-18PED A18			1	STEPPING MOTOR
24	HWRAS-25YH4 A28			2	DEFLECTOR SUPPORT
25	HWRAK-18PED A19			1	HORIZONTAL AIR DEFLECTOR
26	HWRAK-18PED A20			2	AIR FILTER
27	HWRAK-18PED A21			1	FRONT PANEL AS
28	HWRAS-K10HCG 919			1	REMOTE CONTROL ASS'Y
29	HWRAK-18PED A22			1	FRONT COVER
30	HWRAK-18PED A23			1	T-COVER ASS'Y
31	HWRAK-18PED A24			1	H-LABEL
32	HWRAK-18PED A25			1	S-COVER-L
33	HWRAK-18PED A26			1	S-COVER-R
34	HWRAK-18PED A27			1	MOUNTING PLATE
35	HWRAS-E10CXK 014			1	RE-HOLDER

# OUTDOOR UNIT

## MODEL RAC-18/25/35WED





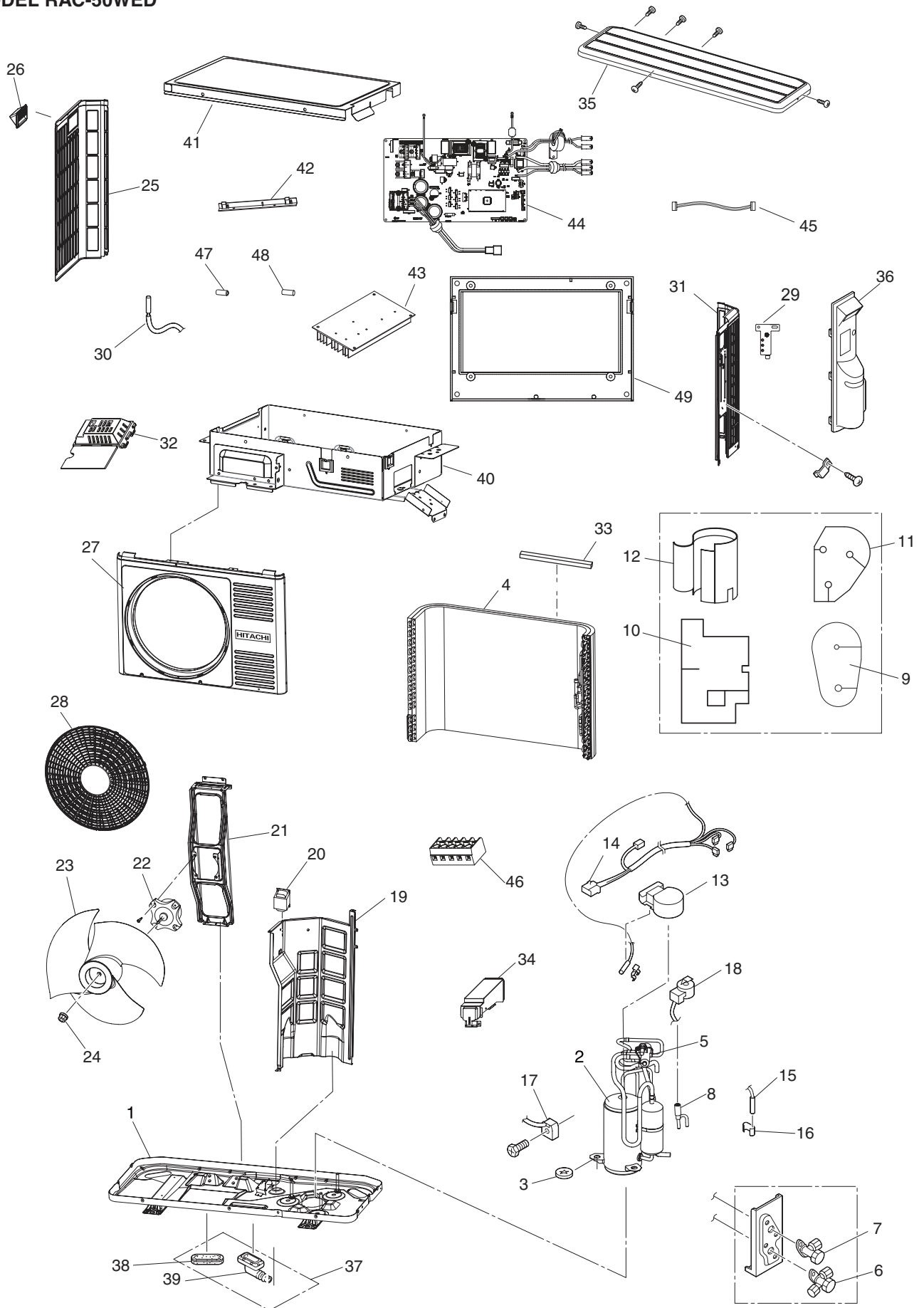
## OUTDOOR UNIT

### MODEL: RAC-18/25/35WED

NO	HHAW PARTS NO			Q' TY/ UNIT	PARTS NAME
	RAC-18WED	RAC-25WED	RAC-35WED		
1	HWRAC-18WED A01			1	BASE
2	HWRAC-18WED A02			1	COMPRESSOR
3	HWRAC-18WED A03			3	COMPRESSOR RUBBER
4	HWRAC-18WEB A04			3	PUSH NUT
5	HWRAC-18WED A04		HWRAC-35WED A01	1	CONDENSER
6	HWRAC-18WED A05		HWRAC-35WED A02	1	REVERSING VALVE
7	HWRAC-50WEA A06			1	2S-VALVE
8	HWRAC-10GH5 A03			1	3S-VALVE
9	HWRAC-18WEB A07			1	O. L. R COVER
10	HWRAC-18WED A06			1	CONNECTING CORD (COMP)
11	HWRAC-D10EX A08			1	THERMISTOR (DEFROST)
12	HWRAC-X18HAK A03			1	THERMISTOR SUPPORT
13	HWRAC-50WED A03			1	ELECTRIC EXPANSION VALVE
14	HWRAC-50WED A07			1	COIL (EXPAN. VALVE)
15	HWRAC-18WEB A33			1	PARTITION
16	HWRAC-18WED A07			1	REACTOR
17	HWRAC-18WED A08		HWRAC-35WED A03	1	FAN MOTOR SUPPORT
18	HWRAC-50WED A10			1	FAN MOTOR
19	HWRAC-18WED A09			1	PROPELLER FAN
20	HWRAC-25YH4 A24			1	NUT (PROPELLER.FAN)
21	HWRAC-18WED A10			1	SIDE COVER (L)
22	HWRAC-18WED A11			1	FRONT COVER
23	HWRAC-18WED A12			1	DISCHARGE GRILL
24	HWRAC-K10HCG A11			1	ELECTRIC PARTS PLATE
25	HWRAC-18WED A13			1	ELECTRIC PARTS COVER
26	HWRAC-50WED A16			1	TERMINAL BOARD (5P)
27	HWRAC-18WEB A20		HWRAC-35WEB A01	1	HEAT SINK
28	HWRAC-50NX2 A52			2	FUSE (3. 15A)
29	HWRAC-18WED A14	HWRAC-25WED A01	HWRAC-35WED A04	1	P. W. B. (MAIN)
30	HWRAC-K10HCG A21			1	FUSE (15A)
31	HWRAC-18WEB A23			1	SUPPORT (P. W. B.)
32	HWRAC-18WED A15			1	COVER (OUTDOOR THERMISTOR)
33	HWRAC-D10EX A17			1	THERMISTOR (OUTDOOR TEMP.)
34	HWRAC-18WED A16			1	EV-COV-ZU
35	HWRAC-18WED A17			1	T-COVERZU
36	HWRAC-25YHA4 A50			1	DRAIN PIPE
37	HWRAC-18WED A18			1	TERMINAL COVER
38	HWRAC-18WED A19			1	SOUND PROOF COVER ASS' Y
39	HWRAC-K10HCG A17		HWRAC-K14HCG A03	1	SOUND PROOF COVER ASS' Y
40	HWRAC-K10HCG A18			1	SOUND PROOF COVER ASS' Y
41	HWRAC-18WEB A30			1	SOUND PROOF COVER ASS' Y
42	HWRAC-50WED A06			1	COIL (REVERSING VALVE)
43	HWRAC-18WED A20			1	SIDE COVER (R)

# OUTDOOR UNIT

## MODEL RAC-50WED



## OUTDOOR UNIT

**MODEL: RAC-50WED**

NO	HHAW PARTS NO	Q' TY/ UNIT	PARTS NAME
	RAC-50WED		
1	HWRAC-50WPC A01	1	BASE
2	HWRAC-50WED A01	1	COMPRESSOR
3	HWRAC-50NX2 A04	3	PUSH NUT
4	HWRAC-50WEC A01	1	CONDENSER
5	HWRAC-50WED A02	1	REVERSING VALVE
6	HWRAC-50WEA A05	1	SERVICE VALVE
7	HWRAC-50WEA A06	1	SERVICE VALVE
8	HWRAC-50WED A03	1	ELECTRIC EXPANSION VALVE
9	HWRAC-50WED A04	1	SOUND PROOF
10	HWRAC-50WPC A04	1	SOUND PROOF
11	HWRAC-50WEC A07	1	SOUND PROOF
12	HWRAC-50WED A05	1	SOUND PROOF
13	HWRAC-50WPC A05	1	O. L. R COVER
14	HWRAC-50WEA A12	1	CONNECTING CORD (COMP)
15	HWRAC-50NX2 A16	1	THERMISTOR (DEFROST)
16	HWRAC-50NX2 A17	1	THERMISTOR SUPPORT
17	HWRAC-50WED A06	1	COIL (REVERSING VALVE)
18	HWRAC-50WED A07	1	COIL (EXPANSION VALVE)
19	HWRAC-50WED A08	1	PARTITION
20	HWRAC-50WED A09	1	REACTOR
21	HWRAC-50WEB A02	1	FAN MOTOR SUPPORT
22	HWRAC-50WED A10	1	FAN MOTOR
23	HWRAC-50WEC A12	1	PROPELLER FAN
24	HWRAC-50NX2 A25	1	NUT (PROPELLER FAN)
25	HWRAC-50NX2 A26	1	SIDE COVER (L)
26	HWRAC-50NX2 A27	1	HANDLE
27	HWRAC-50WED A11	1	FRONT COVER
28	HWRAC-50WEC A14	1	DISCHARGE GRILL
29	HWRAC-50WEA A14	1	EARTH-PLATE
30	HWRAC-E14H3 914	1	THERMISTOR (OUTDOOR TEMPERATURE)
31	HWRAC-50WED A12	1	SIDE COVER (R)
32	HWRAC-18WSPA A24	1	TC-COVER
33	HWRAC-50WEC A15	1	H-SHEET
34	HWRAC-50WEC A16	1	TERMINAL COVER
35	HWRAC-SX18HAK A28	1	TOP COVER
36	HWRAC-50WED A13	1	SERVICE VALVE COVER
37	HWRAC-50NX2 A36	1	BUSH ASSEMBLY
38	HWRAC-50NX2 A37	2	BUSH
39	HWRAC-50NX2 A38	1	DRAIN PIPE
40	HWRAC-50WEC A17	1	ELECTRIC PARTS PLATE
41	HWRAC-50WED A14	1	ELECTRIC PARTS COVER
42	HWRAC-50WEB A07	1	SUPPORT2 (P. W. B.)
43	RAC-1F50KVY014	1	HEAT SINK
44	HWRAC-50WED A15	1	P. W. B. (MAIN)
45	HWRAC-50WEB A11	1	CORD (REACTOR)
46	HWRAC-50WED A16	1	TERMINAL BOARD (5P)
47	HWRAC-50WED A17	1	FUSE (25A)
48	HWRAC-50NX2 A52	2	FUSE (3.15A)
49	HWRAC-50WEB A13	1	SUPPORT1 (P. W. B.)

# HITACHI

---

RAK-18PED/RAC-18WED  
RAK-25PED/RAC-25WED  
RAK-35PED/RAC-35WED  
RAK-50PED/RAC-50WED  
RAK-25PEDC/RAC-25WED  
RAK-35PEDC/RAC-35WED  
RAK-50PEDC/RAC-50WED

JCH-WH NO. 0105E