

HITACHI

SERVICE MANUAL TECHNICAL INFORMATION

FOR SERVICE PERSONNEL ONLY

OUTDOOR UNIT

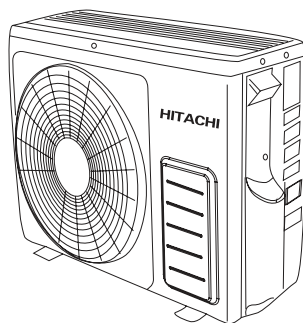

RAC-18WPC
RAC-25WPC

HHAW

NO. 0100E

RAC-18WPC RAC-25WPC

REFER TO THE FOUNDATION MANUAL

CONTENTS

SPECIFICATIONS	6
CONSTRUCTION AND DIMENSIONAL DIAGRAM	8
MAIN PARTS COMPONENT	9
WIRING DIAGRAM	11
BLOCK DIAGRAM	13
REFRIGERATING CYCLE DIAGRAM	14
PROCEDURE FOR DISASSEMBLY AND REASSEMBLY.....	15
DESCRIPTION OF MAIN CIRCUIT OPERATION	16
SERVICE CALL Q & A	24
TROUBLE SHOOTING	28
PARTS LIST AND DIAGRAM	41

SPECIFICATIONS

TYPE	DC INVERTER	
	OUTDOOR UNIT	OUTDOOR UNIT
MODEL	RAC-18WPC	RAC-25WPC
POWER SOURCE	1 PHASE,50Hz,220-230V	1 PHASE,50Hz,220-230V
COOLING	TOTAL INPUT (W)	550 (250 ~ 1010)
	TOTAL AMPERES (A)	3.12-2.97
	CAPACITY (KW) (B.T.U./h)	2.00 (0.90~2.50) 8,530 (3,070~10,580)
HEATING	TOTAL INPUT (W)	580 (250~970)
	TOTAL AMPERES (A)	3.49-3.34
	CAPACITY (KW) (B.T.U./h)	2.50 (0.90~3.20) 11,600 (3,070~15,010)
DIMENSIONS (mm)	W	660(+60)*
	H	530
	D	278(+35)*
NET WEIGHT (Kg)	27.5	27.5

※ After installation

SPECIFICATIONS AND PARTS ARE SUBJECT TO CHANGE FOR IMPROVEMENT

ROOM AIR CONDITIONER

OUTDOOR UNIT

Johnson Controls-Hitachi Air Conditioning Wuhu Co., Ltd.

SAFETY DURING REPAIR WORK

1. In order to disassemble and repair the unit in question, be sure to disconnect the power cord plug from the power outlet before starting the work.

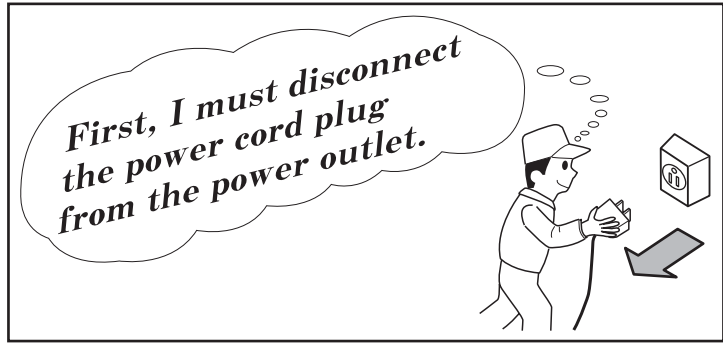

2. If it is necessary to replace any parts, they should be replaced with respective genuine parts for the unit, and the replacement must be effected in correct manner according to the instructions in the Service Manual of the unit.

If the contacts of electrical parts are defective, replace the electrical parts without trying to repair them



3. After completion of repairs, the initial state should be restored.
4. Lead wires should be connected and laid as in the initial state.
5. Modification of the unit by the user himself should absolutely be prohibited.
6. Tools and measuring instruments for use in repairs or inspection should be accurately calibrated in advance.
7. In installing the unit having been repaired, be careful to prevent the occurrence of any accident such as electrical shock, leak of current, or bodily injury due to the drop of any part.
8. To check the insulation of the unit, measure the insulation resistance between the power cord plug and grounding terminal of the unit.
The insulation resistance should be $1M\Omega$ or more as measured by a 500V DC megger.
9. The initial location of installation such as window, floor or the other should be checked for being safe enough to support the repaired unit again.
If it is found not so strong and safe, the unit should be installed at the initial location after reinforced or at a new location.

10. Any inflammable object must not be placed about the location of installation.
11. Check the grounding to see whether it is proper or not, and if it is found improper, connect the grounding terminal to the earth.



WORKING STANDARDS FOR PREVENTING BREAKAGE OF SEMICONDUCTORS

1. Scope

The standards provide for items to be generally observed in carrying and handling semiconductors in relative manufactures during maintenance and handling thereof. (They apply the same to handling of abnormal goods such as rejected goods being returned.)

2. Object parts

- (1) Microcomputer
- (2) Integrated circuits (I.C.)
- (3) Field effective transistor (F.E.T.)
- (4) P.C. boards or the like to which the parts mentioned in (1) and (2) of this paragraph are equipped.

3. Items to be observed in handling

- (1) Use a conductive container for carrying and storing of parts. (Even rejected goods should be handled in the same way.)

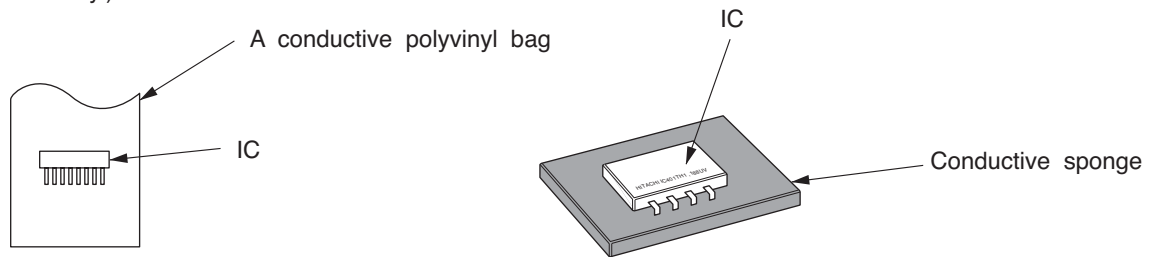

Fig. 1 Conductive container

- (2) When any part is handled uncovered (in counting, packing and the like), the handling person must always use himself as a body earth. (Make yourself a body earth by passing one M ohm earth resistance through a ring or bracelet.)
- (3) Be careful not to touch the parts with your clothing when you hold a part even if a body earth is being taken.
- (4) Be sure to place a part on a metal plate with grounding.
- (5) Be careful not to fail to turn off power when you repair the printed circuit board. At the same time, try to repair the printed circuit board on a grounded metal plate.

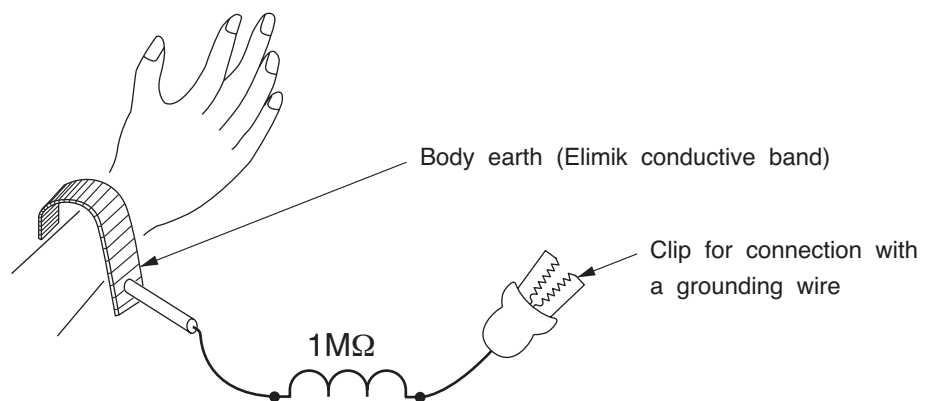

Fig. 2 Body earth

(6) Use a three wire type soldering iron including a grounding wire.

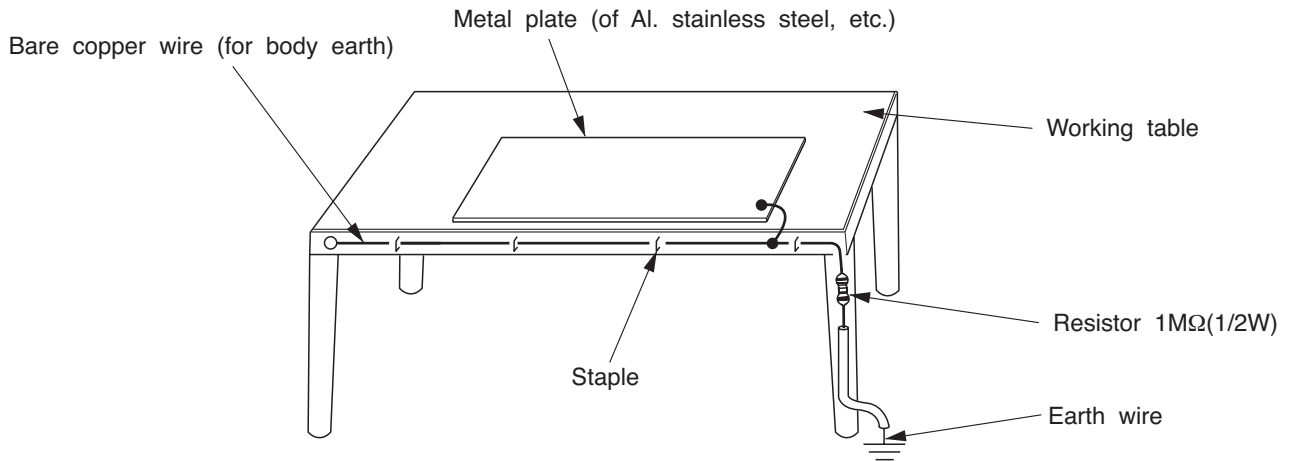

Fig.3 Grounding of the working table

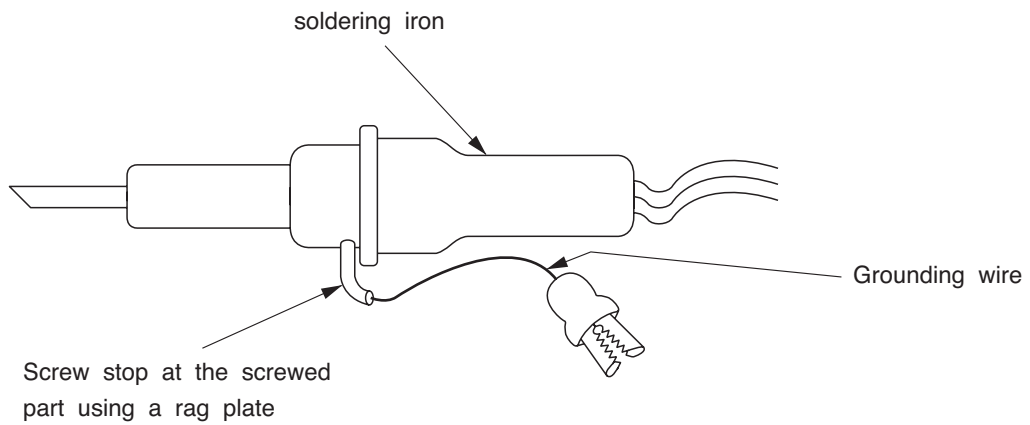

Fig.4 Grounding a solder iron

Use a high insulation mode (100V, 10MΩ or higher) when ordinary iron is to be used.

(7) In checking circuits for maintenance, inspection, or some others, be careful not to have the test probes of the measuring instrument short circuit a load circuit or the like.

 **CAUTION**

1. In quiet or stop operation, slight flowing noise of refrigerant in the refrigerating cycle is heard occasionally, but this noise is not abnormal for the operation.
2. When it thunders near by, it is recommend to stop the operation and turn off the circuit breaker for safety.
3. In the event of power failure, the room air conditioner will restart automatically in the previously selected mode once the power is restored. In the event of power failure during TIMER operation, the room air conditioner will not start automatically. Re-press ON/OFF button after 3 minutes from when the unit off or power recovery.
4. If the room air conditioner is stopped by adjusting thermostat, or misoperation, and re-start in a moment, there is occasion that the cooling and heating operation does not start for 3 minutes, it is not abnormal and this is the result of the operation of IC delay circuit. This IC delay circuit ensures that there is no danger of blowing fuse or damaging parts even if operation is restarted accidentally.
5. This room air conditioner should not be used at the cooling operation when the outside temperature is below -10°C (14°F).
6. This room air conditioner (the reverse cycle) should not be used when the outside temperature is below -15°C (5°F).
If the reverse cycle is used under this condition, the outside heat exchanger is frosted and efficiency falls.
7. When the outside heat exchanger is frosted, the frost is melted by operating the hot gas system, it is not trouble that at this time fan stops and the vapour may rise from the outside heat exchanger.

SPECIFICATIONS

MODEL		RAC-18WPC RAC-25WPC
FAN MOTOR		47W (DC120~380V)
FAN MOTOR CAPACITOR		NO
FAN MOTOR PROTECTOR		NO
COMPRESSOR		ASD084SFNA7JK1
COMPRESSOR MOTOR CAPACITOR		NO
OVERLOAD PROTECTOR		YES(INTERNAL)
OVERHEAT PROTECTOR		YES
FUSE (for MICROPROCESSOR)		15A, 2A, 3A, 3.15A
POWER RELAY		G4A-1A
POWER SWITCH		NO
TEMPORARY SWITCH		NO
SERVICE SWITCH		YES
TRANSFORMER		YES
VARISTOR		450NR, ERZVA431
NOISE SUPPRESSOR		YES
THERMOSTAT		YES(IC)
REMOTE CONTROL SWITCH (LIQUID CRYSTAL)		NO
REFRIGERANT CHARGING VOLUME (Refrigerant R410A)	UNIT	950g
	PIPES (MAX. 20m) (MIN. 3m)	WITHOUT REFRIGERANT BECAUSE COUPLING IS FLARE TYPE.

Figure showing the installation of Indoor and Outdoor unit

MODEL RAC-18WPC
RAC-25WPC

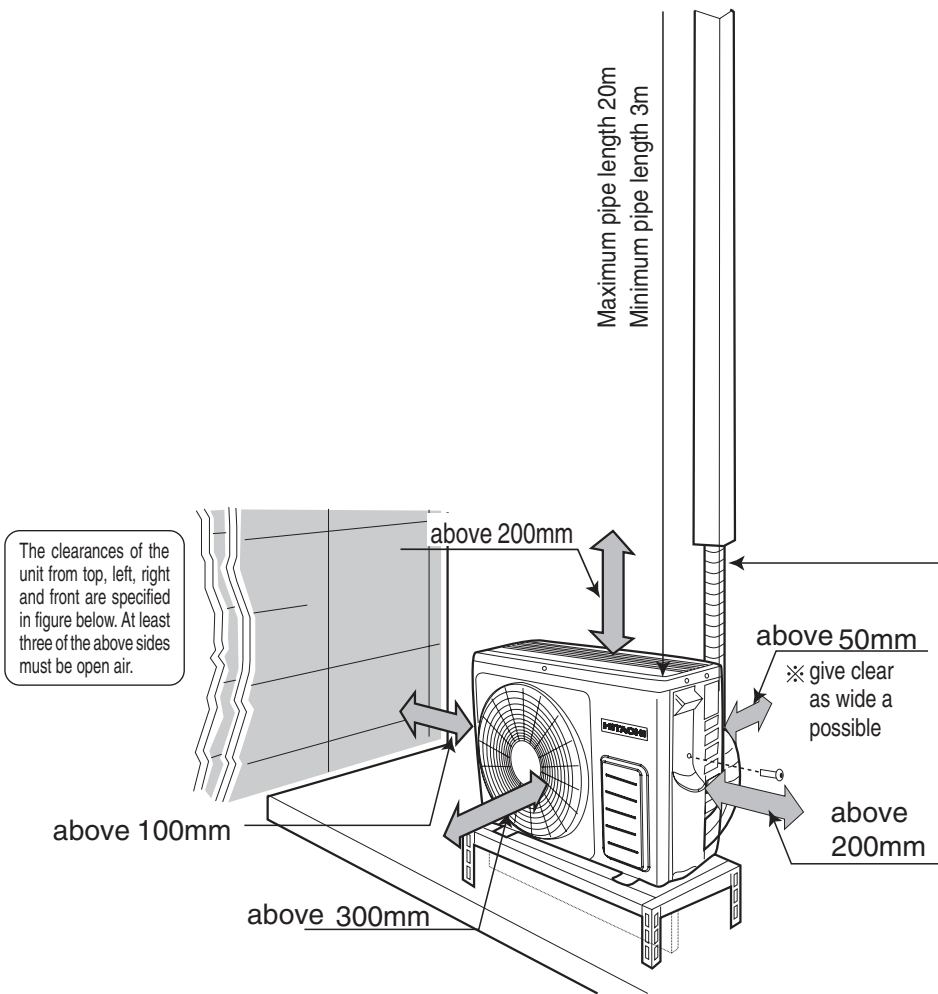

- The refrigerating machine oil is easily affected by moisture. Use caution to prevent water from entering the cycle.
- The difference in height between the indoor and outdoor unit should be kept below 10m.
- The connecting pipe, no matter big or small, should all be insulated with insulation pipe and then wrapped with vinyl tape. (The insulator will deteriorate if it is not wrapped with tape).

The connection of insulated drain hose.
Inner diameter 16mm

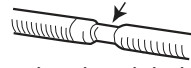

Please use insulated drain hose for the indoor piping (commercial product)

CONSTRUCTION AND DIMENSIONAL DIAGRAM

MODEL RAC-18WPC,RAC-25WPC

OUTDOOR UNIT

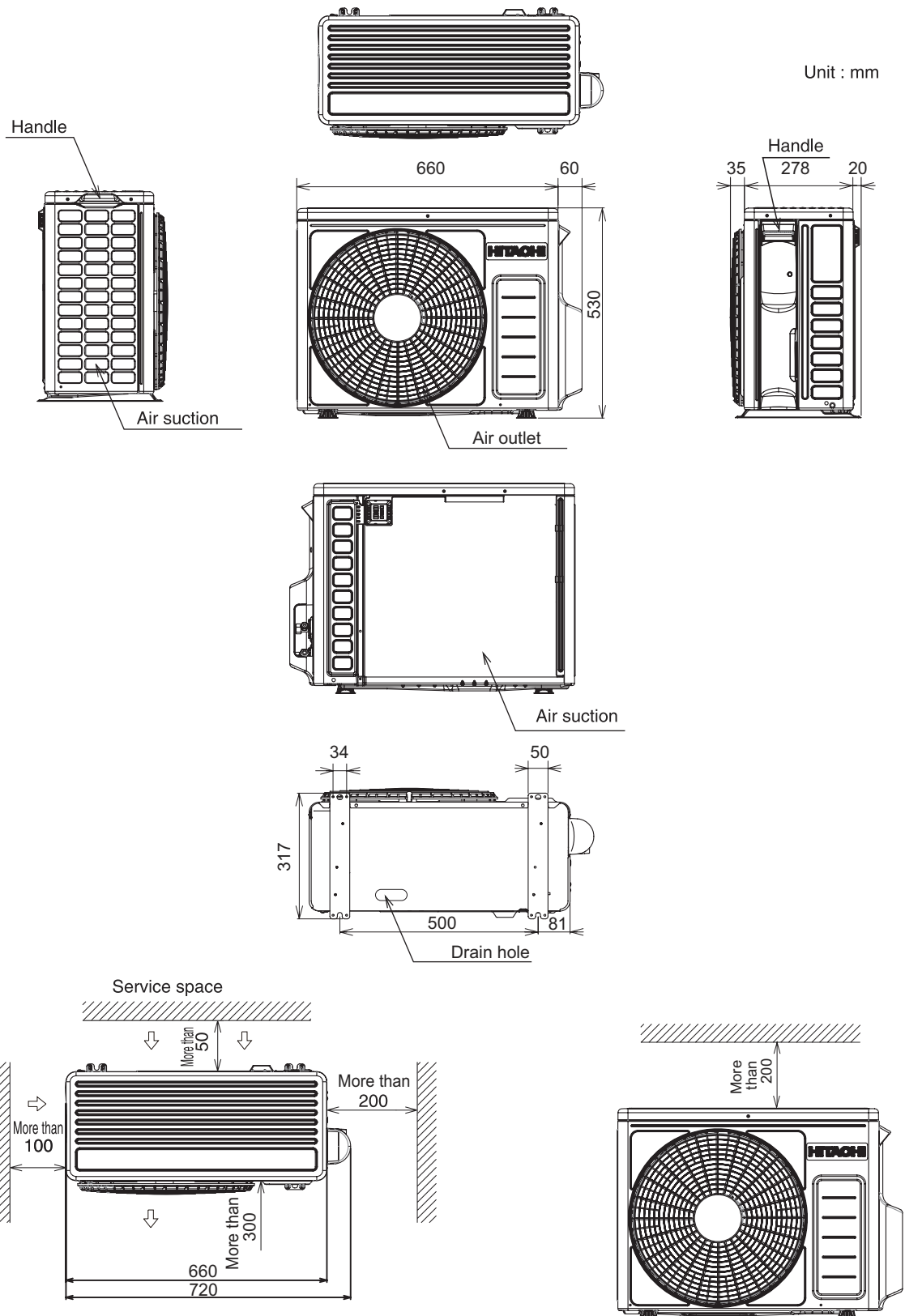

NOTE:

- 1.For outdoor unit installation , allow at least 2 sides of space around the unit ensure ventilation flue.
- 2.The connecting pipe , should all the insulated with insulation pipe.
- 3.Piping length is within 20m.
- 4.Height different of the piping between the indoor unit and outdoor unit should be within 10m.

MAIN PARTS COMPONENT

THERMOSTAT (Room temperature Thermistor)

FAN MOTOR

Fan Motor Specifications

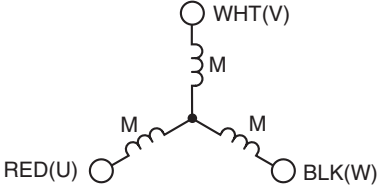
MODEL	RAC-18/25WPC
POWER SOURCE	DC : 120 - 380V
OUTPUT	47W
CONNECTION	 <p>The diagram shows a three-phase motor winding configuration. A central point is connected to three coils, each labeled 'M'. The top coil is connected to terminal WHT(V). The bottom-left coil is connected to terminal RED(U). The bottom-right coil is connected to terminal BLK(W).</p>

BLU : BLUE
 GRY : GRAY
 BLK : BLACK

YEL : YELLOW
 ORN : ORANGE
 PNK : PINK

BRN : BROWN
 GRN : GREEN
 VIO : VIOLET

WHT : WHITE
 RED : RED

MAIN ELECTRIC COMPONENTS FOR OUTDOOR UNIT

NAME	RATING	APPLICABLE MODELS
REACTOR	15 (mH) 250 mΩ MAX (20 °C)	RAC-18/25WPC

COMPRESSOR MOTOR

Compressor Motor Specifications

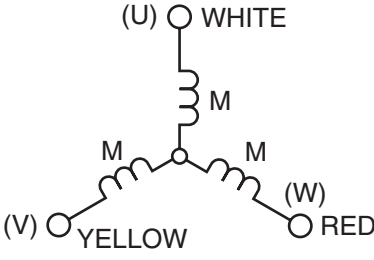
MODEL		RAC-18/25WPC
COMPRESSOR TYPE		ASD084SFNA7JK1
POWER SOURCE		100 - 240 V
CONNECTION		
RESISTANCE VALUE (Ω)	25°C	2M= 0.74
	75°C	2M= 0.88

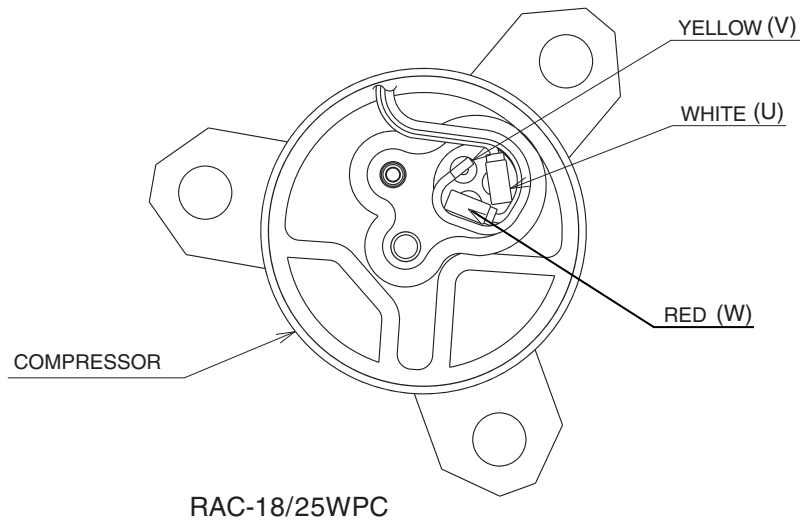

CAUTION

When the refrigerating cycle has been operated for a long time with the capillary tubes clogged or crushed or with too little refrigerant, check the color of the refrigerating machine oil inside the compressor. If the color has been changed conspicuously, replace the compressor.

WIRING DIAGRAM

OUTDOOR UNIT

MODEL RAC-18/25WPC

WIRING DIAGRAM

BLU: BLUE RED: RED
 BLK: BLACK WHT: WHITE
 BRN: BROWN YEL: YELLOW
 GRN: GREEN GRY: GRAY

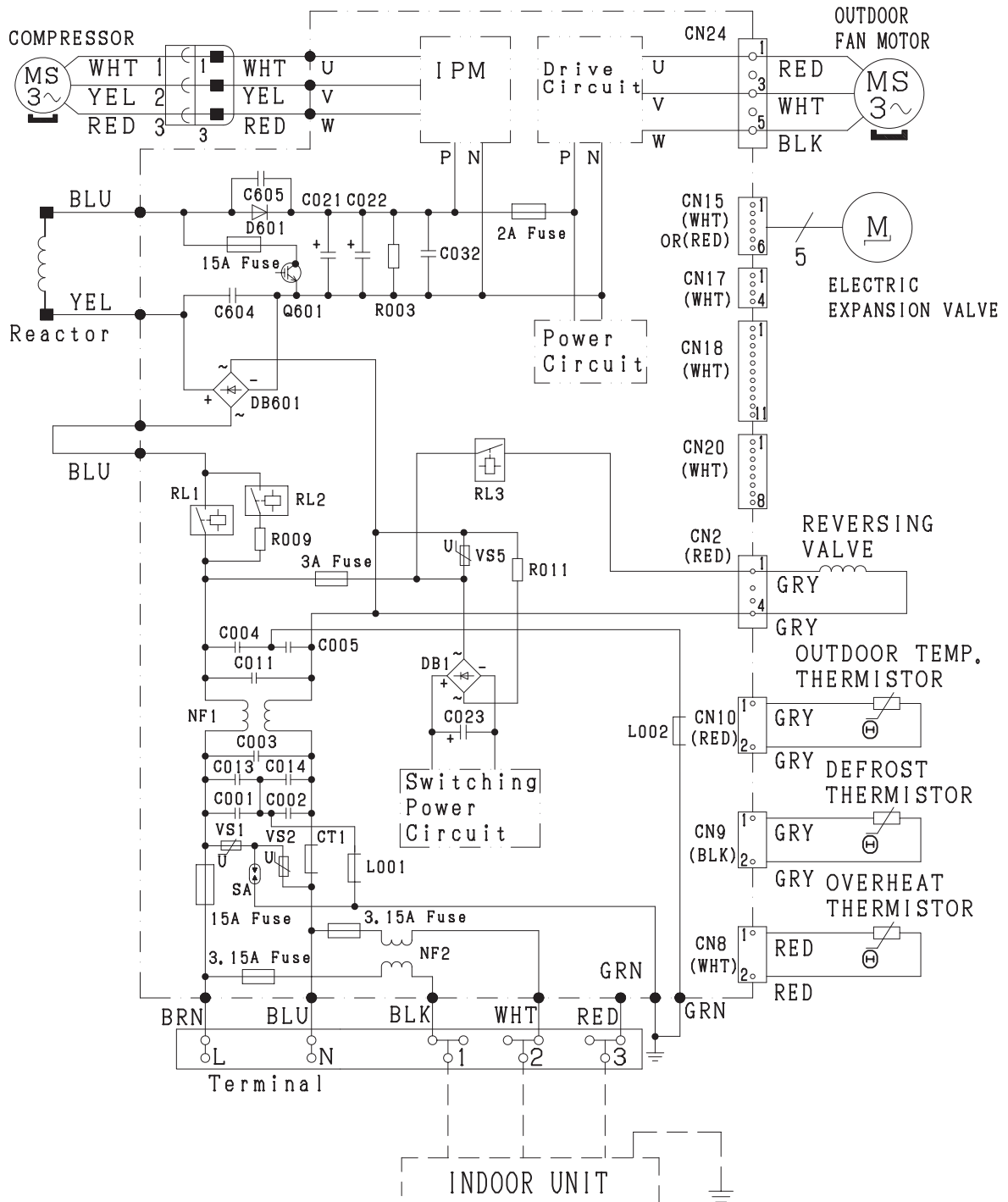

BLOCK DIAGRAM

MODEL RAC-18/25WPC

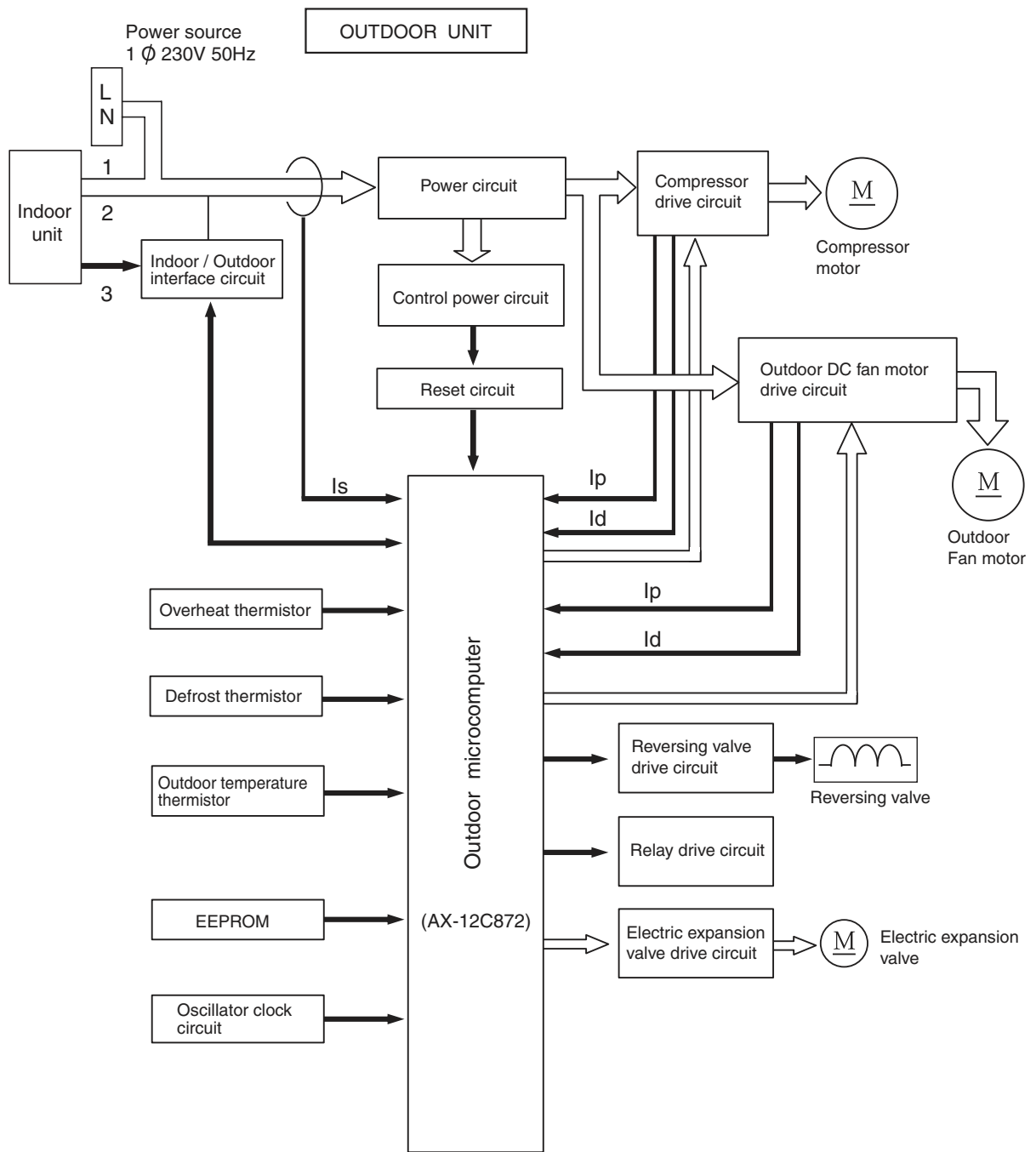

REFRIGERATING CYCLE DIAGRAM

MODEL RAC-18/25WPC

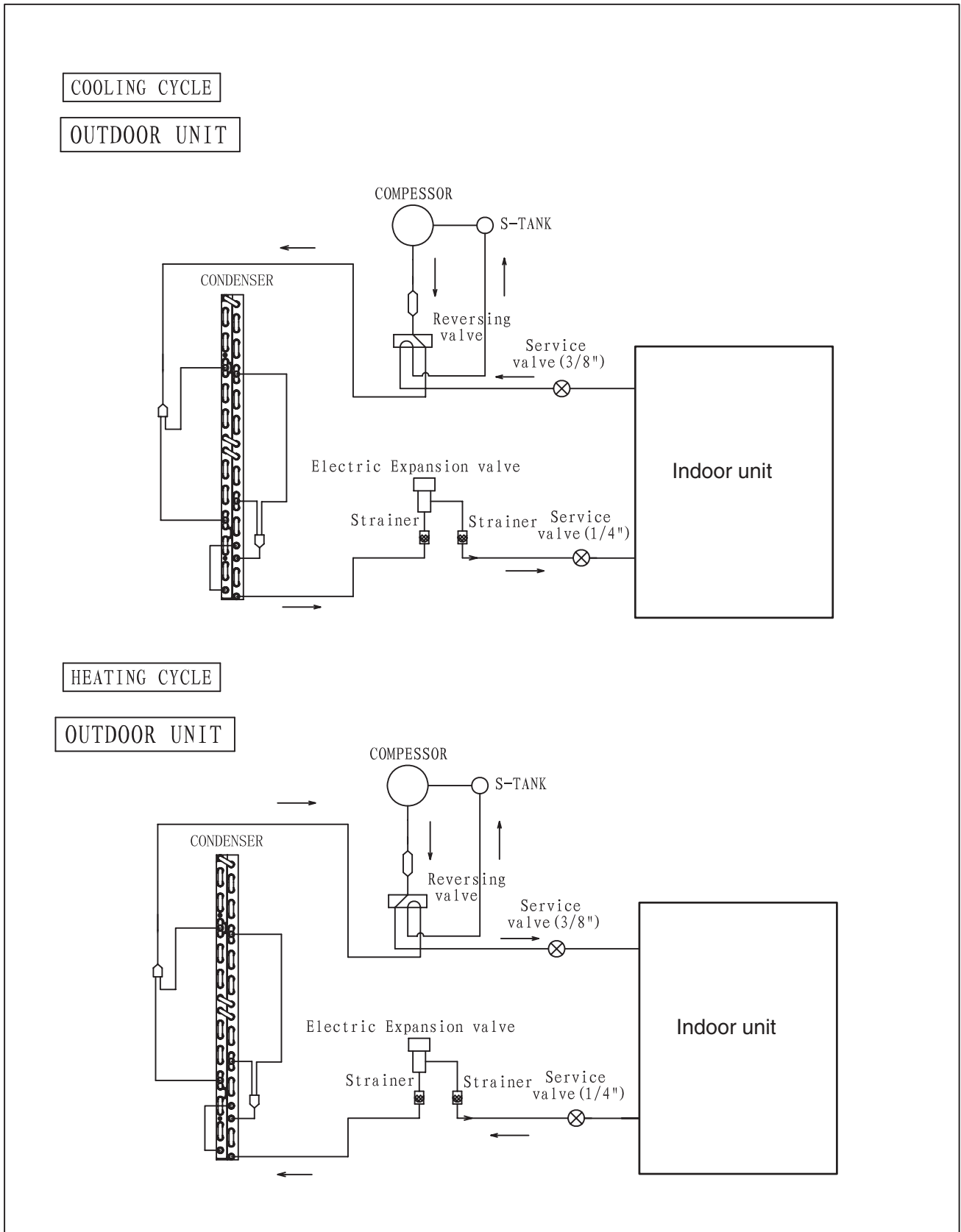

Procedure for Disassembly and Reassembly

<OUTDOOR UNIT> MODEL RAC-18/25WPC

1. Electrical Parts

- (1) Remove the upper cover fixing screws and lift the cover to remove it.
- (2) Remove the service valve cover.
- (3) Remove the terminal plate cover.
- (4) Remove the right side cover.

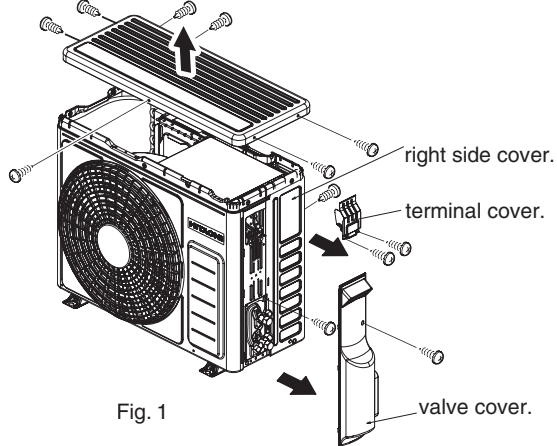

- (5) Remove the electrical box fixing screws and GND wire fixing screw.

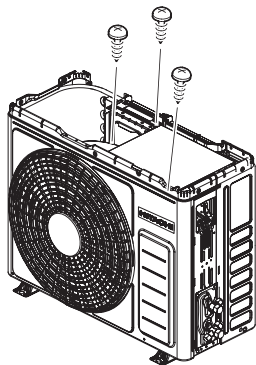

- (6) Remove P lock which binds lead wires.
- (7) Set the electrical box upside down.

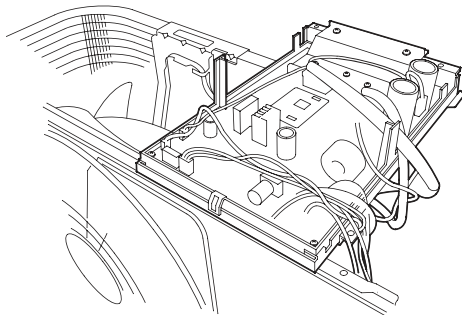

- (8) Remove P.W.B. fixing screws (2 locations) and radiation fin fixing screws (7 locations), and remove the P.W.B. from the support.

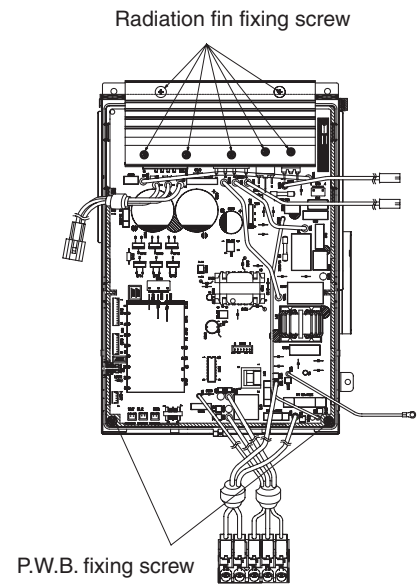

Fig.4

DESCRIPTION OF MAIN CIRCUIT OPERATION

MODEL RAC-18/25WPC

1. Power Circuit

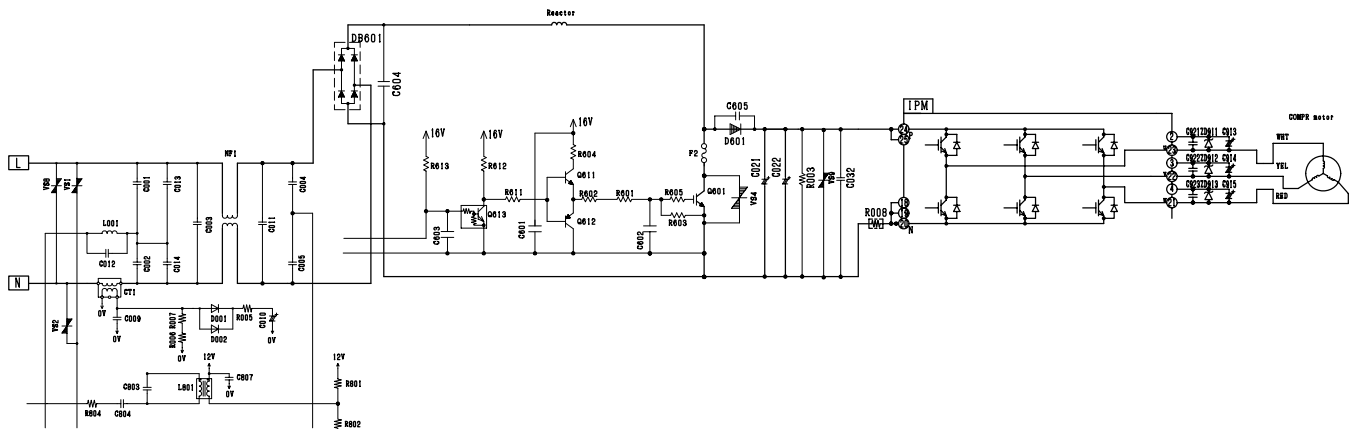

Fig 1-1

※ This circuit full-wave rectifies 230VAC applied between terminals L and N and boosts it to a required voltage with the IPM to create a DC voltage.

The voltage become 300-330V when the compressor is operated.

※ Main parts

(1) Intelligence Power Module (IPM)

A module that constitute by an inverter part.

(2) Diode Stack (DB601)

These rectify the 230VAC from terminal L and N to a DC power supply.

(3) Smoothing capacitors (C021-C022, 375 μ F, 420V)

(4) IGBT to improve efficiency (Q601)

<Reference>

※ In case of Intelligence Power Module malfunction or connection failure immediately after compressor starts, its may stop due to error of [abnormal low speed], [switching failure],[Ip stop] and others.

<Reference>

※ If diode stack (DB601) are faulty, DC voltage may not be generated and the compressor may not operate at all. Also be aware that the 15A fuse might have blown.

※ This smoothes (averages) the voltage rectified by the diode stack.

※ It will improve the efficiency during compressor load become heavy when current flow thru the chopper period of Q601.

2. Power circuit (Low voltage)

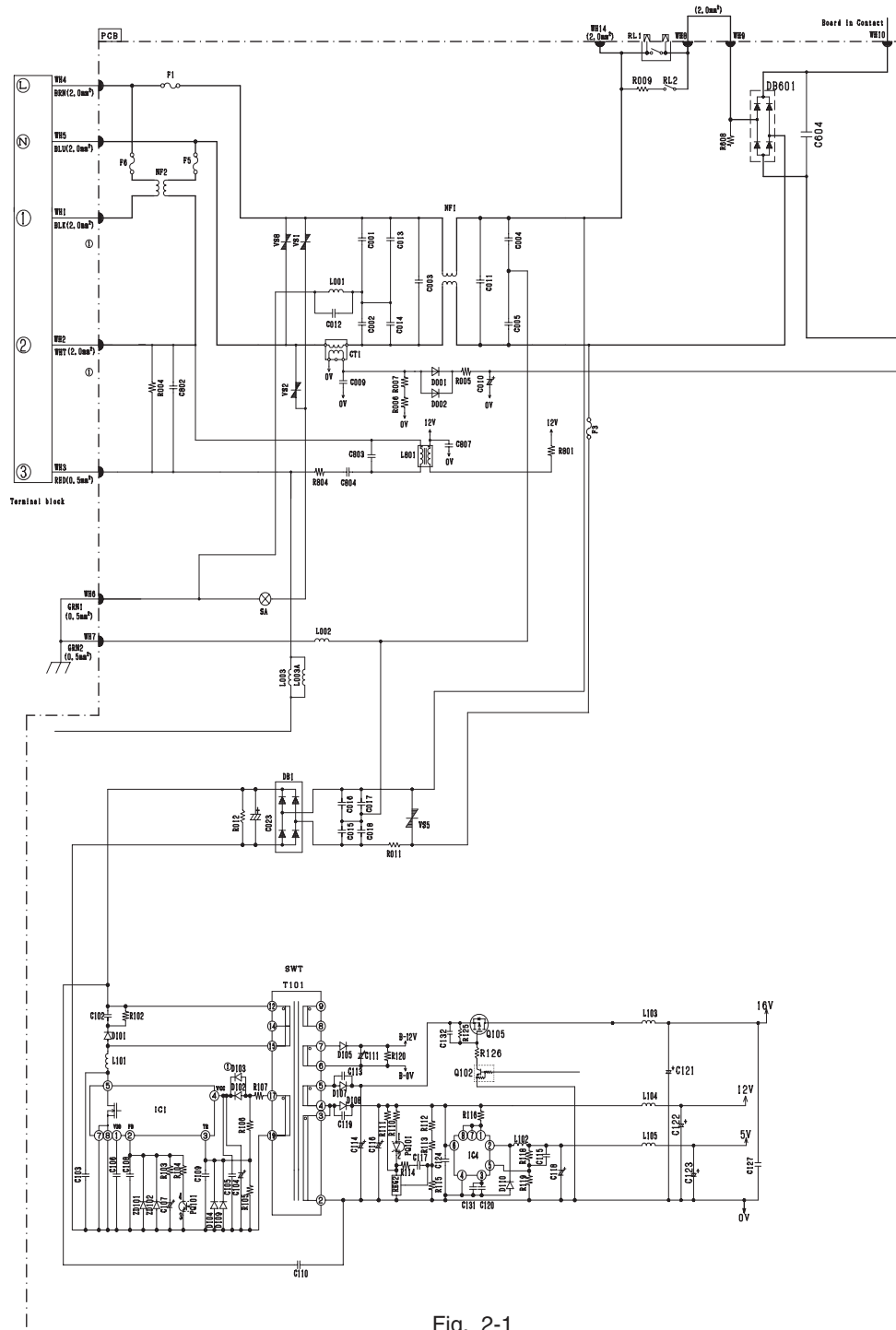

Fig. 2-1

- The 230V AC voltage is rectified to DC voltage (B-12V,16V,12V,5V) pass through switching control IC (IC1), switching transformer.
 - (1) B-12V Power supply for electrical expansion valve.
 - (2) 16V Power supply for IPM driver circuit of compressor and fan motor, IGBT action.
 - (3) 12V Power supply for 4 way valve relay, power relay, inrush current relay, motor current amplification,
 - (4) 5V Power supply for microcomputer, peripheral circuits.

Main parts

(1) C001,C002,C003,C004,C005,C011,C013,C014, NF1

These absorb electrical noise generated during operation of compressor and also absorb external noise entering from power line to protect electronic parts.

(2) Surge Absorber, Varistor1,2,5,8.

These absorb external power surge.

(2) IC4

DC/DC convertor IC (DC12V → DC5V).

3. P.W.B. for power circuit

Voltage specification of power circuit as shown in below table.

<Checking point>

Output	Spec	Main load	Measuring point	Example of possible failure mode.
5V O/P	$5 \pm 0.4V$	Micon, Thermistor	Tester⊕ : L105 (JUMPER) Tester⊖ : D110 (EARTH)	Outdoor not operate, no blinking indication
12V O/P	$12 \pm 0.5V$	Micon, IC2, 3, 4 Relay circuit	Tester⊕ : L104 (JUMPER) Tester⊖ : D110 (EARTH)	Outdoor not operate, no blinking indication
16V O/P	$15.5^{+1.5V}_{-1.0V}$	IPM for Comp IPM for DC fan	Tester⊕ : L103 (JUMPER) Tester⊖ : D110 (EARTH)	Stop : LD301 3, 4 or 12 times blinking
B-12V O/P	$13^{+2.5V}_{-1.0V}$	Expansion valve	Tester⊕ : R120 (B-12V) Tester⊖ : R120 (B-0V)	Stop : LD301 5 times blinking

※ Power circuit for P.W.B. can consider normal if the result is satisfied with above specification.

4.Reversing valve control circuit

This model reversing valve control used to control the relay ON/OFF of the reversing valve, and also control the coil of the reversing valve ON/OFF.

The relay ON/OFF has different type when in the different operation mode.

You can see each operation mode as follows. If the reversing valve not connected or all the condition not the same as follow, it may be something wrong with the reversing valve circuit.

operation mode \ Point		micon ②8 pin - 0V	HIC ③4 pin - 0V	CN2 ①- CN2 ④
		Cooling	Usual cooling	Hi
Heating	Usual heating	Lo	12V	0V
	Defrost	Hi	0V	AC230V

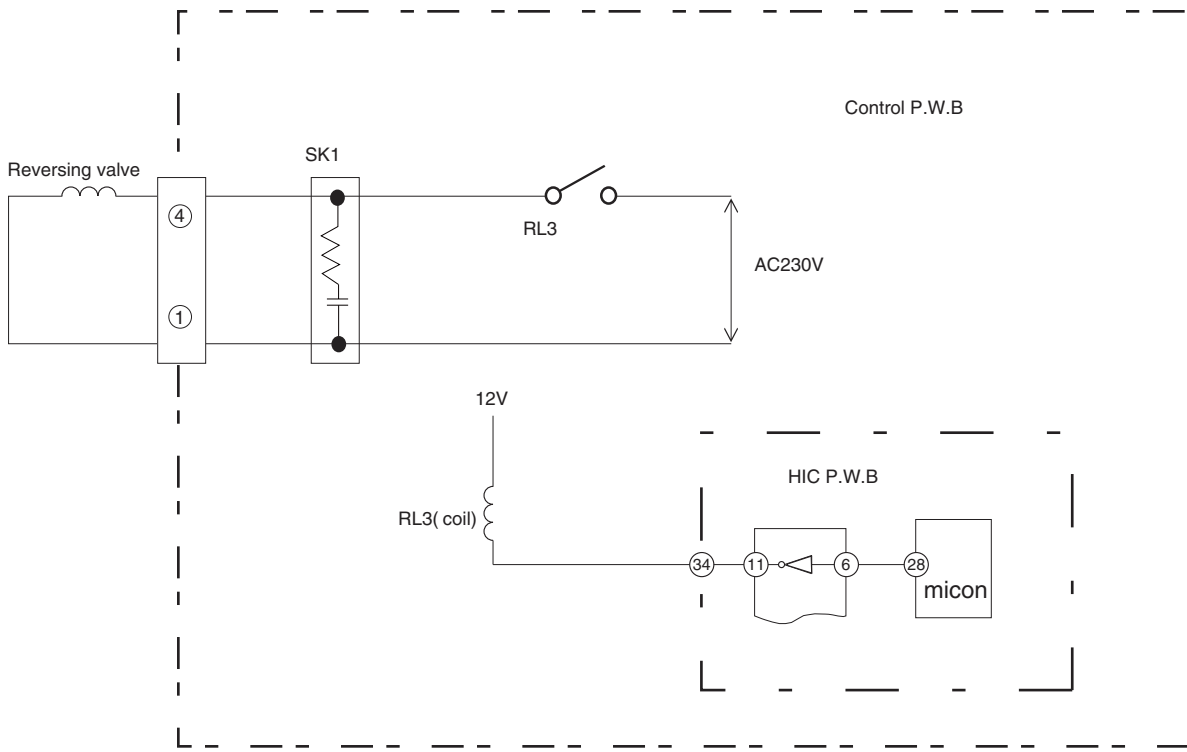

Fig.4-1

5. Temperature Detection Circuit

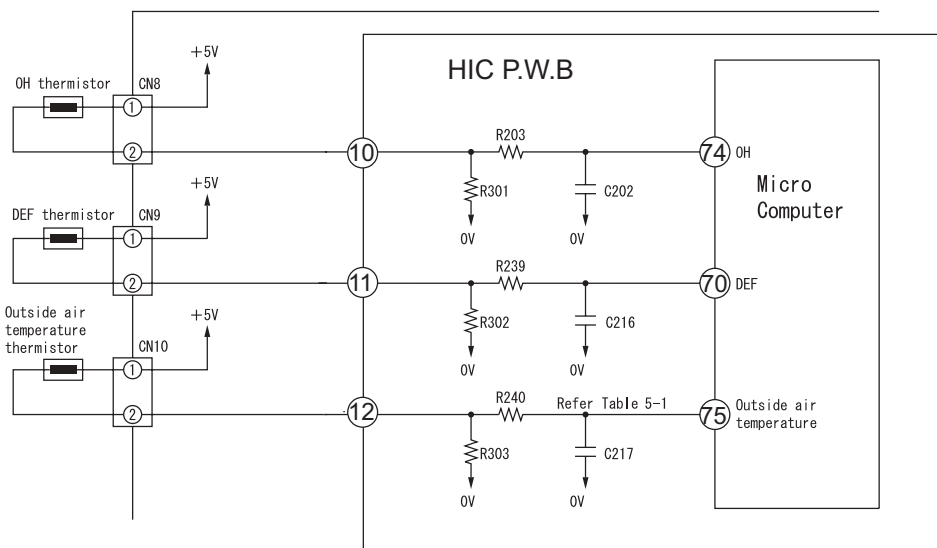

Fig. 5-1

- OH thermistor circuit detect the temperature at the surface of compressor head, DEF thermistor circuit detect the defrosting operation temperature.
 - A thermistor is a negative resistor element which has characteristics that the higher(lower) the temperature, the lower(higher) the resistance.
 - When the compressor is heated, the resistance of the OH thermistor becomes low and $\oplus 5V$ is divided by OH thermistor and R301 and the voltage at pin ⑦④ of microcomputer.
 - Compare the voltage at microcomputer pin ⑦④ and setting value stored inside. If the value exceed the set value, microcomputer will judge that the compressor is overheated and stop the operation.
 - When frost is formed on the outdoor heat exchanger, the temperature at the exchanger drops abruptly. Therefore the resistance of the DEF thermistor becomes high and the voltage at pin ⑦① of micro computer drops. If this voltage becomes lower than the set value stored inside, microcomputer will enter the defrost control.
 - During defrost operation, the microcomputer will transfer the defrosting condition command to indoor unit via SDO pin of interface of IF transmission output.
 - The microcomputer read the outdoor temperature by Outside Air thermistor and transfer it to the indoor unit, thus controlling the compressor rotation speed according to the set value in the EEPROM of indoor unit and switching the operation mode (outdoor fan on/off etc.) to DRY mode.
- Below table show the typical values of outdoor temperature in relation to the voltage.

Table 5-1

Outside Air Temperature (°C)	-10	0	10	20	30	40
Voltage at both side of R303 (V)	1.19	1.69	2.23	2.75	3.22	3.62

<Reference>

When the thermistor is open, open condition or disconnect, microcomputer pin ⑦①⑦④⑦⑤ are approx. 0V;

When thermistor is shorted, they are approx. 5V and LD301 will blink 7 times.

However, an error is detected when only the OH thermistor is shorted and will enter blinking mode after 12 minutes start the compressor operation.

6. Electric expansion valve circuit

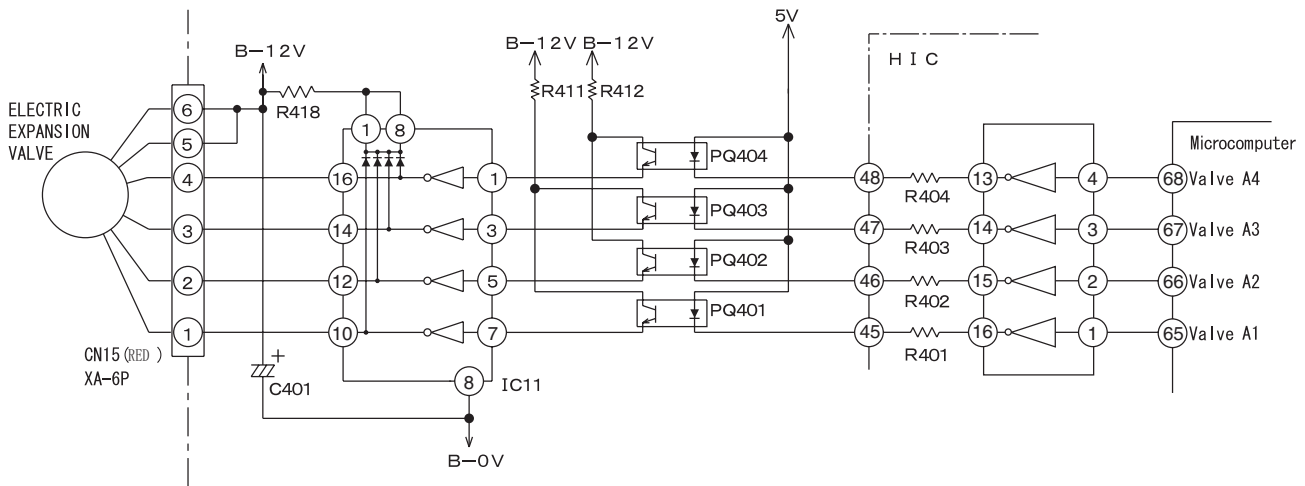

Fig. 6-1

- The electric expansion valve is driven by DC12V. Power is supplied to 1 or 2 phases of 4-phase winding to switch magnetic pole of winding in order to control the opening degree.
- Relationship between power switching direction of phase and open/close direction is shown below. When power is supplied, voltages at pins ④ to ① of CN15 are about 0.9V and 12V when no power is supplied. When power is reset, initial operation is performed for 10 or 20 seconds. During initial operation, measure all voltages at pin ④ to ① of CN15 by using a multimeter. If there is any pin with voltage that has not changed from 0.9V or 12V, expansion valve or microcomputer is broken.
- Fig. 6-2 shows logic waveform when expansion valve is operating.

Table 6-1

CN15 pin no.	Wire	Drive status							
		1	2	3	4	5	6	7	8
①	WHT	ON	ON	OFF	OFF	OFF	OFF	OFF	ON
②	YEL	OFF	ON	ON	ON	OFF	OFF	OFF	OFF
③	ORG	OFF	OFF	OFF	ON	ON	ON	OFF	OFF
④	BLU	OFF	OFF	OFF	OFF	OFF	ON	ON	ON

Operation mode
 1→2→3→4→5→6→7→8 VALVE CLOSE
 8→7→6→5→4→3→2→1 VALVE OPEN

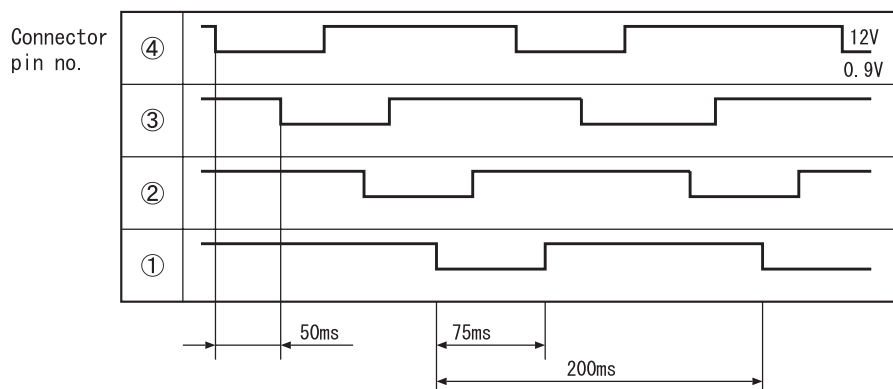

Fig. 6-2

With expansion valve control, opening degree is adjusted to stabilize target temperature by detecting compressor head temperature. The period of control is about once per 20 seconds and output a few pulse.

7. Outdoor DC fan motor control circuit

- This model is built with DC fan motor control circuit inside outdoor electrical unit.

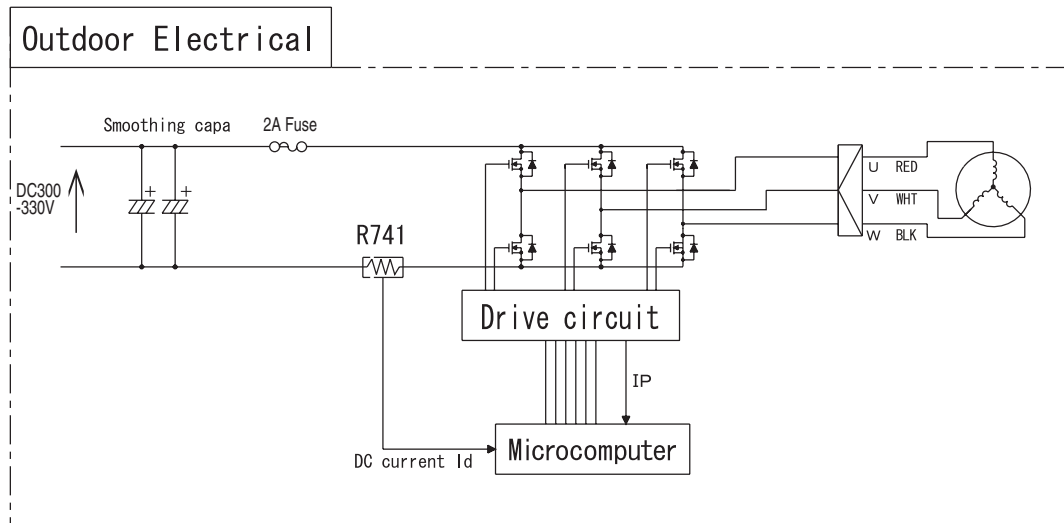

Fig 7-1

This DC fan motor is control by outdoor microcomputer that follow the operating instruction received from indoor microcomputer. The DC current that flow from R741 will presume actual operation speed and control the rotation to follow the operating instruction. Based on this DC current it will detect a over current and other fan motor failure.

(1) Fan motor speed controller during starting

Due to the interference of strong wind etc., operation movement is changed based on fan direction and rotation speed as shown below during starting of operation.

In addition, the fair wind is define as wind that blow to outside direction using Mouth Ring part. At strong and contrary wind ... The rotational speed is not controlled as to protect the equipment and fan will rotate reversely depend on the wind. Automatically start when wind condition become weak.

At contrary wind ... The rotational speed is controlled in fair wind direction after it slowly reduce the speed and finally stop.

At fair wind ... The rotational speed is controlled as it is.

At strong fair wind ... The rotational speed is not controlled as to protect the equipment and fan will rotate reversely depend on the wind. Automatically start when wind condition become weak.

(2) Fan motor speed controller during unit operating

There is a case where fan rpm is reducing during rotating caused by interference of strong wind. If this condition continue in long period, fan will stop rotating. (LD301 : 11 times blinking)
The unit will restart according to control as per during start (1).

(3) Method of confirming self diagnosis LD301 lamp : 12 times blinking

If the unit stop and LD301 on the pwb blinking 12 times [fan lock stop is detected], follow below steps to confirm it.

1. Fan lock stop is detected when something has disturb the fan rotation by inserting material into propeller fan or ice has growing inside outdoor unit caused by snow.
Remove it if found something is bloking the fan.
2. Confirmed that CN24 connector is securely inserted. Fan lock stop is detected also when connector is not properly inserted. Please securely insert if found any disconnection.
3. Fan lock stop also can be detected where strong wind blown surrounding the unit.
Please confirm after restart the unit. (It may take few minutes to operate the compressor)
It is not a malfunction of electrical unit or fan motor if the unit run continuesly after restart the unit.
4. Check fan motor condition as below procedure.

[Checking Fan Motor] procedure

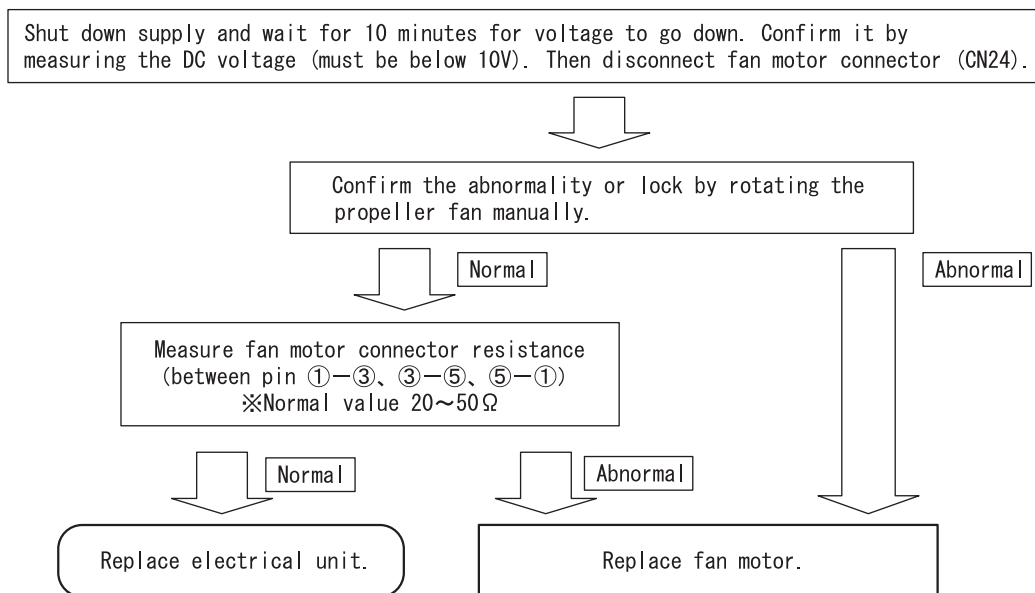

5. Reconnect again fan motor connector (CN24).

※Please confirm above checking procedure if found 2Afuse blown.

If fan motor is broken, replace both electrical unit and fan motor.

Caution

※Beware of electric shock due to high voltage when conducting an operation check.

Power supply for DC fan motor and compressor is common (DC300-330V).

SERVICE CALL Q&A

Cooling operation

Q1 The compressor sometimes stops during cooling.



A1 Check if the heat exchanger of the indoor unit is covered with dew. Wait for 3 to 4 minutes until the dew disappears.

Cooling when the room temperature is low may cause the heat exchanger of the indoor unit to gather dew.

Dehumidification

Q1 The indoor unit produces a noise that goes "shaaahhh" during dehumidification.



A1 That is a noise produced by refrigerant flowing through the pipe.

Q2 Cold air comes out during a dehumidifying operation.



A2 To improve the dehumidification efficiency performs quiet fan operation. Therefore the air is cold and it is not a malfunction.

Q3 The operation does not stop even by setting the temperature higher than room temperature on the remote controller.



A3 It sets to perform dehumidifying operation by setting the temperature slightly lower than remote controller setting.

Heating operation

Q1 The product sometimes fails to produce a wind during heating.



A1 Defrosting is in progress. Wait 5 to 10 minutes until the dew on the outdoor unit disappears.

Q2 The product begins with a slight wind during heating even though set to "strong wind" or "weak wind."



A2 At the first of the heating, the product will run for 30 seconds with a slight wind. When set to strong wind, the product will begin with a slight wind operation, producing a weak wind for 30 seconds, and then switch to strong wind.

Q3 The product stops during heating even though it is set to "30°C."



A3 When heating is conducted despite the high outdoor temperature, the product may stop to protect its equipment.

Auto-fresh defrost

Q1 During heating, I turned off the product by using the START/STOP button. But the "operation lamp" is blinking and the outdoor unit is running.



A1 The "auto-fresh defrost" should be working. When stopped, the product will check its outdoor unit for dew and, if there is any dew, conduct defrosting and then stop operating.

Automatic operation

Q1 During an automatic run, switching the wind speed selector will not change the wind speed.



A1 The product will switch automatically to automatic wind speed. You cannot select strong or weak wind by remote control but you can select wind and quiet.

Q2 How is the automatic operation mode determined?



A2 According to the room temperature, heating or cooling operation is automatically selected. Refer to the basic operation section.

Common, etc.

Q1 In "automatic wind speed" mode, the indoor fan changes from strong wind to weak wind to slight wind.



A1 This does not abnormal. It is because the cold wind prevention is working.

In wind speed "automatic" mode, the product will sense the heat exchange temperature and, when the temperature goes down, the product will automatically switch to strong wind to weak wind to slight wind.

Q2 At operation startup, the outdoor unit becomes noisy.



A2 At operation startup, the product will set the rotation speed of the compressor to full power and increase its heating and cooling capacity, resulting in a slightly higher noise level. This is not a sign of a breakdown.

Q3 The outdoor unit sometimes changes in its noise.



A3 The difference between the thermometer temperature setting and room temperature will change the rotation speed of the compressor. This is not a sign of a breakdown.

Q4 There is a difference between the temperature setting and room temperature in room temperature control.



A4 The room structure, air stream, or other factor may cause a gap between the room temperature setting and actual room temperature. If there is any difference between the setting and the room temperature, adjust the temperature setting to match the living space to a comfortable temperature.

Q5 The product will not produce wind right after startup.



A5 After turning ON the power switch or breaker, setting the product to heating or dehumidification will activate a preliminary operation for 1 minute. At that time, heating will cause the operation lamp to blink. This is not a sign of a breakdown.

Q6 I performed internal cleaning, but didn't succeed in controlling the mold in the room.



A6 Internal cleaning will clean the inside of the indoor unit of the air-conditioner, thereby controlling mold generation. This will not control the mold in the room.

Wireless remote control

Q1 The timer will not become set.



A1 Have you set the product to the current time? The timer cannot be set unless it is set to the current time.

Q2 The current time display will disappear at once.



A2 The current time disappears 10 seconds later. The timer set display is given priority.

When set to the current time setting, the reading blinks for about 3 minutes.

Q3 I made a timer "reservation". But the time setting has disappeared.







A3 Is the time not past the reserved time? The set time disappears when the current time reaches the reserved time.

Q4 I tried to set the "sleep" timer while the ON timer is reserved. But it will not set itself to a desired time.



A4 The time set in the "sleep" timer can be set with a time up to the time set with the ON timer. If the end time of the "sleep" timer is past the time set with the ON timer, you cannot make that setting.

<p>Q5 I set the "sleep" timer during operation. But</p> <ul style="list-style-type: none"> ① the indoor fan will not run (it will not produce wind) ② wind intensity will not change. 		<p>A5</p> <ul style="list-style-type: none"> ① This occurs when the room temperature and humidity have reached their settings during dehumidification and the air-conditioner is in a pause. The product will begin again to run within about 3 minutes. ② The product will run with the wind speed set to a "quiet" state.
<p>Q6 I tried to change the setting with the "room temperature" button of the remote control unit in vain.</p>		<p>A6 You cannot make this setting when the product is in "air purification" mode. Moreover, you cannot set the product to a desired setting when quick laundry or dew control is being performed with the "auto" or "quick dehumidification" button.</p>
<p>Q7 The temperature setting field on the remote control unit displays $+f^{\circ}\text{C}$ or $-f^{\circ}\text{C}$.</p>		<p>A7 The product will give a display when you operate the product in "auto" using the operation switch button. This can be controlled within the range of $\pm 3^{\circ}\text{C}$.</p> <p>The product will display $+f^{\circ}\text{C}$ if the temperature is $f^{\circ}\text{C}$ higher than the room temperature in automatic setting.</p> <p>The product will display $-f^{\circ}\text{C}$ if the temperature is $f^{\circ}\text{C}$ lower than the room temperature in automatic setting.</p>
<p>Q8 The remote control unit will give no display in response to a push of the "vertical vane" button.</p>		<p>A8 The remote control unit displays nothing.</p>

TROUBLE SHOOTING

MODEL RAC-18/25WPC

Inspection instructions



Warning

Note that the 0 V line of the outdoor electrical parts and the primary power circuit of the indoor electrical parts have voltages to ground as illustrated in the right-hand figure.



RAC-18/25WPC

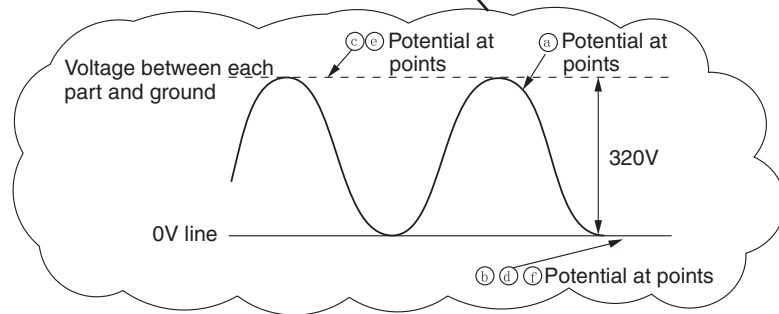
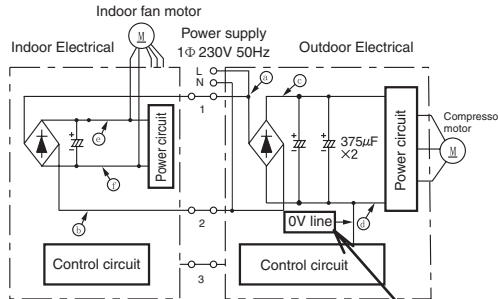

Warning

When conducting a check with an oscilloscope or something similar, do not ground the oscilloscope. Note that the oscilloscope will be subjected to voltages as illustrated in the figure above.

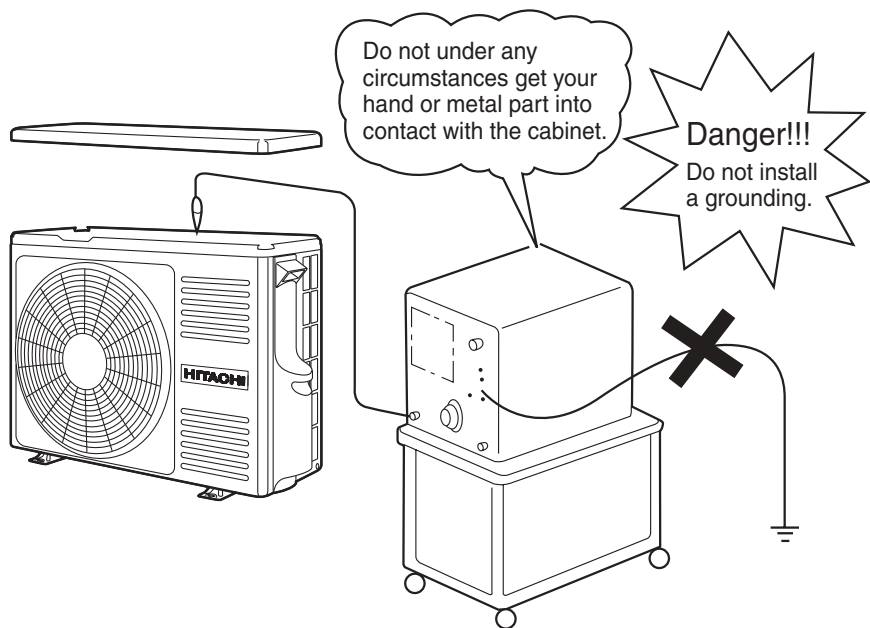

DISCHARGE, PROCEDURE AND POWER SHUT OFF METHOD FOR POWER CIRCUIT



WARNING



Caution

- Voltage of about 350 V is charged between the terminal of smoothing capacitors.
- During continuity check for each circuit part of the outdoor unit, be sure to discharge the smoothing capacitors.

Discharge Procedure

1. Turn off the power.
2. After power is turned off, wait for 10 minutes or more. Then, remove electrical parts cover and apply soldering iron of 30 to 75 W for 15 seconds or more to IPM(24) and IPM(20) terminals on the main P.W.B. as shown in the figure below, in order to discharge voltage in smoothing capacitor.

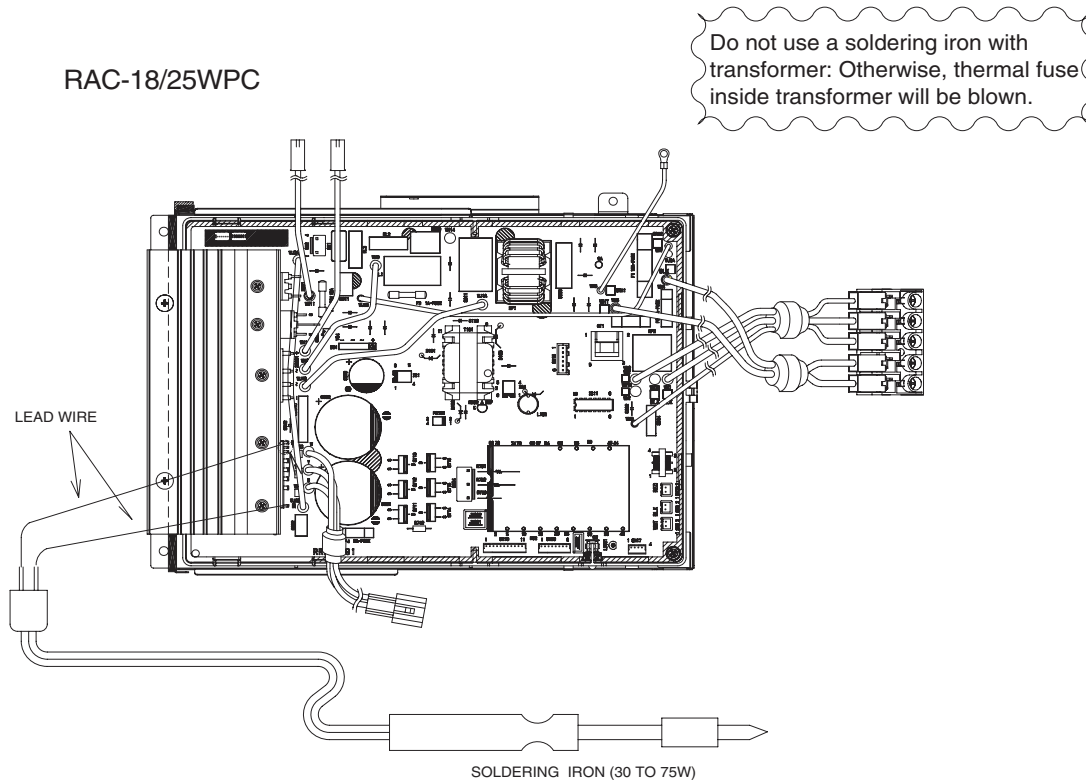

Other instructions

(1) Detaching and reattaching the receptacles for tab terminal

All the receptacles for connecting tab terminals are with a locking mechanism. Forcibly pulling any such receptacle without unlocking it will destroy it. Be on guard.

When reconnecting it, insert it securely all the way home.

· Receptacle types and how to unlock them

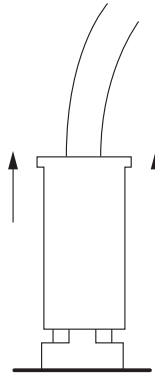

Vertical (with a resin case)

Hold the resin case and pull it out.

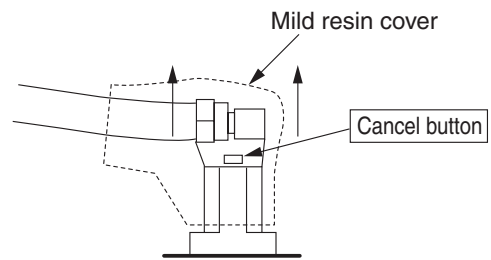

Horizontal (with a mild resin cover)

Hold the cancel button down on the mild resin cover while pulling it out.

(2) Detaching and reattaching the board connector

The product comes equipped with many board connectors provided with lock mechanism. Forcibly pulling any such part without unlocking it will destroy it. Be on guard. When reconnecting it, insert it securely all the way home.

Pinch the locking mechanism with your fingers and pull it out unlocked.

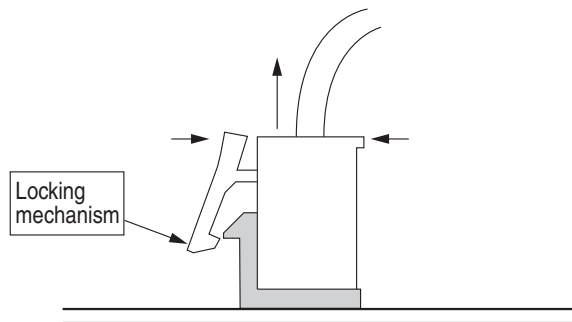

(3) Do not detach or reattach the connectors while energized

Do not under any circumstances detach or reattach the connectors while energized. That would destroy the board components and fan motor. For both the indoor and outdoor boards, ensure that the smoothing capacitor has discharged its electricity fully before you do your work.

No.	Function	Description
1	[Display on the outdoor unit side]	<ul style="list-style-type: none"> · The failure mode detected on the outdoor unit side is displayed by blinking the "LD301". Detecting a failure will stop the outdoor unit and keep blinking the LD301 until it is restarted. (The communication error will persist until the communication is reestablished.)
2	Self-diagnosis memory	<ul style="list-style-type: none"> · The failure modes detected on the indoor and outdoor unit sides are stored in the nonvolatile memory of the indoor unit and can be read later on. (The memory will remain even after power-off.) · The failure modes detected on the outdoor unit side are written in memory every time any such mode occurs. The failure mode can therefore be detected on the indoor unit side without waiting for the retry frequency to reach the display of the indoor unit lamp. Moreover, the normal self-diagnosis display function which rarely occurs will store and display failure modes that do not end up displaying the indoor unit lamp. (Any such mode may be unable to be stored if indoor or outdoor communications is in a failure.) · The product stores 5 last-stored failure modes. · There is a function for deleting memory. Once you clear the memory and run the product for several days, you can read the failure modes and check them, thereby detecting the less frequent failure phenomena. · Failure modes can be checked by both the blinking of the lamp of the indoor unit and the display of the remote control liquid crystal display.

※The "self-diagnosis function of the communication circuit" available in our conventional models is now incorporated as part of the normal self-diagnosis function. In the case of a failure in the communication circuit, you do not have to conduct a special operation and the operations can be automatically divided into 3 blinking operations and 12 blinking operations of the timer lamp. However, a strong external noise may have resulted in 12 times of blinking.

SELF-DIAGNOSIS LIGHTING MODE

MODEL RAC-18/25WPC

⚠ DANGER (DC350V)

CUT THE POWER SOURCE AND WAIT MORE THAN 10 MINUTES BEFORE SERVICE WORK.

CONFIRM THE DC VOLTAGE AT THE MEASURING POINT SHOWN IN BELOW FIGURE MUST BE LESS THAN 10V.

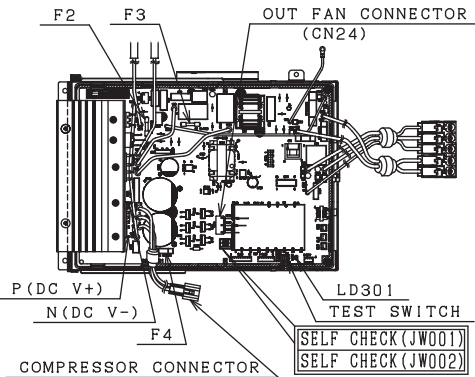

OTHERS CHECK POINTS

- DIAGNOSIS FOR [REVERSING VALVE OPERATION ERROR];
 ⇒ CHECK REVERSING VALVE WIRE CONNECTION EITHER WIRE BROKEN OR NOT, IF OK CHECK 3, 15A FUSE, IF BROKEN REPLACE FUSE.
 2. WHEN DISPLAY THE COMMUNICATION ERROR OR THE OUTDOOR DO NOT RUN AT ALL,
 ⇒ PLEASE CHECK THE CONTINUITY OF THE INDOOR ↔ OUTDOOR CONNECTING CORD (F CABLE).

[OUTDOOR FAN MOTOR CHECK] DIAGNOSIS METHOD

- PUT THE POWER OFF.
 - REMOVE THE OUTDOOR FAN MOTOR'S CONNECTOR FROM CN24.
 - ROTATE THE FAN MOTOR BY HAND AND CHECK WHETHER THE FAN MOTOR IS LOCKED OR NOT.
 - MEASURE THE RESISTANCE BETWEEN EACH TERMINAL OF THE FAN MOTOR CONNECTOR. NORMAL RESISTANCE BETWEEN EACH TERMINAL: 20~50Ω
- * INSERT THE FAN MOTOR'S CONNECTOR AFTER FINISHING STEPS 1 TO 4.

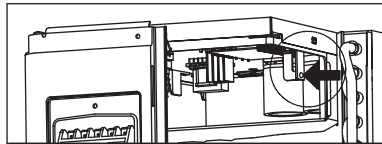

RIGHT SIDE ARROW INDICATE THE POSITION OF TEST SWITCH LEVER ON THE SIDE PANEL (SHOWN IN LEFT FIGURE.)



DURING STOP	
LD301 LIGHT	CONTENTS
	NORMAL OPERATION
2 SEC LIGHTING AND 0.3 SEC LIGHTS OUT REPETITION	OVERLOAD OPERATION (NORMAL OPERATION)

IN CASE OF DIFFICULT TO JUDGE THE ABNORMAL WITH ODU CONTROLLER OR THE COMP., BLINKING IN 2, 3, 4 OR 5 TIMES AT SELF-DIAGNOSIS IN THE STOPPING STATUS, PLEASE PERFORM THE MEGA CHECK AND CONFIRM THE INSULATION WITH THE COMPRESSOR. AS THERE IS NOT ABNORMAL FOR THE INSULATION WITH COMPRESSOR, PLEASE PERFORM [SELF-CHECK].

[SELF-CHECK] DIAGNOSIS METHOD	
1.	PUT THE POWER OFF.
2.	CUTTING [JW001] BY NIPPER OR BEING SHORT CIRCUIT BETWEEN [JW001] AND [JW002] (FASTEN TOGETHER WITH A CLIP).
3.	PUT THE POWER ON AND OPERATE INDOOR UNIT WITH VENTILATION MODE.
4.	PRESS TEST/SERVICE SWITCH FOR 1 SECOND OR MORE (WITHIN 3 MINUTES).
5.	SELF-CHECK RESULT WILL DISPLAY AT LD301, SEE THE ABOVE TABLE ([SELF-CHECK] DIAGNOSIS RESULT) FOR THE DETAIL.
6.	PUT THE POWER OFF, THEN RELEASE BACK JW001 AND JW002 TO ORIGINAL CONDITION (NO SHORT CIRCUIT CONDITION).

* IF FORGET TO RELEASE BACK JW001 AND JW002, THE TIMER LAMP OF THE INDOOR UNIT BLINKS 12 TIMES.

[SELF-CHECK] DIAGNOSIS RESULT		
SELF-DIAGNOSIS BLINKING MODE <input checked="" type="checkbox"/> :BLINK <input type="checkbox"/> :OFF		
LD301 (RED)	SELF-DIAGNOSIS CONTENTS	HOW TO REPAIR
<input checked="" type="checkbox"/>	NOT CONTROLLER DEFECTIVE	• CHANGE THE COMPRESSOR
<input checked="" type="checkbox"/>	FOUND PEAK CURRENT ERROR	• CHANGE ODU CONTROLLER
<input checked="" type="checkbox"/>	COMPRESSOR CURRENT ABNORMAL	• CHECK THE COMPRESSOR CONNECTOR AND CONNECT IT PROPERLY. • IF ABOVE ARE OK, CHANGE THE ODU CONTROLLER
<input checked="" type="checkbox"/>	ABNORMAL DC VOLTAGE	• REACTOR IS DISCONNECTION, → CONNECT IT PROPERLY • IF AC VOLTAGE INPUT ABNORMAL (OVER STANDARD VOLTAGE ±10%) → FOLLOW STANDARD AC VOLTAGE INPUT • IF AC VOLTAGE INPUT IS NORMAL (WITHIN ±10%) → CHANGE P.W.B
<input checked="" type="checkbox"/>	EEPROM READING ERROR	• CHANGE ODU CONTROLLER

DURING STOP			
SELF-DIAGNOSIS BLINKING MODE <input checked="" type="checkbox"/> :BLINK <input type="checkbox"/> :OFF			
LD301 (RED)	SELF DIAGNOSIS CONTENTS	MAIN CHECK POINT	HOW TO REPAIR
<input type="checkbox"/>	NORMAL STOP (STOPPED BY INDOOR THERMOSTAT OR MAIN OPERATION OFF)	1. NO NEED TO CHECK	1. NOT ANY MALFUNCTION
<input checked="" type="checkbox"/>	FAN MODE OPERATION, RESET STOP	1. INDOOR AIR CLEAN OPERATION	1. NOT ANY MALFUNCTION
<input checked="" type="checkbox"/>	PEAK CURRENT CUT	2. OTHER CAUSE	2. CHANGE ODU CONTROLLER
2 TIMES	ABNORMAL LOW SPEED ROTATION	1. ODU CONTROLLER DEFECTIVE 2. COMPRESSOR ABNORMAL LOAD	1. CHANGE ODU CONTROLLER 2. CHECK THE COMPRESSOR
3 TIMES	SWITCHING FAILURE	1. COMPRESSOR CONNECTOR OPEN 2. COMPRESSOR ABNORMAL LOAD 3. ODU CONTROLLER DEFECTIVE	1. INSERT THE CONNECTOR 2. CHECK THE COMPRESSOR 3. CHANGE ODU CONTROLLER
4 TIMES	OVERLOAD LOWER LIMIT CUT	1. OBSTACLE SURROUND THE ODU MAY CAUSE 2. OTHER CAUSE	1. REMOVE THE OBSTRUCTION 2. CHECK CYCLE PIPE
5 TIMES	OH THERMISTOR TEMPERATURE RISE	1. DUE TO OPEN CONNECTOR 2. LEAKAGE OF REFRIGERANT 3. OTHER CAUSE	1. INSERT THE CONNECTOR 2. CHECK THE CYCLE PIPE AND RECHARGE THE REFRIGERANT 3. CHANGE ODU CONTROLLER
6 TIMES	THERMISTOR ABNORMAL	1. CONNECTOR INSERT MISS 2. OPEN CIRCUIT/SHORT CIRCUIT OF THERMISTOR WIRE 3. ODU CONTROLLER DEFECTIVE	1. INSERT PROPERLY 2. CHANGE THE THERMISTOR 3. CHANGE ODU CONTROLLER
7 TIMES	COMMUNICATIONS ERROR	1. F CABLE MISS CONNECTION 2. F CABLE DISCONNECTION 3. ODU CONTROLLER DEFECTIVE	1. F CABLE CONNECT PROPERLY 2. CHANGE THE F CABLE 3. CHANGE ODU CONTROLLER
9 TIMES	ABNORMAL POWER SOURCE	1. REACTOR IS UNCONNECTED 2. ABNORMAL AC INPUT: OUT OF THE RANGE (230±10%) 3. AC INPUT IS NORMAL	1. CONNECT REACTOR PROPERLY 2. CONNECT TO NORMAL AC POWER SOURCE 3. CHANGE ODU CONTROLLER
10 TIMES	ODU FAN STOP BY STRONG REVERSE WIND	1. OUTDOOR FAN STOP BY STRONG REVERSE WIND	1. IT WILL RE-START AFTER THE WIND BECOME WEAK
11 TIMES	ODU FAN LOCK ERROR	1. OUTDOOR FAN STOP BY STRONG REVERSE WIND 2. PROPELLER FAN LOCK 3. OUTDOOR FAN MOTOR LOCK 4. OUTDOOR FAN MOTOR OK	1. AUTOMATICALLY RE-START AFTER WIND BECOME WEAK 2. REMOVE THE OBSTRUCTION 3. CHANGE THE FAN MOTOR 4. CHANGE ODU CONTROLLER
12 TIMES	EEPROM READ ERROR	• CHANGE OUTDOOR UNIT CONTROLLER	
13 TIMES	ACTIVE VOLTAGE ABNORMAL	1. ABNORMAL OUTDOOR CONTROLLER 2. ABNORMAL COMPRESSOR LOAD	1. CHANGE ODU CONTROLLER 2. CHECK THE COMPRESSOR
14 TIMES	CIRCUIT ABNORMAL	• CHANGE OUTDOOR UNIT CONTROLLER	
15 TIMES	HIGH LOAD STOP	1. SERVICE VALVE CLOSE 2. OBSTACLE SURROUND THE ODU UNIT MAY CAUSE 3. CLOGGED FILTER IN INDOOR UNIT CAUSE.	1. CHECK SERVICE VALVE 2. REMOVE THE OBSTRUCTION 3. CHECK FILTER
16 TIMES			

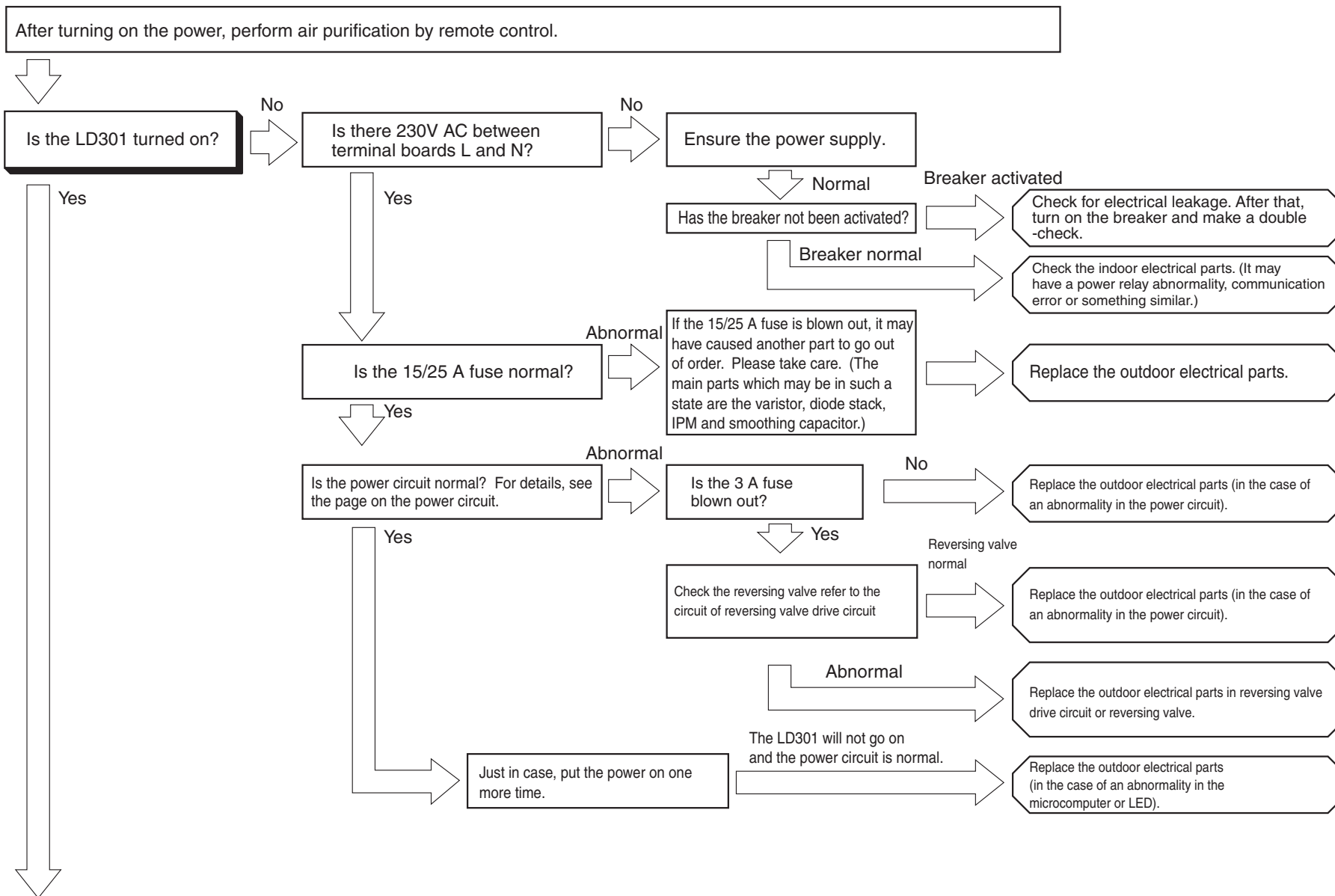

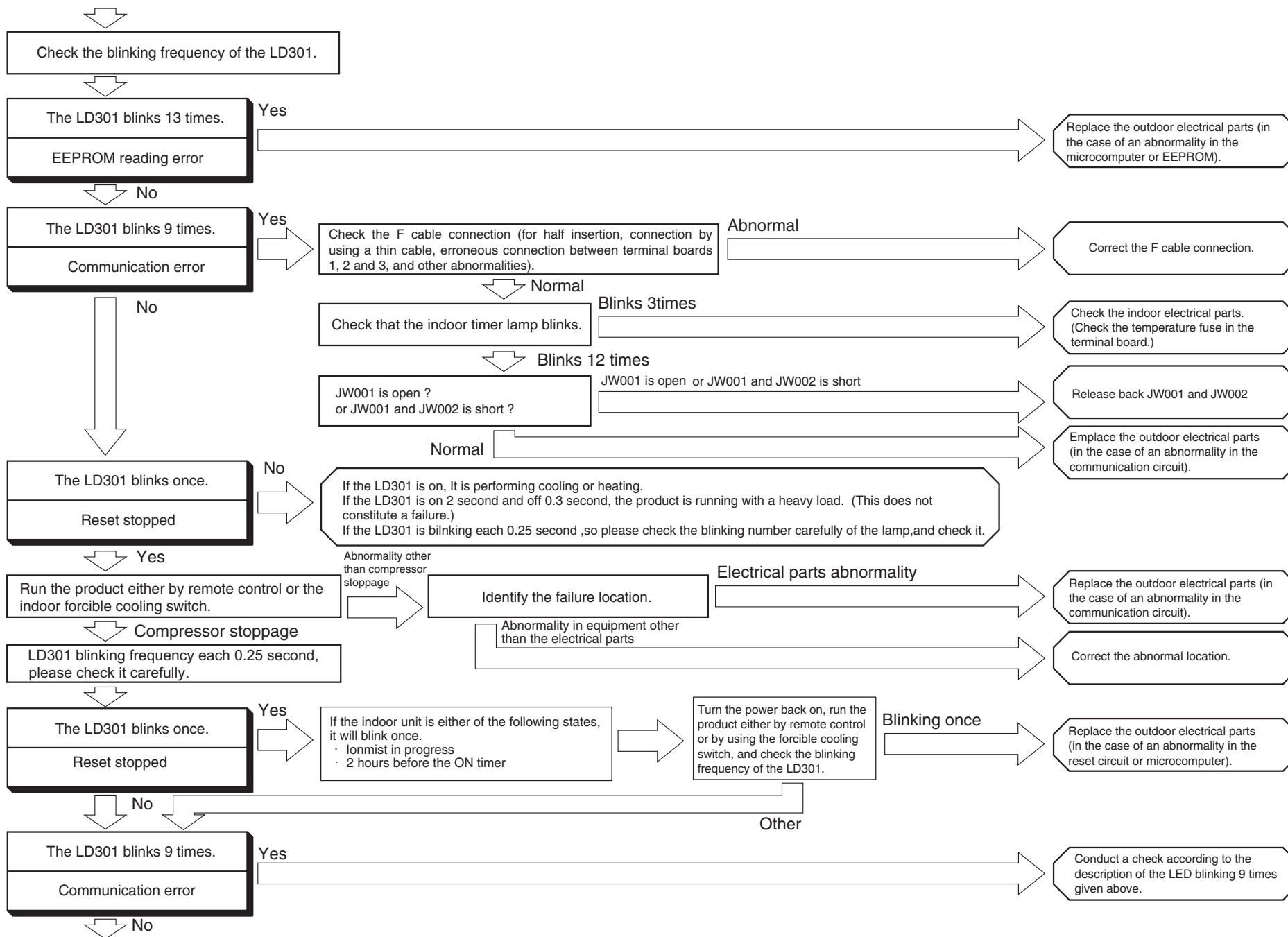

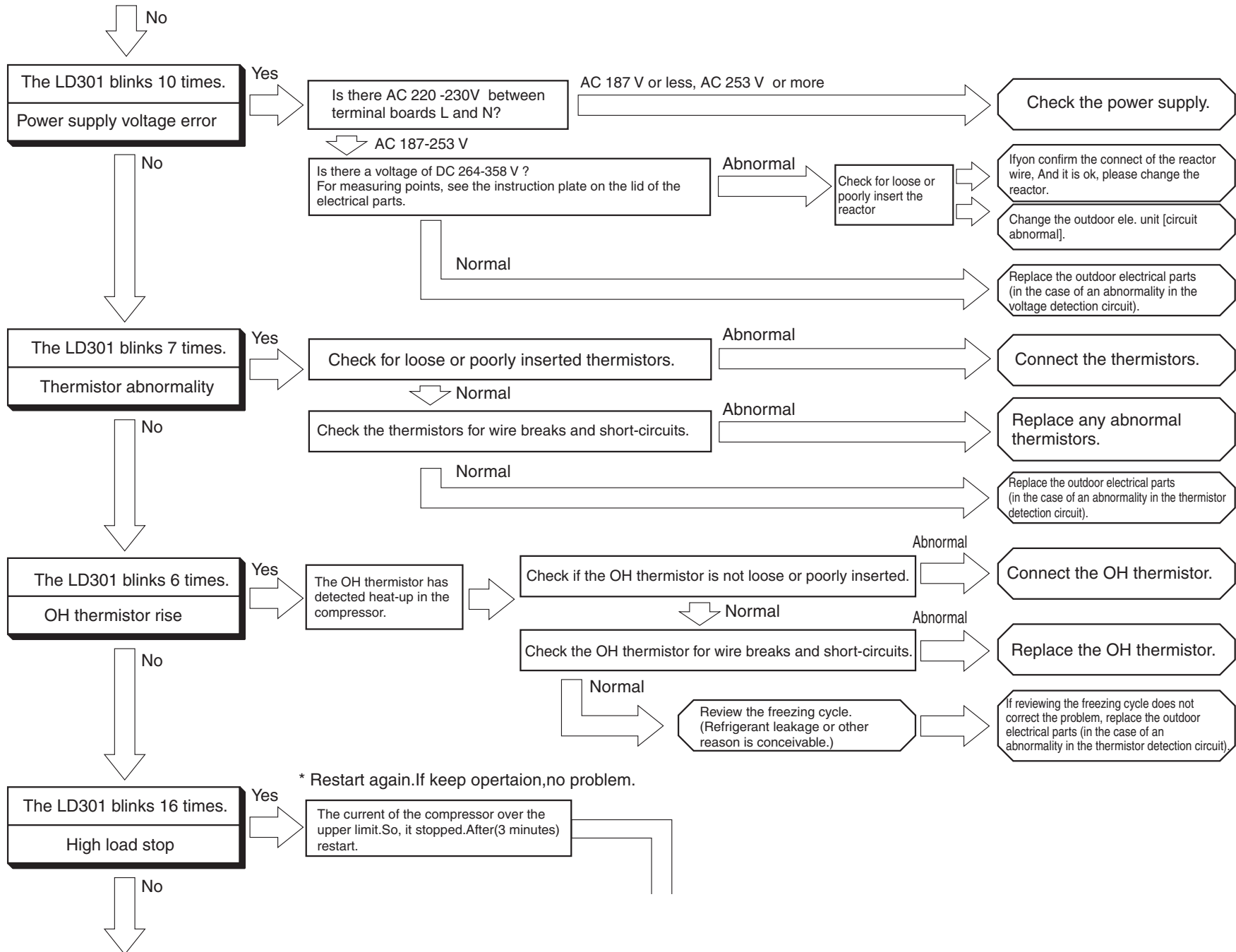

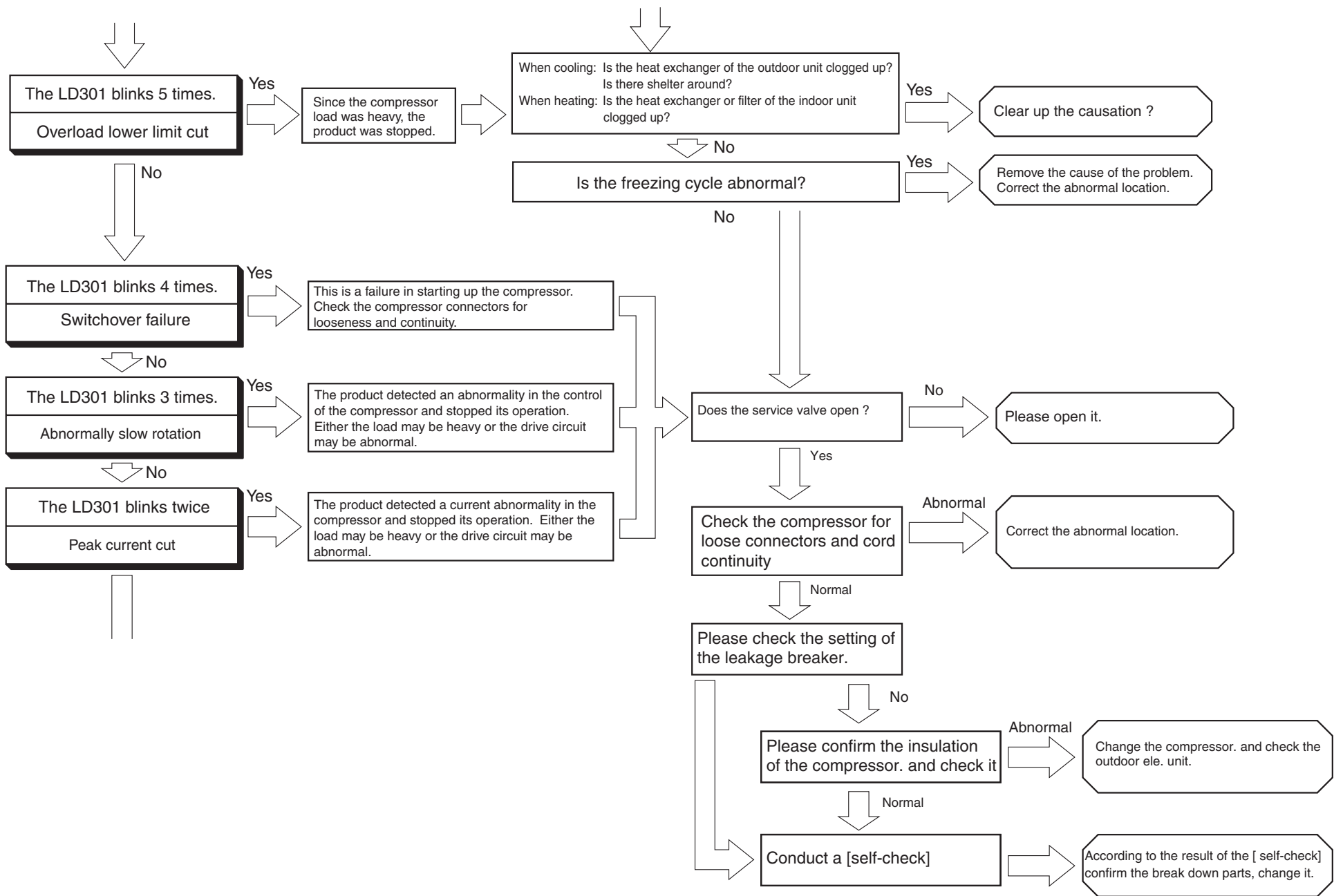

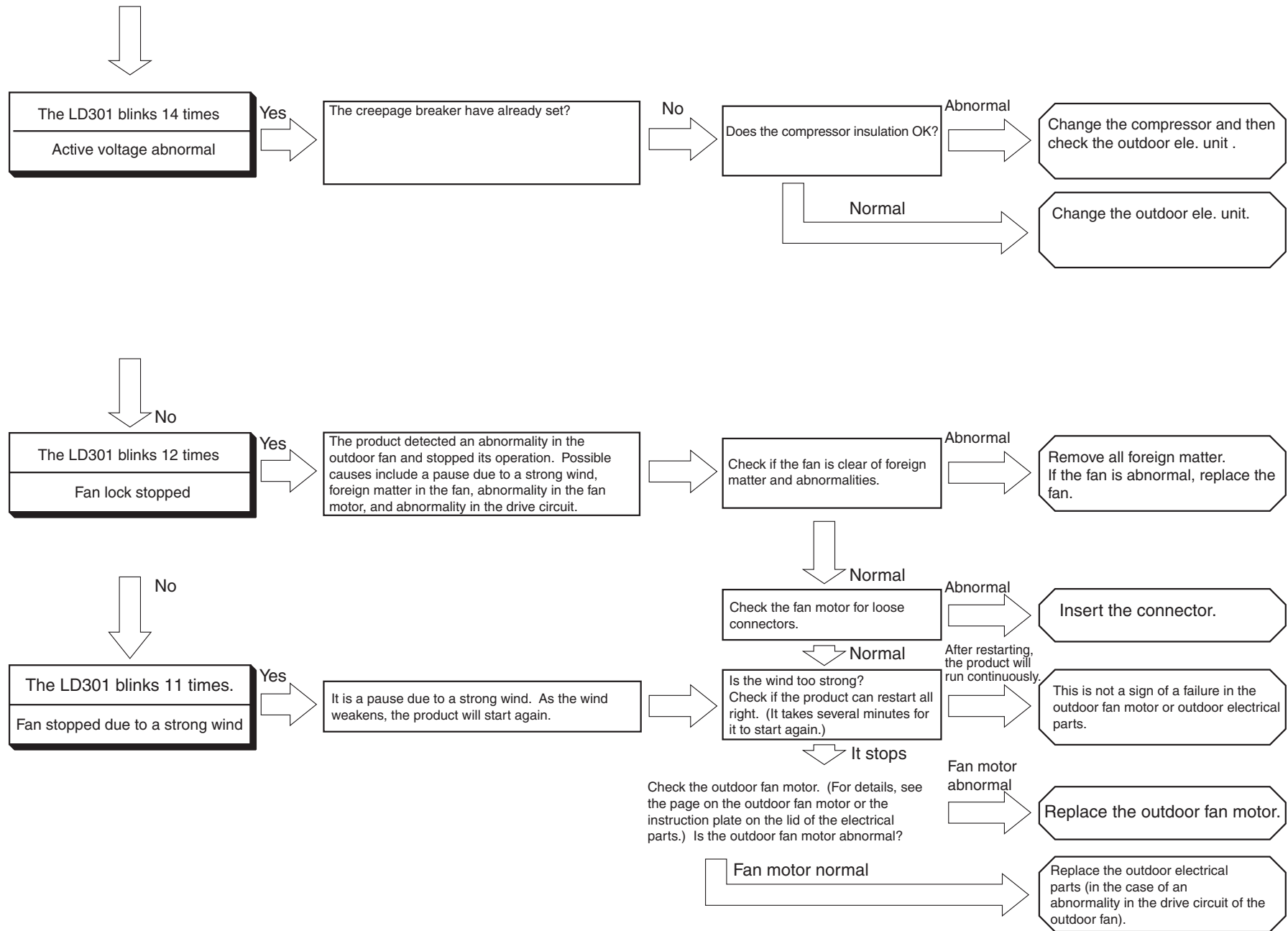

CHECKING THE REFRIGERATING CYCLE

(JUDGING BETWEEN GAS LEAKAGE AND COMPRESSOR DEFECTIVE)

1. Troubleshooting procedure (No operation, No heating, No cooling)

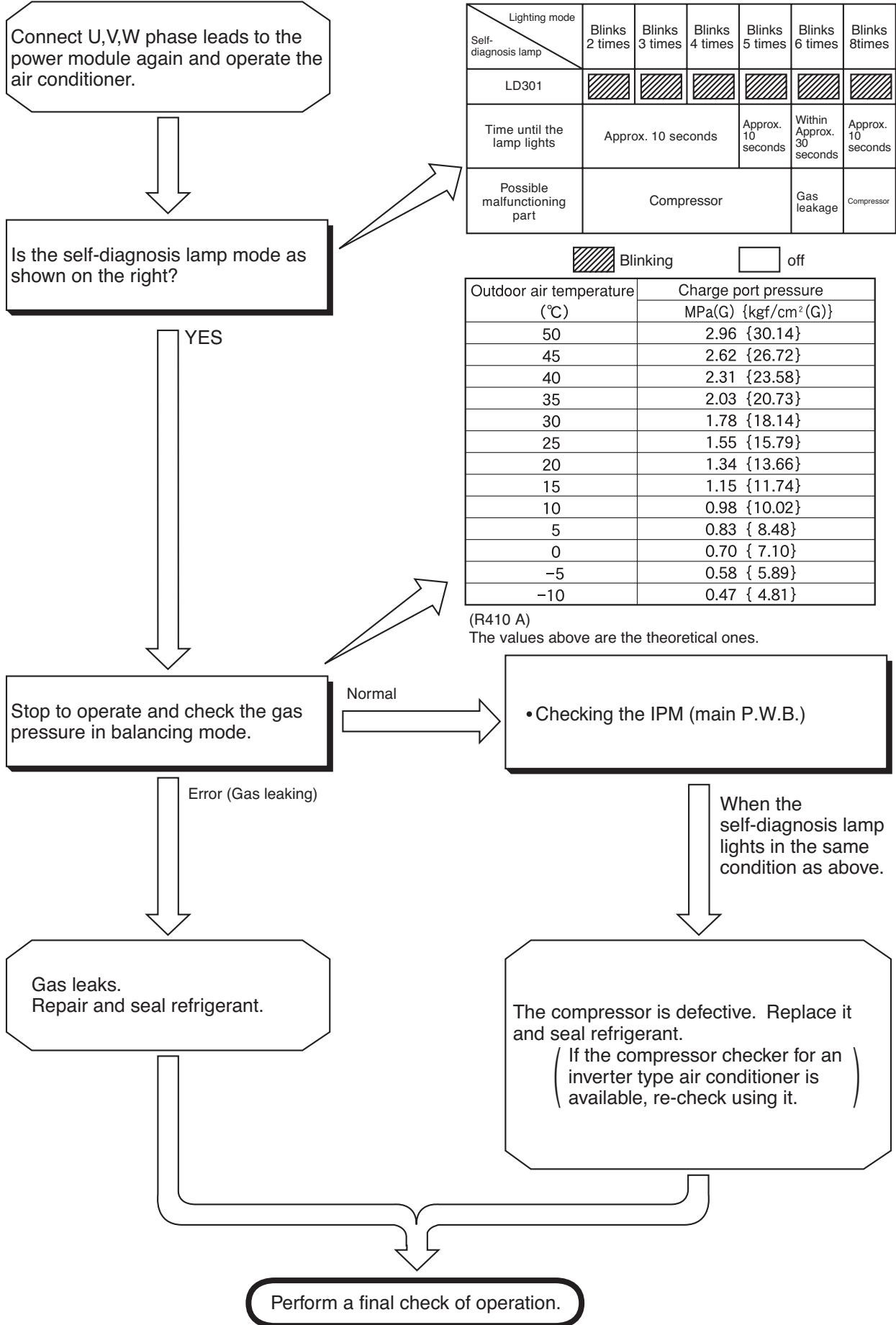

How to run the product with the outdoor unit test switch

If the indoor electrical parts is out of order and if you wish to run the outdoor unit

1. Turn on the outdoor terminal boards L and N (220-230 V AC).
2. Confirm that the "LD301" blinks once from the terminal side of the outdoor unit. Afterwards (when about 30 sec elapses after the power turns on), confirm that the "LD301" changes to blinking 9 times (communication error).
3. When the "LD301" is blinks 9 times, if you press the test switch, the "LD301" lights up.

If you release your finger from the test switch within 1 sec to 5 sec after pressing the switch, the forced cooling operation starts.

※(If you press the test switch for 5 sec or longer, the self-check diagnosis starts. In this case, turn the power off and start the procedure from 1 again.)

※(For the initialization of the expansion valve, it may take 1 min until the operation starts.)

4. When you press the test switch again for 1 sec or longer, the unit stops the operation.

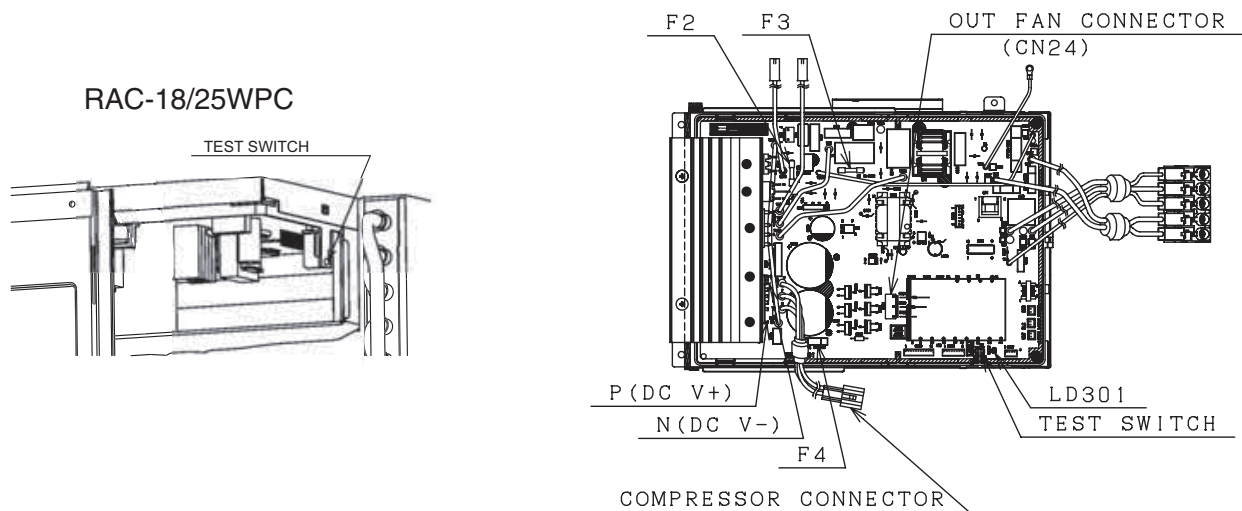

※Cautions

1. Applying power directly to the outdoor unit will cause a rush current to stress the outdoor unit. Therefore, if the indoor unit is not out of order, do not use the method described in 2).
2. Before making the connections, be sure to turn off the breaker.
3. Do not under any circumstances run the product for more than 5 minutes.
4. Doing work with the compressor connector removed will cause the LD301 to blink 4 times. It will not start.
5. For another test run, turn off the breaker and turn it back on. (The test switch is accepted only once after power-on. After operation by remote control, it is not accepted.)
6. When the operation with the test switch is over, turn off the breaker and set the connectors back.

HOW TO OPERATE THE OUTDOOR UNIT INDEPENDENTLY

RAC-18/25WPC

1. Connect the large dia. pipe side and small dia. pipe side service valve using a pipe.

Connect the small diameter service valve and the large diameter service valve using the reducing union and copper pipe as shown on the right.

Charge refrigerant of 300g after vacuuming (※1)

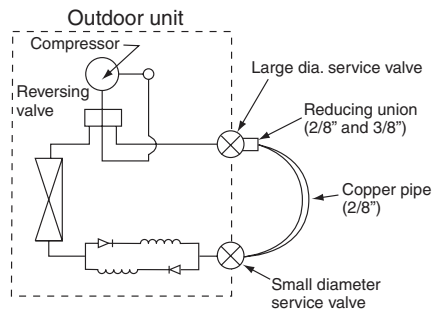

Parts to be prepared

- (1) Reducing union
2/8" (6.35 mm)
3/8" (9.52 mm)
- (2) Copper pipe (2/8" and 3/8")

Do not operate for more than 5 minutes

The operation method is the same as "How to operate using the connector to servicing the outdoor unit".

※1 The charging amount of 300g is equivalent to the load in normal operation.

OUTDOOR UNIT

MODEL RAC-18/25WPC

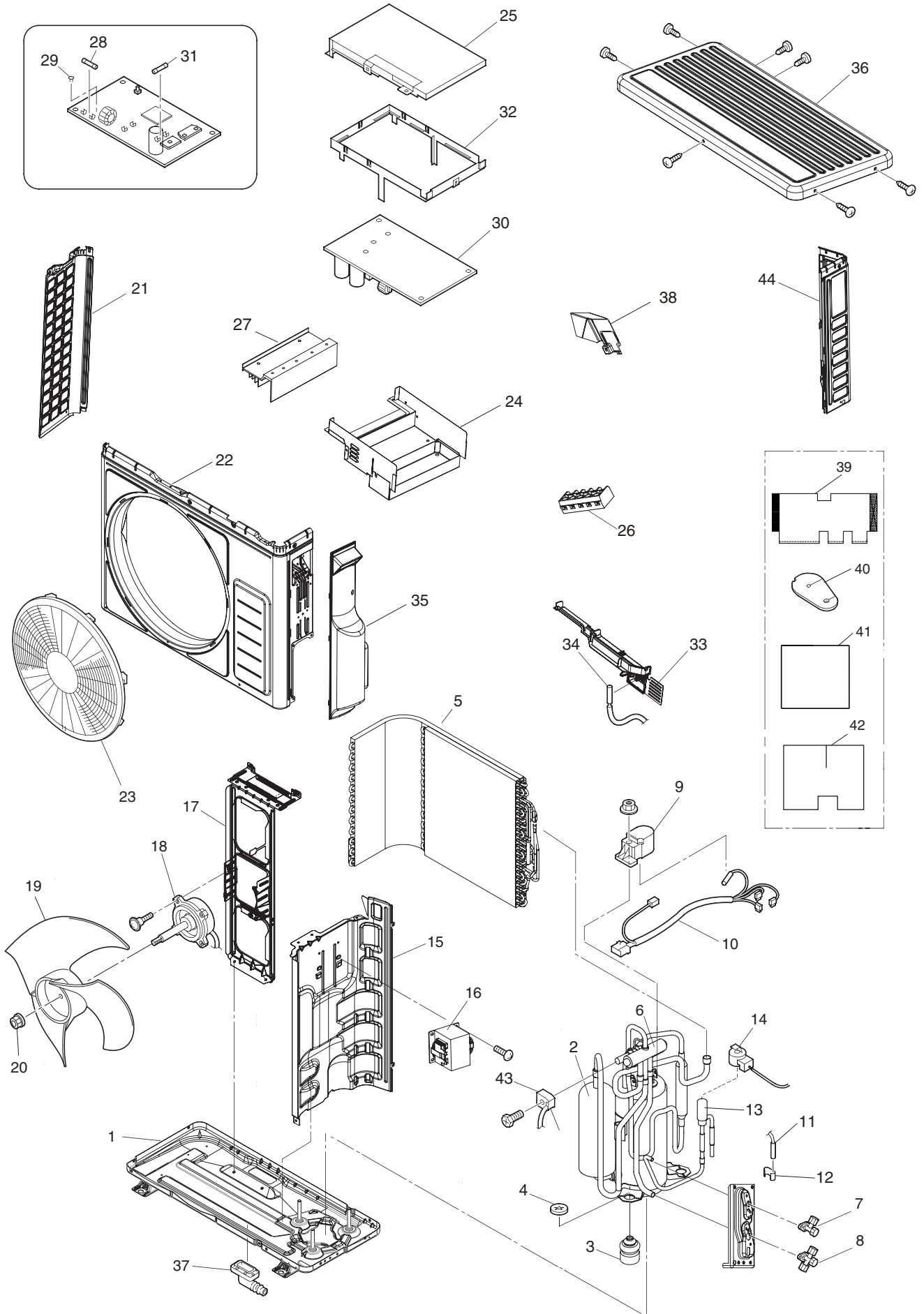

OUTDOOR UNIT

NO	HHAW PARTS NO	Q' TY/ UNIT	PARTS NAME
1	HWRAC-K10HCG A01	1	BASE
2	HWRAC-18WEB A02	1	COMPRESSOR
3	HWRAC-18WEB A03	3	COMPRESSOR RUBBER
4	HWRAC-18WEB A04	3	PUSH NUT
5	HWRAC-18WEB A05	1	CONDENSER
6	HWRAC-18WPC A01	1	REVERSING VALVE
7	HWRAC-50WEA A06	1	2S-VALVE
8	HWRAC-10GH5 A03	1	3S-VALVE
9	HWRAC-18WEB A07	1	O. L. R COVER
10	HWRAC-18WPC A02	1	CONNECTING CORD (COMP)
11	HWRAC-E10H2 A09	1	THERMISTOR (DEFROST)
12	HWRAC-D10EX A08	1	THERMISTOR SUPPORT
13	HWRAC-18WEB A08	1	ELECTRIC EXPAN. VALVE
14	HWRAC-E08H A09	1	COIL (EXPAN. VALVE)
15	HWRAC-18WEB A33	1	PARTITION (WITH BUTYL SHEET)
16	HWRAC-35WPC A07	1	REACTOR 1
17	HWRAC-18WPC A03	1	FAN MOTOR SUPPORT
18	HWRAC-25YHA5 A15	1	FAN MOTOR
19	HWRAC-25YHA5 A16	1	PROPELLER FAN
20	HWRAC-25YH4 A24	1	NUT (PROPELLER. FAN)
21	HWRAC-K10HCG A10	1	SIDE COVER (L)
22	HWRAC-18WEB A15	1	FRONT COVER
23	HWRAC-18WEB A16	1	DISCHARGE GRILL
24	HWRAC-18WPC A04	1	ELECTRIC PARTS PLATE
25	HWRAC-18WEB A18	1	ELECTRIC PARTS COVER
26	HWRAC-K10HCG A12	2	TERMINAL BOARD (5P)
27	HWRAC-18WEB A20	1	HEAT SINK (REGURATOR 1)
28	HWRAC-K10HCG A21	1	FUSE (15A)
29	HWRAC-50NX2 A52	2	FUSE (3. 15A)
30	HWRAC-18WPC A05	1	P. W. B. (MAIN)
	HWRAC-25WPC A01	1	P. W. B. (MAIN)
31	HWRAC-18WEB A22	1	FUSE (15A)
32	HWRAC-18WEB A23	1	SUPPORT (P. W. B.)
33	HWRAC-K10HCG A14	1	COVER (OUT DOOR THERMISTOR)
34	HWRAC-D10EX A17	1	THERMISTOR (OUT DOOR TEMP.)
35	HWRAC-K10HCG A15	1	EV-COV-ZU
36	HWRAC-18WEB A26	1	T-COVERZU
37	HWRAC-25YHA4 A50	1	DRAIN PIPE
38	HWRAC-18WEB A28	1	TERM-COVER
39	HWRAC-18WPC A06	1	SOUND PROOF COVER ASS' Y
40	HWRAC-K10HCG A18	1	SOUND PROOF COVER ASS' Y
41	HWRAC-18WEB A30	1	SOUND PROOF COVER ASS' Y
42	HWRAC-K14HCG A03	1	SOUND PROOF COVER ASS' Y
43	HWRAC-18WPC A07	1	COIL (REVERSING VALVE)
44	HWRAC-18WEB A32	1	SIDE COVER (R)

HITACHI

RAC-18WPC
RAC-25WPC

HHAW NO. 01000E