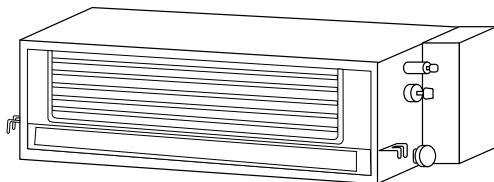
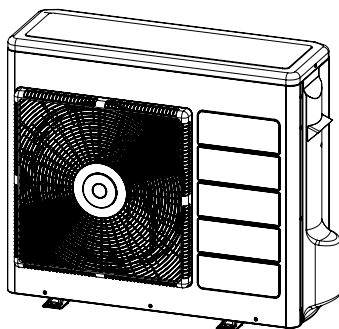
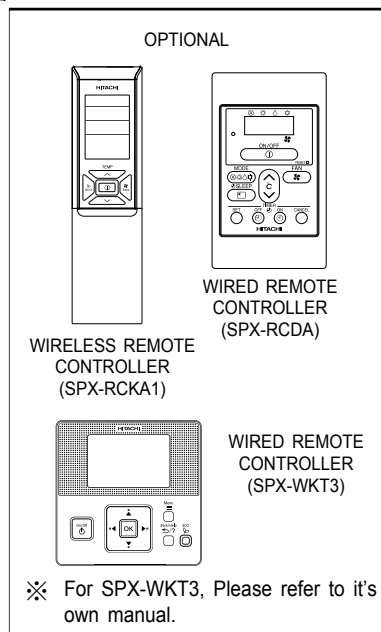

SERVICE MANUAL TECHNICAL INFORMATION

FOR SERVICE PERSONNEL ONLY
REFER TO THE FOUNDATION MANUAL

**RAD-50PPD
RAD-60PPD**

**RAC-50NPD
RAC-60NPD**

CONTENTS

SPECIFICATIONS	5
HOW TO USE	8
CONSTRUCTION AND DIMENSIONAL DIAGRAM	52
MAIN PARTS COMPONENT	55
WIRING DIAGRAM	57
CIRCUIT DIAGRAM	62
BLOCK DIAGRAM	71
BASIC MODE	73
REFRIGERATING CYCLE DIAGRAM.....	83
DESCRIPTION OF MAIN CIRCUIT OPERATION	84
SERVICE CALL Q & A	103
TROUBLE SHOOTING	106
PARTS LIST AND DIAGRAM	141

SPECIFICATIONS

TYPE		(DUCT TYPE)			
		INDOOR UNIT	OUTDOOR UNIT	INDOOR UNIT	OUTDOOR UNIT
MODEL		RAD-50PPD	RAC-50NPD	RAD-60PPD	RAC-60NPD
POWER SOURCE		1 Ø, 50/60 Hz, 220-240V		1 Ø, 50/60 Hz, 220-240V	
COOLING	TOTAL INPUT (W)	1,420 (300 ~ 2,500)		1,710 (300 ~ 2,600)	
	TOTAL AMPERES (A)	6.52 - 5.98		7.85 - 7.20	
	CAPACITY (kW)	5.00 (1.20 ~ 5.80)		6.00 (1.20 ~ 6.50)	
	(B.T.U./h)	17,060 (4,090 ~ 19,780)		20,470 (4,090 ~ 22,170)	
HEATING	TOTAL INPUT (W)	1,570 (300 ~ 2,650)		1,840 (300 ~ 2,650)	
	TOTAL AMPERES (A)	7.21 - 6.61		8.45 - 7.74	
	CAPACITY (kW)	6.00 (1.20 ~ 6.80)		7.00 (1.20 ~ 8.00)	
	(B.T.U./h)	20,470 (4,090 ~ 23,200)		23,880 (4,090 ~ 27,290)	
DIMENSIONS (mm)	W	900	850	900	850
	H	270	750	270	750
	D	720	298	720	298
NET WEIGHT (kg)		35	50	35	50

※ After installation

SPECIFICATIONS AND PARTS ARE SUBJECT TO CHANGE FOR IMPROVEMENT

ROOM AIR CONDITIONER

INDOOR UNIT + OUTDOOR UNIT

SAFETY DURING REPAIR WORK

1. In order to disassemble and repair the unit in question, be sure to disconnect the power cord plug from the power outlet before starting the work.

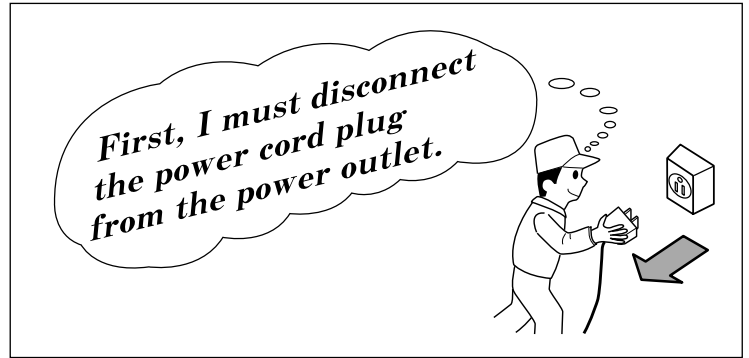

2. If it is necessary to replace any parts, they should be replaced with respective genuine parts for the unit, and the replacement must be effected in correct manner according to the instructions in the Service Manual of the unit.

If the contacts of electrical parts are defective, replace the electrical parts without trying to repair them.



3. After completion of repairs, the initial state should be restored.
4. Lead wires should be connected and laid as in the initial state.
5. Modification of the unit by the user himself should absolutely be prohibited.
6. Tools and measuring instruments for use in repairs or inspection should be accurately calibrated in advance.
7. In installing the unit having been repaired, be careful to prevent the occurrence of any accident such as electrical shock, leak of current, or bodily injury due to the drop of any part.
8. To check the insulation of the unit, measure the insulation resistance between the power cord plug and grounding terminal of the unit. The insulation resistance should be $1M\Omega$ or more as measured by a 500V DC megger.
9. The initial location of installation such as window, floor or the other should be checked for being and safe enough to support the repaired unit again. If it is found not so strong and safe, the unit should be installed at the initial location after reinforced or at a new location.

10. Any inflammable object must not be placed about the location of installation.
11. Check the grounding to see whether it is proper or not, and if it is found improper, connect the grounding terminal to the earth.

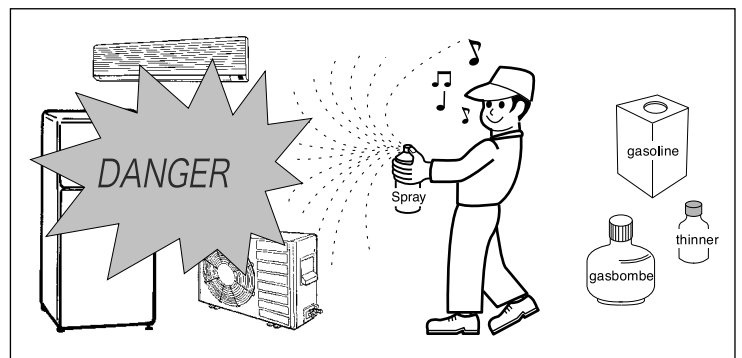

WORKING STANDARDS FOR PREVENTING BREAKAGE OF SEMICONDUCTORS

1. Scope

The standards provide for items to be generally observed in carrying and handling semiconductors in relative manufacturers during maintenance and handling thereof. (They apply the same to handling of abnormal goods such as rejected goods being returned).

2. Object parts

- (1) Micro computer
- (2) Integrated circuits (I.C.)
- (3) Field-effective transistor (F.E.T.)
- (4) P.C. boards or the like to which the parts mentioned in (1) and (2) of this paragraph are equipped.

3. Items to be observed in handling

- (1) Use a conductive container for carrying and storing of parts. (Even rejected goods should be handled in the same way).

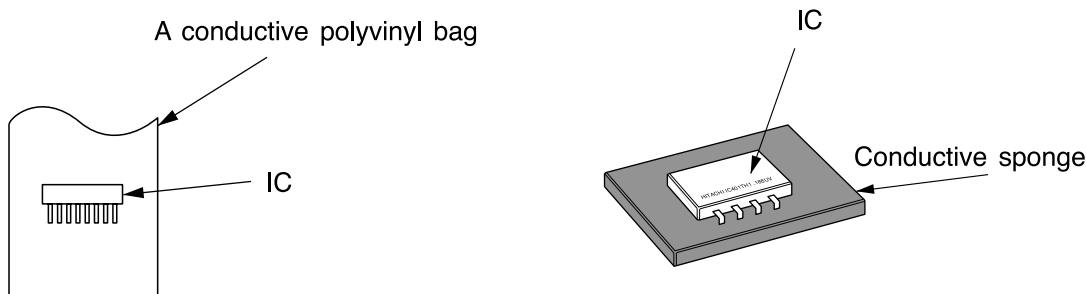

Fig. 1. Conductive container

- (2) When any part is handled uncovered (in counting, packing and the like), the handling person must always use himself as a body earth. (Make yourself a body earth by passing $1M\Omega$ earth resistance through a ring or bracelet).
- (3) Be careful not to touch the parts with your clothing when you hold a part even if a body earth is being taken.
- (4) Be sure to place a part on a metal plate with grounding.
- (5) Be careful not to fail to turn off power when you repair the printed circuit board. At the same time, try to repair the printed circuit board on a grounded metal plate.

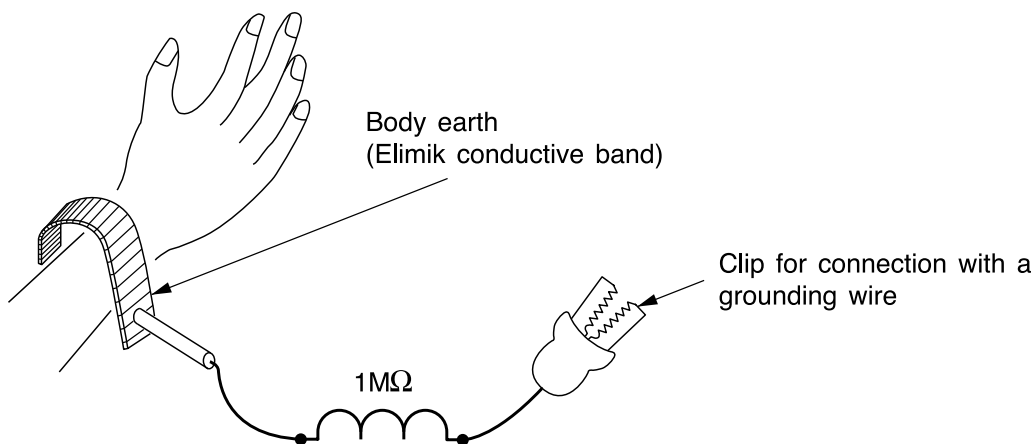

Fig. 2. Body Earth

(6) Use a three wire type soldering iron including a grounding wire.

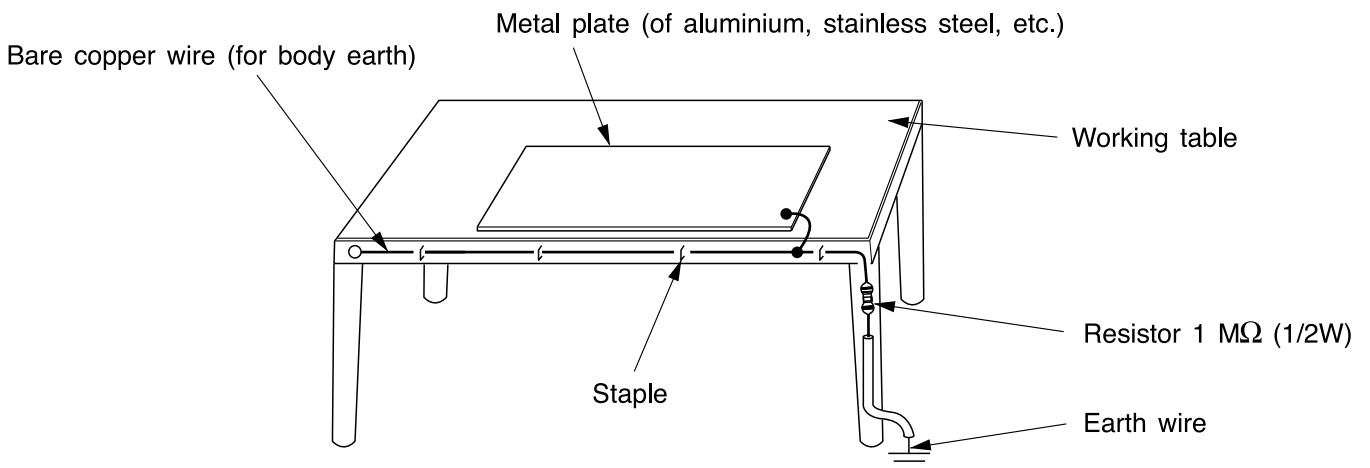

Fig. 3. Grounding of the working table

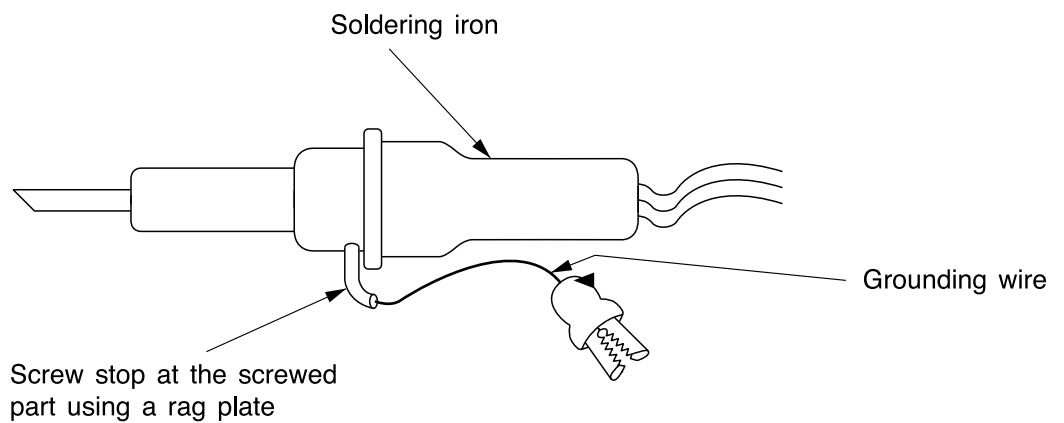

Fig. 4. Grounding a solder iron

Use a high insulation mode (100V, 10MΩ or higher) when ordinary iron is to be used.

(7) In checking circuits for maintenance, inspection or some others, be careful not to have the test probes of the measuring instrument short circuit a load circuit or the like.

 **CAUTION**

1. In quiet or stop operation, slight flowing noise of refrigerant in the refrigerating cycle is heard occasionally, but this noise is not abnormal for the operation.
2. When it thunders nearby, it is recommended to stop the operation and to disconnect the power cord plug from the power outlet for safety.
3. In the event of power failure, the airconditioner will restart automatically in the previously selected mode once the power is restored. In the event of power failure during TIMER operation, the airconditioner will not start automatically. Re-press START/STOP button after 3 minutes from when unit stopped or power recovery.
4. If the room air conditioner is stopped by adjusting thermostat, or miss operation, and re-start in a moment, there is occasion that the cooling and heating operation does not start for 3 minutes, it is not abnormal and this is the result of the operation of IC delay circuit. This IC delay circuit ensures that there is no danger of blowing fuse or damaging parts even if operation is restarted accidentally.
5. This room air conditioner should not be used at the cooling operation when the outside temperature is below -15°C (5°F).
6. This room air conditioner (the reverse cycle) should not be used when the outside temperature is below -15°C (5°F).
If the reverse cycle is used under this condition, the outside heat exchanger is frosted and efficiency falls.

SPECIFICATIONS

MODEL		RAD-50PPD RAD-60PPD	RAC-50NPD RAC-60NPD
FAN MOTOR		180W	DC47W
FAN MOTOR CAPACITOR		NO	NO
FAN MOTOR PROTECTOR		NO	NO
COMPRESSOR		—	JX151XG1
COMPRESSOR MOTOR CAPACITOR		NO	NO
OVERLOAD PROTECTOR		NO	NO
OVERHEAT PROTECTOR		NO	YES
FUSE (MICRO COMPUTER CIRCUIT)		3.15A	3A
POWER RELAY		NO	G4A
POWER SWITCH		NO	NO
TEMPORARY SWITCH		YES	NO
TEST/SERVICE SWITCH		NO	YES
TRANSFORMER		NO	NO
VARISTOR		450NR	450NR
NOISE SUPPRESSOR		NO	YES
THERMOSTAT		YES(IC)	YES(IC)
REMOTE CONTROL SWITCH (LIQUID CRYSTAL)		YES	NO
REFRIGERANT CHARGING VOLUME (Refrigerant R32)	UNIT	-----	1500g
	PIPES (MAX. 30M) (MIN. 3M)	CHARGELESS	

Figure showing the installation of Indoor unit

⚠ CAUTION

- Install the indoor unit with a proper clearance around it for operation and maintenance working space.
- In case that the ceiling board can not be detected for servicing, prepare a service access door below the indoor unit for removing the indoor unit.

The indoor piping should be insulated with the enclosed insulation pipe. (If the insulator is insufficient, please use commercial products.)

Be sure to completely seal any gap with putty.

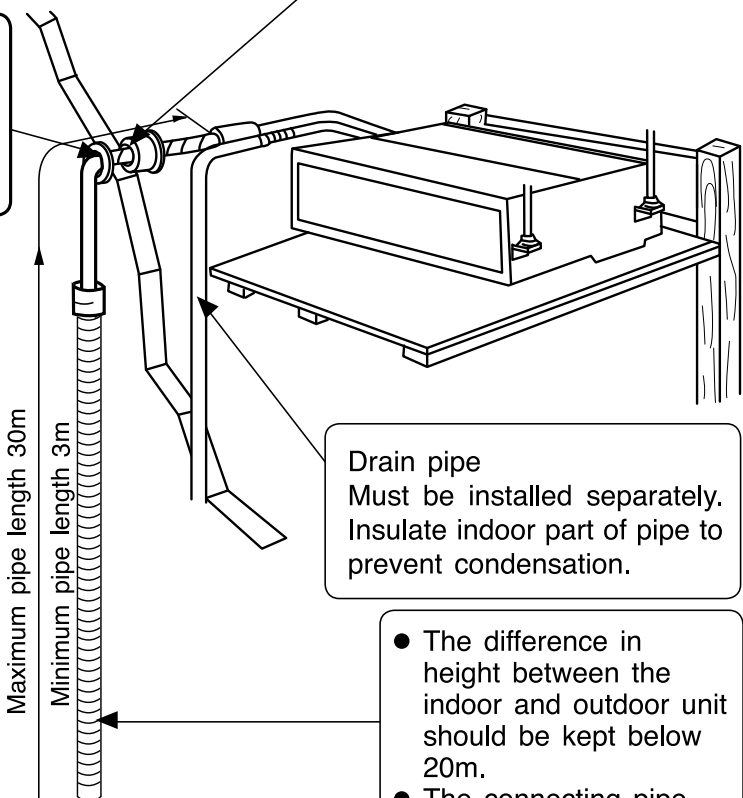

Drain pipe
Must be installed separately.
Insulate indoor part of pipe to prevent condensation.

Refrigerant piping must be protected from physical damage. Install a plastic cover or equivalent.

⚠ CAUTION

- Install the indoor unit with a proper clearance around it for operation and maintenance working space.
- In case that the ceiling board can not be detected for servicing, prepare a service access door below the indoor unit for removing the indoor unit.

⚠ CAUTION

- Discharge grille and suction grille shall be covered by insulation material to prevent water drop.

⚠ CAUTION

Always install the indoor unit level. Units not installed level may leak.

- The difference in height between the indoor and outdoor unit should be kept below 20m.
- The connecting pipe, no matter big or small, should all be insulated with insulation pipe and then wrapped with vinyl tape. (The insulator will deteriorate if it is not wrapped with tape).

Figure showing the installation of Outdoor unit

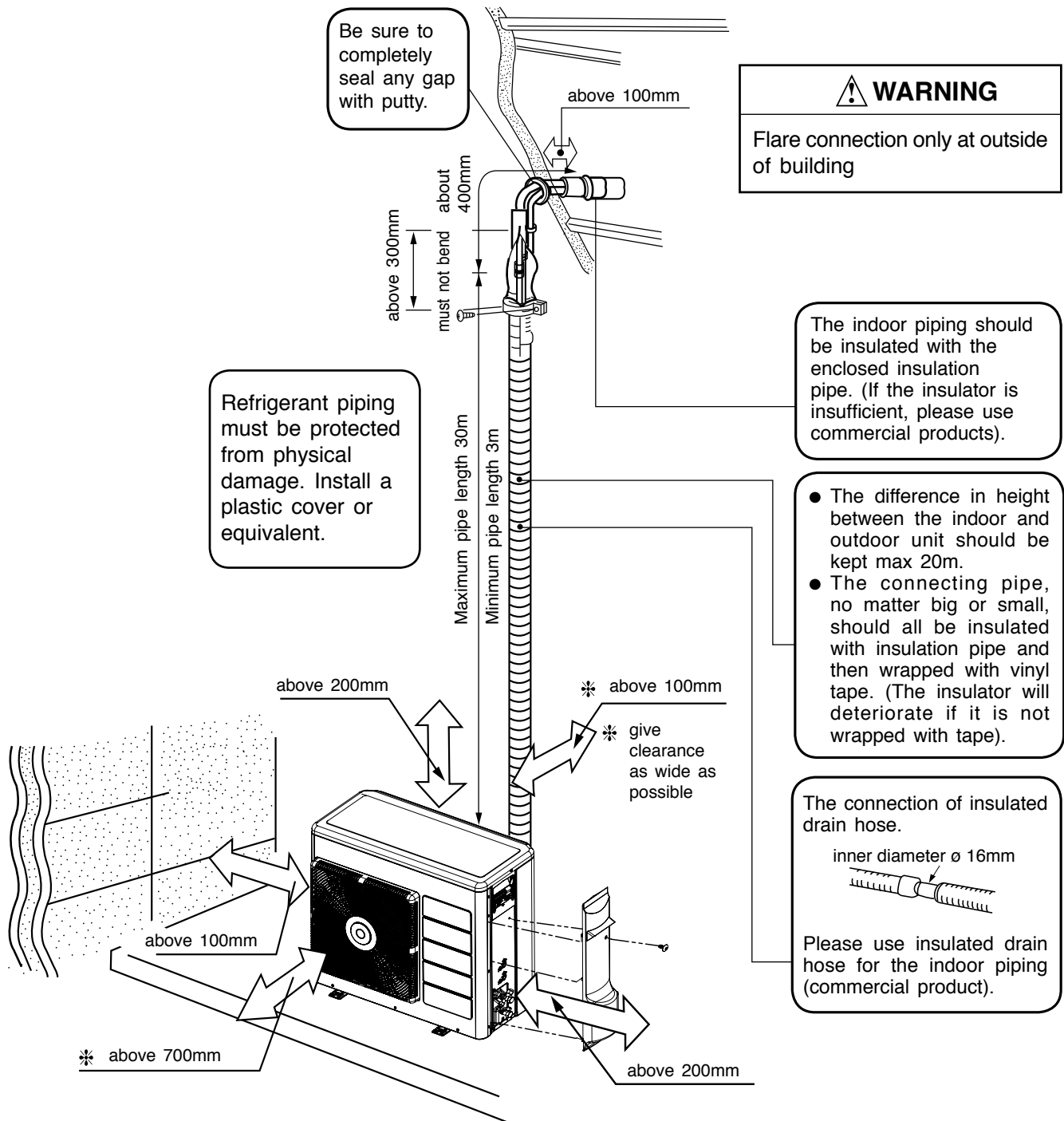

Be sure to completely seal any gap with putty.

WARNING
Flare connection only at outside of building

Refrigerant piping must be protected from physical damage. Install a plastic cover or equivalent.

The indoor piping should be insulated with the enclosed insulation pipe. (If the insulator is insufficient, please use commercial products).



- The difference in height between the indoor and outdoor unit should be kept max 20m.
- The connecting pipe, no matter big or small, should all be insulated with insulation pipe and then wrapped with vinyl tape. (The insulator will deteriorate if it is not wrapped with tape).





The connection of insulated drain hose.
inner diameter ø 16mm
Please use insulated drain hose for the indoor piping (commercial product).



SAFETY PRECAUTION





- Please read the “Safety Precaution” carefully before operating the unit to ensure correct usage of the unit.
- Pay special attention to signs of “ **▲ Warning**” and “ **▲ Caution**”. The “Warning” section contains matters which, if not observed strictly, may cause death or serious injury. The “Caution” section contains matters which may result in serious consequences if not observed properly. Please observe all instructions strictly to ensure safety.
- The sign indicate the following meanings.

 Make sure to connect earth line.	 The sign in the figure indicates prohibition.
 Indicates the instructions that must be followed.	



 WARNING	This symbol shows that this equipment uses a flammable refrigerant. If the refrigerant is leaked, together with an external ignition source, there is a possibility of ignition.
 CAUTION	This symbol shows that the Operation Instructions should be read carefully.
 CAUTION	This symbol shows that a service personnel should be handling this equipment with reference to the Installation Manual.
 CAUTION	This symbol shows that there is information included in the Operation Manual and/or Installation Manual

- Please keep this manual after reading.







PRECAUTIONS DURING INSTALLATION

 WARNING	<ul style="list-style-type: none"> ● Do not reconstruct the unit. Water leakage, fault, short circuit or fire may occur if you reconstruct the unit by yourself. 	
	<ul style="list-style-type: none"> ● Please ask your sales agent or qualified technician for the installation of your unit. Water leakage, short circuit or fire may occur if you install the unit by yourself. 	
 CAUTION	<ul style="list-style-type: none"> ● Please use earth line. Do not place the earth line near water or gas pipes, lightning-conductor, or the earth line of telephone. Improper installation of earth line may cause electric shock. 	
	<ul style="list-style-type: none"> ● A circuit breaker should be installed depending on the mounting site of the unit. Without a circuit breaker, the danger of electric shock exists. ● Do not install near location where there is flammable gas. The outdoor unit may catch fire if flammable gas leaks around it. ● Please ensure smooth flow of water when installing the drain hose. 	

PRECAUTIONS DURING SHIFTING OR MAINTENANCE

 WARNING	<ul style="list-style-type: none"> ● Should abnormal situation arises (like burning smell), please stop operating the unit and turn off the circuit breaker. Contact your agent. Fault, short circuit or fire may occur if you continue to operate the unit under abnormal situation. 	 
	<ul style="list-style-type: none"> ● Please contact your agent for maintenance. Improper self maintenance may cause electric shock and fire. 	
	<ul style="list-style-type: none"> ● Please contact your agent if you need to remove and reinstall the unit. Electric shock or fire may occur if you remove and reinstall the unit yourself improperly. 	
	<ul style="list-style-type: none"> ● If the supply cord is damaged, it must be replaced by the special cord obtainable at authorized service/parts centers. 	

PRECAUTIONS DURING OPERATION

 WARNING	<ul style="list-style-type: none"> ● Avoid an extended period of direct air flow for your health. 	
	<ul style="list-style-type: none"> ● Do not insert a finger, a rod or other objects into the air outlet or inlet. As the fan is rotating at a high speed, it will cause injury. Before cleaning, be sure to stop the operation and turn the breaker OFF. 	
	<ul style="list-style-type: none"> ● Do not use any conductor as fuse wire, this could cause fatal accident. 	
	<ul style="list-style-type: none"> ● During thunder storm, disconnect and turn off the circuit breaker. 	 

PRECAUTIONS DURING OPERATION

- The product shall be operated under the manufacturer specification and not for any other intended use.

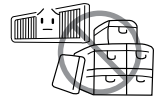

- Do not attempt to operate the unit with wet hands, this could cause fatal accident.

- When operating the unit with burning equipments, regularly ventilate the room to avoid oxygen insufficiency.

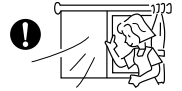

- Do not direct the cool air coming out from the air-conditioner panel to face household heating apparatus as this may affect the working of apparatus such as the electric kettle, oven etc.

- Please ensure that outdoor mounting frame is always stable, firm and without defect. If not, the outdoor unit may collapse and cause danger.



- Do not splash or direct water to the body of the unit when cleaning it as this may cause short circuit.

- Do not use any aerosol or hair sprays near the indoor unit. This chemical can adhere on heat exchanger fin and blocked the evaporation water flow to drain pan. The water will drop on tangential fan and cause water splashing out from indoor unit.

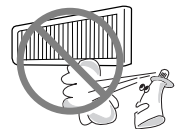

C
A
U
T
I
O
N



- Please switch off the unit and turn off the circuit breaker during cleaning, the high-speed fan inside the unit may cause danger.

- Turn off the circuit breaker if the unit is not to be operated for a long period.

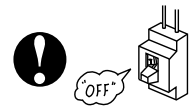

- Do not climb on the outdoor unit or put objects on it.

- Do not put water container (like vase) on the indoor unit to avoid water dripping into the unit. Dripping water will damage the insulator inside the unit and causes short-circuit.

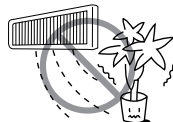

- Do not place plants directly under the air flow as it is bad for the plants.

- When operating the unit with the door and windows opened, (the room humidity is always above 80%) and with the air deflector facing down or moving automatically for a long period of time, water will condense on the air deflector and drips down occasionally. This will wet your furniture. Therefore, do not operate under such condition for a long time.

- If the amount of heat in the room is above the cooling or heating capability of the unit (for example: more people entering the room, using heating equipments and etc.), the preset room temperature cannot be achieved.

- This appliance can be used by children aged from 8 years and above and persons with reduced physical, sensory or mental capabilities or lack of experience and knowledge if they have been given supervision or instruction concerning use of the appliance in a safe way and understand the hazards involved. Children shall not play with the appliance. Cleaning and user maintenance shall not be made by children without supervision.

NAMES AND FUNCTIONS OF EACH PART

INDOOR UNIT

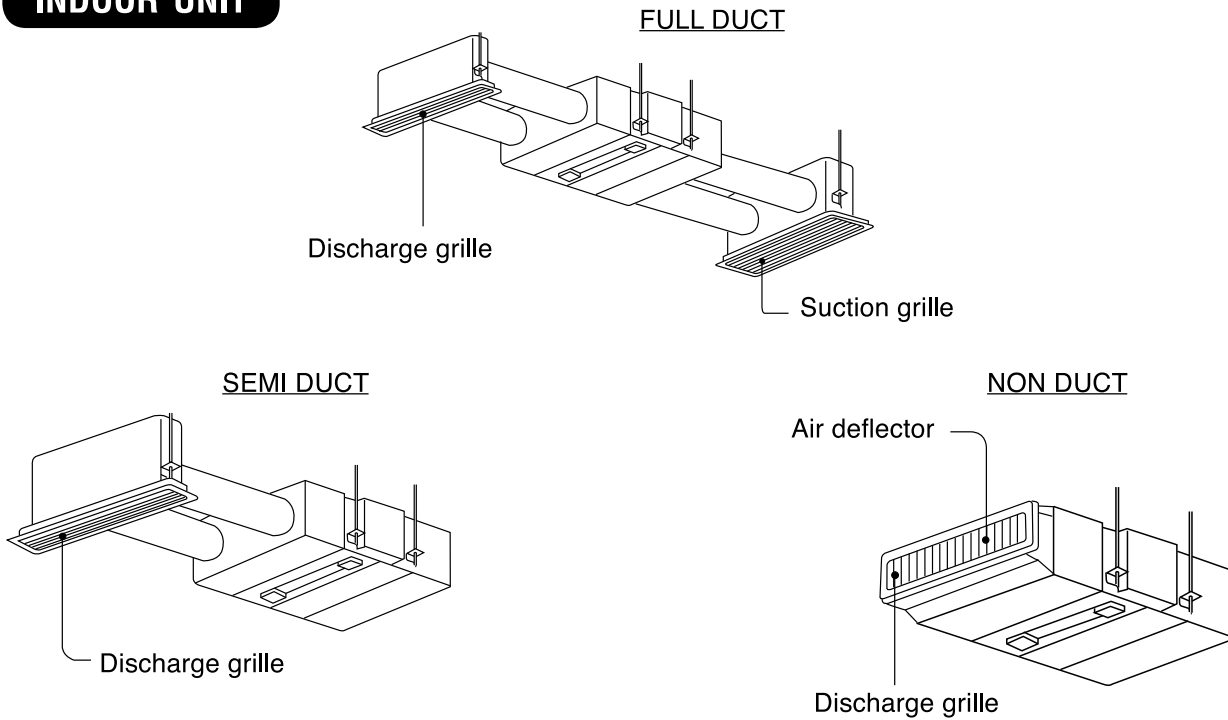

OUTDOOR UNIT

RAC-50NPD/
RAC-60NPD

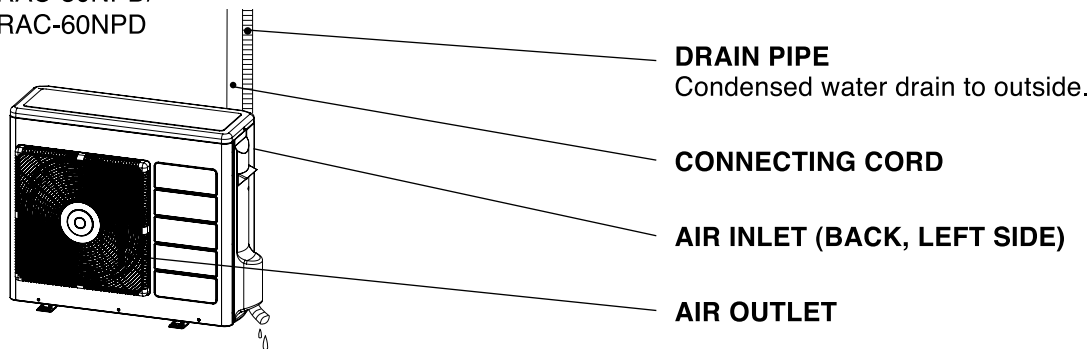

MODEL NAME AND DIMENSIONS

MODEL	WIDTH (mm)	HEIGHT (mm)	DEPTH (mm)
RAD-50PPD / RAD-60PPD	900	270	720
RAC-50NPD / RAC-60NPD	850	750	298

Note

- The recommended temperature range for safety testing should be as below:

		Cooling		Heating	
		Minimum	Maximum	Minimum	Maximum
Indoor	Dry bulb °C	21	32	20	27
	Wet bulb °C	15	23	12	19
Outdoor	Dry bulb °C	21	43	2	21
	Wet bulb °C	15	26	1	15

CIRCUIT BREAKER

When you do not use the room air conditioner, set the circuit breaker to "OFF".

HOW TO USE THE AIR CONDITIONER EFFECTIVELY

1. An average room temperature setting is probably the best for you as well as being economical.

- Excessive cooling or heating is not recommended for health reasons. High electricity bills may also result.
- Close the curtains or blinds to prevent heat from flowing into or escaping the room as well as to make more effective use of electricity.



2. At intervals, the doors and windows should be opened to let fresh air in.



Make sure the room is ventilated when operating the air conditioner at the same time as other heating appliances.



3. Using the timer is recommended before going to sleep or going out.



4. The following must never be used for cleaning the indoor and outdoor units.

- Benzine, thinner and scrub can damage plastic surfaces or coating.
- Hot water above 40°C can shrink the filter and deform plastic parts.



5. Do not block the air intake and air outlet.

- Do not block the air outlets and intakes of the indoor and outdoor units with curtains or other obstacles which could degrade air conditioner performance and cause unit failure.

THE IDEAL WAYS OF OPERATION

Suitable Room Temperature

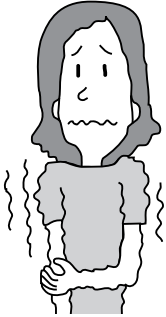

⚠ Warning

Freezing temperature is bad for health and a waste of electric power.

Install curtain or blinds

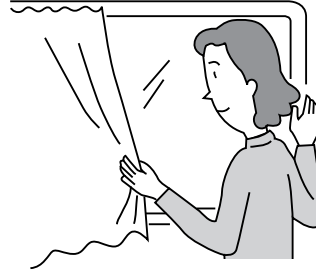

It is possible to reduce heat entering the room through windows.

Ventilation

⚠ Caution

Do not close the room for a long period of time. Occasionally open the door and windows to allow the entrance of fresh air.



Effective Usage Of Timer

At night, please use the “OFF or ON timer operation mode”, together with your wake up time in the morning. This will enable you to enjoy a comfortable room temperature. Please use the timer effectively.

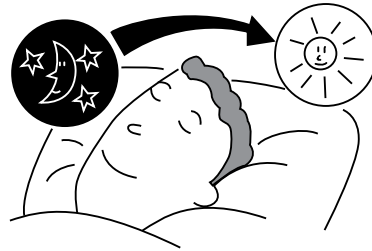

Do Not Forget To Clean The Pre-Filter

Dusty air filter will reduce the air volume and the cooling efficiency. To prevent from wasting electric energy, please clean the filter every 2 weeks.

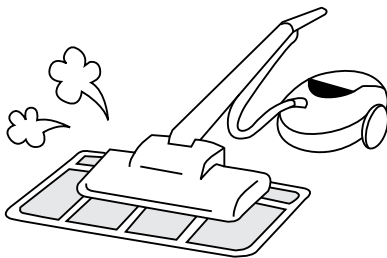

Please Adjust Suitable Temperature For Baby And Children

Please pay attention to the room temperature and air flow direction when operating the unit for baby, children and old folks who have difficulty in movement.

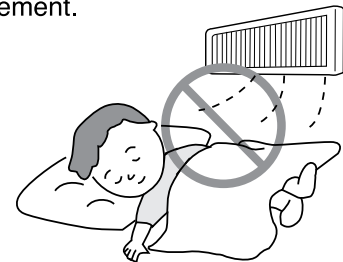

FOR USER'S INFORMATION

The Air Conditioner And The Heat Source In The Room

⚠ Caution

If the amount of heat in the room is above the cooling capability of the air conditioner (for example: more people entering the room, using heating equipments and etc.), the preset room temperature cannot be achieved.

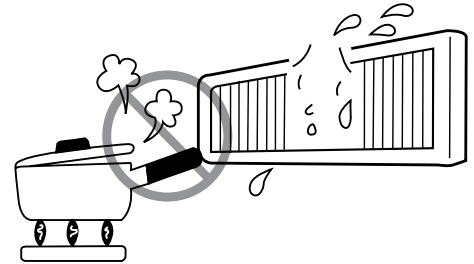

Not Operating For A Long Time

When the indoor unit is not to be used for a long period of time, please switch off the power from the mains. If the power from mains remains "ON", the indoor unit still consumes about 3W in the operation control circuit even if it is in "OFF" mode.

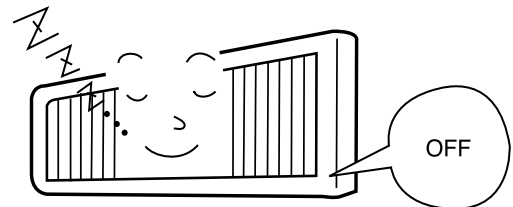

When Lightning Occurs

⚠ Warning

To protect the whole unit during lightning, please stop operating the unit and remove the plug from the socket.

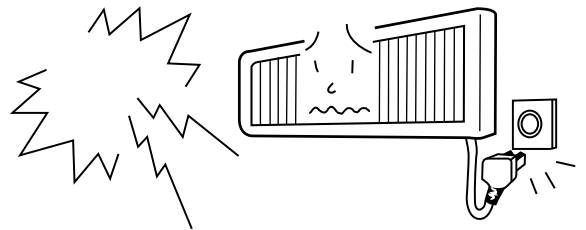

Interference From Electrical Products

⚠ Caution

To avoid noise interference, please place the indoor unit and its remote controller at least 1m away from electrical products.

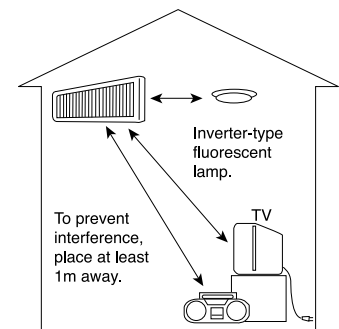

MAINTENANCE

⚠ WARNING

- Before cleaning, stop unit operation with the remote controller and turn off the circuit breaker.

⚠ CAUTION

- Do not expose the unit to water as it may cause an electric shock.
- For cleaning inside the air conditioner, consult your sales agent.
- Avoid using detergent when cleaning the heat exchanger of the indoor unit. Unit failure may result.
- When cleaning the heat exchanger with a vacuum cleaner, make sure to wear gloves so as not to injure your hands on the heat exchanger fins.

1. PRE-FILTER

Clean the pre-filter, as it removes dust inside the room. Be sure to clean the filter once every two weeks so as not to consume electricity unnecessarily.

PROCEDURE

- 1** Pull the filter toward the center until it detached from the holders. Then take it out from holders (refer to diagram).

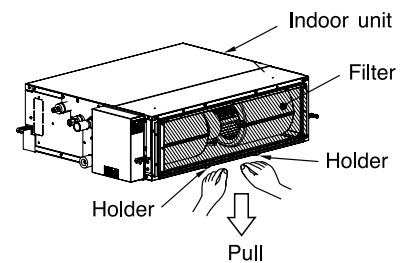

- 2** Remove dust from the filter using a vacuum cleaner. If there is too much dust, wipe the filter with wet cloth or sponge. Allow filter to dry in shade.



- 3** Install the filters. Gently insert back the filter into the holders.

⚠ CAUTION

- Do not wash with hot water at more than 40°C. The filter may shrink.
- Do not operate the air conditioner with the filter removed. Dust may enter the air conditioner and cause trouble.

REGULAR INSPECTION

PLEASE CHECK THE FOLLOWING POINTS BY QUALIFIED SERVICE PERSONNEL EITHER EVERY HALF YEARLY OR YEARLY. CONTACT YOUR SALES AGENT OR SERVICE SHOP.

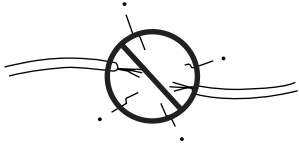
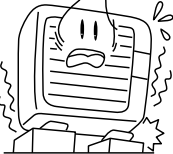
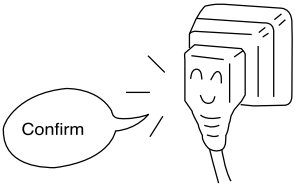
1		Is the earth line disconnected or broken?
2		Is the mounting frame seriously affected by rust and is the outdoor unit tilted or unstable?
3		Is the plug of power line firmly plugged into the socket? (Please ensure no loose contact between them).

AFTER SALE SERVICE AND WARRANTY

WHEN ASKING FOR SERVICE, CHECK THE FOLLOWING POINTS.

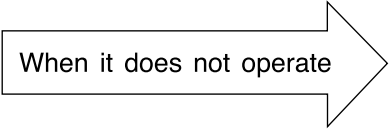
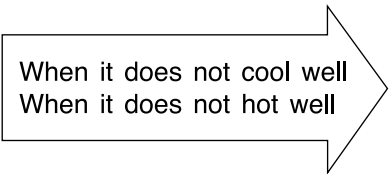
CONDITION	CHECK THE FOLLOWING POINTS
	<ul style="list-style-type: none"> ● Is the fuse all right? ● Is the voltage extremely high or low? ● Is the circuit breaker "ON"?
	<ul style="list-style-type: none"> ● Was the air filter cleaned? ● Does sunlight fall directly on the outdoor unit? ● Is the air flow of the outdoor unit obstructed? ● Are the doors or windows opened, or is there any source of heat in the room? ● Is the set temperature suitable?













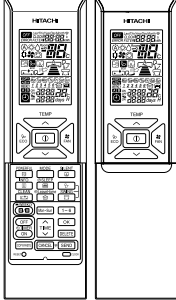









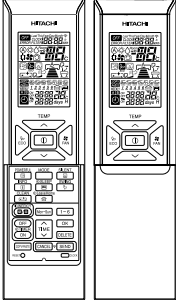







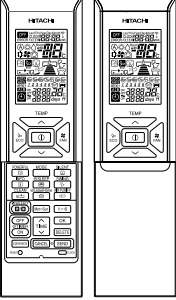









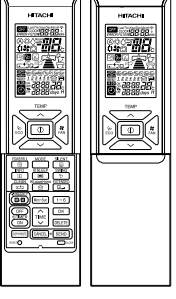





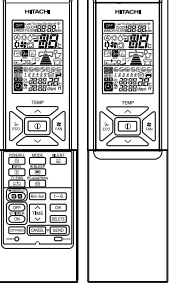

Notes

- In quiet or stop operation, the following phenomena may occasionally occur, but they are not abnormal for the operation.
 - (1) Slight flowing noise of refrigerant in the refrigerating cycle.
 - (2) Slight rubbing noise from the fan casing which is cooled and then gradually warmed as operation stops.
- The odor will possibly be emitted from the room air conditioner because the various odor, emitted by smoke, foodstuffs, cosmetics and so on, sticks to it. So the air filter and the evaporator regularly must be cleaned to reduce the odor.

- Please contact your sales agent immediately if the air conditioner still fails to operate normally after the above inspections. Inform your agent of the model of your unit, production number, date of installation. Please also inform him regarding the fault.
- Power supply shall be connected at the rated voltage, otherwise the unit will be broken or could not reach the specified capacity.

PRECAUTIONS FOR USE

- In case of power failure happen, Wired Remote Controller may not show current operating mode when power comes back. However unit will continue to operate at previous setting mode.
- Some features of Wireless Remote Controller are not available when use Wired Remote Controller as mentioned below:

Standard Wireless Remote Controller	Features not available on Wired Remote Controller
<p>RAR-6N1</p> 	<ul style="list-style-type: none"> • Powerful  • Information  • One touch clean  • Leave home  • Silent  • Weekly timer  • Auto swing (vertical)  • Auto swing (horizontal)  • ECO 
<p>RAR-6N2</p> 	<ul style="list-style-type: none"> • Powerful  • Information  • One touch clean  • Leave home  • Silent  • Weekly timer  • Auto swing (vertical)  • ECO 
<p>RAR-6N3</p> 	<ul style="list-style-type: none"> • Powerful  • Information  • One touch clean  • Leave home  • Silent  • Weekly timer  • Auto swing (vertical)  • Air purify  • ECO 
<p>RAR-6N4</p> 	<ul style="list-style-type: none"> • Powerful  • Information  • One touch clean  • Leave home  • Silent  • Weekly timer  • Auto swing (vertical)  • Extended  • ECO 
<p>RAR-6N5</p> 	<ul style="list-style-type: none"> • Powerful  • Information  • One touch clean  • Leave home  • Silent  • Weekly timer  • ECO 

NAMES AND FUNCTIONS OF REMOTE CONTROLLER

■ This controls the operation function and timer setting of the room air conditioner.

OPERATION LAMP

START/STOP Button

Press this button to start operation.
Press it again to stop operation.

MODE SELECTOR Button

Use this button to select the operating mode. Every time you press it, the mode will change from (A) (AUTO) to (HEAT) to (DEHUMIDIFY) and to (COOL) cyclically.

SLEEP Button

Use this button to set the sleep timer. (Page 25)

SET Button

Timer setting reservation.

OFF TIMER Button

Select the turn OFF timer.

ON TIMER Button

Select the turn ON timer.

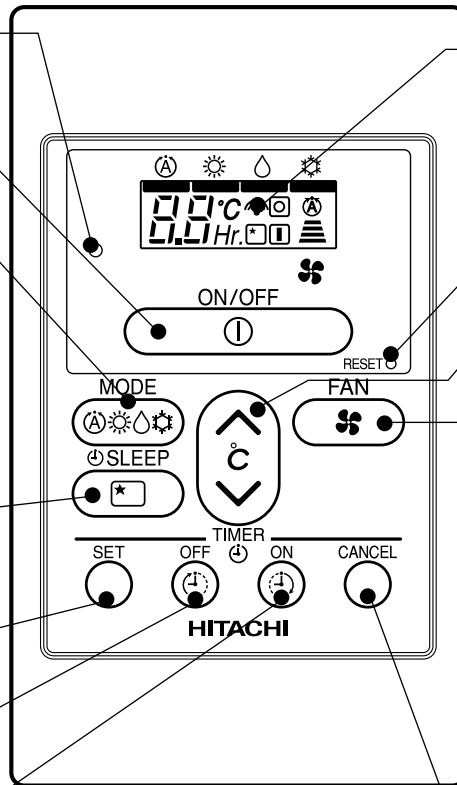

Transmission Sign

The transmission sign blinks when a signal has been send.

RESET SWITCH

ROOM TEMPERATURE Setting Button

Room temperature setting. Value will change quicker when keep pressing.

FAN SPEED Button

This determines the fan speed. Every time you press this button, the intensity of circulation will change from (A) (AUTO) to (HIGH) to (MED) to (LOW) to (SILENT)(This button allows selecting the optimal or preferred fan speed for each operation mode).

CANCEL Button

Cancel timer reservation.

Precautions for Use

- Do not put the remote controller in the following places.
 - Under direct sunlight.
 - In the vicinity of a heater.
- Handle the remote controller carefully. Do not drop it on the floor, and protect it from water.
- Once the outdoor unit stops, it will not restart for about 3 minutes (unless you turn the power switch off and on or unplug the power cord and plug it in again).
This is to protect the device and does not indicate a failure.
- If you press the MODE SELECTOR button during operation, the device may stop for about 3 minutes for protection.

VARIOUS FUNCTIONS

Auto Restart Control

- If there is a power failure, operation will be automatically restarted when the power is resumed with previous operation mode.
(As the operation is not stopped by remote controller.)
 - If you intend not to continue the operation when the power is resumed, switch off the power supply. When you switch on the circuit breaker, the operation will be automatically restarted with previous operation mode.
- Note: 1. If you do not require Auto Restart Control, please consult your sales agent.
2. Auto Restart Control is not available when Timer or Sleep Timer mode is set.

AUTOMATIC OPERATION

The device will automatically determine the mode of operation, HEAT or COOL depending on the current room temperature. The selected mode of operation will change when the room temperature varies.

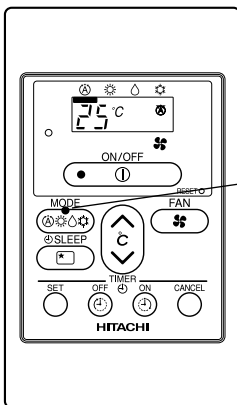

1

Press the MODE selector button so that the display indicates the **(A)** (AUTO) mode of operation.

- When AUTO has been selected, the device will automatically determine the mode of operation, HEAT or COOL depending on the current room temperature.
- If the mode automatically selected by the unit is not satisfactory, manually change the mode setting (HEAT, DEHUMIDIFY or COOL).

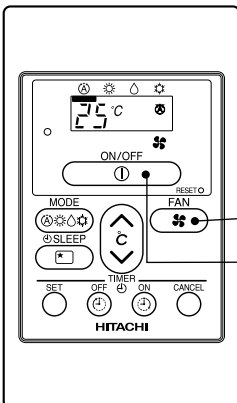

2

Press the **(FAN SPEED)** button to select AUTO, HIGH, MED, LOW or SILENT.

Set the desired FAN SPEED with the **(FAN SPEED)** button (the display indicates the setting).

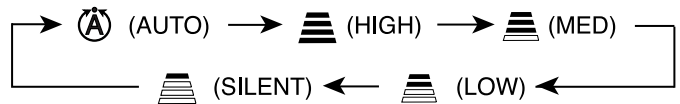

**START
STOP**

Press the **(START/STOP)** button.
Operation starts.
Press the button again to stop operation.

- As the settings are stored in the memory in the remote controller, you only have to press the **(START/STOP)** button next time.

HEATING OPERATION

- Use the device for heating when the outdoor temperature is under 21°C.
When it is too warm (over 21°C), the heating function may not work in order to protect the device.
- In order to maintain reliability of the device, please use this device when outdoor temperature is above -15°C

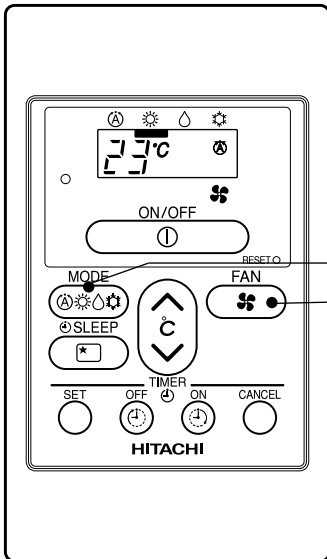

1

Press the MODE SELECTOR button so that the display indicates ☀ (HEAT).

2

Set the desired FAN SPEED with the 🌀 (FAN SPEED) button (the display indicates the setting).

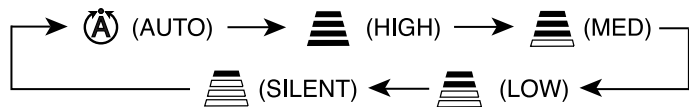

3

Set the desired room temperature with the ROOM TEMPERATURE setting button (the display indicates the setting).

The temperature setting and the actual room temperature may vary depending on conditions.

**START
STOP**

Press the ⏻ (START/STOP) button. Heating operation starts. Press the button again to stop operation.

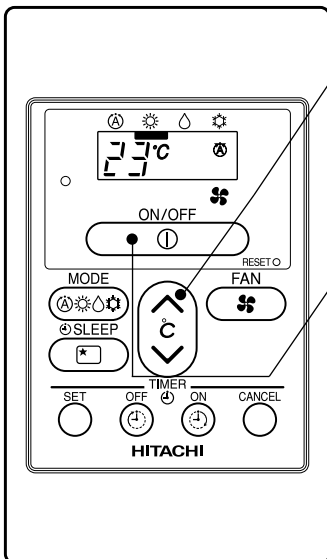

- As the settings are stored in the memory of the remote controller, you only have to press the ⏻ (START/STOP) button next time.
- During AUTO fan, the fan speed automatically changes as below:
 - When the difference between room temperature and setting temperature is large, fan starts to run at HI speed.
 - After room temperature reaches the preset temperature, fan speed will be changed to lower speed to obtain optimum room temperature condition for natural healthy heating.

Defrosting

Defrosting will be performed about once an hour when frost forms on the heat exchange of the outdoor unit, for 5~10 minutes each time.

During defrosting operation, the operation lamp blinks / dimming in a cycle of 3 seconds on and 0.5 second off. The maximum time for defrosting is 20 minutes.

(If the piping length used is longer than usual, frost is likely to form.)

DEHUMIDIFYING OPERATION

Use the device for dehumidifying when the room temperature is over 16°C.
When it is under 15°C, the dehumidifying function will not work.

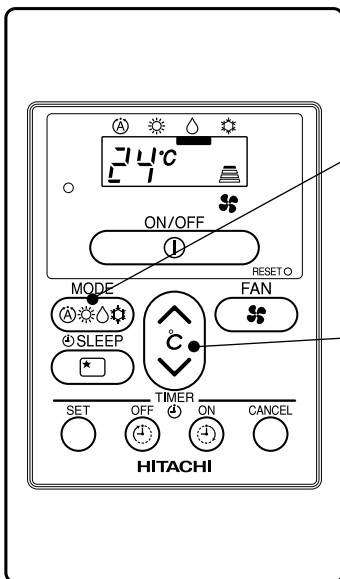

1

Press the MODE SELECTOR button so that the display indicates ◊ (DEHUMIDIFY).
Press  (FAN SPEED) button to select SILENT or LOW fan speed.

2

Set the desired room temperature with the ROOM TEMPERATURE setting button (the display indicates the setting).

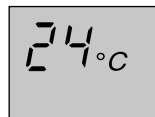

The range of 20-26°C is recommended as the room temperature for dehumidifying.

**START
STOP**

Press the  (START/STOP) button. Dehumidifying operation starts. Press the button again to stop operation.

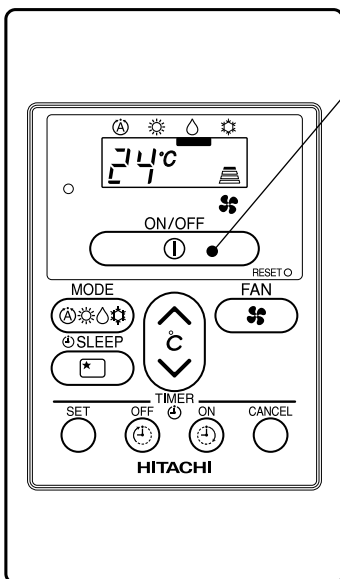

■ As the settings are stored in the memory in the remote controller, you only have to press the  (START/STOP) button next time.

■ Dehumidifying Function

- When the room temperature is higher than the temperature setting: The device will dehumidify the room, reducing the room temperature to the preset level.
When the room temperature is lower than the temperature setting: Dehumidifying will be performed at the temperature setting slightly lower than the current room temperature, regardless of the temperature setting.
- The preset room temperature may not be reached depending on the number of people present in the room or other room conditions.

COOLING OPERATION

Use the device for cooling when the outdoor temperature is $-15 \sim 43^{\circ}\text{C}$.
 If indoor humidity is very high (80%), some dew may form on the air outlet grille of the indoor unit.

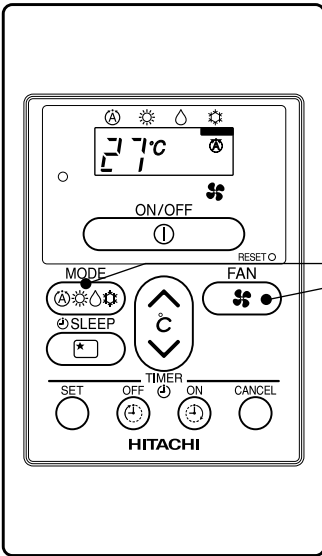

1 Press the MODE SELECTOR button so that the display indicates (COOL).

2 Set the desired FAN SPEED with the (FAN SPEED) button (the display indicates the setting).

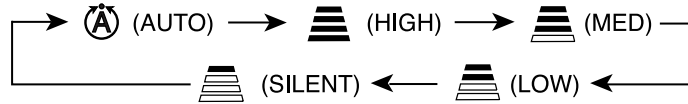

3 Set the desired room temperature with the ROOM TEMPERATURE setting button (the display indicates the setting).

The temperature setting and the actual room temperature may vary depending on conditions.

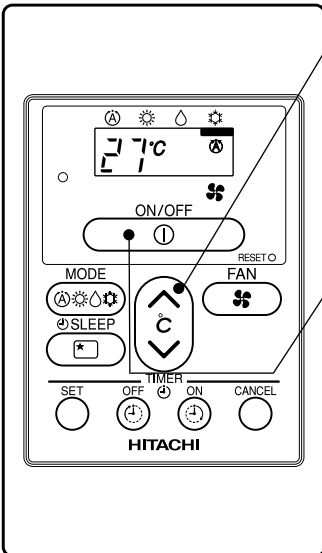

START STOP Press the (START/STOP) button. Cooling operation starts. Press the button again to stop operation. The cooling function does not start if the temperature setting is higher than the current room temperature (even though the (OPERATION) lamp lights). The cooling function will start as soon as you set the temperature below the current room temperature.



- As the settings are stored in the memory of the remote controller, you only have to press the (START/STOP) button next time.
- During AUTO fan, the fan speed automatically changes as below:
 - When the difference between room temperature and setting temperature is large, fan starts to run at HI speed.
 - After room temperature reaches the preset temperature, fan speed will be changed to lower speed to obtain optimum room temperature condition for natural healthy cooling.



LEAVE HOME(LH) AND CLEAN (ONE TOUCH CLEAN) OPERATIONS

- Leave Home (LH) and CLEAN(One Touch Clean) operations activation buttons are not available on this device. The operations shall be activated by wireless remote controller.
- Please refer to wireless 'Remote Controller Manual' to activate the operations.

NOTE

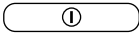
- If  or  is displayed on the wired remote controller display, the unit will operate Leave Home (LH) operation mode or CLEAN (One Touch Clean) which shall be activated by wireless remote controller.
- Push start/stop  button to stop Leave Home (LH) or CLEAN (One Touch Clean) operation.

TIMER RESERVATION

■ ON Timer and OFF Timer are available.

OFF Timer Reservation

1 ⌚ OFF TIMER setting

- Select the OFF TIMER by pressing the ⌚ (OFF) Button.
- Setting timer will change according to the below sequence when you press the button.

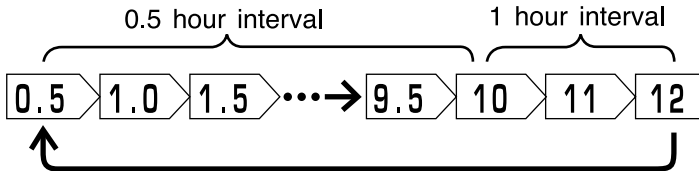

- The value change quicker if you keep pressing the button.

2 Press the ○ (SET) button

- OFF TIMER is reserved.
- The ☐ (OFF) Mark starts lighting instead of blinking.

ON Timer Reservation

1 ⌚ ON TIMER setting

- Select the ON TIMER by pressing the ⌚ (ON) Button.
- At the beginning of setting, timer is set to 6 hours.
- Setting timer will change according to the below sequence.

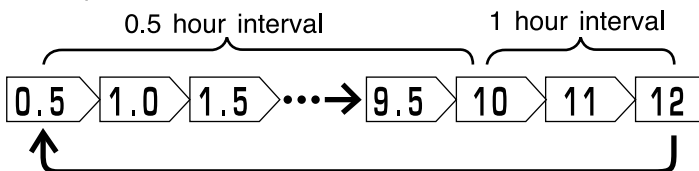

- The value change quicker if you keep pressing the button.

2 Press the ○ (SET) button

- ON TIMER is reserved.
- The □ (ON) Mark starts lighting instead of blinking.

CANCELLATION of Timer Reservation

1 Press the ○ (CANCEL) button

- As the timer settings are stored in remote controller memory, you only have to press the ○ (SET) button in order to use the same setting next time.

■ Operation stop at setting timer

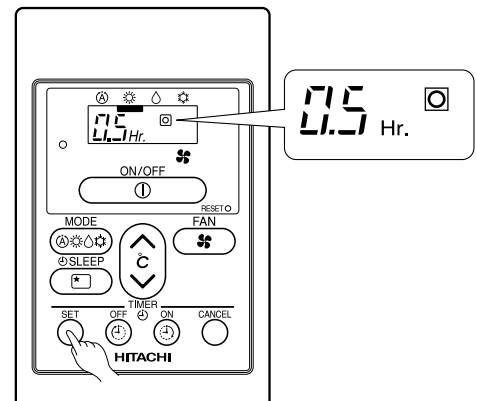
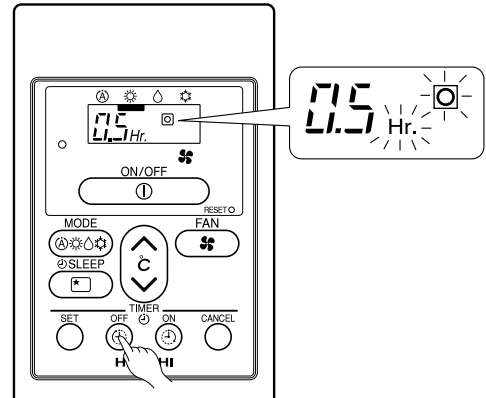

■ Operation will start for setting temperature at setting timer (The starting time may different depend on the room temperature and set temperature).

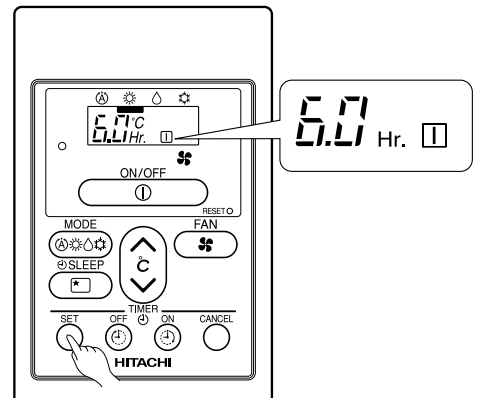
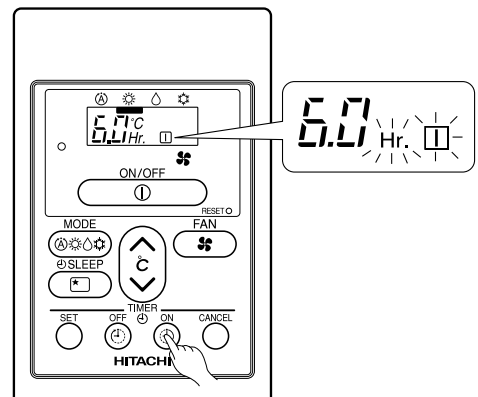

HOW TO SET THE SLEEP TIMER

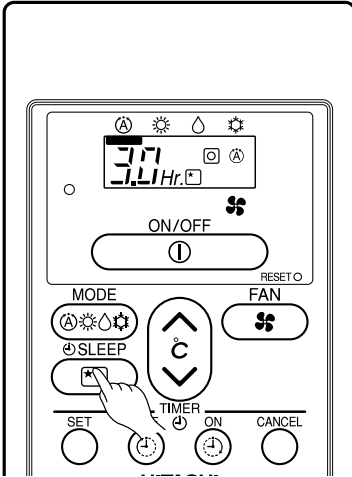

Example: Setting 3 hours sleep timer.

Mode	Indication
Sleep timer	

Sleep Timer: The device will continue working for the designated number of hours and then turn off.
 Press the SLEEP button.
 The timer information will be displayed on the remote controller.

How to Cancel Reservation

Press the ○ (CANCEL) button. The ◯ and ★ (RESERVED) sign goes out.

Explanation of the sleep timer

The device will control the FAN SPEED and room temperature automatically so as to be quiet and good for people's health.

NOTE

- If you set the sleep timer after the off or on-timer has been set, the sleep timer becomes effective instead of the off or on-timer set earlier.
- You can not set other timer during sleep timer operation.
- After sleep timer time is up and when press sleep button again, the sleep timer will be set as last setting.
- Sleep timer effective only once.

INSTALLATION OF WIRED REMOTE CONTROLLER

- (a) Connection to the electrical box;
- Remove the cover of electric box
 - Connect the connector of wired remote controller to CN1102 of electrical board
 - Assemble back the cover of electrical box
- (b) Wiring installation for wired remote controller (2 methods);
- Wired remote controller casing can be opened by pressing the slots with minus screw driver (see below diagram)

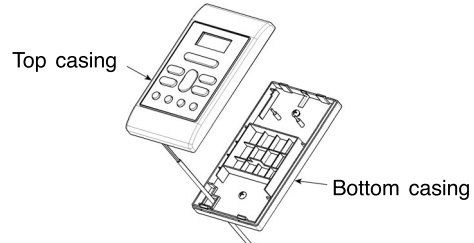
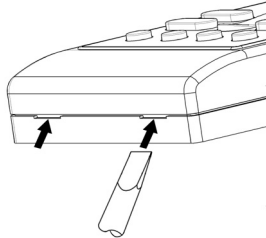

- Decide the fixing location of remote controller so that the length of wire shall be within 5 meters.

CAUTION

- Do not cut the provided wire. Excess wire should be properly wound and fitted at safe place.
- Do not join the wire with additional wire.

Wiring installation illustrations

Wall recessed wiring installation (Supplied)

1. When connecting the wires via the wall's recessed slot;
 - Fix the bottom casing to the wall by provided screw.
 - Assemble the top casing to the fixed bottom casing.
(Refer to the illustration below for detail installation)

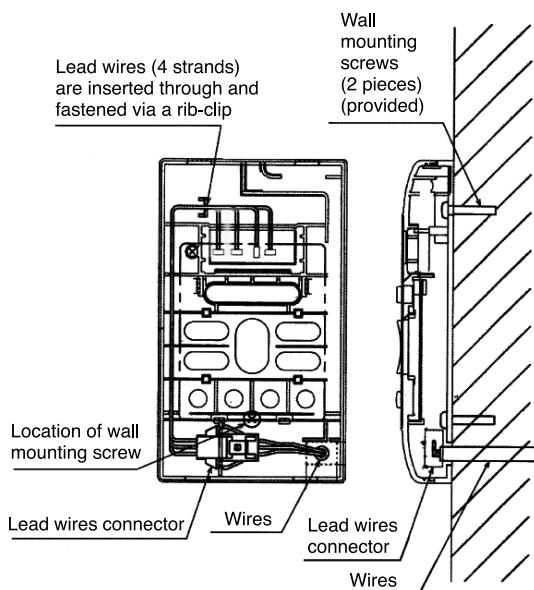

Inside top wiring installation (Alternative)

2. When the wires to be connected from the inside top portion of top casing;
 - Break off a perforated aperture located at the top portion of the bottom casing by nipper. Smoothen the aperture by cutter.
 - Fix the bottom casing to the wall by provided screw.
 - Connect the wires to the lead wires connector.
 - Mount the wires through the provided slot on top casing.
 - Assemble the top casing to the fixed bottom casing
(Refer to the illustration below for detail installation)

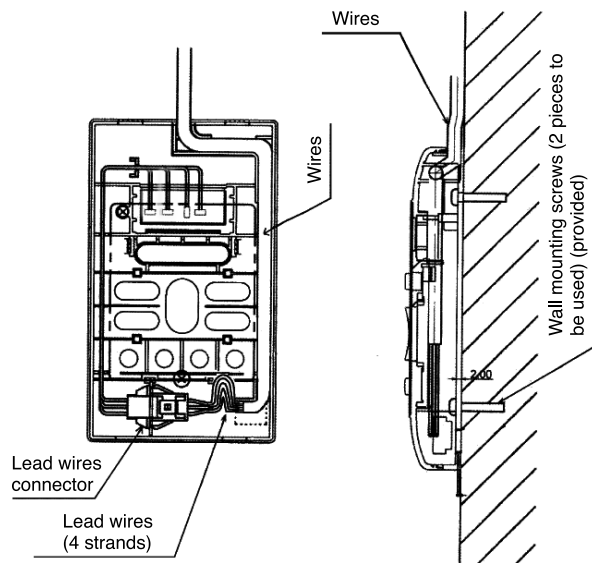

PREPARATION BEFORE OPERATION

■ To install the batteries

1. Slide the cover to take it off.
2. Install two dry batteries AAA.LR03 (alkaline).
The direction of the batteries should match the marks in the case.
3. Replace the cover at its original position.

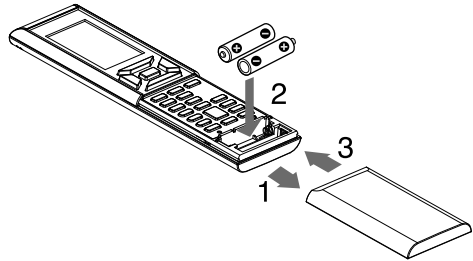

■ To fix the remote controller holder to the wall

1. Choose a place from where the signals can reach the unit.
2. Fix the remote controller holder to a wall, a pillar or similar location with the provided screws.
3. Place the remote controller in the remote controller holder.

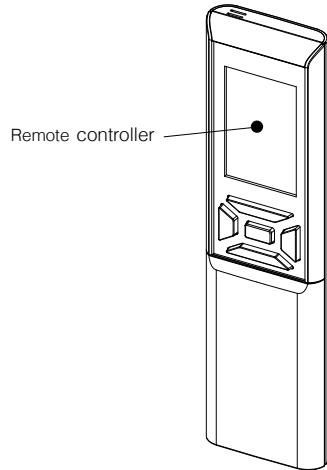

NOTE

Notes on batteries

- When replacing the batteries, use batteries of the same type, and replace both old batteries together.
- When the system is not used for a long time, take the batteries out.
- The batteries will last for approximately 1 year. However, if the remote controller display begins to fade and degradation of reception performance occurs within a year, replace both batteries with new size AAA.LR03 (alkaline).
- The usable period of the batteries may be short depending on the manufactured date of the air conditioner.

Notes on the remote controller

- Never expose the remote controller to direct sunlight.
- Dust on the signal transmitter or receiver will reduce the sensitivity. Wipe off dust with soft cloth.
- Signal communication may be disabled if an electronic-starter-type fluorescent lamp (such as inverter-type lamps) is in the room. Consult the shop if that is the case.
- If the remote controller signals happen to operate another appliance, move that appliance to somewhere else, or consult the service shop.
- When the remote controller is not in use, please close the slide cover to prevent failure.

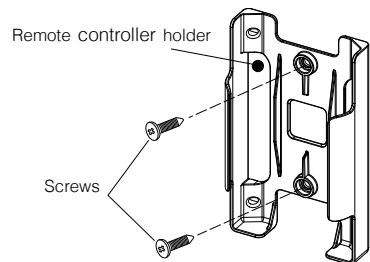

PREPARATION BEFORE OPERATION

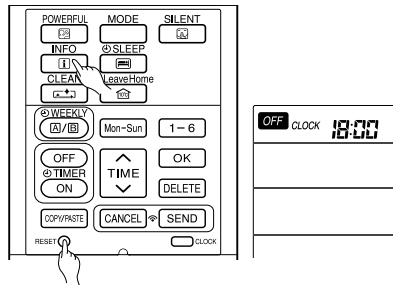
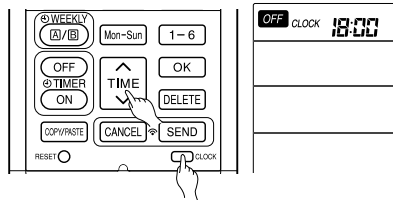
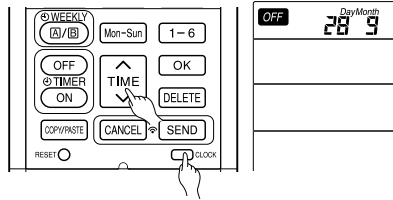
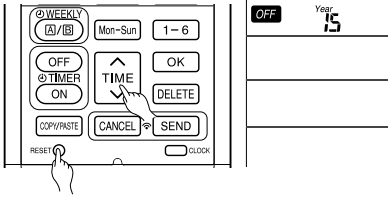

To set calendar and clock

1. Press **RESET** (RESET) button when first time setting. "Year" blinks.
 2. Press **TIME** (TIME) button to set the current year.
 3. Press **CLOCK** (CLOCK) button. "Day" and "Month" blink.
 4. Press **TIME** (TIME) button to set the current day and month.
 5. Press **CLOCK** (CLOCK) button. "CLOCK" blinks.
 6. Press **TIME** (TIME) button to set the clock to the current time.
 7. Press **CLOCK** (CLOCK) button.
- Calendar and clock are set.

To modify the calendar and clock, press **CLOCK** (CLOCK) button.
Then follow steps 1 to 7.

Calendar and clock need to be set again after changing batteries.

After changing the batteries,

1. Press **RESET** (RESET) button.
2. Direct remote controller towards indoor unit and press **INFO** (INFO) button.
3. The calendar and clock from indoor unit will be transmitted.

- Calendar and clock will not be transmitted from indoor unit when the following occurs:
 - When there is a power failure.
 - When breaker is OFF by user (unit is not in STANDBY MODE).

NOTE

Note on setting the calendar and clock.

- If the calendar and clock are not set, the ON-timer, OFF-timer and Weekly Timer cannot be set.
- If the calendar and clock are not set correctly, the ON-timer, OFF-timer and Weekly Timer will not operate correctly.
- When the ON-timer, OFF-timer and Weekly Timer are set, the calendar and clock cannot be changed. If there is a need to change the calendar and clock, ON-timer, OFF-timer and Weekly Timer need to be cancelled.

NAMES AND FUNCTIONS OF REMOTE CONTROLLER

REMOTE CONTROLLER

- This controls the operation of the indoor unit. The range of control is about 7 meters. If indoor lighting is controlled electronically, the range of control may be shorter.
This unit can be fixed on a wall using the fixture provided. Before fixing it, make sure the indoor unit can be controlled from the remote controller.
- Handle the remote controller with care. Dropping it or getting it wet may compromise its signal transmission capability.
- After new batteries are inserted into the remote controller, the unit will initially require approximately 10 seconds to respond to commands and operate.
- When remote controller is not in use for about 3 minutes during OFF condition, indicated by **OFF** on the display, the LCD will turn off.
- During clock setting, the LCD will turn off about 10 minutes later if the remote controller is not in use.
- When pressing any button, the LCD will turn on.
- The LCD will not turn off during TIMER setting.

Signal Transmitting/Receiving Window

Point this window towards the indoor unit when controlling it.

Sensor

A temperature sensor inside the remote controller senses ambient temperature around the remote-controller.

Display

This indicates the room temperature selected, current time, timer status, function and airflow rate selected.

ROOM TEMPERATURE setting Buttons

Press these buttons to set the room temperature.

Press the [\wedge] button to raise the room temperature.

Press the [\vee] button to lower the room temperature.

Keep pressing and the value will change more quickly.

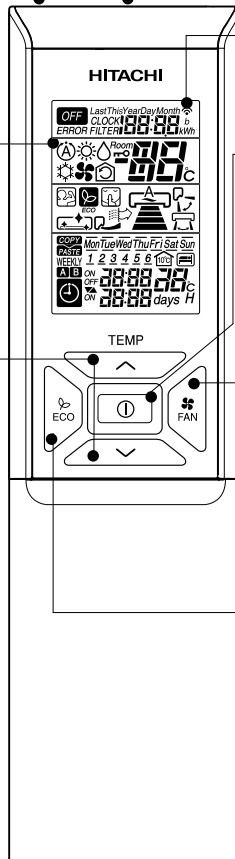

Transmission sign

The transmission sign lights up when a signal is sent.

START/STOP button

Press this button to start operation. Press it again to stop operation.

FAN SPEED selector Button

This determines the fan speed. Every time you press this button, the airflow rate will change from (AUTO) → (HIGH) → (MED) → (LOW) → (SILENT) (This button allows selection of optimal or preferred fan speed for each operation mode).

ECO Button

Use this button to set the ECO mode. (▶ p. 13)

NAMES AND FUNCTIONS OF REMOTE CONTROLLER

POWERFUL Button

Use this button to set the POWERFUL mode. (▶ p. 11)

INFORMATION Button

(▶ p. 25)

ONE TOUCH CLEAN Button

(▶ p. 15)

LEAVE HOME Button

(▶ p. 14)

ECO SLEEP TIMER Button

Use this button to set the ECO sleep timer. (▶ p. 17)

MODE selector Button

Use this button to select the operating mode. Every time you press this button, the mode will change from (A) (AUTO) → (HEAT) → (DEHUMIDIFY) → (COOL) and → (FAN) cyclically.

SILENT Button

Use this button to set the SILENT mode. (▶ p. 12)

WEEKLY TIMER setting Buttons

(▶ p. 19)

ON / OFF TIMER setting Buttons

(▶ p. 16)

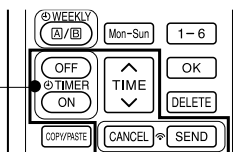
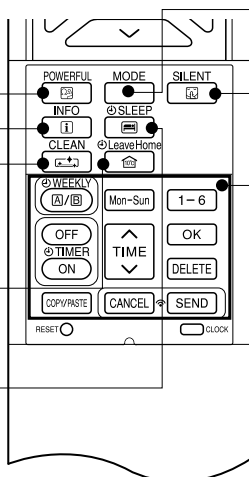

MODE	MODE SELECTOR
(A)	AUTO
(HEAT)	HEAT
(DEHUMIDIFY)	DEHUMIDIFY
(COOL)	COOL
(FAN)	FAN
A	FAN SPEED
	AUTO
	SILENT
	LOW
①	MED
	HIGH
①	START / STOP

(ECO)	ECO
(FAN)	FAN
(POWERFUL)	POWERFUL
(SILENT)	SILENT
(INFO)	INFO
(SLEEP)	SLEEP TIMER
(LEAVE HOME)	LEAVE HOME
(CLEAN)	CLEAN
Mon-Sun	DAY
1-6	PROGRAM NO.

(OFF / ON)	ON / OFF TIMER
(TIME)	TIME
(OK)	OK
(DELETE)	DELETE
(COPY/PASTE)	COPY / PASTE
(CANCEL)	CANCEL
(SEND)	SEND
(CLOCK)	CLOCK

Precautions for Use

- Do not put the remote controller in the following places.
 - Under direct sunlight.
 - In the vicinity of a heater.
- Handle the remote controller carefully. Do not drop it on the floor, and protect it from water.
- Once the outdoor unit stops, it will not restart for about 3 minutes (unless you turn the power switch off and on or unplug the power cord and plug it in again). This is to protect the device and does not indicate a failure.
- If you press the MODE selector button during operation, the device may stop for about 3 minutes for protection.

VARIOUS FUNCTIONS

Auto Restart Control

- If there is a power failure, operation will be automatically restarted when the power is resumed with previous operation mode and airflow direction.
(As the operation is not stopped by remote controller.)
- If you intend not to continue the operation when the power is resumed, switch off the power supply.
When you switch on the circuit breaker, the operation will be automatically restarted with previous operation mode and airflow direction.

Note: 1. If you do not require Auto Restart Control, please consult your sales agent.

2. Auto Restart Control is not available when Timer or Sleep Timer mode is set.

AUTOMATIC OPERATION

The device will automatically determine the mode of operation, HEAT or COOL depending on the current room temperature. The selected mode of operation will change when the room temperature varies. However, the mode of operation will not change when indoor unit is connected to multi type outdoor unit.

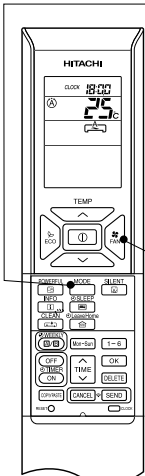

1

Press the MODE selector button so that the display indicates the  (AUTO) mode of operation.

- When AUTO has been selected, the device will automatically determine the mode of operation, HEAT or COOL depending on the current room temperature. However the mode of operation will not change when indoor unit is connected to multi type outdoor unit.
- If the mode automatically selected by the unit is not satisfactory, manually change the mode setting (HEAT, DEHUMIDIFY, COOL or FAN).

2

Set the desired FAN SPEED with the  (FAN SPEED) button (the display indicates the setting).

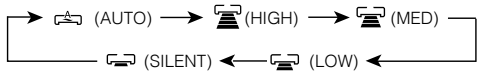

3

Set the desired room temperature with the TEMPERATURE buttons (the display indicates the setting).

The temperature setting and the actual room temperature may vary depending on conditions.

Temperature range can be set between 16°C and 32°C.

START STOP

Press the  (START/STOP) button.

Operation starts with a beep.

Press the button again to stop operation.

- As the settings are stored in the memory of the remote controller, you only have to press the  (START/STOP) button next time.

Press the  (FAN SPEED) button to select AUTO, HIGH, MED, LOW or SILENT.

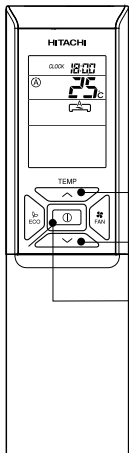

HEATING OPERATION

- Use the device for heating when the outdoor temperature is under 21°C. When it is too warm (over 21°C), the heating function may not work in order to protect the device.
- In order to maintain reliability of the device, please use this device when outdoor temperature is above -15°C.

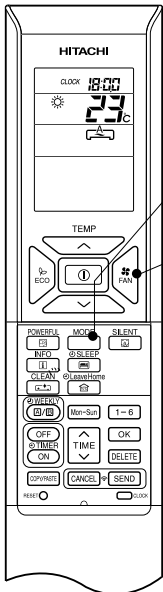

1

Press the MODE selector button so that the display indicates  (HEAT).

2

Set the desired FAN SPEED with the  (FAN SPEED) button (the display indicates the setting).

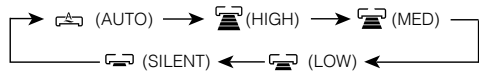

3

Set the desired room temperature with the TEMPERATURE buttons (the display indicates the setting).

The temperature setting and the actual room temperature may vary depending on conditions.

Temperature range can be set between 16°C and 32°C.

START STOP

Press the  (START/STOP) button. Heating operation starts with a beep. Press the button again to stop operation.

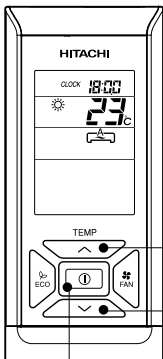

- As the settings are stored in the memory of the remote controller, you only have to press the  (START/STOP) button next time.

- During AUTO fan, the fan speed automatically changes as below:
 - When the difference between room temperature and setting temperature is large, fan starts to run at HI speed.
 - After room temperature reaches the preset temperature, fan speed will be changed to lower speed to obtain optimum room temperature condition for natural healthy heating.

Defrosting

Defrosting will be performed about once an hour when frost forms on the heat exchange of the outdoor unit, for 5-10 minutes each time.

During defrosting operation, the operation lamp blinks in a cycle of 3 seconds on and 0.5 second off.

The maximum time for defrosting is 20 minutes.

However, if the indoor unit is connected to multi type outdoor unit, the maximum time for defrosting is 15 minutes.

(If the piping length used is longer than usual, frost is likely to form.)

DEHUMIDIFYING OPERATION

Use the device for dehumidifying when the room temperature is over 16°C.
When it is under 15°C, the dehumidifying function will not work.

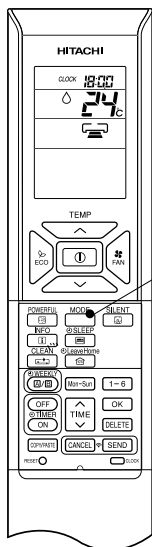

1

Press the MODE selector button so that the display indicates ◊ (DEHUMIDIFY).
The fan speed is set at LOW.
Press  (FAN SPEED) button to select SILENT or LOW fan speed.

2

Set the desired room temperature with the ROOM TEMPERATURE setting buttons (the display indicates the setting).

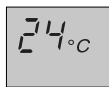

The range of 20-26°C is recommended as the room temperature for dehumidifying.
Temperature range can be set between 16°C and 32°C.

**START
STOP**

Press the  (START/STOP) button. Dehumidifying operation starts with a beep. Press the button again to stop operation.

- As the settings are stored in the memory of the remote controller, you only have to press the  (START/STOP) button next time.

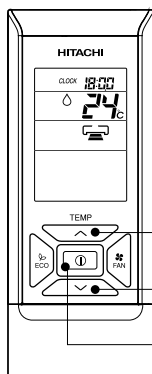

■ Dehumidifying Function

- When the room temperature is higher than the temperature setting: The device will dehumidify the room, reducing the room temperature to the preset level.
When the room temperature is lower than the temperature setting: Dehumidifying will be performed at the temperature setting slightly lower than the current room temperature, regardless of the temperature setting.
- The preset room temperature may not be reached depending on the number of people present in the room or other room conditions.

COOLING OPERATION

Use the device for cooling when the outdoor temperature is -10~43°C.

If indoors humidity is very high (80%), some dew may form on the air outlet grille of the indoor unit.

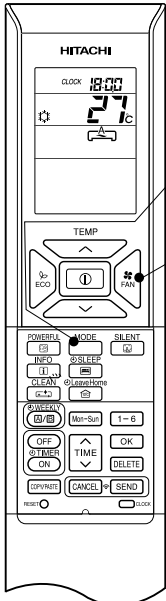

1

Press the MODE selector button so that the display indicates (COOL).

2

Set the desired FAN SPEED with the (FAN SPEED) button (the display indicates the setting).

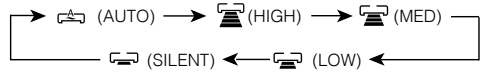

3

Set the desired room temperature with the TEMPERATURE buttons (the display indicates the setting).

The temperature setting and the actual room temperature may vary depending on conditions.
Temperature range can be set between 16°C and 32°C.

**START
STOP**

Press the (START/STOP) button. Cooling operation starts with a beep. Press the button again to stop operation. The cooling function does not start if the temperature setting is higher than the current room temperature (even though the (OPERATION) lamp lights). The cooling function will start as soon as user set the temperature below the current room temperature.

- As the settings are stored in the memory of the remote controller, you only have to press the (START/STOP) button next time.
- During AUTO fan, the fan speed automatically changes as below:
 - When the difference between room temperature and setting temperature is large, fan starts to run at HI speed.
 - After room temperature reaches the preset temperature, fan speed will be changed to lower speed to obtain optimum room temperature condition for natural healthy cooling.

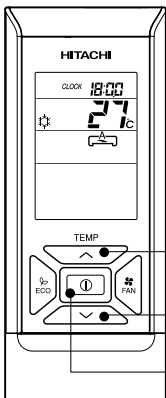

FAN OPERATION

User can use the device simply as an air circulator.

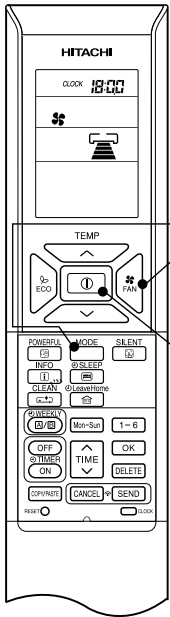





1

Press the MODE selector so that the display indicates  (FAN).

2

Set the desired FAN SPEED with the  (FAN SPEED) button (the display indicates the setting).

 (HIGH) →  (MED) →  (LOW) →  (SILENT)

**START
STOP**

Press the  (START/STOP) button. Fan operation starts with a beep. Press the button again to stop operation.



POWERFUL OPERATION

- By pressing  (POWERFUL) button during AUTO, HEATING, DEHUMIDIFYING, COOLING or FAN operation, the air conditioner performs at the maximum power.
- During POWERFUL operation, cooler or warmer air will be blown out from indoor unit for COOLING or HEATING operation respectively.



■ To start POWERFUL operation

- Press  (POWERFUL) button during operation.

"" is displayed on the LCD.

POWERFUL operation ends in 20 minutes. Then the system automatically operates with the previous settings used before POWERFUL operation.

■ To cancel POWERFUL operation

- Press the  (START/STOP) button. Or
- Press  (POWERFUL) button again.

POWERFUL operation stops.

"" disappears from the LCD.

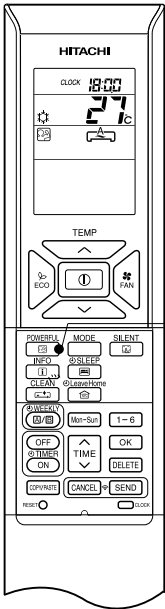

NOTE



- When SLEEP mode, ECO mode, SILENT mode or LEAVE HOME mode is selected, POWERFUL operation is cancelled.
- During POWERFUL operation, capacity of the air conditioner will not increase
 - if the air conditioner is already running at maximum capacity.
 - just before defrost operation (when the air conditioner is running in HEATING operation).
- After auto restart, POWERFUL operation is cancelled and previous operation shall start.
- For multi model connections, POWERFUL operation may not function depending on operation conditions.

SILENT OPERATION

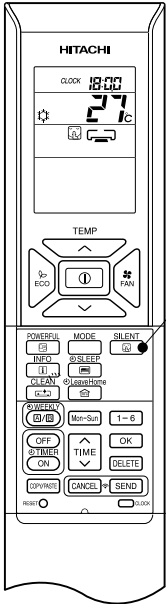



- By pressing  (SILENT) button during AUTO, HEATING, DEHUMIDIFYING, COOLING or FAN operation, the fan speed will change to ultra slow.





■ To start SILENT operation

1. ● Press  (SILENT) button during operation.
“” is displayed on the LCD. Fan speed will be ultra slow.

■ To cancel SILENT operation

- Press  (START/STOP) button. Or
- Press  (SILENT) button again or  (FAN SPEED) button.
Fan speed will return to previous fan speed before SILENT operation starts.
SILENT operation stops.
“” disappears from the LCD.

NOTE

- When POWERFUL operation is selected, SILENT operation is cancelled. Fan speed will return to previous fan speed before SILENT operation.
- After auto restart, SILENT operation is cancelled. Fan speed will return to previous fan speed before SILENT operation.
- During any operation with fan speed  (SILENT), if press  (SILENT) button, fan speed will not change.



ECO OPERATION

ECO operation is an energy saving function by changing set temperature automatically and by limiting the maximum power consumption value.

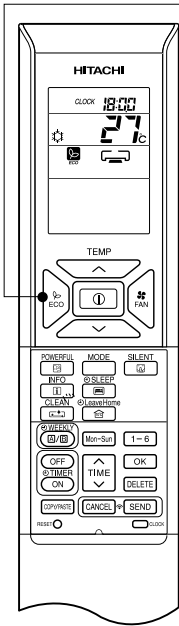

1

- By pressing the  (ECO) button during AUTO, HEATING, DEHUMIDIFYING or COOLING operation, the air conditioner performs the "ECO" operation.

■ To start ECO operation



- Press  (ECO) button during operation.

"" is displayed on the LCD.

A beep sound is emitted from indoor unit.

Energy saving operation will start by changing the set temperature higher or lower automatically and reducing operation power consumption. This function may vary based on the connected outdoor unit.

■ To cancel ECO operation

- Press  (START/STOP) button. Or
- Press  (ECO) button again.

"" disappears from the LCD.

A beep sound is emitted from indoor unit.

NOTE

- ECO function will not be effective when power consumption is low.
- By pressing (POWERFUL) button, ECO operation is cancelled.
- After auto restart, ECO operation is cancelled and previous operation mode shall start.
- For multi model connections, energy saving operation shall start only by changing set temperature higher or lower automatically. However, effectiveness of ECO depends on operation conditions.

10°C LEAVE HOME (LH) OPERATION

Prevent the room temperature from falling too much when no one is at home. The initial setting temperature is 10°C and the temperature range can be set between 10°C and 16°C.

This operation is able to operate by "Continuous operation" or "Day timer operation". Please use "Day timer operation" to set the number of days up to 99 days.

Continuous operation

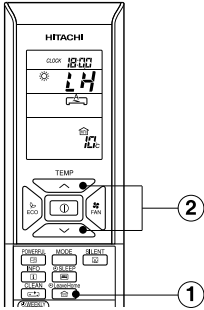

Day timer operation

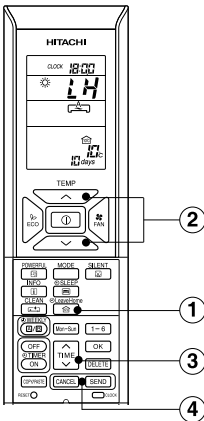

To start LEAVE HOME operation

Option 1. Continuous operation.

- ① Press (LEAVE HOME) button during stop or operation. Room temperature is set at 10°C and heating operation starts.
- ② Set the desired room temperature with the TEMPERATURE buttons. Temperature range can be set between 10°C and 16°C. "☀️", "LH", "A", "Lc", "SET TEMPERATURE" is displayed on the LCD.

Option 2. Day timer operation.

- Press (LEAVE HOME) button during stop or operation. Room temperature is set at 10°C and heating operation starts.
- Set the desired room temperature with the TEMPERATURE buttons. Temperature range can be set between 10°C and 16°C. "☀️", "LH", "A", "Lc", "SET TEMPERATURE" is displayed on the LCD.
- ③ Set number of operation days (1 to 99 days), if needed. Press (TIME) button to select number of days. Number of days blink.
 - * Press "∧ (UP)" or "∨ (DOWN)" to set number of days from 1 day to 99 days.
 - * Number of day is counted when clock indicates 0:00.
 - ④ Press (SEND) button to confirm number of operation days. Display for number of operation days will stop blinking. Press (CANCEL) button to reset number of operation days or to have continuous operation.

To cancel LEAVE HOME operation

- Press (START/STOP) button. Or
- Press (LEAVE HOME) button again. Return to previous operation mode. Or
- Change to other operation mode by pressing (MODE) button.

NOTE

- After reaching the set number of operation days for Leave Home or by pressing the (Leave Home) button again, the unit will operate in previous mode.
- During Leave Home operation, fan speed and horizontal air deflector position cannot be changed.
- By pressing (Leave Home) button, implementation of Weekly Timer or Once Timer is cancelled.
- In case of power supply shut down, after autorestart, all setting for number of days operation will be reset and unit shall be in continuous operation.
- POWERFUL, SILENT and ECO operations are not applicable during Leave Home operation.
- For multi connection
 - FAN/COOLING/DEHUMIDIFYING and Leave Home cannot operate at the same time. The first-run unit has a priority and other units in different mode will be in standby mode.
 - Heating operation can be used with Leave Home.
 - When two or more rooms are set to operate Leave Home, the temperature set by Leave Home may not be reached. It also depends on outdoor temperature.



CLEAN (ONE TOUCH CLEAN) OPERATION

Drying indoor heat exchanger after cooling operation to prevent mildew.

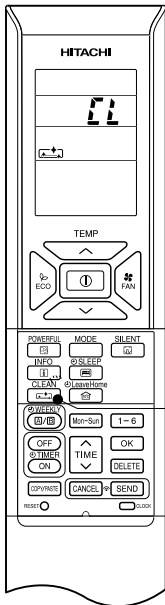



■ To start CLEAN operation

- Press  (CLEAN) button when unit is OFF.
Total time taken for One Touch Clean operation is 60 minutes.
During this operation, HEATING or FAN operation shall operate.
During one touch clean, operation lamp is blinking.

"" , "" is displayed on the LCD.

■ To cancel CLEAN operation

- Press  (START/STOP) button. Or
- Press  (CLEAN) button again.

NOTE

- When CLEAN operation finish, unit will switch OFF automatically.
- If Weekly Timer or Once Timer is set, there is a need to cancel those timer before operating CLEAN function.
- For multi model connections, when pressing  (CLEAN) button, operation is limited to FAN operation.



ONCE TIMER (ON/OFF TIMER) OPERATION

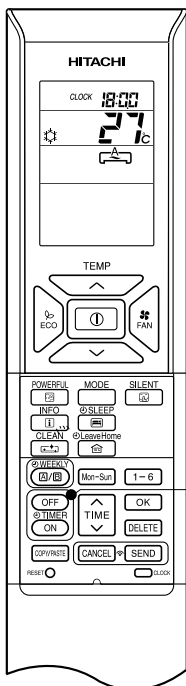

OFF TIMER

The device can be set to turn off at a preset time.

1. Press **OFF/TIMER** (OFF-TIMER) button. and **0:00** blink on the display.
2. Set the "turn-off time" with **TIME** (TIME) button.
3. After setting, direct the remote controller towards the indoor and press **SEND** (SEND) button.
 and "set time" lights up instead of blinking.
A beep sound emitted from indoor unit and the (TIMER) lamp on the indoor unit lights up.

ON TIMER

The device will turn on at a designated time.

1. Press **ON/TIMER** (ON-TIMER) button. and **0:00** blink on the display.
2. Set the "turn-on time" with **TIME** (TIME) button.
3. After setting, direct the remote controller towards the indoor and press **SEND** (SEND) button.
 and "set time" light up instead of blinking.
A beep sound emitted from indoor unit and the (TIMER) lamp on the indoor unit lights up.

ON/OFF TIMER

- The device will turn on (off) and off (on) at the designated time.
- The switching occurs first at the preset time that comes earlier.
- The arrow mark appears on the display to indicate the sequence of switching operations.

1. Press **OFF/TIMER** (OFF-TIMER) button so that and **0:00** blink on the display.
2. Set the "turn-off" time with **TIME** (TIME) button. After setting, direct the remote controller towards the indoor and press **SEND** (SEND) button.
3. Press **ON/TIMER** (ON-TIMER) button so that and set "turn-off" time light up. The and **0:00** blink.
4. Set the "turn-on" time with **TIME** (TIME) button.
5. After setting, direct the remote controller towards the indoor and press **SEND** (SEND) button.
 and set "turn-on" time light up instead of blinking.
A beep sound emitted from indoor unit and the (TIMER) lamp on the indoor unit lights up.

- The timer may be used in three ways: OFF-timer, ON-timer and ON/OFF (OFF/ON)-timer. Set the current time first because it serves as a reference.

■ To cancel Reservation

- Point the signal window of the remote controller towards the indoor unit and press **CANCEL** (CANCEL) button.
 and "ON or OFF set time" goes out with a beep and the (TIMER) lamp on the indoor unit turns off.

NOTE

- User can set only one of the OFF-timer, ON-timer or ON/OFF-timer.
- If WEEKLY TIMER already set, by setting the ONCE TIMER, ONCE TIMER operation is prioritized. When ONCE TIMER operation is complete, WEEKLY TIMER operation will be activated.



ECO SLEEP TIMER OPERATION

The timer can be set up to a duration of 7 hours.

By pressing (SLEEP) button during AUTO, HEATING, DEHUMIDIFYING, COOLING or FAN operation, the unit shifts the room temperature and reduces the fan speed. It results in energy saving.

Set the current time first before operating the ECO SLEEP TIMER operation.

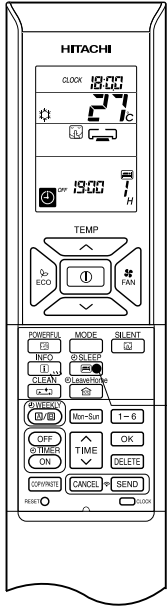

■ To start ECO SLEEP TIMER operation

Press (SLEEP) button during operation.

- “”, “”, “”, “OFF”, off time, “” and number of hour are displayed on the remote controller display.
- During ECO SLEEP TIMER operation, fan speed will be ultra slow.
- A beep sound emitted from indoor unit and the (TIMER) lamp on the indoor unit lights up.

Pressing (SLEEP) button repeatedly, the number of hours will change as below:

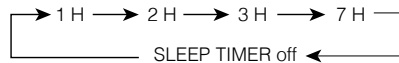

- During ECO SLEEP TIMER operation, air conditioner will continue to operate for the designated number of hours and then turn off.
- When the ECO SLEEP TIMER has been set, the display on the remote controller indicates the turn off time.



Example: If ECO SLEEP TIMER is set for 1 hour at 18:00, the switch off time will be at 19:00.

■ To cancel ECO SLEEP TIMER operation

Press (START/STOP) button.

- Room air conditioner will switch off.

Press (SLEEP) button again until “”, “”, “”, off time, “” and number of hour disappear from the remote controller display.

Press (CANCEL) button.

- A beep sound emitted from indoor unit and the (TIMER) lamp on the indoor unit turns off.
- SLEEP TIMER operation is cancelled.



ECO SLEEP TIMER OPERATION

To set ECO SLEEP TIMER and ON TIMER

The air conditioner will be turned off by ECO SLEEP TIMER and turned on by ON TIMER.





1. Set the ON TIMER.
2. Press  (SLEEP) button and set ECO SLEEP TIMER.



Example:
In this case, air conditioner will turn off in 2 hours (at 1:38) and it will be turned on at 6:00 the next morning.

To cancel ECO SLEEP TIMER and ON TIMER operation

Direct the remote controller towards the indoor unit and press  (CANCEL) button.

- “”, “”, “”, “OFF”, off time, “”, number of hour, “ON” and ON TIMER set time disappear from the remote controller display.
- A beep sound emitted from indoor unit and the (TIMER) lamp on the indoor unit turns off.
- ECO SLEEP TIMER and ON TIMER reservations are cancelled.

30 minutes after setting ECO SLEEP TIMER, outdoor fan speed will be reduced to lower the noise level and to have comfort operation.

1 hour after setting ECO SLEEP TIMER, set temperature will be slightly shifted. Amount of temperature shifted depends on type of air conditioner.

These automatic operation changes contribute to energy saving without losing comfort.

The level of energy consumption depends on outside temperature, room temperature, set temperature or air conditioner type.

Cooling operation [diagram representation for illustrative purpose only]

Heating operation [diagram representation for illustrative purpose only]

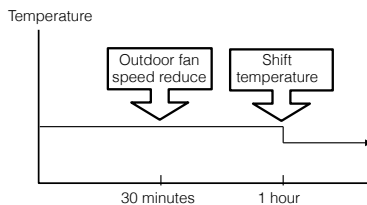
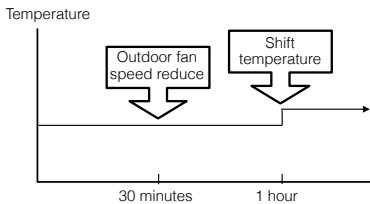

NOTE

- If ECO SLEEP TIMER is set when OFF TIMER or ON/OFF TIMER has been set earlier, the ECO SLEEP TIMER becomes effective instead of the OFF TIMER or ON/OFF TIMER.



WEEKLY TIMER OPERATION

- It is possible to select Mode A or Mode B. For each mode, up to 6 programs can be set per day. In total, a maximum of 42 programs can be set for a week for each mode.
- If calendar and clock are not set, the reservation setting for WEEKLY TIMER cannot be set.
- If calendar and clock are not set correctly, WEEKLY TIMER will not operate correctly.
- Reservation for calendar and clock shall be set first before operating WEEKLY TIMER.

Step 1: Set the reservation schedule to the remote controller. Send the registered reservation to indoor unit and then operate.

Step 2: Select Mode A or Mode B and activate or deactivate WEEKLY TIMER .

Step 3: Copy and cancel the reservation schedule.

Step 1 : Set reservation schedule to the remote controller. Send the registered reservation to indoor unit and then operate.

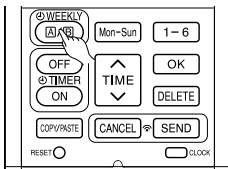

①

How to set a WEEKLY TIMER.

1. Select Mode A or Mode B

Press (WEEKLY) button. WEEKLY lights up. **A** and blink on the display. (Mode A is selected).

②

Press (WEEKLY) button again, **B** and blink on the display. (Mode B is selected).

- If no reservation has been made, ON/OFF, , , appear.
- If reservation has been made, ON/OFF, , , will not appear.

2. Set a program

Press (WEEKLY) button for about 3 seconds. The selection mode can be changed.

, day: Mon, program no. : 1, ON/OFF, setting time and setting temperature blink on the display.

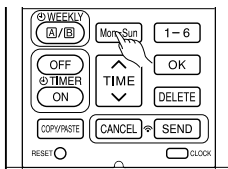

③

3. Select the desired day of the week

Press (DAY) button.

The day changes from Mon → Tue → Wed → Thu → Fri → Sat → Sun → Mon, Tue, Wed, Thu, Fri, Sat, Sun [Full days] → Mon, Tue, Wed, Thu, Fri [weekday] → Sat, Sun [weekend] → Mon → Tue

Select [Full days] for daily reservation.

Select [weekday] for Monday to Friday reservation.

Select [weekend] for Saturday and Sunday reservation.

- After reservation has been set, it is easy to check and edit at the same time.

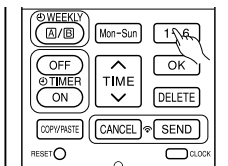

④

4. Press button to select a program number.

The number changes from 1 → 2 → 3 → 4 → 5 → 6 → 1 → 2

- If program number has been set, follow above in order to make changes.

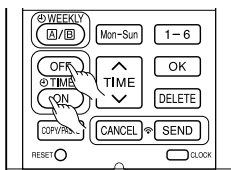

5

5. Press **OFF TIMER/ON** (ON-OFF TIMER) button to select ON TIMER or OFF TIMER reservation.

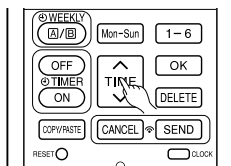

6

6. Press **TIME** (TIME) button to set time reservation.

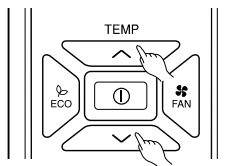

7

7. Press **(TEMP ^ or v)** button to set temperature reservation.

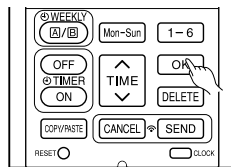

8

8. Press **OK** (OK) button. The reservations are set. Day, program number, ON reservation, setting temperature will light up. **Ⓛ** will be continuously blinks. If reservation is not complete, settings will not be stored in memory.

To continue with the reservation, press **Mon-Sun** **1-6** **TIME** **OFF TIMER/ON** buttons. Follow step 3 to 8 for reservation.

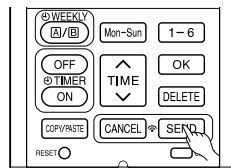

9

9. After all the reservations have been set, press **SEND** (SEND) button while directing the remote controller towards the indoor unit for about 3 seconds. Timer lamp on the indoor unit will blink rapidly. After beep sound emitted from indoor unit, TIMER lamp will light up.

Please ensure that the TIMER lamp lights up.

This indicates that the reservation has been stored in the indoor unit and Timer function has been completed.

The reservation contents will appear on the remote controller display.

- If TIMER lamp on the indoor unit does not light up, press **SEND** (SEND) button while directing the remote controller towards the indoor unit for about 3 seconds.
- **CAUTION !** Do not press **CANCEL** (CANCEL) button during reservation setting because this will result in all reservation contents to be lost.
- The reservation contents will not stored in the indoor unit until **SEND** (SEND) button has been pressed.

NOTE

- Up to 6 programs can be set per day. Setting ON TIMER or OFF TIMER for each program number can be at random. When pressing **SEND** (SEND) button, the set ON TIMER or OFF TIMER for each program number will automatically arranged so that program number 1 shall have the earliest time and program number 6 shall have the latest time. If the setting time is the same, Priority will be given to the latest reservation contents.
- **CAUTION !** If the remote controller is left idle and **SEND** (SEND) button is not pressed within 3 minutes after reservations have been made, all current reservations will be lost.

Step 2: Select Mode A or Mode B and activate or deactivate WEEKLY TIMER.

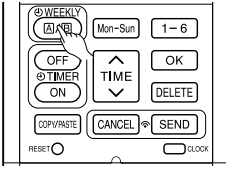

1

2

■ How to select Mode A or Mode B of WEEKLY TIMER setting.

1. Press **WEEKLY (A/B)** button. **A** and **🔌** blink on the display. (Normally Mode A will blink first).
2. Press **WEEKLY (A/B)** button again. **B** and **🔌** blink on the display.
3. Select Mode A or Mode B. Press **SEND (SEND)** button while directing the remote controller towards the indoor unit for about 3 seconds. Timer lamp on the indoor unit will blink rapidly.

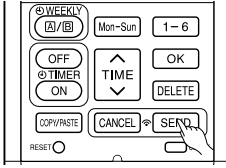

3

After beep sound emitted from indoor unit, TIMER lamp will light up.

Please ensure that the TIMER lamp lights up.

This indicates that Mode A or Mode B selection and active WEEKLY TIMER have been confirmed.

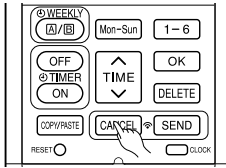

1

■ Setting non-active WEEKLY TIMER .

1. Direct the remote controller towards the indoor unit and press **CANCEL (CANCEL)** button. Beep sound will be emitted from indoor unit and TIMER lamp will be OFF. Reservation indication on remote display will also disappear. This indicates that non-active WEEKLY TIMER has been confirmed.
 - To activate back the setting of WEEKLY TIMER , repeat the steps for "How to select Mode A or Mode B of WEEKLY TIMER setting".

NOTE

- When setting ONCE TIMER, operation of WEEKLY TIMER is interrupted. After ONCE TIMER operation is complete, WEEKLY TIMER operation will be activated.
- When ONCE TIMER is cancelled, operation of WEEKLY TIMER is also cancelled. Need to set WEEKLY TIMER operation for activation.
- After auto restart, WEEKLY TIMER operation is cancelled. Need to set WEEKLY TIMER operation for activation.

Step 3: Copy and cancel the reservation schedule.

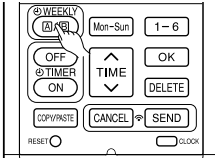

①

■ How to copy and paste.

Editing the reservation schedule is easy by copying data from one day to another day.

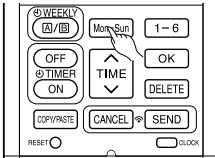

②

1. Press **WEEKLY** (WEEKLY) button to select Mode A or Mode B.

2. Press **WEEKLY** (WEEKLY) button for about 3 seconds to start editing the reservation schedule.

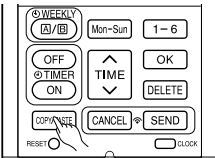

③

3. Press **Mon-Sun** (DAY) button to select a day of the week to copy.

4. Press **COPY/PASTE** (COPY/PASTE) button. Then "PASTE" blinks on the display.
* Press **CANCEL** (CANCEL) button to cancel the COPY mode. Normal setting mode is activated.

5. Press **Mon-Sun** (DAY) button to select a day of the week to paste.

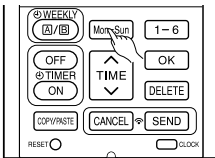

④

6. Press **COPY/PASTE** (COPY/PASTE) button one more time to paste. **⏻** only blinks on the display.

7. To continue copying to other days, press **Mon-Sun** or **1-6** or **TIME** or **OFF/TIMER ON**.

Then start from step 3.

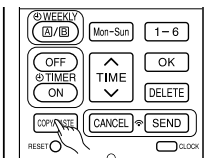

⑤

8. After copy and paste completed, press **SEND** (SEND) button while directing the remote controller towards the indoor unit for about 3 seconds. Timer lamp on the indoor unit will blink rapidly. After beep sound emitted from indoor unit, **TIMER** lamp will light up.

Please ensure that the TIMER lamp lights up.

If **TIMER** lamp does not light up, Press **SEND** (SEND) button again.

- Reservation data will not change if **SEND** (SEND) button is not pressed.

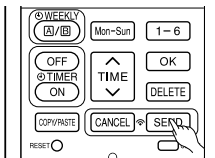

⑥

NOTE

- If there is no reservation data, copying data from one day to another day cannot be done.

Step 3: Copy and cancel the reservation schedule.

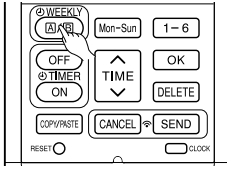

1

■ How to delete WEEKLY TIMER data.

[Delete one program number reservation]

2

1. Press (WEEKLY) button to select Mode A or Mode B.

2. Press (WEEKLY) button for 3 seconds to start editing the reservation schedule.

3. Press (DAY) button to select a day of the week to edit.

4. Press to select program number. Selected program number will blink.

5. Press (DELETE) button. Reservation of selected program number is deleted.

6. After deleting, press (SEND) button while directing the remote controller towards the indoor unit for about 3 seconds. Timer lamp on the indoor unit will blink rapidly.

After beep sound emitted from indoor unit, TIMER lamp will light up.

Please ensure that the TIMER lamp lights up.

● Reservation will not change if (SEND) button is not pressed.

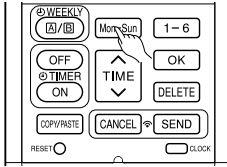

3

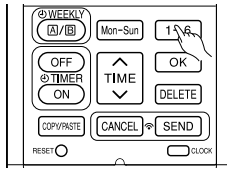

4

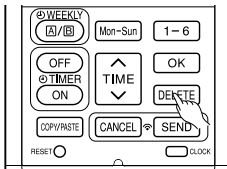

5

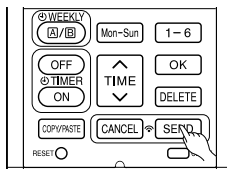

6

Step 3: Copy and cancel the reservation schedule.

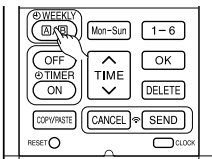

①

[Delete one day reservation]

1. Press **WEEKLY (A/B)** (WEEKLY) button to select Mode A or Mode B.

②

2. Press **WEEKLY (A/B)** (WEEKLY) button for 3 seconds to start editing the reservation schedule.

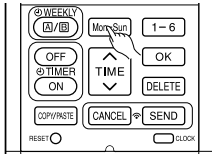

③

3. Press **Mon-Sun** (DAY) button to select a day of the week to edit.

4. Press **DELETE** (DELETE) button for about 10 seconds. Reservations for all program numbers will be deleted.

- If press for a short time, reservation for one program number will be deleted.

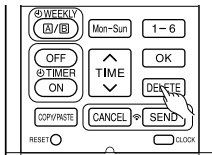

④

5. After deleting, press **SEND** (SEND) button while directing the remote controller towards the indoor unit for about 3 seconds. Timer lamp on the indoor unit will blink rapidly.

After beep sound emitted from indoor unit, TIMER lamp will light up.

Please ensure that the TIMER lamp lights up.

- Reservation will not change if **SEND** (SEND) button is not pressed.

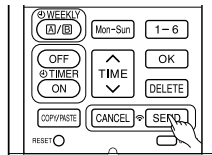

⑤

[Delete Mode A or Mode B]

1. Press **WEEKLY (A/B)** (WEEKLY) button to select Mode A or Mode B.

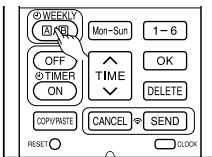

①

2. Direct the remote controller towards the indoor unit and press **DELETE** (DELETE) button for about 10 seconds while Mode A or Mode B display blinks.

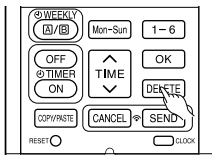

After beep sound emitted from indoor unit, reservations for Mode A or Mode B will disappear.



②

NOTE

- If all reservations in the remote controller were deleted and pressed **SEND** (SEND) button, no signal will be transmitted to indoor unit. TIMER lamp will remain off and no changes will be done to the reservations stored in the indoor unit.

- By pressing  (INFO) button, temperature around remote controller and monthly power consumption will be displayed on the remote controller.
- After changing the batteries, direct the remote controller towards the indoor unit and press  (INFO) button. Current calendar and clock will be transmitted from indoor unit.
- In order to receive information from indoor unit, the distance between remote controller and receiver of indoor units is within 2 meters.

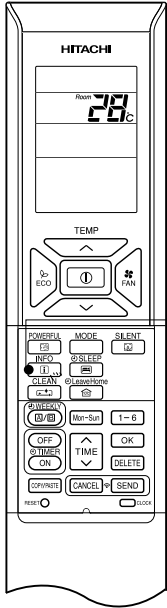

■ To check temperature around remote controller

1

Press  (INFO) button.

Temperature will be displayed for 10 seconds.

■ To check monthly power consumption

Direct the remote controller towards the receiver of indoor unit (within 2 meters in front of indoor unit) and press  (INFO) button. Wait for 2 seconds for signal transmission.

While temperature around remote controller is displayed, press  (INFO) button repeatedly. The display will show as below:

this month power consumption amount for heating → last month power consumption amount for heating → this month power consumption amount for cooling → last month power consumption amount for cooling → temperature around remote controller → this month power consumption amount for heating cyclically.

- If indication is not given, bring remote controller closer to the receiver of the indoor unit.
- Indicated value shall be regarded as a guide only.



■ Current calendar and clock can be retrieved from indoor unit

Direct the remote controller towards the receiver of indoor unit (within 2 meters in front of indoor unit) and press  (INFO) button. Wait for 2 seconds for signal transmission.

Once received the current calendar and clock, check whether they are correct or not by pressing  CLOCK (CLOCK) button.

- If there is no power supply to indoor unit or calendar and clock have not been set, INFO function cannot be used for sending or receiving information.

NOTE

- In case failure occurs to the air conditioner, by pressing  (INFO) button, an error code will be displayed. Direct the remote controller towards the receiver of indoor unit (within 2 meters in front of indoor unit) and press  (INFO) button. Wait for 2 seconds for signal transmission. An error code will be displayed. Call service center and inform the error code.
- Information of "Monthly power consumption" are not available for 6 rooms multi system.
- Info Function to check monthly power consumption. During installation, in case of power failure or breaker ON / OFF, ensure to set the clock and calendar for each indoor unit (unit in standby mode or auto restart), for single or multi connection, by pressing  (START / STOP) button. Failure to do the above, monthly power consumption amount will not be displayed on the remote controller.

OPERATION MODE LOCK

The remote controller can be set to fix the HEATING mode (including FAN), COOLING mode (including FAN) and DEHUMIDIFYING mode (including FAN) operations.

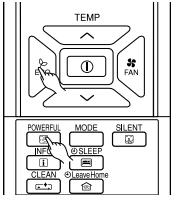

■ Method to lock HEATING mode (including FAN) operation.

Press (ECO) and (POWERFUL) buttons simultaneously for about 5 seconds when the remote controller is OFF.

“☀”, “🌀” and “🔒” will be displayed for about 10 seconds. Later, “☀” and “🔒” will remain.

This indicates that HEATING mode operation is locked.

When pressing (MODE) button, “☀” or “🌀” will be displayed.

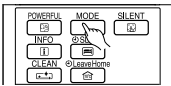

■ Method to unlock HEATING mode (including FAN) operation.

Press (ECO) and (POWERFUL) buttons simultaneously for about 5 seconds when the remote controller is OFF.

All operation mode symbols will appear on the display for about 10 seconds. After that, operation mode symbol before cancellation will be displayed.

This indicates that HEATING mode operation is unlocked.

■ Method to lock COOLING and DEHUMIDIFYING modes (including FAN) operations.

Press (ECO) and (SILENT) buttons simultaneously for about 5 seconds when the remote controller is OFF.

“☀”, “○”, “🌀” and “🔒” will be displayed for about 10 seconds. Later, “☀” and “🔒” will remain.

This indicates that COOLING and DEHUMIDIFYING mode operation is locked.

When pressing (MODE) button, “☀”, “🌀” or “○” will be displayed.

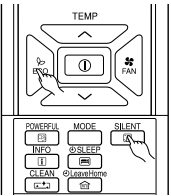

■ Method to unlock COOLING and DEHUMIDIFYING modes (including FAN) operations.

Press (ECO) and (SILENT) buttons simultaneously for about 5 seconds when the remote controller is OFF.

All operation mode symbols will appear on the display for about 10 seconds. After that, operation mode symbol before cancellation will be displayed.

This indicates that COOLING and DEHUMIDIFYING modes operation is unlocked.

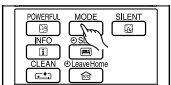

NOTE

- Operation Mode Lock function will not activate if TIMER reservations activate. TIMER reservations shall be deactivated first. Then, Operation Mode Lock function can be activated.
- HEATING, COOLING and DEHUMIDIFYING mode (including FAN) operations can be unlocked by pressing the (RESET) button. However, by pressing the (RESET) button, all the information stored in the remote controller will disappear. You may need to set the necessary information again.

CONSTRUCTION AND DIMENSIONAL DIAGRAM

MODEL RAD-50PPD
RAD-60PPD

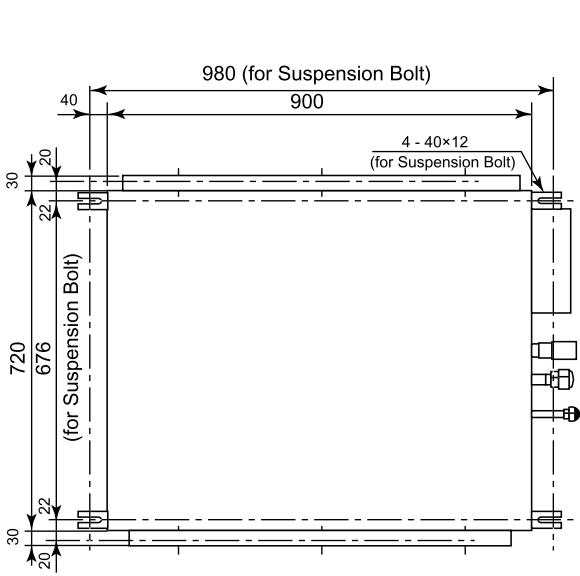

Unit: mm

OPTIONAL
Wired Remote Controller
(SPX-RCDA)

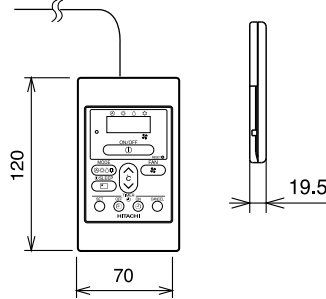

OPTIONAL
Wireless Remote Controller
(SPX-RCKA1)

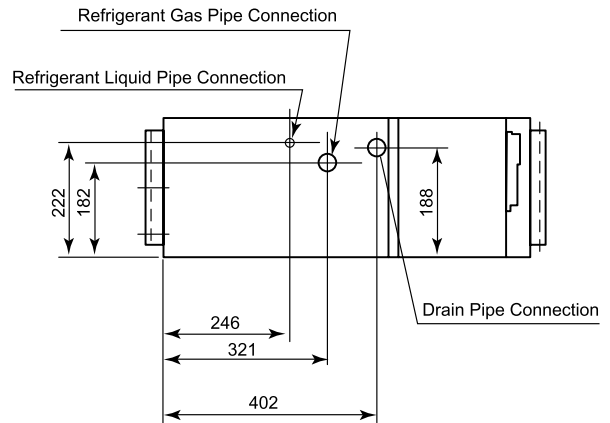
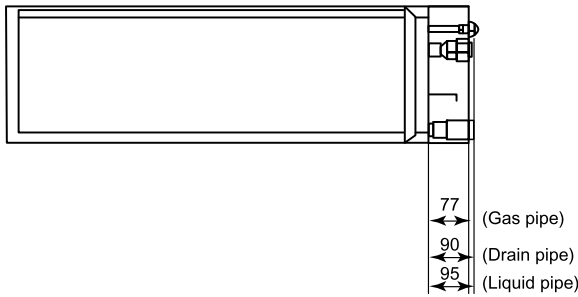
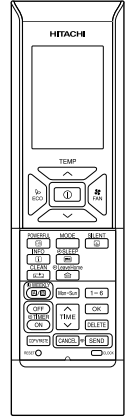

Note:

1. Servicing space of 100mm or more is required on the left and right sides of the indoor unit and also 50mm or more space is required above the unit
2. Insulated pipes should be used for both the narrow and wide dia. pipes.
3. Piping length is within 30m
4. Height different of the piping between the indoor unit and the outdoor unit should be within 10m.
5. Connecting cable 2.5mm dia. x 3 (LN Line), 1.5mm dia. x 4 is used for the connection.

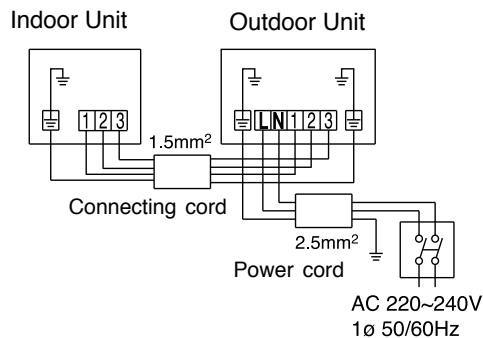

MOUNTING HOLE DIMENSION

MODEL RAD-50PPD
RAD-60PPD

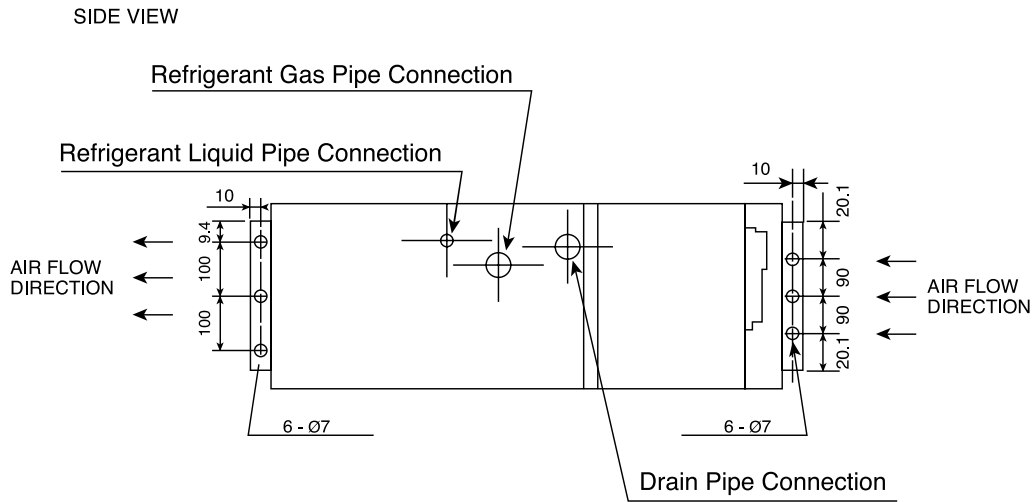

TOP VIEW

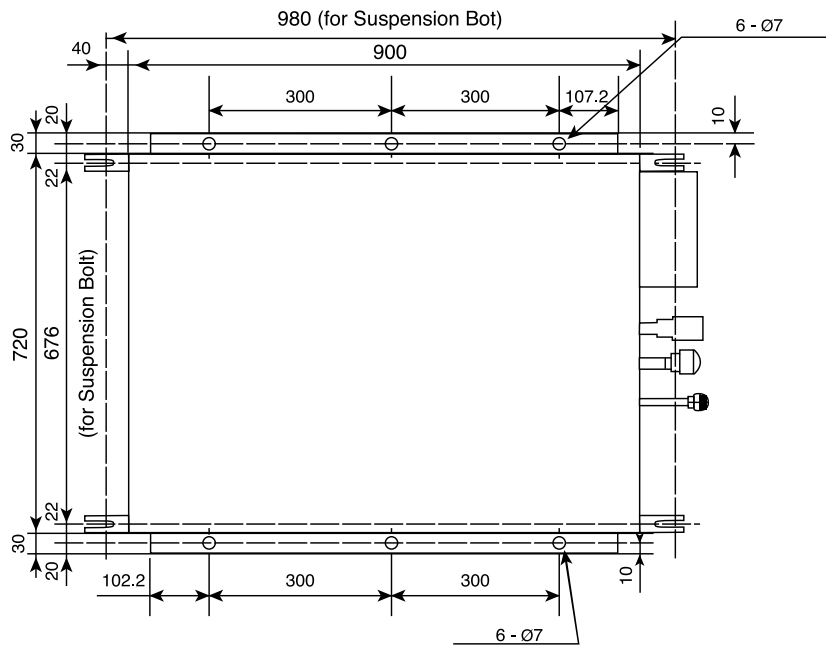

MODEL RAC-50NPD
 RAC-60NPD

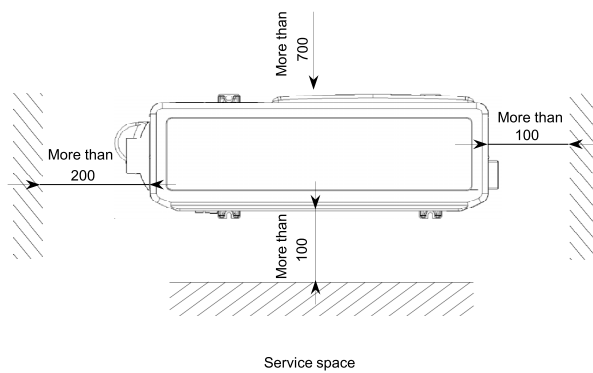
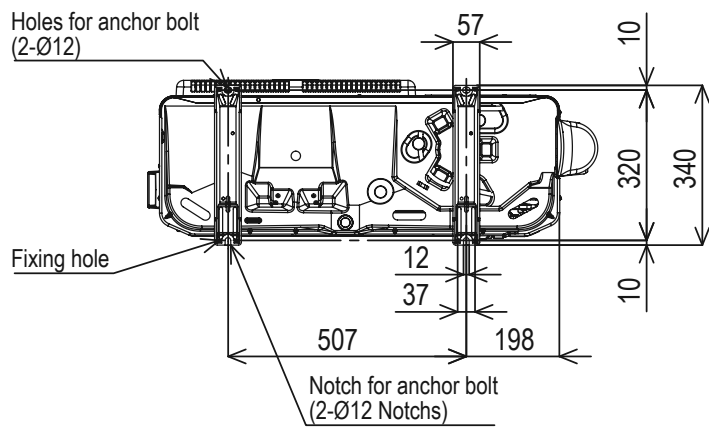
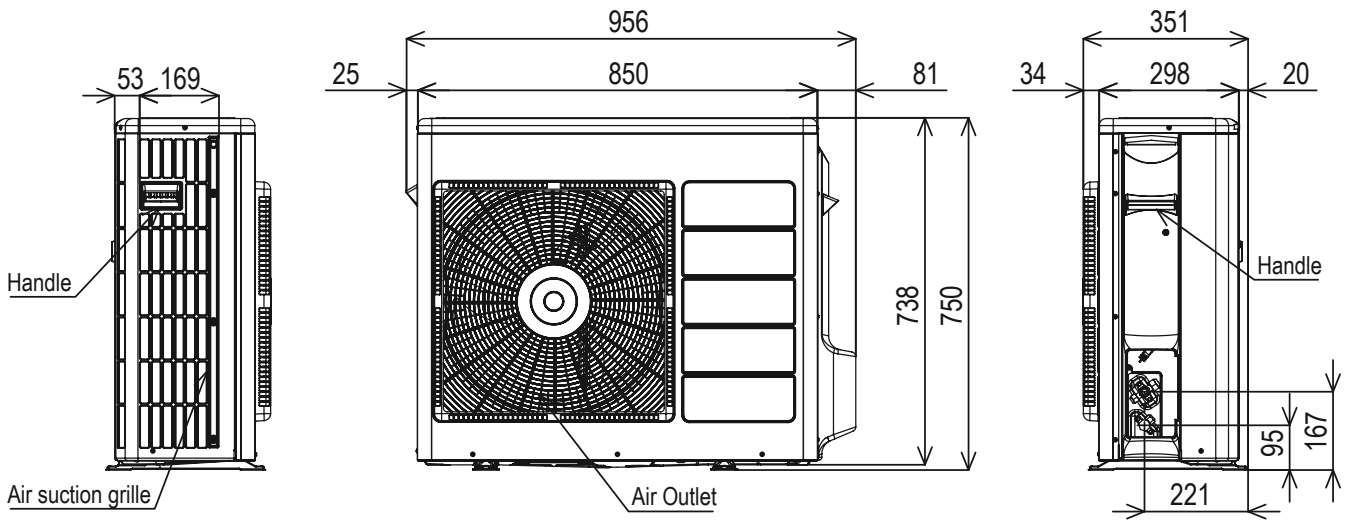

MAIN PARTS COMPONENT

THERMOSTAT (Room Temperature Thermistor)

Thermostat Specifications

MODEL			RAD-50PPD/RAD-60PPD	
THERMOSTAT MODEL			IC	
OPERATION MODE			COOL	HEAT
TEMPERATURE °C (°F)	INDICATION 16	ON	15.6 (60.1)	20.0 (68.0)
		OFF	15.3 (59.5)	20.7 (69.3)
	INDICATION 24	ON	23.6 (74.5)	28.0 (82.4)
		OFF	23.3 (73.9)	28.7 (83.7)
	INDICATION 32	ON	31.6 (88.9)	36.0 (96.8)
		OFF	31.3 (88.3)	36.7 (98.1)

FAN MOTOR

Fan Motor Specifications

MODEL	RAD-50PPD/RAD-60PPD	RAC-50NPD/RAC-60NPD
POWER SOURCE	DC: 310V	DC120~380V
OUTPUT	180W	47W
CONNECTION	<p>(Control circuit built in)</p>	

BLU : BLUE

YEL : YELLOW

BRN : BROWN

WHT : WHITE

GRY : GRAY

ORN : ORANGE

GRN : GREEN

RED : RED

BLK : BLACK

PNK : PINK

VIO : VIOLET

COMPRESSOR MOTOR

Compressor Motor Specifications

MODEL		RAC-50NPD	RAC-60NPD
COMPRESSOR MODEL		JX151XG1	
PHASE		SINGLE	
RATED VOLTAGE		AC 220 ~ 240 V	
RATED FREQUENCY		50 Hz	
POLE NUMBER		4	
CONNECTION			
RESISTANCE VALUE (Ω)	20°C (68°F)	2M = 1.2984	
	75°C (167°F)	2M = 1.7671	

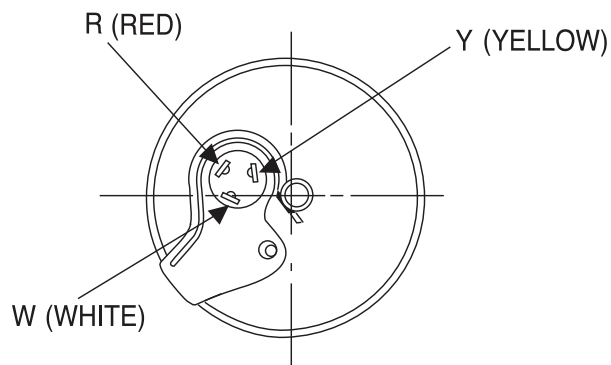

CAUTION

When the Air Conditioner has been operated for a long time with the strainer clogged or crushed or with too little refrigerant, check the color of the refrigerant oil inside the compressor. If the color has been changed conspicuously, replace the compressor.

WIRING DIAGRAM

MODEL RAD-50PPD/RAC-50PPD & RAD-60PPD/RAC-60PPD

- | | | | |
|-------------|--------------|--------------|-------------|
| BLU : BLUE | YEL : YELLOW | BRN : BROWN | WHT : WHITE |
| GRY : GRAY | ORN : ORANGE | GRN : GREEN | RED : RED |
| BLK : BLACK | PNK : PINK | VIO : VIOLET | IVO : IVORY |

INDOOR UNIT

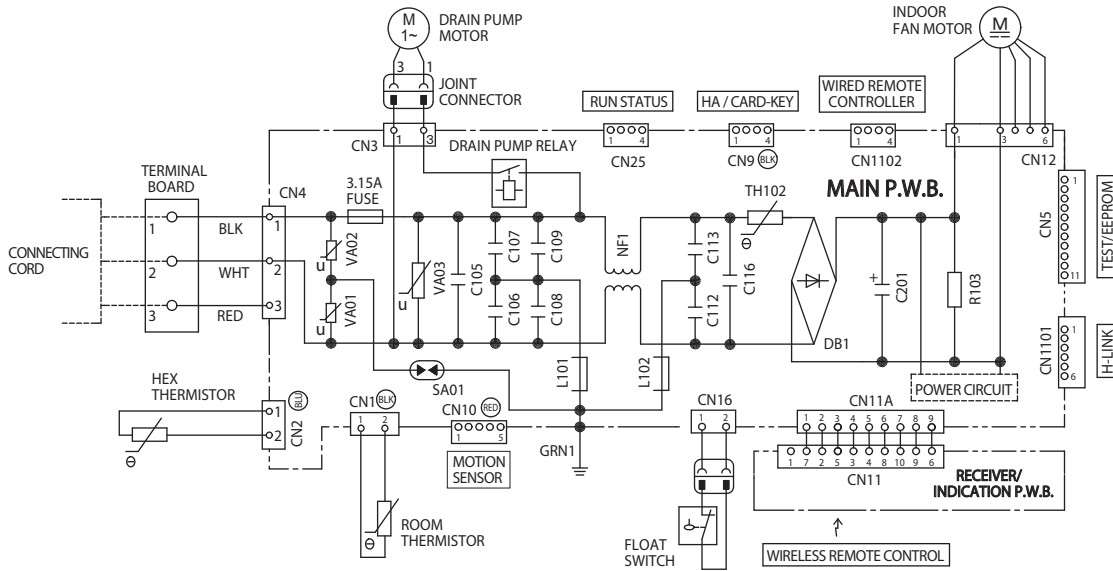

OUTDOOR UNIT

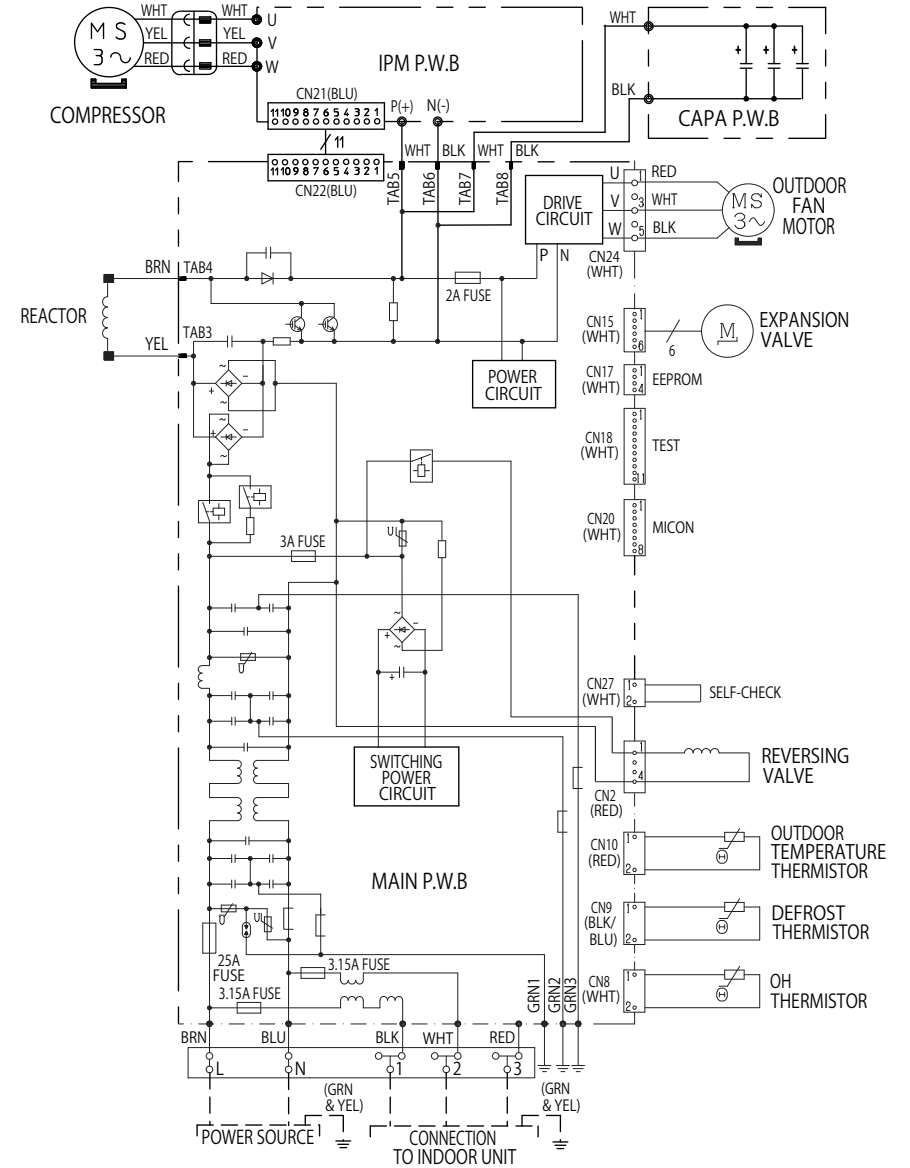

CIRCUIT DIAGRAM

Wired Remote Control

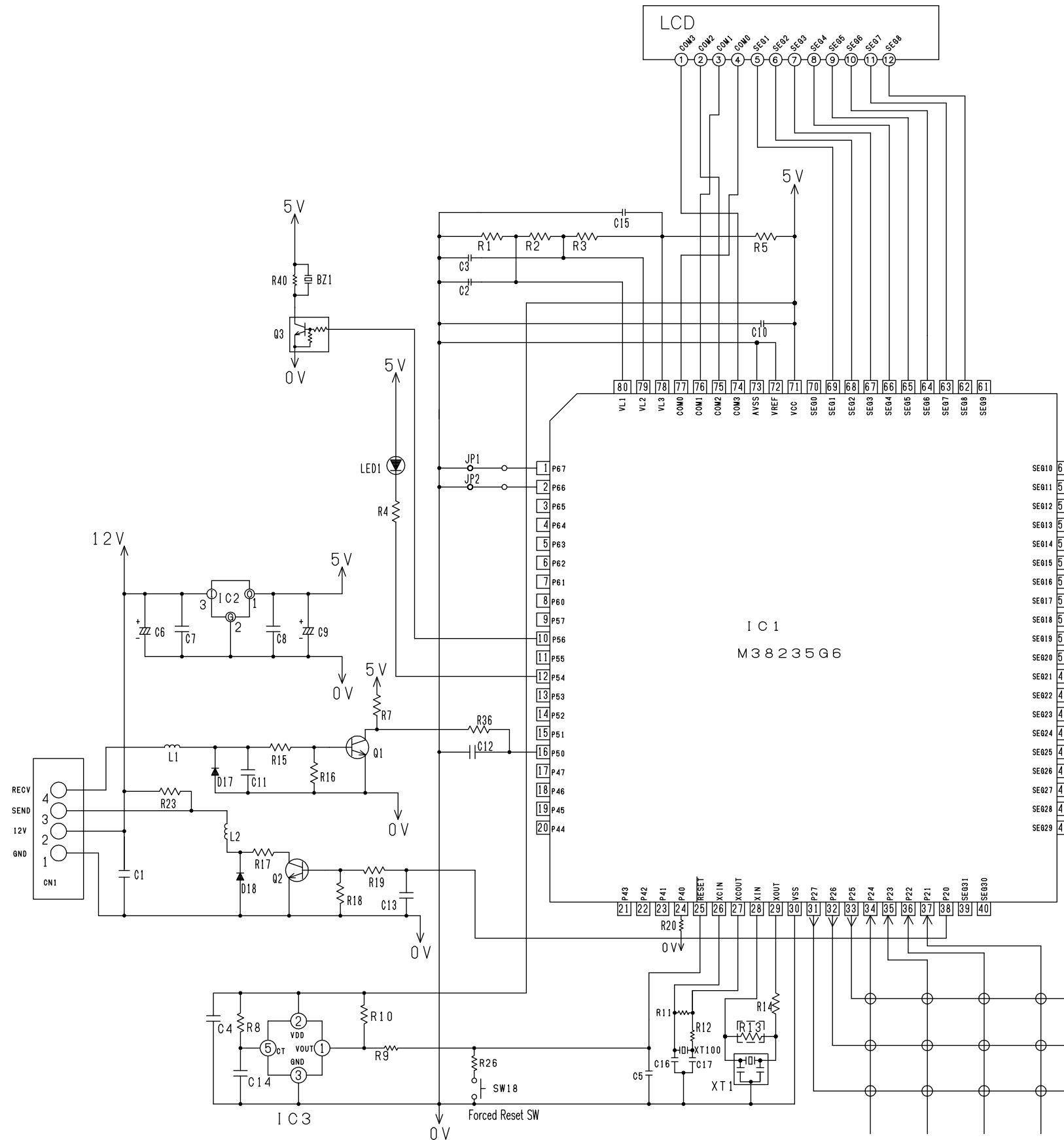

Resistor

symbol	resistance (Ω)	tolerance	power rating (W)	mounting form	surface	remark
R1	220k	5%	1/10	C	A	1608
R2	220k	5%	1/10	C	A	1608
R3	220k	5%	1/10	C	A	1608
R4	1k	5%	1/10	C	A	1608
R5	430k	5%	1/10	C	A	1608
R7	10k	5%	1/10	C	A	1608
R8	No Mount		1/10	C	A	1608
R9	1k	5%	1/10	C	A	1608
R10	300k	5%	1/10	C	A	1608
R11	10M	5%	1/10	C	A	1608
R12	220k	5%	1/10	C	A	1608
R13	No Mount		1/10	C	A	1608
R14	0	5%	1/10	C	A	1608
R15	10k	5%	1/10	C	A	1608
R16	10k	5%	1/10	C	A	1608
R17	0	5%	1/10	C	A	1608
R18	10k	5%	1/10	C	A	1608
R19	10k	5%	1/10	C	A	1608
R20	4.7k	5%	1/10	C	A	1608
R23	10k	5%	1/10	C	A	1608
R26	1k	5%	1/10	C	A	1608
R36	1k	5%	1/10	C	A	1608
R40	No Mount		1/10	C	A	1608
JP1	No Mount		1/10	C	A	1608
JP2	No Mount		1/10	C	A	1608

Capacitor

symbol	capacitance (μF)	rated voltage (V)	type	mounting form	surface	remark	temperature compensating
C1	0.1	25	C	C	A	1608	B
C2	0.1	25	C	C	A	1608	B
C3	0.1	25	C	C	A	1608	B
C4	0.1	25	C	C	A	1608	B
C5	0.1	25	C	C	A	1608	B
C6	10	25	D	C	A		
C7	0.1	25	C	C	A	1608	B
C8	0.1	25	C	C	A	1608	B
C9	10	25	D	C	A		
C10	1	16	C	C	A	1608	B
C11	470p	50	C	C	A	1608	B
C12	470p	50	C	C	A	1608	B
C13	470p	50	C	C	A	1608	B
C14	0.01	50	C	C	A	1608	B
C15	0.1	25	C	C	A	1608	B
C16	18p	50	C	C	A	1608	CH
C17	22p	50	C	C	A	1608	CH

表1 キーマトリックス表
Table1. Key-matrix table

Output \ Input	P21	P22	P23	P24
P25	(自動風向) (Auto lower)	取消 Cancel	風速切換 Wind speed select	予約 Book
P26	切タイマー Off	入タイマー On	温度 \wedge Temperature up	温度 \vee Temperature down
P27	運転/停止 Start/Stop	—	おやすみ Sleep	運転切換 Drive mode select

Diode

symbol	product name	mounting form	surface
D17	1SS355	C	A
D18	1SS355	C	A

LED

symbol	product name	mounting form	surface
LED1	SML-811WT (A)	C	A

IC

symbol	product name	mounting form	surface
IC1	M38235G6-105HP	C	A
IC2	NJM78L05UA	C	A
IC3	S-80942CNMC-69CT2G	C	A

Coil

symbol	product name	mounting form	surface
L1	BLM18AG102SN1D	C	A
L2	BLM18AG102SN1D	C	A

Transistor

symbol	product name	mounting form	surface
Q1	2SC2412K	C	A
Q2	2SC2412K	C	A
Q3	No Mount	C	A

Resonators

symbol	product name	mounting form	surface
XT100	CFS2063276	H	A
XT1	CSTCR4M00G55-R0	C	A

Connector

symbol	product name	mounting form	surface
CN1	S4B-ZR-SM4A-TF	C	A

Buzzer

symbol	product name	mounting form	surface
BZ1	NO MOUNT	C	B

CIRCUIT DIAGRAM

Wireless Remote Controller

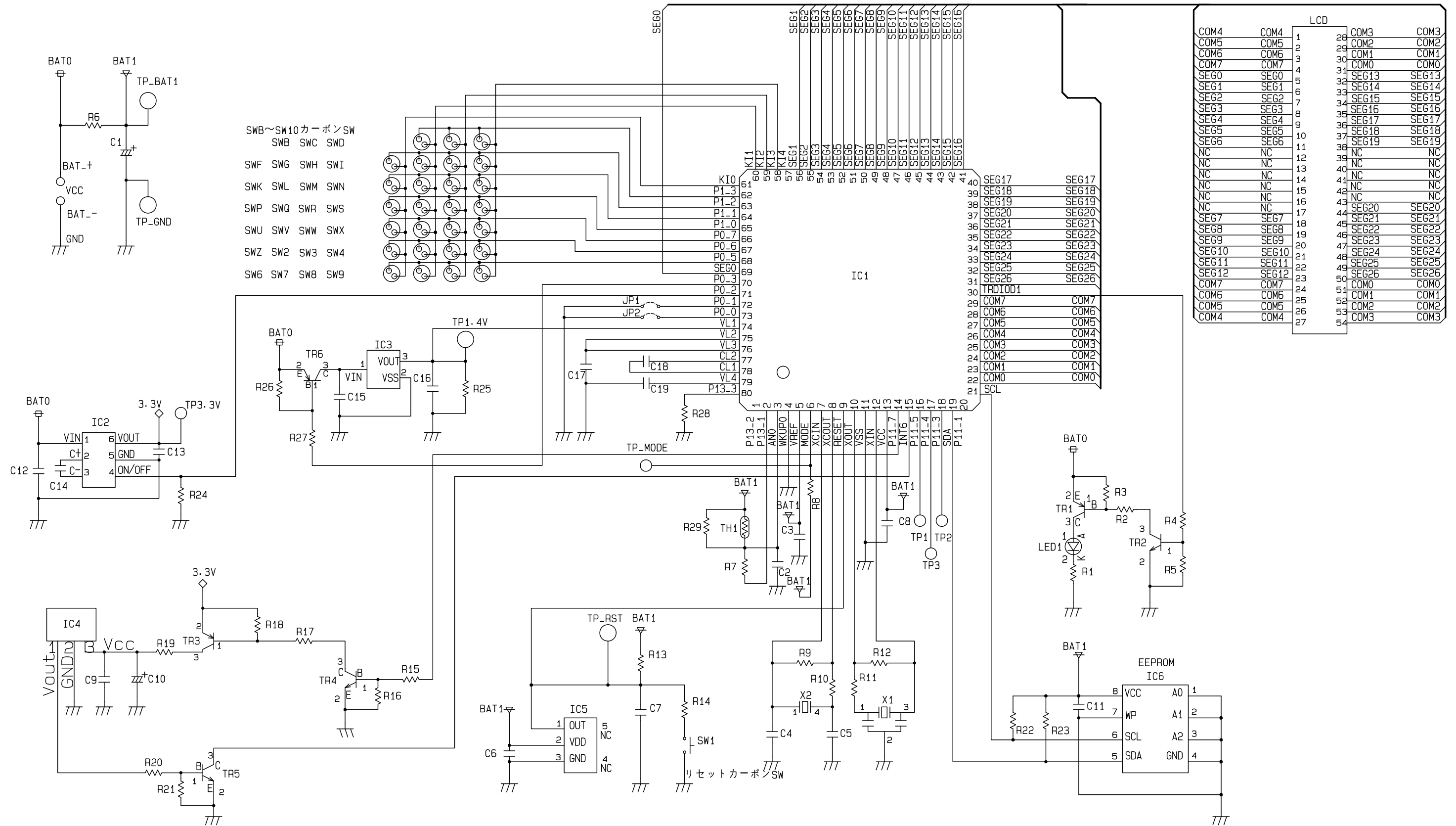

LCD			
COM4	COM4	1	COM3
COM5	COM5	2	COM2
COM6	COM6	3	COM1
COM7	COM7	4	COM0
SEG0	SEG0	5	SEG13
SEG1	SEG1	6	SEG14
SEG2	SEG2	7	SEG15
SEG3	SEG3	8	SEG16
SEG4	SEG4	9	SEG17
SEG5	SEG5	10	SEG18
SEG6	SEG6	11	SEG19
NC	NC	12	NC
NC	NC	13	NC
NC	NC	14	NC
NC	NC	15	NC
NC	NC	16	NC
NC	NC	17	SEG20
SEG7	SEG7	18	SEG21
SEG8	SEG8	19	SEG22
SEG9	SEG9	20	SEG23
SEG10	SEG10	21	SEG24
SEG11	SEG11	22	SEG25
SEG12	SEG12	23	SEG26
COM7	COM7	24	COM0
COM6	COM6	25	COM1
COM5	COM5	26	COM2
COM4	COM4	27	COM3

CIRCUIT DIAGRAM

MODEL : RAC-50NPD/RAC-60NPD
 P.W.B. : MAIN, IPM, CAPA

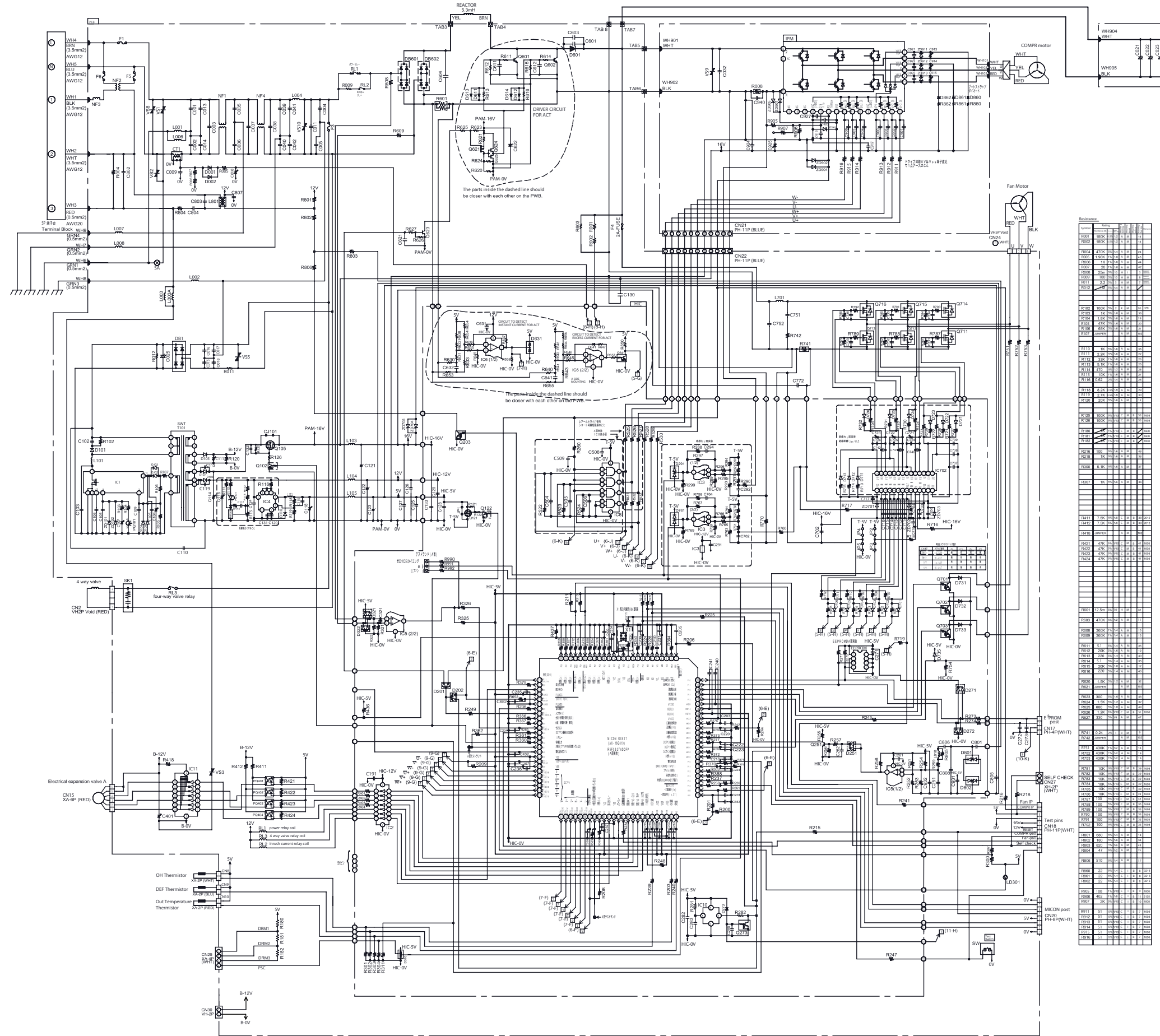

MOUNTING FOOTING
 A: AXIAL INSERTION
 B: RADIAL INSERTION
 F: RADIAL INSERTION (7.5mm pitch)
 H: HAND INSERTION
 C: CNP

MOUNTING BOARD
 M: MAIN PCB (RAC-60-45)
 I: IPM PCB (IPM BOARD)
 C: CAPA PCB (CAPA BOARD)

Ref. No.	Value	Unit	Remarks
R101	10K	Ω	
R102	10K	Ω	
R103	10K	Ω	
R104	10K	Ω	
R105	10K	Ω	
R106	10K	Ω	
R107	10K	Ω	
R108	10K	Ω	
R109	10K	Ω	
R110	10K	Ω	
R111	10K	Ω	
R112	10K	Ω	
R113	10K	Ω	
R114	10K	Ω	
R115	10K	Ω	
R116	10K	Ω	
R117	10K	Ω	
R118	10K	Ω	
R119	10K	Ω	
R120	10K	Ω	
R121	10K	Ω	
R122	10K	Ω	
R123	10K	Ω	
R124	10K	Ω	
R125	10K	Ω	
R126	10K	Ω	
R127	10K	Ω	
R128	10K	Ω	
R129	10K	Ω	
R130	10K	Ω	
R131	10K	Ω	
R132	10K	Ω	
R133	10K	Ω	
R134	10K	Ω	
R135	10K	Ω	
R136	10K	Ω	
R137	10K	Ω	
R138	10K	Ω	
R139	10K	Ω	
R140	10K	Ω	
R141	10K	Ω	
R142	10K	Ω	
R143	10K	Ω	
R144	10K	Ω	
R145	10K	Ω	
R146	10K	Ω	
R147	10K	Ω	
R148	10K	Ω	
R149	10K	Ω	
R150	10K	Ω	
R151	10K	Ω	
R152	10K	Ω	
R153	10K	Ω	
R154	10K	Ω	
R155	10K	Ω	
R156	10K	Ω	
R157	10K	Ω	
R158	10K	Ω	
R159	10K	Ω	
R160	10K	Ω	
R161	10K	Ω	
R162	10K	Ω	
R163	10K	Ω	
R164	10K	Ω	
R165	10K	Ω	
R166	10K	Ω	
R167	10K	Ω	
R168	10K	Ω	
R169	10K	Ω	
R170	10K	Ω	
R171	10K	Ω	
R172	10K	Ω	
R173	10K	Ω	
R174	10K	Ω	
R175	10K	Ω	
R176	10K	Ω	
R177	10K	Ω	
R178	10K	Ω	
R179	10K	Ω	
R180	10K	Ω	
R181	10K	Ω	
R182	10K	Ω	
R183	10K	Ω	
R184	10K	Ω	
R185	10K	Ω	
R186	10K	Ω	
R187	10K	Ω	
R188	10K	Ω	
R189	10K	Ω	
R190	10K	Ω	
R191	10K	Ω	
R192	10K	Ω	
R193	10K	Ω	
R194	10K	Ω	
R195	10K	Ω	
R196	10K	Ω	
R197	10K	Ω	
R198	10K	Ω	
R199	10K	Ω	
R200	10K	Ω	

Ref. No.	Value	Unit	Remarks
C101	1000uF	F	16V
C102	1000uF	F	16V
C103	1000uF	F	16V
C104	1000uF	F	16V
C105	1000uF	F	16V
C106	1000uF	F	16V
C107	1000uF	F	16V
C108	1000uF	F	16V
C109	1000uF	F	16V
C110	1000uF	F	16V
C111	1000uF	F	16V
C112	1000uF	F	16V
C113	1000uF	F	16V
C114	1000uF	F	16V
C115	1000uF	F	16V
C116	1000uF	F	16V
C117	1000uF	F	16V
C118	1000uF	F	16V
C119	1000uF	F	16V
C120	1000uF	F	16V
C121	1000uF	F	16V
C122	1000uF	F	16V
C123	1000uF	F	16V
C124	1000uF	F	16V
C125	1000uF	F	16V
C126	1000uF	F	16V
C127	1000uF	F	16V
C128	1000uF	F	16V
C129	1000uF	F	16V
C130	1000uF	F	16V
C131	1000uF	F	16V
C132	1000uF	F	16V
C133	1000uF	F	16V
C134	1000uF	F	16V
C135	1000uF	F	16V
C136	1000uF	F	16V
C137	1000uF	F	16V
C138	1000uF	F	16V
C139	1000uF	F	16V
C140	1000uF	F	16V

Ref. No.	Value	Unit	Remarks
L101	1mH	mH	
L102	1mH	mH	
L103	1mH	mH	
L104	1mH	mH	
L105	1mH	mH	
L106	1mH	mH	
L107	1mH	mH	
L108	1mH	mH	
L109	1mH	mH	
L110	1mH	mH	
L111	1mH	mH	
L112	1mH	mH	
L113	1mH	mH	
L114	1mH	mH	
L115	1mH	mH	
L116	1mH	mH	
L117	1mH	mH	
L118	1mH	mH	
L119	1mH	mH	
L120	1mH	mH	
L121	1mH	mH	
L122	1mH	mH	
L123	1mH	mH	
L124	1mH	mH	
L125	1mH	mH	
L126	1mH	mH	
L127	1mH	mH	
L128	1mH	mH	
L129	1mH	mH	
L130	1mH	mH	

Ref. No.	Value	Unit	Remarks
IC1	82C55A		82C55A
IC2	74LS164		74LS164
IC3	74LS164		74LS164
IC4	74LS164		74LS164
IC5	74LS164		74LS164
IC6	74LS164		74LS164
IC7	74LS164		74LS164
IC8	74LS164		74LS164
IC9	74LS164		74LS164
IC10	74LS164		74LS164
IC11	74LS164		74LS164
IC12	74LS164		74LS164
IC13	74LS164		74LS164
IC14	74LS164		74LS164
IC15	74LS164		74LS164
IC16	74LS164		74LS164
IC17	74LS164		74LS164
IC18	74LS164		74LS164
IC19	74LS164		74LS164
IC20	74LS164		74LS164
IC21	74LS164		74LS164
IC22	74LS164		74LS164
IC23	74LS164		74LS164
IC24	74LS164		74LS164
IC25	74LS164		74LS164
IC26	74LS164		74LS164
IC27	74LS164		74LS164
IC28	74LS164		74LS164
IC29	74LS164		74LS164
IC30	74LS164		74LS164
IC31	74LS164		74LS164
IC32	74LS164		74LS164
IC33	74LS164		74LS164
IC34	74LS164		74LS164
IC35	74LS164		74LS164
IC36	74LS164		74LS164
IC37	74LS164		74LS164
IC38	74LS164		74LS164
IC39	74LS164		74LS164
IC40	74LS164		74LS164
IC41	74LS164		74LS164
IC42	74LS164		74LS164
IC43	74LS164		74LS164
IC44	74LS164		74LS164
IC45	74LS164		74LS164
IC46	74LS164		74LS164
IC47	74LS164		74LS164
IC48	74LS164		74LS164
IC49	74LS164		74LS164
IC50	74LS164		74LS164

PRINTED WIRING BOARD LOCATION DIAGRAM

■ RAD-50PPD, RAD-60PPD

Main board [component side]

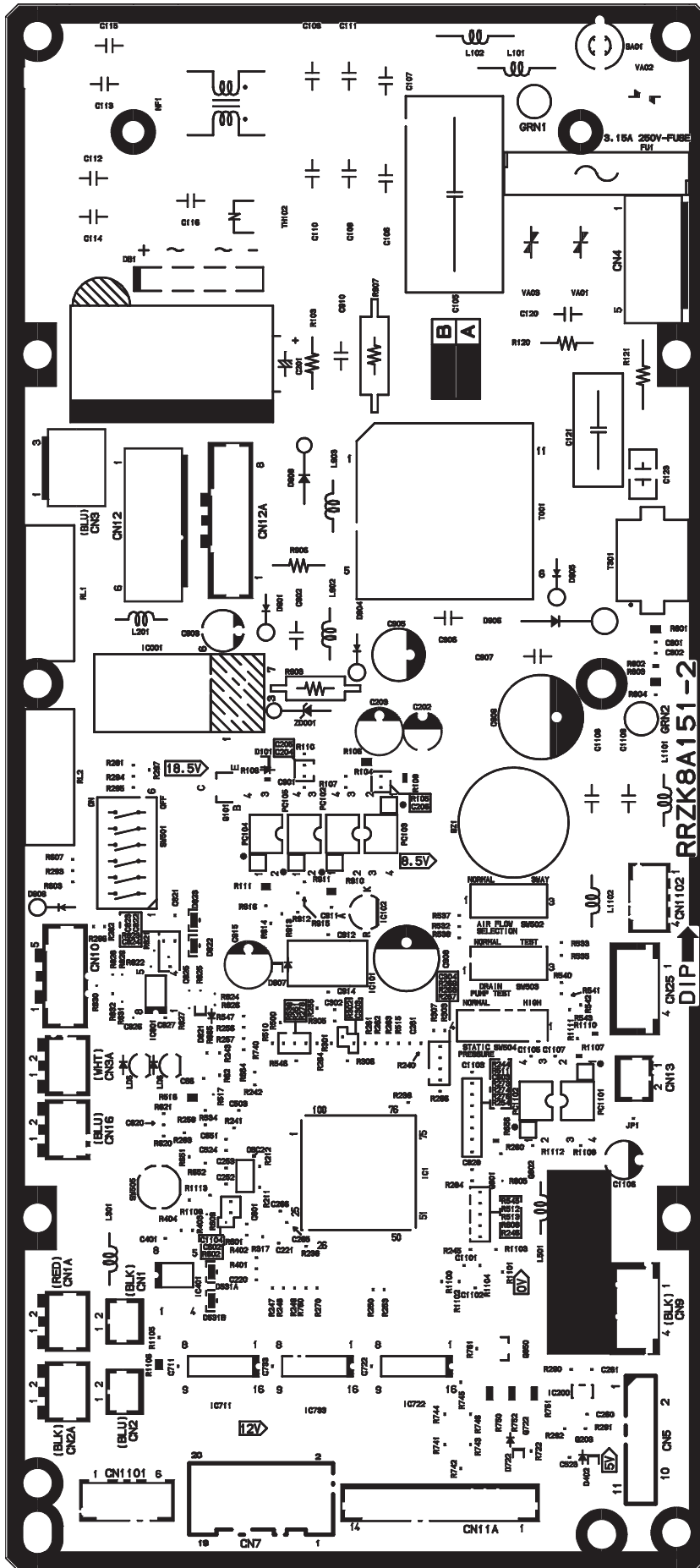

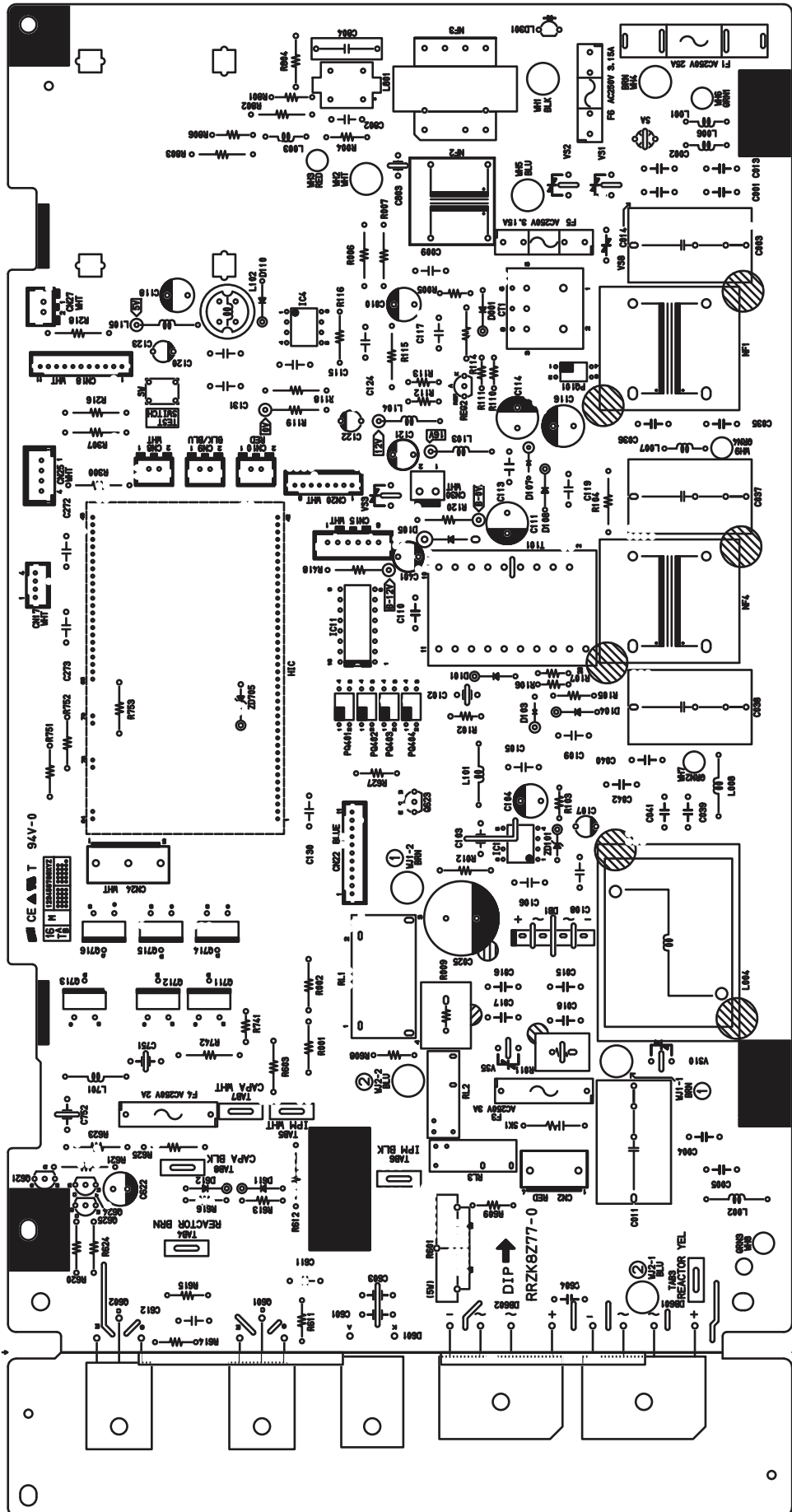

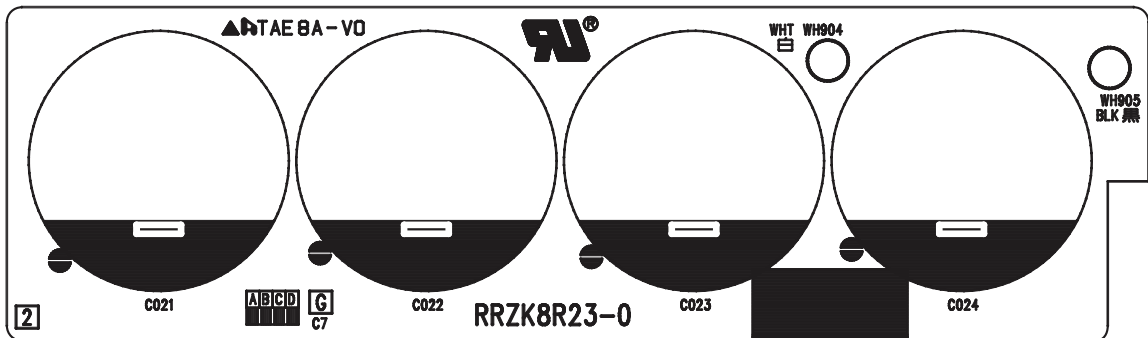
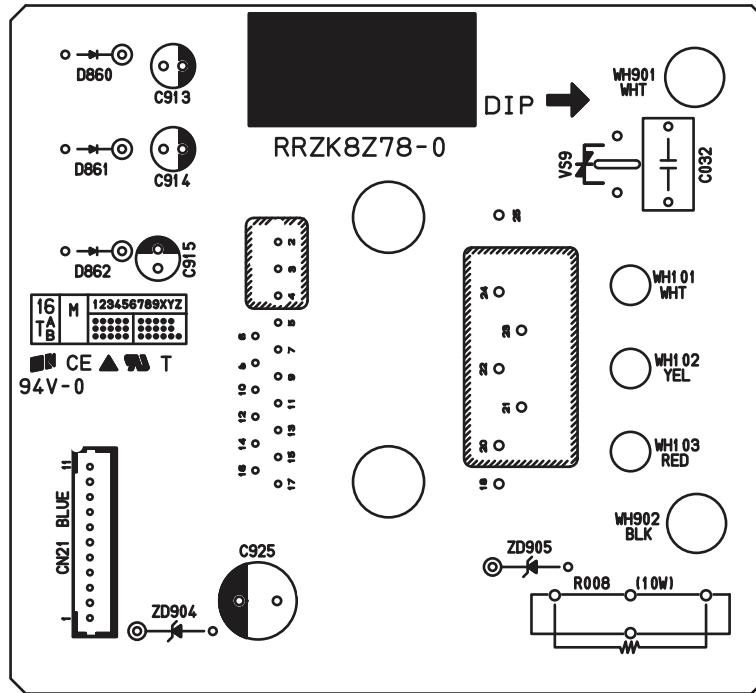

BLOCK DIAGRAM

MODEL RAD-50PPD
RAD-60PPD

RAC-50NPD
RAC-60NPD

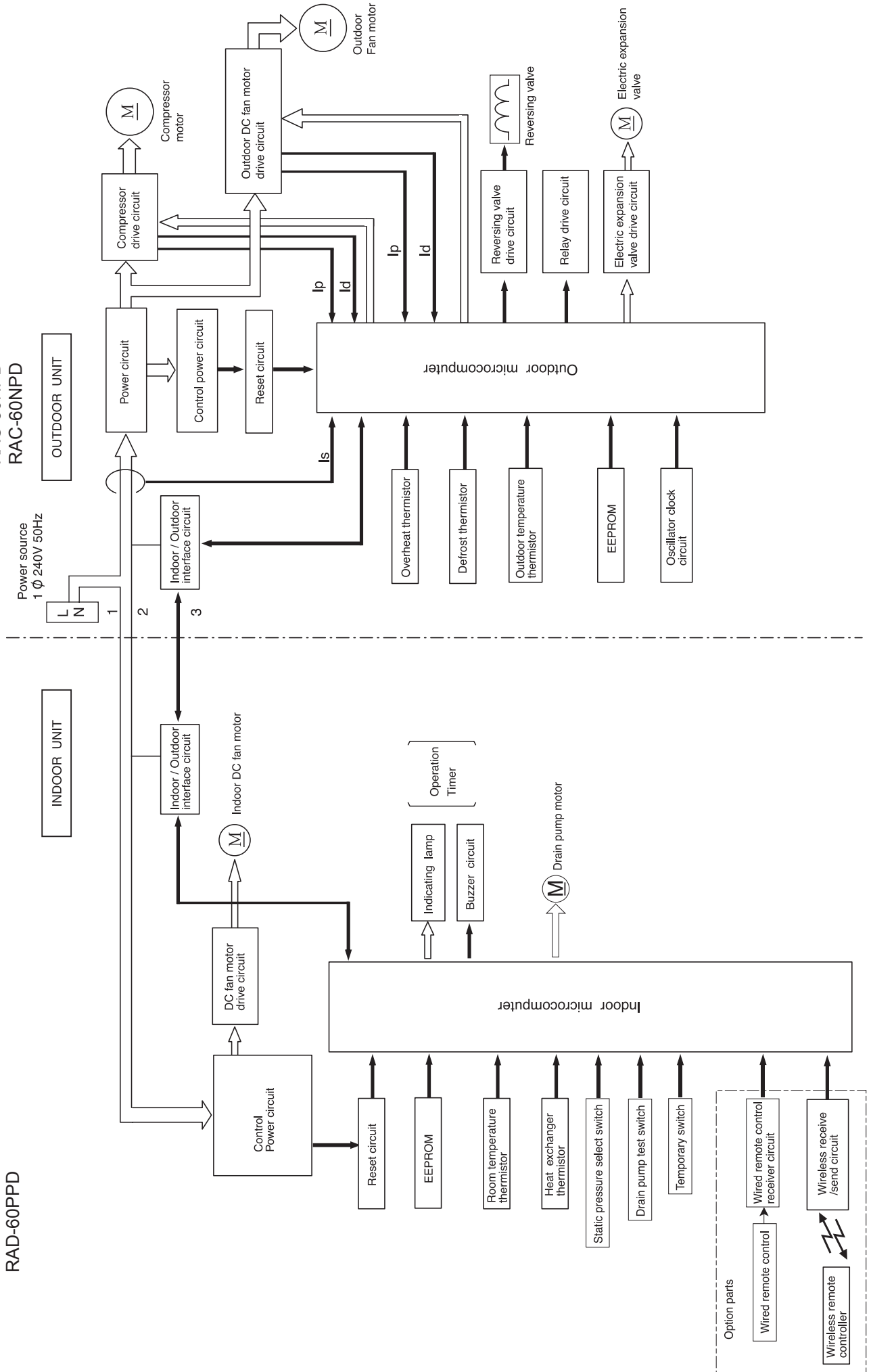

BASIC MODE

MODEL RAD-50PPD / RAD-60PPD

Operation mode		Cooling	Dehumidifying	Heating
Basic operation of start/stop button				
Timer functions	Off-timer			
	On-timer			
Fan speed mode (indoor fan)	Auto	<p>Changes from "Hi" to "Med" or "Lo" depending on room temperature.</p> <ol style="list-style-type: none"> Runs at "Hi" until room temperature reaches to "setting temperature-SFTDSC" after operation is started. Runs at "ultra-Lo" when thermo is off. 		<p>Set to "ultra-Lo", "Silent", "Lo", "Med", "Hi", "ultra-Hi" or "stop" depending on the room temperature, time and heat exchanger temperature. Set to "stop" if the heat exchanger temperature is "DNZKOF" during Thermo OFF.(When reach at "DNZKON", fan speed set to "ultra-Lo" again.)</p> <p>In modes other than left</p> <p>When the compressor is running at maximum speed during hot-dash or when recovered from defrosting.</p>
	Hi	Set to "ultra-Hi" when the compressor runs at cold dash mode speed, and to "Hi" in other modes. Runs at "ultra-Lo" when thermo is off.		Set to "ultra-Lo", "Silent", "Lo", "Med", "Hi", "ultra-Hi" or "stop" depending on the room temperature, time and heat exchanger temperature. Set to "stop" if the heat exchanger temperature is "DNZKOF" during Thermo OFF.(When reach at "DNZKON", fan speed set to "ultra-Lo" again.) Set to "ultra-Hi" when the compressor is running at maximum speed during hot dash or when recovered from defrosting.
	Med	Operates at "Med" regardless of the room temperature. Runs at "ultra-Lo" when thermo is off.		Set to "ultra-Lo", "Silent", "Lo", "Med", "Hi", "ultra-Hi" or "stop" depending on the room temperature, time and heat exchanger temperature. Set to "stop" if the heat exchanger temperature is "DNZKOF" during Thermo OFF.(When reach at "DNZKON", fan speed set to "ultra-Lo" again.)
	Lo	Operates at "Lo" regardless of the room temperature. Runs at "ultra-Lo" when thermo is off.	Set to "Lo" in modes other than when the compressor stops.	Set to "ultra-Lo", "Silent", "Lo", "Med", "Hi", "ultra-Hi" or "stop" depending on the room temperature, time and heat exchanger temperature. Set to "stop" if the heat exchanger temperature is "DNZKOF" during Thermo OFF.(When reach at "DNZKON", fan speed set to "ultra-Lo" again.) The fan speed is controlled by the heat exchanger temperature; the overload control is executed as in the following diagram:
	Silent	Operates at "Silent" regardless of the room temperature. Runs at "ultra-Lo" when thermo is off.	Set to "Silent" in modes other than when the compressor stops.	
Basic operation of temperature controller		See page 51.	See page 55.	See page 59.

Basic Cooling Operation

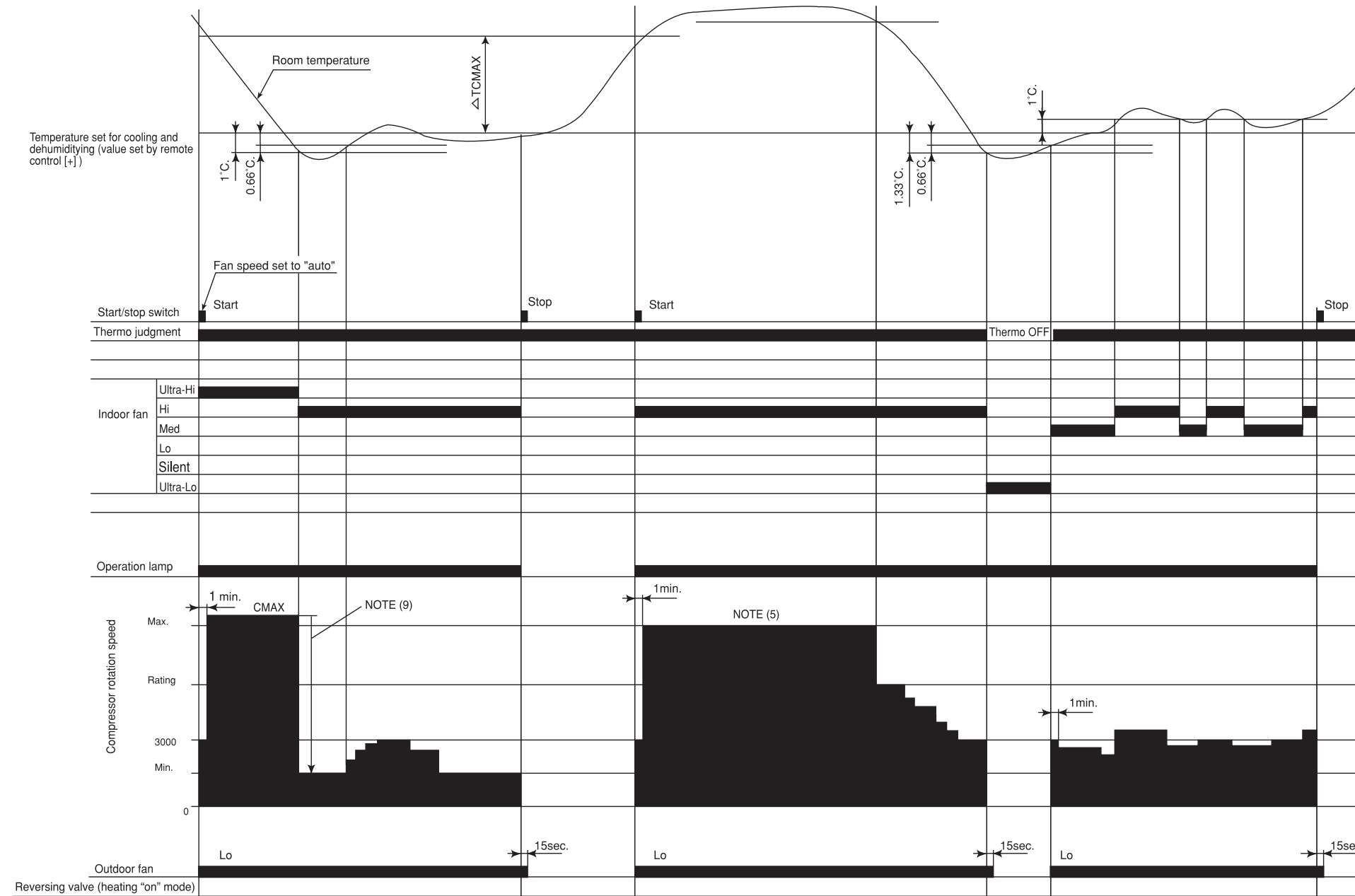

Notes:

- (1) Condition for entering into Cool Dashed mode. When fan set to "Hi" or "Auto and when the compressor speed (P section) due to temperature difference between setting temperature (including the correction shift only) and room temperature is CMAX or higher.
- (2) Cool Dashed will release when i) a maximum 25 minutes is lapsed and ii) room temperature is lower than set temperature -3°C (thermo off) and iii) when room temperature has achieved setting temperature -1°C then maximum Cool Dashed time will be revised to 20 minutes. And iv) indoor fan is set to Lo and Med fan mode and v) change operation mode.
- (3) During Cool Dashed operation, thermo off temperature is set temperature (with shift value) -3°C . After thermo off, operation continue in Fuzzy control mode.
- (4) Compressor minimum "ON" time and "OFF" time is 3 minutes.
- (5) During normal cooling mode, compressor maximum rpm CMAX will maintain for 60 minutes if indoor temperature is lower than CLMXTP. No time constrain if indoor temperature is higher than CLMXTP.
- (6) When fan is set to "Hi", compressor rpm will be limited to CSTD.
- (7) When fan is set to "Med", compressor rpm will be limited to CJKMAX.
- (8) When fan is set to "Lo", compressor rpm will be limited to CBEMAX.
- (9) During Cool Dashed, when room temperature reaches set temperature -1°C compressor rpm is actual rpm x DWNRATEC.

Cooling Sleep Operation

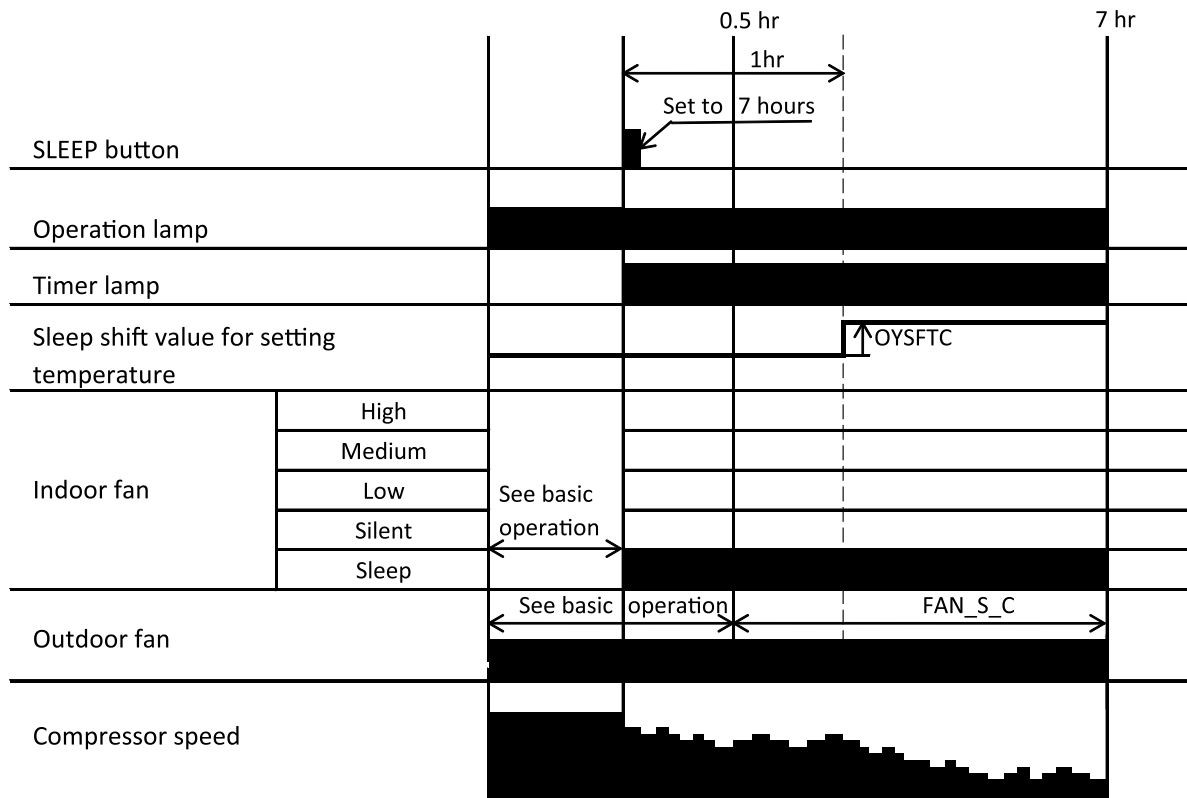

Notes :

- (1) The sleep operation starts when the "SLEEP" button is pressed.
- (2) When the sleep operation is set, the maximum compressor speed is limited to CSZMAX, and the indoor fan set is "sleep"(FCSOY_P).
- (3) The indoor fan speed does not change even when the fan speed mode is changed.
- (4) If sleep operation is canceled by the cancel button or sleep button, all data is cleared.
- (5) 1 hour after the sleep operation is set, the sleep shift value(OYSFTC) is added.

Cooling Defrost

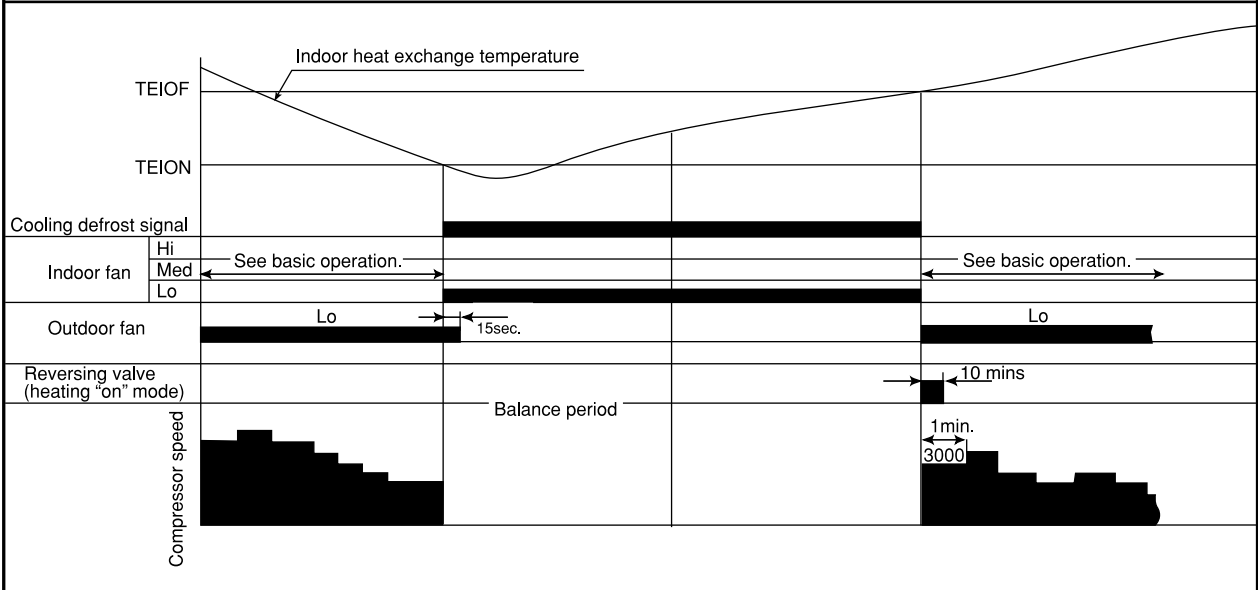

Dehumidifying

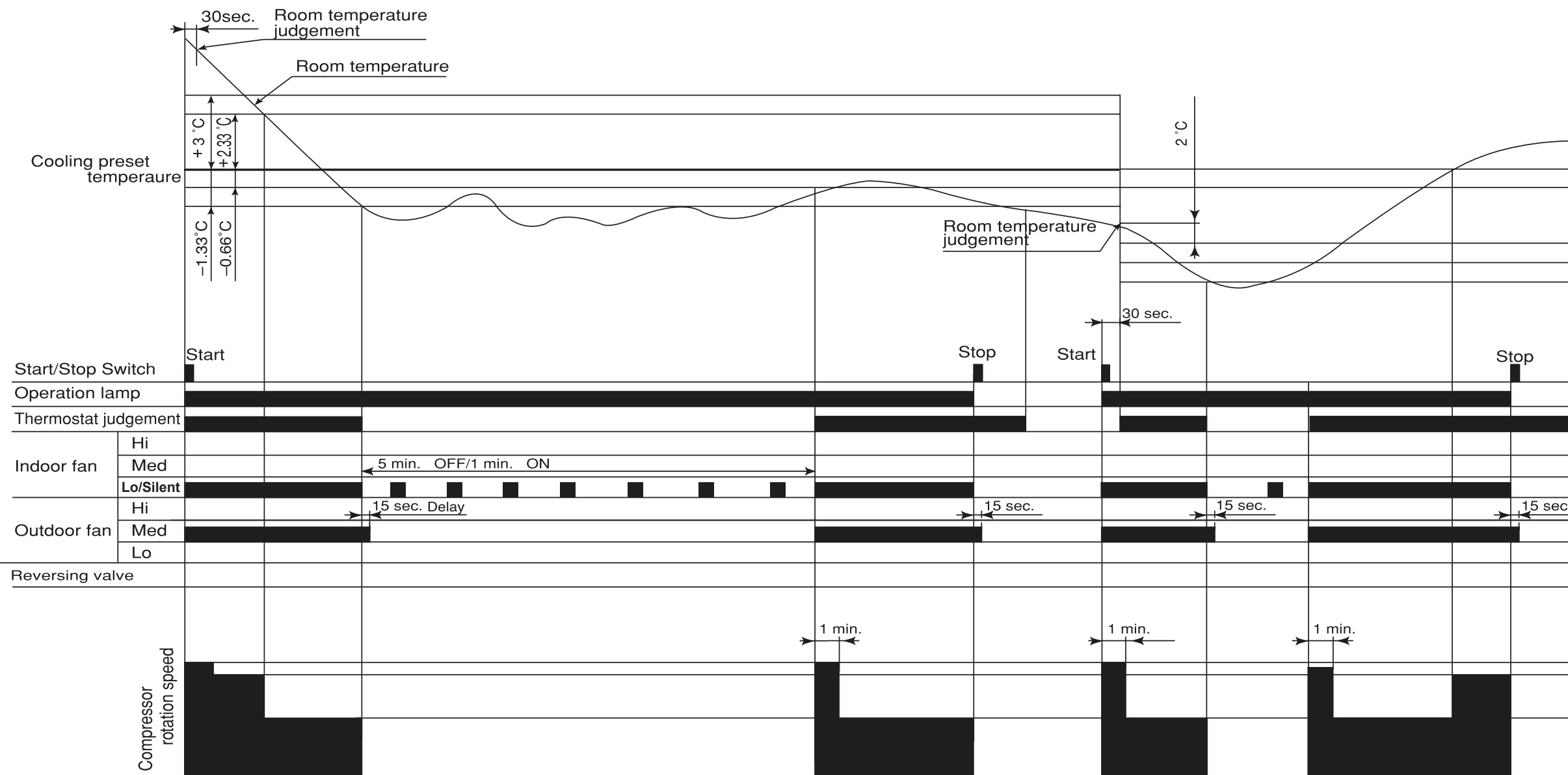

Notes:

- (1) If the room temperature is (cooling preset temperature) - (1.33°C) or less after 30 seconds from starting the operation, the operation is done assuming as the preset temperature = (room temperature at the time) - (2°C).
- (2) The indoor fan is operated in the "Lo" or "Silent" mode. During thermo OFF, indoor fan will be OFF 5 minutes and ON for 1 minute
- (3) When the operation is started by the thermostat turning ON, the start of the indoor fan is delayed 32 seconds after the start of compressor operation.
- (4) The compressor is operated forcedly for 3 minutes after operation is started.
- (5) The minimum ON time and OFF time of the compressor are 3 minutes.

Basic Heating Operation

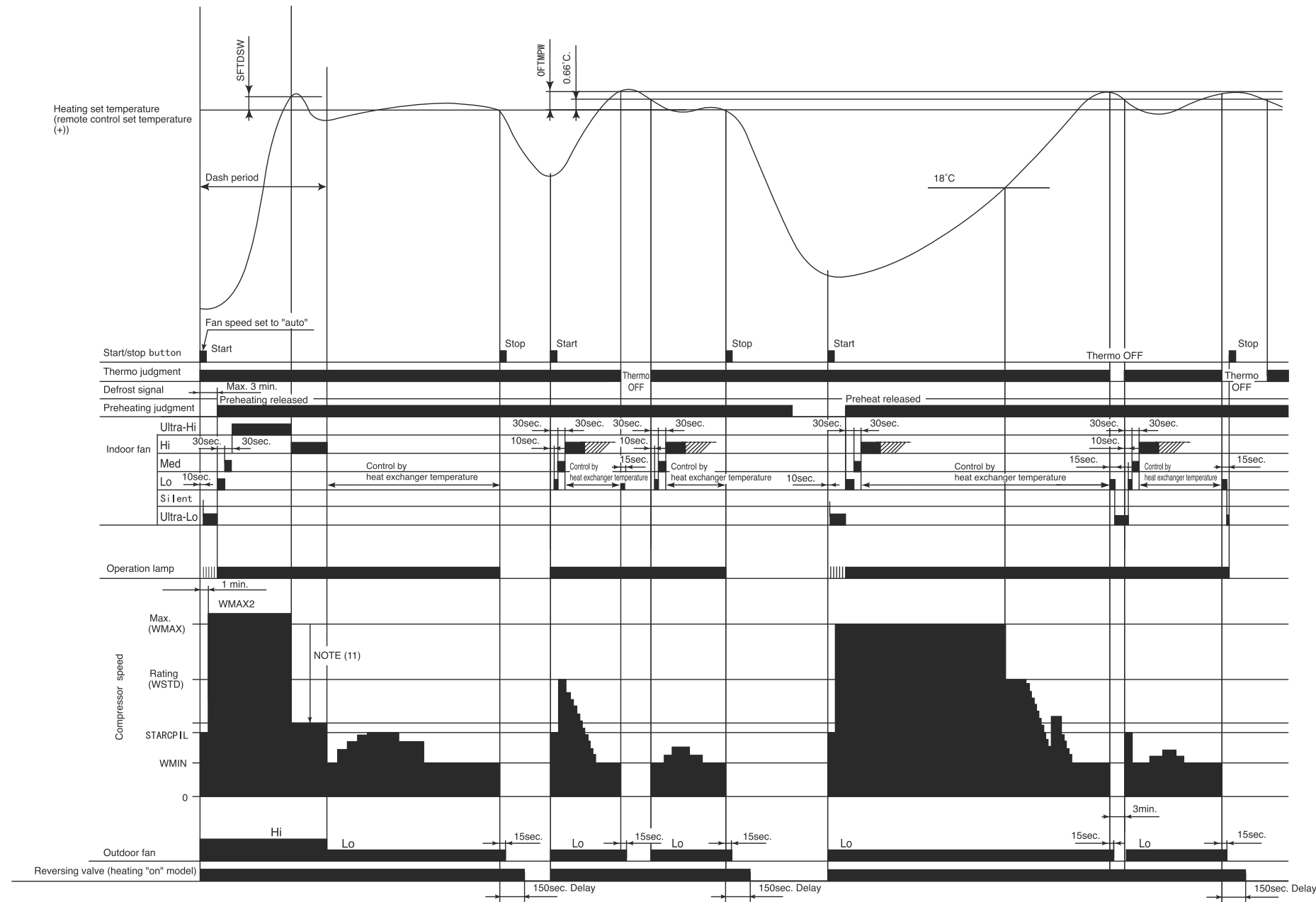

Notes:

- (1) Condition for entering into hot dashed mode. When fan set to "Hi" or "Auto" and i) room temperature is 18 or less, and ii) outdoor temperature is 10 or less, and iii) compressor speed (P section) due to temperature difference between setting temperature(including shift value only) and room temperature is WMAX or more.
- (2) The maximum compressor speed period during hot dash is finished when i) room temperature has reached the setting temperature + SFTDSW. ii) thermo off.
- (3) During hot dashed operation, thermo off temperature is setting temperature (with shift value) +3 . After thermo off, operation continue inn Fuzzy control mode.
- (4) Minimum "ON" time and minimum "OFF" time of compressor operation is 3 minutes.
- (5) During normal heating mode, compressor maximum rpm WMAX will maintain for 120 minutes. No time limit constrain if room temperature is 18 or less and outdoor temperature is 2 or less.
- (6) During preheating or defrosting or auto fresh defrosting mode, indoor unit operation lamp will blink at interval of 2 seconds "ON" and 1 second "OFF".
- (7) When heating mode starts, it will enter into preheating mode if indoor heat exchanger temperature is less than YNEOF + 0.33 .
- (8) When fan is set to "Med" or "Lo" or "Silent", compressor rpm will be limited to "WJKMAX" or "WBEMAX" or "WSZMAX".
- (9) During "Ultra-Lo" mode, heat exchanger temp 18 or less, indoor fan will stop. If hex temperature is 18 + 0.33 or more, fan will continue in "Ultra-Lo" mode. However, "Ultra-Lo" mode during preheating or preheating after defrosting does not stop if room temperature is 18 or less.
- (10) During hot dashed or outdoor temperature is -5 or less, compressor rpm is WMAX2.
- (11) During hot dashed, when room temperature reaches setting temperature + SFTDSW compressor rpm is actual rpm x DWNRATEW.

Reversing valve defrosting

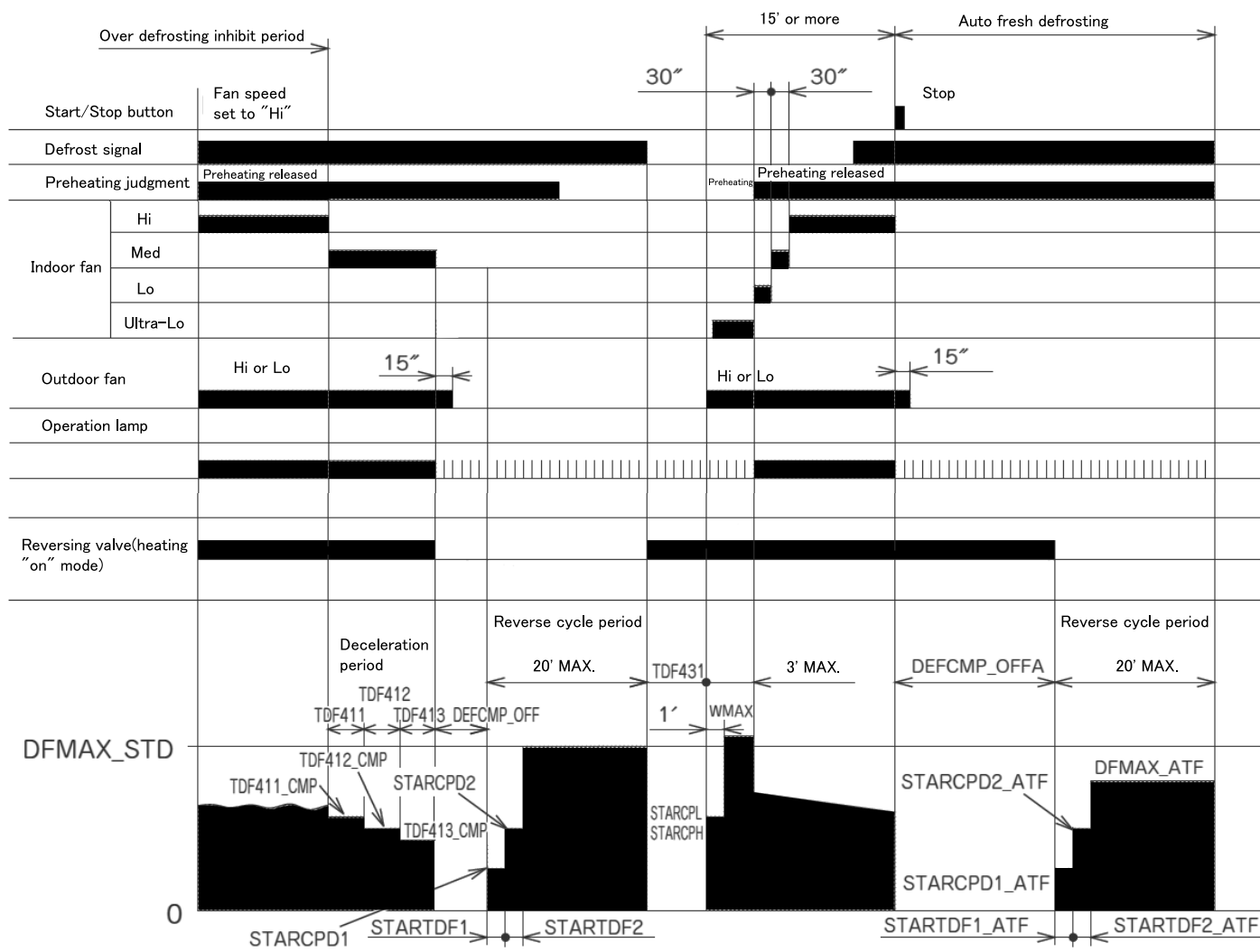

Notes:

- (1) The defrosting inhibit period is set as shown in the diagram below. When defrosting has finished once, the inhibit period is newly set, based on the outdoor temperature when the compressor was started. During this period, the defrost signal is not accepted.
- (2) If the difference between the room and outdoor temperature is large when defrosting is finished, the maximum compressor speed (WMAX) or (WMAX2) can be continued for 120 minutes maximum.
- (3) The defrosting period is 20 minutes maximum.
- (4) When operation is stopped during defrosting, it is switched to auto refresh defrosting.
- (5) Auto refresh defrosting cannot be engaged within 15 minutes after operation is started or defrosting is finished.

Setting Defrosting Inhibit Period

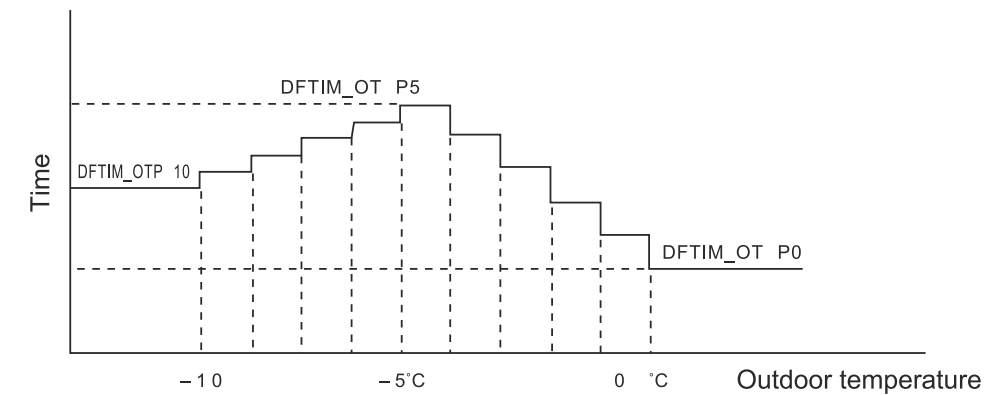

Notes:

- (1) The first inhibit time after operation start is set to DFTIM_FST.
- (2) From the second time onwards, the inhibit time is set according to the time required for defrosting.
Reverse cycle operation time \geq [DEFCOL] : DEFTIM_COL is set.
Reverse cycle operation time $<$ [DEFCOL] : The time corresponding to outdoor temperature is set.

Heating Powerful Operation

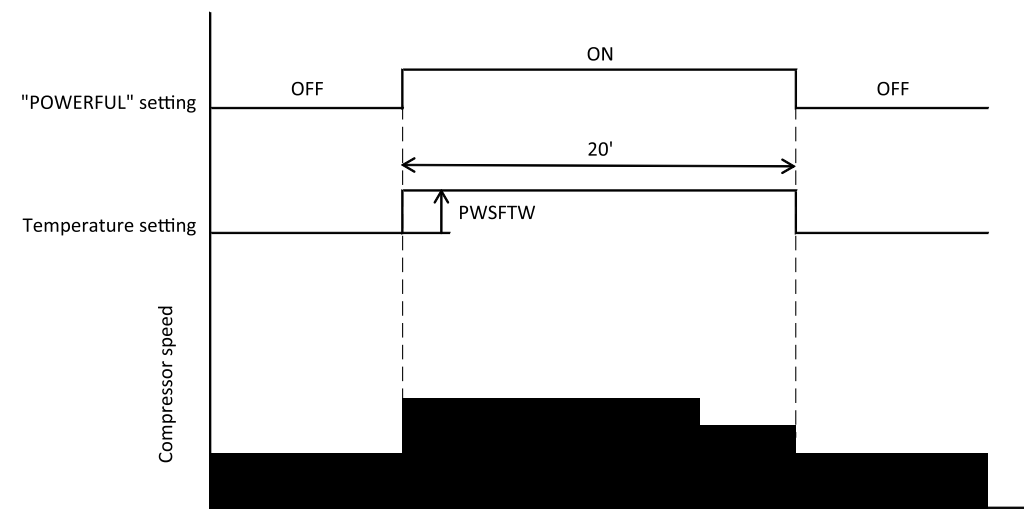

Notes :

- (1) Pressing the "POWERFUL" button will increase the temperature setting by PWSFTW.
- (2) The powerful operation is for 20 minutes after setting.
- (3) Operation is continued forcibly thermo-ON for 20 minutes after the powerful operation is finished.
- (4) Defrost is inhibited for 20 minutes after the start of the powerful operation.
- (5) Pressing the "START/STOP" button and "POWERFUL" button during powerful operation will cancel the powerful operation.
- (6) If the sleep timer is set during powerful operation, the powerful operation will be canceled.
- (7) When the powerful operation is set, the fan speed will be set to "HIGH" and the compressor's maximum speed will be set to WMAX2 during powerful operation. The compressor's lower limit speed is WKYMIN_PW.
- (8) After the powerful operation is ended, the system automatically operates with the previous settings used before the powerful operation.

Leave Home

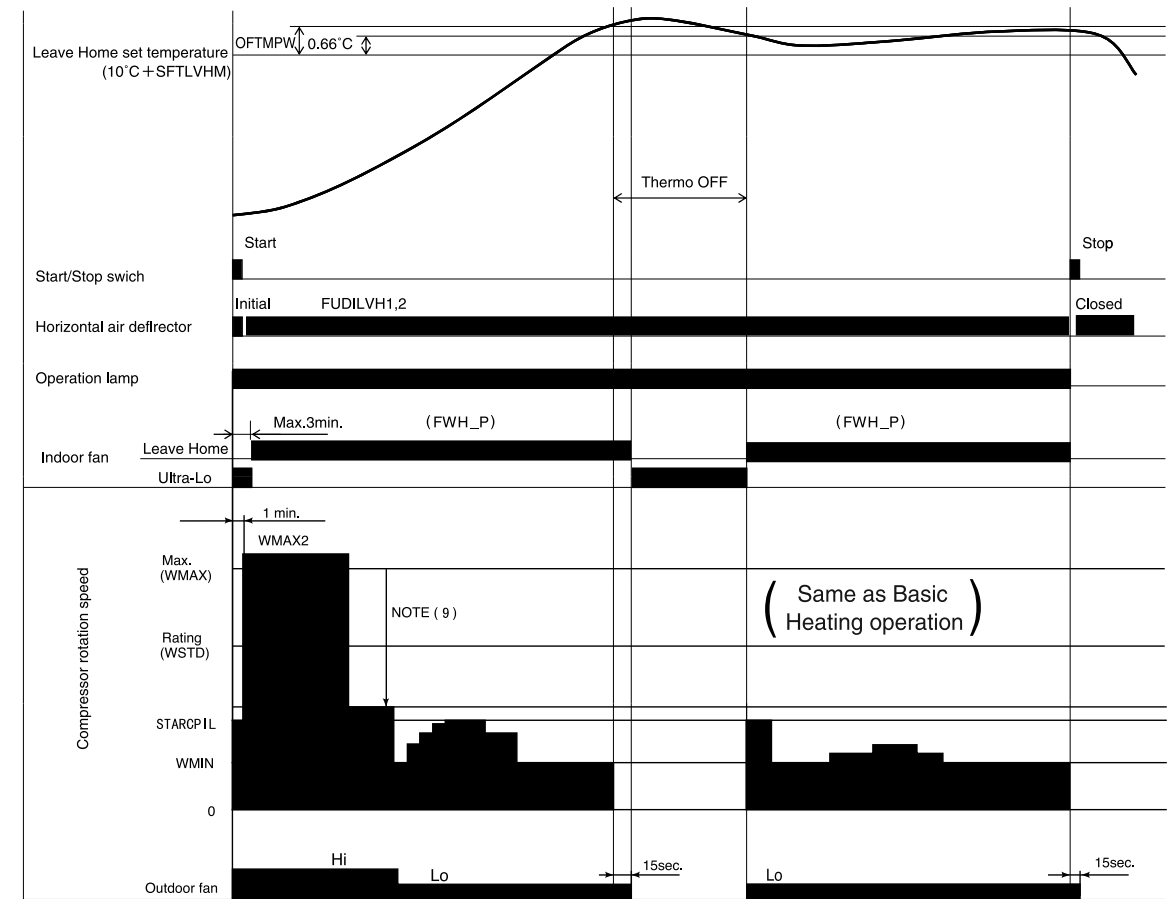

Notes:

Perform Leave Home operation according to the following control contents.

- (1) Operation mode : Heating
- (2) Setting temperature : 10°C
- (3) Shift value : + SFTLVHM
- (4) Indoor fan speed : FWH_P
- (5) Outdoor fan speed :
- (6) Compressor start control: } Same as Basic Heating operation
- (7) Compressor speed : }
- (8) Operation lamp : ON

ECO

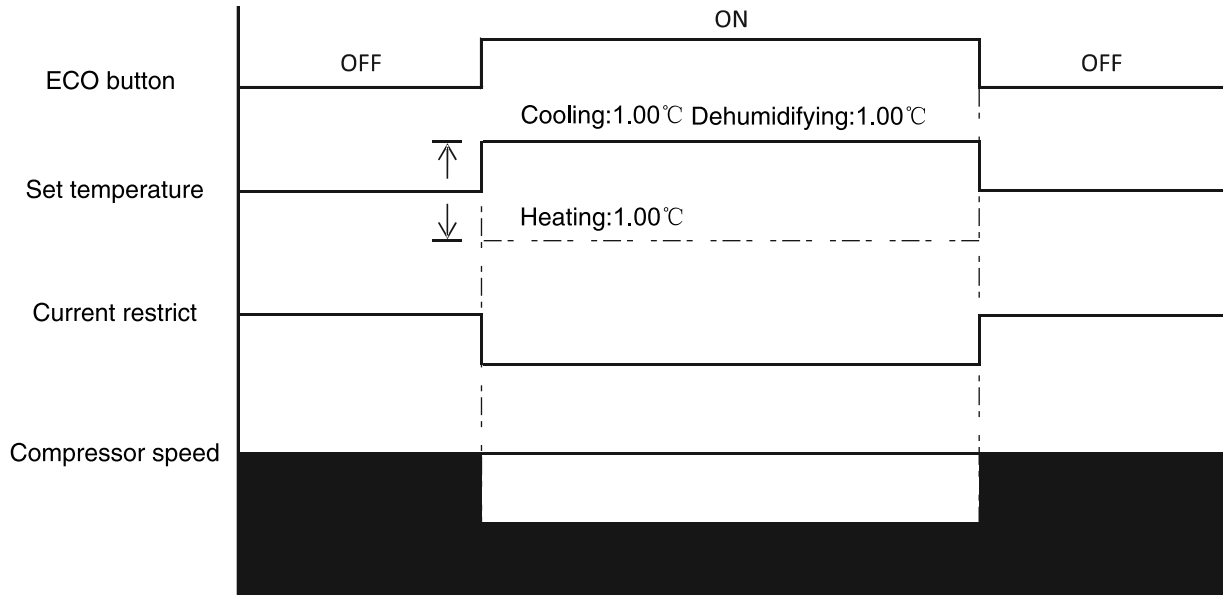

Notes:

- Can't set POWERFUL and ECO at the same time.
- During FAN operation, can't set ECO.

ECO Operation (With Motion Sensor)

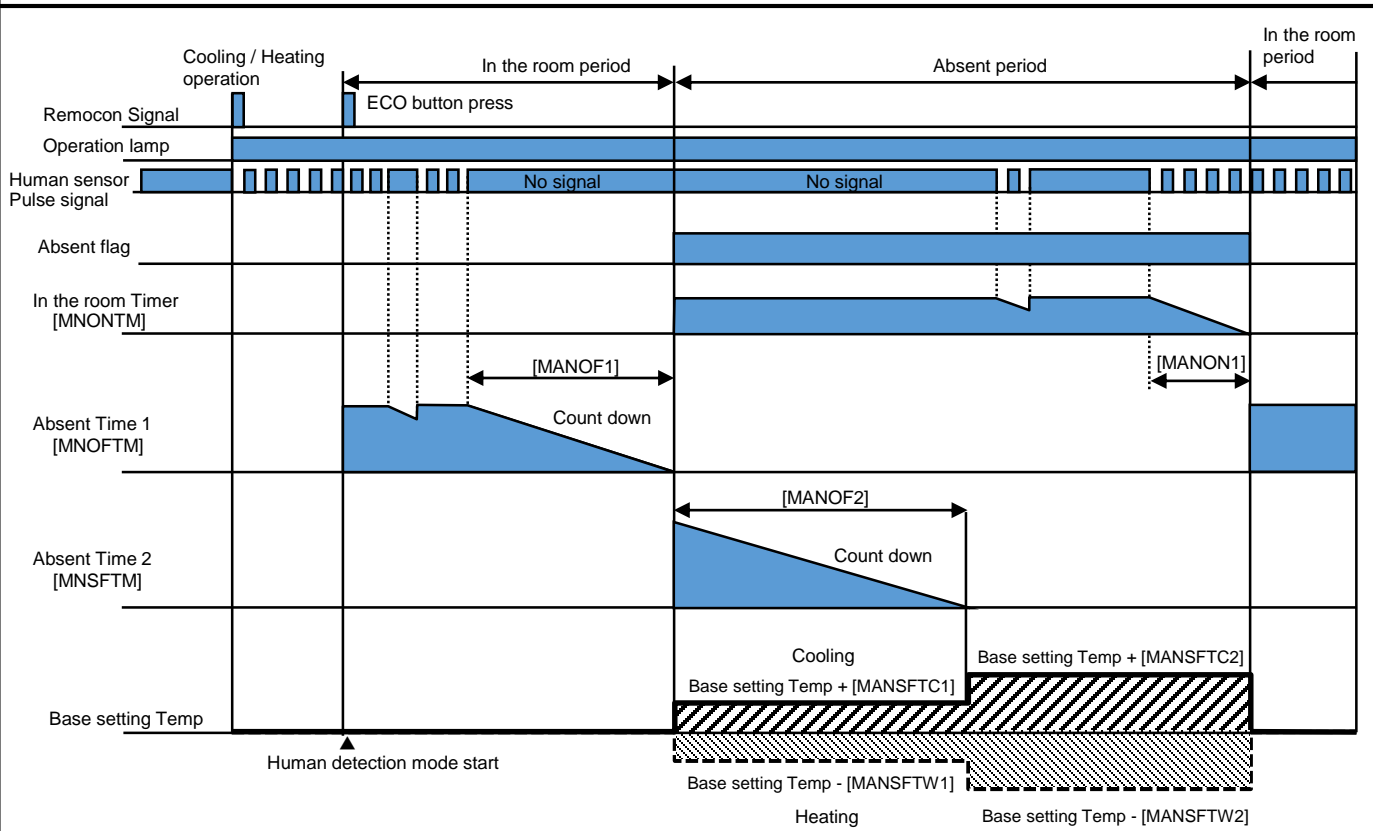

Notes :

1. ECO and POWERFUL cannot operate at the same time
2. ECO is not available during FAN operation.

REFRIGERATING CYCLE DIAGRAM

RAD-50PPD / RAC-50NPD
 RAD-60PPD / RAC-60NPD

COOLING, DEHUMIDIFYING, DEFROSTING

OUTDOOR UNIT

INDOOR UNIT

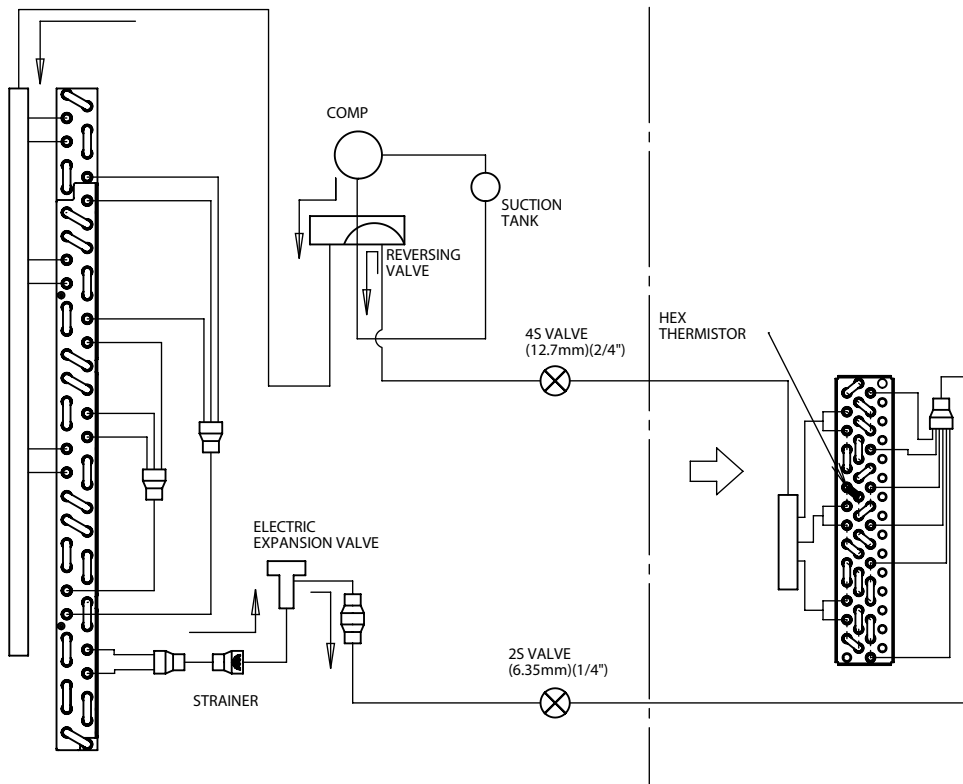

RAD-50PPD / RAC-50NPD
 RAD-60PPD / RAC-60NPD

COOLING, DEHUMIDIFYING, DEFROSTING

OUTDOOR UNIT

INDOOR UNIT

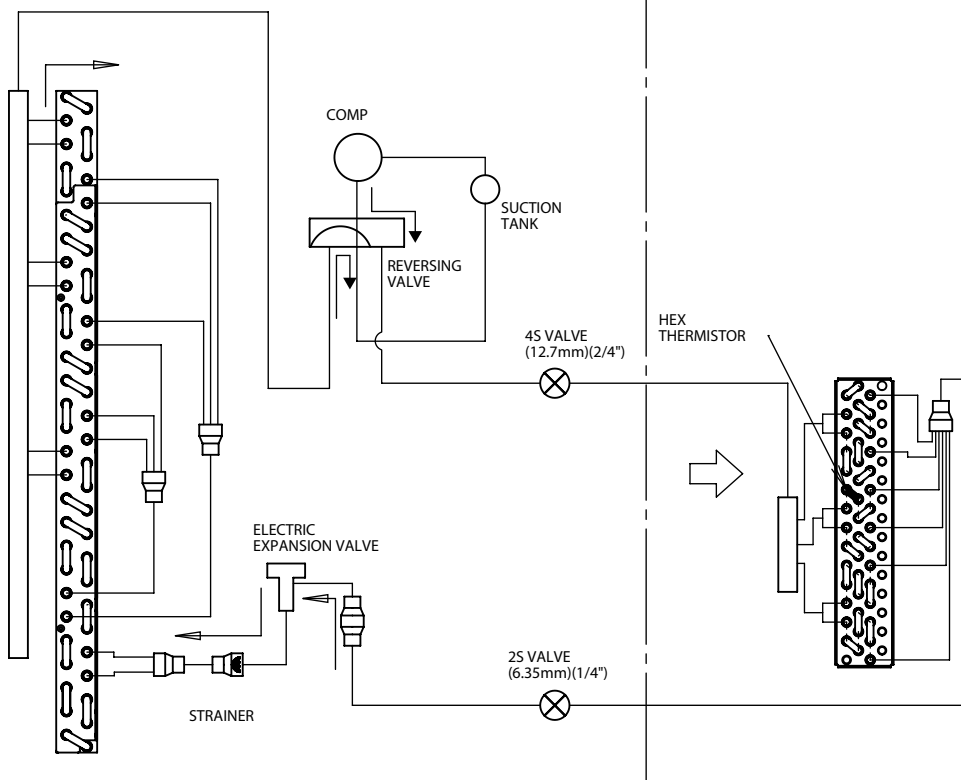

DESCRIPTION OF MAIN CIRCUIT OPERATION

■ RAD-50PPD, RAD-60PPD

1. Power control circuit

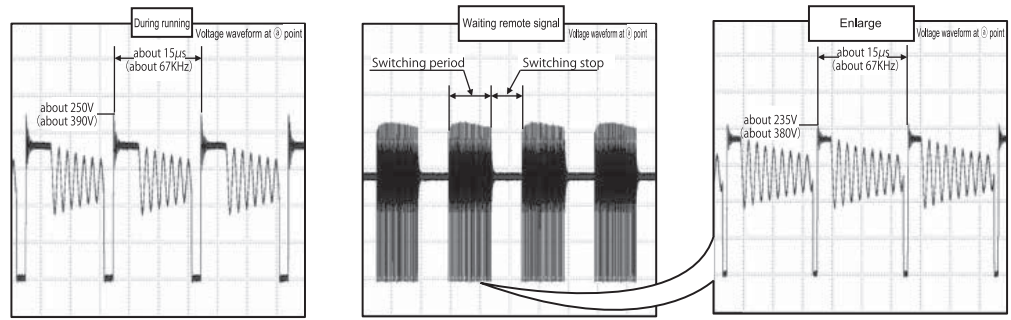

Indoor Fan Motor

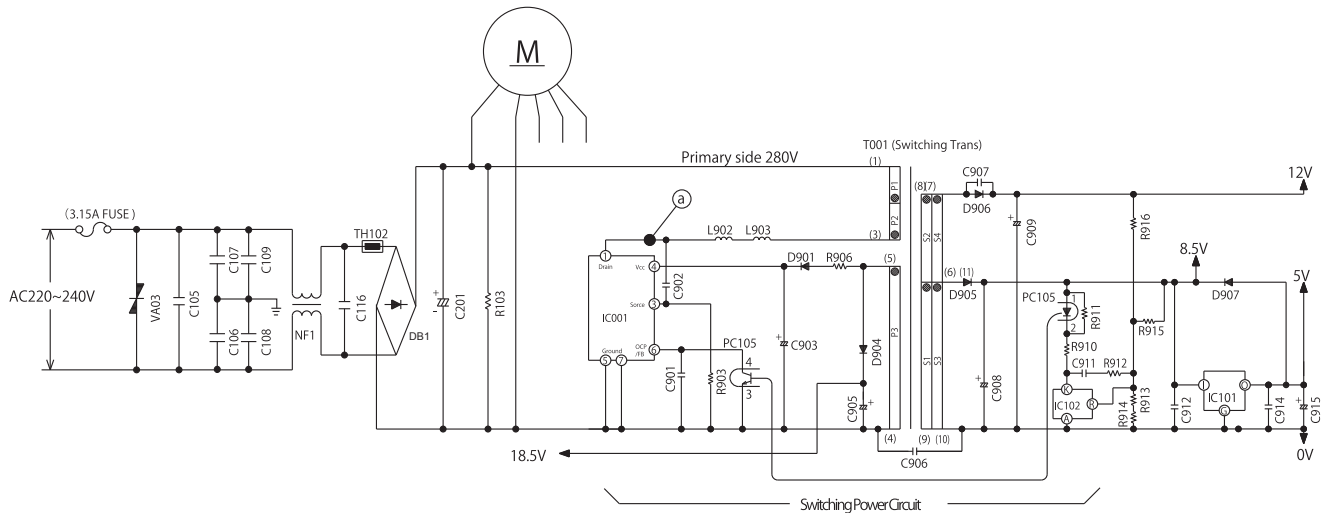

Fig. 1-1

- An AC power supply from outdoor unit flow through the 3.15A fuse, varistor (VA03), then filtered by noise filter circuit, rectified and smoothed by DB1 and C201 to a DC current 311V to 325V. Then it is supplied to the indoor fan motor drive circuit and switching power circuit.
- The switching power circuit, as controlled by IC001, drives the primary winding of the transformer (T001) to produce a specified voltage at the output winding. [The output terminal (pin ①) of IC001 has a switching voltage as shown in Fig. 1-1 but it changes in voltage peak and oscillation period depending on the power load. While on standby for a remote control signal, in particular, the oscillation frequency is lowered to a level as low as 20 kHz or so to reduce the standby power.]
- The outputs of the output windings of the transformer is rectified and smoothed to become DC voltages at primary 18.5V, 12V, and 8.5V respectively. The primary 18.5V is supplied to the drive circuit of the indoor fan motor, the 12V is supplied to each vane motor and to the drive circuits of the cleaning unit driving motor and other equipment, and the 8.5V is adjusted to a stable 5V by the 3-terminal regulator IC (IC101) and supplied to the microcomputer peripheral circuit.

Check

If a failure in a part or circuit has produced an abnormal current in the power supply, the 3.15A fuse will blown to prevent further damage. If the 3.15A fuse blown, check the indoor fan motor, switching electrical circuit, and other components and replace any defective part.

Check

If an abnormally high voltage is applied to the power supply, the 3.15A fuse and varistor (VA03) will prevent further damage. If a high voltage results in the 3.15A fuse blown, the varistor (VA03) should have deteriorated and destroyed. Therefore replace it at the same time.

Caution

The primary circuit of the transformer (T001) has a voltage to ground. Guard against electric shocks.

Caution

Even the breaker is OFF, the high voltage is still exist on the board. Make sure to wait for 15 minutes or more before start the part replacing work.

2. Drive circuit of the indoor fan motor

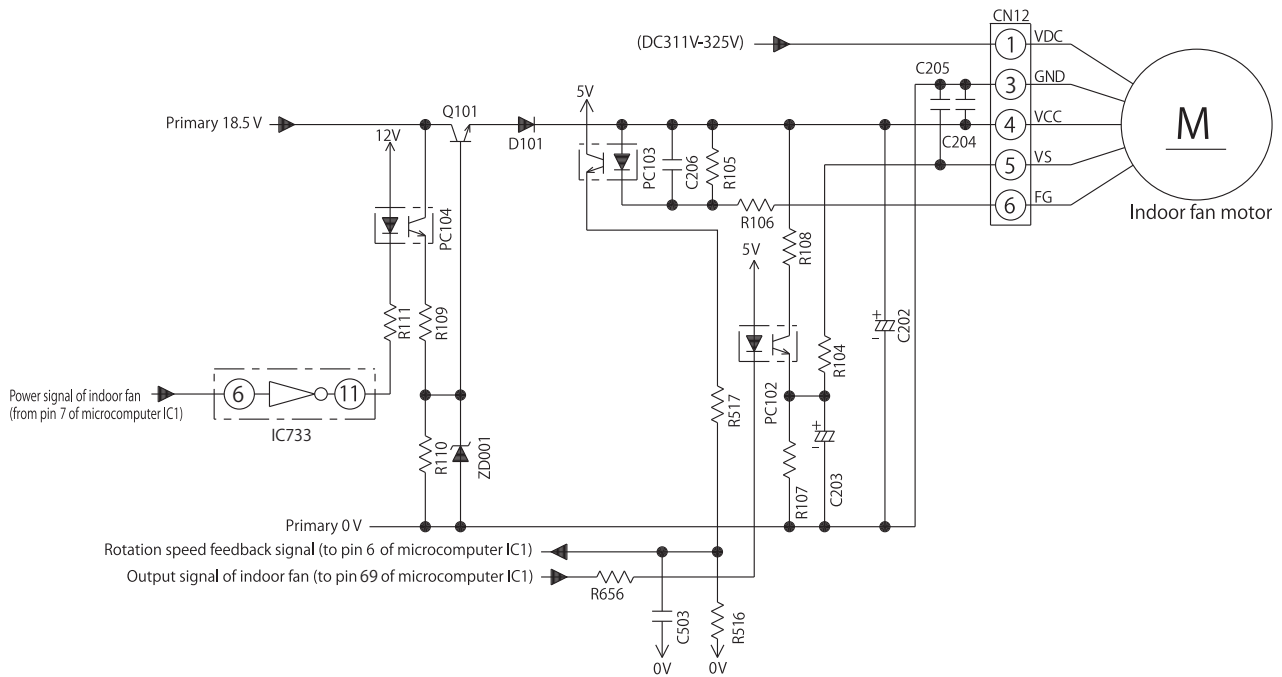

Fig. 2-1

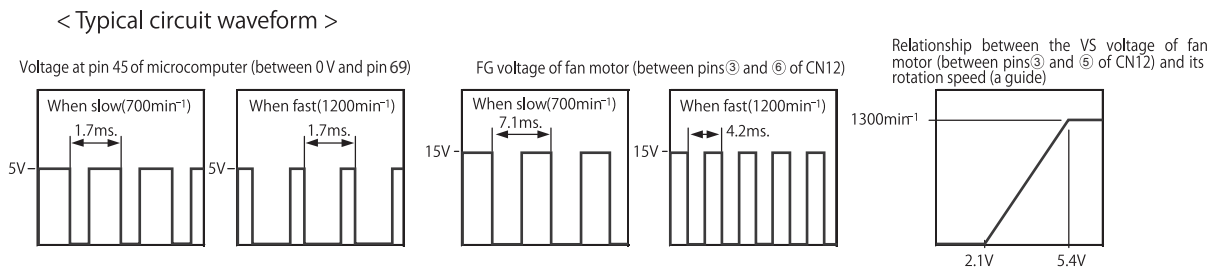

Fig. 2-2

- The indoor fan motor DC Voltage (VDC), Control Circuit Voltage (VCC), and Speed Control Voltage (VS) are supplied from connector CN12. FG is a feedback signal for an indoor fan motor frequency of rotation speed.
- Primary 18.5V flows through a converter circuit and steps down to 5V.
- While the remote control signal is on Standby, Q101 acts as a switch and cuts off the supply for VCC. Hence it will reduce power consumption during standby.
- The VS is controlled by the microcomputer (IC1). The VS terminal undergoes an analog voltage that matches the LO pulse signal at pin 69 of the microcomputer (IC1). (See Fig. 2-2.)
- The FG feedback signal sends 12 pulses per revolution of the motor shaft. By counting the pulse frequency rate, the microcomputer (IC1) recognizes the motor speed, thereby performing feedback control.

Caution

The indoor fan motor and drive circuit are connected to the primary power supply. Do not perform safe work practices to avoid electric shock.

Caution

Do not plug/unplug the connector when the unit is power ON. Doing so may cause the indoor fan motor and board circuit to be damaged. Perform the repair work after sufficiently discharging. Insufficient capacitor discharge may cause an electric shock.

3. Remote control reception circuit

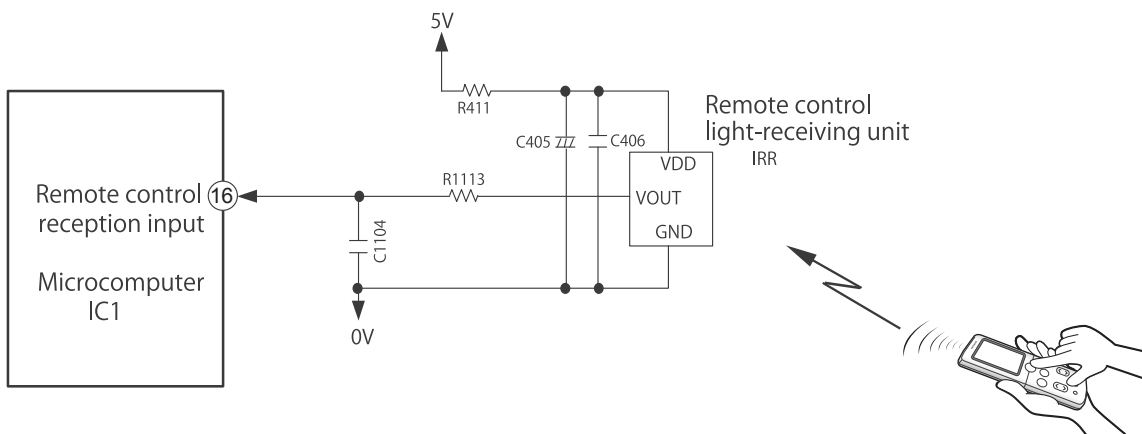

Fig. 3-1

[Typical communication waveform]

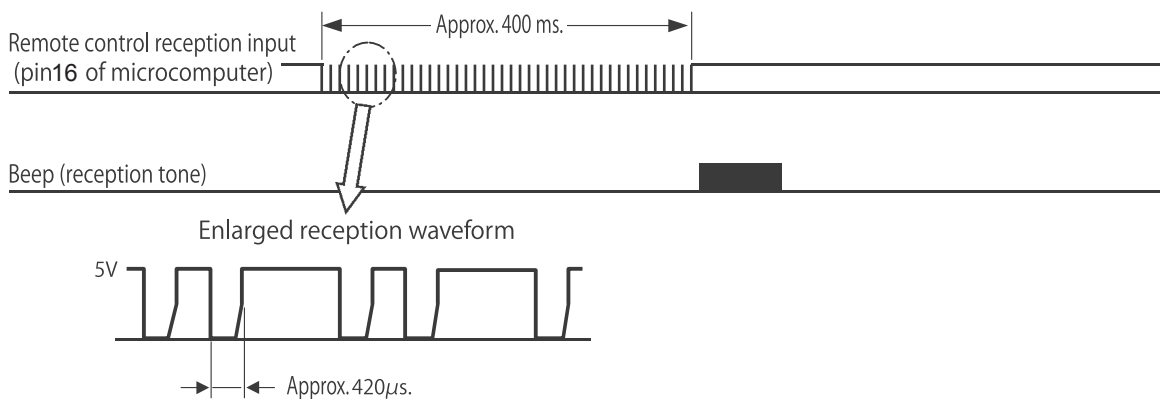

Fig. 3-2

- An infrared signal from the remote control unit is converted to an electrical signal by Remote Control Light-Receiving Unit (IRR) and send to microcomputer (IC1). Data is transmitted in digital data "0" and "1" by changing the interval of the basis pulses at about 420 μ s.

4. Indoor/outdoor communication circuit

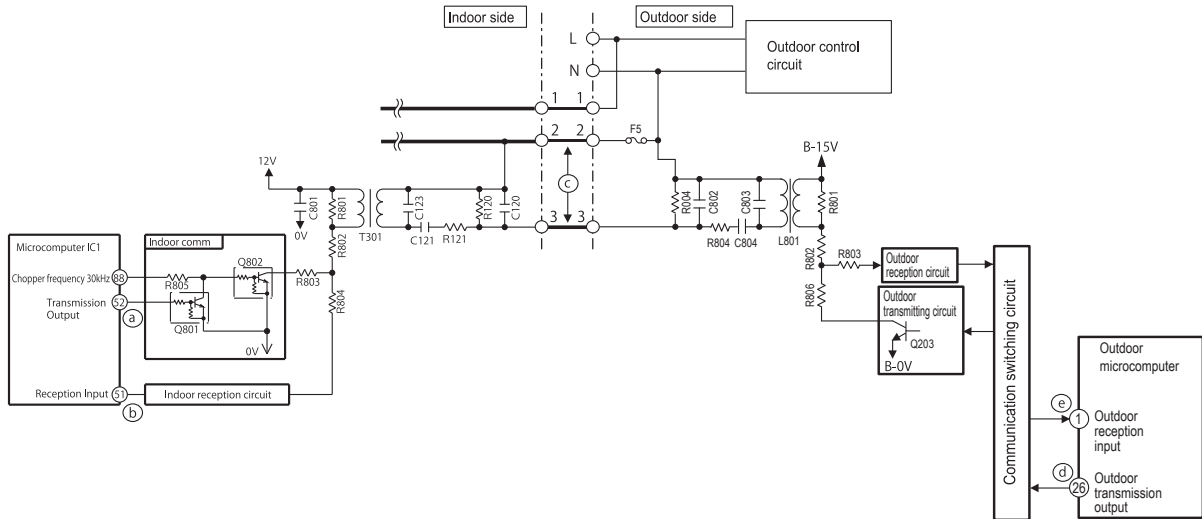
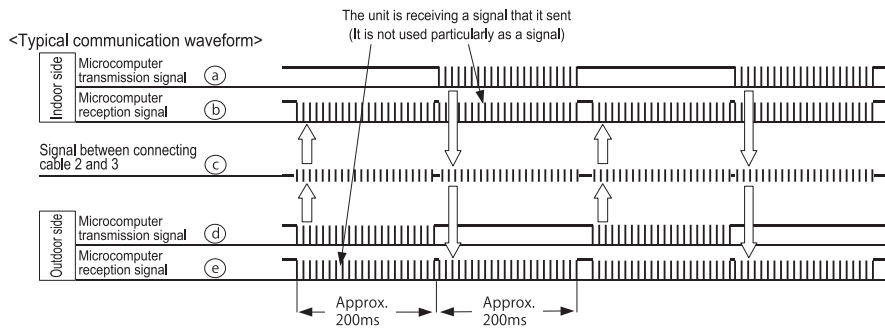

Fig. 4-1



<Enlarged waveform>

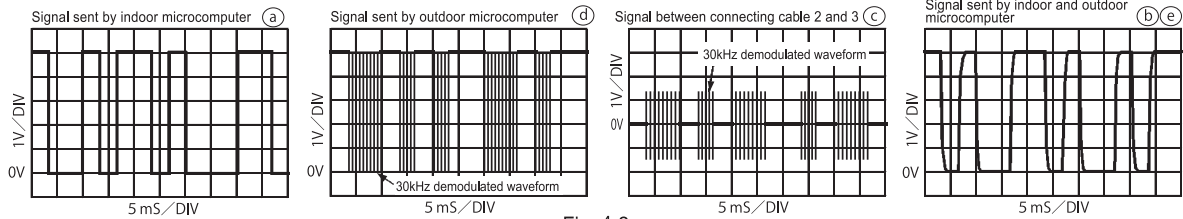

Fig. 4-2

- * Indoor and outdoor communications are conducted by using lines 2 and 3 of connecting cable. Line 2 of connecting cable is share with a transmission channel that powers the indoor unit.
- * Data communicated between the indoor and outdoor units are outputted from the microcomputer as serial signals and are transmitted as demodulated by a 30kHz carrier wave.

Check

If the communication fails between the indoor and outdoor units for some reason, the product will give a self-diagnosis display either by "the timer lamp blinking 3 times" or "the the timer lamp blinking 12 times" depending on the cause.

Check

If a cable poorly inserted in the indoor terminal board or some other failure overheats the terminal board and the temperature fuse of the terminal board blows out, the power to the indoor communication circuit will be shut down to stop the communications function. (In that case, the failure will be displayed by the timer lamp blinking 3 times.)

Check

If communication fails between the indoor and outdoor units for some reason, the product will give a self-diagnosis display either by "the timer lamp blinking 3 times" or "the timer lamp blinking 12 times" depending on the cause.

Indoor/Outdoor communication fault circuit judgement

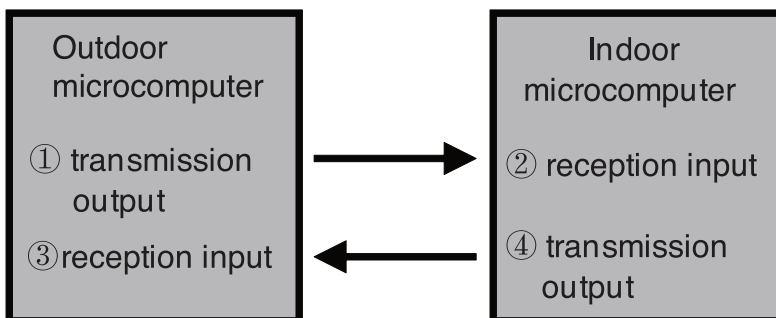

1. Failure happen during unit running

- 【If ① failure】 Outdoor: LD301 blinking 9 times / Indoor: no failure display
- 【If ② failure】 Outdoor: LD301 blinking 9 times / Indoor: the timer lamp blinking 3 times
- 【If ③ failure】 Outdoor: LD301 blinking 9 times / Indoor: no failure display
- 【If ④ failure】 Outdoor: LD301 blinking 9 times / Indoor: the timer lamp blinking 3 times

2. Failure happen during standby mode but outdoor unit not yet enter hibernation mode

- 【If ① failure】 Outdoor: LD301 blinking 9 times / Indoor: the timer lamp blinking 12 times
- 【If ② failure】 Outdoor: LD301 blinking 9 times / Indoor: the timer lamp blinking 3 times
- 【If ③ failure】 Outdoor: LD301 blinking 9 times / Indoor: the timer lamp blinking 12 times
- 【If ④ failure】 Outdoor: LD301 blinking 9 times / Indoor: the timer lamp blinking 3 times

3. Failure happen during standby mode but outdoor unit already enter hibernation mode

- 【If ① failure】 Outdoor: no failure display / Indoor: the timer lamp blinking 12 times
- 【If ② failure】 Outdoor: no failure display / Indoor: the timer lamp blinking 3 times
- 【If ③ failure】 Outdoor: no failure display / Indoor: the timer lamp blinking 12 times
- 【If ④ failure】 Outdoor: no failure display / Indoor: the timer lamp blinking 3 times

When outdoor unit is in hibernation mode, outdoor microcomputer is off, so the outdoor unit can't display the failure.

5. Room temperature heat exchanger thermistor circuit

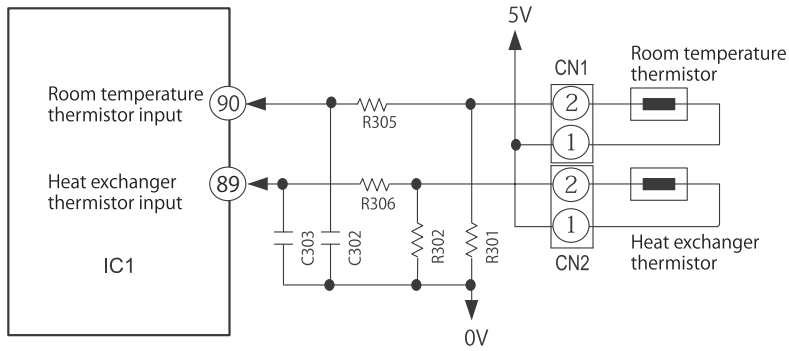

Fig. 5-1

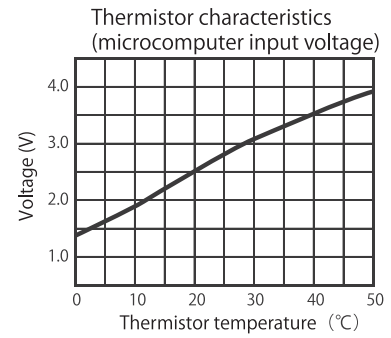

Fig. 5-2

- The room and indoor heat exchanger pipe temperature are detected by Room Temperature Thermistor and Heat Exchanger Thermistor.
- A thermistor is an electrical resistor whose resistance is reduced by the heat. Analog voltages obtained by the resistance voltage is divided with the fixed resistor recognized by the microcomputer (IC1) as temperature signals.
- The relationship between the thermistor temperature and circuit voltage is roughly as shown in Fig. 5-2. If it is easier to take actual measurements between the terminals of CN1 and CN2, refer chart in Fig. 5-3 "Voltages between Thermistor ends."

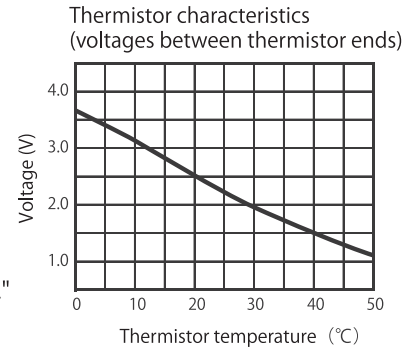

Fig. 5-3

6. Float switch

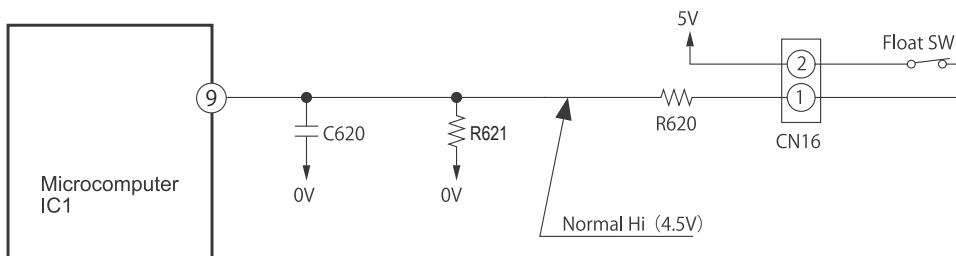

Fig. 6-1

- It is a float type switch used to observe the drain water level in the drain pan. This switch will be activated and forced the unit to stop when abnormal water level is detected caused by drain pump broken or blocked drain hose failed to suck the water out.
- During float switch operated, timer lamp will blink 6 times. Please take note that the switch will also activated when float switch connector is not inserted properly of the lead wire is shorted.

7. Drain pump driven circuit

- During cooling and dry mode, microcomputer pin 62 will become Hi and turned ON the drain pump relay to driven the drain pump motor.

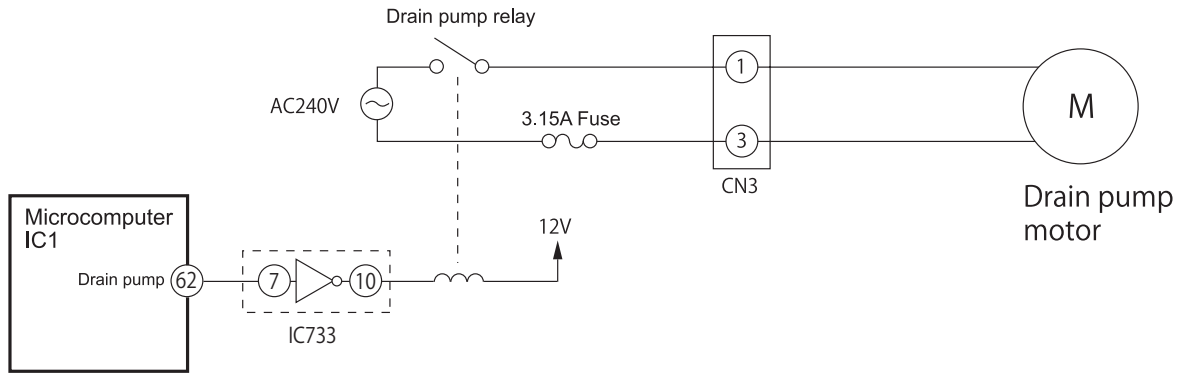

Fig. 7-1

8. Drain pump test switch

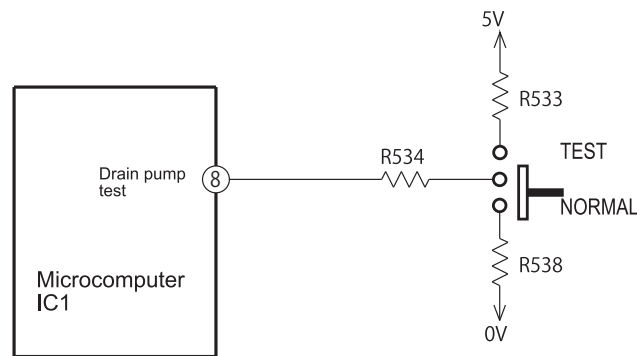

Fig. 8-1

- It is a switch to turn ON the drain pump for testing purpose. When select the switch to test position, drain pump motor will operate and timer lamp will blink 7 times. During this time, remote control signal will not receive.

9. High static pressure switch (Full duct type and semi duct type)

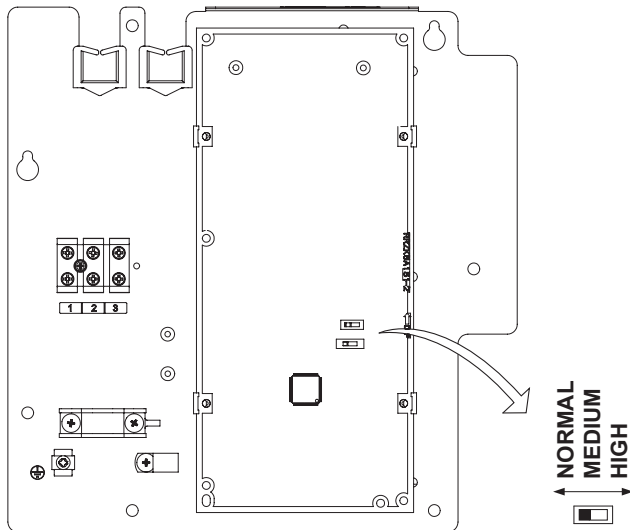

Fig. 9-1

- For full duct type, set the switch to High position. For semi duct type, set the switch to Medium position.
- If not set to High or Medium, there will be reduction of cooling and heating capacity.

10. Wired remote control reception and transmission circuit.

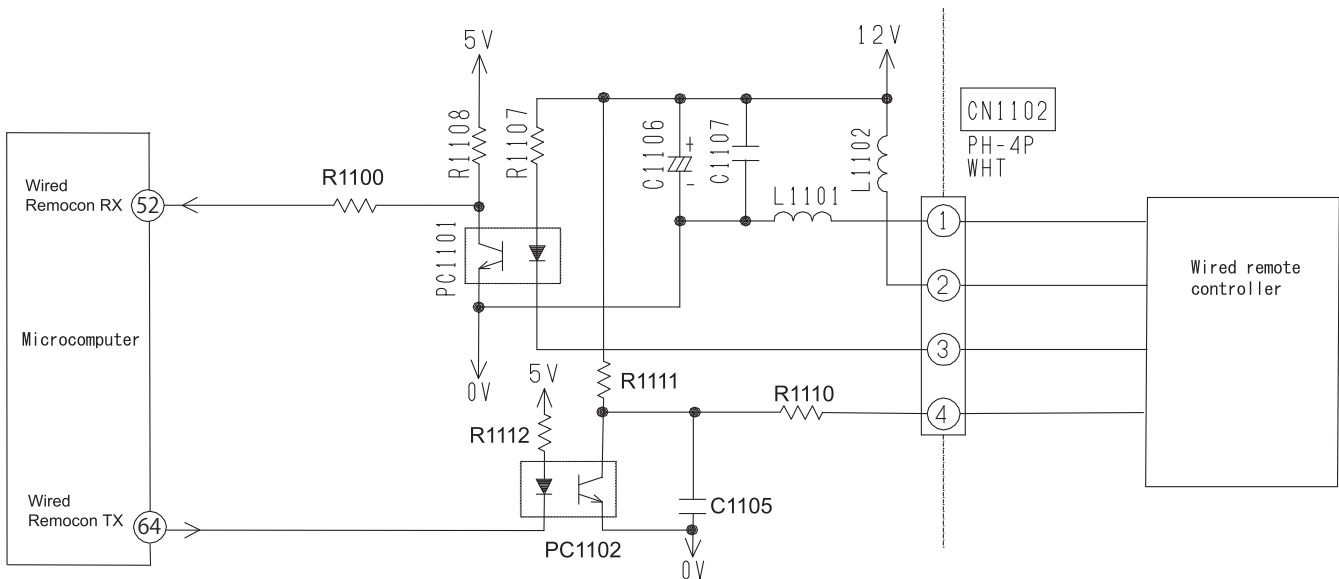

Fig. 10-1

- In wired remote control circuit, the signal will transmit to microcomputer pin 52 by using photocopier PC1101 and receive from microcomputer pin 64 by using photocopier PC1102.

11. Dip switch

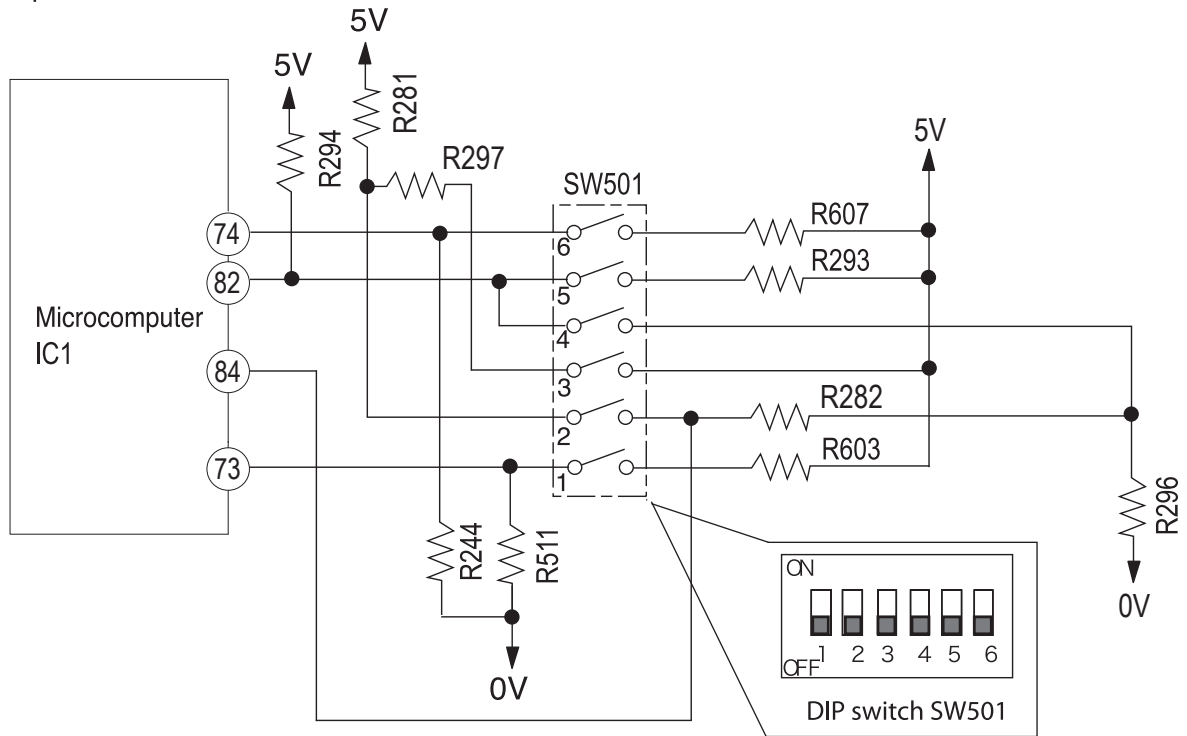

Fig. 11-1

- Fig.11-1 shows the dip switch circuit. The table shown in Fig.11-2 are function and setting position from ① - ⑥ of the switch number.

SW No.	ITEM	FUNCTION							
		OFF	ENABLE	ON	DISABLE				
1	AUTO RESTART	OFF	ENABLE	ON	DISABLE				
2	CARD KEY MODE	OFF	DISABLE	ON	ENABLE				
3	CARD KEY LOGIC SELECT	OFF	INPUT HIGH ACTIVE	ON	INPUT LOW ACTIVE				
4	HEATING/COOLING ONLY MODE SELECT	OFF	HEATING & COOLING	OFF	HEATING ONLY	ON	COOLING ONLY	ON	HEATING & COOLING
5	HEATING/COOLING ONLY MODE SELECT	OFF		ON		OFF		ON	
6	NOT USED								

Fig. 11-2

NOTE :

1. All switch set to OFF position (Factory setting).
2. If the dip switch set to "Heating mode only" or "Cooling mode only", the wireless remote controller must be set to operation mode lock setting as indicated on page 119.

12. Run status and alarm signal output circuit

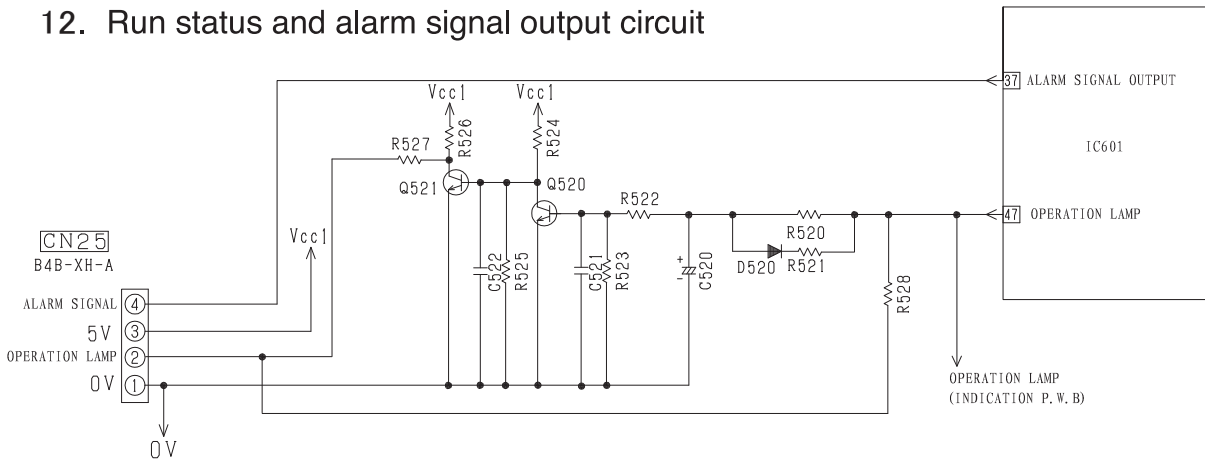

Fig.12-1

Fig.12-1 is the control circuit of run status and signal output in main PWB. The pin ② of CN25 is used to show run status and the pin ④ of CN25 is used to warn people when failure occurrence. If customer want to use this function, need to use the adapter(sold separately) to achieve it. the adapter is optional and the detail circuit refer to following circuit.

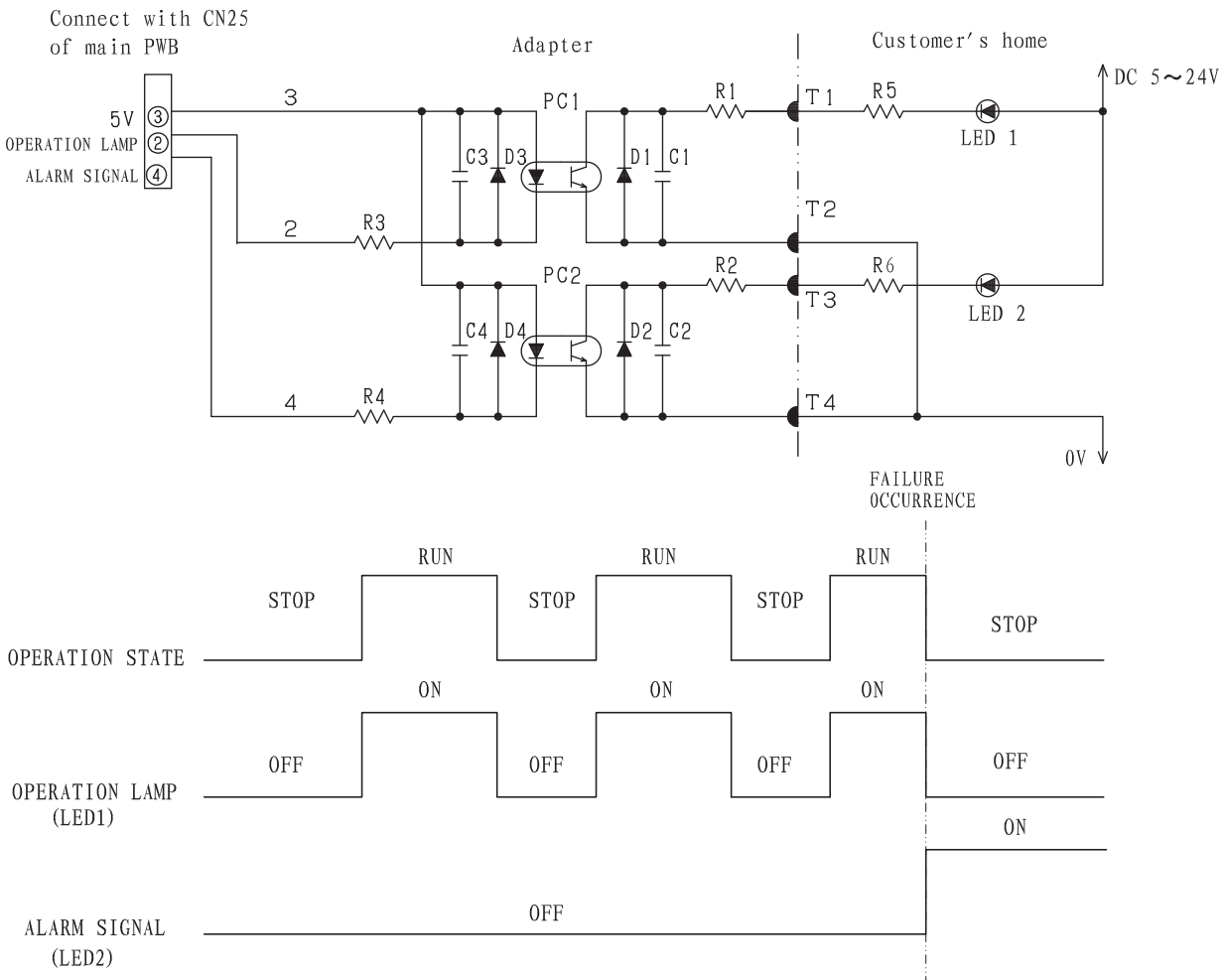

Fig.12-2

LED1 is on When air-condition is running and is off When air-condition is stopping. We can know the status of air-condition by LED1. LED2 is off When air-condition in normal condition and is on when air-condition in failure occurrence, we can repair it in time. The brightness of the lamp (LED1, LED2) can be determined by adjusting the resistance (R5, R6) value.

※ The adapter must be used because of noise interference. The noise will cause air-condition failure. the voltage from customer's home supply to adapter must be in the 5~24V, the current is less than 10mA. If the voltage is lower than 5V, optocouplers will not be action; once the voltage is higher than 24V, optocouplers adapter will be damaged.

DESCRIPTION OF MAIN CIRCUIT OPERATION

MODEL RAC-50NPD / RAC-60NPD

1. Power Circuit

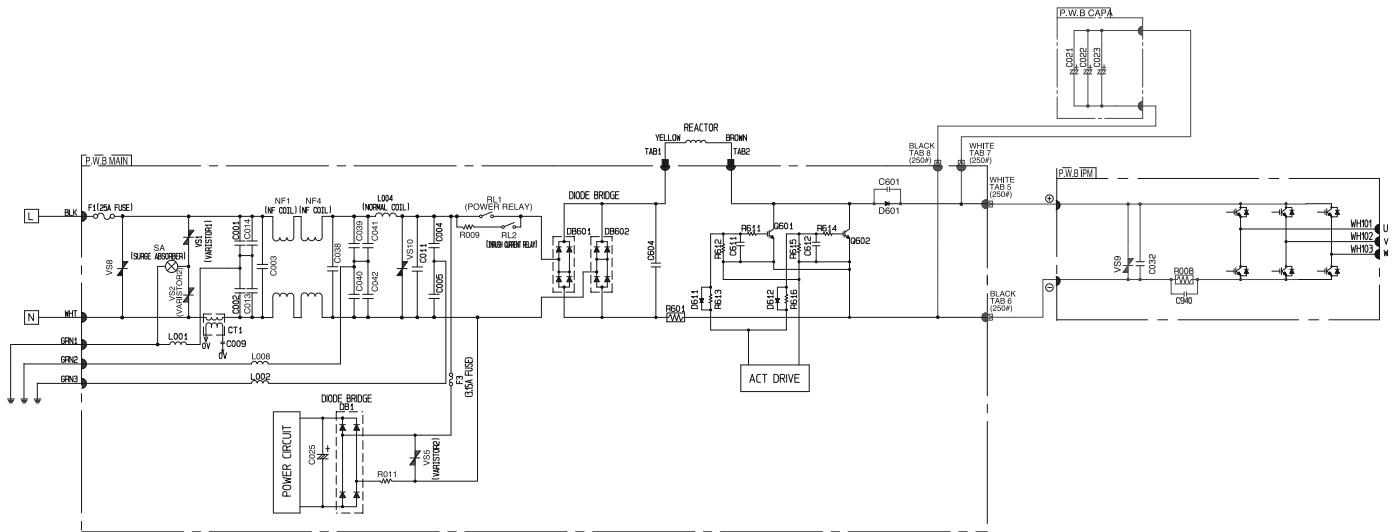

Fig 1-1

※ This circuit full-wave rectifies 240VAC applied between terminals L and N and boosts it to a required voltage with the IPM to create a DC voltage.

The voltage become 320-360V when the compressor is operated.

※ Importance component

(1) Intelligence Power Module (IPM)

A module that constitute by an inverter part.

<Reference>

※ In case of Intelligence Power Module malfunction or connection failure immediately after compressor starts, its may stop due to error of [abnormal low speed], [switching failure],[Ip stop] and others.

(2) Diode Stack (DB1, DB601, DB602)

These rectify the 240VAC from terminal L and N to a DC power supply.

<Reference>

※ If diode stack (DB601, DB602) are faulty, DC voltage may not be generated and the compressor may not operate at all. Also be aware that the 3.15A fuse might have blown.

(3) Smoothing capacitors (C021-C023, 500μF 450V)

<Reference>

※ This smoothes (averages) the voltage rectified by the diode stack.

(4) IGBT to improve efficiency (Q601, Q602)

<Reference>

※ It will improve the efficiency during compressor load become heavy when current flow thru the chopper period of Q601, Q602

2. Power circuit (Low voltage)

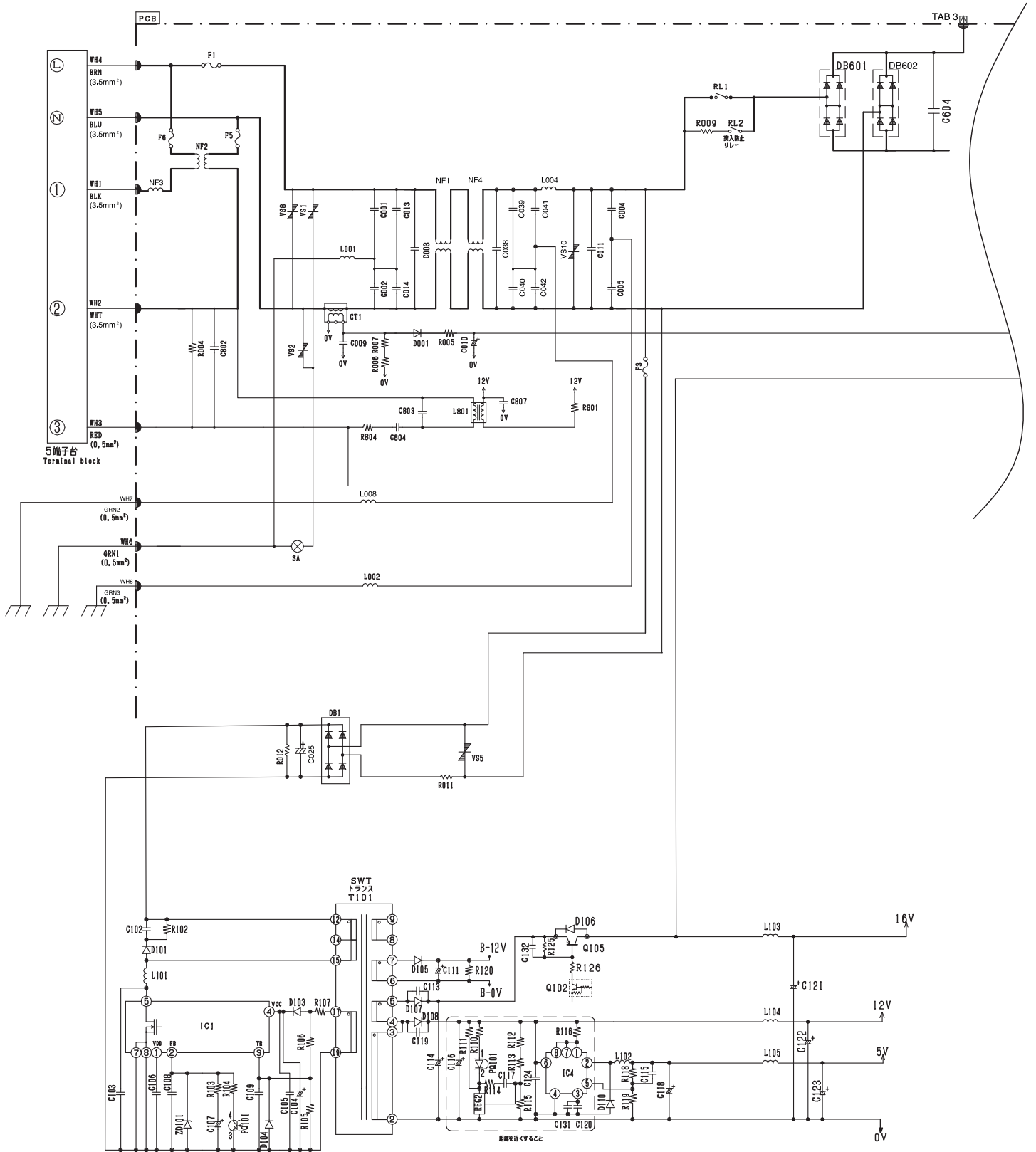

Fig. 2-1

- The 240V AC voltage is rectified to DC voltage (B-12V,16V,12V,5V) pass through switching control IC (IC1), switching transformer.
 - (1) B-12V Power supply for electrical expansion valve.
 - (2) 16V Power supply for IPM driver circuit of compressor and fan motor, IGBT action.
 - (3) 12V Power supply for 4 way valve relay, power relay, in rush current relay, motor current amplification,
 - (4) 5V Power supply for microcomputer, peripheral circuits.

Main parts

(1) C001,C002,C003,C004,C005,C011,C013,C014, C038, C039, C040, C041, NF1, NF2, NF3, NF4

These absorb electrical noise generated during operation of compressor and also absorb external noise entering from power line to protect electronic parts.

(2) Surge Absorber, Varistor1,2,5,8,10

These absorb external power surge.

(3) IC4

DC/DC converter IC (DC12V → DC5V).

3. P.W.B. for power circuit

Voltage specification of power circuit as shown in below table.

<Checking point>

Output	Spec	Main load	Measuring point	Example of possible failure mode.
5V O/P	$5 \pm 0.4V$	Micon, Thermistor	Tester \oplus : L105 (5V) Tester \ominus : R119 (0V)	Outdoor not operate, no blinking indication
12V O/P	$12 \pm 0.5V$	Micon, IC2, 3, 4 Relay circuit	Tester \oplus : L104 (12V) Tester \ominus : R119 (0V)	Outdoor not operate, no blinking indication
16V O/P	$15.5^{+1.5V}_{-1.0V}$	IPM for Comp IPM for DC fan	Tester \oplus : L103 (16V) Tester \ominus : R119 (0V)	Stop : LD301 2, 3, 4 or 12 times blinking
B-12V O/P	$13^{+2.5V}_{-1.0V}$	Expansion valve	Tester \oplus : R418 (B-12V) Tester \ominus : R120 (B-0V)	Stop : LD301 5 times blinking (related to refrigerant cycle error)

※ Power circuit for P.W.B can consider normal if the result is satisfied with above specification.

4. Reversing valve control circuit

This model reversing valve control used to control the relay ON/OFF of the reversing valve, and also control the coil of the reversing valve ON/OFF.

The relay ON/OFF has different type when in the different operation mode.

You can see each operation mode as follows. If the reversing valve not connected or all the condition not the same as follow, it may be something wrong with the reversing valve circuit.

Point operation mode		micon (28 pin - 0V	HIC (28 pin - 0V	CN2①- CN2④
		Cooling	Usual cooling	Hi
Heating	Usual heating	Lo	12V	AC240V
	Defrost	Hi	0V	0V

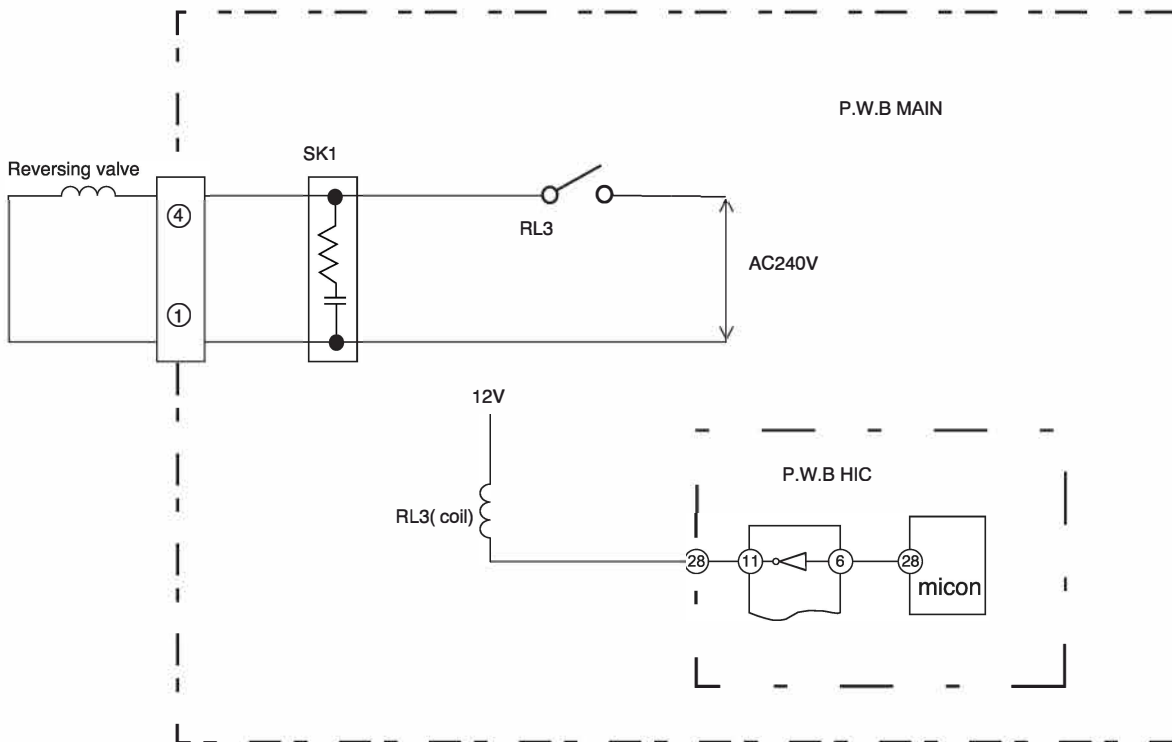

Fig.4-1

5. Temperature Detection Circuit

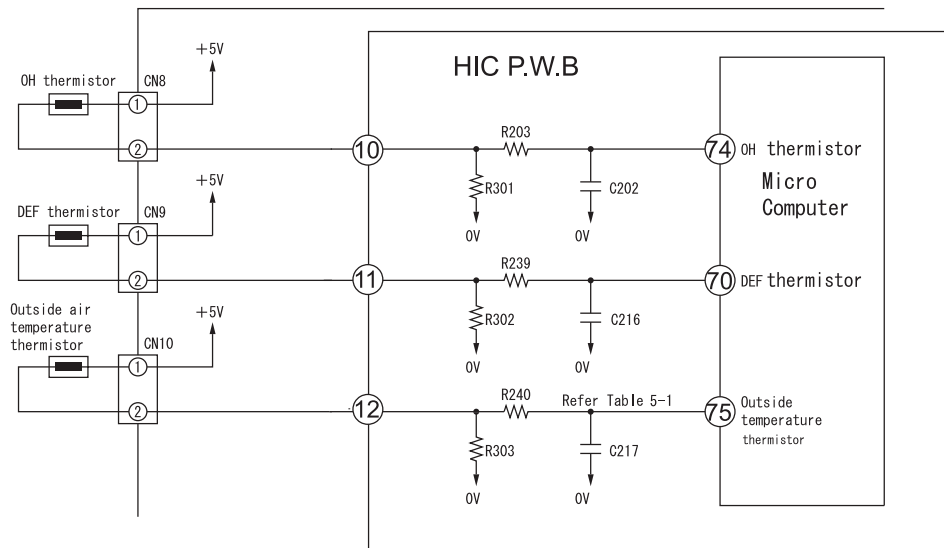

Fig.5-1

- OH thermistor circuit detect the temperature at the surface of compressor head, DEF thermistor circuit detect the defrosting operation temperature.
- A thermistor is a negative resistor element which has characteristics that the higher(lower) the temperature, the lower(higher) the resistance.
- When the compressor is heated, the resistance of the OH thermistor becomes low and $\oplus 5V$ is divided by OH thermistor and R301 and the voltage at pin ⑦④ of microcomputer.
- Compare the voltage at microcomputer pin ⑦④ and setting value stored inside. If the value exceed the set value, microcomputer will judge that the compressor is overheated and stop the operation.
- When frost is formed on the outdoor heat exchanger, the temperature at the exchanger drops abruptly. Therefore the resistance of the DEF thermistor becomes high and the voltage at pin ⑦① of micro computer drops. If this voltage becomes lower than the set value stored inside, microcomputer will enter the defrost control.
- During defrost operation, the microcomputer will transfer the defrosting condition command to indoor unit via SDO pin of interface of IF transmission output.
- The microcomputer read the outdoor temperature by Outside Air thermistor and transfer it to the indoor unit, thus controlling the compressor rotation speed according to the set value in the EEPROM of indoor unit and switching the operation mode (outdoor fan on/off etc.) to DRY mode.

Below table show the typical values of outdoor temperature in relation to the voltage.

Table 5-1

Outside Air Temperature (°C)	-10	0	10	20	30	40
Voltage at both side of R303 (V)	1.19	1.69	2.23	2.75	3.22	3.62

<Reference>

When the thermistor is open, open condition or disconnect, microcomputer pin 70, 74, 75 are approx. 0V; When thermistor is shorted, they are approx. 5V and LD301 will blink as below table:-

Table 4-2

Thermistor Condition	Thermistor	LD 301 Blinking		
		OH Thermistor	Outdoor Thermistor	Defrost Thermistor
Short		6 Times Blinking	7 Times Blinking	7 Times Blinking
Open		7 Times Blinking	7 Times Blinking	7 Times Blinking

6. Electric expansion valve circuit

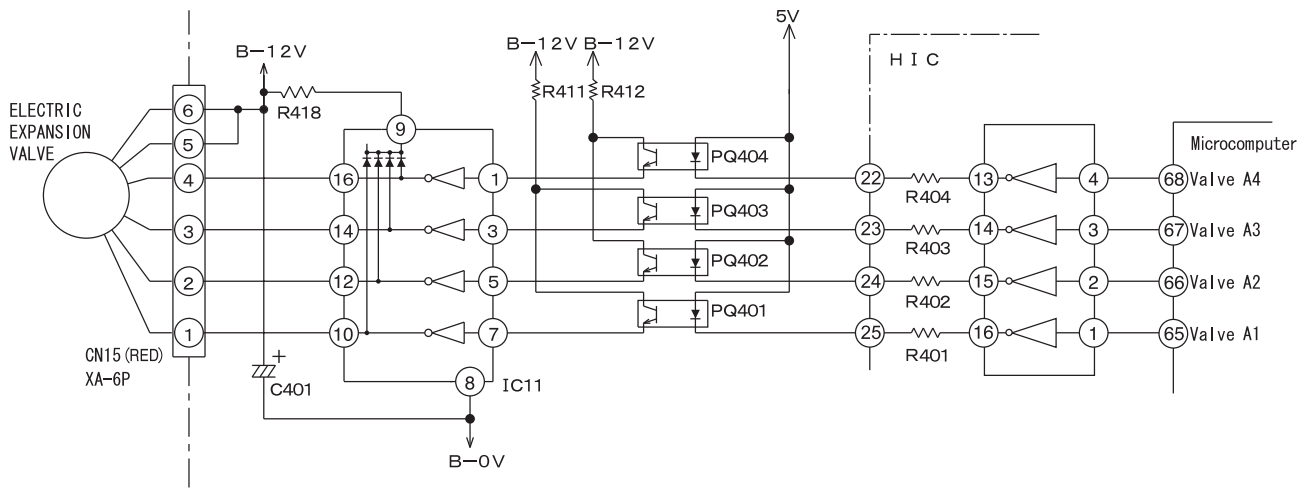

Fig. 6-1

- The electric expansion valve is driven by DC12V. Power is supplied to 1 or 2 phases of 4-phase winding to switch magnetic pole of winding in order to control the opening degree.
- Relationship between power switching direction of phase and open/close direction is shown below. When power is supplied, voltages at pins ④ to ① of CN15 are about 0.9V and 12V when no power is supplied. When power is reset, initial operation is performed for 10 or 20 seconds. During initial operation, measure all voltages at pin ④ to ① of CN15 by using a multimeter. If there is any pin with voltage that has not changed from 0.9V or 12V, expansion valve or microcomputer is broken.
- Fig.6-2 shows logic waveform when expansion valve is operating.

Table 6-1

CN15 pin no.	Wire	Drive status							
		1	2	3	4	5	6	7	8
①	WHT	ON	ON	OFF	OFF	OFF	OFF	OFF	ON
②	YEL	OFF	ON	ON	ON	OFF	OFF	OFF	OFF
③	ORG	OFF	OFF	OFF	ON	ON	ON	OFF	OFF
④	BLU	OFF	OFF	OFF	OFF	OFF	ON	ON	ON

Operation mode
 1→2→3→4→5→6→7→8 VALVE CLOSE
 8→7→6→5→4→3→2→1 VALVE OPEN

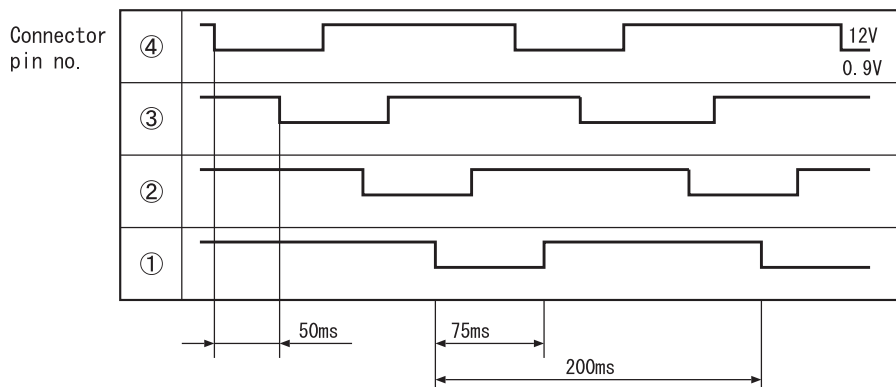

Fig. 6-2

With expansion valve control, opening degree is adjusted to stabilize target temperature by detecting compressor head temperature. The period of control is about once per 20 seconds and output a few pulse.

7. Outdoor DC fan motor control circuit

- This model is built with DC fan motor control circuit inside outdoor electrical unit.

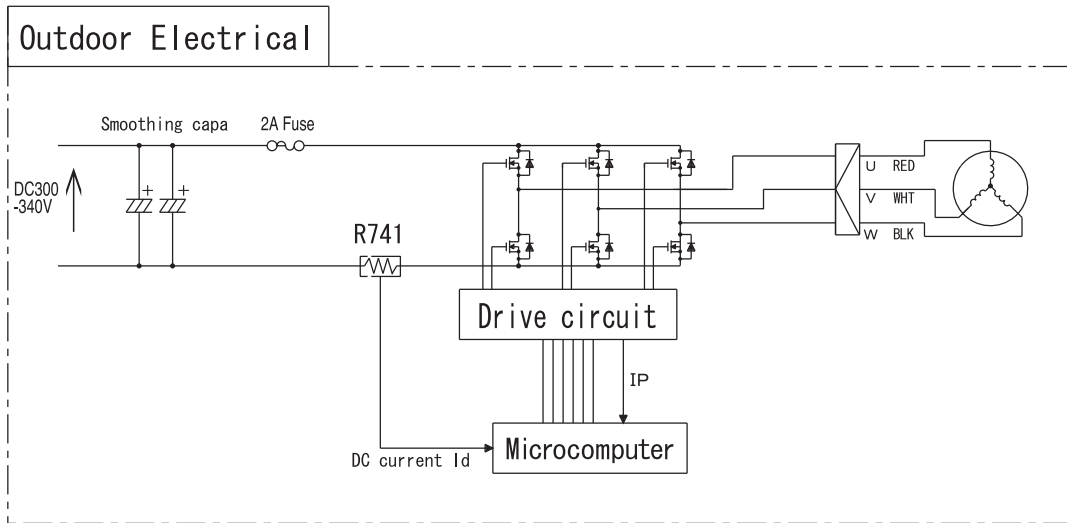

Fig 7-1

This DC fan motor is control by outdoor microcomputer that follow the operating instruction received from indoor microcomputer. The DC current that flow from R741 will presume actual operation speed and control the rotation to follow the operating instruction. Based on this DC current it will detect a over current and other fan motor failure.

(1) Fan motor speed controller during starting

Due to the interference of strong wind etc., operation movement is changed based on fan direction and rotation speed as shown below during starting of operation.

In addition, the fair wind is define as wind that blow to outside direction using Mouth Ring part. At strong and contrary wind ... The rotational speed is not controlled as to protect the equipment and fan will rotate reversely depend on the wind. Automatically start when wind condition become weak.

At contrary wind ... The rotational speed is controlled in fair wind direction after it slowly reduce the speed and finally stop.

At fair wind ... The rotational speed is controlled as it is.

At strong fair wind ... The rotational speed is not controlled as to protect the equipment and fan will rotate reversely depend on the wind. Automatically start when wind condition become weak.

(2) Fan motor speed controller during unit operating

There is a case where fan rpm is reducing during rotating caused by interference of strong wind. If this condition continue in long period, fan will stop rotating. (LD301 : 11 times blinking) The unit will restart according to control as per during start (1).

(3) Method of confirming self diagnosis LD301 lamp : 12 times blinking

If the unit stop and LD301 on the pwb blinking 12 times [fan lock stop is detected], follow below steps to confirm it.

1. Fan lock stop is detected when something has disturb the fan rotation by inserting material into propeller fan or ice has growing inside outdoor unit caused by snow.
Remove it if found something is bloking the fan.
2. Confirmed that CN24 connector is securely inserted. Fan lock stop is detected also when connector is not properly inserted. Please securely insert if found any disconnection.
3. Fan lock stop also can be detected where strong wind blown surrounding the unit.
Please confirm after restart the unit. (It may take few minutes to operate the compressor)
It is not a malfunction of electrical unit or fan motor if the unit run continuesly after restart the unit.
4. Check fan motor condition as below procedure.

[Checking Fan Motor] procedure

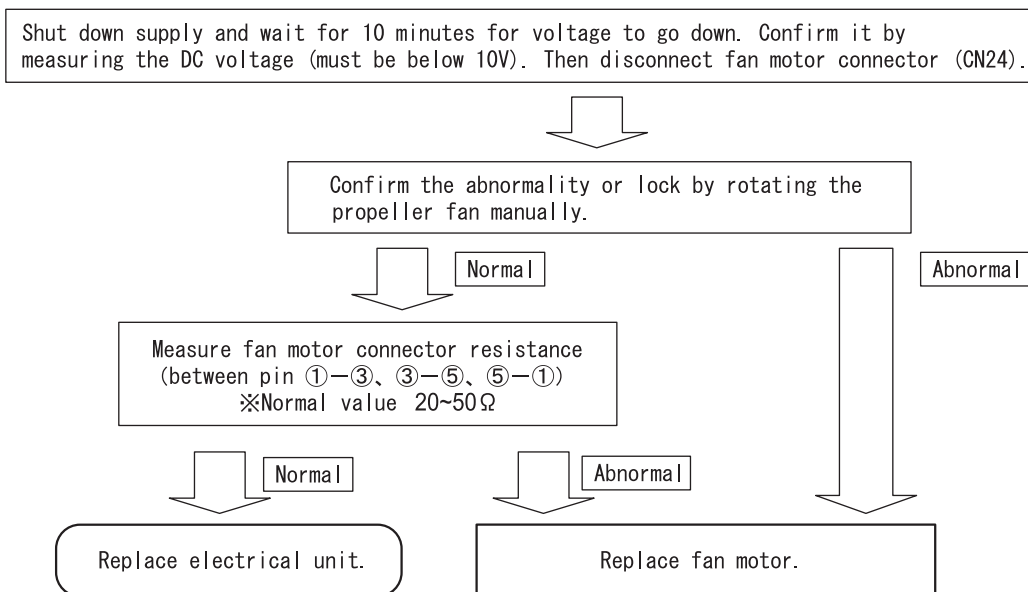

5. Reconnect again fan motor connector (CN24).

※Please confirm above checking procedure if found 2Afuse blown.

If fan motor is broken, replace both electrical unit and fan motor.

Caution

※Beware of electric shock due to high voltage when conducting an operation check.

Power supply for DC fan motor and compressor is common (DC260-360V).

9. Hibernation Mode

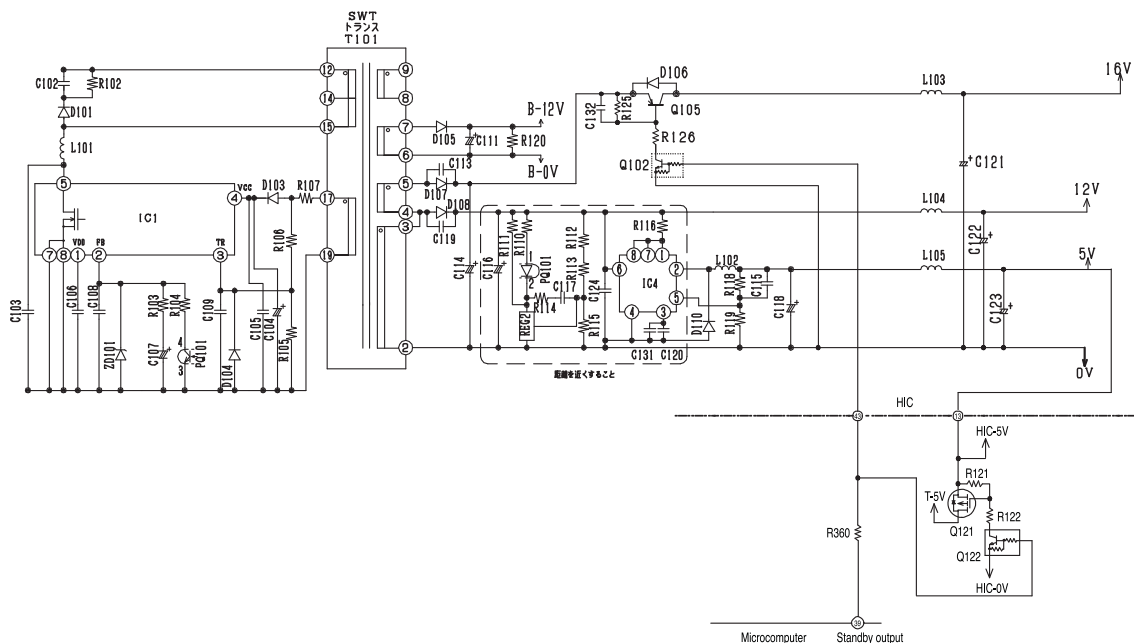

Fig. 9-1

- This model have designed to enter hibernation mode for energy saving and power consumption reduction during stanby.
- Unit will enter hibernation mode during below stanby condition if not received any signal from remote controller and expansion valve already completed initialization .
 - 1) Stanby continuesly
 - 2) Unit in running condition, then off the unit by remote controller and leave the unit in stanby condition.
- During hibernation activation, main microcomputer pin (39) will change to LOW condition. Due to this pin become LOW, Q121 and Q122 will be OFF. As Q121 OFF, T-5V will drop to 0V. Beside, Q102 and Q105 will be OFF and causing 16V also drop to 0V.
- During hibernation mode, DC voltage will be as below condition.
 - (1) B-12V : Maintain at 12V
 - (2) 16V : Drop to 0V
 - (3) 12V : Maintain at 12V
 - (4) 5V : Maintain at 5V
 LD301 on the Main P.W.B will be OFF during this mode.
- If outdoor unit have failure/error, all indication including error diagnosis LED will be OFF once the smoothing capacitor (C019 ~ C021) voltage reduce to 38.7V.
- For inspection during hibernation mode, service person can measure DC voltage B-12V, 12V and 5V on Main P.W.B. But to measure DC voltage 16V on Main P.W.B., service person shall on the indoor unit by remote controller first. This will change the unit from hibernation mode to normal.

SERVICE CALL Q & A

COOLING MODE

Q1 The compressor has stopped suddenly during cooling operation.



A1 Check if the indoor heat exchanger is frosted. Wait for 3-4 minutes until it is defrosted.

If the air conditioner operates in cooling mode when it is cold, the evaporator may get frosted.

DEHUMIDIFYING MODE

Q2 Sound of running water is heard from indoor unit during dehumidifying.



A2 Normal sound when refrigerant flows in pipe.

Q3 Compressor occasionally does not operate during dehumidifying.



A3 Compressor may not operate when room temperature is 10°C or less. It also stops when the humidity is preset humidity or less.

HEATING MODE

Q4 The circulation stops occasionally during Heating mode.



A4 It occurs during defrosting. Wait for 5-10 minutes until the condenser is defrosted.

Q5 When the fan speed is set at HIGH or MED, the flow is actually Weak.



A5 At the beginning of heating, the fan speed remains LOW for 30 seconds. If HIGH is selected, it switches to LOW and again to MED after additional 30 seconds.

Q6 Heating operation stops while the temperature is preset at "30".



A6 If temperature is high in the outdoor, heating operation may stop to protect internal devices.

AUTO FRESH DEFROSTING

Q7 After the ON/OFF button is pressed to stop heating, the outdoor unit is still working with the OPERATION lamp blinking.



A7 Auto Fresh Defrosting is carried out : the system checks the outdoor heat exchanger and defrosts it as necessary before stopping operation.

AUTO OPERATION

Q8 Fan speed does not change when fan speed selector is changed during auto operation.



A8 At this point fan speed is automatic.

NICE TEMPERATURE RESERVATION

Q9 When on-timer has been programmed, operation starts before the preset time has been reached.



A9 This is because “Nice temperature reservation” function is operating. This function starts operation earlier so the preset temperature is reached at the preset time. Operation may start maximum 60 minutes before the preset time.

Q10 Does “Nice temperature reservation” function operate during dehumidifying?



A10 It does not work. It works only during cooling and heating.

Q11 Even if the same time is preset, the operation start time varies.



A11 This is because “Nice temperature reservation” function is operating. The start time varies according to the load of room. Since load varies greatly during heating, the operation start time is corrected, so it will vary each day.

INFRARED REMOTE CONTROL

Q12 Timer cannot be set.



A12 Has the clock been set? Timer cannot be set unless the clock has been set.

Q13 The current time display disappears soon.



A13 The current time disappears in approx. 10 seconds. The time set display has priority.

When the current time is set the display flashes for approx 3 minutes.

Q14 The timer has been programmed, but the preset time disappears.



A14 Is the current time past the preset time? When the preset time reaches the current time, it disappears.

OTHERS

Q15 The indoor fan varies among high air flow, low air flow and breeze in the auto fan speed mode. (Heating operation)



A15 This is because the cool wind prevention function is operating, and does not indicate a fault.

The heat exchanger temperature is sensed in the auto speed mode. When the temperature is low, the fan speed varies among high air flow, low air flow and breeze.

Q16 Loud noise from the outdoor unit is heard when operation is started.



A16 When operation is started, the compressor rotation speed goes to maximum to increase the heating or cooling capability, so noise becomes slightly louder. This does not indicate a fault.

Q17 Noise from the outdoor unit occasionally changes.



A17 The compressor rotation speed changes according to the difference between the thermostat set temperature and room temperature. This does not indicate a fault.

Q18 There is a difference between the set temperature and room temperature.



A18 There may be a difference between the set temperature and room temperature because of construction of room, air current, etc. Set the temperature at a comfortable for the space.

Q19 Air does not flow immediately after operation is started.



A19 Preliminary operation is performed for one minute when the power switch on and heating or dehumidifying is set. The operation lamp blinks during this time for heating. This does not indicate a fault.

Inspection instructions



Warning

Note that the 0 V line of the outdoor electrical parts and the primary power circuit of the indoor electrical parts have voltages to ground as illustrated in the right-hand figure.

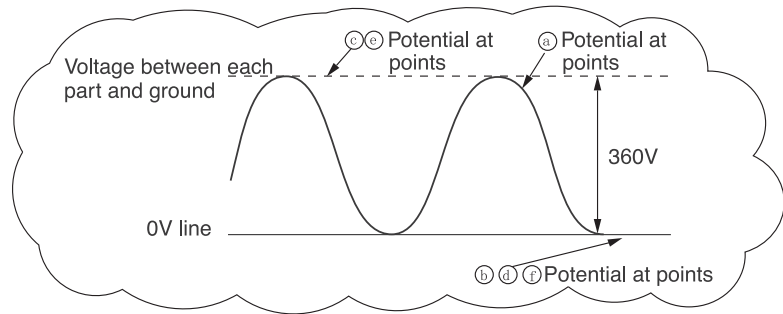
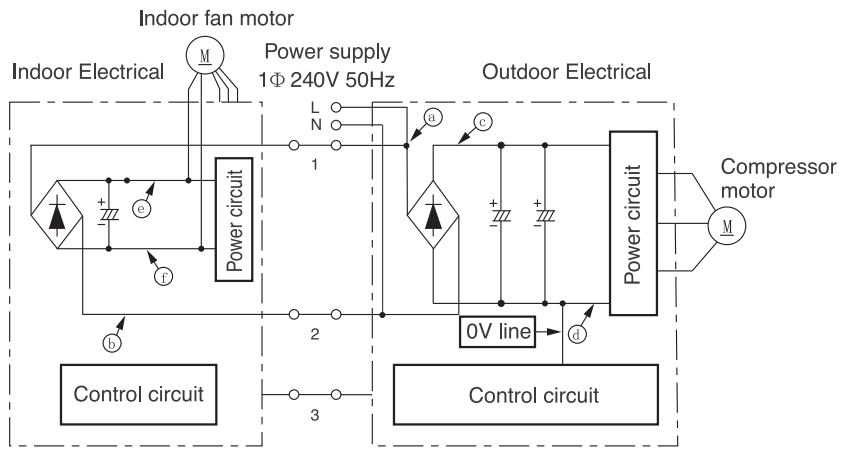

Warning

When conducting a check with an oscilloscope or something similar, do not ground the oscilloscope. Note that the oscilloscope will be subjected to voltages as illustrated in the figure above.

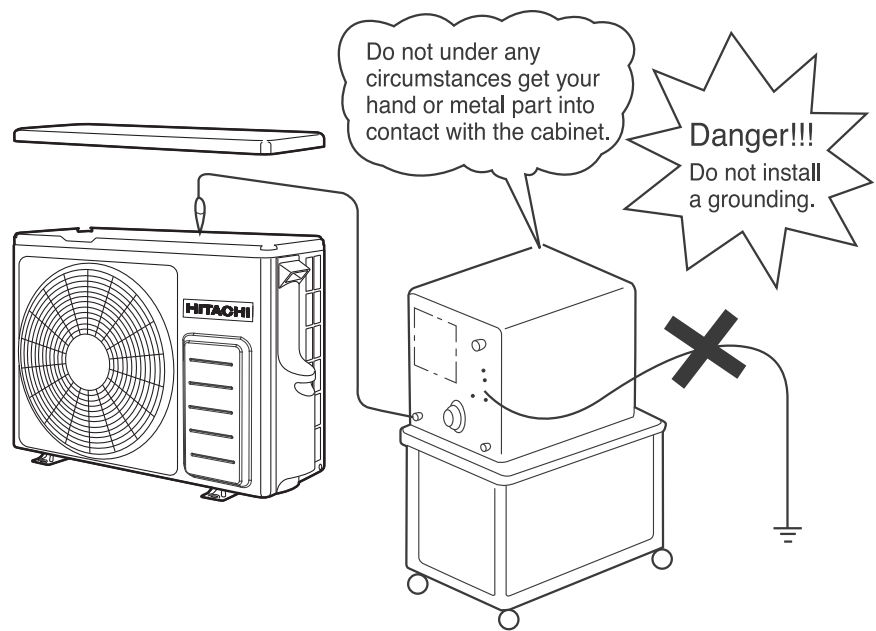

DISCHARGE, PROCEDURE AND POWER SHUT OFF METHOD FOR POWER CIRCUIT



WARNING



Caution

- Voltage of about 360 V is charged between the terminal of smoothing capacitors ($500\mu\text{F} \times 3$).
- During continuity check for each circuit part of the outdoor unit, be sure to discharge the smoothing capacitors.

Discharge Procedure

1. Turn off the power.
2. After power is turned off, wait for 10 minutes or more .Then, remove electrical parts cover and apply soldering iron of 30 to 75 W for 15 seconds or more to TAB7 and TAB8 terminals on the main P.W.B. as shown in the figure below, in order to discharge voltage in smoothing capacitor.

Do not use a soldering iron with transformer: Otherwise, thermal fuse inside transformer will be blown.

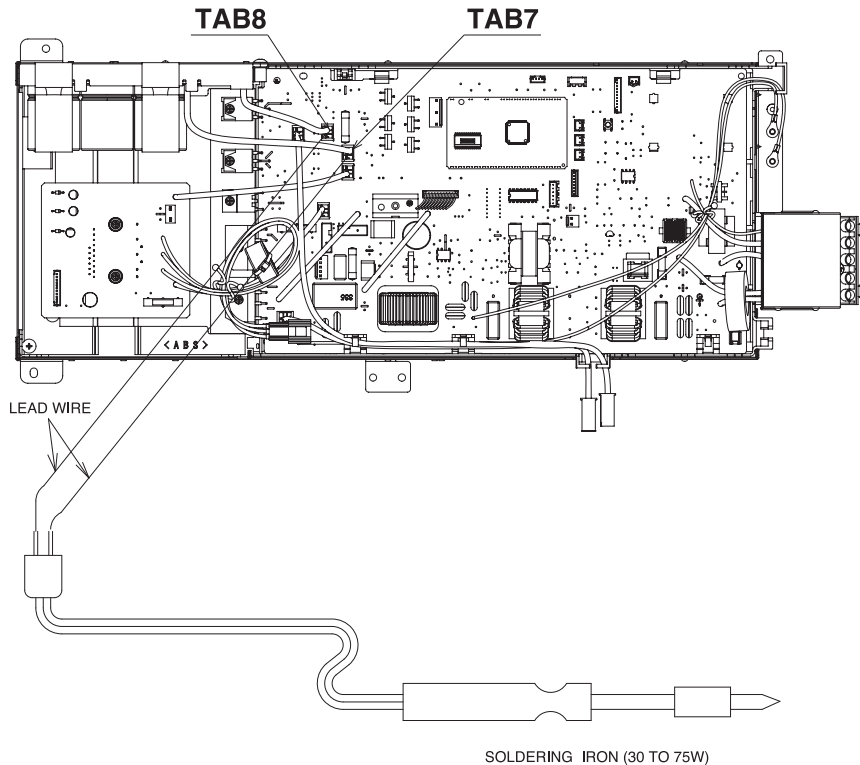

No.	Function	Description	See page
1	Self-diagnosis display [Display on the indoor unit side]	<ul style="list-style-type: none"> • The failure mode detected on the indoor unit side is displayed by blinking of the "timer lamp". • If the outdoor unit side detects a failure, the product will first conduct several operation retry and then blink the "timer lamp" 4 times. There are some failure modes with no lamp display while retry are continued. Then if want to continue further checking based on self-diagnosis method "operation lamp" will blinking. [Failure mode where retry are continued and the indoor unit lamp does not end up giving a error display] • Compressor body temperature rise • Fan stop due to heavy wind • Things with low incident to happen • Supply voltage error 	95
	[Display on the outdoor unit side]	<ul style="list-style-type: none"> • The failure mode detected on the outdoor unit side is displayed by blinking the "LD351" or "LD352". Detecting a failure will stop the outdoor unit and keep blinking the "LD351" or "LD352" until it is restarted. (The communication error will persist until the communication is reestablished.) 	Refer outdoor unit service manual.
2	Self-diagnosis memory	<ul style="list-style-type: none"> • The failure modes detected on the indoor and outdoor unit sides are stored in the nonvolatile memory of the indoor unit and can be read later on. (The memory will remain even after power-off.) • The failure modes detected on the outdoor unit side are written in memory every time any such mode occurs. The failure mode can therefore be detected on the indoor unit side without waiting for the retry frequency to reach the display of the indoor unit lamp. Moreover, the normal self-diagnosis display function which rarely occurs will store and display failure modes that do not end up displaying the indoor unit lamp. (Any such mode may be unable to be stored if indoor or outdoor communications is in a failure.) • The product stores 5 last-stored failure modes. • There is a function for deleting memory. Once you clear the memory and run the product for several days, you can read the failure modes and check them, thereby detecting the less frequent failure phenomena. • Failure modes can be checked by both the blinking of the lamp of the indoor unit and the display of the remote control liquid crystal display. 	96

※The "self-diagnosis function of the communication circuit" available in our conventional models is now incorporated as part of the normal self-diagnosis function. In the case of a failure in the communication circuit, you do not have to conduct a special operation and the operations can be automatically divided into 3 blinking operations and 12 blinking operations of the timer lamp. However, a strong external noise may have resulted in 12 times of blinking.

Self-diagnosis display function (indoor side display)

In case the "timer lamp" (green) or the "operation lamp (yellow) of the indoor unit is blinking, troubleshoot the product while referring to the table below.

1. Method to count the lamp blinking times.

- Blinking will repeat with 2s of interval time.
- Blinking speed will be lit for 0.35s and off for 0.35s.

<Example of 5 times blinking>



2. If you wish to try another operation while the lamp is blinking, press the START/STOP button on the remote control unit twice. The first press will reset the microcomputer while the second will activate the unit. (Except for mode※1)

<Caution>

- There is a failure mode displayed only while the self-diagnosis memory is read. (※2)
Read and check it as necessary.
- An error connection (wrong insertion) of terminal 1 or 2 of connecting cable may go undetected.
- Please confirm operation lamp blinking before proceed to self-diagnosis re-displayed. (※3)
- In case all indication lamp blink
- There is a possibility 100V had been supplied to outdoor unit. Check supply voltage with tester and do repair as below table.

Check Point	Repair or replace part
• Less than 100V supplied.	• Not a failure. Please repair the power supply.
• 220~240V supplied.	• Outdoor electrical part abnormal. Please replace outdoor electrical part.

Blink lamp	Blinks	Check Point	Action	Remark	
Timer Lamp (green)	1	•Reversing valve or related circuit. •Refrigerant cycle abnormal or leak.	•Refer outdoor self-diagnosis. •Check refrigerant cycle.		
	2	•Forced cooling in operation.	•Not a failure.		
	3	•Indoor communication circuit error.	•Replace indoor main PWB.		
	4	•Check failure indication of outdoor unit or failure mode redisplayed.	•Refer table on the right.	※3	
	6	•Abnormal water level detected.	•Check drain pump or drain pan.		
		•Float switch connector bad insertion or wire shorted.	•Securely connect CN22 connector.		
	7	•Drain pump test in operation.	•Not a failure.		
	9	•Connector for room thermistor or heat exchanger thermistor not connect properly or thermistor wire broken or shorted.	•Securely connect CN1 and CN2 connector.		
		•Check terminal board fuse. (Mis-connection of connecting cable might blow the fuse)	•Replace terminal board. •Securely connect the connecting cable.		
	10	•Fan motor connector disconnected.	•Connect securely CN12.		
		•Fan motor lock mechanically.	•Adjust the locking position.		
		•Fan motor broken.	•Replace new fan motor.		
	12	•Connecting cable wrong insert.	•Reconnect cable.		
•Outdoor communication circuit failure.		•Refer outdoor self-diagnosis for detail.			
•Outdoor CN30 forgot to connect.		•Securely connect CN30 connector.			
13	•EEPROM or Microcomputer defect.	•Replace indoor main PWB.	※1		



Blink lamp	Blinks	Check Point	Action	Remark
Operation Lamp (yellow)	Outdoor failure indicate as below when operation lamp blink. Detail shall refer to lamp label attached.			
	2	Peak current cut.		
	3	Abnormal low speed rotation.		
	4	Switching failure.		
	5	Overload lower limit cut.		
	6	Compressor body temperature rise.		※2
	7	Outdoor thermistor abnormal.		
	8	Communication error between micon.		
	9	Indoor unit type mismatch.		
	10	Power voltage error.		※2
	11	Fan stop due to heavy wind.		※2
	12	Fan lock stop.		
	13	EEPROM read error.		
	14	DC voltage abnormal.		
	15	ACT circuit abnormal.		
Totally no operation.	•FU1 3,15A fuse blown		•Replace fuse or other part that causing the fuse blown.	
	•Receiver PWB connector disconnected.		•Securely connect connector CN11A.	
	•Card-key selection [yes] condition.		If not using card-key function, make sure to turned OFF the switch SW501 setting of main PWB.	
		•Indoor PWB defect.	•Replace indoor PWB.	





SELF-DIAGNOSIS MEMORY FUNCTION



Failure modes are stored in the nonvolatile memory of indoor unit and shall be redisplayed by remote controller.

This function is useful in checking the failure modes either during switching OFF the power or restarting the device without checking the number of indication lamp blinking. Remote controller can redisplay up to last 5 failure modes from the memory. However, failure modes which are rarely to occur are also stored in the memory which caused the numbers of failure more than 5. Thus, for some failure modes which are unable to retrieve because of remote controller limit to redisplay only 5 failure modes, it can be found by clearing up the memory first then recheck the memory content again during the visit at the customer place.



< How to redisplay failure diagnosis >

1. Turn the circuit breaker OFF.
2. Set the remote controller to OFF condition, indicated by **OFF** on the display.
3. By pressing  (MODE) button on the remote controller, set to Cooling operation indicated by  (COOL).
4. Turn the circuit breaker ON.
5. Set the room temperature setting on the remote controller to 32°C by pressing the (TEMP \downarrow or \uparrow) button.
6. Set the fan speed with the  (FAN SPEED) button according to the desired failure information. (Refer to the corresponding table below)

Fan Speed	Data
AUTO 	Newest
HI 	Second newest
MED 	Third newest
LOW 	Fourth newest
SILENT 	Oldest

7. While directing the remote controller towards the receiver of the indoor unit, press (TEMP \uparrow) button and  (START/STOP) button simultaneously. (The remote controller perform signal transmission with the device.)
8. The device beeps [Pi-] to indicate that it has just received the signal to redisplay the failure mode.
9. Direct the remote controller towards the receiver of indoor unit (within 2 meters in front of indoor unit) and press the  (INFO) button. Wait for 2 seconds for signal transmission. An error code will be displayed on the remote controller display.

< How to clear the troubleshooting data >

1. Redisplay the troubleshooting status. (See the above procedure.)
2. Turn the circuit breaker OFF.
3. By pressing  (MODE) button on the remote controller, set to Heating operation indicated by  (HEAT).
4. Turn the circuit breaker ON.
5. Set the room temperature setting on the remote controller to 16°C by pressing the (TEMP \downarrow or \uparrow) button.
6. While directing the remote controller towards the receiver of the indoor unit, press (TEMP \downarrow) button and  (START/STOP) button simultaneously. (The remote controller perform signal transmission with the device.)
7. The product beeps for a second [Pi-] to indicate that it has just received the signal. The data has now been cleared.

< How to display error code in case of failure just occurs >

If timer lamp  of the indoor unit blinking and operation stops, please perform below procedures.

1. Direct the remote controller towards the receiver of indoor unit (within 2m in front of the indoor unit) and press  (INFO) button.
2. Wait for 2 seconds for signal transmission.
3. Indication of error code will be shown on the remote controller display for 10 seconds.

For example :

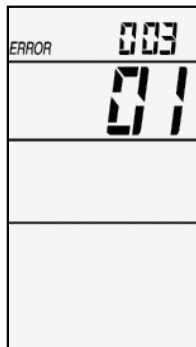
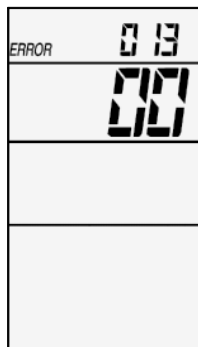

For details information regarding error code, please refer to page 97.

SELF-DIAGNOSIS LIGHTING MODE

MODEL RAC-50NPD AND RAC-60NPD

 DANGER (DC 360V) ● SWITCH OFF MAIN POWER SUPPLY ● DO NOT TOUCH ANY OTHER TO THE OUTDOOR UNIT AT LEAST 10 MINUTES BEFORE START THE SERVICING WORK ● MAKE SURE THE LEVEL DC VOLTAGE BETWEEN TAB7/WHT(+) AND TAB8/BLK(-) IS LESS THAN 10V.			
SELF-DIAGNOSIS LIGHTING MODE ■ LIT ■ BLINKING □ OFF			
LD301 (RED)	NAME	MAIN CHECK POINT	HOW TO REPAIR
■	NORMAL OPERATION	COMPRESSOR OPERATION	NOT MALFUNCTION
■	OVERLOAD OPERATION	COMPRESSOR OPERATION	THIS SHOW AN OVERLOAD, NOT MALFUNCTION
■	BLINKING DURING OVERLOAD	0.3SEC ■■■■■ (■■■■ LIGHTS FOR 2 SEC. AT INTERVAL OF 0.3 SEC.)	
[2] DURING STOP			
□	NORMAL STOP (STOPPED BY INDOOR THERMOSTAT OR MAIN OPERATION OFF)	1. NO NEED TO CHECK	1. NOT ANY MALFUNCTION
■	FAN MODE OPERATION, RESET STOP	1. WAITING FOR COMPRESSOR START 2. OTHER THAN ABOVE	1. NORMAL 2. CHANGE THE P.W.B.S
■	PEAK CURRENT CUT	1. P.W.B.s DEFECTIVE 2. COMPRESSOR ABNORMAL LOAD	1. CHANGE THE P.W.B.S 2. CHECK THE COMPRESSOR
■	ABNORMAL LOW-SPEED ROTATION	1. P.W.B.s DEFECTIVE 2. COMPRESSOR ABNORMAL LOAD	1. CHANGE THE P.W.B.S 2. CHECK THE COMPRESSOR
■	SWITCHING FAILURE	1. COMPRESSOR CONNECTOR OPEN 2. COMPRESSOR ABNORMAL LOAD 3. P.W.B.S DEFECTIVE	1. INSERT THE CONNECTOR 2. CHECK THE COMPRESSOR 3. CHANGE THE P.W.B.S

5 TIMES	OVERLOAD LOWER LIMIT CUT	1. OBSTACLE SUBROUND THE OUTDOOR UNIT 2. OTHER CAUSE	1. REMOVE THE OBSTRUCTION 2. CHECK CYCLE PIPE
6 TIMES	OH THERMISTOR TEMPERATURE RISE	1. DUE TO CONNECTOR OPEN 2. LEAKAGE OF REFRIGERANT 3. OTHER CAUSE	1. INSERT THE CONNECTOR 2. CHECK THE CYCLE PIPE AND RECHARGE THE REFRIGERANT 3. CHANGE THE P.W.B.S
7 TIMES	THERMISTOR ABNORMAL	1. CONNECTOR MISS 2. THERMISTOR WIRE OPEN/SHORT CIRCUIT 3. P.W.B.s DEFECTIVE	1. INSERT PROPERLY 2. CHANGE THE THERMISTOR 3. CHANGE THE P.W.B.S
9 TIMES	COMMUNICATIONS ERROR	1. CONNECTING CABLE MISS CONNECTION 2. CONNECTING CABLE DISCONNECTION 3. P.W.B.s DEFECTIVE	1. CONNECT CONNECTING CABLE PROPERLY 2. CHANGE THE CONNECTING CABLE 3. CHANGE THE P.W.B.S
10 TIMES	ABNORMAL POWER SOURCE	1. REACTOR IS UNCONNECTED 2. ABNORMAL AC INPUT: OUT OF RANGE (230±10%) 3. AC INPUT IS NORMAL	1. CONNECT REACTOR PROPERLY 2. CONNECT TO NORMAL AC POWER SOURCE 3. CHANGE THE P.W.B.S
11 TIMES	OUTDOOR FAN STOP BY STRONG REVERSE WIND	1. OUTDOOR FAN STOP BY STRONG REVERSE WIND	1. IT WILL RE-START AFTER WIND BECOME WEAK
12 TIMES	OUTDOOR FAN LOCK ERROR	1. OUTDOOR FAN STOP BY STRONG REVERSE WIND 2. PROPERLY FAN LOCK 3. OUTDOOR FAN MOTOR LOCK 4. OUTDOOR FAN MOTOR OK	1. IT WILL RE-START AFTER WIND BECOME WEAK 2. REMOVE THE OBSTRUCTION 3. CHANGE THE FAN MOTOR 4. CHANGE THE P.W.B.S
13 TIMES	EEPROM READING ERROR	CHANGE THE P.W.B.S	
14 TIMES	ACTIVE VOLTAGE ABNORMAL	1. P.W.B.S DEFECTIVE 2. ABNORMAL COMPRESSOR LOAD	1. CHANGE THE P.W.B.S 2. CHECK THE COMPRESSOR
15 TIMES	CIRCUIT ABNORMAL	CHANGE THE P.W.B.S	
16 TIMES	HIGH LOAD STOP	1. SERVICE VALVE CLOSE 2. OBSTACLE SUBROUND THE OUTDOOR UNIT 3. CLOGGED FILTER IN INDOOR UNIT	1. CHECK SERVICE VALVE 2. REMOVE THE OBSTRUCTION 3. CHECK FILTER

● EXAMPLE OF BLINKING (6 TIMES) ■■■■■ (■■■■ LIGHTS FOR 0.35 SEC. AT INTERVAL OF 0.25 SEC.)	
--	--

STRUCTURE OF ELECTRICAL

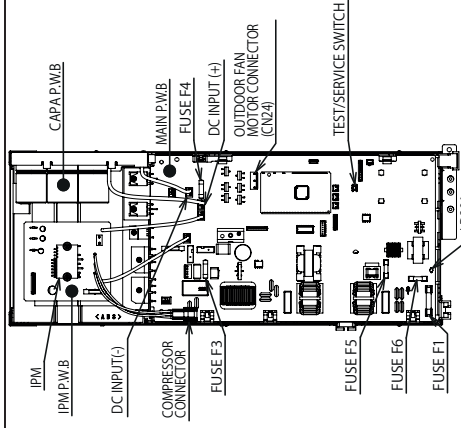

WHEN SELF-DIAGNOSIS BLINKS 2, 3, 4 AND 5 TIMES HAPPEN TO DETERMINE WHETHER COMPRESSOR OR ELECTRICAL UNIT FAULTY, BELOW DIAGNOSIS CAN BE FOLLOWED.

SELF-DIAGNOSIS METHOD

- SWITCH OFF MAIN POWER SUPPLY.
- CONNECT THE CONNECTION OF INDOOR/OUTDOOR TERMINAL 3
- SWITCH ON MAIN POWER SUPPLY.
- WAIT FOR MORE THAN 30 SEC. UNTIL OUTDOOR LD301 BLINKING 9 TIMES.
- KEEP PRESSING THE TEST SWITCH AT OUTDOOR FOR MORE THAN 5 SEC. UNTIL LD301 FAST BLINKS AND THEN RELEASE THE TEST SWITCH.
- SELF-CHECK RESULT WILL DISPLAY AT LD301. REFER TO TABLE 2 FOR THE DETAIL OF THE DIAGNOSIS RESULT.
- SWITCH OFF MAIN POWER SUPPLY ONCE DONE.

TABLE 2 : DURING SELF-DIAGNOSIS COMPLETED	
SELF-DIAGNOSIS LIGHTING MODE	REPAIR METHOD
LD301 (RED)	REPAIR METHOD
1 TIME	1. ELECTRICAL OK
2 TIMES	1. CHANGE P.W.B.s
7 TIMES	1. F. AC VOLTAGE INPUT ABNORMAL (OVER STANDARD VOLTAGE ± 10%) 2. F. COMPRESSOR CONNECTOR CHECK CONNECTOR CONDITION 3. F. COMPRESSOR CONNECTOR CHECK COMPRESSOR CHANGE P.W.B.s
10 TIMES	DC VOLTAGE ABNORMAL
13 TIMES	EEPROM READING ERROR

TABLE 3 : OUTDOOR FAN MOTOR INSPECTION (SELF-DIAGNOSIS)	
1. SWITCH OFF MAIN POWER SUPPLY.	
2. DISCONNECT OUTDOOR FAN MOTOR CONNECTOR FROM CONNECTOR CN24 OF P.W.B MAIN.	
3. ROTATE THE OUTDOOR FAN SHAFT TO CONFIRM THE FAN MOTOR MOVEMENT EITHER NORMAL OR ABNORMAL.	
4. CHECK THE RESISTANCE VALUE BETWEEN PIN TERMINAL SHOULD BE WITHIN 20 TO 50 Ohm.	
* CONNECT BACK THE OUTDOOR FAN CONNECTOR ONCE FINISH DO INSPECTION.	
OTHER INSPECTION: 1. DIAGNOSIS FOR REVERSING VALVE OPERATION ERROR - CHECK REVERSING VALVE WIRE CONNECTION EITHER WIRE BROKEN OR NOT. IF OK, CHECK FUSE F3. IF BROKEN, REPLACE FUSE OR P.W.B.s. 2. DIAGNOSIS FOR COMMUNICATION SIGNAL ERROR OR OUTDOOR NOT FUNCTIONAL. - CHECK WIRING CONNECTION BETWEEN INDOOR AND OUTDOOR.	

Diagnosing Indoor unit, Outdoor unit and Refrigerant cycle.

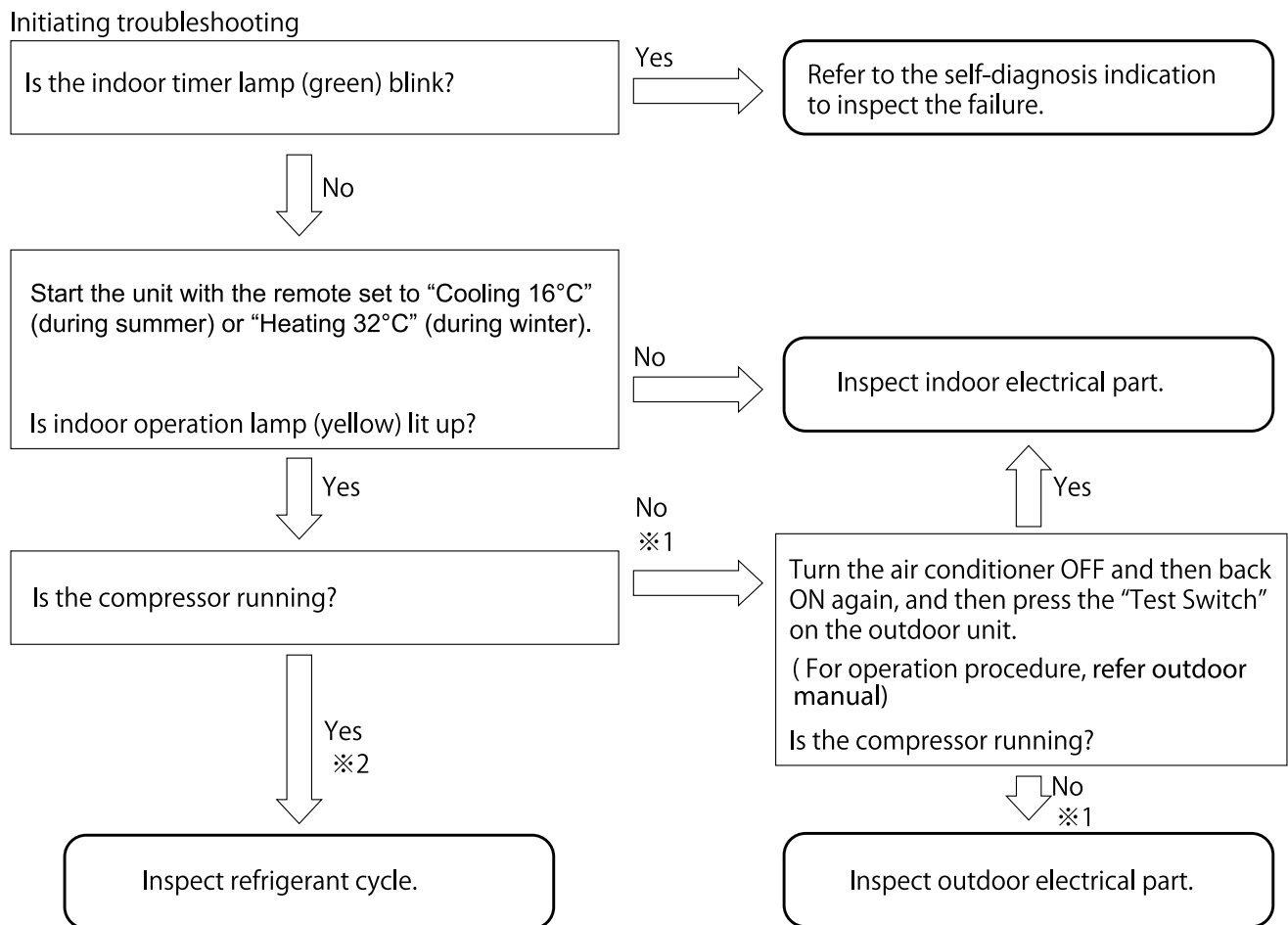

<Failure Diagnosis Using the Self-Diagnosis Memory Function> (Refer page for detail)

- You can use the self-diagnosis memory function to check the failure mode (※1) that occurred on the outdoor unit from the indoor unit.

- Step
1. Clear the troubleshooting data.
 2. Run the unit for several minutes under condition where the compressor runs.
 3. Redisplay and check the data written in the self-diagnosis memory.

- The self-diagnosis memory function can also be used to catch sporadic failure phenomena.

- Step
1. Clear the troubleshooting data.
 2. Have the user use the product as usual until a failure phenomenon occurs.
(The period depends on the incidence of the phenomenon)
 3. At a later date, redisplay and check the data written in the self-diagnosis memory.

- Outdoor self-diagnosis indicator (rising compressor temperature, overload lower limit cut) that are caused by the cooling cycle or the usage environment take a long time to occur after the unit starts running. Further, they are influenced by atmospheric temperature, direct sunlight and operation time, all of which can make it difficult to confirm the failure when a repairman visit. In such case, use the self-diagnosis memory function. (※2)
- The "Fan stopped due to strong wind", "Compressor temperature rise" and "Power voltage error" self-diagnosis indicators on the outdoor unit can be confirmed only by checking the self-diagnosis lamp on the outdoor unit or using the self-diagnosis memory function on the indoor unit.

Checking the indoor unit electrical parts

Introduction

First, check the failure and conditions before moving to a detail diagnosis.

Initiating troubleshooting

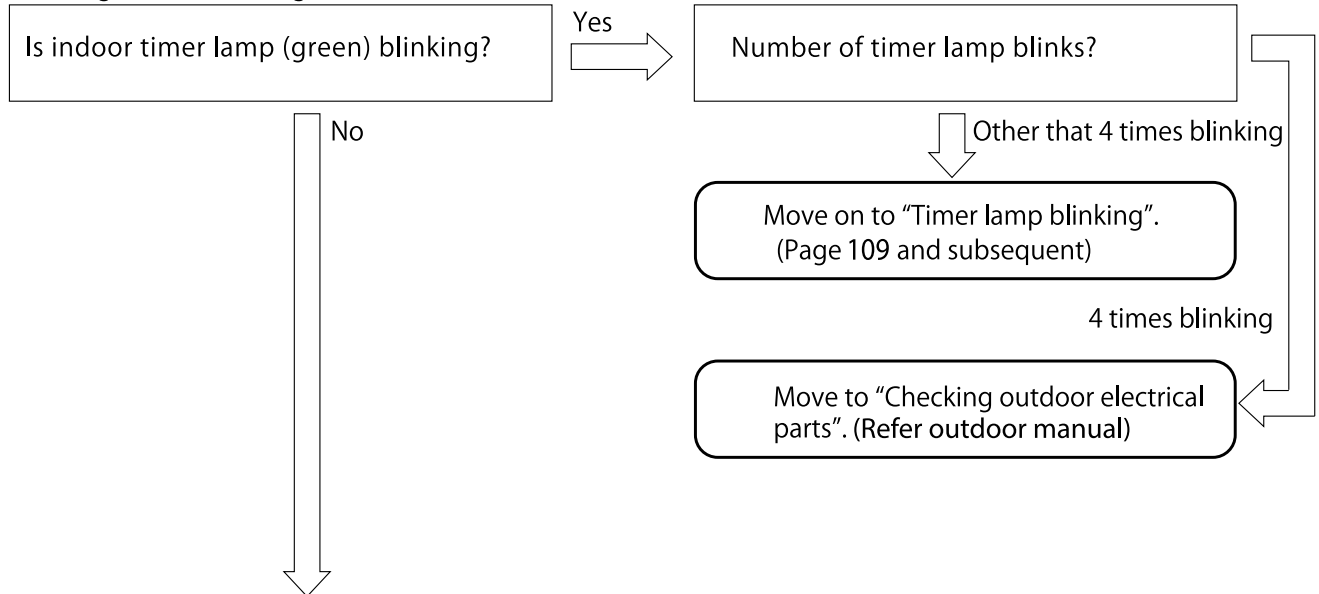

Turn the air conditioner's breaker OFF, wait at least 5 seconds and then turn it ON again. Observe the movement of the horizontal deflector for about 30 seconds.

Check 1 : Does the horizontal deflector move? (Yes / No)

Set the remote control unit to cooling mode, temperature setting 16°C (summer), heating mode, temperature setting 32°C (winter) and operate the product.

Check 2: Can the product received the remote control signal and has the "operation lamp" lit up? (Yes/No)

If you responded "Yes" to Check 2:

Check 3: Is the compressor of the outdoor unit running? (Yes/No)

If you responded "No" to Check 2:

Check 4: Does the indoor "emergency switch" work? (Yes/No)

Check results and next check items

Check 1	Check 2	Check 3	Check 4	Next check item
No	No	—	No	Go on to "Power does not come on". (page 102)
Yes	No	—	Yes	Go on to "The product will not receive the remote control signal". (page 104)
Yes	Yes	No	—	Go on to "The compressor not run". (page 107)

1. Failure : Power does not come on

[Situation] Initialization of the horizontal deflector position and remote control reception do not occur when the power turned ON.

[Suspected failure location]

- Power supply
- Indoor fan motor
- Switching power circuit

[Cautions]

- When going on a service run to address a "Power does not come on" failure, bring along a "3.15A fuse (FU1)" and a "varistor (VA03)".
- Before start repair work, check the voltage coming to the air conditioner's breaker. On rare condition, an abnormal voltage might be supplied by faulty house wiring (240V applied to 100V outlet, neutral line disconnected in single phase 3-wire power supply).
- If an abnormal high voltage is applied to the unit, the 3.15A fuse and the varistor are degraded or damaged, and should be replace.
- If the 3.15A fuse is blown, the cause must be remove first or else the new fuse will blown as well.
- The indoor fan motor is connected to the primary power source. Therefore, a voltage to ground occurs. Take care to avoid electric shock.
- The indoor fan motor uses the same fuse as the control board. If the 3.15A fuse is blown, check the indoor fan motor before turning the power ON.

[Diagnosis flow]

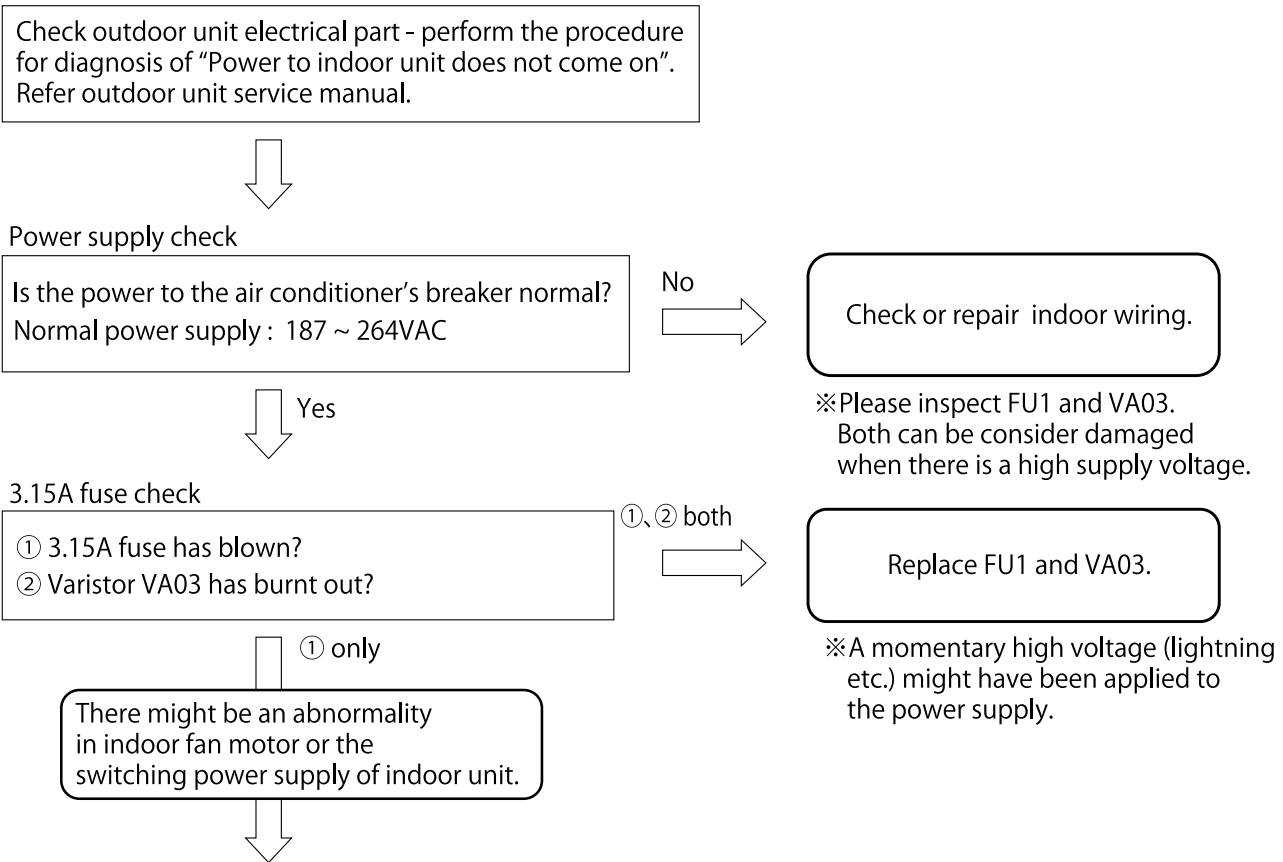

Check indoor fan motor

Turn the fan blade a few times by hand.
Is the spindle tight?
※If the short-circuit occurs, the fan become tight and difficult to turn.
Is there a short-circuit between red and black wire?
※Use a tester to check the insulation between red and black wire of connector CN12 on the indoor PWB.

Yes
→

Replace indoor fan motor and 3.15A fuse.

No
↓

There might be an abnormality in switching power supply of indoor unit.



Check indoor electrical

Replace the 3.15A fuse.
At this time be sure to disconnect the connector CN12 on the indoor PWB side.
Again turn ON power supply, has the 3.15A fuse blown?
※For safety, be sure to close the cover on the indoor unit before performing this work. If you hear any noise, immediately turn the air conditioner's breaker OFF.

No
→

Check all output voltage to search again for problems with the switching power supply. (0V,5V,8.5V,12V)
Check for other abnormalities in the PWB and remove any abnormalities that are found.

Yes
↓

Replace indoor PWB.

2. Failure : Remote control does not receive communication signal

[Situation] No reception or poor reception by the remote control.
(Unit operate normally when using temporary switch)

[Suspected failure location]

- The remote control is damaged, has dead batteries or cannot be reset.
- Remote control receiving unit.
- The connector is loose or disconnected.
- The product is normal (external cause : lighting, remote control of other device, electrical noise, etc.)

[Cautions]

- Even if there are no abnormalities in the product, external factor to the product can cause interference with remote control reception.
- The capacity of the batteries drops in low temperature environment. The voltage of old batteries will drops in particular in the morning and at night in the winter, possibly resulting in reduced remote control range. So, please use new alkaline batteries.

[Diagnosis flow]

Initiating troubleshooting

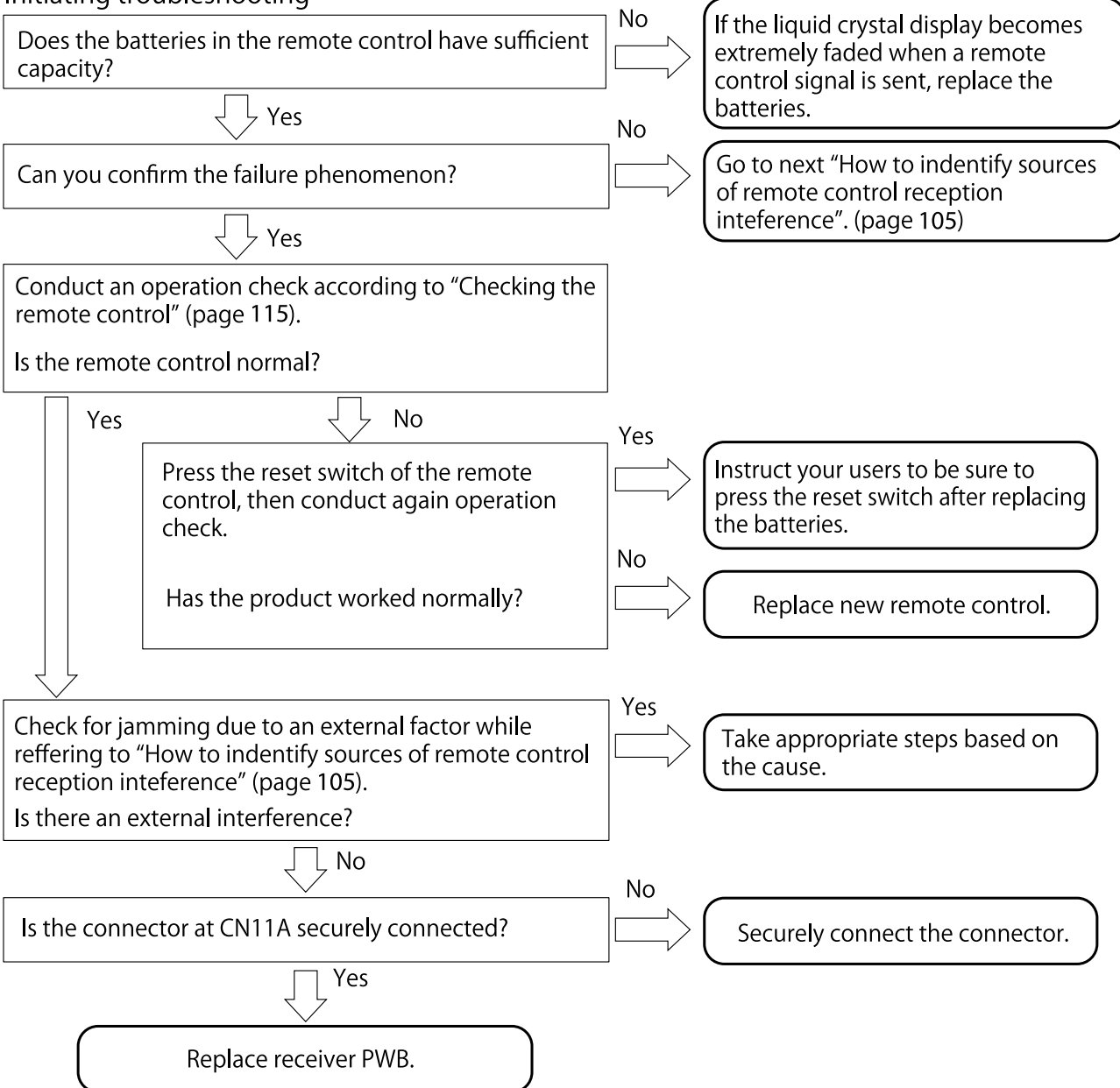

How to identify sources of remote control reception interference

[Situation] The product may become poorly responsive to remote control signals due to external factors even though the product itself is trouble-free.

[Suspected sources of interference] Identify the installation status of the air-conditioner and the indoor and outdoor environments to identify possible causes of the interference.

- Indoor lighting equipment (quantity, type, location)
- Remote control units of other electrical products and equipment
- Is the grounding for the air-conditioner shared with other equipment?
- Are the surroundings of the air-conditioner clear of wireless antenna?
- Is the remote control light-receiving unit protected from direct sunlight?

[Checking and actions]

<p>Effects of lighting equipment (fluorescent lamps)</p>	<p><u>Checking points</u></p> <ul style="list-style-type: none"> • Turn on and off the lighting equipment and check for its effects on the reception of remote control signals. • When cold, the fluorescent lamp tends to emit infrared rays with wavelengths close to those used in remote control. If you cannot detect the phenomenon about which your user is complaining at the time of your visit, such as "the product sometimes fails to receive remote control signals" and "the product fails to receive remote control signals in the morning alone", then turn off the lighting for about 20-30 minutes and wait for the fluorescent lamps to cool down before conducting another check. There are even cases where the product fails to receive remote control signals for 1 to 2 minutes only after the lighting equipment is turned on. • The noise status may vary with the dimming of the lighting equipment. In the case of lighting equipment with a dimmer, therefore, conduct a check with all the light intensities. • If the lighting equipment is the source of the jamming, the remote control light-receiving unit output usually shows a noise waveform as shown in the right-hand figure. In the case of slight jamming, this kind of waveform will not cause practical problems. However, intense degrees of jamming will disable the reception of remote control signals. • When the fluorescent lamp is old and is flickering, it may cause disorders in the reception of remote control signals. <p><u>Actions proposed</u></p> <ol style="list-style-type: none"> 1. Make it hard for light of the lighting equipment to enter the remote control light-receiving unit. <ul style="list-style-type: none"> • Separate the lighting equipment from the indoor unit. • Raise the lighting equipment. • Cover the upper half of the light-receiving panel from its rear side with aluminum tape or black vinyl tape. <p>(This will also affect the reception of remote control signals. Therefore, set the range to be covered with tape to a range that is problem-free in practice, while checking the reception status.)</p> 2. Add an interference filter to the front panel of the remote control light-receiving unit. <ul style="list-style-type: none"> ※ Lighting equipment that produces strong interference exists although rarely. Some problems may therefore be unsolvable by managing the air-conditioner side alone.
<p>Effects of the remote control units of other equipment</p>	<p><u>Checking points</u></p> <ul style="list-style-type: none"> • If, on the remote control unit of a TV or audio equipment, its sound volume key or something similar is left pressed, infrared signals become continuously sent, thereby jamming the reception of remote control signals. • Check how the remote control unit and related components are stored, thereby checking if there is any possibility that a button may be inadvertently left pressed on the remote control unit of other equipment. <p><u>Actions proposed</u></p> <p>If there is any such possibility, give explanations to your users to that effect and instruct them to exercise caution.</p>

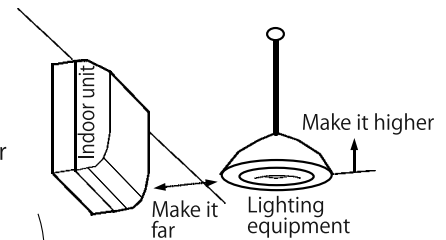
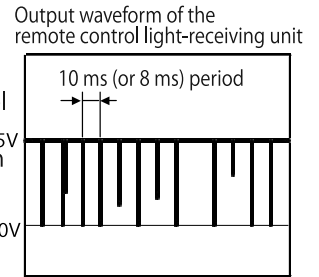

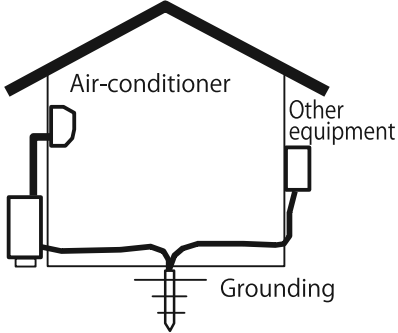
<p>Effects of other electrical products</p>	<p><u>Checking points</u></p> <ul style="list-style-type: none"> • Check the effects of light and power noises coming from other electrical products. • Turn on and off the electrical products, turn off the power and turn on the power, and check their effects on the reception of remote control signals. • For products whose operating states change, check the effects of each state. <p><u>Actions proposed</u></p> <ul style="list-style-type: none"> • Change the location relationship between the air-conditioner and the target products. • Use a different wall outlet for the target products.
<p>Sharing a grounding</p>	<p><u>Checking points</u></p> <ul style="list-style-type: none"> • Check for effects of electrical noises coming into the air-conditioner through grounding wires. • Check if the grounding works is for the air-conditioner alone or shared with other equipment. If there is any equipment that shares it, turn on and off that equipment and detach and reattach the power plugs and examine their effects on the reception of remote control signals. <p><u>Actions proposed</u></p> <ul style="list-style-type: none"> • Establish an independent grounding for the air-conditioner. 
<p>Effects of radio waves</p>	<p><u>Checking points</u></p> <ul style="list-style-type: none"> • Using a wireless transmitter near the air-conditioner may affect the reception of remote control signals. • Have your users try sending signals with a wireless transmitter and examine their effects on the reception of remote control signals. <p><u>Actions proposed</u></p> <ul style="list-style-type: none"> • Add a ferrite core to the power cord and F cable. • Add a ferrite core to the internal wiring of the indoor unit. • Move the wireless antenna.
<p>Effects of direct sunlight</p>	<p><u>Checking points</u></p> <ul style="list-style-type: none"> • Direct sunlight and other intense light make the remote control light-receiving unit less sensitive. • Check for any time zone where the remote control light-receiving unit of the indoor unit is affected by direct sunlight depending on the location of the sun and mirror reflection. <p><u>Actions proposed</u></p> <ul style="list-style-type: none"> • Block the sunlight to protect against direct sunlight.

3. Failure : Compressor does not run

[Situation] Compressor does not run (same condition as thermo off), remote control reception is normal.
The self-diagnosis lamp on the outdoor unit (LD351) blinks once or is off.

[Suspected failure location]

- Indoor room thermistor, Heat exchanger thermistor
- Micro computer surrounding circuit

[Diagnosis flow]

Initiating troubleshooting

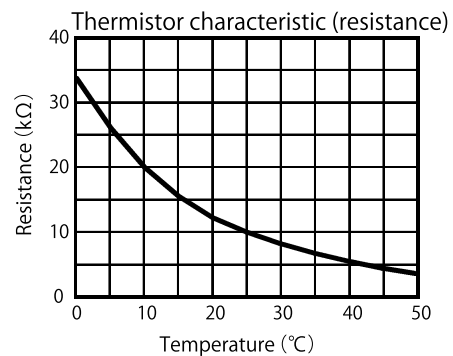
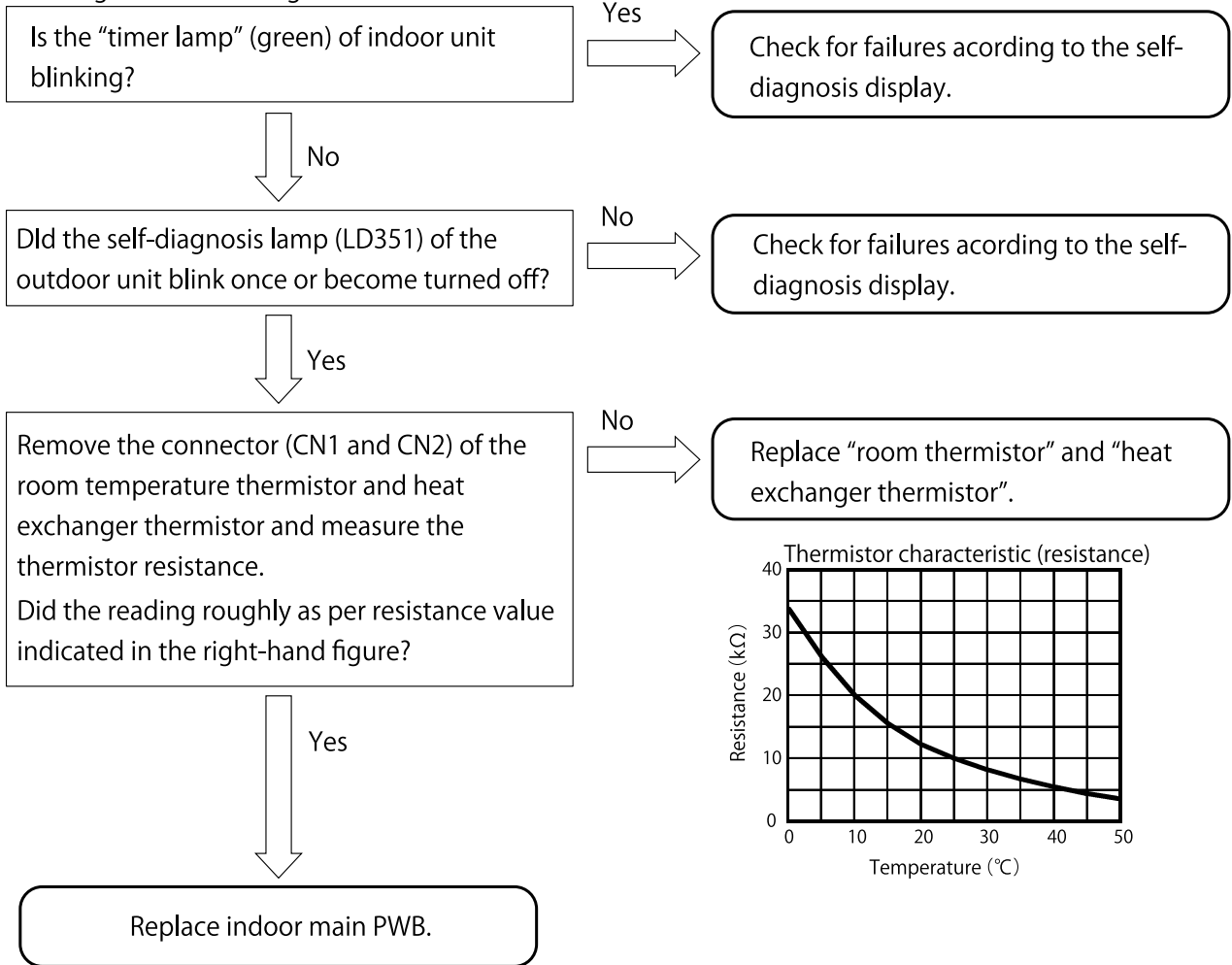

5. Timer lamp blinking : 1 time

[Situation] Timer lamp blinks once and unit operation is not possible.

[Suspected failure location] ● Control circuit failure in outdoor reversing valve, connector disconnected
● Mechanical locking of reversing valve, broken coil wire
● Incorrectly installed indoor unit heat exchanger thermistor (during heating only)
● Clogged cycle (forgot to open service valve, etc.)
● Refrigerant leak

(If most refrigerant is removed in extremely hot (40°C or greater room temperature) or extremely cold (5°C or lower room temperature) conditions, it is possible for this failure mode to occur.)
(Absolutely no cooling or heating)

[Diagnosis flow]

Refer to page "Inspection when timer lamp on indoor unit blink once" of outdoor unit service manual.

6. Timer lamp blinking : 2 times

[Situation] The unit is under forced cooling operation (Not a malfunction).

7. Timer lamp blinking : 3 times

[Situation] Timer lamp blinks 3 times and unit operation is not possible.

[Suspected failure location] ● Indoor communication circuit failure

[Diagnosis flow]

Refer main circuit operation for "Indoor/ outdoor communication circuit (page 85)

10. Timer lamp blinking : 9 times

- [Situation] Timer lamp blinks 9 times and unit operation is not possible.
- [Suspected failure location]
 - Loose connector, wire worn out or short-circuit in room and heat exchanger thermistor
 - Terminal board fuse blown
- [Cautions]
 - Failure detection starts when starting operation with the remote control.
(The failure detection function is not triggered simply by inserting the power plug.)
 - If the terminal board has been replaced because the terminal board temperature fuse blew, check that the dimensions of the insulating coating of the connecting cable inserted in the terminal board are appropriate and that there is no bending in the inserted portion, and then insert it securely into the terminal board.

[Diagnosis flow]

Initiating troubleshooting

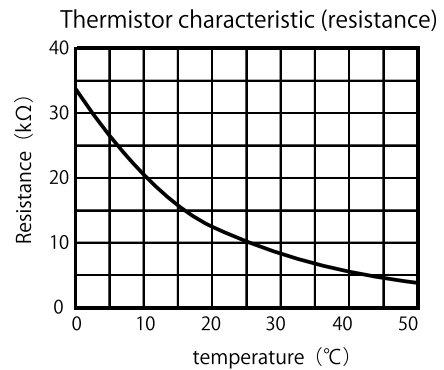
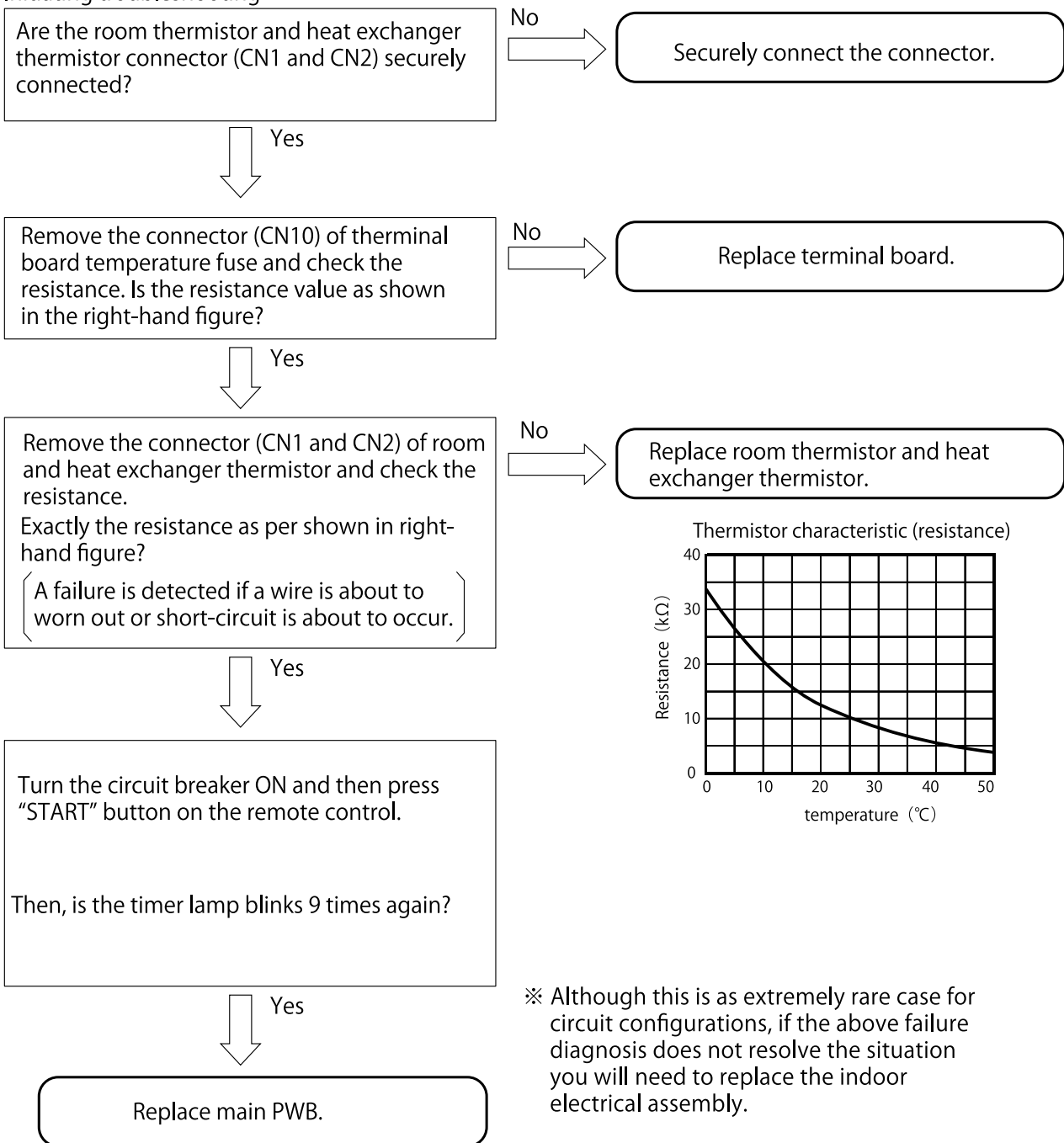

※ Although this is an extremely rare case for circuit configurations, if the above failure diagnosis does not resolve the situation you will need to replace the indoor electrical assembly.

11. Timer lamp blinking : 10 times

[Situation] Timer lamp blinks 10 times and unit operation is not possible.

- [Suspected failure location]
- Fan motor connector disconnected or lead wire worn out
 - Mechanical locking of indoor fan motor or the T-fan.
 - Indoor fan motor failure
 - Indoor fan motor driver circuit failure

[Diagnosis flow]

Make sure to turn OFF the circuit breaker.



T-fan check

Can the fan rotate lightly?
 ※Check or rotate by inertia
 ※Confirm there is no abnormal sound fan is rotating.

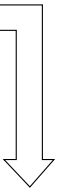
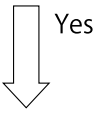

Check work step

Is the fan motor connector (CN12) connection securely?
 Is there any short-circuit?

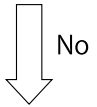

Securely connect.

Are there any factors that interfere with the mechanical rotation?
 Ex.) Foreign matter is mixed in the t-fan.
 Ex.) Adhesion of dust is accumulated.

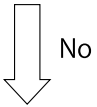
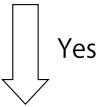

Remove blocking cause.

Replace fan motor.

※Bearing and axis abnormal

Fan motor check

Turn the breaker ON and make the indoor fan motor start to rotate (cooling mode operation or etc.)
 ※Power supply of indoor fan motor is connected to the primary power supply, therefore it is voltage to ground has occurred. Please be careful of electric shock.

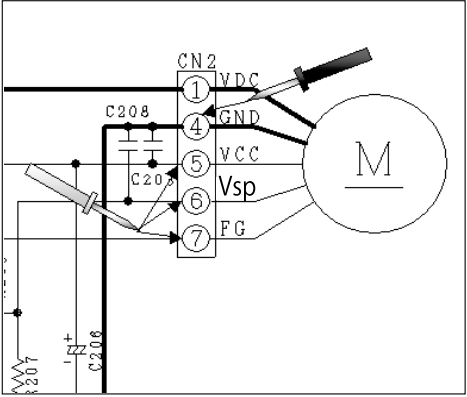

【Inspection location】

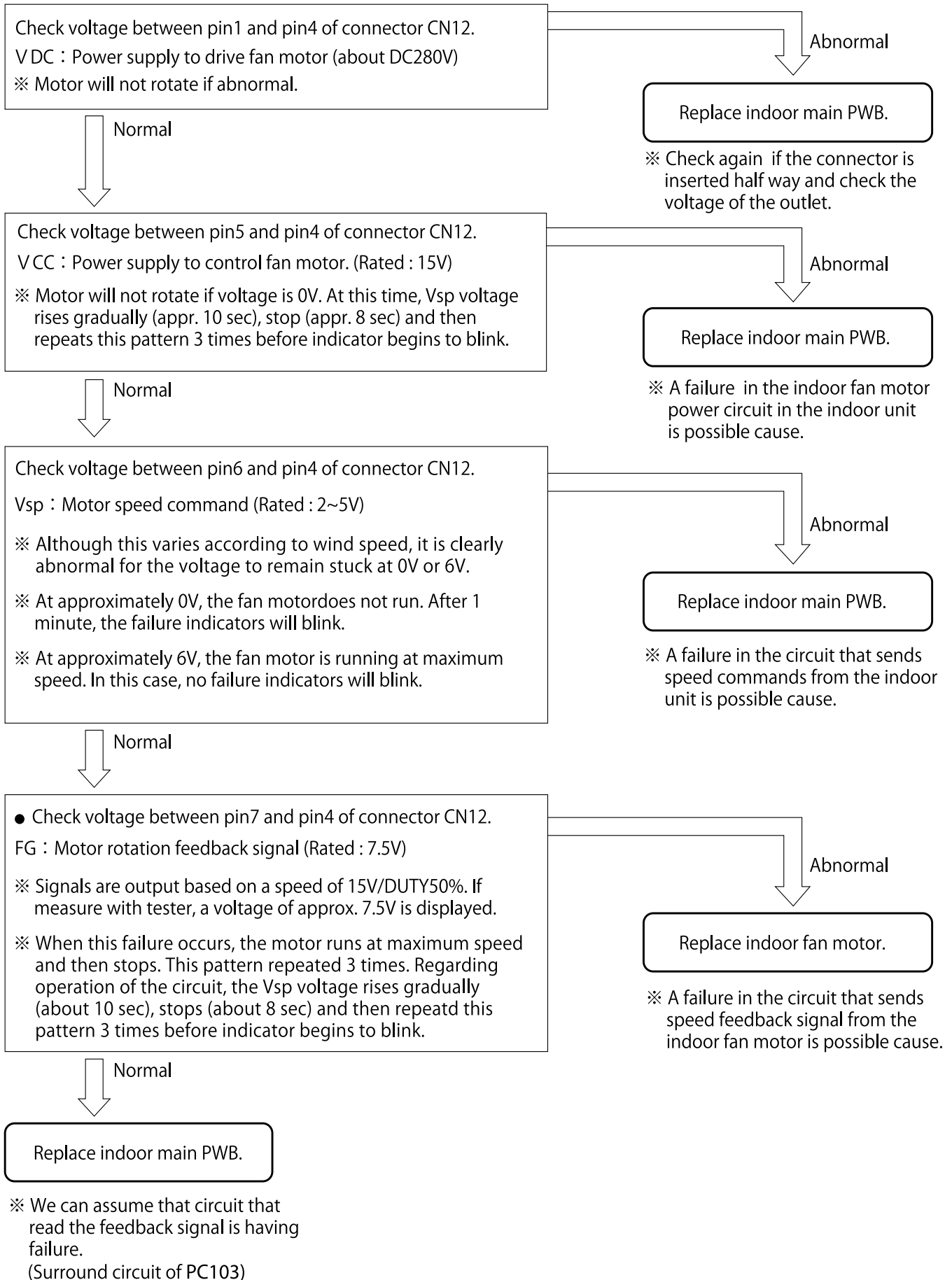

11. Timer lamp blinking :blinking 12 times

[Situation] The timer blinks 12 times and the product will not run.

- [Estimated failure locations]
- Erroneous connection in the indoor-outdoor connection line (connecting cable)
 - Forget to insert back self-check connector at CN27 of outdoor MAIN P.W.B
 - Wire break or poor insertion of the indoor-outdoor connection line (connecting cable)
 - Electrical parts in the outdoor unit (communication circuit, power circuit error)
 - Communication error due to noise in other home electronics
- ※This does not constitute a failure in the air-conditioner

[Cautions] • When lines 1 and 2 of connecting cable are erroneously connected (crossed), the product may not enter self-diagnosis display mode. If the self-diagnosis memory stores data about "timer lamp blinked 12 times", then, just in case, check if the connecting cable is not erroneously connected

[Diagnosis flow]

Initiating troubleshooting

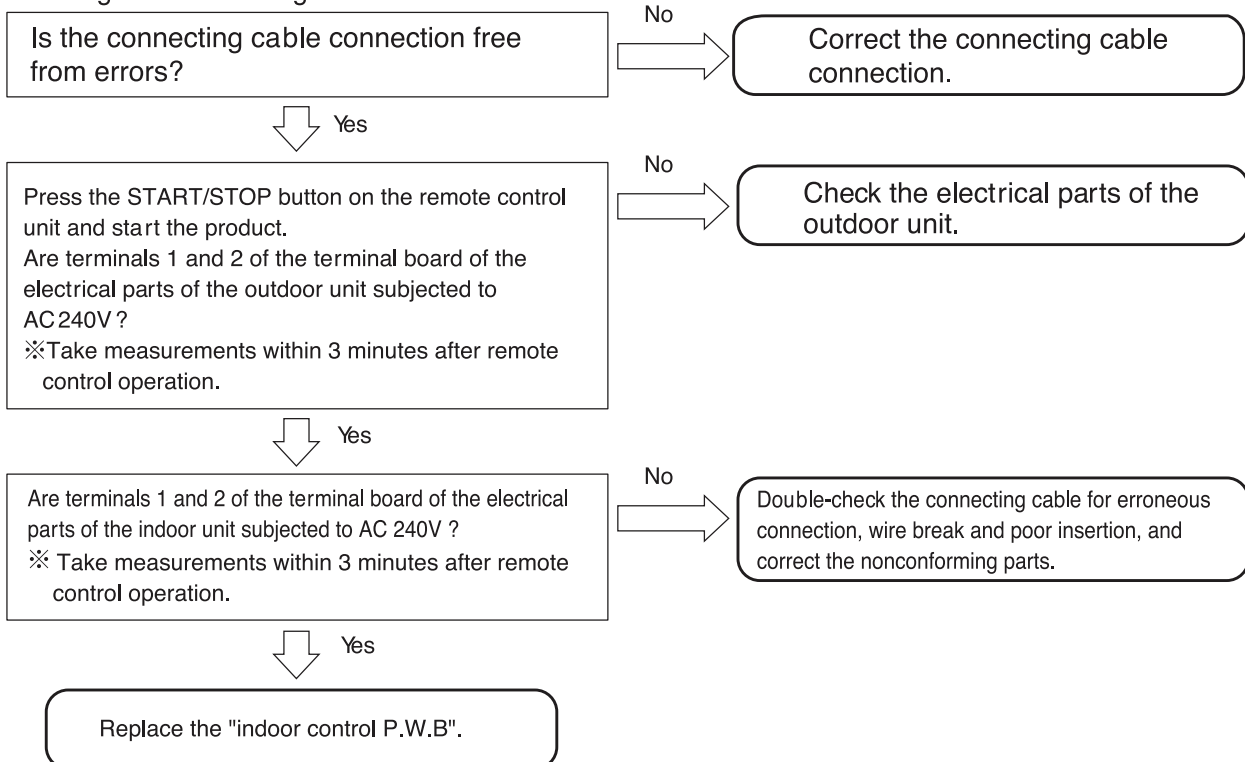

12. Timer lamp blinking :blinking 13 times

[Situation] The timer lamp blinks 13 times and the product will not run.

[Estimated failure location] • EEPROM, microcomputer

[Diagnosis flow]

Replace the "indoor control P.W.B".

Inspecting the wireless remote control

1. Remote transmission check

The remote control for conforming operation of the remote control is describe in RAR-6N5. The method is the same as for checking other remote control.

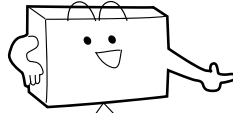

send mark

If the send mark does not appear, check the direction of the poles of the batteries (⊕, ⊖) and if the batteries are dead.

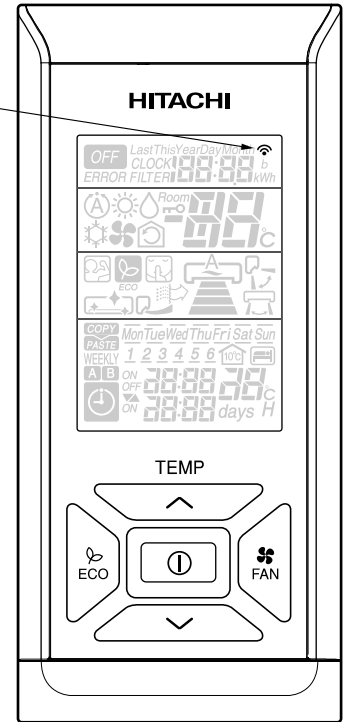

Method of checking remote control

[Checking using PRD checker]

① Select the switch of PRD checker to "Remote checker" side.

② Standing about 3m to 7m away from the PRD checker, aim the remote control toward the sensor and press OFF/START button.

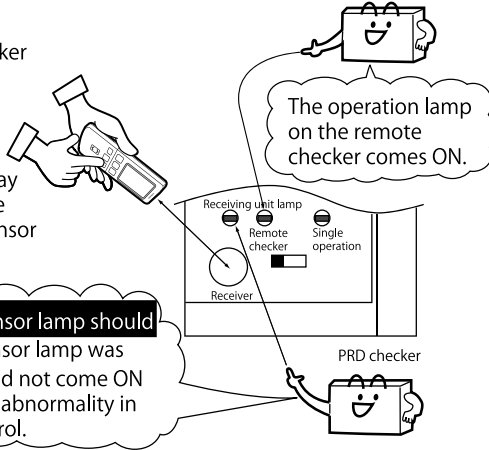

Normally the sensor lamp should lit ON. If the sensor lamp was already ON or did not come ON at all, there is an abnormality in the remote control.

[Checking using mobile phone's camera]

※ Some cameras do not clearly show infrared energy.

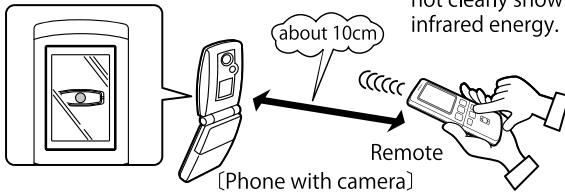

① Hold the mobile phone so that the transmission area of the remote control can be viewed with the camera.
② On the camera screen, a flash should appear in the transmission area of the remote control when buttons are pressed.

[Checking using digital camera]

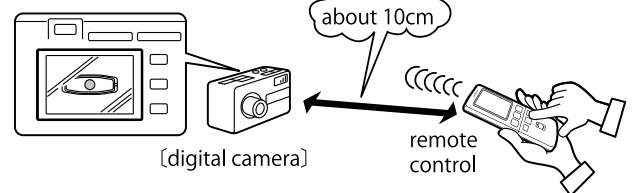

① Hold the camera so that the transmission area of the remote control can be viewed with the camera.
② On the camera screen, a flash should appear in the transmission area of the remote control when buttons are pressed.

[Checking using AM Radio]

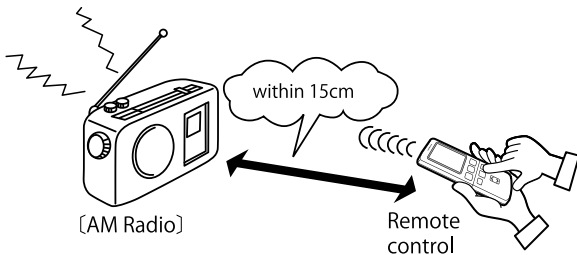

It is normal when noise (bii-bii- sound) should be heard when buttons on the remote control are pressed.

[Checking using remote checker card]

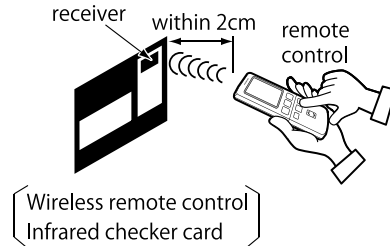

Its consider normal if the receiver turned to orange color when any button was press on the remote control.

Normal

Abnormal

Check for the external causes of interference to the indoor unit and remote control reception.

Check the operation once again. If the remote control does not operate normally, replace it.

Part description	Part no.
PRD Checker	RSC-PRD1006

Checking the electrical parts of outdoor unit

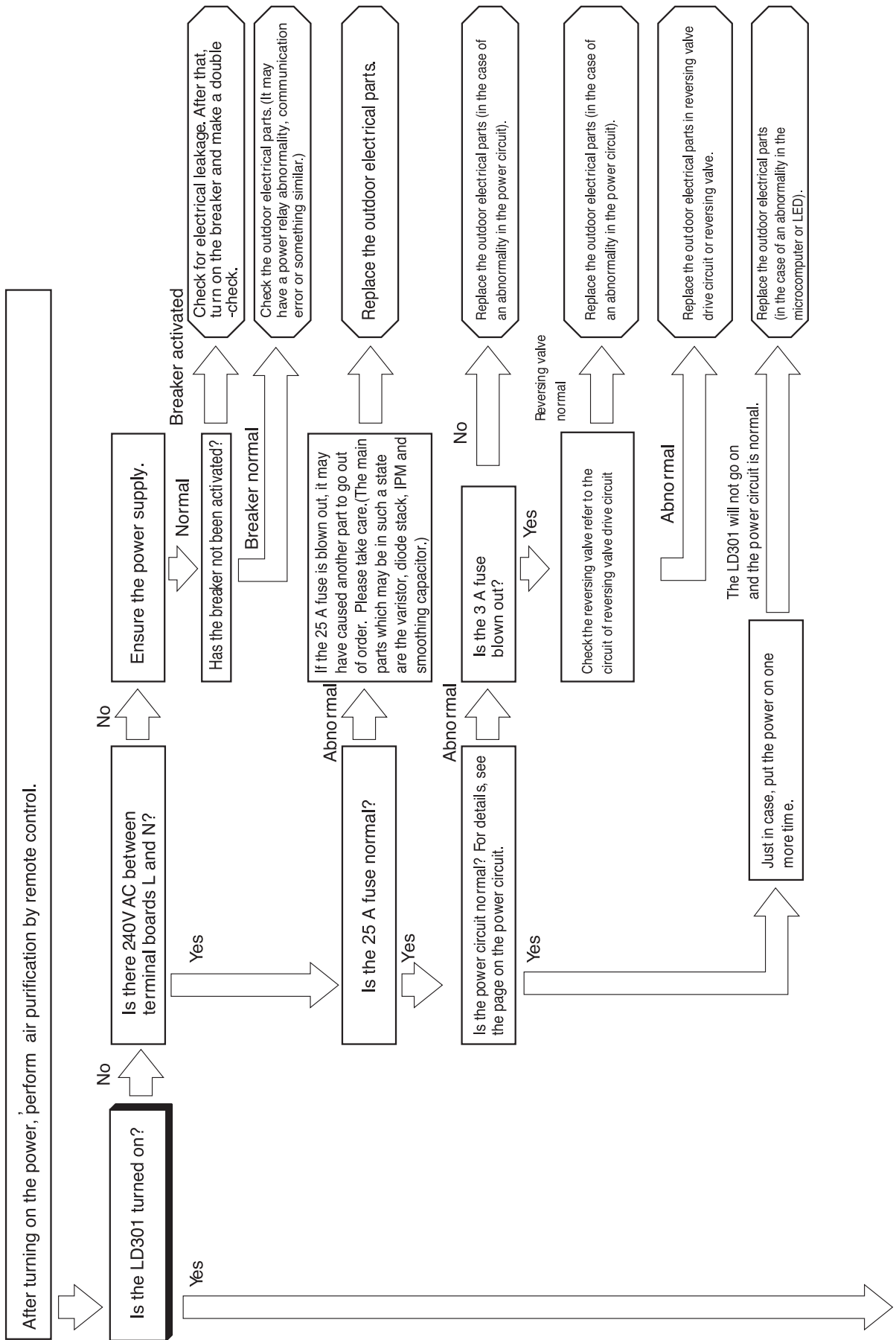

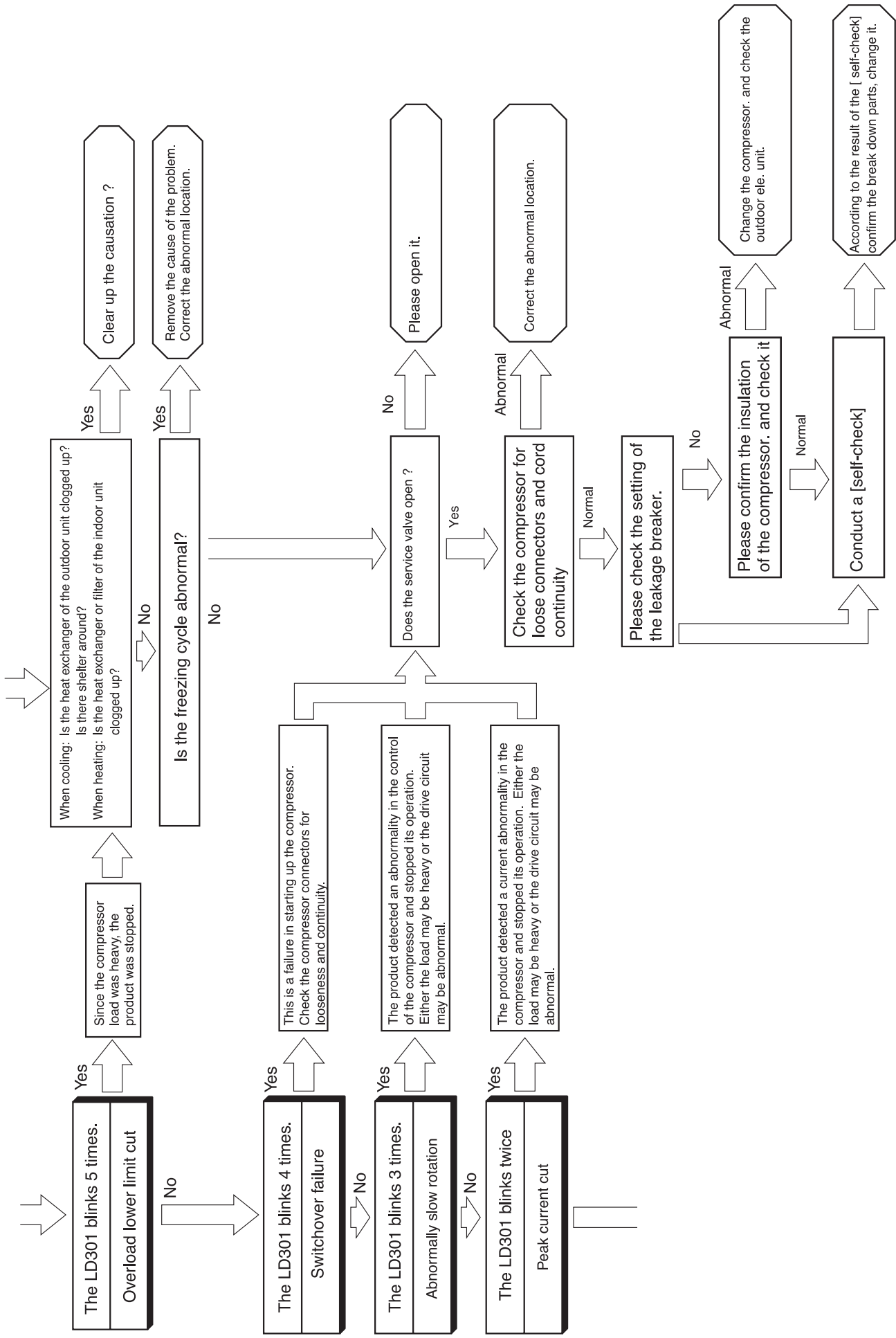

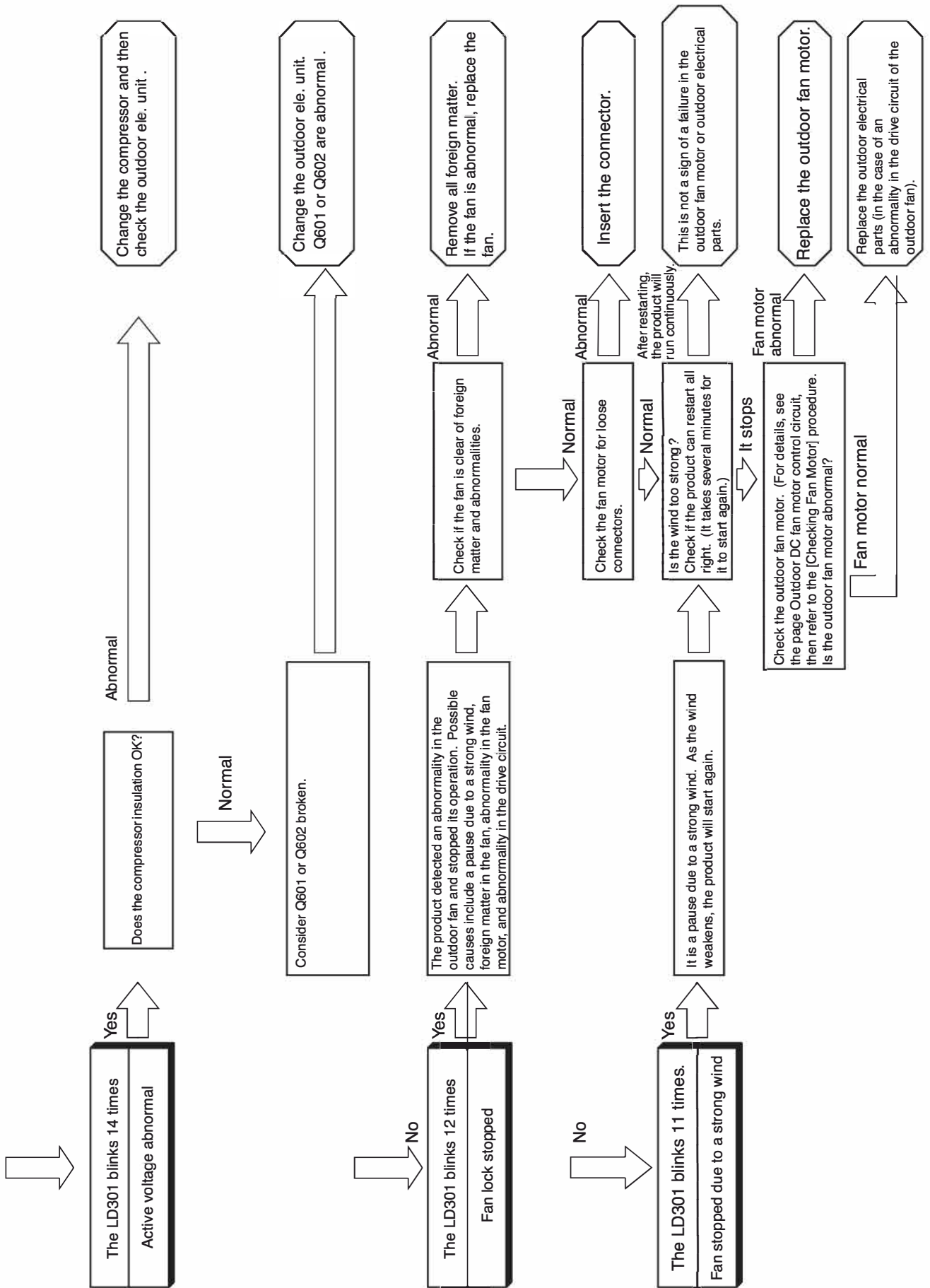

HOW TO CHANGE THE SHIFT VALUE SETTING TEMPERATURE USING WIRELESS REMOTE CONTROLLER

The shift value setting temperature for Cooling and Heating mode operation can be change using remote controller. (This procedure shall be implemented strictly by service personnel only.)

(For initial shift value temperature setting for Cooling mode (SHIFTC) and Heating operation mode (SHIFTW) : Please refer to page 67)

PROCEDURES

1. While pressing and holding (START/STOP) button and (ON) button, press [RESET] button on the same. Release [RESET] button only and make sure that all marks on the remote controller display are indicated, then release the (START/STOP) button and [ON] button. Remote controller now enters "Shift Value Change Mode".

2. Press the (MODE) selector button so that the display indicates (FAN) mode.

3. Press the (START/STOP) button and FAN operation will be started.

4. Set the FAN SPEED with the (FAN SPEED) button according to the following FAN speed setting in order to choose the desired operation mode that is required for shift value setting temperature modification.

- To change the shift value for COOLING mode operation, select either (HIGH) or (MED) FAN SPEED.
- To change the shift value for HEATING mode operation, select either (LOW) or (SILENT) FAN SPEED.

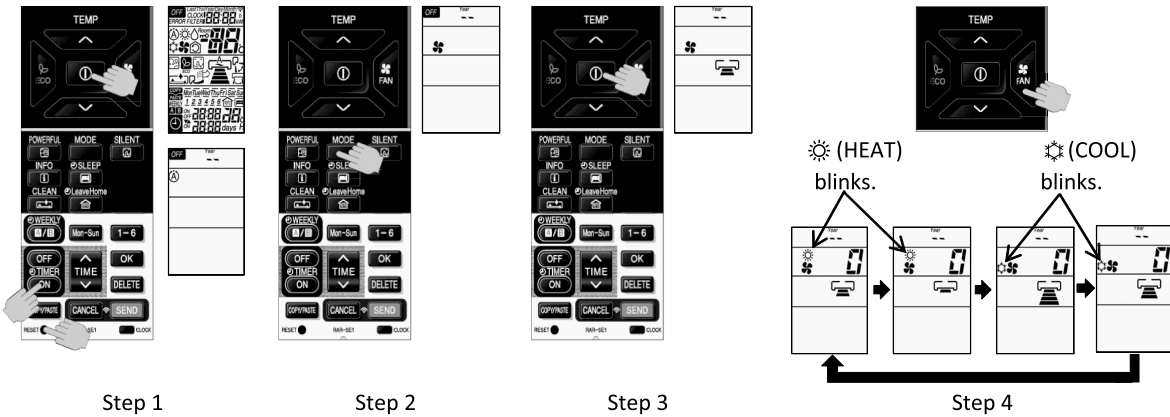

5. Press the (TEMP \vee or \wedge) button to change the shift value. (The shift value changed with device beep sound.)

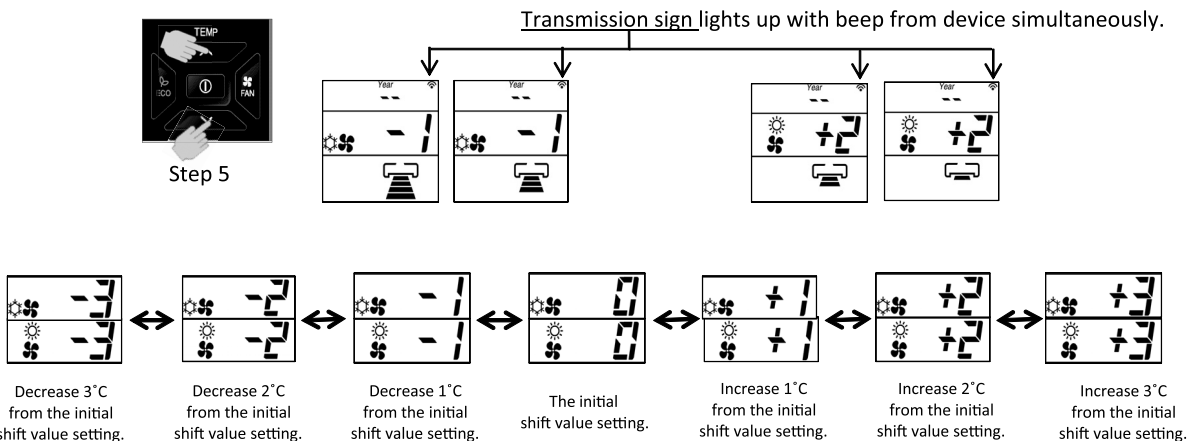

NOTE :

- (1) The displayed shift value, (HEAT) and (COOL) symbol on the remote controller display will be disappear after 10 seconds.
- (2) The changed shift value will remain unchanged after turned off the power.
- (3) If "0" is displayed on the remote controller display, it indicates the shift value is now at the initial setting.

HOW TO CHANGE THE SHIFT VALUE for SETTING TEMPERATURE USING WIRED REMOTE CONTROLLER

Shift value for COOLING and HEATING mode operation can be changed using wired remote controller.

(This procedure shall be strictly carried out by service personnel).

(For initial shift value temperature setting for Cooling mode (SHIFTC) and Heating operation mode (SHIFTW):
Please refer to page 67)

PROCEDURE

1. While pressing the **ON/OFF** and **ON TIMER** button, press and release the **RESET** button once.
All icon will be displayed on the LCD screen and shortly disappear.
Initial cursor will be at AUTO mode. After about 5 sec, cursor will shift and blink continuously at HEATING mode. Release hold of **ON/OFF** and **ON TIMER** button.
The remote is now in **SHIFT VALUE CHANGE MODE**.

2. Press **ON/OFF** button. Operation LED will ON. Cursor will stop blinking. Unit will operate in FAN mode.

3. Set the FAN SPEED with the **FAN SPEED** button according to the following FAN speed setting in order to choose the desired operation mode that is required for shift value setting temperature modification.

- To change the shift value of COOLING mode operation, select either **HIGH** or **MED** FAN SPEED.
- To change the shift value of HEATING mode operation, select either **LOW** or **SILENT** FAN SPEED.

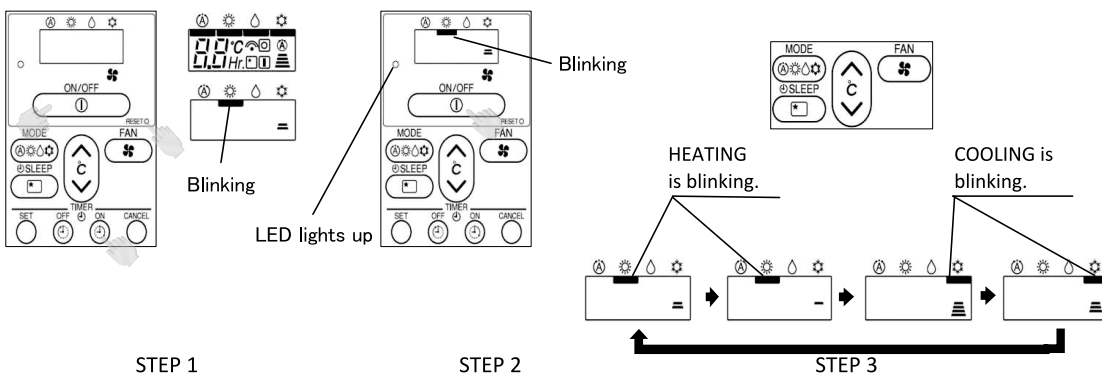

4. Press the **TEMP V or Λ** button to change the shift value.

Please check the transmission sign.

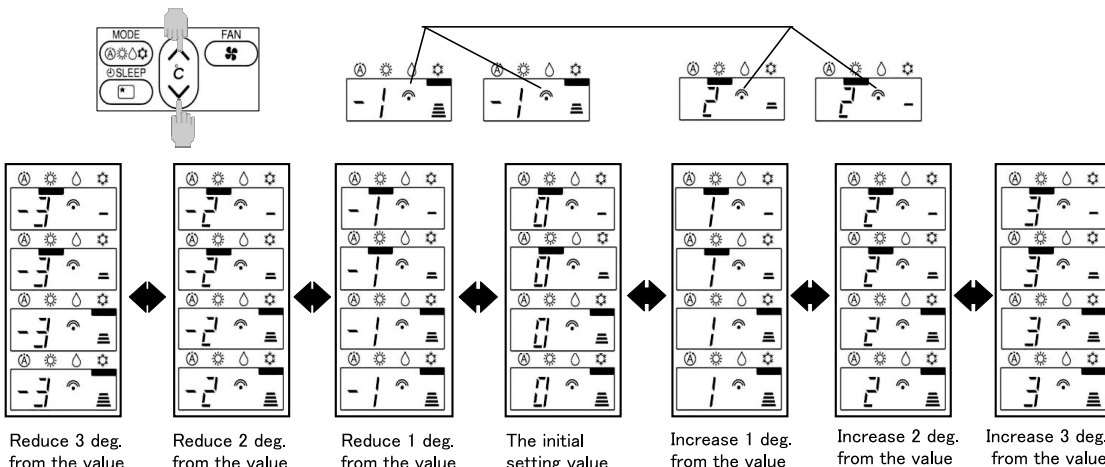

5. Press the **ON/OFF** button to end "Shift value change mode".

NOTE :

1. Shift value is everytime temperature button is pressed. Maximum 7 shift values only. (-3°C to +3°C)
2. Changed shift value remain even after power supply is switched off.
3. By default the Shift value is set at "0°C" on the remote display. This indicates the unit is set to initial setting.

SETTING THE PREVENTION OF MUTUAL INTERFERENCE FOR REMOTE CONTROLLER

(Applicable for Remote controller model : RAR-5E1, RAR-5E2, RAR-5E3, RAR-5E4, RAR-5E5, RAR-6N1, RAR-6N2, RAR-6N3, RAR-6N4 and RAR-6N5)

Case : 2 sets of indoor units installed near to each other.

If both indoor units can receive the same remote controller signal, please set the remote controller as below. (This setting will change the signal address of each remote controller.)

Initial remote controller signal address setting is **A**.

This procedure change the remote controller signal address from **A** to **B**.

1. The circuit breaker for the other unit shall be OFF.



2. Slide the remote controller cover to take it off.
3. While directing the remote controller towards the receiver of the indoor unit, press **1-6** button, **ON TIMER** button and **RESET** button simultaneously. (The remote controller perform signal transmission with the device.)

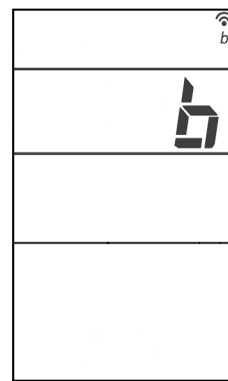
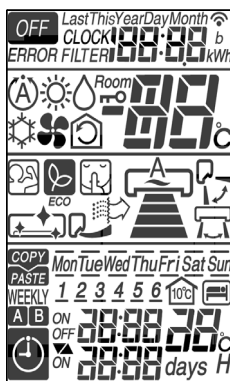
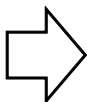
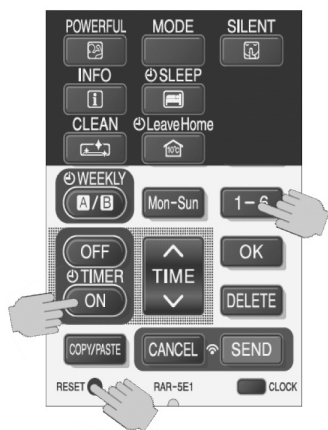

Signal transmission : From A to B



4. The indoor unit beeps [Pip] to indicate that it has just received the signal from remote controller.



5. Please check the usability of each set of indoor unit using its own remote controller.

Note : If indoor unit still not receive the correct signal from the correct remote controller, setting shall be made again.
By setting again for the 2nd time, the signal address will change from **B** to **A**. Then, if repeat again for the 3rd time, the remote controller signal address will change from **A** to **B**.

Signal transmission : From B to A

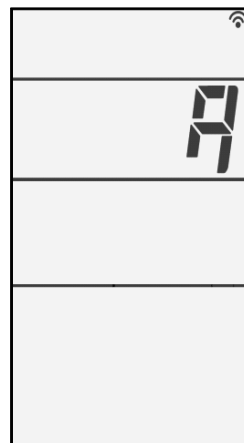







OPERATION MODE LOCK SETTING

If Dip switch position is set at "Heating mode only" or "Cooling mode only" as mentioned on page 91, it is required to set the remote controller into operation mode lock setting. Without setting the remote controller, it will caused unmatch signal transmission between indoor unit and remote controller.





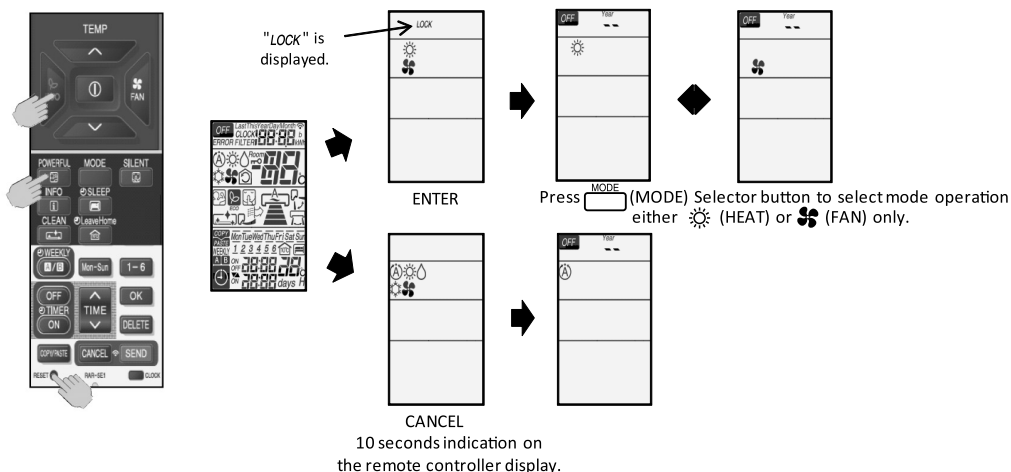

PROCEDURE

1. Heating operation mode lock setting

- (a) While pressing and holding  (ECO) button and  (POWERFUL) button, press  (RESET) button on the same time. Release  (RESET) button only and make sure that all marks on the remote controller display are indicated, then release the  (ECO) button and  (POWERFUL) button. Remote controller now enters "Heating operation mode lock".
- (b) To cancel the "Heating operation mode lock", repeat the above procedure (1(a)).





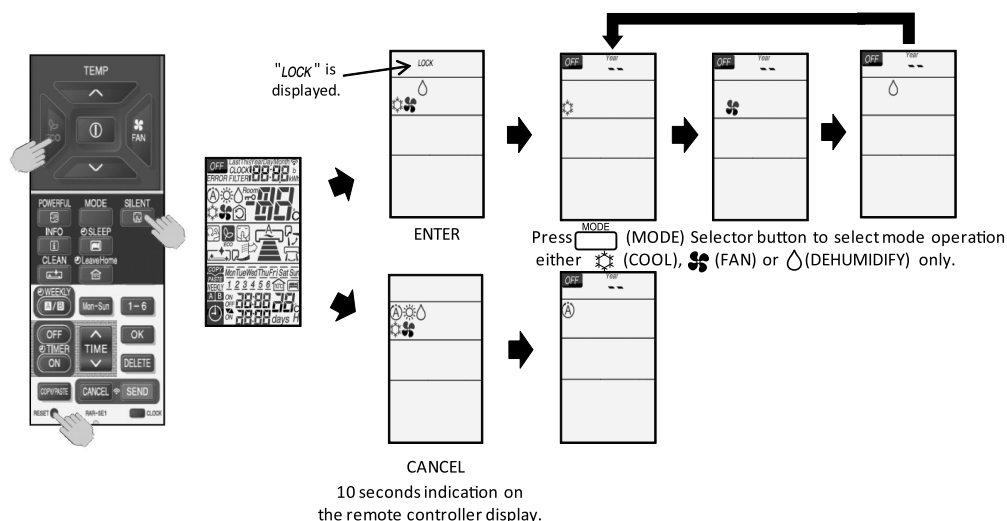

2. Cooling operation mode lock setting

- (a) While pressing and holding  (ECO) button and  (SILENT) button, press  (RESET) button on the same time. Release  (RESET) button only and make sure that all marks on the remote controller display are indicated, then release the  (ECO) button and  (SILENT) button. Remote controller now enters "Cooling operation mode lock".
- (b) To cancel the "Cooling operation mode lock", repeat the above procedure (2(a)).











NOTE :

- (1) The indication of " LOCK " and (" , " , " , or " ) mode operation symbol on the remote controller display will disappear after 10 seconds and it will enter to OFF condition indicated by **OFF** on the display.
- (2) The OPERATION MODE LOCK setting will remain in the remote controller memory even though the remote controller is ran out of battery.



DISPLAY OPERATION MODE SETTING

For operating indoor unit independently (without outdoor unit connection), remote controller has to be set according to below procedures before send the signal to the indoor unit. New communication format between indoor and outdoor is required to communicate with outdoor unit.

PROCEDURE

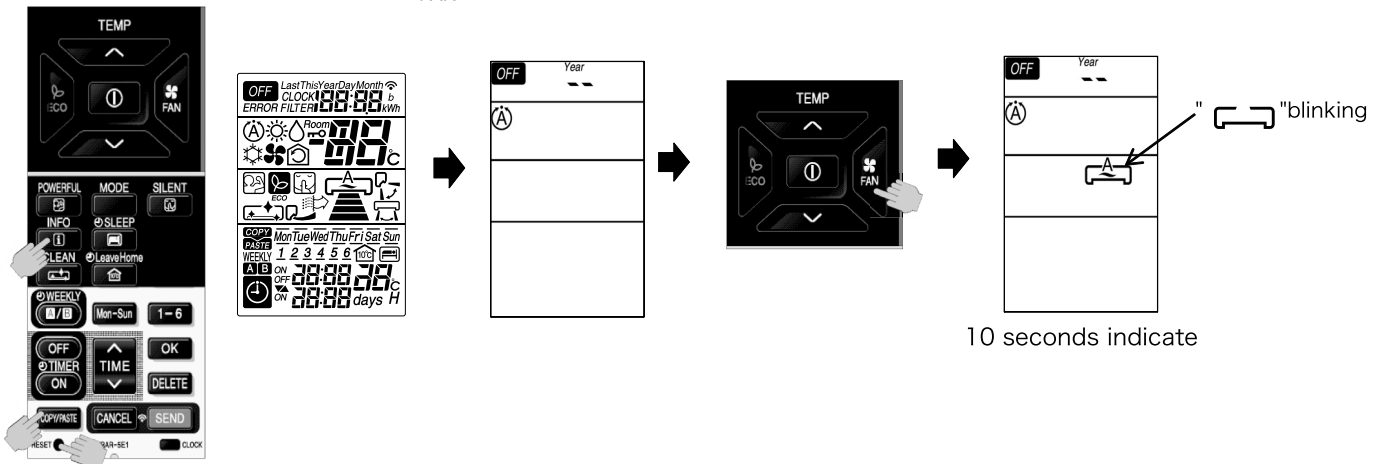
- While pressing and holding  (INFO) button and  (COPY/PASTE) button, press  (RESET) button on the same time. Release  (RESET) button only and make sure that all marks on the LCD display are indicated, then release the  (INFO) button and  (COPY/PASTE) button. Remote controller now enters "DISPLAY OPERATION MODE" for the indoor unit to run independently. Please ensure that when pressing  (FAN) button, "" will blinking.



- Press the  (MODE) selector button to choose the desired operation mode.
- Press  (START/STOP) button.
Then, the indoor unit will starts to operate independently accoring the selected operation mode.

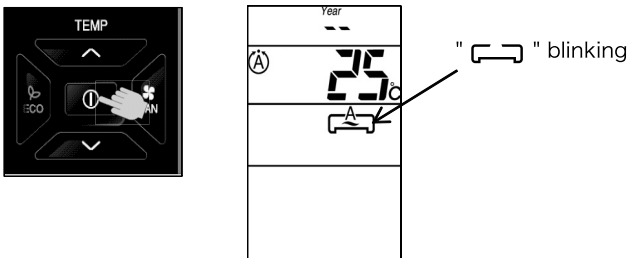

NOTE :

- (1) During "DISPLAY OPERATION MODE", " blinks on LCD of remote controller.
- (2) When operation stops, "DISPLAY OPERATION MODE" is canceled.

CHECKING THE REFRIGERATING CYCLE

(JUDGING BETWEEN GAS LEAKAGE AND COMPRESSOR DEFECTIVE)

1. Troubleshooting procedure (No operation, No heating, No cooling)

Connect U,V,W phase leads to the power module again and operate the air conditioner.

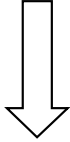

Is the self-diagnosis lamp mode as shown on the right?

Lighting mode Self-diagnosis lamp	Blinks 2 times	Blinks 3 times	Blinks 4 times	Blinks 5 times	Blinks 6 times	Blinks 8 times
LD301						
Time until the lamp lights	Approx. 10 seconds			Approx. 10 seconds	Within Approx. 30 seconds	Approx. 10 seconds
Possible malfunctioning part	Compressor				Gas leakage	Compressor

Blinking off

YES

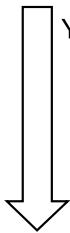

Stop to operate and check the gas pressure in balancing mode.

Normal
(0.39-0.98 MPaG)
(4-10 kg/cm²G)

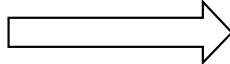

● Checking the system power module



Gas leaking
(less than 4kg/cm²G)
(less than 0.39 MPaG)

Gas leaks.
Repair and seal refrigerant.

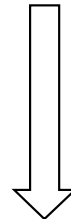

When the self-diagnosis lamp lights in the same condition as above.

The compressor is defective. Replace it and seal refrigerant.
(If the compressor checker for an inverter type air conditioner is available, re-check using it.)

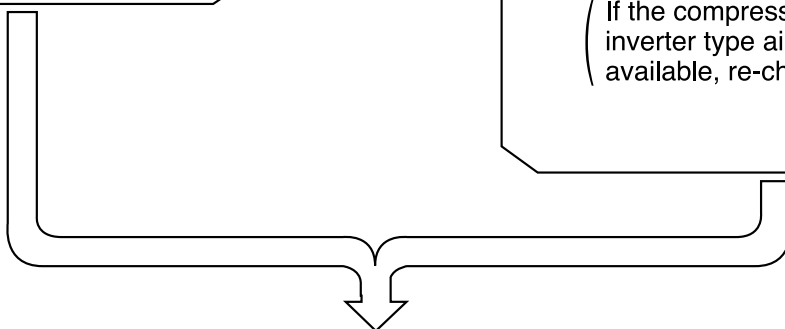

Perform a final check of operation.

Forced cooling operation

The cooling operation can be forcibly performed for collecting refrigerant and inspecting failures. Do not perform the forced cooling operation continuously for long hours, because the compressor continues to be in operational status, regardless of room temperature.

<How to start the operation>

- The operation of the unit should be stopped.
- Press and hold the "Temporary operation SW" shown in the right figure for 5 sec.

<How to stop the operation>

- Press and hold the "Temporary operation SW" again.
- Or stop the operation using the remote controller.

※During the forced cooling operation, the "Timer indicator" blinks twice.

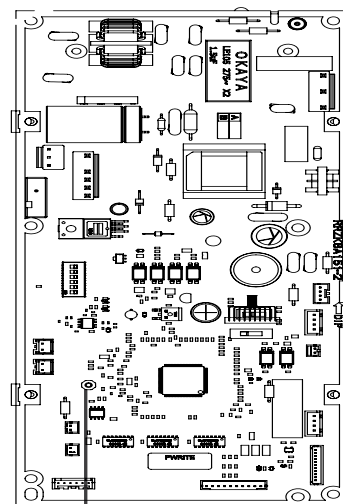

Temporary operation switch

When performing the forced cooling operation, turn the power on once. If you press and hold the switch for 5 sec or longer, the forced cooling operation starts. To stop the forced cooling operation, press the switch once again or stop the operation using the remote controller.

How to run the product with the outdoor unit test switch

If the indoor electrical parts is out of order and if you wish to run the outdoor unit

1. Remove the connection of indoor/outdoor connecting cable Terminal 3.
2. Turn on the outdoor terminal boards L and N (230 V AC).
3. Confirm that the "LD301" blinks once from the terminal side of the outdoor unit. Afterwards (when about 30 sec elapses after the power turns on), confirm that the "LD301" changes to blinking 9 times (communication error).
4. When the "LD301" is blinks 9 times, if you press the test switch, the "LD301" lights up.

If you release your finger from the test switch within 1 sec to 5 sec after pressing the switch, the forced cooling operation starts.

※(If you press the test switch for 5 sec or longer, the self-check diagnosis starts. In this case, turn the power off and start the procedure from once again.)

※(For the initialization of the expansion valve, it may take 1 min until the operation starts.)

5. When you press the test switch again for 1 sec or longer, the unit stops the operation.

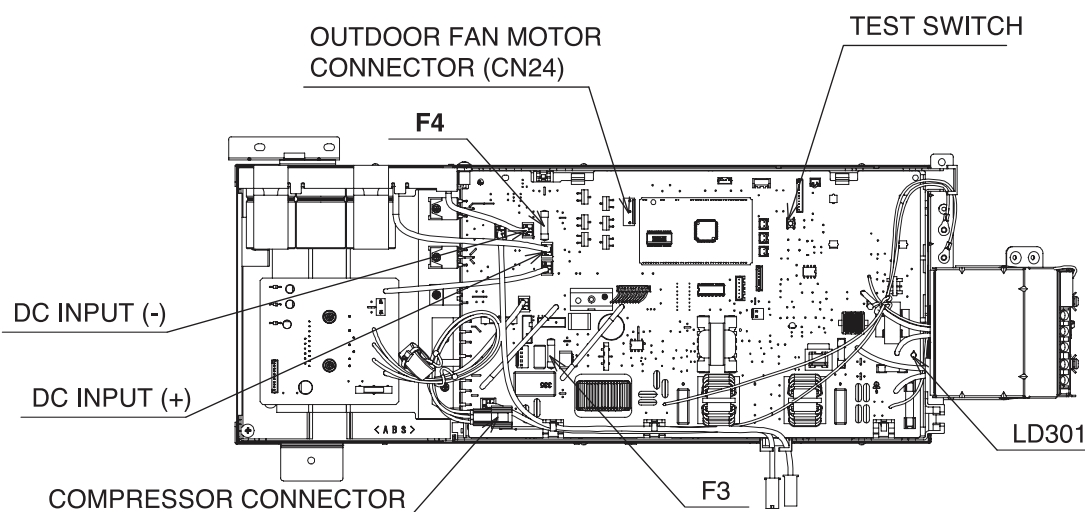

※Cautions

1. Applying power directly to the outdoor unit will cause a rush current to stress the outdoor unit. Therefore, if the indoor unit is not out of order, do not use the method described in 2).
2. Before making the connections, be sure to turn off the breaker.
3. Do not under any circumstances run the product for more than 5 minutes.
4. Doing work with the compressor connector removed will cause the LD301 to blink 4 times. It will not start.
5. For another test run, turn off the breaker and turn it back on. (The test switch is accepted only once after power-on. After operation by remote control, it is not accepted.)
6. When the operation with the test switch is over, turn off the breaker and set the connectors back.

HOW TO OPERATE THE OUTDOOR UNIT INDEPENDENTLY

1. Connect the large dia. pipe side and small dia. pipe side service valve using a pipe.

Connect the small diameter service valve and the large diameter service valve using the reducing union and copper pipe as shown on the right.

Charge refrigerant of 300g after vacuuming (※1)

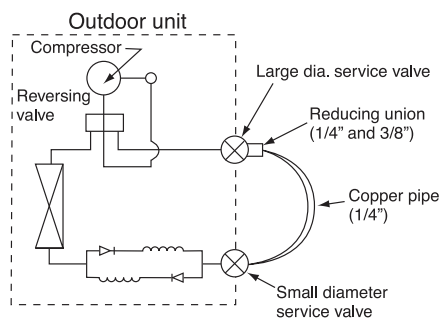

Parts to be prepared

- (1) Reducing union
1/4" (6.35 mm)
3/8" (9.52 mm)
- (2) Copper pipe (1/4" and 3/8")

Do not operate for more than 5 minutes

The operation method is the same as "How to operate using the connector to servicing the outdoor unit".

※1 The charging amount of 300g is equivalent to the load in normal operation.

SUMMARY OF TROUBLESHOOTING METHOD FOR OUTDOOR UNIT

MODEL : RAC-50NPD AND RAC-60NPD

Checking the IPM IC of IPM P.W.B.

- 1) Power off the unit.
 - 2) Disconnect compressor wire connector between compressor to IPM P.W.B.
 - 3) Check the diode value between below point :-
 - a) Terminal U, V, W (+ side of multimeter probe) to Terminal P (WHT wire) (- side of multimeter probe). It shall be around 0.40 to 0.43.
 - b) Terminal N (BLK wire) (+ side of multimeter probe) to Terminal U, V, W (- side of multimeter probe) It shall be around 0.40 to 0.43.
- **During normal running, DC voltage between below point are:-
- a) Terminal P & Terminal N shall be around 320V
 - b) Terminal U, V, W (+ side of multimeter probe) to Terminal N (- side of multimeter probe) shall be around 160V.

Checking the fan motor winding.

- 1) Power off the unit.
 - 2) Disconnect fan motor wire from CN24 of MAIN P.W.B.
 - 3) Check the resistance value between RED, WHT, BLK wire of fan motor. It shall be around 20Ω to 50Ω.
- **During normal running, DC voltage between RED, WHT, BLK wire of fan motor (+ side of multimeter probe) to Terminal N (R741 leg) (- side of multimeter probe) shall be around 160V.

Test Run

- 1) Remove Terminal 3 connection.
- 2) Power ON the unit and wait for 30 seconds.
- 3) Press and hold test switch for 5 seconds.

Checking the expansion valve winding.

- 1) Power off the unit.
- 2) Disconnect the expansion valve from CN15 of MAIN P.W.B.
- 3) Check the resistance value between wire of expansion valve as below:-
 - a) WHT to BRN
 - b) ORN to BRN
 - c) YEL to RED
 - d) BLU to RED
 It shall be around 46Ω ± 3.7Ω.

Checking the compressor motor winding.

- 1) Power off the unit.
- 2) Disconnect compressor wire connector between compressor to IPM P.W.B.
- 3) Check the resistance value between WHT, YEL, RED wire of compressor wire. It shall be same on all terminals between 1Ω to 3Ω.

Checking the reactor winding.

- 1) Power off the unit.
 - 2) Disconnect YEL and BRN wire at TAB3 and TAB4 from MAIN P.W.B.
 - 3) Check the resistance value between YEL & BRN wire of reactor. It shall be around 0.01Ω to 0.1Ω.
- ** During normal running, DC voltage between TAB 3 and TAB4 shall be 17V to 20V.

Checking all the fuse continuity. There are 5 fuses inside the MAIN P.W.B.

- 1) Power off the unit.
- 2) Check the continuity of below fuse:
 - a) F1 (25A) b) F5 (3.15A)
 - c) F6 (3.15A) d) F3 (3A)
 - e) F4 (2A)

Checking the power source.

- 1) Power ON the unit.
- 2) Check the AC voltage from power source between terminal L and N. It shall be around 240 ± 10 V

Checking the connection of 1, 2, 3 terminal to the indoor.

- 1) Power ON the unit.
- 2) After around 1 minute, check the AC voltage between terminal as below table.

Connection condition	Voltage value between terminal			Outdoor LD301 indication
	1 to 2	2 to 3	1 to 3	
All connection OK	240V	around 0.3V	240V	Off or 1 time blink
Terminal 1 no connection	240V	0.1-0.4V	240V	9 times blink
Terminal 2 no connection	240V	100 - 120V	120-140V	9 times blink
Terminal 3 no connection	240V	0.1-0.4V	240V	9 times blink

Checking the OH thermistor.

- 1) Power off the unit.
- 2) Disconnect the thermistor wire from CN8 of MAIN P.W.B.
- 3) Check the resistance value between the wire of thermistor. It shall be around 25kΩ ± 5kΩ.

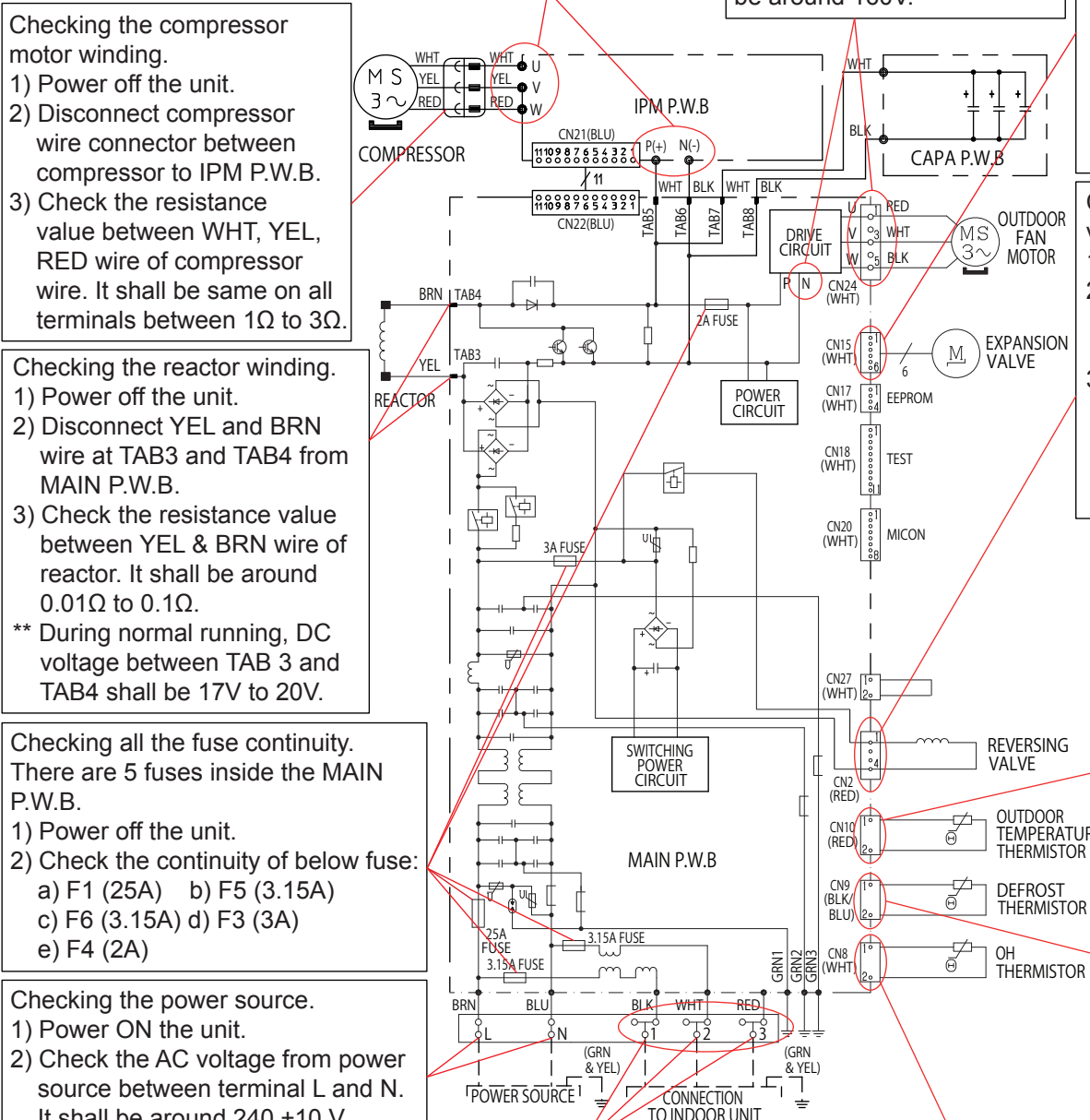

Checking the reversing valve winding.

- 1) Power off the unit.
- 2) Disconnect the reversing valve wire from CN2 of MAIN P.W.B.
- 3) Check the resistance value between the wire of reversing valve. It shall be around 1.9kΩ.

Checking the outdoor temperature thermistor.

- 1) Power off the unit.
- 2) Disconnect the thermistor wire from CN10 of MAIN P.W.B.
- 3) Check the resistance value between the wire of thermistor. It shall be around 1.7kΩ ± 0.3kΩ.

Checking the defrost thermistor.

- 1) Power off the unit.
- 2) Disconnect the thermistor wire from CN9 of MAIN P.W.B.
- 3) Check the resistance value between the wire of thermistor. It shall be around 1.7kΩ ± 0.3kΩ.

PARTS LIST AND DIAGRAM

INDOOR UNIT

MODEL : RAD-50PPD & RAD-60PPD

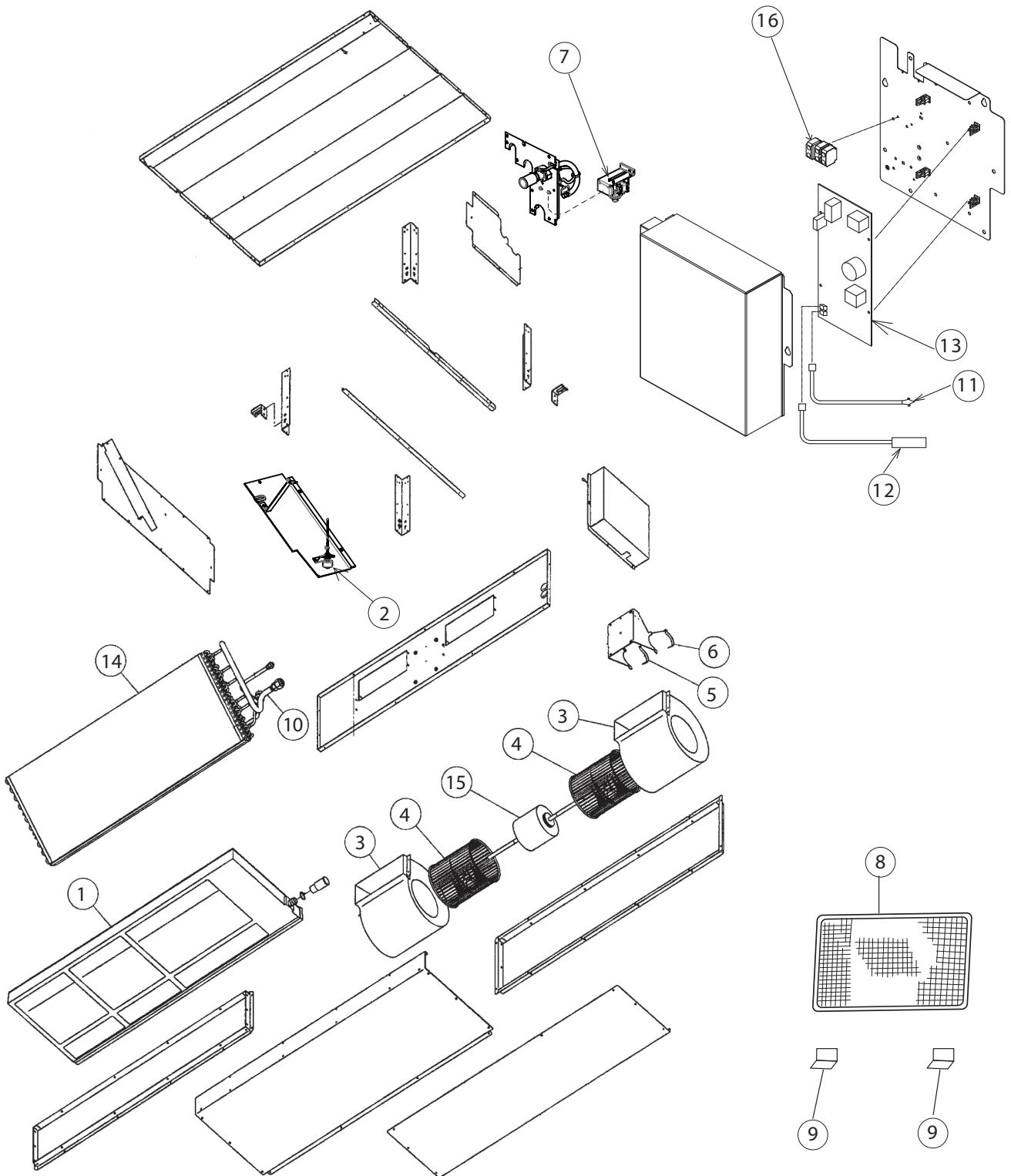

MODEL **RAD-50PPD**

NO.	PART NUMBER	Q'TY / UNIT	DESCRIPTION
1	PMRAD-50DH7 003	1	DRAIN PAN ASSY
2	PMRAD-50DH7 004	1	FIOAT SWITCH
3	PMRAD-50DH7 006	2	FAN CASING
4	PMRAD-50DH7 007	2	FAN COVER
5	PMRAD-50DH7 008	1	BAND (L)
6	PMRAD-50DH7 009	1	BAND (R)
7	PMRAD-50DH7 010	1	DRAIN PUMP
8	PMRAD-50DH7 011	1	FILTER
9	PMRAD-50DH7 012	2	FILTER PLATE
10	PMRAD-50DH7 013	1	THERMISTOR SUPPORT
11	PMRAD-50DH7 014	1	ROOM THERMISTOR
12	PMRAD-50DH7 015	1	THERMISTOR
13	PMRAD-50PPD R01	1	P.W.B MAIN
14	PMRAD-50PPD R02	1	CYCLE ASSY
15	PMRAD-50PPD R03	1	FAN MOTOR
16	PMRAD-50PPD R04	1	3P-TERMINAL

MODEL **RAD-60PPD**

NO.	PART NUMBER	Q'TY / UNIT	DESCRIPTION
1	PMRAD-50DH7 003	1	DRAIN PAN ASSY
2	PMRAD-50DH7 004	1	FIOAT SWITCH
3	PMRAD-50DH7 006	2	FAN CASING
4	PMRAD-50DH7 007	2	FAN COVER
5	PMRAD-50DH7 008	1	BAND (L)
6	PMRAD-50DH7 009	1	BAND (R)
7	PMRAD-50DH7 010	1	DRAIN PUMP
8	PMRAD-50DH7 011	1	FILTER
9	PMRAD-50DH7 012	2	FILTER PLATE
10	PMRAD-50DH7 013	1	THERMISTOR SUPPORT
11	PMRAD-50DH7 014	1	ROOM THERMISTOR
12	PMRAD-50DH7 015	1	THERMISTOR
13	PMRAD-60PPD R01	1	P.W.B MAIN
14	PMRAD-50PPD R02	1	CYCLE ASSY
15	PMRAD-50PPD R03	1	FAN MOTOR
16	PMRAD-50PPD R04	1	3P-TERMINAL

PART LIST AND DIAGRAM

OUTDOOR UNIT
MODEL : RAC-50NPD
RAC-60NPD

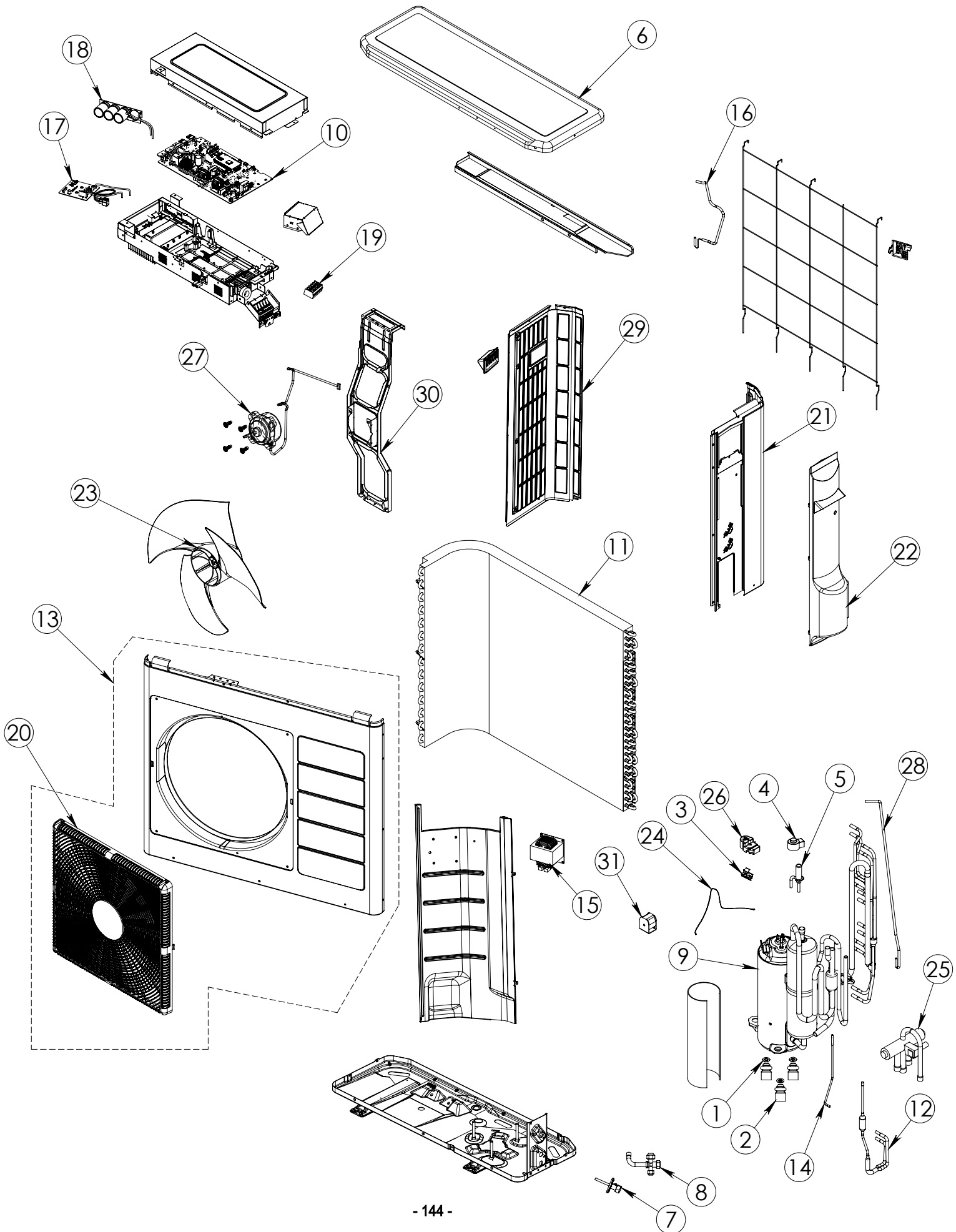

MODEL RAC-50NPD

NO.	PART NO. RAC-50NPD		Q'TY / UNIT	PARTS NAME
1	PMKPNT1	001	4	PUSH NUT
2	PMRAC-2226HV	805	3	COMPRESSOR RUBBER
3	PMRAC-25NH4	S09	1	OVERHEAT THERMISTOR SUPPORT
4	PMRAC-25NPA	S02	1	ELECTRICAL EXPANSION COIL
5	PMRAC-25NPA	S03	1	EXPANSION VALVE
6	PMRAC-30MH1	S05	1	TOP COVER
7	PMRAC-50NH4	S03	1	VALVE (2S)
8	PMRAC-50NH4	S04	1	VALVE (4S)
9	PMRAC-50NPD	S01	1	COMPRESSOR
10	PMRAC-50NPD	S02	1	P.W.B (MAIN)
11	PMRAC-50NPD	S03	1	CONDENSOR
12	PMRAC-50NPD	S04	1	STRAINER (COND)
13	PMRAC-50NPD	S05	1	CABINET
14	PMRAC-50NPD	S06	1	STRAINER(PIPE)
15	PMRAC-50YHA2	S04	1	REACTOR
16	PMRAC-50YHA2	S08	1	THERMISTOR (OUTSIDE TEMPERATURE)
17	PMRAC- 50YHA4	S02	1	IPM BOARD
18	PMRAC-50YHA4	S03	1	CAPACITOR BOARD
19	PMRAC-50YHA4	S04	1	TERMINAL BOARD (5P)
20	PMRAC-50NPD	S07	1	D-GRILL
21	PMRAC-60YHA4	S03	1	SIDE PLATE R
22	PMRAC-60YHA4	S04	1	SV-COVER- ASSY
23	PMRAC-70YHA	S07	1	PROPELLER FAN
24	PMRAC-80YHA	S14	1	THERMISTOR (OH)
25	PMRAC-S18CPA	S02	1	REVERSING VALVE
26	PMRAC-X13CX	906	1	OVERLOAD RELAY COVER
27	PMRAM-53NP2B	S10	1	FAN MOTOR
28	PMRAM-65QHA4	S12	1	THERMISTOR (DEFROST)
29	PMRAM-72Q9	S05	1	SIDEPLATE L
30	PMRAM-72Q9	S08	1	SUPPORT (FAN MOTOR)
31	PMRAM-90NP5B	S09	1	MG-COIL (REVERSING VALVE)

MODEL RAC-60NPD

NO.	PART NO. RAC-60NPD		Q'TY / UNIT	PARTS NAME
1	PMKPNT1	001	4	PUSH NUT
2	PMRAC-2226HV	805	3	COMPRESSOR RUBBER
3	PMRAC-25NH4	S09	1	OVERHEAT THERMISTOR SUPPORT
4	PMRAC-25NPA	S02	1	ELECTRICAL EXPANSION COIL
5	PMRAC-25NPA	S03	1	EXPANSION VALVE
6	PMRAC-30MH1	S05	1	TOP COVER
7	PMRAC-50NH4	S03	1	VALVE (2S)
8	PMRAC-50NH4	S04	1	VALVE (4S)
9	PMRAC-50NPD	S01	1	COMPRESSOR
10	PMRAC-60NPD	S01	1	P.W.B (MAIN)
11	PMRAC-50NPD	S03	1	CONDENSOR
12	PMRAC-50NPD	S04	1	STRAINER (COND)
13	PMRAC-50NPD	S05	1	CABINET
14	PMRAC-50NPD	S06	1	STRAINER(PIPE)
15	PMRAC-50YHA2	S04	1	REACTOR
16	PMRAC-50YHA2	S08	1	THERMISTOR (OUTSIDE TEMPERATURE)
17	PMRAC- 50YHA4	S02	1	IPM BOARD
18	PMRAC-50YHA4	S03	1	CAPACITOR BOARD
19	PMRAC-50YHA4	S04	1	TERMINAL BOARD (5P)
20	PMRAC-50NPD	S07	1	D-GRILL
21	PMRAC-60YHA4	S03	1	SIDE PLATE R
22	PMRAC-60YHA4	S04	1	SV-COVER- ASSY
23	PMRAC-70YHA	S07	1	PROPELLER FAN
24	PMRAC-80YHA	S14	1	THERMISTOR (OH)
25	PMRAC-S18CPA	S02	1	REVERSING VALVE
26	PMRAC-X13CX	906	1	OVERLOAD RELAY COVER
27	PMRAM-53NP2B	S10	1	FAN MOTOR
28	PMRAM-65QHA4	S12	1	THERMISTOR (DEFROST)
29	PMRAM-72Q9	S05	1	SIDEPLATE L
30	PMRAM-72Q9	S08	1	SUPPORT (FAN MOTOR)
31	PMRAM-90NP5B	S09	1	MG-COIL (REVERSING VALVE)

HITACHI

RAD-50PPD/RAC-50NPD
RAD-60PPD/RAC-60NPD

PM NO. 0629E

Printed in Malaysia