

SERVICE MANUAL TECHNICAL INFORMATION

FOR SERVICE PERSONNEL ONLY

REFER TO THE FOUNDATION MANUAL

CONTENTS

SPECIFICATIONS-----	4
HOW TO USE -----	8
CONSTRUCTION AND DIMENSIONAL DIAGRAM-----	58
MAIN PARTS COMPONENT -----	60
WIRING DIAGRAM -----	62
CIRCUIT DIAGRAM -----	64
PRINTED WIRING BOARD LOCATION DIAGRAM -----	66
BLOCK DIAGRAM-----	67
BASIC MODE -----	68
REFRIGERATING CYCLE DIAGRAM-----	77
DESCRIPTION OF MAIN CIRCUIT OPERATION-----	78
SERVICE CALL Q & A-----	90
TROUBLE SHOOTING -----	100
AUTO SWING FUNCTION -----	104
PARTS LIST AND DIAGRAM-----	134

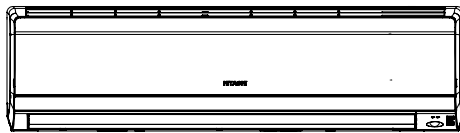

RAK-70PPD

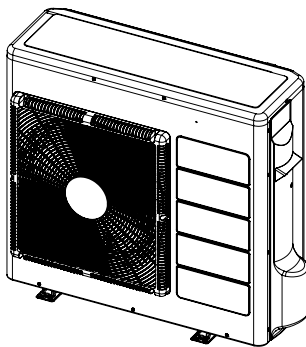

RAC-70NPD

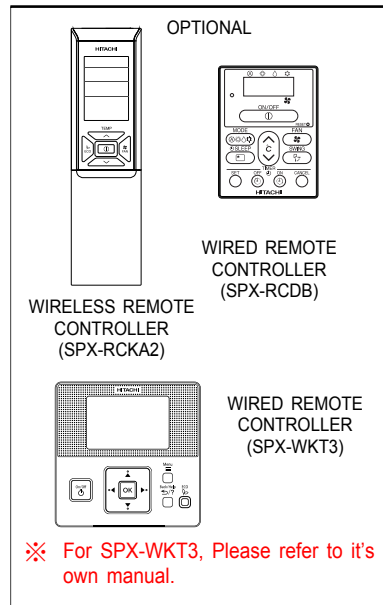

SPECIFICATIONS

TYPE		DC INVERTER (WALL TYPE)	
		INDOOR UNIT	OUTDOOR UNIT
MODEL			
POWER SOURCE		1Ø, 50/60 Hz, 220 ~ 240V	
COOLING	TOTAL INPUT (W)	2000 (300 ~ 2700)	
	TOTAL AMPERES (A)	9.18 ~ 8.42	
	CAPACITY	(kW)	7.00 (1.50 ~ 8.00)
(B.T.U./h)		23,880 (5,116 ~ 27,292)	
HEATING	TOTAL INPUT (W)	2100 (500 ~ 2800)	
	TOTAL AMPERES (A)	9.64 ~ 8.84	
	CAPACITY	(kW)	8.00 (1.50 ~ 8.50)
(B.T.U./h)		27,290 (5,116 ~ 28,997)	
DIMENSIONS (mm)	W	1100	850
	H	300	800
	D	260	298
NET WEIGHT (kg)		15	52

※ After installation

SPECIFICATIONS AND PARTS ARE SUBJECT TO CHANGE FOR IMPROVEMENT

ROOM AIR CONDITIONER

INDOOR UNIT + OUTDOOR UNIT

OCTOBER 2017

SAFETY DURING REPAIR WORK

1. In order to disassemble and repair the unit in question, be sure to disconnect the power cord plug from the power outlet before starting the work.

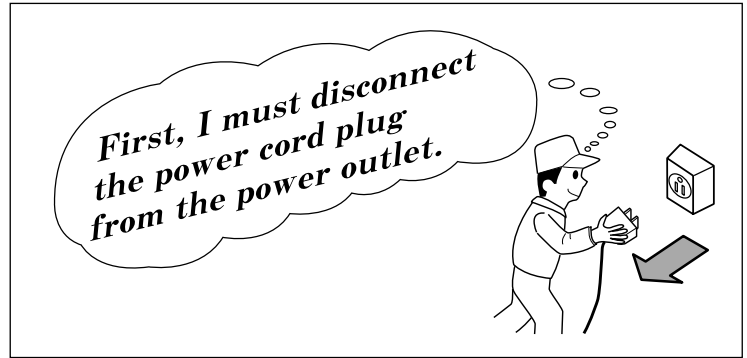

2. If it is necessary to replace any parts, they should be replaced with respective genuine parts for the unit, and the replacement must be effected in correct manner according to the instructions in the Service Manual of the unit.

If the contacts of electrical parts are defective, replace the electrical parts without trying to repair them.

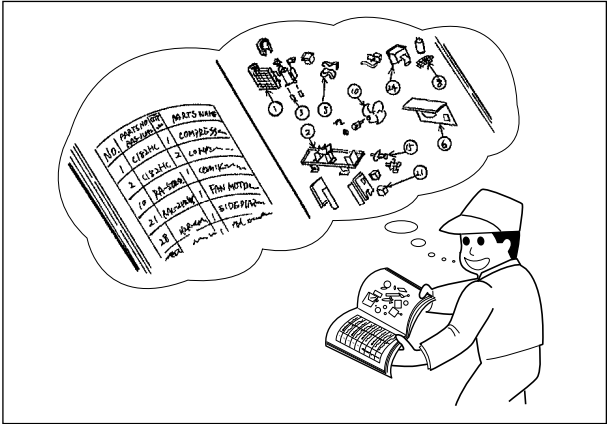

3. After completion of repairs, the initial state should be restored.
4. Lead wires should be connected and laid as in the initial state.
5. Modification of the unit by the user himself should absolutely be prohibited.
6. Tools and measuring instruments for use in repairs or inspection should be accurately calibrated in advance.
7. In installing the unit having been repaired, be careful to prevent the occurrence of any accident such as electrical shock, leak of current, or bodily injury due to the drop of any part.
8. To check the insulation of the unit, measure the insulation resistance between the power cord plug and grounding terminal of the unit. The insulation resistance should be 1MΩ or more as measured by a 500V DC megger.
9. The initial location of installation such as window, floor or the other should be checked for being and safe enough to support the repaired unit again. If it is found not so strong and safe, the unit should be installed at the initial location after reinforced or at a new location.

10. Any inflammable object must not be placed about the location of installation.
11. Check the grounding to see whether it is proper or not, and if it is found improper, connect the grounding terminal to the earth.

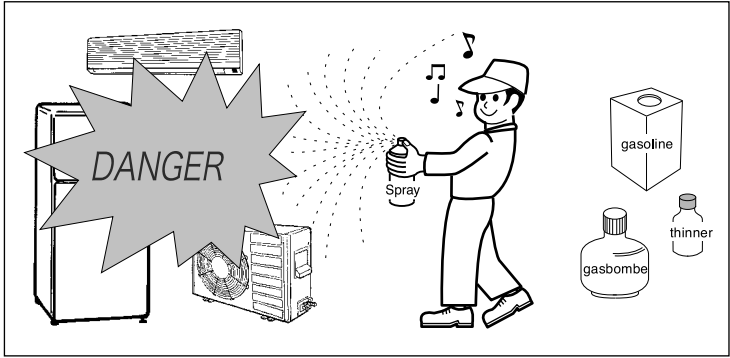

WORKING STANDARDS FOR PREVENTING BREAKAGE OF SEMICONDUCTORS

1. Scope

The standards provide for items to be generally observed in carrying and handling semiconductors in relative manufacturers during maintenance and handling thereof. (They apply the same to handling of abnormal goods such as rejected goods being returned).

2. Object parts

- (1) Micro computer
- (2) Integrated circuits (I.C.)
- (3) Field-effective transistor (F.E.T.)
- (4) P.C. boards or the like to which the parts mentioned in (1) and (2) of this paragraph are equipped.

3. Items to be observed in handling

- (1) Use a conductive container for carrying and storing of parts. (Even rejected goods should be handled in the same way).

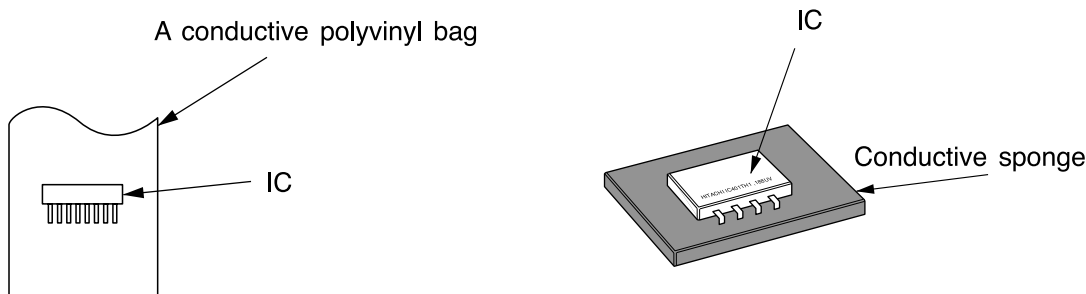

Fig. 1. Conductive container

- (2) When any part is handled uncovered (in counting, packing and the like), the handling person must always use himself as a body earth. (Make yourself a body earth by passing $1M\Omega$ earth resistance through a ring or bracelet).
- (3) Be careful not to touch the parts with your clothing when you hold a part even if a body earth is being taken.
- (4) Be sure to place a part on a metal plate with grounding.
- (5) Be careful not to fail to turn off power when you repair the printed circuit board. At the same time, try to repair the printed circuit board on a grounded metal plate.

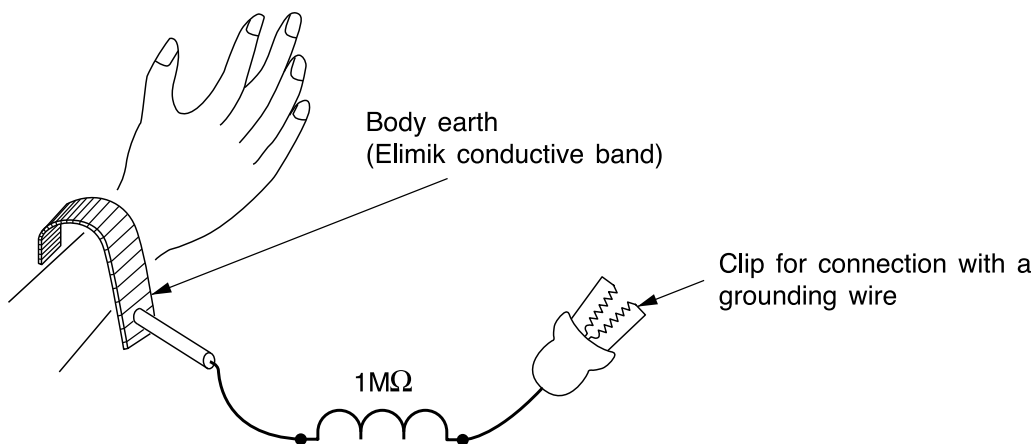

Fig. 2. Body Earth

(6) Use a three wire type soldering iron including a grounding wire.

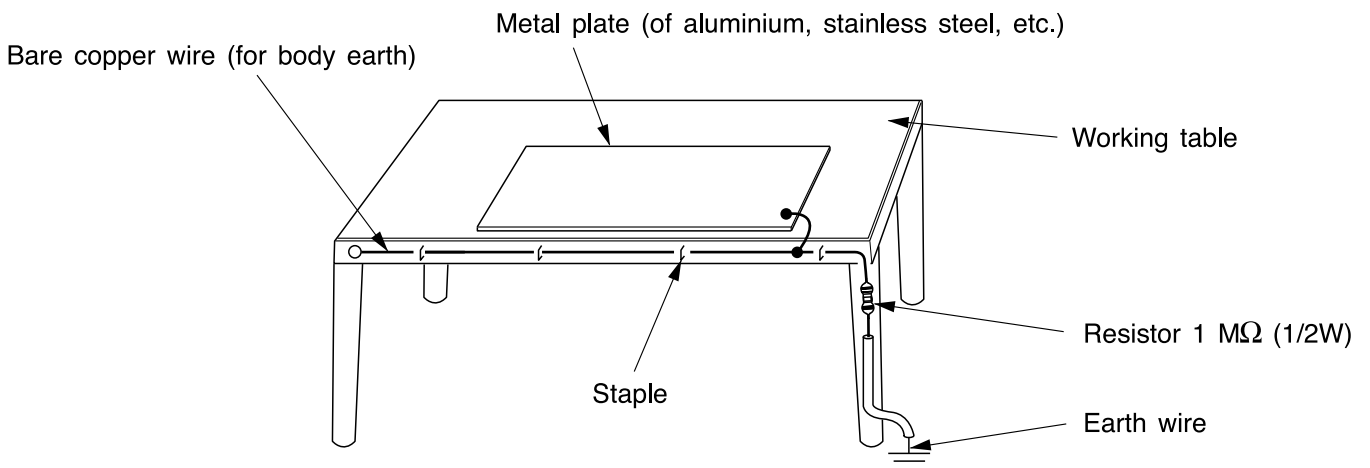

Fig. 3. Grounding of the working table

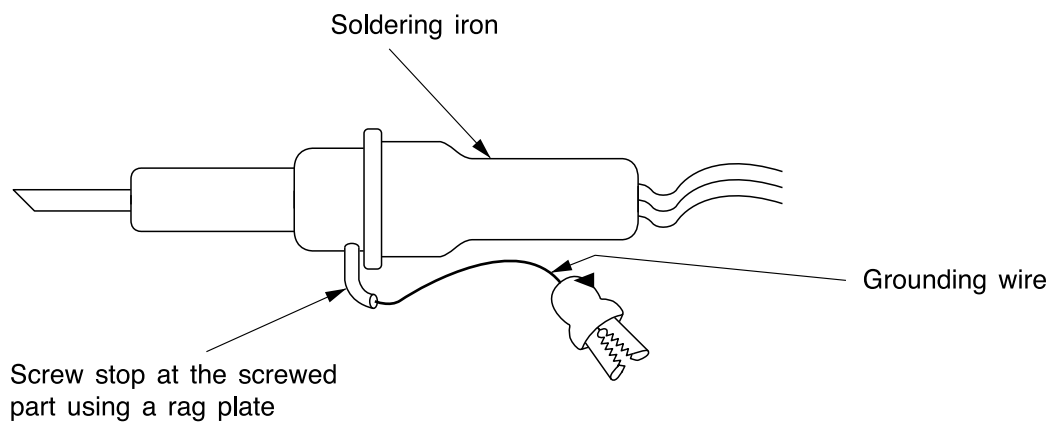

Fig. 4. Grounding a solder iron

Use a high insulation mode (100V, 10MΩ or higher) when ordinary iron is to be used.

(7) In checking circuits for maintenance, inspection or some others, be careful not to have the test probes of the measuring instrument short circuit a load circuit or the like.

SPECIFICATIONS

MODEL		RAK-70PPD	RAC-70NPD
FAN MOTOR		DC38W	DC47W
FAN MOTOR CAPACITOR		NO	NO
FAN MOTOR PROTECTOR		NO	NO
COMPRESSOR		–	JX151XG1
COMPRESSOR MOTOR CAPACITOR		NO	NO
OVERLOAD PROTECTOR		NO	NO
OVERHEAT PROTECTOR		NO	YES
FUSE (for MICROPROCESSOR)		3.15A	3A
POWER RELAY		NO	G4A
POWER SWITCH		NO	NO
TEMPORARY SWITCH		YES	NO
TEST/SERVICE SWITCH		YES	NO
TRANSFORMER		NO	NO
VARISTOR		NO	450NR
NOISE SUPPRESSOR		NO	YES
THERMOSTAT		YES(IC)	YES(IC)
REMOTE CONTROL SWITCH (LIQUID CRYSTAL)		YES	NO
REFRIGERANT CHARGING VOLUME (Refrigerant R32)	UNIT	-----	1600g
	PIPES (MAX. 30m) (MIN. 3m)	CHARGELESS	

Figure showing the installation of Indoor unit

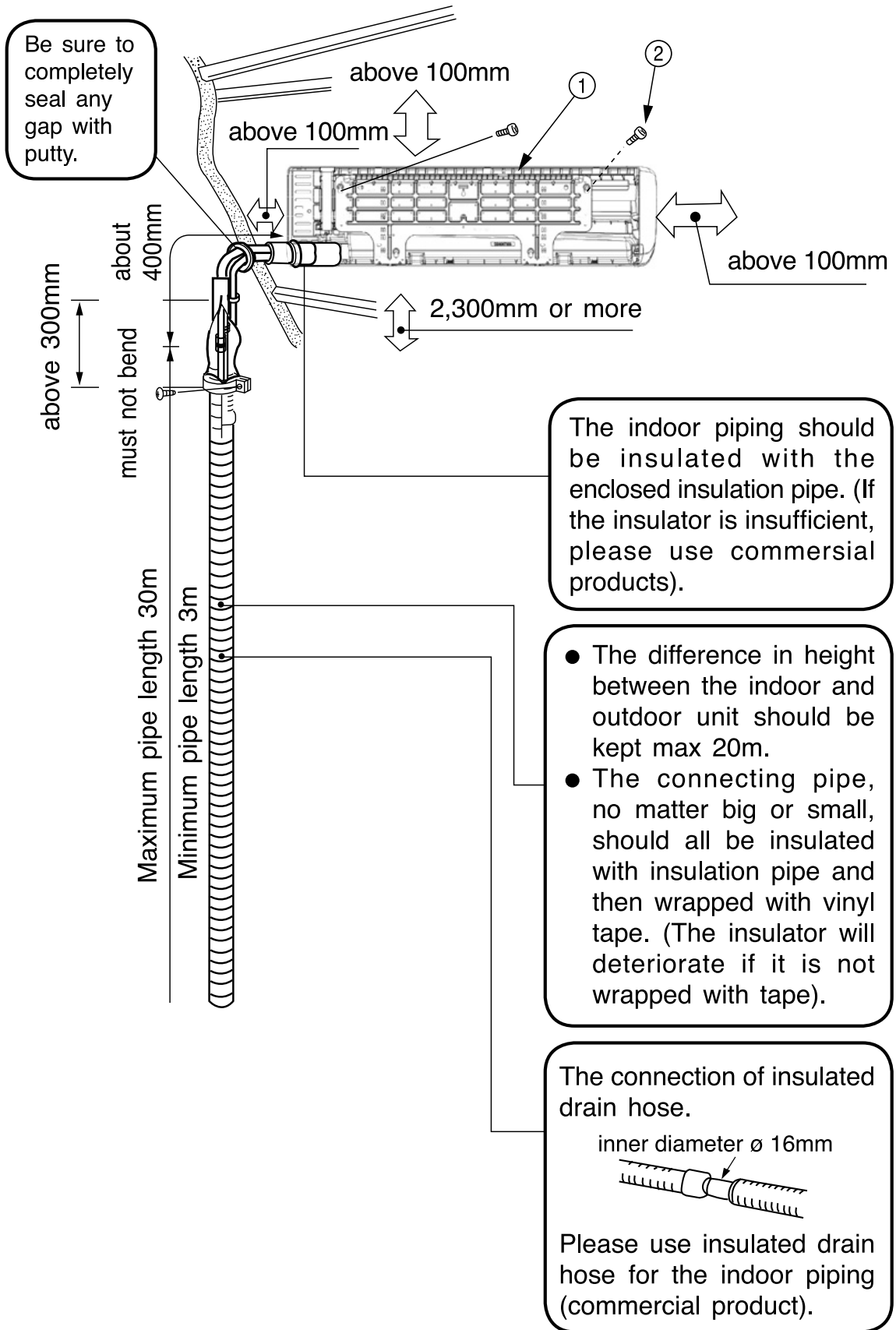
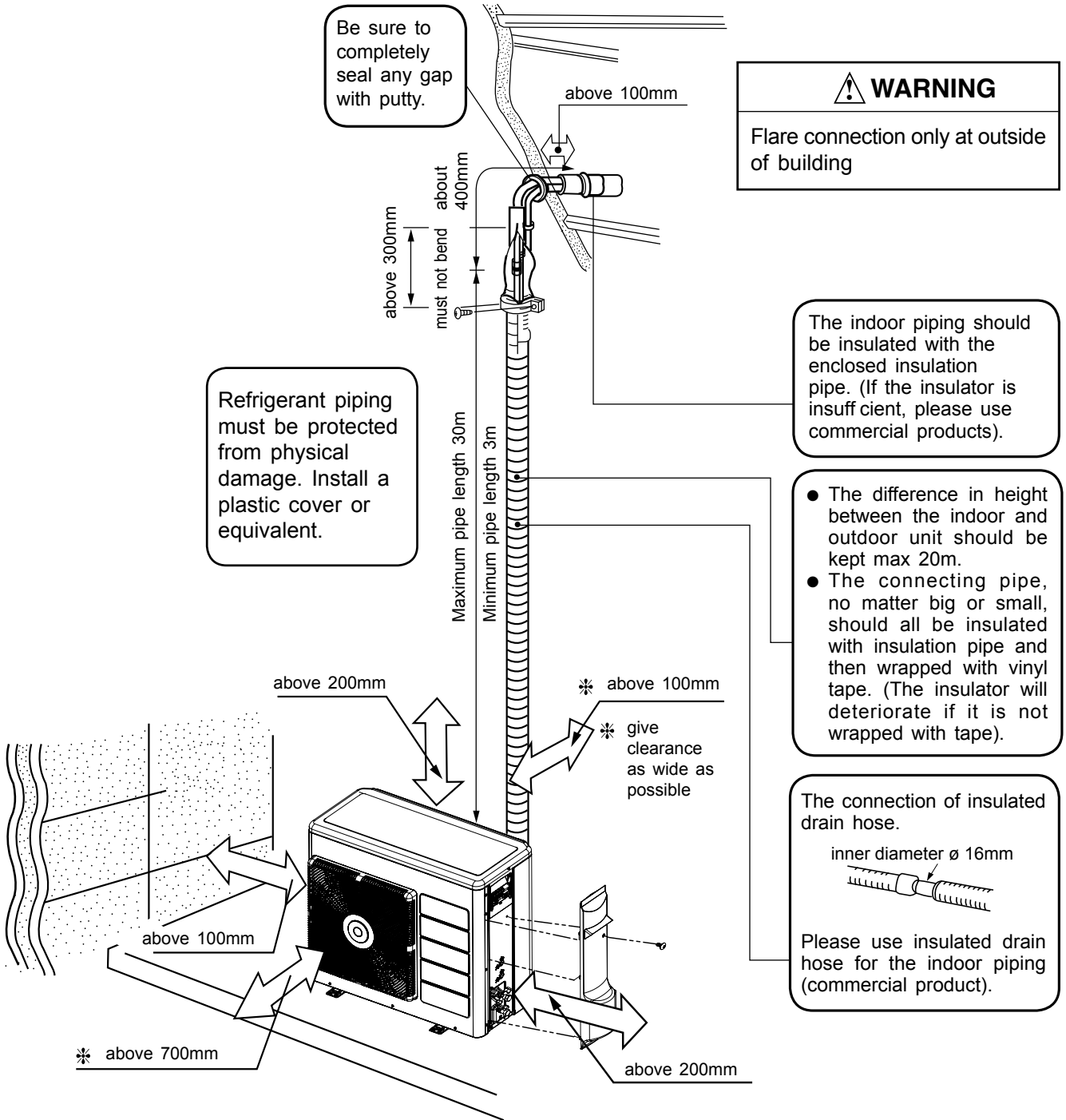

Figure showing the installation of Outdoor unit





 **CAUTION**





1. In quiet or stop operation, slight flowing noise of refrigerant in the refrigerating cycle is heard occasionally, but this noise is not abnormal for the operation.
2. When it thunders nearby, it is recommended to stop the operation and to disconnect the power cord plug from the power outlet for safety.
3. In the event of power failure, the airconditioner will restart automatically in the previously selected mode once the power is restored. In the event of power failure during TIMER operation, the airconditioner will not start automatically. Re-press START/STOP button after 3 minutes from when unit stopped or power recovery.
4. If the room air conditioner is stopped by adjusting thermostat, or miss operation, and re-start in a moment, there is occasion that the cooling and heating operation does not start for 3 minutes, it is not abnormal and this is the result of the operation of IC delay circuit. This IC delay circuit ensures that there is no danger of blowing fuse or damaging parts even if operation is restarted accidentally.
5. This room air conditioner should not be used at the cooling operation when the outside temperature is below -10°C (14°F).
6. This room air conditioner (the reverse cycle) should not be used when the outside temperature is below -15°C (5°F).
If the reverse cycle is used under this condition, the outside heat exchanger is frosted and efficiency falls.



SAFETY PRECAUTION





- Please read the "Safety Precaution" carefully before operating the unit to ensure correct usage of the unit.
- Pay special attention to signs of "▲ Warning" and "▲ Caution". The "Warning" section contains matters which, if not observed strictly, may cause death or serious injury. The "Caution" section contains matters which may result in serious consequences if not observed properly. Please observe all instructions strictly to ensure safety.
- The sign indicate the following meanings.

 Make sure to connect earth line.	 The sign in the figure indicates prohibition.
 Indicates the instructions that must be followed.	



 WARNING	This symbol shows that this equipment uses a flammable refrigerant. If the refrigerant is leaked, together with an external ignition source, there is a possibility of ignition.
 CAUTION	This symbol shows that the Operation Instructions should be read carefully.
 CAUTION	This symbol shows that a service personnel should be handling this equipment with reference to the Installation Manual.
 CAUTION	This symbol shows that there is information included in the Operation Manual and/or Installation Manual

- Please keep this manual after reading.







PRECAUTIONS DURING INSTALLATION

 WARNING	<ul style="list-style-type: none"> ● Do not reconstruct the unit. Water leakage, fault, short circuit or fire may occur if you reconstruct the unit by yourself.  ● Please ask your sales agent or qualified technician for the installation of your unit. Water leakage, short circuit or fire may occur if you install the unit by yourself.
	<ul style="list-style-type: none"> ● Please use earth line. Do not place the earth line near water or gas pipes, lightning-conductor, or the earth line of telephone. Improper installation of earth line may cause electric shock.  ● Be sure to use the specified piping set for R32. Otherwise, this may result in broken copper pipes or faults. ● Do not use refrigerant other than the one indicated on the outdoor unit (R32) when installing, moving or repairing. Using other refrigerants may cause trouble or damage to the unit, and personal injury.
 CAUTION	<ul style="list-style-type: none"> ● A circuit breaker should be installed depending on the mounting site of the unit. Without a circuit breaker, the danger of electric shock exists. ● Do not install near location where there is flammable gas. The outdoor unit may catch fire if flammable gas leaks around it.  ● Please ensure smooth flow of water when installing the drain hose. ● Do not install the indoor unit in a machine shop or kitchen where vapor from oil or its mist flows to the indoor unit. The oil will deposit on the heat exchanger, thereby reducing the indoor unit performance and may deform and in the worst case, break the plastic parts of the indoor unit.

PRECAUTIONS DURING SHIFTING OR MAINTENANCE

 WARNING	<ul style="list-style-type: none"> ● Should abnormal situation arises (like burning smell), please stop operating the unit and turn off the circuit breaker. Contact your agent. Fault, short circuit or fire may occur if you continue to operate the unit under abnormal situation. 
	<ul style="list-style-type: none"> ● Please contact your agent for maintenance. Improper self maintenance may cause electric shock and fire.
	<ul style="list-style-type: none"> ● Please contact your agent if you need to remove and reinstall the unit. Electric shock or fire may occur if you remove and reinstall the unit yourself improperly.
	<ul style="list-style-type: none"> ● If the supply cord is damaged, it must be replaced by the special cord obtainable at authorized service/parts centers.

PRECAUTIONS DURING OPERATION

 WARNING	<ul style="list-style-type: none"> ● Avoid an extended period of direct air flow for your health. 
	<ul style="list-style-type: none"> ● Do not insert a finger, a rod or other objects into the air outlet or inlet. As the fan is rotating at a high speed, it will cause injury. Before cleaning, be sure to stop the operation and turn the breaker OFF. 
	<ul style="list-style-type: none"> ● Do not use any conductor as fuse wire, this could cause fatal accident. 
	<ul style="list-style-type: none"> ● During thunder storm, disconnect and turn off the circuit breaker. 
	<ul style="list-style-type: none"> ● Spray cans and other combustibles should not be located within a meter of the air outlets of both indoor and outdoor units. As a spray can's internal pressure can be increased by hot air, a rupture may result. 

PRECAUTIONS DURING OPERATION

- The product shall be operated under the manufacturer specification and not for any other intended use.

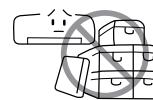

- Do not attempt to operate the unit with wet hands, this could cause fatal accident.

- When operating the unit with burning equipments, regularly ventilate the room to avoid oxygen insufficiency.

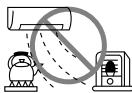
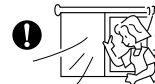

- Do not direct the cool air coming out from the air-conditioner panel to face household heating apparatus as this may affect the working of apparatus such as the electric kettle, oven etc.

- Please ensure that outdoor mounting frame is always stable, firm and without defect. If not, the outdoor unit may collapse and cause danger.



- Do not splash or direct water to the body of the unit when cleaning it as this may cause short circuit.

- Do not use any aerosol or hair sprays near the indoor unit. This chemical can adhere on heat exchanger fin and blocked the evaporation water flow to drain pan. The water will drop on tangential fan and cause water splashing out from indoor unit.



C
A
U
T
I
O
N



- Please switch off the unit and turn off the circuit breaker during cleaning, the high-speed fan inside the unit may cause danger.

- Turn off the circuit breaker if the unit is not to be operated for a long period.



- Do not climb on the outdoor unit or put objects on it.

- Do not put water container (like vase) on the indoor unit to avoid water dripping into the unit. Dripping water will damage the insulator inside the unit and causes short-circuit.

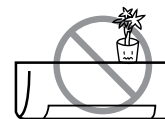

- Do not place plants directly under the air flow as it is bad for the plants.

- When operating the unit with the door and windows opened, (the room humidity is always above 80%) and with the air deflector facing down or moving automatically for a long period of time, water will condense on the air deflector and drips down occasionally. This will wet your furniture. Therefore, do not operate under such condition for a long time.

- If the amount of heat in the room is above the cooling or heating capability of the unit (for example: more people entering the room, using heating equipments and etc.), the preset room temperature cannot be achieved.

- This appliance can be used by children aged from 8 years and above and persons with reduced physical, sensory or mental capabilities or lack of experience and knowledge if they have been given supervision or instruction concerning use of the appliance in a safe way and understand the hazards involved. Children shall not play with the appliance. Cleaning and user maintenance shall not be made by children without supervision.

NAMES AND FUNCTIONS OF EACH PART

INDOOR UNIT

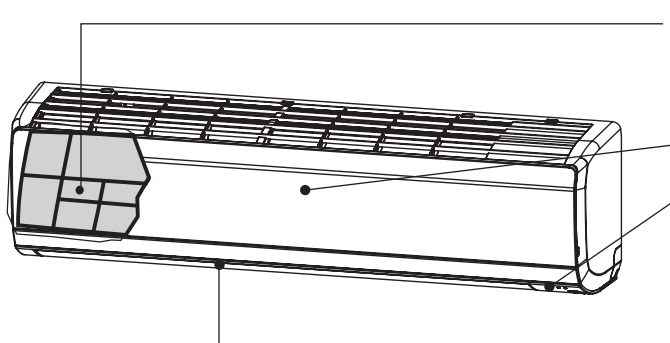

- PRE-FILTER**
To prevent dust from coming into the indoor unit.
(Refer page 15)
- FRONT PANEL**
- INDOOR UNIT INDICATORS**
Light indicator showing the operating condition.
(Refer page 11)
- HORIZONTAL DEFLECTOR • VERTICAL DEFLECTOR (AIR OUTLET)**

OUTDOOR UNIT

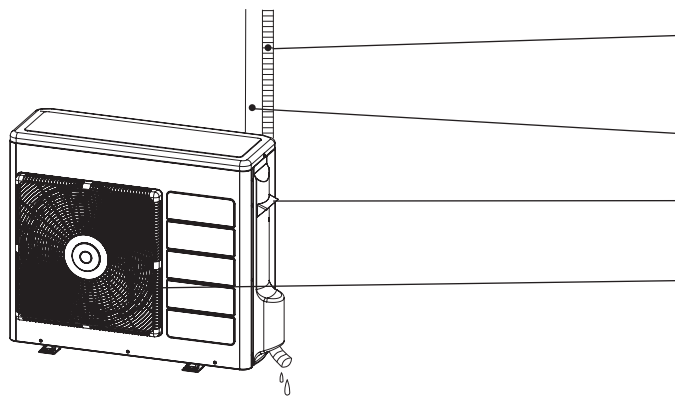

- DRAIN PIPE**
Condensed water drain to outside.
- CONNECTING CORD**
- AIR INLET (BACK, LEFT SIDE)**
- AIR OUTLET**

⚠ CAUTION

- When heating operation, drain or defrosted water flows out from outdoor unit. Don't close drain outlet portion in chilly area so as not to freeze these.

MODEL NAME AND DIMENSIONS

MODEL	WIDTH (mm)	HEIGHT (mm)	DEPTH (mm)
RAK-70PPD	1100	300	260
RAC-70NPD	850	800	298

INDOOR UNIT INDICATORS

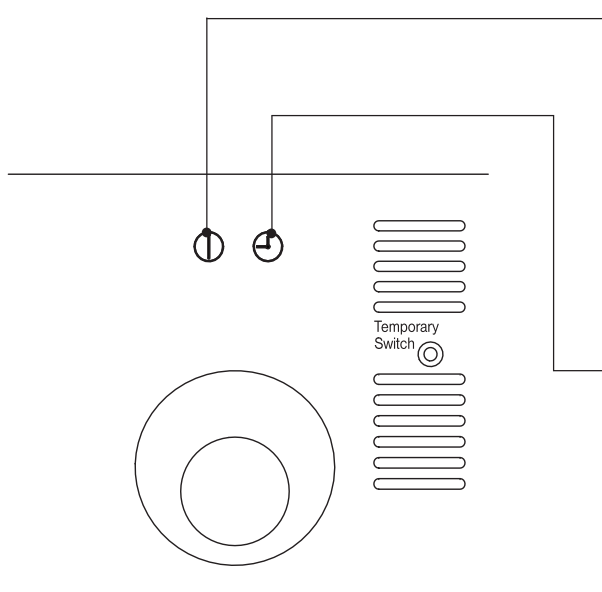

OPERATION LAMP

This lamp lights during operation.
The OPERATION LAMP flashes/dimmed in the following cases during heating

(1) During preheating

For about 2–3 minutes after starting up.

(2) During defrosting

Defrosting will be performed about once every one hour when frost forms on the heat exchanger of the outdoor unit, for 5–10 minutes each time.

TIMER LAMP

This lamp lights when the timer is working.

OPERATION INDICATOR

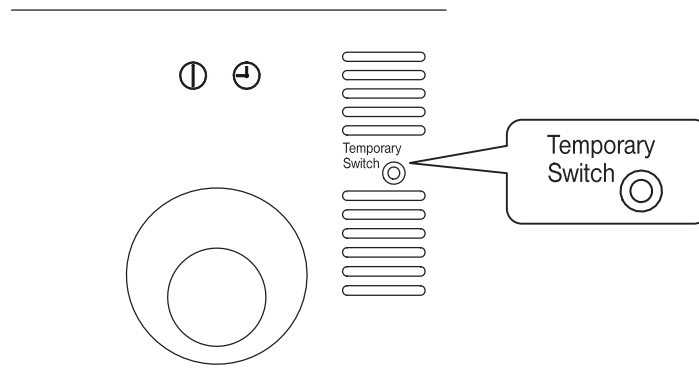

TEMPORARY SWITCH

Use this switch to start and stop when the remote controller does not work. [Use non-conductor stick (example: toothpick)]

- By pressing the temporary switch, the operation is done in automatic mode.
- When the operation is done using the temporary switch after the power source is turned off and turn on again, the operation is done in automatic mode.

THE IDEAL WAYS OF OPERATION

Suitable Room Temperature

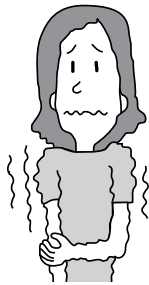

⚠ Warning
Freezing temperature is bad for health and a waste of electric power.

Install curtain or blinds

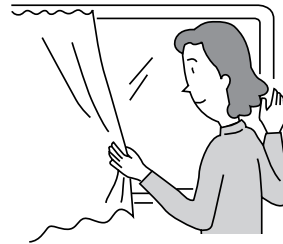

It is possible to reduce heat entering the room through windows.

Ventilation

⚠ Caution
Do not close the room for a long period of time. Occasionally open the door and windows to allow the entrance of fresh air.



Effective Usage Of Timer

At night, please use the “OFF or ON timer operation mode”, together with your wake up time in the morning. This will enable you to enjoy a comfortable room temperature. Please use the timer effectively.

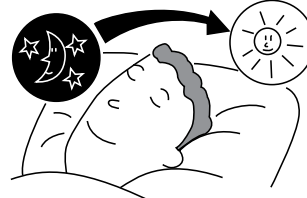

Do Not Forget To Clean The Pre-Filter

Dusty pre-filter will reduce the air volume and the cooling efficiency. To prevent from wasting electric energy, please clean the pre-filter every 2 weeks.

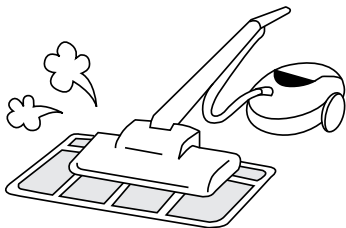

Please Adjust Suitable Temperature For Baby And Children

Please pay attention to the room temperature and air flow direction when operating the unit for baby, children and old folks who have difficulty in movement.

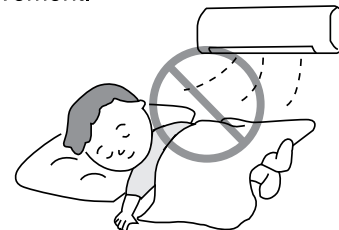

FOR USER'S INFORMATION

The Air Conditioner And The Heat Source In The Room

⚠ Caution

If the amount of heat in the room is above the cooling capability of the air conditioner (for example: more people entering the room, using heating equipments and etc.), the preset room temperature cannot be achieved.

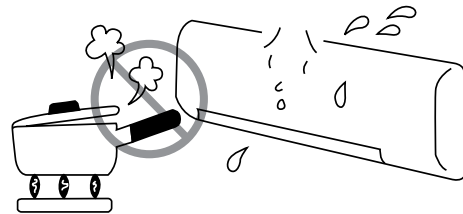

Not Operating For A Long Time

When the indoor unit is not to be used for a long period of time, please switch off the power from the mains. If the power from mains remains "ON", the indoor unit still consumes about 3W in the operation control circuit even if it is in "OFF" mode.

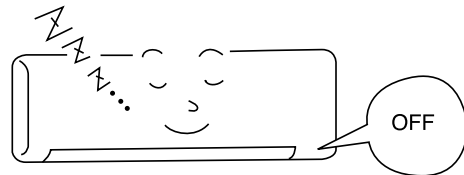

When Lightning Occurs

⚠ Warning

To protect the whole unit during lightning, please stop operating the unit and remove the plug from the socket.

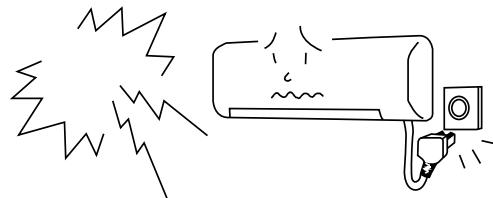

Interference From Electrical Products

⚠ Caution

To avoid noise interference, please place the indoor unit and its remote controller at least 1m away from electrical products.

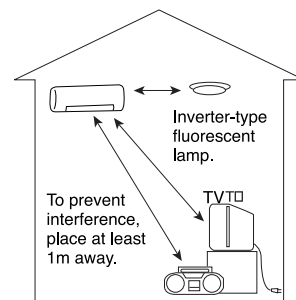

ATTACHING THE AIR PURIFYING FILTERS

1

Open the front panel

- Pull up the front panel by holding it at both sides with both hands.

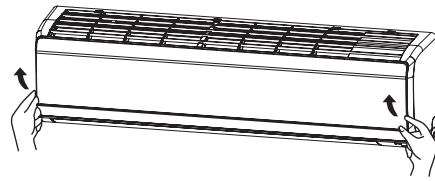

2

Remove the Pre-filter

- Push upward to release the claws and pull out the Pre-filter.

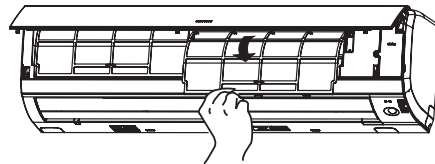

3

Attaching the air purifying filters

- Attach the air purifying filters to the frame by gently compress its both sides and release after insertion into Pre-filter frame.

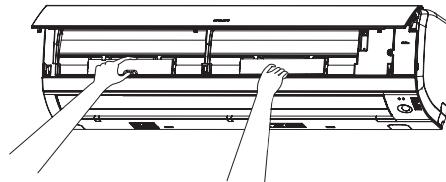

CAUTION

Do not bend the air purifying filter as it may cause damage to the structure.

Please do not smell direct from source of filter.

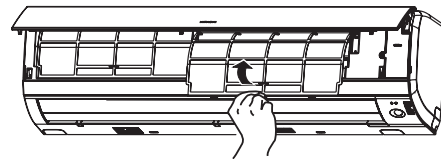

4

Attach the Pre-filters

- Attach the Pre-filters by ensuring that the surface written "FRONT" is facing front.
- After attaching the Pre-filters, push the front panel at three arrow portions as shown in figure and close it.

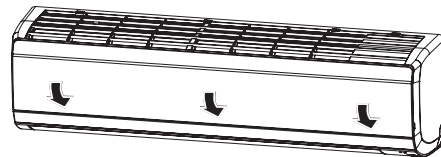

NOTE

- In case of removing the air purifying filters, please follow the above procedures.
- The cooling capacity is slightly weakened and the cooling speed becomes slower when the air purifying filters are used. So, set the fan speed to "HIGH" when using it in this condition.
- The air purifying filters are not washable. It is recommended to use vacuum to clean. It can be used for 1 year. When you want to renew it, please ask your sales agent.
Type number for this air purifying filter is <SPX-NTW4>. Please use this number for ordering when you want to replace it.
- Do not use detergent on the air purifying filter as some detergent may deteriorate the air purifying filter electrostatic performance.



MAINTENANCE

⚠ CAUTION

Cleaning and maintenance must be carried out only by qualified service personnel. Before cleaning, stop operation and switch off the power supply.

1. PRE-FILTER

Clean the Pre-filter, as it removes dust inside the room. In case the Pre-filter is full of dust, the air flow will decrease and the cooling capacity will be reduced. Further, noise may occur. Be sure to clean the Pre-filter following the procedure below.

PROCEDURE

- 1 Open the front panel and remove the Pre-filter
 - Gently lift and remove the air purifying filters from the air purifying filter frame.

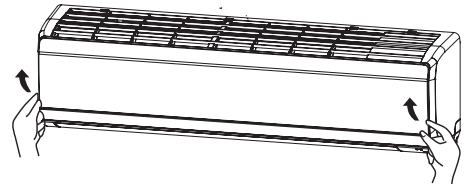

- 2 Vacuum dust from the Pre-filter and air purifying filter using vacuum cleaner. If there is too much dust, rinse under running tap water and gently brush it with soft bristle brush. Allow filters to dry in shade.

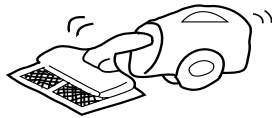
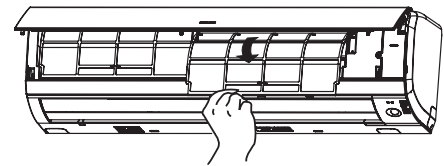

- 3
 - Re-insert the air purifying filter to the filter frame. Set the Pre-filter with "FRONT" mark facing front, and slot them into the original state.
 - After attaching the Pre-filters, push the front panel at three arrow portions as shown in figure and close it.

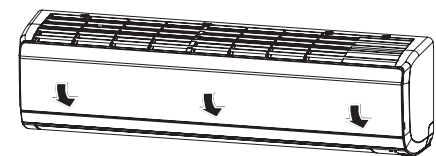

NOTE:

- Air purifying filter should be cleaned every month or sooner if noticeable loading occurs. When used overtime, it may lose its deodorizing function. For maximum performance, it is recommended to replace it every 1 year depending on application requirements.

⚠ CAUTION

- Do not operate the air conditioner without Pre-filter. Dust may enter the air conditioner and fault may occur.

2. CLEANING OF FRONT PANEL

- Remove the front panel and wash with clean water. Wash it with a soft sponge. After using neutral detergent, wash thoroughly with clean water.
- When front panel is not removed, wipe it with a soft dry cloth. Wipe the remote controller thoroughly with a soft dry cloth.
- Wipe the water thoroughly. If water remains at indicators or signal receiver of indoor unit, it causes trouble.

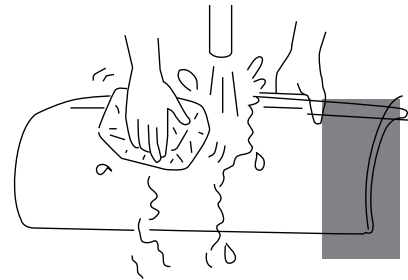

Method of removing the front panel.

Be sure to hold the front panel with both hands to detach and attach it.

Removing the Front Panel



- When the front panel is fully opened with both hands, push the right arm to the outside to release it, and while closing the front panel slightly, pull it out forward.

Attaching the Front Panel

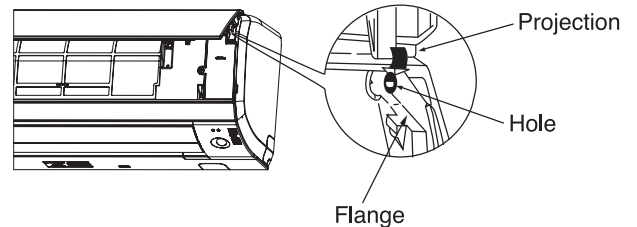

- Move the projections of the left and right arms into the Flanges in the unit and securely insert them into the holes.

CAUTION

- Never use hot water (above 40°C), benzine, gasoline, acid, thinner or a brush, because they will damage the plastic surface and the coating.



CAUTION

Cleaning and maintenance must be carried out only by qualified service personnel. Before cleaning, stop operation and switch off the power supply.

3. MAINTENANCE AT BEGINNING OF LONG OFF PERIOD

- Run the unit by setting the operation mode to  (COOL), the temperature to 32°C and the fan speed to HI for about half a day on a fine day, and dry the whole of the unit.
- Switch off the power plug.

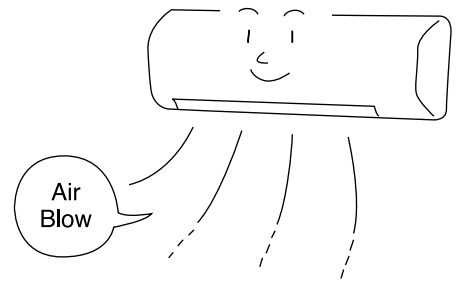

REGULAR INSPECTION

PLEASE CHECK THE FOLLOWING POINTS BY QUALIFIED SERVICE PERSONNEL EITHER EVERY HALF YEARLY OR YEARLY. CONTACT YOUR SALES AGENT OR SERVICE SHOP.

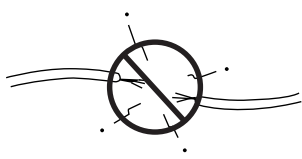
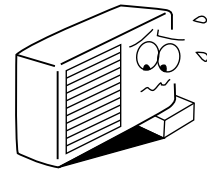
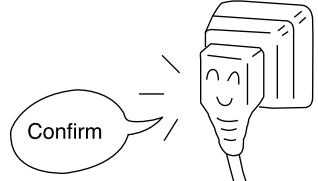
1		Is the earth line disconnected or broken?
2		Is the mounting frame seriously affected by rust and is the outdoor unit tilted or unstable?
3		Is the plug of power line firmly plugged into the socket? (Please ensure no loose contact between them).

AFTER SALE SERVICE AND WARRANTY

WHEN ASKING FOR SERVICE, CHECK THE FOLLOWING POINTS.

CONDITION	CHECK THE FOLLOWING POINTS
<p>If the remote controller is not transmitting a signal. (Remote controller display is dim or blank.)</p>	<ul style="list-style-type: none"> Do the batteries need replacement? Is the polarity of the inserted batteries correct?
<p>When it does not operate</p>	<ul style="list-style-type: none"> Is the fuse all right? Is the voltage extremely high or low? Is the circuit breaker "ON"? Is the setting of operation mode different from other indoor units?
<p>When it does not cool well When it does not heat well</p>	<ul style="list-style-type: none"> Is the pre-filter blocked with dust? Does sunlight fall directly on the outdoor unit? Is the air flow of the outdoor unit obstructed? Are the doors or windows opened, or is there any source of heat in the room? Is the set temperature suitable? Are the air inlets or air outlets of indoor and outdoor units blocked? Is the fan speed "LOW" or "SILENT"?



Notes

- In quiet operation or stopping the operation, the following phenomena may occasionally occur, but they are not abnormal for the operation.
 - Slight flowing noise of refrigerant in the refrigerating cycle.
 - Slight rubbing noise from the fan casing which is cooled and then gradually warmed as operation stops.
- The odor will possibly be emitted from the room air conditioner because the various odor, emitted by smoke, foodstuffs, cosmetics and so on, sticks to it. So the pre-filter and the evaporator regularly must be cleaned to reduce the odor.

- Please contact your sales agent immediately if the air conditioner still fails to operate normally after the above inspections. Inform your agent of the model of your unit, production number, date of installation. Please also inform him regarding the fault.
- Power supply shall be connected at the rated voltage, otherwise the unit will be broken or could not reach the specified capacity.

NOTE:

- If the supply cord is damaged, it must be replaced by the special cord obtainable at authorized service parts centers.
- On switching on the equipment, particularly when the room light is dimmed, a slight brightness fluctuation may occur. This is of no consequence.
The conditions of the local Power Supply Companies are to be observed.

Remote Controller Manual





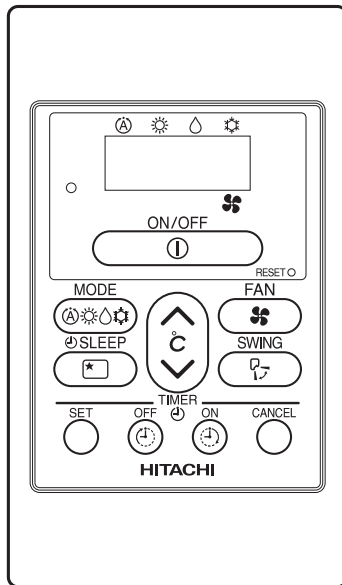





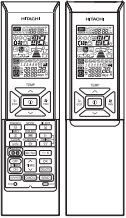







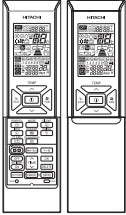







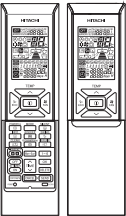







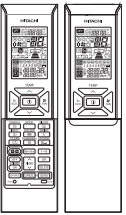



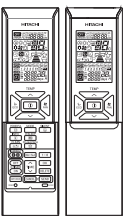

MODEL

**SPX-RCDB
(RAR-5G2)**



PRECAUTIONS FOR USE

- In case of power failure happen, Wired Remote Controller may not show current operating mode when power comes back. However unit will continue to operate at previous setting mode.
- Some features of Wireless Remote Controller are not available when use Wired Remote Controller as mentioned below:

Standard Wireless Remote Controller	Features not available on Wired Remote Controller
<p>RAR-6N1</p> 	<ul style="list-style-type: none"> • Powerful  • Information  • One touch clean  • Leave home  • Silent  • Weekly timer  • Auto swing (horizontal)  • ECO 
<p>RAR-6N2</p> 	<ul style="list-style-type: none"> • Powerful  • Information  • One touch clean  • Leave home  • Silent  • Weekly timer  • ECO 
<p>RAR-6N3</p> 	<ul style="list-style-type: none"> • Powerful  • Information  • One touch clean  • Leave home  • Silent  • Weekly timer  • Air purify  • ECO 
<p>RAR-6N4</p> 	<ul style="list-style-type: none"> • Powerful  • Information  • One touch clean  • Leave home  • Silent  • Weekly timer  • Extended  • ECO 
<p>RAR-6N5</p> 	<ul style="list-style-type: none"> • Powerful  • Information  • One touch clean  • Leave home  • Silent  • Weekly timer  • ECO 

NAMES AND FUNCTIONS OF REMOTE CONTROLLER

■ This controls the operation function and timer setting of the room air conditioner.

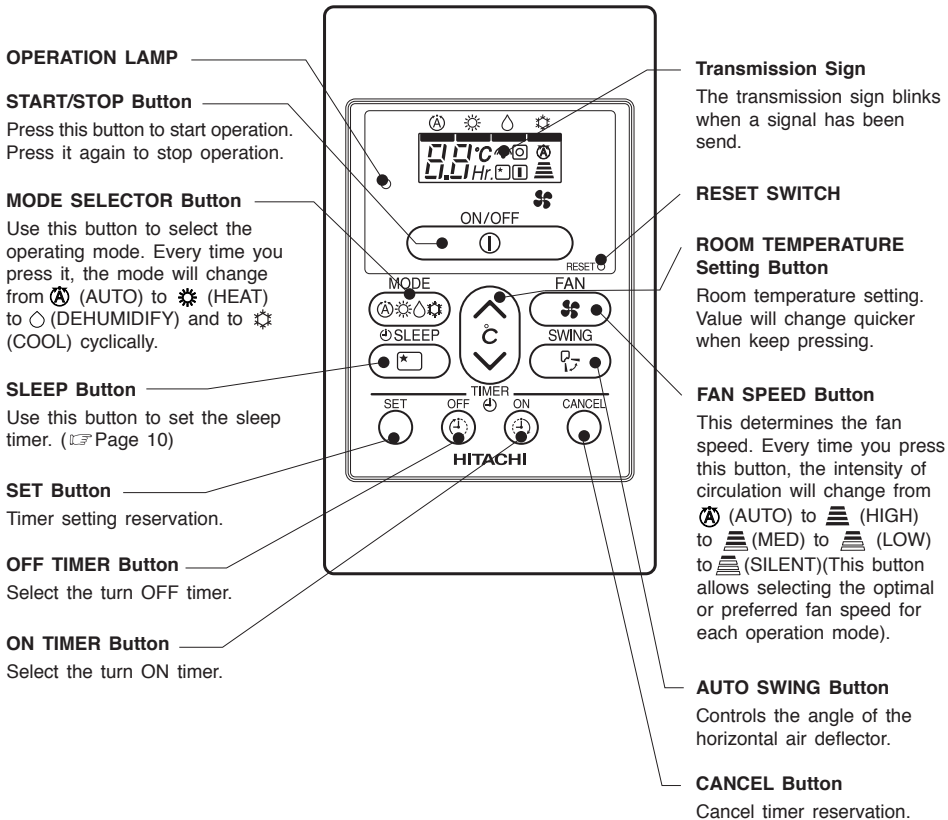

Precautions for Use

- Do not put the remote controller in the following places.
 - Under direct sunlight.
 - In the vicinity of a heater.
- Handle the remote controller carefully. Do not drop it on the floor, and protect it from water.
- Once the outdoor unit stops, it will not restart for about 3 minutes (unless you turn the power switch off and on or unplug the power cord and plug it in again).
This is to protect the device and does not indicate a failure.
- If you press the MODE SELECTOR button during operation, the device may stop for about 3 minutes for protection.

VARIOUS FUNCTIONS

Auto Restart Control

- If there is a power failure, operation will be automatically restarted when the power is resumed with previous operation mode.
(As the operation is not stopped by remote controller.)
 - If you intend not to continue the operation when the power is resumed, switch off the power supply. When you switch on the circuit breaker, the operation will be automatically restarted with previous operation mode.
- Note: 1. If you do not require Auto Restart Control, please consult your sales agent.
2. Auto Restart Control is not available when Timer or Sleep Timer mode is set.

AUTOMATIC OPERATION

The device will automatically determine the mode of operation, HEAT or COOL depending on the current room temperature. The selected mode of operation will change when the room temperature varies.

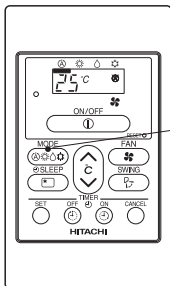

1

Press the MODE selector button so that the display indicates the **A** (AUTO) mode of operation.

- When AUTO has been selected, the device will automatically determine the mode of operation, HEAT or COOL depending on the current room temperature. However the mode of operation will not change when indoor unit is connected to multi type outdoor unit.
- If the mode automatically selected by the unit is not satisfactory, manually change the mode setting (HEAT, DEHUMIDIFY or COOL).

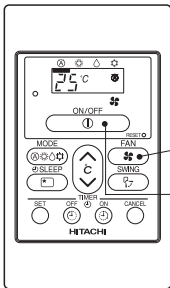

2

Press the **FAN SPEED** button to select AUTO, HIGH, MED, LOW or SILENT.

Set the desired FAN SPEED with the **FAN SPEED** button (the display indicates the setting).

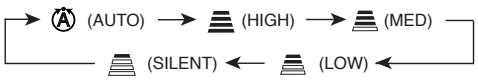

START STOP

Press the **START/STOP** button.
Operation starts.
Press the button again to stop operation.

- As the settings are stored in memory in the remote controller, you only have to press the **START/STOP** button next time.

HEATING OPERATION

- Use the device for heating when the outdoor temperature is under 21°C. When it is too warm (over 21°C), the heating function may not work in order to protect the device.
- In order to maintain reliability of the device, please use this device when outdoor temperature is above -15°C

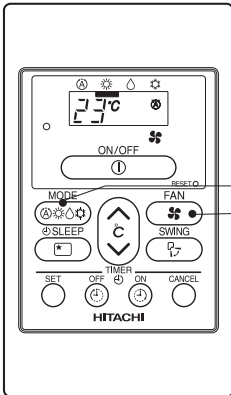

1 Press the MODE SELECTOR button so that the display indicates (HEAT).

Set the desired FAN SPEED with the (FAN SPEED) button (the display indicates the setting).

2



Set the desired room temperature with the ROOM TEMPERATURE setting button (the display indicates the setting).

3

The temperature setting and the actual room temperature may vary depending on conditions.

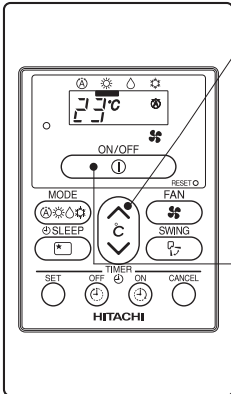

**START
STOP**

Press the (START/STOP) button. Heating operation starts. Press the button again to stop operation.

- As the settings are stored in the memory of the remote controller, you only have to press the (START/STOP) button next time.
- During AUTO fan, the fan speed automatically changes as below:
 - When the difference between room temperature and setting temperature is large, fan starts to run at HI speed.
 - After room temperature reaches the preset temperature, fan speed will be changed to lower speed to obtain optimum room temperature condition for natural healthy heating.

Defrosting

Defrosting will be performed about once an hour when frost forms on the heat exchange of the outdoor unit, for 5~10 minutes each time.

During defrosting operation, the operation lamp blinks/dimmed in a cycle of 3 seconds on and 0.5 second off. The maximum time for defrosting is 20 minutes.

However, if the indoor unit is connected to multi type outdoor unit, the maximum time for defrosting is 15 minutes.

(If the piping length used is longer than usual, frost is likely to form.)

DEHUMIDIFYING OPERATION

Use the device for dehumidifying when the room temperature is over 16°C.
When it is under 15°C, the dehumidifying function will not work.

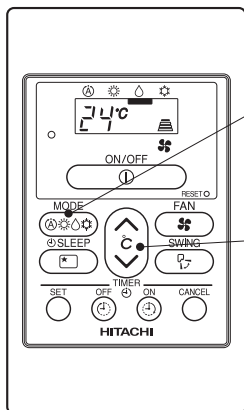

Press the MODE SELECTOR button so that the display indicates ○ (DEHUMIDIFY).
Press ♣ (FAN SPEED) button to select SILENT or LOW fan speed.

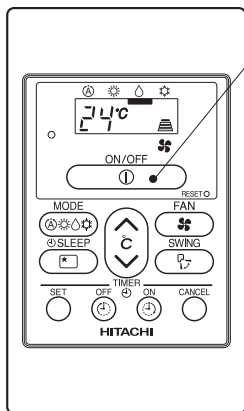

Set the desired room temperature with the ROOM TEMPERATURE setting button (the display indicates the setting).

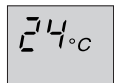

The range of 20-26°C is recommended as the room temperature for dehumidifying.

START STOP

Press the Ⓜ (START/STOP) button. Dehumidifying operation starts. Press the button again to stop operation.

- As the settings are stored in the memory in the remote controller, you only have to press the Ⓜ (START/STOP) button next time.

■ Dehumidifying Function

- When the room temperature is higher than the temperature setting: The device will dehumidify the room, reducing the room temperature to the preset level.
When the room temperature is lower than the temperature setting: Dehumidifying will be performed at the temperature setting slightly lower than the current room temperature, regardless of the temperature setting.
- The preset room temperature may not be reached depending on the number of people present in the room or other room conditions.

COOLING OPERATION

Use the device for cooling when the outdoor temperature is $-10\sim 43^{\circ}\text{C}$.
 If indoor humidity is very high (80%), some dew may form on the air outlet grille of the indoor unit.

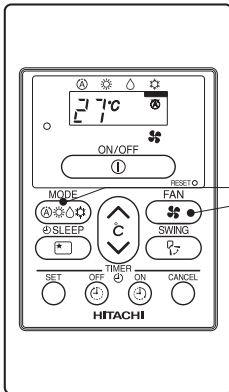

1 Press the MODE SELECTOR button so that the display indicates (COOL).

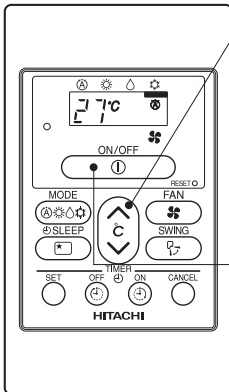

2 Set the desired FAN SPEED with the (FAN SPEED) button (the display indicates the setting).



3 Set the desired room temperature with the ROOM TEMPERATURE setting button (the display indicates the setting).
 The temperature setting and the actual room temperature may vary depending on conditions.

START STOP

Press the (START/STOP) button. Cooling operation starts. Press the button again to stop operation. The cooling function does not start if the temperature setting is higher than the current room temperature (even though the (OPERATION) lamp lights). The cooling function will start as soon as you set the temperature below the current room temperature.



- As the settings are stored in the memory of the remote controller, you only have to press the (START/STOP) button next time.
- During AUTO fan, the fan speed automatically changes as below:
 - When the difference between room temperature and setting temperature is large, fan starts to run at HI speed.
 - After room temperature reaches the preset temperature, fan speed will be changed to lower speed to obtain optimum room temperature condition for natural healthy cooling.



LEAVE HOME(LH) AND CLEAN (ONE TOUCH CLEAN) OPERATIONS

- Leave Home (LH) and CLEAN(One Touch Clean) operations activation buttons are not available on this device. The operations shall be activated by wireless remote controller.
- Please refer to wireless 'Remote Controller Manual' to activate the operations.

NOTE

- If  or  is displayed on the wired remote controller display, the unit will operate Leave Home (LH) operation mode or CLEAN (One Touch Clean) which shall be activated by wireless remote controller.
- Push start/stop  button to stop Leave Home (LH) or CLEAN (One Touch Clean) operation.



AUTO SWING OPERATION

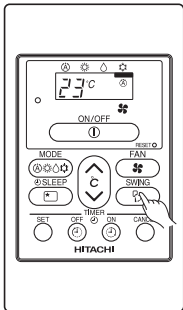

VERTICAL SWING

■ To start Vertical Auto Swing

- Press  AUTO SWING button. The deflector(s) will start to swing up and down.

■ To cancel Vertical Auto Swing

- Press  AUTO SWING button again. The deflector(s) will stop in the current position.

NOTE

- During cooling and dehumidifying operation, do not keep the deflectors swinging or in the lower position (in the case of vertical auto swing) for a long time. It may cause dew condensation on the deflectors.

TIMER RESERVATION

■ ON Timer and OFF Timer are available.

OFF Timer Reservation

1 ⏸ OFF TIMER setting

- Select the OFF TIMER by pressing the ⏸ (OFF) Button.
- Setting timer will change according to the below sequence when you press the button.

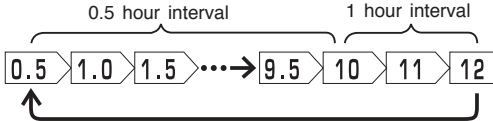

- The value change quicker if you keep pressing the button.

2 Press the ○ (SET) button

- OFF TIMER is reserved.
- The ⏸ (OFF) Mark starts lighting instead of blinking.

ON Timer Reservation

1 ⏻ ON TIMER setting

- Select the ON TIMER by pressing the ⏻ (ON) Button.
- At the beginning of setting, timer is set to 6 hours.
- Setting timer will change according to the below sequence.

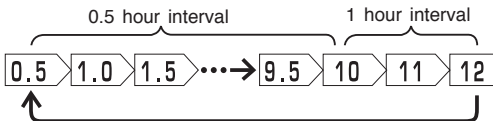

- The value change quicker if you keep pressing the button.

2 Press the ○ (SET) button

- ON TIMER is reserved.
- The 1 (ON) Mark starts lighting instead of blinking.

CANCELLATION of Timer Reservation

1 Press the ○ (CANCEL) button

- As the timer settings are stored in remote controller memory, you only have to press the ○ (SET) button in order to use the same setting next time.

■ Operation stop at setting timer

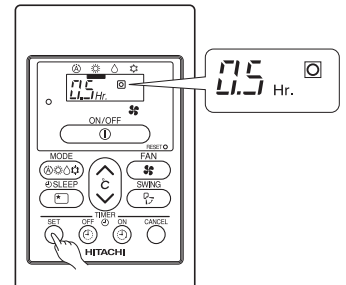
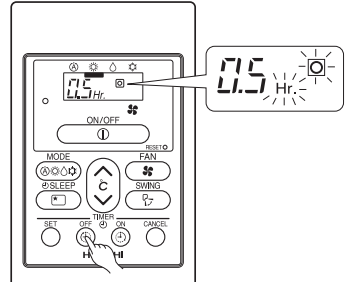

■ Operation will start for setting temperature at setting timer (The starting time may different depend on the room temperature and set temperature).

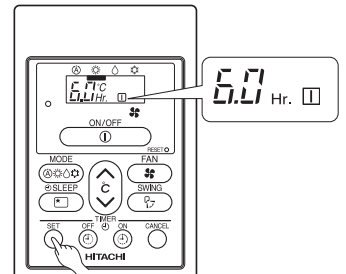
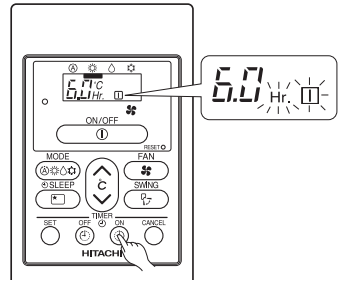

HOW TO SET THE SLEEP TIMER

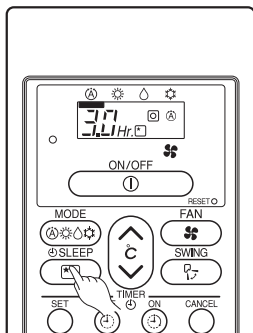

Example: Setting 3 hours sleep timer.

Mode	Indication
Sleep timer	→ 1 hour → 2 hours → 3 hours → 7 hours Sleep timer off ←

Sleep Timer: The device will continue working for the designated number of hours and then turn off.
Press the SLEEP button.
The timer information will be displayed on the remote controller.

How to Cancel Reservation

Press the ○ (CANCEL) button. The ◻ and * (RESERVED) sign goes out.

Explanation of the sleep timer

The device will control the FAN SPEED and room temperature automatically so as to be quiet and good for people's health.

NOTE

- If you set the sleep timer after the off or on-timer has been set, the sleep timer becomes effective instead of the off or on-timer set earlier.
- You can not set other timer during sleep timer operation.
- After sleep timer time is up and when press sleep button again, the sleep timer will be set as last setting.
- Sleep timer effective only once.

INSTALLATION OF WIRED REMOTE CONTROLLER

- (a) Connection to the electrical box;
 - Remove the cover of electric box
 - Connect the connector of wired remote controller to CN1102 of electrical board
 - Assemble back the cover of electrical box
- (b) Wiring installation for wired remote controller (2 methods);
 - Wired remote controller casing can be opened by pressing the slots with minus screw driver (see below diagram)

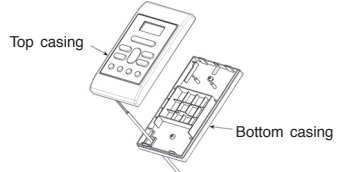
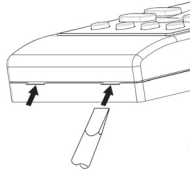

- Decide the fixing location of remote controller so that the length of wire shall be within 5 meters.



- Do not cut the provided wire. Excess wire should be properly wound and fitted at safe place.
- Do not join the wire with additional wire.

Wiring installation illustrations

Wall recessed wiring installation (Supplied)

1. When connecting the wires via the wall's recessed slot;
 - Fix the bottom casing to the wall by provided screw.
 - Assemble the top casing to the fixed bottom casing. (Refer to the illustration below for detail installation)

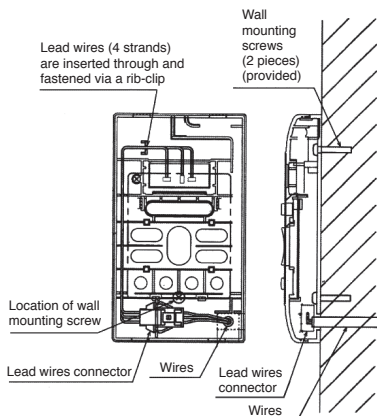

Inside top wiring installation (Alternative)

2. When the wires to be connected from the inside top portion of top casing;
 - Break off a perforated aperture located at the top portion of the bottom casing by nipper. Smoothen the aperture by cutter.
 - Fix the bottom casing to the wall by provided screw.
 - Connect the wires to the lead wires connector.
 - Mount the wires through the provided slot on top casing.
 - Assemble the top casing to the fixed bottom casing (Refer to the illustration below for detail installation)

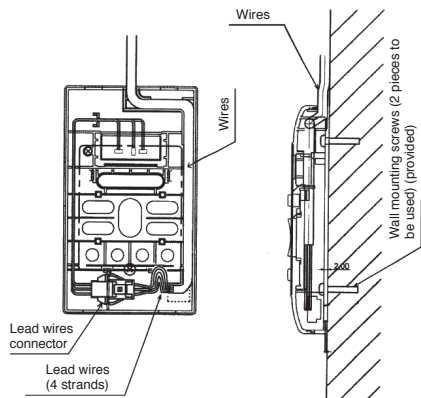

Remote Controller Manual

**MODEL
SPX-RCKA2
(RAR-6N1)**

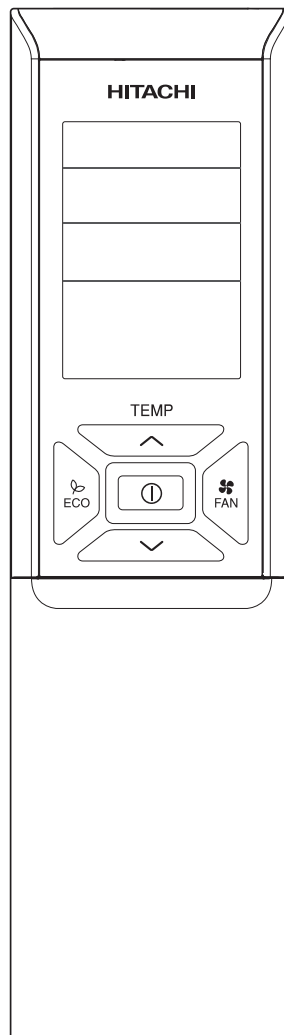

PREPARATION BEFORE OPERATION

■ To install the batteries

1. Slide the cover to take it off.
2. Install two dry batteries AAA.LR03 (alkaline).
The direction of the batteries should match the marks in the case.
3. Replace the cover at its original position.

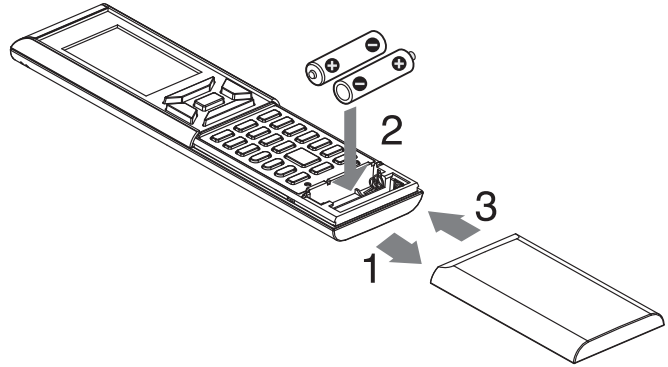

■ To fix the remote controller holder to the wall

1. Choose a place from where the signals can reach the unit.
2. Fix the remote controller holder to a wall, a pillar or similar location with the provided screws.
3. Place the remote controller in the remote controller holder.

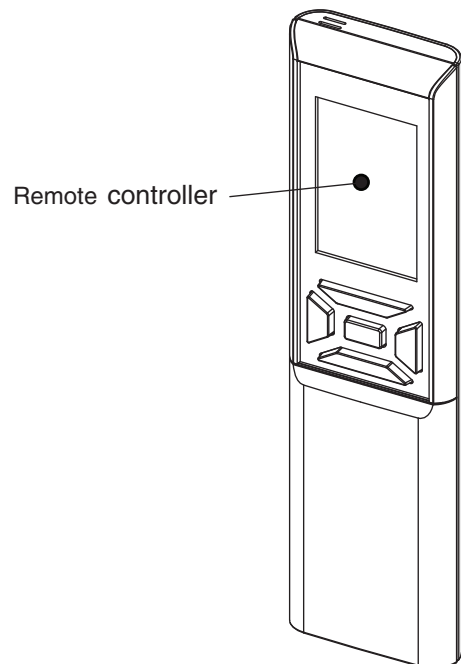

NOTE

Notes on batteries

- When replacing the batteries, use batteries of the same type, and replace both old batteries together.
- When the system is not used for a long time, take the batteries out.
- The batteries will last for approximately 1 year. However, if the remote controller display begins to fade and degradation of reception performance occurs within a year, replace both batteries with new size AAA.LR03 (alkaline).
- The attached batteries are provided for the initial use of the system.
The usable period of the batteries may be short depending on the manufactured date of the air conditioner.

Notes on the remote controller

- Never expose the remote controller to direct sunlight.
- Dust on the signal transmitter or receiver will reduce the sensitivity. Wipe off dust with soft cloth.
- Signal communication may be disabled if an electronic-starter-type fluorescent lamp (such as inverter-type lamps) is in the room. Consult the shop if that is the case.
- If the remote controller signals happen to operate another appliance, move that appliance to somewhere else, or consult the service shop.
- When the remote controller is not in use, please close the slide cover to prevent failure.

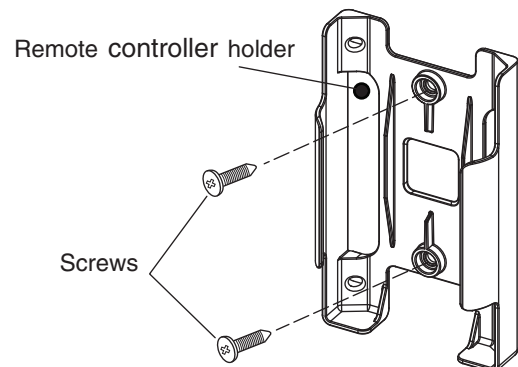

PREPARATION BEFORE OPERATION

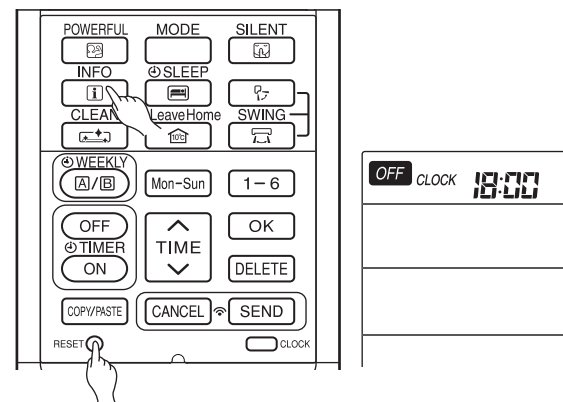
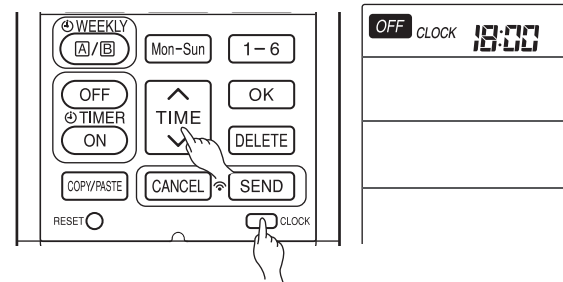
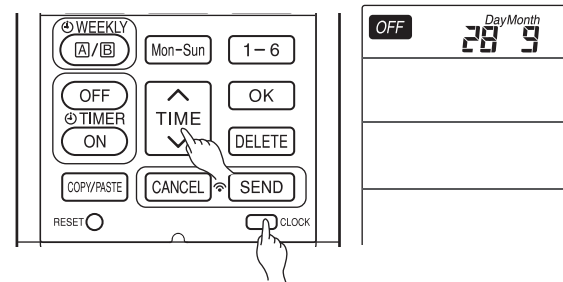
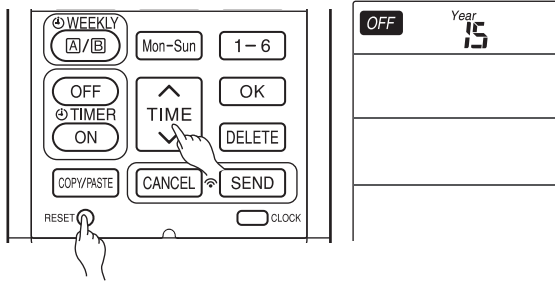

To set calendar and clock

1. Press **RESET** (RESET) button when first time setting. "Year" blinks.
2. Press **TIME** (TIME) button to set the current year.
3. Press **CLOCK** (CLOCK) button. "Day" and "Month" blink.
4. Press **TIME** (TIME) button to set the current day and month.
5. Press **CLOCK** (CLOCK) button. "CLOCK" blinks.
6. Press **TIME** (TIME) button to set the clock to the current time.
7. Press **CLOCK** (CLOCK) button.
Calendar and clock are set.

To modify the calendar and clock, press **CLOCK** (CLOCK) button.

Then follow steps 1 to 7.

Calendar and clock need to be set again after changing batteries.

After changing the batteries,

1. Press **RESET** (RESET) button.
2. Direct remote controller towards indoor unit and press **INFO** (INFO) button.
3. The calendar and clock from indoor unit will be transmitted.

Calendar and clock will not be transmitted from indoor unit when the following occurs:

- When there is a power failure.
- When breaker is OFF by user (unit is not in STANDBY MODE).

NOTE

Note on setting the calendar and clock.

- If the calendar and clock are not set, the ON-timer, OFF-timer and Weekly Timer cannot be set.
- If the calendar and clock are not set correctly, the ON-timer, OFF-timer and Weekly Timer will not operate correctly.
- When the ON-timer, OFF-timer and Weekly Timer are set, the calendar and clock cannot be changed. If there is a need to change the calendar and clock, ON-timer, OFF-timer and Weekly Timer need to be cancelled.

NAMES AND FUNCTIONS OF REMOTE CONTROLLER

REMOTE CONTROLLER

- This controls the operation of the indoor unit. The range of control is about 7 meters. If indoor lighting is controlled electronically, the range of control may be shorter.
This unit can be fixed on a wall using the fixture provided. Before fixing it, make sure the indoor unit can be controlled from the remote controller.
- Handle the remote controller with care. Dropping it or getting it wet may compromise its signal transmission capability.
- After new batteries are inserted into the remote controller, the unit will initially require approximately 10 seconds to respond to commands and operate.
- When remote controller is not in use for about 3 minutes during OFF condition, indicated by **OFF** on the display, the LCD will turn off.
- During clock setting, the LCD will turn off about 10 minutes later if the remote controller is not in use.
- When pressing any button, the LCD will turn on.
- The LCD will not turn off during TIMER setting.

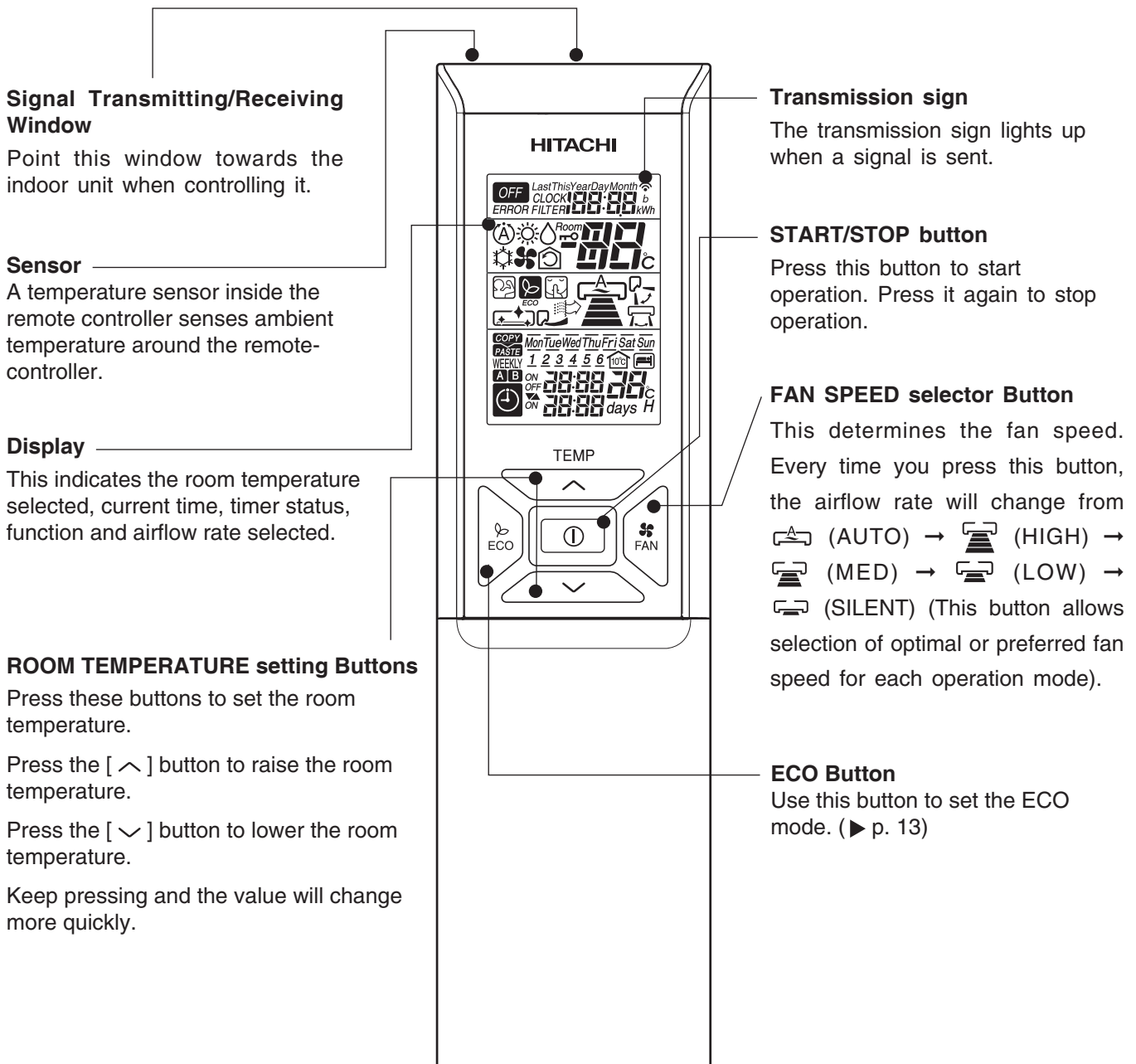

NAMES AND FUNCTIONS OF REMOTE CONTROLLER

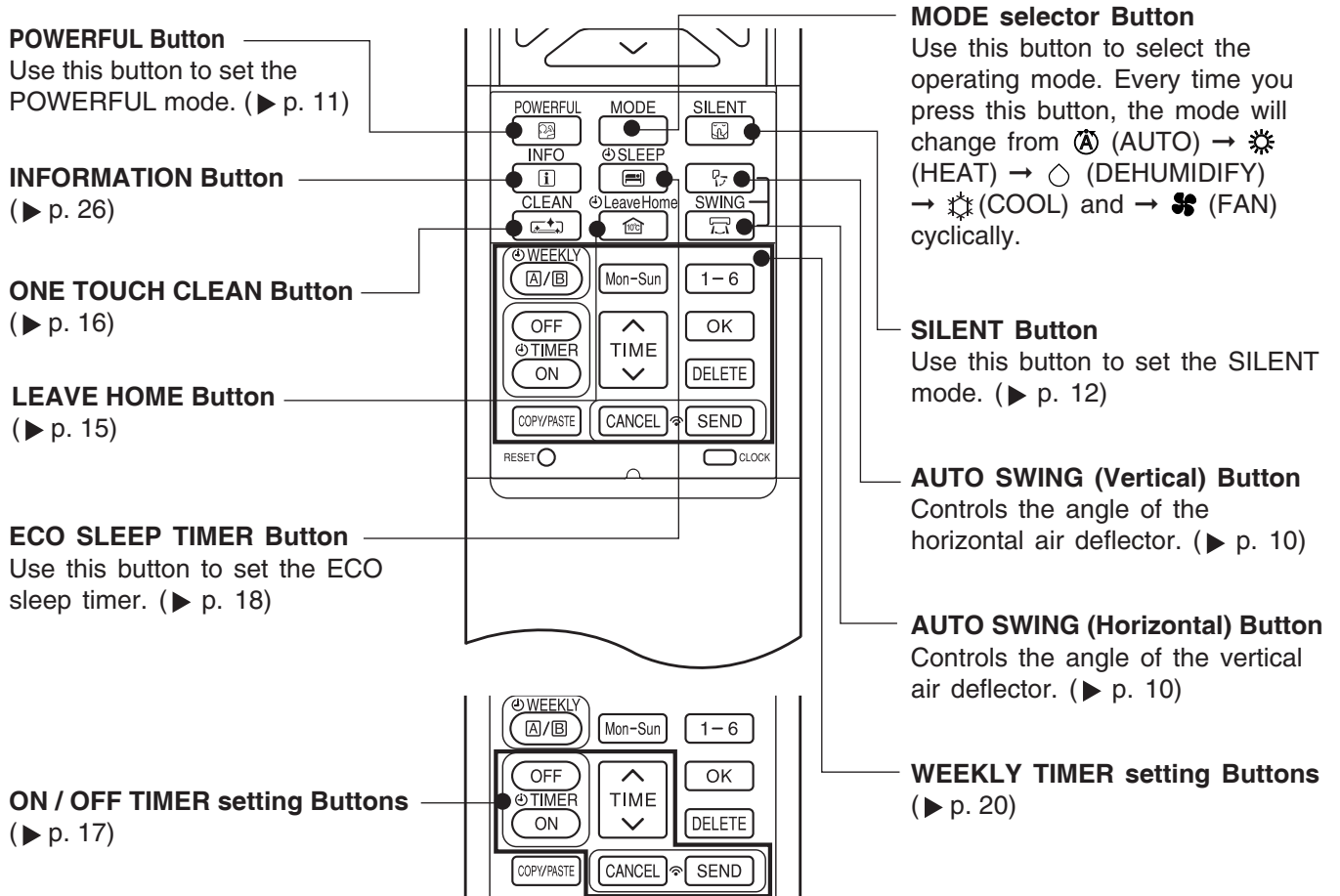

MODE	MODE SELECTOR
Ⓐ	AUTO
☀	HEAT
◊	DEHUMIDIFY
❄	COOL
🌀	FAN
Ⓐ	FAN SPEED
	AUTO
	SILENT
	LOW
	MED
	HIGH
ⓘ	START / STOP
ECO	ECO

🌀	FAN
☀	POWERFUL
🔇	SILENT
ⓘ	INFO
🌙	SLEEP TIMER
🌀	AUTO SWING (VERTICAL)
🌀	AUTO SWING (HORIZONTAL)
🏠	LEAVE HOME
↔	CLEAN
Mon-Sun	DAY
1-6	PROGRAM NO.

OFF	ON / OFF TIMER
⏰	ON / OFF TIMER
ON	ON / OFF TIMER
⬆	TIME
TIME	TIME
⬆	TIME
OK	OK
DELETE	DELETE
DELETE	DELETE
COPY/PASTE	COPY / PASTE
COPY/PASTE	COPY / PASTE
CANCEL	CANCEL
CANCEL	CANCEL
SEND	SEND
SEND	SEND
CLOCK	CLOCK
CLOCK	CLOCK

Precautions for Use

- Do not put the remote controller in the following places.
 - Under direct sunlight.
 - In the vicinity of a heater.
- Handle the remote controller carefully. Do not drop it on the floor, and protect it from water.
- Once the outdoor unit stops, it will not restart for about 3 minutes (unless you turn the power switch off and on or unplug the power cord and plug it in again). This is to protect the device and does not indicate a failure.
- If you press the MODE selector button during operation, the device may stop for about 3 minutes for protection.

VARIOUS FUNCTIONS

Auto Restart Control

- If there is a power failure, operation will be automatically restarted when the power is resumed with previous operation mode and airflow direction.
(As the operation is not stopped by remote controller.)
- If you intend not to continue the operation when the power is resumed, switch off the power supply.
When you switch on the circuit breaker, the operation will be automatically restarted with previous operation mode and airflow direction.

Note: 1. If you do not require Auto Restart Control, please consult your sales agent.
2. Auto Restart Control is not available when Timer or Sleep Timer mode is set.

AUTOMATIC OPERATION

The device will automatically determine the mode of operation, HEAT or COOL depending on the current room temperature. The selected mode of operation will change when the room temperature varies. However, the mode of operation will not change when indoor unit is connected to multi type outdoor unit.

1 Press the MODE selector button so that the display indicates the (AUTO) mode of operation.

- When AUTO has been selected, the device will automatically determine the mode of operation, HEAT or COOL depending on the current room temperature. However the mode of operation will not change when indoor unit is connected to multi type outdoor unit.
- If the mode automatically selected by the unit is not satisfactory, manually change the mode setting (HEAT, DEHUMIDIFY, COOL or FAN).

2 Set the desired FAN SPEED with the (FAN SPEED) button (the display indicates the setting).

→ (AUTO) → (HIGH) → (MED) → (LOW) → (SILENT) →

3 Set the desired room temperature with the TEMPERATURE buttons (the display indicates the setting).
The temperature setting and the actual room temperature may vary depending on conditions.
Temperature range can be set between 16°C and 32°C.

START STOP Press the (START/STOP) button.
Operation starts with a beep.
Press the button again to stop operation.

- As the settings are stored in the memory of the remote controller, you only have to press the (START/STOP) button next time.

Press the (FAN SPEED) button to select AUTO, HIGH, MED, LOW or SILENT.

HEATING OPERATION

- Use the device for heating when the outdoor temperature is under 21°C. When it is too warm (over 21°C), the heating function may not work in order to protect the device.
- In order to maintain reliability of the device, please use this device when outdoor temperature is above -15°C.

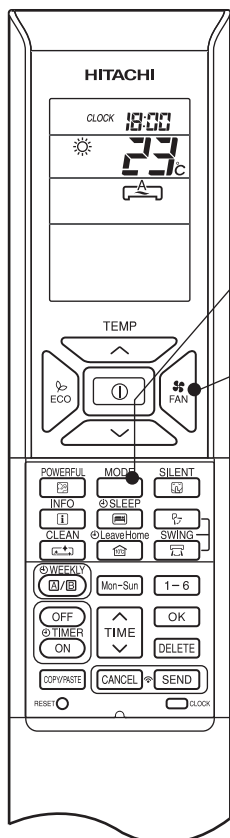

1

Press the MODE selector button so that the display indicates ☀ (HEAT).

2

Set the desired FAN SPEED with the  (FAN SPEED) button (the display indicates the setting).

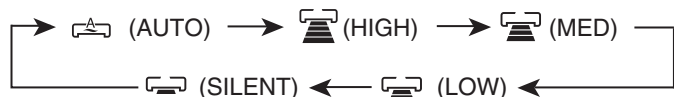

3

Set the desired room temperature with the TEMPERATURE buttons (the display indicates the setting).

The temperature setting and the actual room temperature may vary depending on conditions.

Temperature range can be set between 16°C and 32°C.

START STOP

Press the  (START/STOP) button. Heating operation starts with a beep. Press the button again to stop operation.

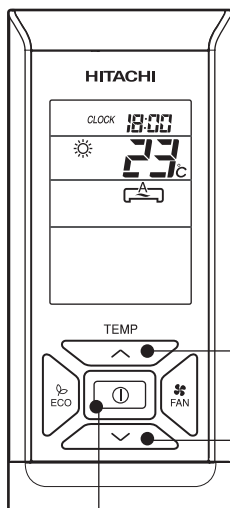

- As the settings are stored in the memory of the remote controller, you only have to press the  (START/STOP) button next time.
- During AUTO fan, the fan speed automatically changes as below:
 - When the difference between room temperature and setting temperature is large, fan starts to run at HI speed.
 - After room temperature reaches the preset temperature, fan speed will be changed to lower speed to obtain optimum room temperature condition for natural healthy heating.

Defrosting

Defrosting will be performed about once an hour when frost forms on the heat exchange of the outdoor unit, for 5~10 minutes each time.

During defrosting operation, the operation lamp blinks/dimmed in a cycle of 3 seconds on and 0.5 second off. The maximum time for defrosting is 20 minutes.

However, if the indoor unit is connected to multi type outdoor unit, the maximum time for defrosting is 15 minutes.



(If the piping length used is longer than usual, frost is likely to form.)

DEHUMIDIFYING OPERATION

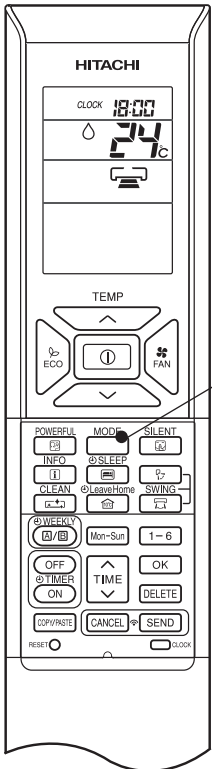
Use the device for dehumidifying when the room temperature is over 16°C.
When it is under 15°C, the dehumidifying function will not work.



1

Press the MODE selector button so that the display indicates  (DEHUMIDIFY).
The fan speed is set at LOW.
Press  (FAN SPEED) button to select SILENT or LOW fan speed.

2

Set the desired room temperature with the ROOM TEMPERATURE setting buttons (the display indicates the setting).

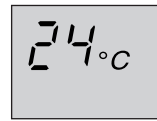

The range of 20-26°C is recommended as the room temperature for dehumidifying.
Temperature range can be set between 16°C and 32°C.

**START
STOP**

Press the  (START/STOP) button. Dehumidifying operation starts with a beep. Press the button again to stop operation.

- As the settings are stored in the memory of the remote controller, you only have to press the  (START/STOP) button next time.

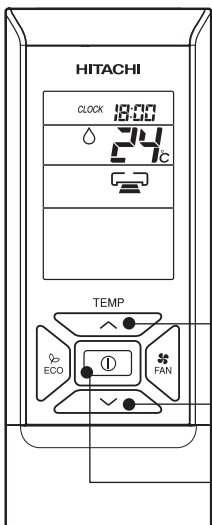



■ Dehumidifying Function

- When the room temperature is higher than the temperature setting: The device will dehumidify the room, reducing the room temperature to the preset level.
When the room temperature is lower than the temperature setting: Dehumidifying will be performed at the temperature setting slightly lower than the current room temperature, regardless of the temperature setting.
- The preset room temperature may not be reached depending on the number of people present in the room or other room conditions.

COOLING OPERATION

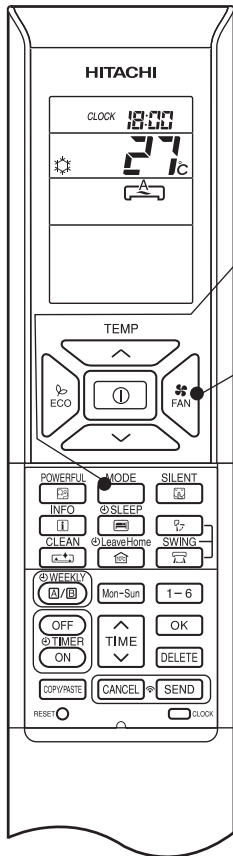
Use the device for cooling when the outdoor temperature is -10~43°C.
If indoors humidity is very high (80%), some dew may form on the air outlet grille of the indoor unit.





1 Press the MODE selector button so that the display indicates  (COOL).

2 Set the desired FAN SPEED with the  (FAN SPEED) button (the display indicates the setting).



3 Set the desired room temperature with the TEMPERATURE buttons (the display indicates the setting).
The temperature setting and the actual room temperature may vary depending on conditions.
Temperature range can be set between 16°C and 32°C

START STOP

Press the  (START/STOP) button. Cooling operation starts with a beep. Press the button again to stop operation. The cooling function does not start if the temperature setting is higher than the current room temperature (even though the  (OPERATION) lamp lights). The cooling function will start as soon as user set the temperature below the current room temperature.

- As the settings are stored in the memory of the remote controller, you only have to press the  (START/STOP) button next time.
- During AUTO fan, the fan speed automatically changes as below:
 - When the difference between room temperature and setting temperature is large, fan starts to run at HI speed.
 - After room temperature reaches the preset temperature, fan speed will be changed to lower speed to obtain optimum room temperature condition for natural healthy cooling.

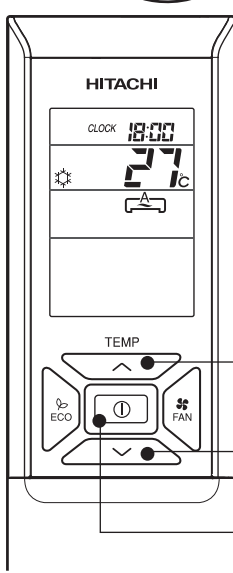

FAN OPERATION

User can use the device simply as an air circulator.

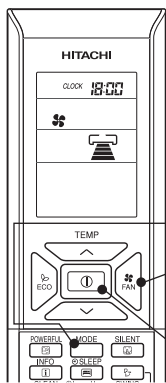

1

Press the MODE selector so that the display indicates  (FAN).

2

Set the desired FAN SPEED with the  (FAN SPEED) button (the display indicates the setting).



**START
STOP**

Press the  (START/STOP) button. Fan operation starts with a beep. Press the button again to stop operation.



AUTO SWING OPERATION

VERTICAL SWING

■ To start Vertical Auto Swing



- Press  (AUTO SWING (VERTICAL)) button. The deflector(s) will start to swing up and down.
 is displayed on the LCD.

■ To cancel Vertical Auto Swing



- Press  (AUTO SWING (VERTICAL)) button again. The deflector(s) will stop in the current position.
 disappeared from the LCD.

HORIZONTAL SWING

■ To start Horizontal Auto Swing

- Press  (AUTO SWING (HORIZONTAL)) button. The deflectors will start to swing right and left.
 is displayed on the LCD.

■ To cancel Horizontal Auto Swing

- Press  (AUTO SWING (HORIZONTAL)) button again. The deflectors will stop in the current position.
 disappeared from the LCD.

NOTE

- During cooling and dehumidifying operation, do not keep the deflectors swinging or in the lower position (in the case of vertical auto swing) for a long time. It may cause dew condensation on the deflectors.



POWERFUL OPERATION

- By pressing  (POWERFUL) button during AUTO, HEATING, DEHUMIDIFYING, COOLING or FAN operation, the air conditioner performs at the maximum power.
- During POWERFUL operation, cooler or warmer air will be blown out from indoor unit for COOLING or HEATING operation respectively.

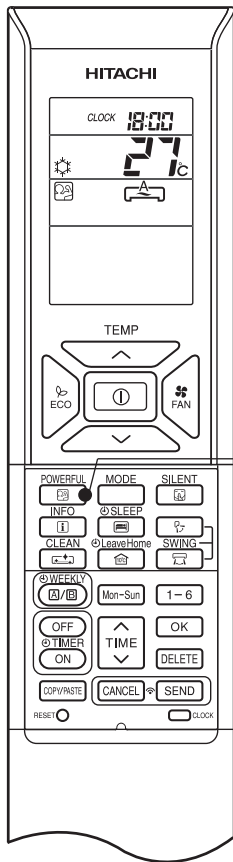



■ To start POWERFUL operation

- Press  (POWERFUL) button during operation.

“” is displayed on the LCD.

POWERFUL operation ends in 20 minutes. Then the system automatically operates with the previous settings used before POWERFUL operation.

■ To cancel POWERFUL operation

- Press the  (START/STOP) button. Or
- Press  (POWERFUL) button again.

POWERFUL operation stops.

“” disappears from the LCD.

NOTE

- When SLEEP mode, ECO mode, SILENT mode or LEAVE HOME mode is selected, POWERFUL operation is cancelled.
- During POWERFUL operation, capacity of the air conditioner will not increase
 - if the air conditioner is already running at maximum capacity.
 - just before defrost operation (when the air conditioner is running in HEATING operation).
- After auto restart, POWERFUL operation is cancelled and previous operation shall start.
- For multi model connections, POWERFUL operation may not function depending on operation conditions.

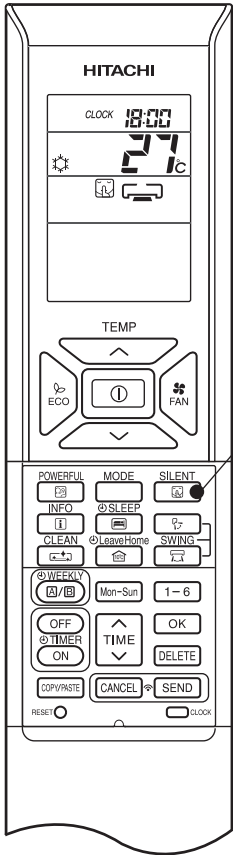

SILENT OPERATION

- By pressing  (SILENT) button during AUTO, HEATING, DEHUMIDIFYING, COOLING or FAN operation, the fan speed will change to ultra slow.





■ To start SILENT operation

1

- Press  (SILENT) button during operation.
“” is displayed on the LCD. Fan speed will be ultra slow.

■ To cancel SILENT operation



- Press  (START/STOP) button. Or
- Press  (SILENT) button again or  (FAN SPEED) button.

Fan speed will return to previous fan speed before SILENT operation starts.

SILENT operation stops.

“” disappears from the LCD.

NOTE

- When POWERFUL operation is selected, SILENT operation is cancelled. Fan speed will return to previous fan speed before SILENT operation.
- After auto restart, SILENT operation is cancelled. Fan speed will return to previous fan speed before SILENT operation.
- During any operation with fan speed , if press  (SILENT) button, fan speed will not change.



ECO OPERATION

There are two kinds of ECO OPERATION with sensor or without sensor, depending on models. Please refer to [Names and Functions of each part] in the unit instruction manual to verify if your unit is equipped with a sensor and read the following instruction on ECO Operation accordingly.

■ ECO OPERATION

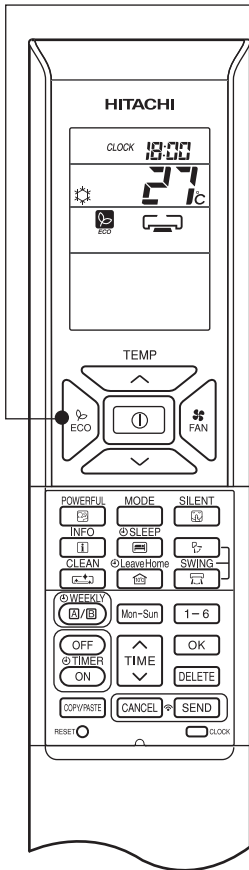

ECO operation is an energy saving function by changing set temperature automatically and by limiting the maximum power consumption value.



1

- By pressing the  (ECO) button during AUTO, HEATING, DEHUMIDIFYING or COOLING operation, the air conditioner performs the "ECO" operation.



■ To start ECO operation

- Press  (ECO) button during operation.
- “” is displayed on the LCD.

A beep sound is emitted from indoor unit.

Energy saving operation will start by changing the set temperature higher or lower automatically and reducing operation power consumption. This function may vary based on the connected outdoor unit.

■ To cancel ECO operation

- Press  (START/STOP) button. Or
- Press  (ECO) button again.

“” disappears from the LCD.

A beep sound is emitted from indoor unit.

NOTE

- ECO function will not be effective when power consumption is low.
- By pressing (POWERFUL) button, ECO operation is cancelled.
- After auto restart, ECO operation is cancelled and previous operation mode shall start.
- For multi model connections, energy saving operation shall start only by changing set temperature higher or lower automatically. However, effectiveness of ECO depends on operation conditions.



ECO OPERATION with sensor

The sensor detects the presence of people in the room. When nobody is detected, the unit automatically starts energy saving operation by shifting the set temperature in two steps.

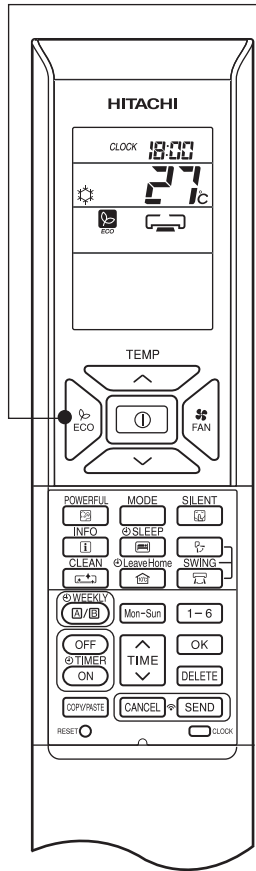

- 1**
- By pressing the (ECO) button during AUTO, HEATING, DEHUMIDIFYING or COOLING operation, the air conditioner performs the "ECO" operation.

To start ECO operation

- Press (ECO) button during operation.
 - is displayed on the LCD.
 - A beep sound is emitted from indoor unit and the (ECO) lamp on the indoor unit lights up.
 - The sensor starts to detect the presence of people in the room.

To cancel ECO operation

- Press (START/STOP) button. Or
- Press (ECO) button again.
 - disappears from the LCD.
 - A beep sound is emitted from indoor unit and the (ECO) lamp on the indoor unit turns off.

When the presence of people is not detected for 20 minutes, the set temperature is automatically shifted for energy saving. If nobody is in the room for 60 minutes, the set temperature is shifted further.

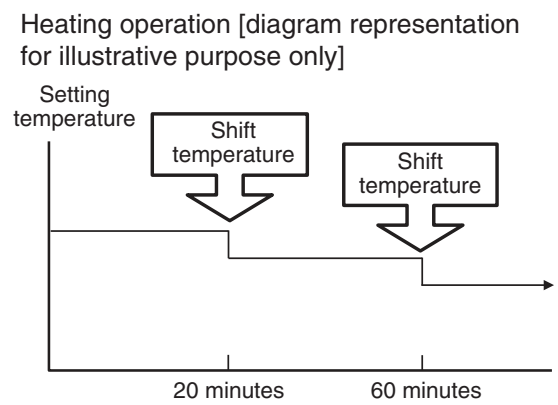
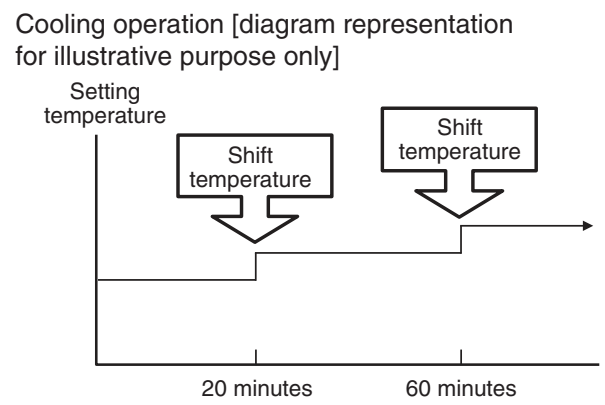

The unit returns to normal operation when the sensor detects human movement.

NOTE

- By pressing (POWERFUL) button, ECO operation is cancelled.
- After auto restart, ECO operation is cancelled and previous operation mode shall start.

10°C LEAVE HOME (LH) OPERATION

Prevent the room temperature from falling too much when no one is at home. The initial setting temperature is 10°C and the temperature range can be set between 10°C and 16°C.

This operation is able to operate by "Continuous operation" or "Day timer operation". Please use "Day timer operation" to set the number of days up to 99 days.

Continuous operation

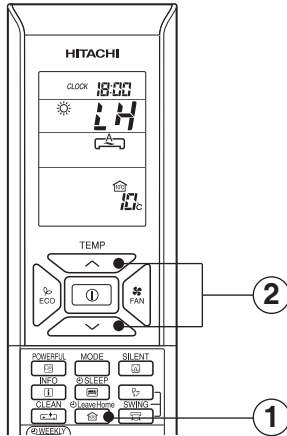

Day timer operation

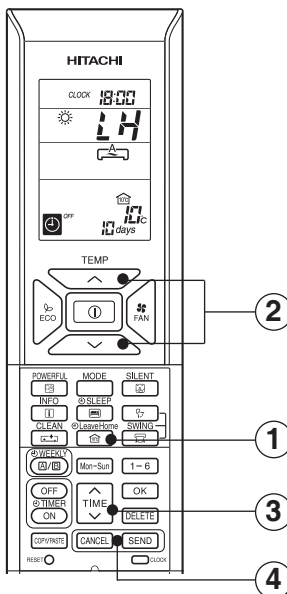

To start LEAVE HOME operation

Option 1. Continuous operation.

- ① Press (LEAVE HOME) button during stop or operation. Room temperature is set at 10°C and heating operation starts.
- ② Set the desired room temperature with the TEMPERATURE buttons. Temperature range can be set between 10°C and 16°C.
 "☀️", "LH", "A", "10°C", "SET TEMPERATURE" is displayed on the LCD.

Option 2. Day timer operation.

- ① Press (LEAVE HOME) button during stop or operation. Room temperature is set at 10°C and heating operation starts.
- ② Set the desired room temperature with the TEMPERATURE buttons. Temperature range can be set between 10°C and 16°C.
 "☀️", "LH", "A", "10°C", "SET TEMPERATURE" is displayed on the LCD.
- ③ Set number of operation days (1 to 99 days), if needed.
 Press (TIME) button to select number of days.
 Number of days blink.
 * Press "▲ (UP)" or "▼ (DOWN)" to set number of days from 1 day to 99 days.
 * Number of day is counted when clock indicates 0:00.
- ④ Press (SEND) button to confirm number of operation days. Display for number of operation days will stop blinking.
 Press (CANCEL) button to reset number of operation days or to have continuous operation.

To cancel LEAVE HOME operation

- Press (START/STOP) button. Or
- Press (LEAVE HOME) button again. Return to previous operation mode. Or
- Change to other operation mode by pressing (MODE) button.

NOTE

- After reaching the set number of operation days for Leave Home or by pressing the (Leave Home) button again, the unit will operate in previous mode.
- During Leave Home operation, fan speed and horizontal air deflector position cannot be changed.
- By pressing (Leave Home) button, implementation of Weekly Timer or Once Timer is cancelled.
- In case of power supply shut down, after autorestart, all setting for number of days operation will be reset and unit shall be in continuous operation.
- POWERFUL, SILENT and ECO operations are not applicable during Leave Home operation.
- For multi connection
 - FAN/COOLING/DEHUMIDIFYING and Leave Home cannot operate at the same time. The first-run unit has a priority and other units in different mode will be in standby mode.
 - Heating operation can be used with Leave Home.
 - When two or more rooms are set to operate Leave Home, the temperature set by Leave Home may not be reached. It also depends on outdoor temperature.



CLEAN (ONE TOUCH CLEAN) OPERATION

Drying indoor heat exchanger after cooling operation to prevent mildew.

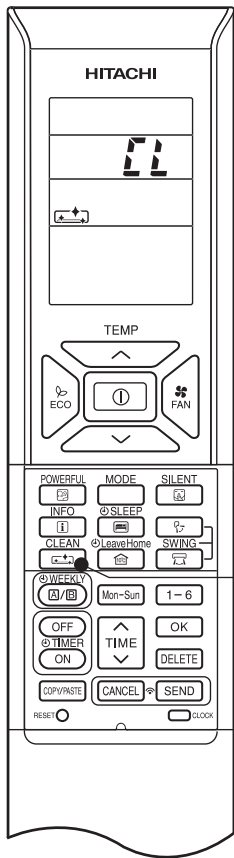



■ To start CLEAN operation

- Press  (CLEAN) button when unit is OFF.
Total time taken for One Touch Clean operation is 60 minutes.
During this operation, HEATING or FAN operation shall operate.
During one touch clean, operation lamp is blinking.

“”, “” is displayed on the LCD.

■ To cancel CLEAN operation

- Press  (START/STOP) button. Or
- Press  (CLEAN) button again.

NOTE

- When CLEAN operation finish, unit will switch OFF automatically.
- If Weekly Timer or Once Timer is set, there is a need to cancel those timer before operating CLEAN function.



ONCE TIMER (ON/OFF TIMER) OPERATION

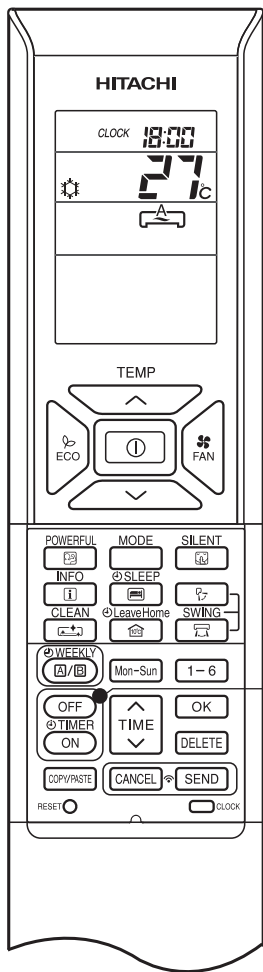

OFF TIMER

The device can be set to turn off at a preset time.

1. Press (OFF-TIMER) button. and **0:00** blink on the display.
2. Set the "turn-off time" with (TIME) button.
3. After setting, direct the remote controller towards the indoor and press (SEND) button.

and "set time" lights up instead of blinking.

A beep sound emitted from indoor unit and the (TIMER) lamp on the indoor unit lights up.

ON TIMER

The device will turn on at a designated time.

1. Press (ON-TIMER) button. and **6:00** blink on the display.
2. Set the "turn-on time" with (TIME) button.
3. After setting, direct the remote controller towards the indoor and press (SEND) button.

and "set time" light up instead of blinking.

A beep sound emitted from indoor unit and the (TIMER) lamp on the indoor unit lights up.

ON/OFF TIMER

- The device will turn on (off) and off (on) at the designated time.
- The switching occurs first at the preset time that comes earlier.
- The arrow mark appears on the display to indicate the sequence of switching operations.

1. Press (OFF-TIMER) button so that and **0:00** blink on the display.
2. Set the "turn-off" time with (TIME) button. After setting, direct the remote controller towards the indoor and press (SEND) button.
3. Press (ON-TIMER) button so that and set "turn-off" time light up. The and **6:00** blink.
4. Set the "turn-on" time with (TIME) button.
5. After setting, direct the remote controller towards the indoor and press (SEND) button

and set "turn-on" time light up instead of blinking.

A beep sound emitted from indoor unit and the (TIMER) lamp on the indoor unit lights up.

- The timer may be used in three ways: OFF-timer, ON-timer and ON/OFF (OFF/ON)-timer. Set the current time first because it serves as a reference.

■ To cancel Reservation

- Point the signal window of the remote controller towards the indoor unit and press (CANCEL) button. and "ON or OFF set time" goes out with a beep and the (TIMER) lamp on the indoor unit turns off.

NOTE

- User can set only one of the OFF-timer, ON-timer or ON/OFF-timer.
- If WEEKLY TIMER already set, by setting the ONCE TIMER, ONCE TIMER operation is prioritized. When ONCE TIMER operation is complete, WEEKLY TIMER operation will be activated.



ECO SLEEP TIMER OPERATION

The timer can be set up to a duration of 7 hours.

By pressing (SLEEP) button during AUTO, HEATING, DEHUMIDIFYING, COOLING or FAN operation, the unit shifts the room temperature and reduces the fan speed. It results in energy saving.

Set the current time first before operating the ECO SLEEP TIMER operation.

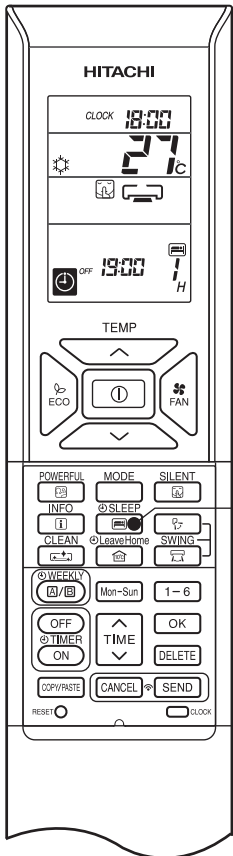

To start ECO SLEEP TIMER operation

Press (SLEEP) button during operation.

- “”, “”, “”, “OFF”, off time, “” and number of hour are displayed on the remote controller display.
- During ECO SLEEP TIMER operation, fan speed will be ultra slow.
- A beep sound emitted from indoor unit and the (TIMER) lamp on the indoor unit lights up.

Pressing (SLEEP) button repeatedly, the number of hours will change as below:

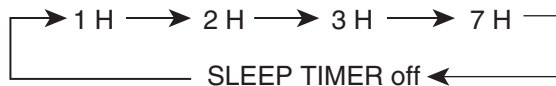

- During ECO SLEEP TIMER operation, air conditioner will continue to operate for the designated number of hours and then turn off.
- When the ECO SLEEP TIMER has been set, the display on the remote controller indicates the turn off time.



Example: If ECO SLEEP TIMER is set for 1 hour at 18:00, the switch off time will be at 19:00.

To cancel ECO SLEEP TIMER operation

Press (START/STOP) button.

- Room air conditioner will switch off.

Press (SLEEP) button again until “”, “”, “”, off time, “” and number of hour disappear from the remote controller display.

Press (CANCEL) button.

- A beep sound emitted from indoor unit and the (TIMER) lamp on the indoor unit turns off.
- SLEEP TIMER operation is cancelled.



ECO SLEEP TIMER OPERATION

To set ECO SLEEP TIMER and ON TIMER

The air conditioner will be turned off by ECO SLEEP TIMER and turned on by ON TIMER.

1. Set the ON TIMER.
2. Press (SLEEP) button and set ECO SLEEP TIMER.



Example:
In this case, air conditioner will turn off in 2 hours (at 1:38) and it will be turned on at 6:00 the next morning.

To cancel ECO SLEEP TIMER and ON TIMER operation

Direct the remote controller towards the indoor unit and press (CANCEL) button.

- “”, “”, “”, “OFF”, off time, “”, number of hour, "ON" and ON TIMER set time disappear from the remote controller display.
- A beep sound emitted from indoor unit and the (TIMER) lamp on the indoor unit turns off.
- ECO SLEEP TIMER and ON TIMER reservations are cancelled.

30 minutes after setting ECO SLEEP TIMER, outdoor fan speed will be reduced to lower the noise level and to have comfort operation.

1 hour after setting ECO SLEEP TIMER, set temperature will be slightly shifted. Amount of temperature shifted depends on type of air conditioner.

These automatic operation changes contribute to energy saving without losing comfort.

The level of energy consumption depends on outside temperature, room temperature, set temperature or air conditioner type.

Cooling operation [diagram representation for illustrative purpose only]

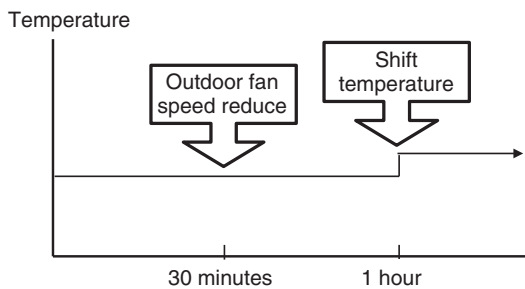

Heating operation [diagram representation for illustrative purpose only]

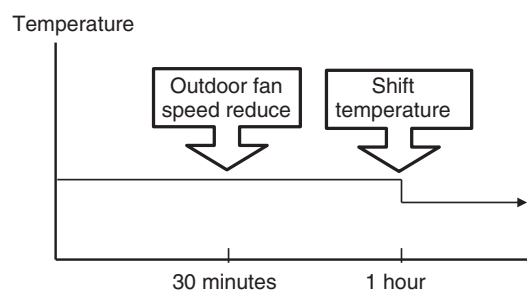

NOTE

- If ECO SLEEP TIMER is set when OFF TIMER or ON/OFF TIMER has been set earlier, the ECO SLEEP TIMER becomes effective instead of the OFF TIMER or ON/OFF TIMER.

- It is possible to select Mode A or Mode B. For each mode, up to 6 programs can be set per day. In total, a maximum of 42 programs can be set for a week for each mode.
- If calendar and clock are not set, the reservation setting for WEEKLY TIMER cannot be set.
- If calendar and clock are not set correctly, WEEKLY TIMER will not operate correctly.
- Reservation for calendar and clock shall be set first before operating WEEKLY TIMER.

Step 1: Set the reservation schedule to the remote controller. Send the registered reservation to indoor unit and then operate.

Step 2: Select Mode A or Mode B and activate or deactivate WEEKLY TIMER .

Step 3: Copy and cancel the reservation schedule.

Step 1 : Set reservation schedule to the remote controller. Send the registered reservation to indoor unit and then operate.

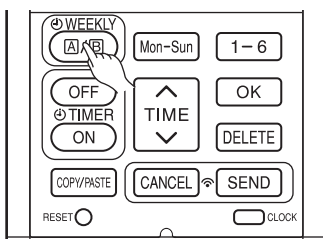

1

How to set a WEEKLY TIMER.

1. Select Mode A or Mode B

Press **WEEKLY** (WEEKLY) button. WEEKLY lights up. **A** and **🕒** blink on the display. (Mode A is selected).

Press **WEEKLY** (WEEKLY) button again, **B** and **🕒** blink on the display. (Mode B is selected).

- If no reservation has been made, ON/OFF, --:-- , **🕒** appear.
- If reservation has been made, ON/OFF, --:-- , **🕒** will not appear.

2

2. Set a program

Press **WEEKLY** (WEEKLY) button for about 3 seconds. The selection mode can be changed.

🕒, day: Mon, program no. : 1, ON/OFF, setting time and setting temperature blink on the display.

3. Select the desired day of the week

Press **Mon-Sun** (DAY) button.

The day changes from Mon → Tue → Wed → Thu → Fri → Sat → Sun → Mon, Tue, Wed, Thu, Fri, Sat, Sun [Full days] → Mon, Tue, Wed, Thu, Fri [weekday] → Sat, Sun [weekend] → Mon → Tue

Select [Full days] for daily reservation.

Select [weekday] for Monday to Friday reservation.

Select [weekend] for Saturday and Sunday reservation.

- After reservation has been set, it is easy to check and edit at the same time.

3

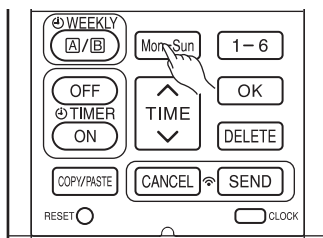

4. Press **1-6** button to select a program number.

The number changes from 1 → 2 → 3 → 4 → 5 → 6 → 1 → 2

- If program number has been set, follow above in order to make changes.

4

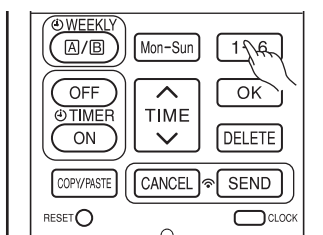

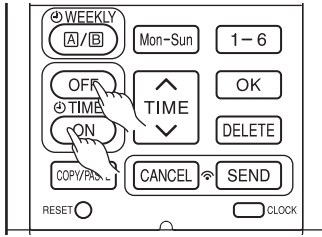

5

5. Press (ON-OFF TIMER) button to select ON TIMER or OFF TIMER reservation.

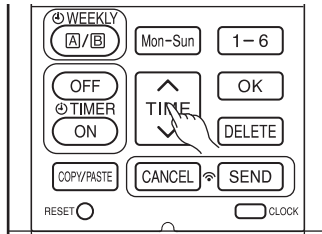

6

6. Press (TIME) button to set time reservation.

7. Press (TEMP ^ or v) button to set temperature reservation.

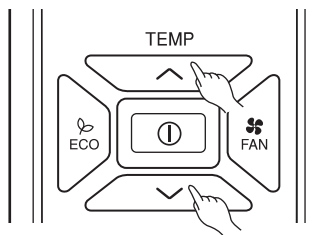

7

8. Press (OK) button. The reservations are set. Day, program number, ON reservation, setting temperature will light up. will be continuously blinks. If reservation is not complete, settings will not be stored in memory.

To continue with the reservation, press buttons. Follow step 3 to 8 for reservation.

9. After all the reservations have been set, press (SEND) button while directing the remote controller towards the indoor unit for about 3 seconds. Timer lamp on the indoor unit will blink rapidly.

After beep sound emitted from indoor unit, TIMER lamp will light up.

Please ensure that the TIMER lamp lights up.

This indicates that the reservation has been stored in the indoor unit and Timer function has been completed.

The reservation contents will appear on the remote controller display.

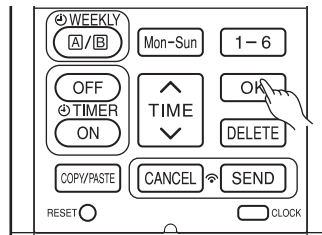

8

- If TIMER lamp on the indoor unit does not light up, press (SEND) button while directing the remote controller towards the indoor unit for about 3 seconds.

- **CAUTION !** Do not press (CANCEL) button during reservation setting because this will result in all reservation contents to be lost.

- The reservation contents will not stored in the indoor unit until (SEND) button has been pressed.

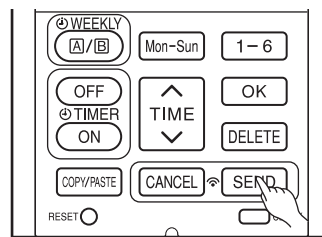

9

NOTE

- Up to 6 programs can be set per day. Setting ON TIMER or OFF TIMER for each program number can be at random. When pressing (SEND) button, the set ON TIMER or OFF TIMER for each program number will automatically arranged so that program number 1 shall have the earliest time and program number 6 shall have the latest time.

If the setting time is the same, Priority will be given to the latest reservation contents.

- **CAUTION !** If the remote controller is left idle and (SEND) button is not pressed within 3 minutes after reservations have been made , all current reservations will be lost.



WEEKLY TIMER OPERATION

Step 2: Select Mode A or Mode B and activate or deactivate WEEKLY TIMER.

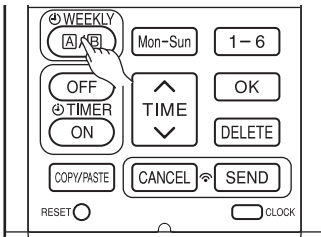

1

■ How to select Mode A or Mode B of WEEKLY TIMER setting.

1. Press (WEEKLY) button. **A** and blink on the display. (Normally Mode A will blink first).
2. Press (WEEKLY) button again. **B** and blink on the display.
3. Select Mode A or Mode B. Press (SEND) button while directing the remote controller towards the indoor unit for about 3 seconds. Timer lamp on the indoor unit will blink rapidly.

2

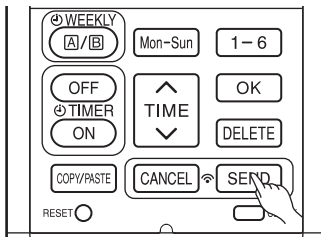

3

After beep sound emitted from indoor unit, TIMER lamp will light up.

Please ensure that the TIMER lamp lights up.

This indicates that Mode A or Mode B selection and active WEEKLY TIMER have been confirmed.

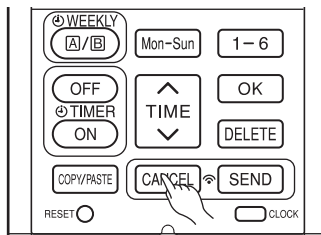

1

■ Setting non-active WEEKLY TIMER .

1. Direct the remote controller towards the indoor unit and press (CANCEL) button.
Beep sound will be emitted from indoor unit and TIMER lamp will be OFF. Reservation indication on remote display will also disappear. This indicates that non-active WEEKLY TIMER has been confirmed.
- To activate back the setting of WEEKLY TIMER , repeat the steps for "How to select Mode A or Mode B of WEEKLY TIMER setting".

NOTE

- When setting ONCE TIMER, operation of WEEKLY TIMER is interrupted. After ONCE TIMER operation is complete, WEEKLY TIMER operation will be activated.
- When ONCE TIMER is cancelled, operation of WEEKLY TIMER is also cancelled. Need to set WEEKLY TIMER operation for activation.
- After auto restart, WEEKLY TIMER operation is cancelled. Need to set WEEKLY TIMER operation for activation.



WEEKLY TIMER OPERATION

Step 3: Copy and cancel the reservation schedule.

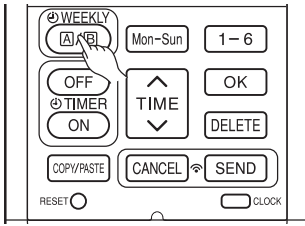

1

■ How to copy and paste.

Editing the reservation schedule is easy by copying data from one day to another day.

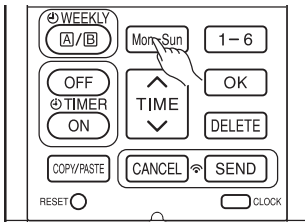

2

1. Press (WEEKLY) button to select Mode A or Mode B.

2. Press (WEEKLY) button for about 3 seconds to start editing the reservation schedule.

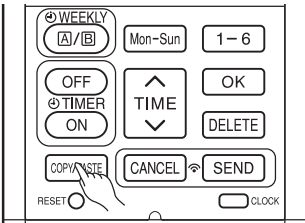

3

3. Press (DAY) button to select a day of the week to copy.

4. Press (COPY/PASTE) button. Then "PASTE" blinks on the display.

* Press (CANCEL) button to cancel the COPY mode. Normal setting mode is activated.

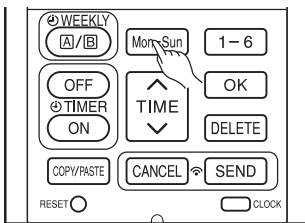

4

5. Press (DAY) button to select a day of the week to paste.

6. Press (COPY/PASTE) button one more time to paste. only blinks on the display.

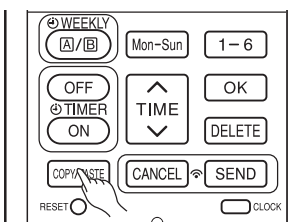

5

7. To continue copying to other days, press or or or



Then start from step 3.

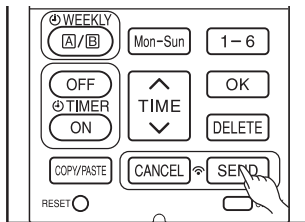

6

8. After copy and paste completed, press (SEND) button while directing the remote controller towards the indoor unit for about 3 seconds. Timer lamp on the indoor unit will blink rapidly.

After beep sound emitted from indoor unit, TIMER lamp will light up.

Please ensure that the TIMER lamp lights up.

If TIMER lamp does not light up, Press (SEND) button again.

8

● Reservation data will not change if (SEND) button is not pressed.

NOTE

- If there is no reservation data, copying data from one day to another day cannot be done.



WEEKLY TIMER OPERATION

Step 3: Copy and cancel the reservation schedule.

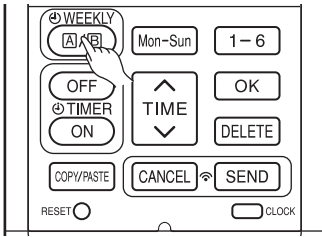

1

■ How to delete WEEKLY TIMER data.

[Delete one program number reservation]

2

1. Press (WEEKLY) button to select Mode A or Mode B.

2. Press (WEEKLY) button for 3 seconds to start editing the reservation schedule.

3. Press (DAY) button to select a day of the week to edit.

3

4. Press to select program number. Selected program number will blink.

5. Press (DELETE) button. Reservation of selected program number is deleted.

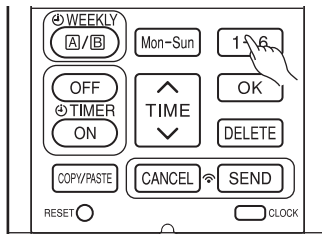
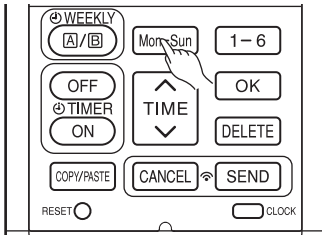

4

6. After deleting, press (SEND) button while directing the remote controller towards the indoor unit for about 3 seconds. Timer lamp on the indoor unit will blink rapidly.

After beep sound emitted from indoor unit, TIMER lamp will light up.

Please ensure that the TIMER lamp lights up.

● Reservation will not change if (SEND) button is not pressed.

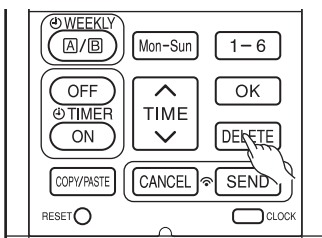

5

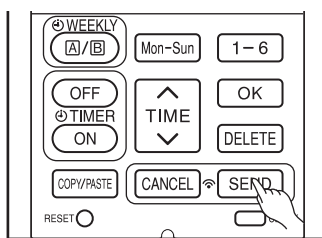

6



WEEKLY TIMER OPERATION

Step 3: Copy and cancel the reservation schedule.

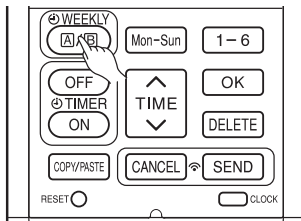

1

[Delete one day reservation]

1. Press **WEEKLY (A/B)** (WEEKLY) button to select Mode A or Mode B.

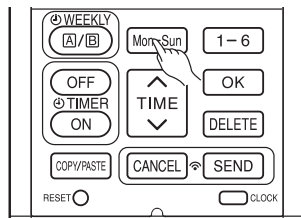

2

2. Press **WEEKLY (A/B)** (WEEKLY) button for 3 seconds to start editing the reservation schedule.

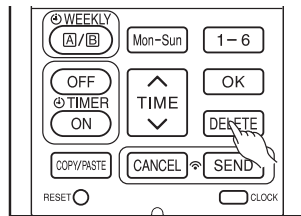

3

3. Press **Mon-Sun** (DAY) button to select a day of the week to edit.

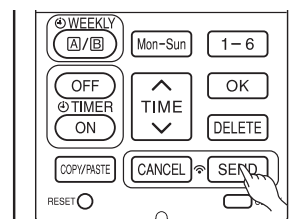

4

4. Press **DELETE** (DELETE) button for about 10 seconds. Reservations for all program numbers will be deleted.

- If press for a short time, reservation for one program number will be deleted.

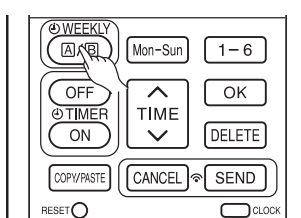

5

5. After deleting, press **SEND** (SEND) button while directing the remote controller towards the indoor unit for about 3 seconds. Timer lamp on the indoor unit will blink rapidly.

After beep sound emitted from indoor unit, TIMER lamp will light up.

Please ensure that the TIMER lamp lights up.

- Reservation will not change if **SEND** (SEND) button is not pressed.

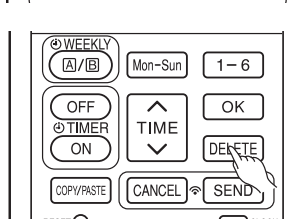

1

[Delete Mode A or Mode B]

1. Press **WEEKLY (A/B)** (WEEKLY) button to select Mode A or Mode B.

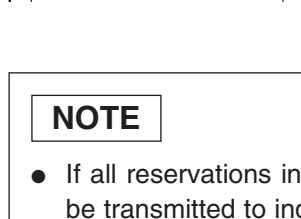

2

2. Direct the remote controller towards the indoor unit and press **DELETE** (DELETE) button for about 10 seconds while Mode A or Mode B display blinks.



After beep sound emitted from indoor unit, reservations for Mode A or Mode B will disappear.

NOTE

- If all reservations in the remote controller were deleted and pressed **SEND** (SEND) button, no signal will be transmitted to indoor unit. TIMER lamp will remain off and no changes will be done to the reservations stored in the indoor unit.



INFO FUNCTION

- By pressing  (INFO) button, temperature around remote controller and monthly power consumption will be displayed on the remote controller.
- After changing the batteries, direct the remote controller towards the indoor unit and press  (INFO) button. Current calendar and clock will be transmitted from indoor unit.
- In order to receive information from indoor unit, the distance between remote controller and receiver of indoor units is within 2 meters.

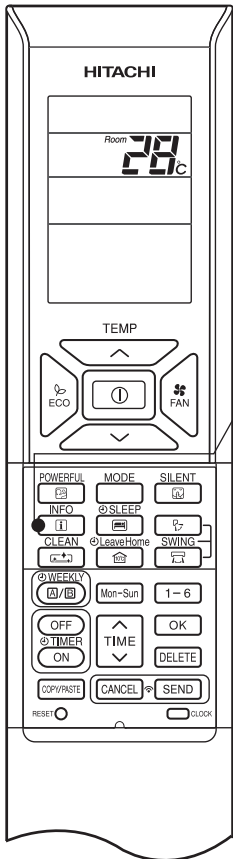

■ To check temperature around remote controller

1

Press  (INFO) button.

Temperature will be displayed for 10 seconds.

■ To check monthly power consumption

Direct the remote controller towards the receiver of indoor unit (within 2 meters in front of indoor unit) and press  (INFO) button. Wait for 2 seconds for signal transmission.

While temperature around remote controller is displayed, press  (INFO) button repeatedly. The display will show as below:

this month power consumption amount for heating → last month power consumption amount for heating → this month power consumption amount for cooling → last month power consumption amount for cooling → temperature around remote controller → this month power consumption amount for heating cyclically.

- If indication is not given, bring remote controller closer to the receiver of the indoor unit.
- Indicated value shall be regarded as a guide only.



■ Current calendar and clock can be retrieved from indoor unit

Direct the remote controller towards the receiver of indoor unit (within 2 meters in front of indoor unit) and press  (INFO) button. Wait for 2 seconds for signal transmission.

Once received the current calendar and clock, check whether they are correct or not by pressing  (CLOCK) button.

- If there is no power supply to indoor unit or calendar and clock have not been set, INFO function cannot be used for sending or receiving information.

NOTE

- In case failure occurs to the air conditioner, by pressing  (INFO) button, an error code will be displayed. Direct the remote controller towards the receiver of indoor unit (within 2 meters in front of indoor unit) and press  (INFO) button. Wait for 2 seconds for signal transmission. An error code will be displayed. Call service center and inform the error code.
- Information of "Monthly power consumption" is not available for 6 rooms multi system.
- Info Function to check monthly power consumption. During installation, in case of power failure or breaker ON / OFF, ensure to set the clock and calendar for each indoor unit (unit in standby mode or auto restart), for single or multi connection, by pressing  (START / STOP) button. Failure to do the above, monthly power consumption amount will not be displayed on the remote controller.

OPERATION MODE LOCK

The remote controller can be set to fix the HEATING mode (including FAN), COOLING mode (including FAN) and DEHUMIDIFYING mode (including FAN) operations.

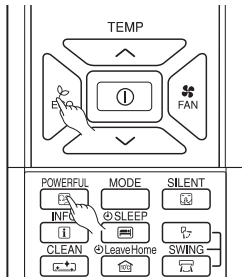

- Method to lock HEATING mode (including FAN) operation.

Press (ECO) and (POWERFUL) buttons simultaneously for about 5 seconds when the remote controller is OFF.

“”, “” and “” will be displayed for about 10 seconds. Later, “” and “” will remain.

This indicates that HEATING mode operation is locked.

When pressing (MODE) button, “” or “” will be displayed.

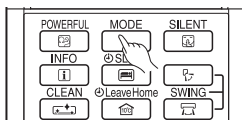

- Method to unlock HEATING mode (including FAN) operation.

Press (ECO) and (POWERFUL) buttons simultaneously for about 5 seconds when the remote controller is OFF.

All operation mode symbols will appear on the display for about 10 seconds. After that, operation mode symbol before cancellation will be displayed.

This indicates that HEATING mode operation is unlocked.

- Method to lock COOLING and DEHUMIDIFYING modes (including FAN) operations.

Press (ECO) and (SILENT) buttons simultaneously for about 5 seconds when the remote controller is OFF.

“”, “”, “” and “” will be displayed for about 10 seconds. Later, “” and “” will remain.

This indicates that COOLING and DEHUMIDIFYING mode operation is locked.

When pressing (MODE) button, “”, “” or “” will be displayed.

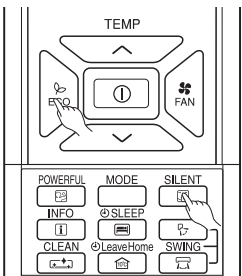

- Method to unlock COOLING and DEHUMIDIFYING modes (including FAN) operations.

Press (ECO) and (SILENT) buttons simultaneously for about 5 seconds when the remote controller is OFF.

All operation mode symbols will appear on the display for about 10 seconds. After that, operation mode symbol before cancellation will be displayed.

This indicates that COOLING and DEHUMIDIFYING modes operation is unlocked.

NOTE

- Operation Mode Lock function will not activate if TIMER reservations activate. TIMER reservations shall be deactivated first. Then, Operation Mode Lock function can be activated.
- HEATING, COOLING and DEHUMIDIFYING mode (including FAN) operations can be unlocked by pressing the (RESET) button. However, by pressing the (RESET) button, all the information stored in the remote controller will disappear. You may need to set the necessary information again.
- For multi connections, unit and mode which is set to lock HEATING and switched on first shall have higher priority. Other units which are chosen to operate at different modes shall be in STANDBY until either the first unit operation is switched off or the mode is selected to be same as the first unit.

CONSTRUCTION AND DIMENSIONAL DIAGRAM

MODEL RAK-70PPD

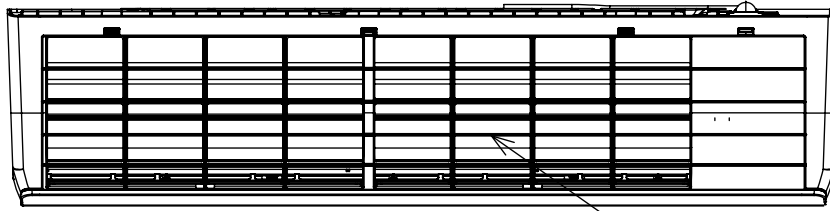

Top air suction grill

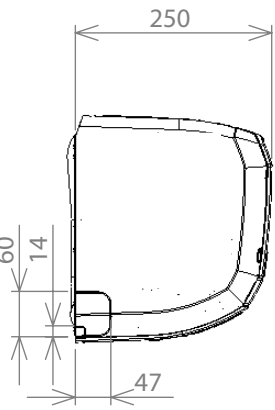

Discharge grille

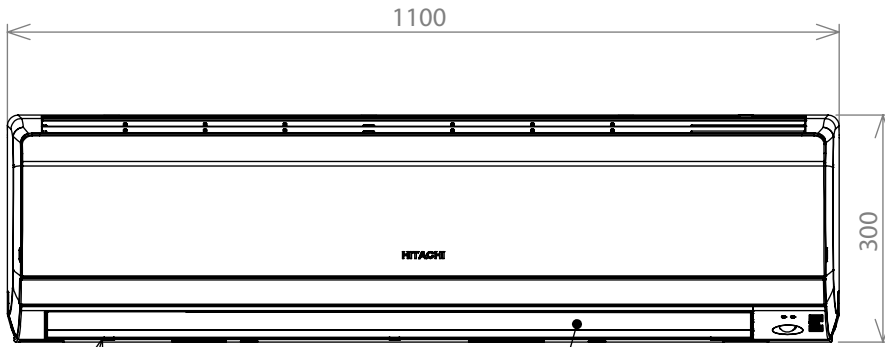

Horizontal deflector

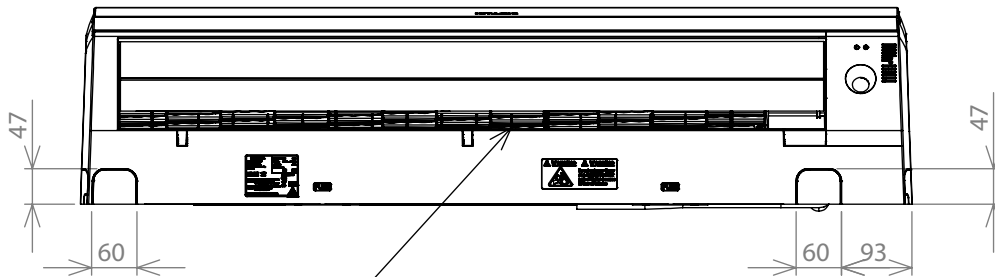
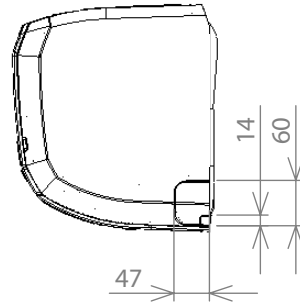

Vertical deflector

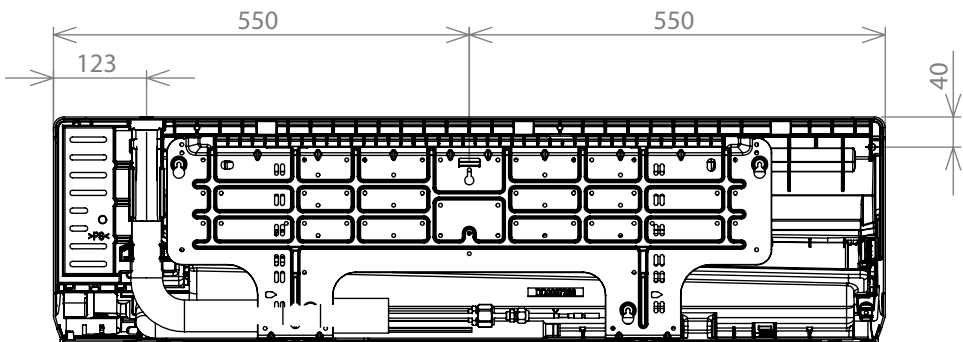

CONSTRUCTION AND DIMENSIONAL DIAGRAM

MODEL RAC-70NPD

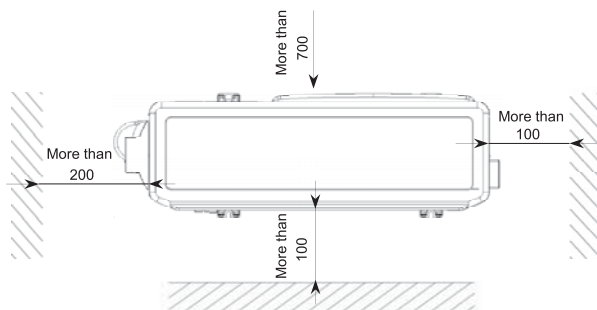
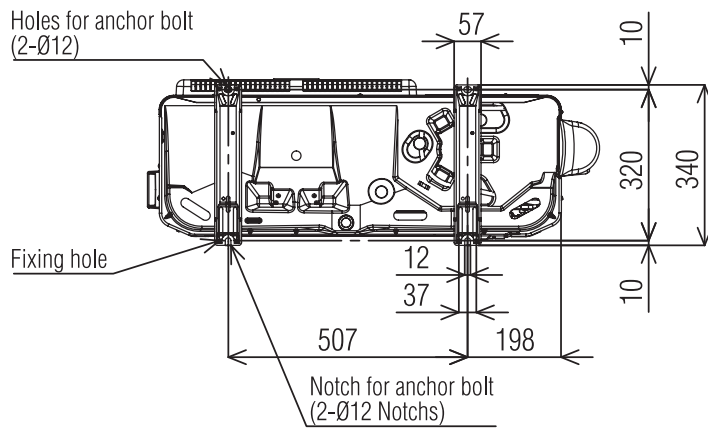
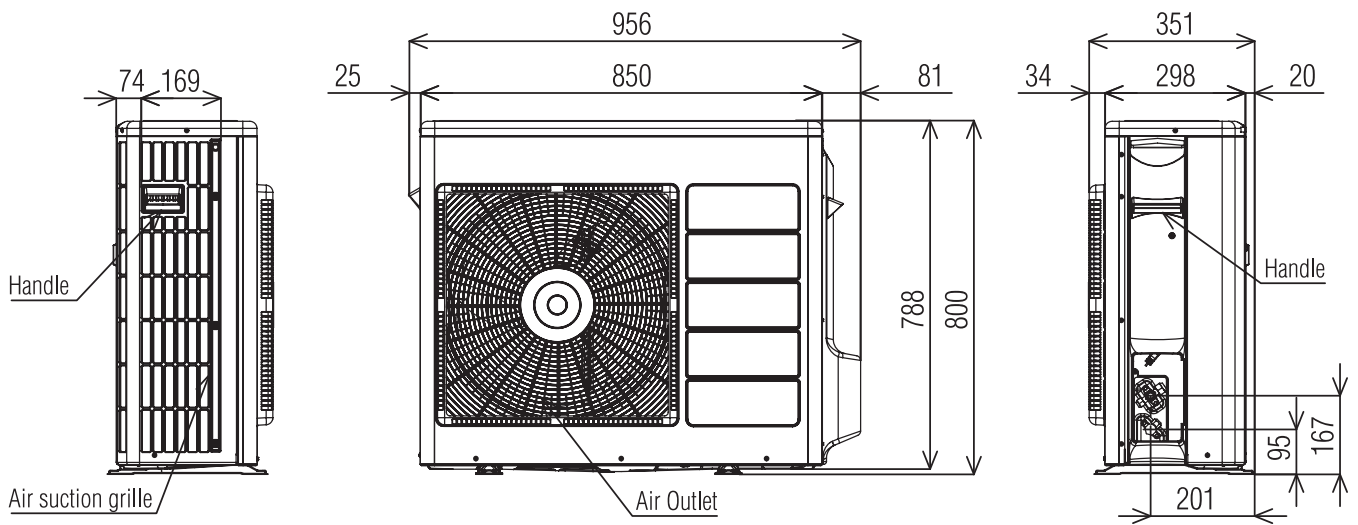

Service space

MAIN PARTS COMPONENT

THERMOSTAT (Room Temperature Thermistor)

Thermostat Specifications

MODEL			MODEL RAK-70PPD	
THERMOSTAT MODEL			IC	
OPERATION MODE			COOL	HEAT
TEMPERATURE °C (°F)	INDICATION 16	ON	15.6 (60.1)	20.0 (68.0)
		OFF	15.3 (59.5)	20.7 (69.3)
	INDICATION 24	ON	23.6 (74.5)	28.0 (82.4)
		OFF	23.3 (73.9)	28.7 (83.7)
	INDICATION 32	ON	31.6 (88.9)	36.0 (96.8)
		OFF	31.3 (88.3)	36.7 (98.1)

INDOOR FAN MOTOR

Fan Motor Specifications

MODEL	MODEL RAK-70PPD
POWER SOURCE	DC: 280V
OUTPUT	38W
CONNECTION	<p>DC 280V ○ RED 0V ○ BLK DC 15V ○ WHT 0 ~ 6V ○ YEL FG ○ BLU</p> <p>(Control circuit built in)</p>

OUTDOOR FAN MOTOR

Fan Motor Specifications

ITEM	MODEL	MODEL RAC-70NPD
POWER SOURCE		DC: 120 ~ 380V
OUTPUT (W) MAX		47
COIL		<p>RED (U) BLACK (W) WHITE (V)</p>
RESISTANCE VALUE (Ω)	20°C (60°F)	2M
		38.2 ± 3.9

BLU : BLUE
 GRY : GRAY
 BLK : BLACK

YEL : YELLOW
 ORN : ORANGE
 PNK : PINK

BRN : BROWN
 GRN : GREEN
 VIO : VIOLET

WHT : WHITE
 RED : RED

COMPRESSOR MOTOR

Compressor Motor Specifications

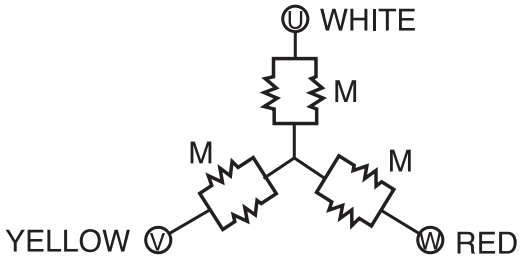
MODEL		MODEL RAC-70NPD
COMPRESSOR MODEL		JX151XG1
PHASE		SINGLE
RATED VOLTAGE		AC 220 ~ 240 V
RATED FREQUENCY		50 Hz
POLE NUMBER		4
CONNECTION		
RESISTANCE VALUE (Ω)	20°C (68°F)	2M = 1.2984
	75°C (167°F)	2M = 1.7671

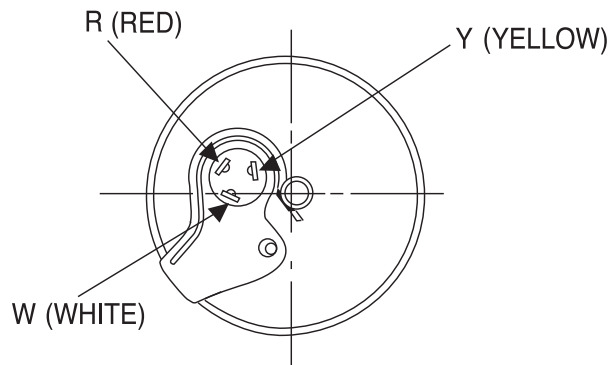

CAUTION

When the Air Conditioner has been operated for a long time with the strainer clogged or crushed or with too little refrigerant, check the color of the refrigerant oil inside the compressor. If the color has been changed conspicuously, replace the compressor.

WIRING DIAGRAM

MODEL RAK-70PPD/RAC-70NPD

- | | | | |
|-------------|--------------|--------------|-------------|
| BLU : BLUE | YEL : YELLOW | BRN : BROWN | WHT : WHITE |
| GRY : GRAY | ORN : ORANGE | GRN : GREEN | RED : RED |
| BLK : BLACK | PNK : PINK | VIO : VIOLET | IVO : IVORY |

INDOOR UNIT

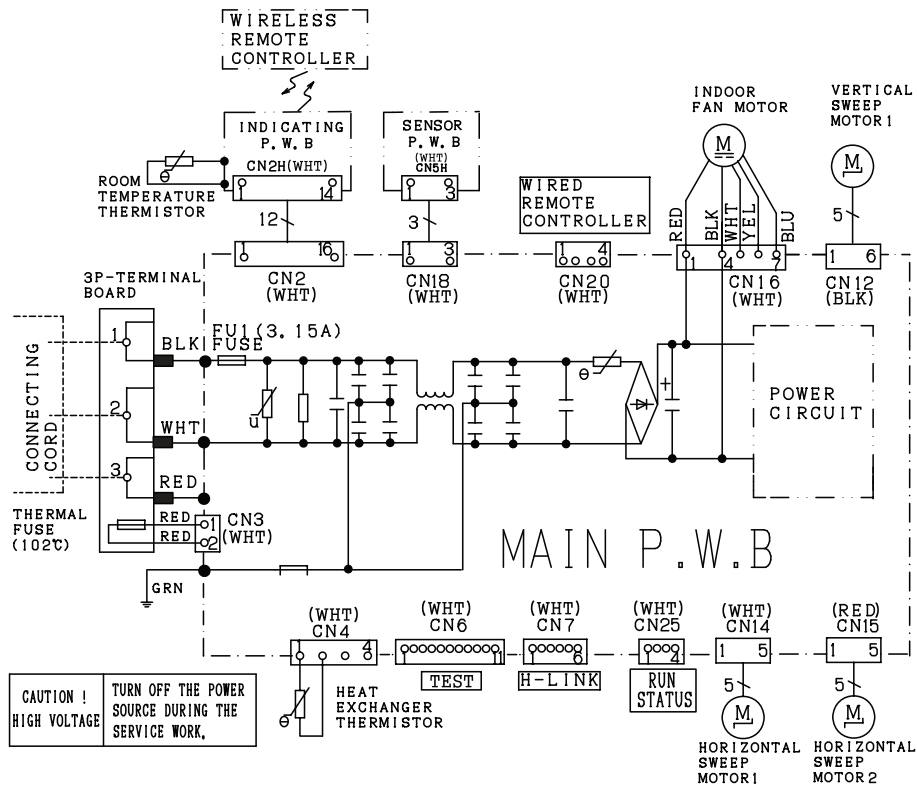

OUTDOOR UNIT

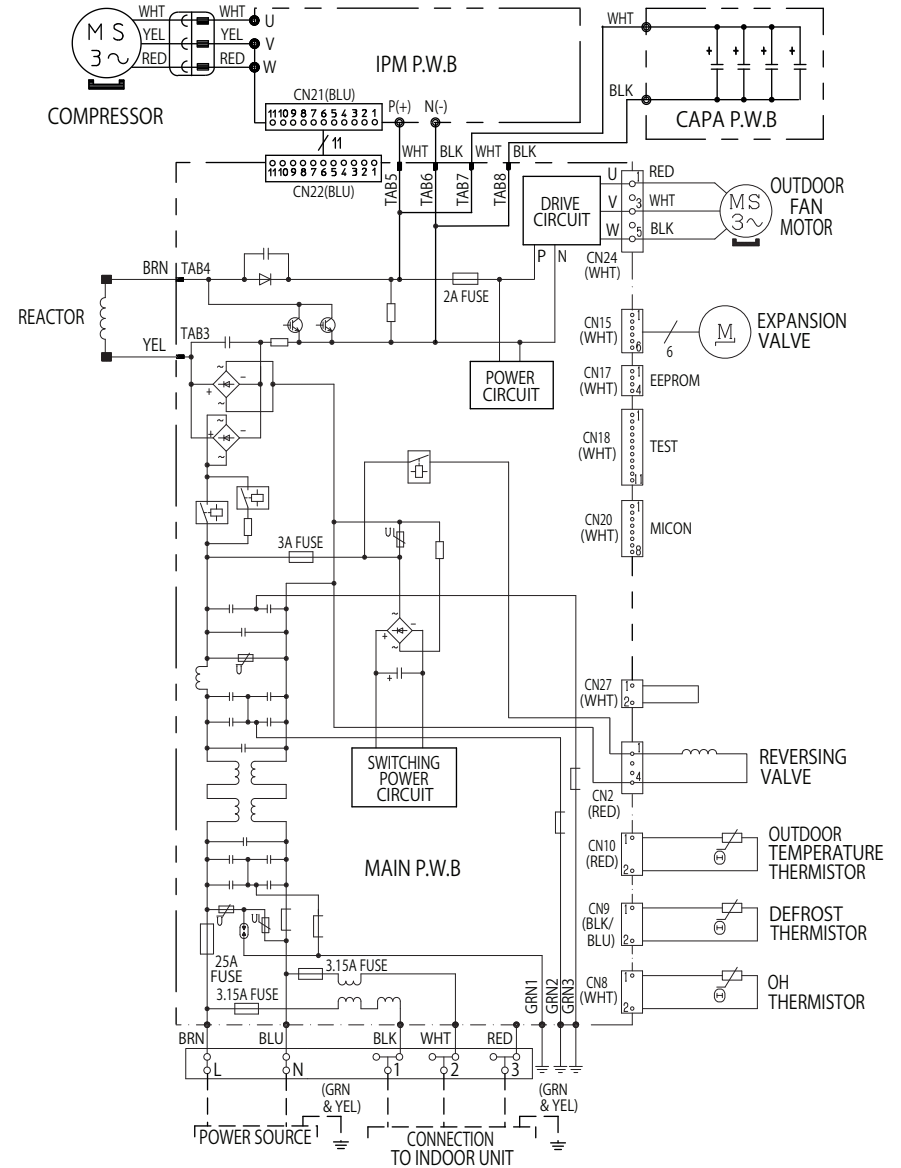

CIRCUIT DIAGRAM
 MODEL : RAC-70NPD
 P.W.B. : HIC

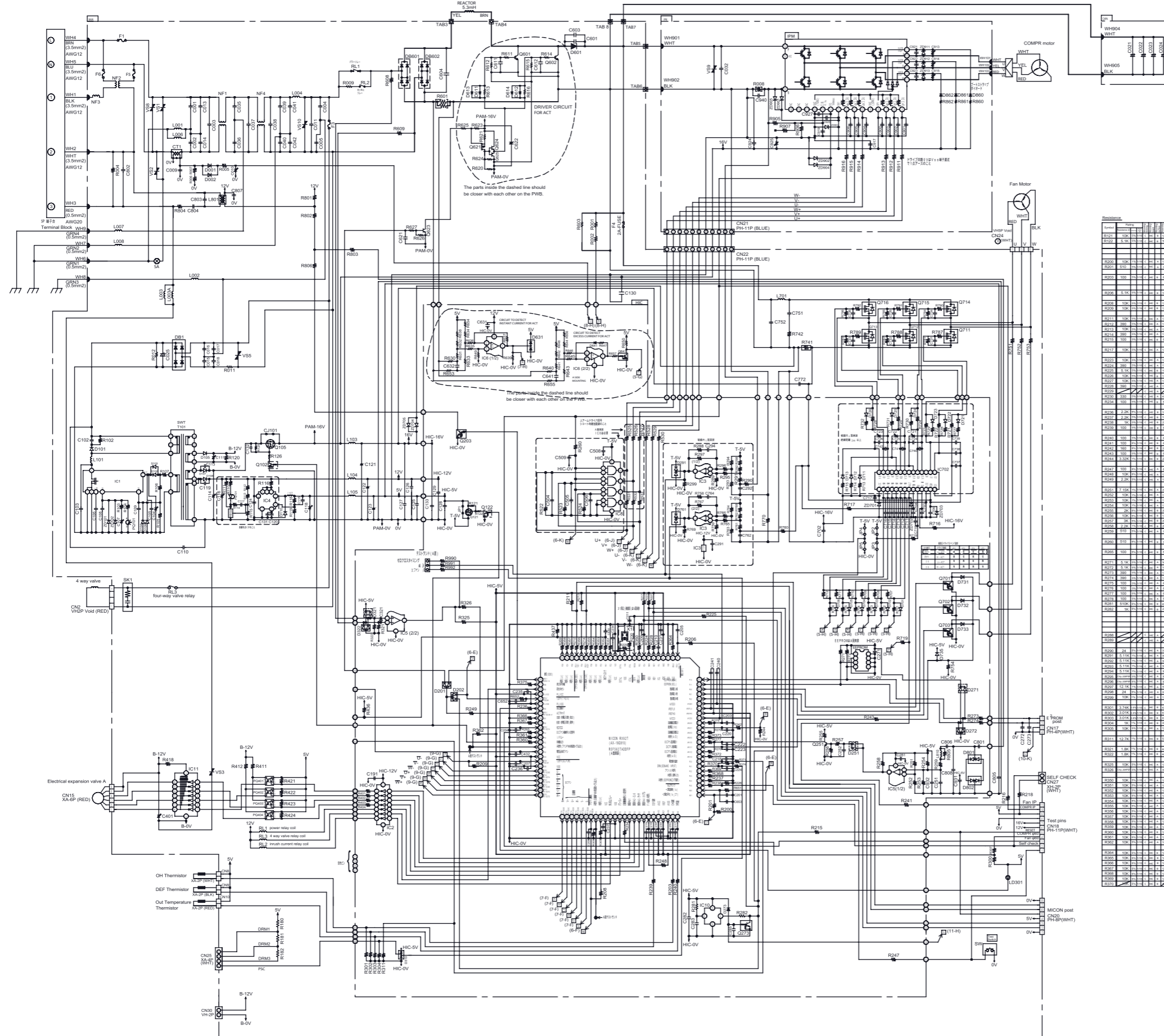

Mounting Forming
 A: AXIAL INSERTION
 R: RADIAL INSERTION
 P: RADIAL INSERTION (2.5mm pitch)
 H: HAND INSERTION
 C: CHIP

Mounting Board
 H: HIC PCB (HIC-80A02)

Resistor

Part No.	Value	Spec.	Notes
R11	10K	0.1%	
R12	10K	0.1%	
R13	10K	0.1%	
R14	10K	0.1%	
R15	10K	0.1%	
R16	10K	0.1%	
R17	10K	0.1%	
R18	10K	0.1%	
R19	10K	0.1%	
R20	10K	0.1%	

Resistor

Part No.	Value	Spec.	Notes
R21	10K	0.1%	
R22	10K	0.1%	
R23	10K	0.1%	
R24	10K	0.1%	
R25	10K	0.1%	
R26	10K	0.1%	
R27	10K	0.1%	
R28	10K	0.1%	
R29	10K	0.1%	
R30	10K	0.1%	

Capacitor

Part No.	Value	Spec.	Notes
C1	100nF	5%	
C2	100nF	5%	
C3	100nF	5%	
C4	100nF	5%	
C5	100nF	5%	
C6	100nF	5%	
C7	100nF	5%	
C8	100nF	5%	
C9	100nF	5%	
C10	100nF	5%	

Diode

Part No.	Type	Notes
D1	1N4148	
D2	1N4148	
D3	1N4148	
D4	1N4148	
D5	1N4148	
D6	1N4148	
D7	1N4148	
D8	1N4148	
D9	1N4148	
D10	1N4148	

Inductor

Part No.	Type	Notes
L1	100uH	
L2	100uH	
L3	100uH	
L4	100uH	
L5	100uH	
L6	100uH	
L7	100uH	
L8	100uH	
L9	100uH	
L10	100uH	

PRINTED BOARD LOCATION DIAGRAM

MAIN P.W.B
Marking on P.W.B

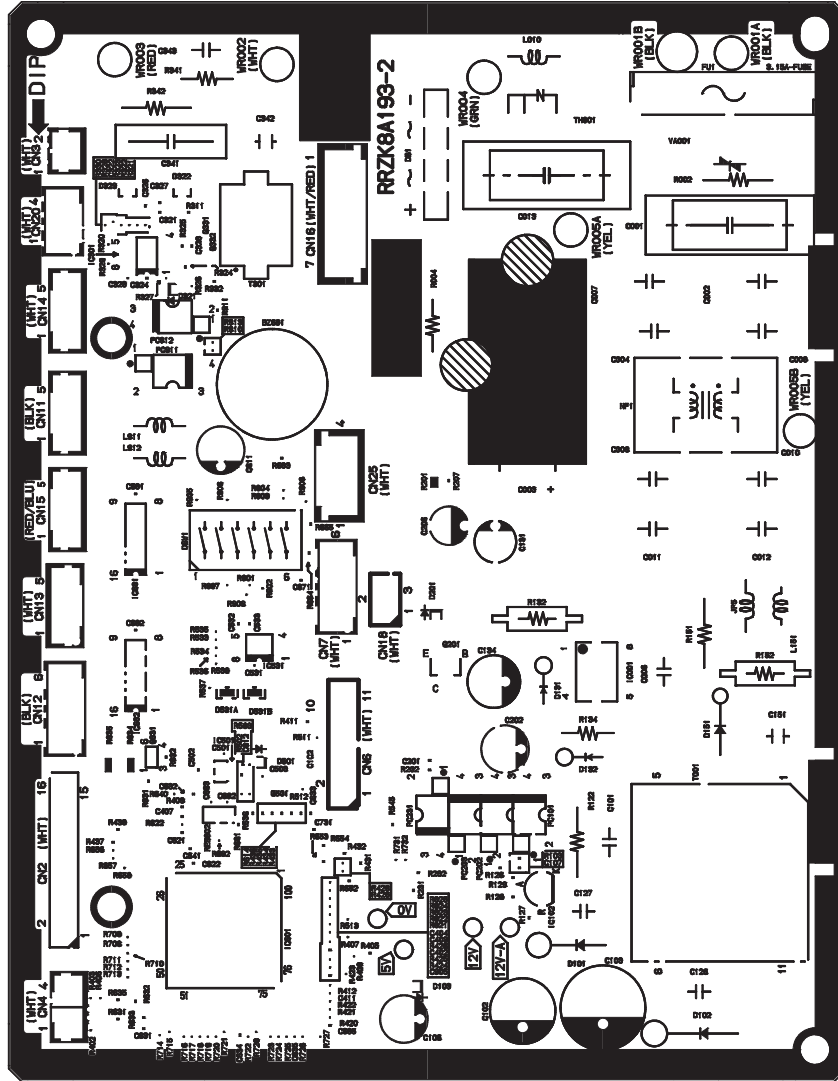

RECEIVING P.W.B
Marking on P.W.B

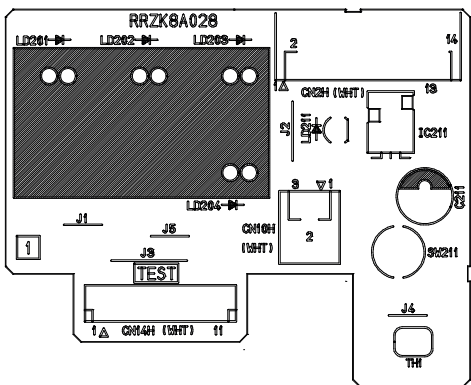

SENSOR P.W.B
Marking on P.W.B

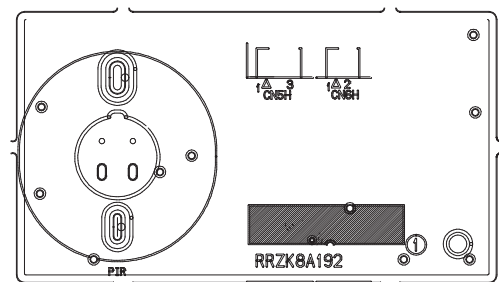

RAC-70NPD

BLOCK DIAGRAM

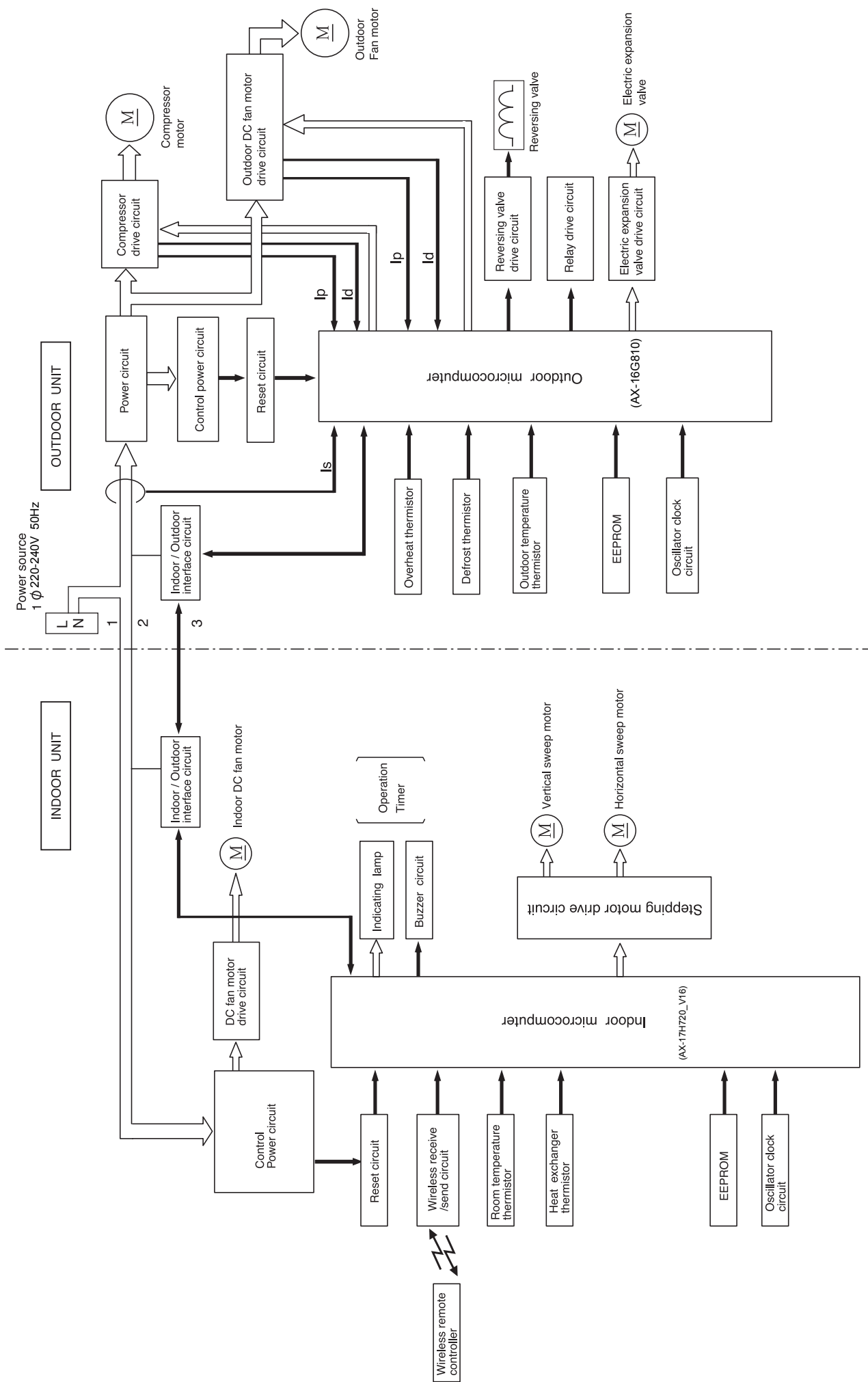

BASIC MODE

MODEL RAK-70PPD

Operation mode		Cooling	Dehumidifying	Heating
Basic operation of start/stop button				
Timer functions	Off-timer			
	On-timer			
Fan speed mode (indoor fan)	Auto	<p>Changes from "Hi" to "Med" or "Lo" depending on room temperature.</p> <ol style="list-style-type: none"> Runs at "Hi" until room temperature reaches to "setting temperature-SFTDSC" after operation is started. Runs at "ultra-Lo" when thermo is off. 		<p>Set to "ultra-Lo", "Silent", "Lo", "Med", "Hi", "ultra-Hi" or "stop" depending on the room temperature, time and heat exchanger temperature. Set to "stop" if the heat exchanger temperature is "DNZKOF" during Thermo OFF.(When reach at "DNZKON", fan speed set to "ultra-Lo" again.)</p> <p>In modes other than left</p> <p>When the compressor is running at maximum speed during hot-dash or when recovered from defrosting.</p> <p>90" Fan speed UP/DOWN delay time 90" Fan speed UP/DOWN delay time</p>
	Hi	Set to "ultra-Hi" when the compressor runs at cold dash mode speed, and to "Hi" in other modes. Runs at "ultra-Lo" when thermo is off.		Set to "ultra-Lo", "Silent", "Lo", "Med", "Hi", "ultra-Hi" or "stop" depending on the room temperature, time and heat exchanger temperature. Set to "stop" if the heat exchanger temperature is "DNZKOF" during Thermo OFF.(When reach at "DNZKON", fan speed set to "ultra-Lo" again.) Set to "ultra-Hi" when the compressor is running at maximum speed during hot dash or when recovered from defrosting.
	Med	Operates at "Med" regardless of the room temperature. Runs at "ultra-Lo" when thermo is off.		Set to "ultra-Lo", "Silent", "Lo", "Med", "Hi", "ultra-Hi" or "stop" depending on the room temperature, time and heat exchanger temperature. Set to "stop" if the heat exchanger temperature is "DNZKOF" during Thermo OFF.(When reach at "DNZKON", fan speed set to "ultra-Lo" again.)
	Lo	Operates at "Lo" regardless of the room temperature. Runs at "ultra-Lo" when thermo is off.	Set to "Lo" in modes other than when the compressor stops.	Set to "ultra-Lo", "Silent", "Lo", "Med", "Hi", "ultra-Hi" or "stop" depending on the room temperature, time and heat exchanger temperature. Set to "stop" if the heat exchanger temperature is "DNZKOF" during Thermo OFF.(When reach at "DNZKON", fan speed set to "ultra-Lo" again.) The fan speed is controlled by the heat exchanger temperature; the overload control is executed as in the following diagram:
	Silent	Operates at "Silent" regardless of the room temperature. Runs at "ultra-Lo" when thermo is off.	Set to "Silent" in modes other than when the compressor stops.	<p>"Med", "Lo", "Silent" × 108% "Med", "Lo", "Silent"</p>
Basic operation of temperature controller		See page 51.	See page 55.	See page 59.

Basic Cooling Operation

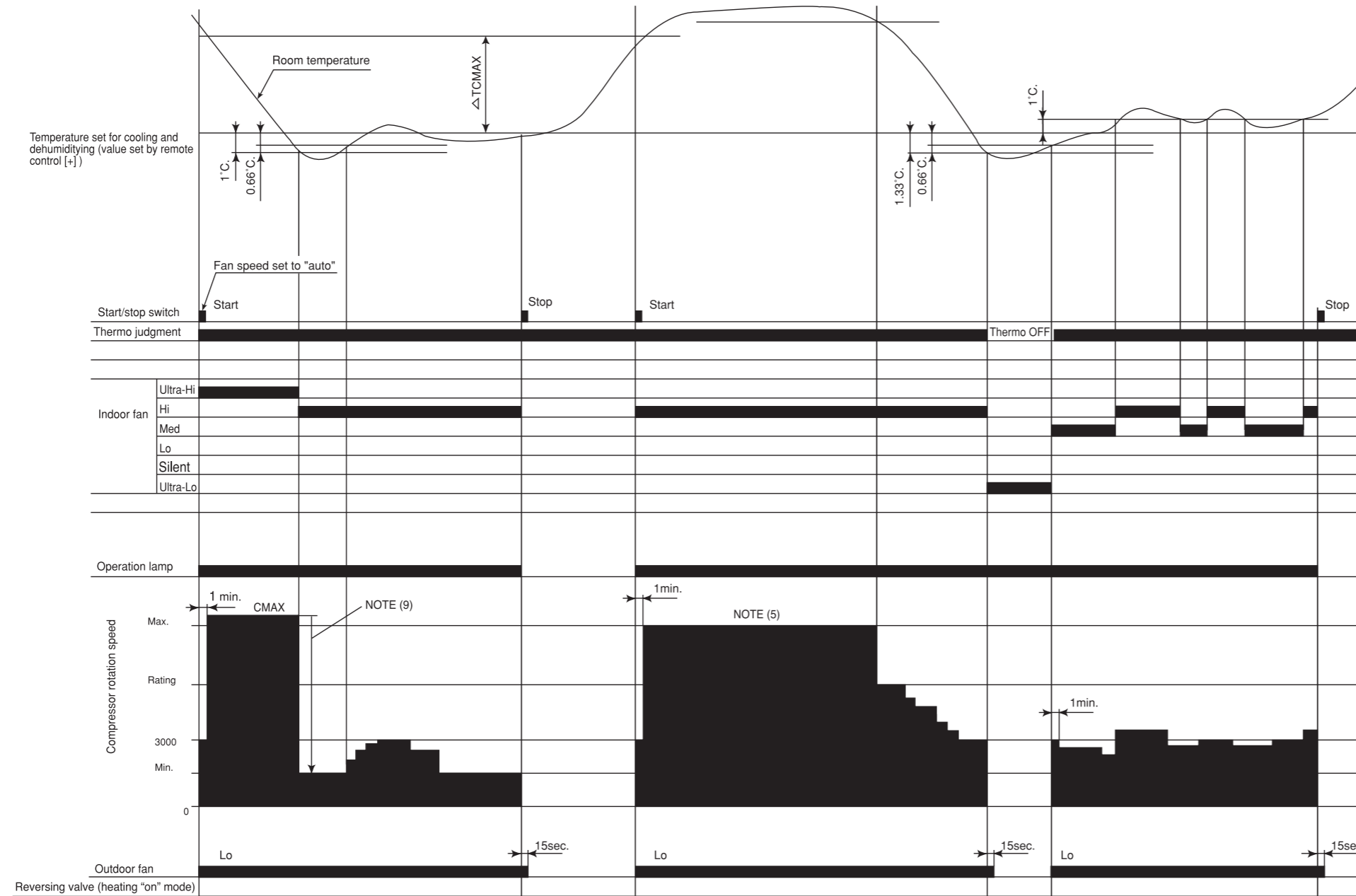

Notes:

- (1) Condition for entering into Cool Dashed mode. When fan set to "Hi" or "Auto" and when the compressor speed (P section) due to temperature difference between setting temperature (including the correction shift only) and room temperature is CMAX or higher.
- (2) Cool Dashed will release when i) a maximum 25 minutes is lapsed and ii) room temperature is lower than set temperature -3°C (thermo off) and iii) when room temperature has achieved setting temperature -1°C then maximum Cool Dashed time will be revised to 20 minutes. And iv) indoor fan is set to Lo and Med fan mode and v) change operation mode.
- (3) During Cool Dashed operation, thermo off temperature is set temperature (with shift value) -3°C . After thermo off, operation continue in Fuzzy control mode.
- (4) Compressor minimum "ON" time and "OFF" time is 3 minutes.
- (5) During normal cooling mode, compressor maximum rpm CMAX will maintain for 60 minutes if indoor temperature is lower than CLMXTP. No time constrain if indoor temperature is higher than CLMXTP.
- (6) When fan is set to "Hi", compressor rpm will be limited to CSTD.
- (7) When fan is set to "Med", compressor rpm will be limited to CJKMAX.
- (8) When fan is set to "Lo", compressor rpm will be limited to CBEMAX.
- (9) During Cool Dashed, when room temperature reaches set temperature -1°C compressor rpm is actual rpm x DWNRATEC.

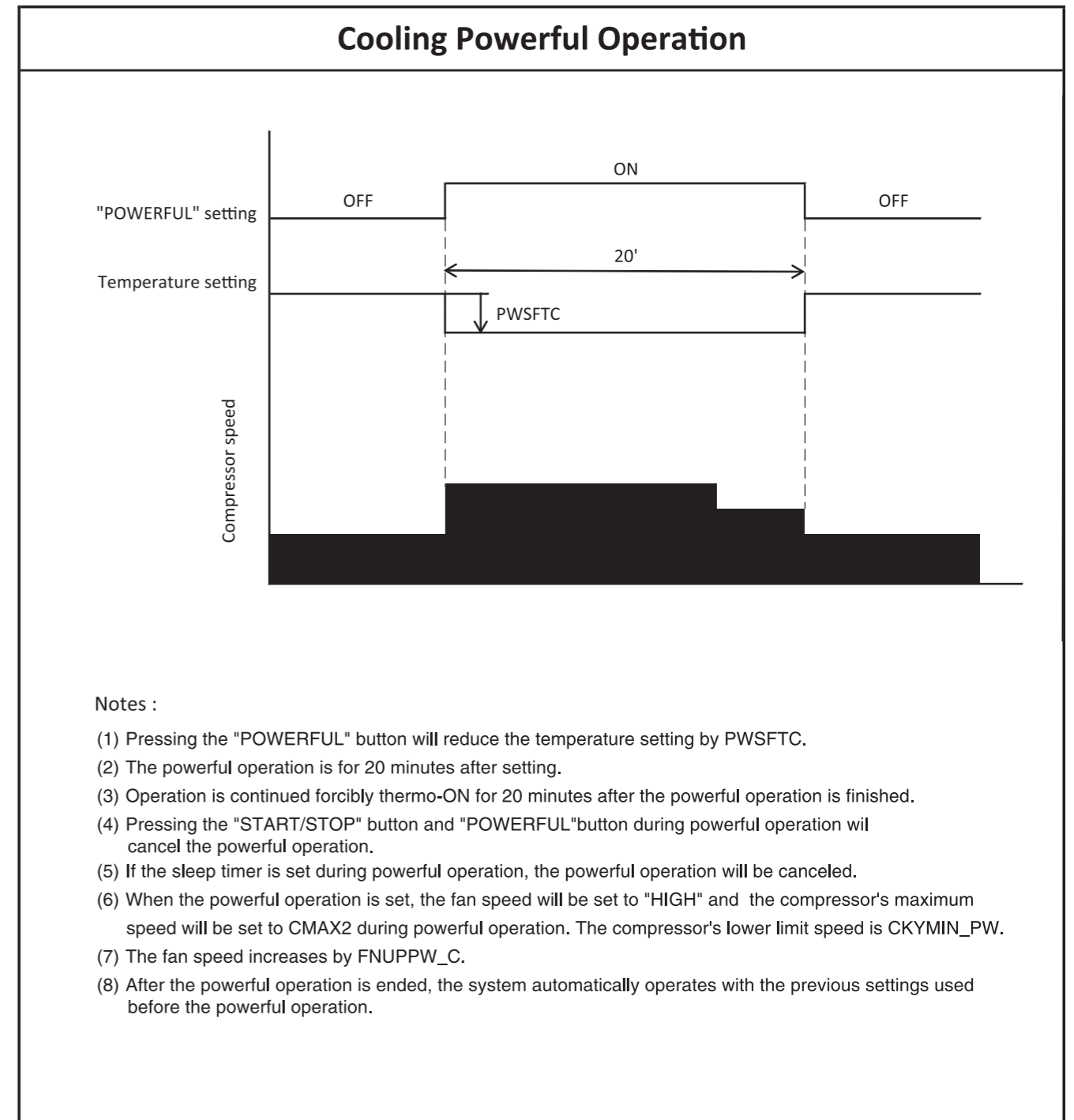
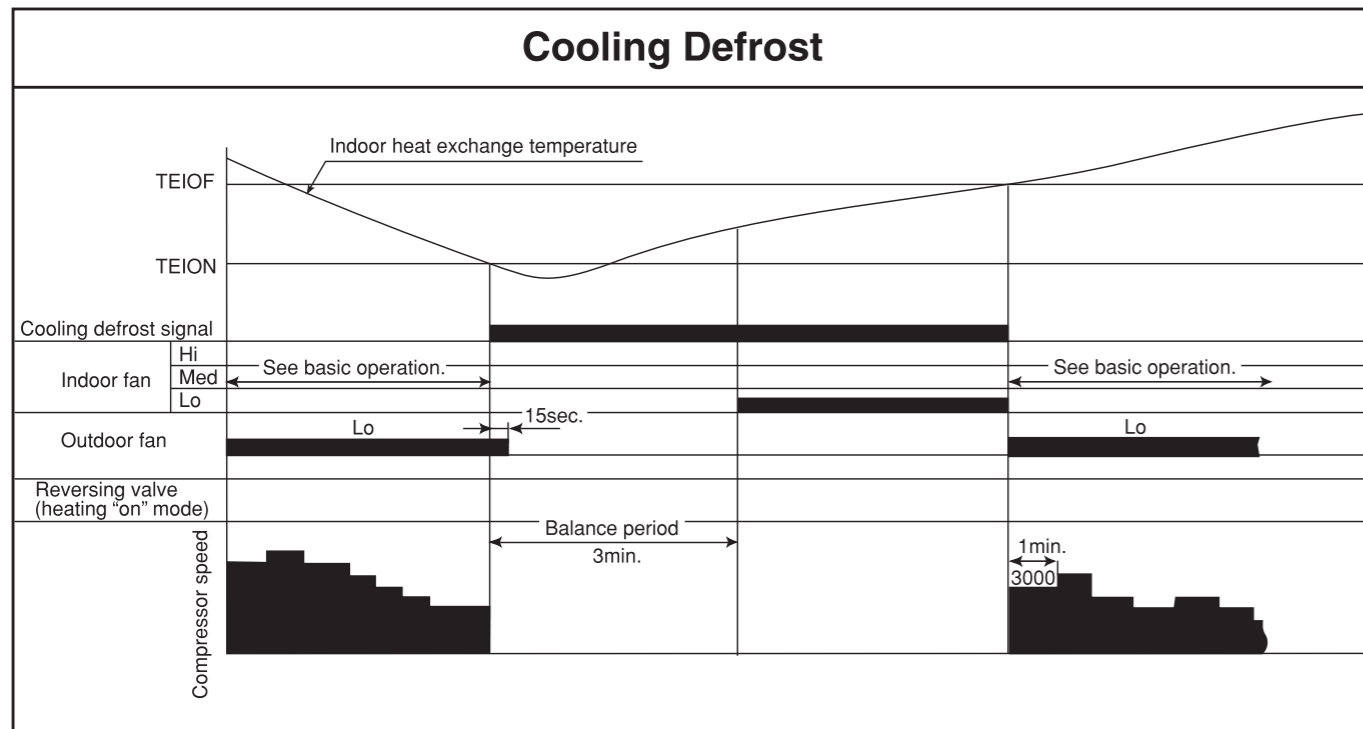

Notes :

- (1) Pressing the "POWERFUL" button will reduce the temperature setting by PWSFTC.
- (2) The powerful operation is for 20 minutes after setting.
- (3) Operation is continued forcibly thermo-ON for 20 minutes after the powerful operation is finished.
- (4) Pressing the "START/STOP" button and "POWERFUL" button during powerful operation will cancel the powerful operation.
- (5) If the sleep timer is set during powerful operation, the powerful operation will be canceled.
- (6) When the powerful operation is set, the fan speed will be set to "HIGH" and the compressor's maximum speed will be set to CMAX2 during powerful operation. The compressor's lower limit speed is CKYMIN_PW.
- (7) The fan speed increases by FNUPPW_C.
- (8) After the powerful operation is ended, the system automatically operates with the previous settings used before the powerful operation.

Dehumidifying

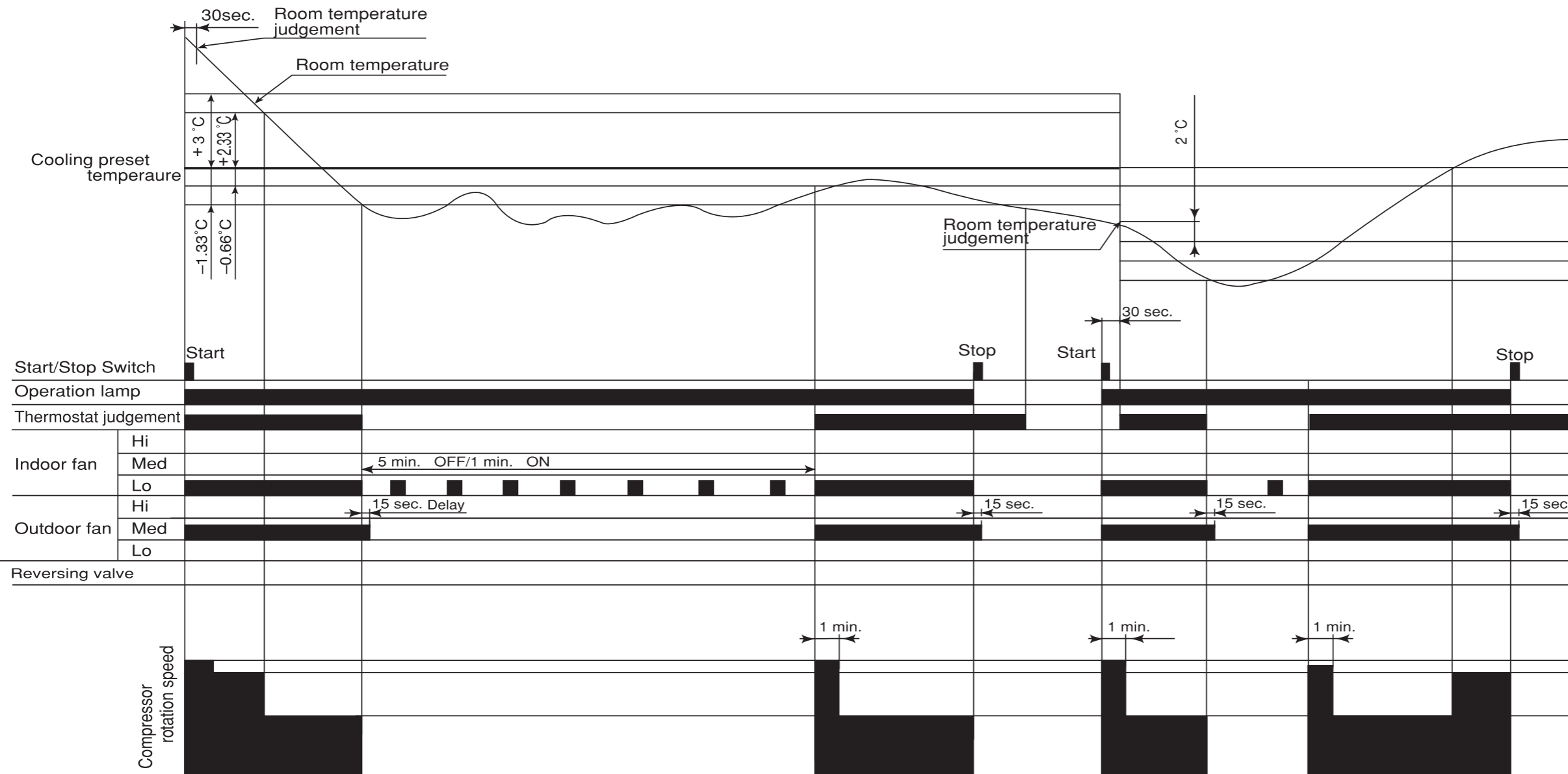

Notes:

- (1) If the room temperature is (cooling preset temperature) - (1.33°C) or less after 30 seconds from starting the operation, the operation is done assuming as the preset temperature = (room temperature at the time) - (2°C).
- (2) The indoor fan is operated in the "Lo" mode. During thermo OFF indoor fan will be OFF for 5 minutes and ON for 1 minute.
- (3) When the operation is started by the thermostat turning ON, the start of the indoor fan is delayed 32 seconds after the start of compressor operation.
- (4) The compressor is operated forcedly for 3 minutes after operation is started.
- (5) The minimum ON time and OFF time of the compressor are 3 minutes.

Dehumidifying Powerful Operation

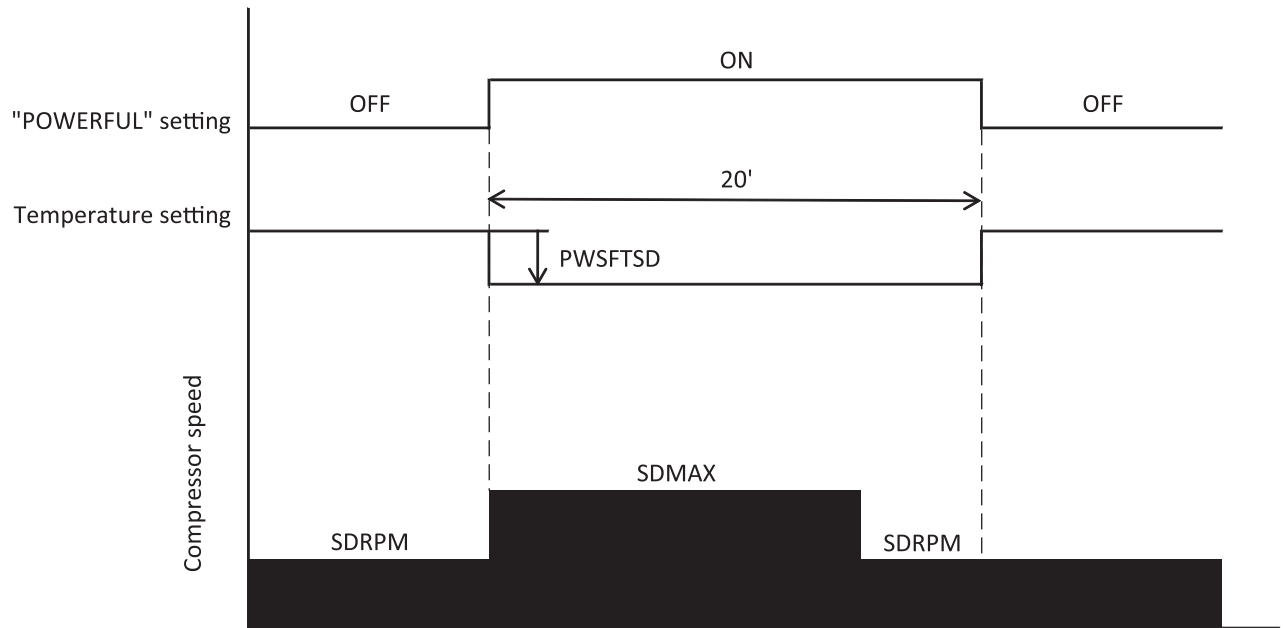

Notes :

- (1) Pressing the "POWERFUL" button will reduce the temperature setting by PWSFTSD.
- (2) The powerful operation is for 20 minutes after setting.
- (3) Operation is continued forcibly thermo-ON for 20 minutes after the powerful operation is finished.
- (4) Pressing the "START/STOP" button and "POWERFUL" button during powerful operation will cancel the powerful operation.
- (5) If the sleep timer is set during powerful operation, the powerful operation will be canceled.
- (6) If the differential (the room temperature - the temperature setting) is "the differential $\geq 3\text{ }^{\circ}\text{C}$ " after powerful setting, the compressor's maximum speed during powerful operation will be set to SDMAX. Then the differential reduce "the differential $\leq 2.33\text{ }^{\circ}\text{C}$ " during powerful operation, the compressor's speed will be set to SDRPM.
If the differential (the room temperature - the temperature setting) is "the differential $< 3\text{ }^{\circ}\text{C}$ " after powerful setting, the compressor's minimum speed during powerful operation will be set to SDRPM.
- (7) After the powerful operation is ended, the system automatically operates with the previous settings used before the powerful operation.

Basic Heating Operation

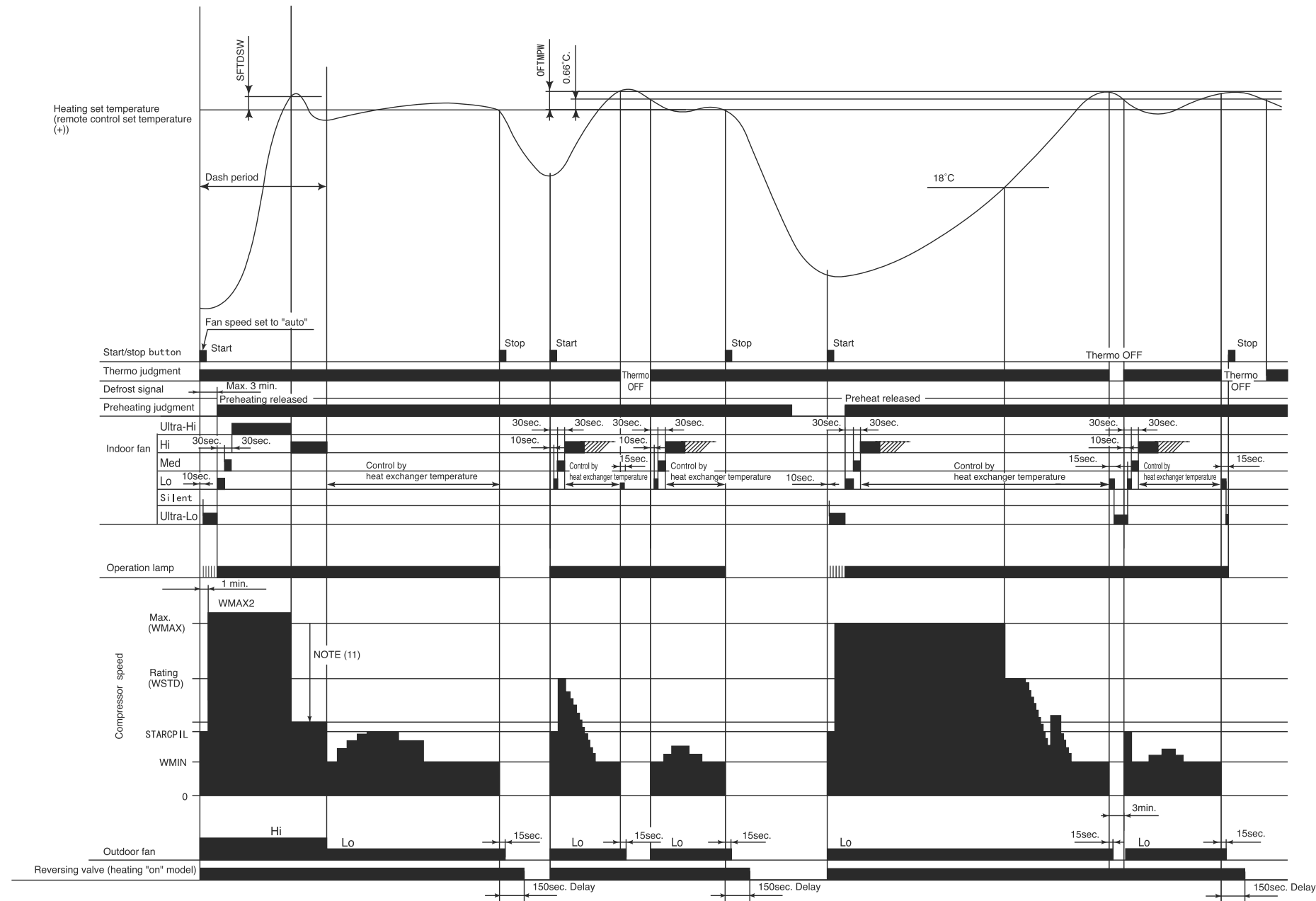

Notes:

- (1) Condition for entering into hot dashed mode. When fan set to "Hi" or "Auto" and i) room temperature is 18 or less, and ii) outdoor temperature is 10 or less, and iii) compressor speed (P section) due to temperature difference between setting temperature(including shift value only) and room temperature is WMAX or more.
- (2) The maximum compressor speed period during hot dash is finished when i) room temperature has reached the setting temperature + SFTDSW. ii) thermo off.
- (3) During hot dashed operation, thermo off temperature is setting temperature (with shift value) +3 . After thermo off, operation continue inn Fuzzy control mode.
- (4) Minimum "ON" time and minimum "OFF" time of compressor operation is 3 minutes.
- (5) During normal heating mode, compressor maximum rpm WMAX will maintain for 120 minutes. No time limit constrain if room temperature is 18 or less and outdoor temperature is 2 or less.
- (6) During preheating or defrosting or auto fresh defrosting mode, indoor unit operation lamp will blink at interval of 2 seconds "ON" and 1 second "OFF".
- (7) When heating mode starts, it will enter into preheating mode if indoor heat exchanger temperature is less than YNEOF + 0.33 .
- (8) When fan is set to "Med" or "Lo" or "Silent", compressor rpm will be limited to "WJKMAX" or "WBEMAX" or "WSZMAX".
- (9) During "Ultra-Lo" mode, heat exchanger temp 18 or less, indoor fan will stop. If hex temperature is 18 + 0.33 or more, fan will continue in "Ultra-Lo" mode. However, "Ultra-Lo" mode during preheating or preheating after defrosting does not stop if room temperature is 18 or less.
- (10) During hot dashed or outdoor temperature is -5 or less, compressor rpm is WMAX2.
- (11) During hot dashed, when room temperature reaches setting temperature + SFTDSW compressor rpm is actual rpm x DWNRATEW.

Reversing valve defrosting

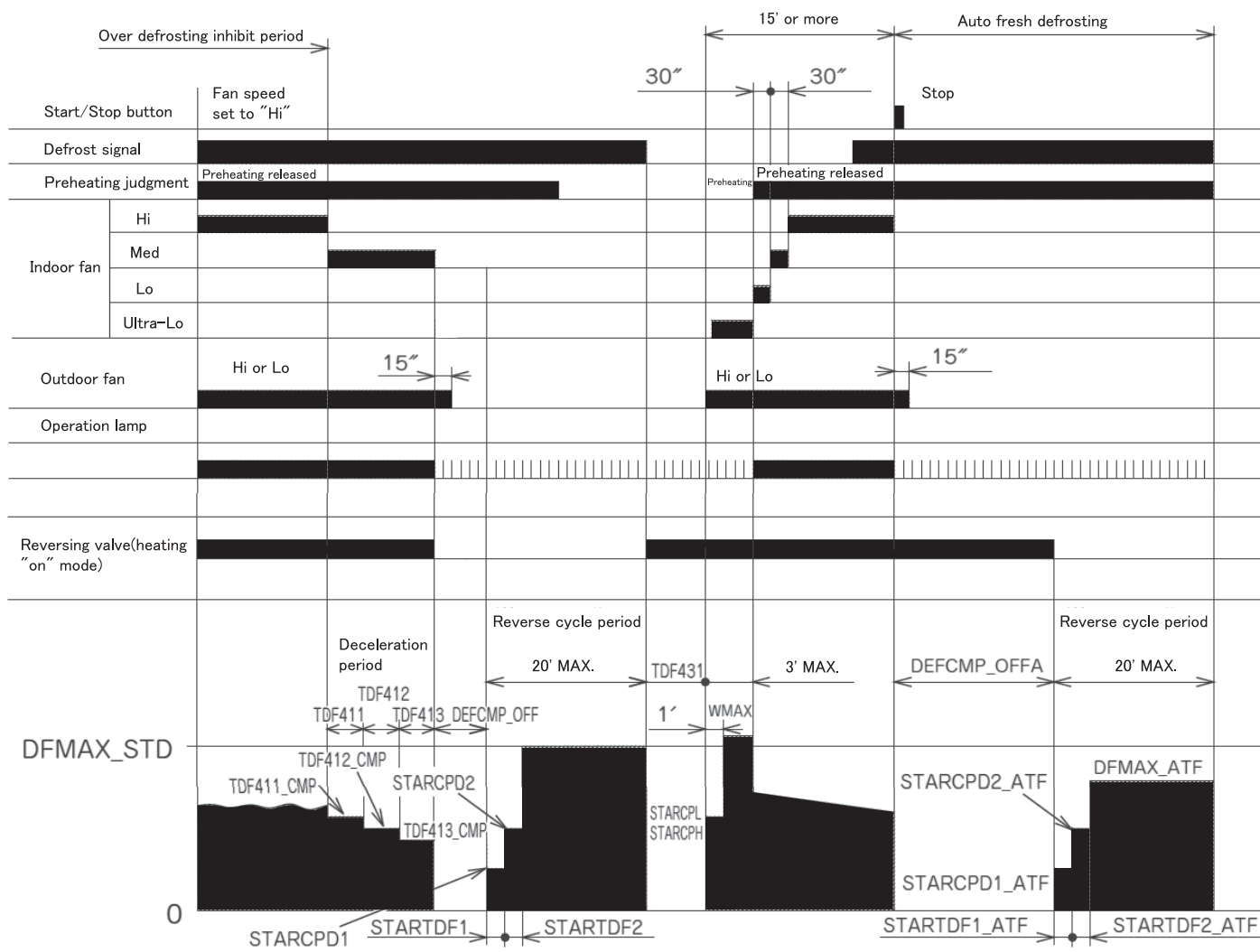

Notes:

- (1) The defrosting inhibit period is set as shown in the diagram below. When defrosting has finished once, the inhibit period is newly set, based on the outdoor temperature when the compressor was started. During this period, the defrost signal is not accepted.
- (2) If the difference between the room and outdoor temperature is large when defrosting is finished, the maximum compressor speed (WMAX) or (WMAX2) can be continued for 120 minutes maximum.
- (3) The defrosting period is 20 minutes maximum.
- (4) When operation is stopped during defrosting, it is switched to auto refresh defrosting.
- (5) Auto refresh defrosting cannot be engaged within 15 minutes after operation is started or defrosting is finished.

Setting Defrosting Inhibit Period

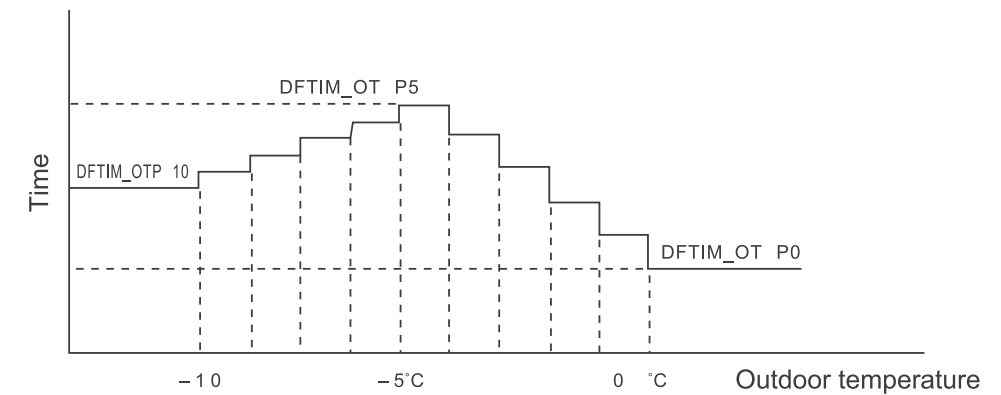

Notes:

- (1) The first inhibit time after operation start is set to DFTIM_FST.
- (2) From the second time onwards, the inhibit time is set according to the time required for defrosting.
Reverse cycle operation time \geq [DEFCOL] : DEFTIM_COL is set.
Reverse cycle operation time $<$ [DEFCOL] : The time corresponding to outdoor temperature is set.

Heating Powerful Operation

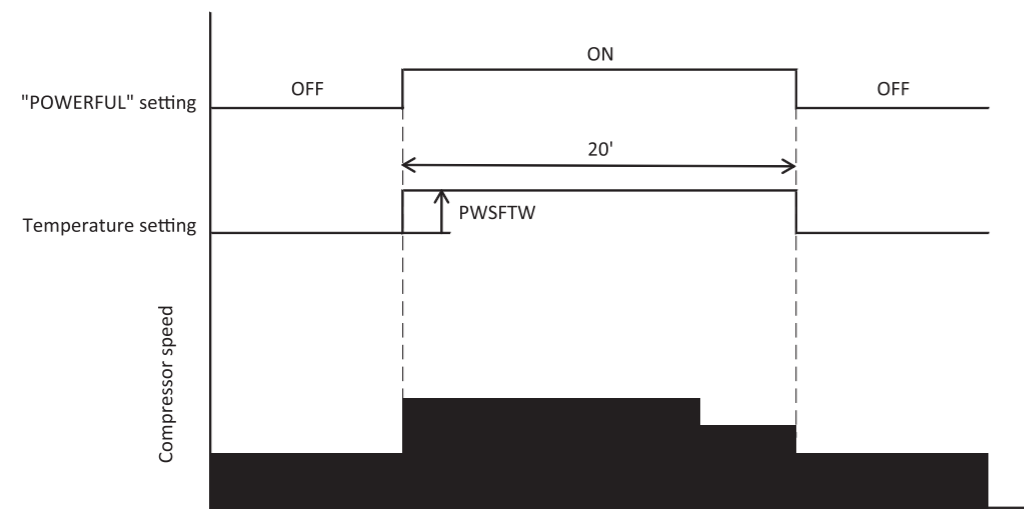

Notes :

- (1) Pressing the "POWERFUL" button will increase the temperature setting by PWSFTW.
- (2) The powerful operation is for 20 minutes after setting.
- (3) Operation is continued forcibly thermo-ON for 20 minutes after the powerful operation is finished.
- (4) Defrost is inhibited for 20 minutes after the start of the powerful operation.
- (5) Pressing the "START/STOP" button and "POWERFUL" button during powerful operation will cancel the powerful operation.
- (6) If the sleep timer is set during powerful operation, the powerful operation will be canceled.
- (7) When the powerful operation is set, the fan speed will be set to "HIGH" and the compressor's maximum speed will be set to WMAX2 during powerful operation. The compressor's lower limit speed is WKYMIN_PW.
- (8) After the powerful operation is ended, the system automatically operates with the previous settings used before the powerful operation.

Leave Home

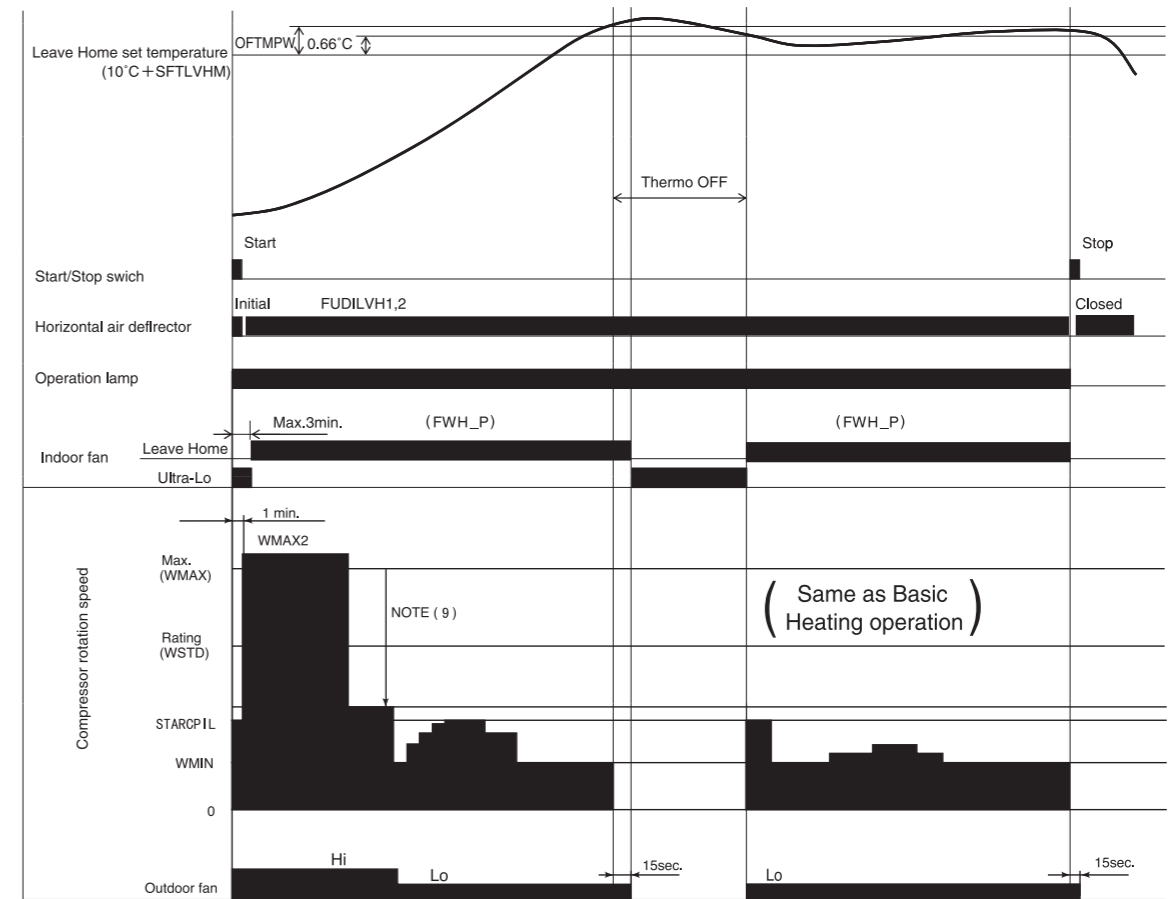

Notes:

Perform Leave Home operation according to the following control contents.

- (1) Operation mode : Heating
- (2) Setting temperature : 10°C
- (3) Shift value : + SFTLVHM
- (4) Indoor fan speed : FWH_P
- (5) Outdoor fan speed :
- (6) Compressor start control: } Same as Basic Heating operation
- (7) Compressor speed : }
- (8) Operation lamp : ON

ECO Operation (With Motion Sensor)

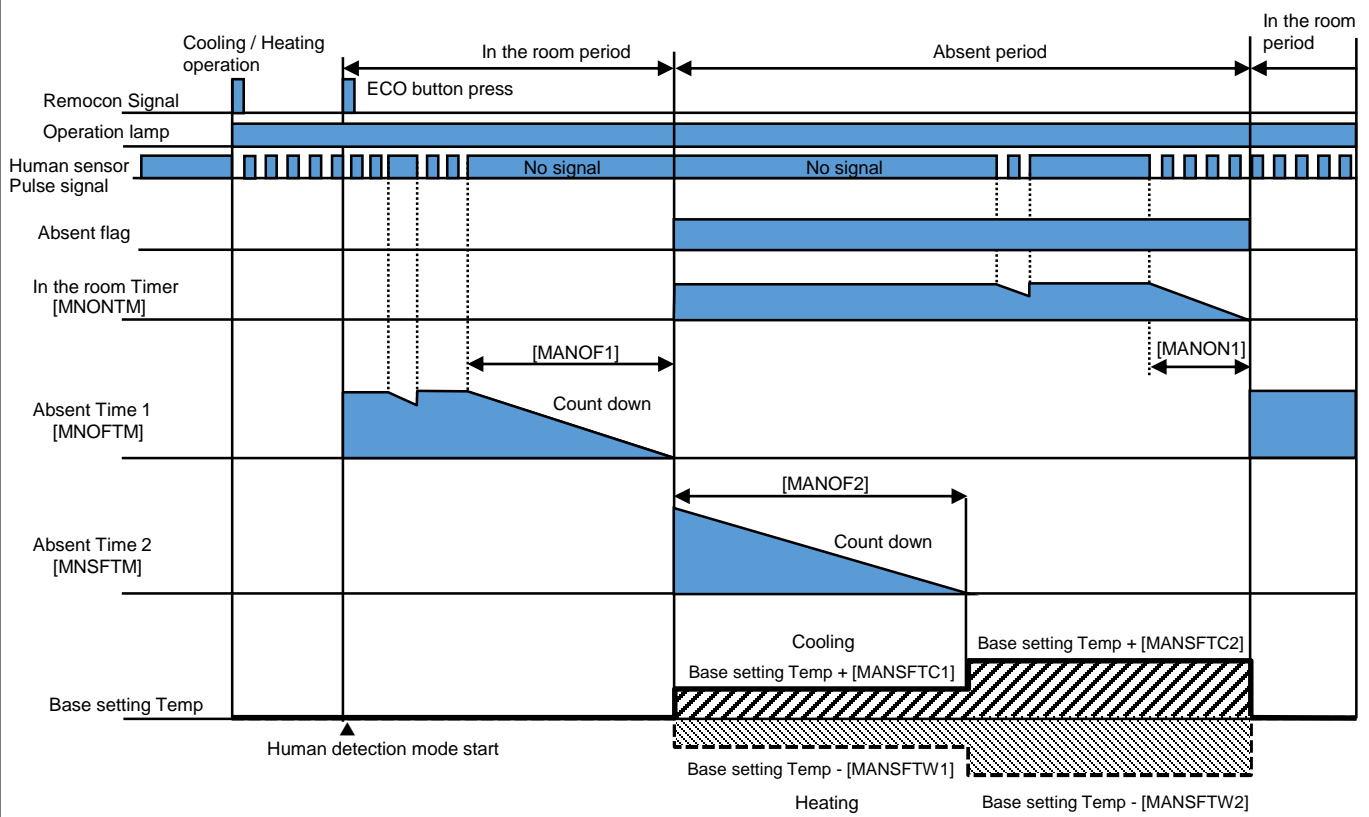

Notes :

1. ECO and POWERFUL cannot operate at the same time
2. ECO is not available during FAN operation.

REFRIGERANT CYCLE DIAGRAM

MODEL RAK-70PPD / RAC-70NPD

COOLING, DEHUMIDIFYING, DEFROSTING

OUTDOOR UNIT

INDOOR UNIT

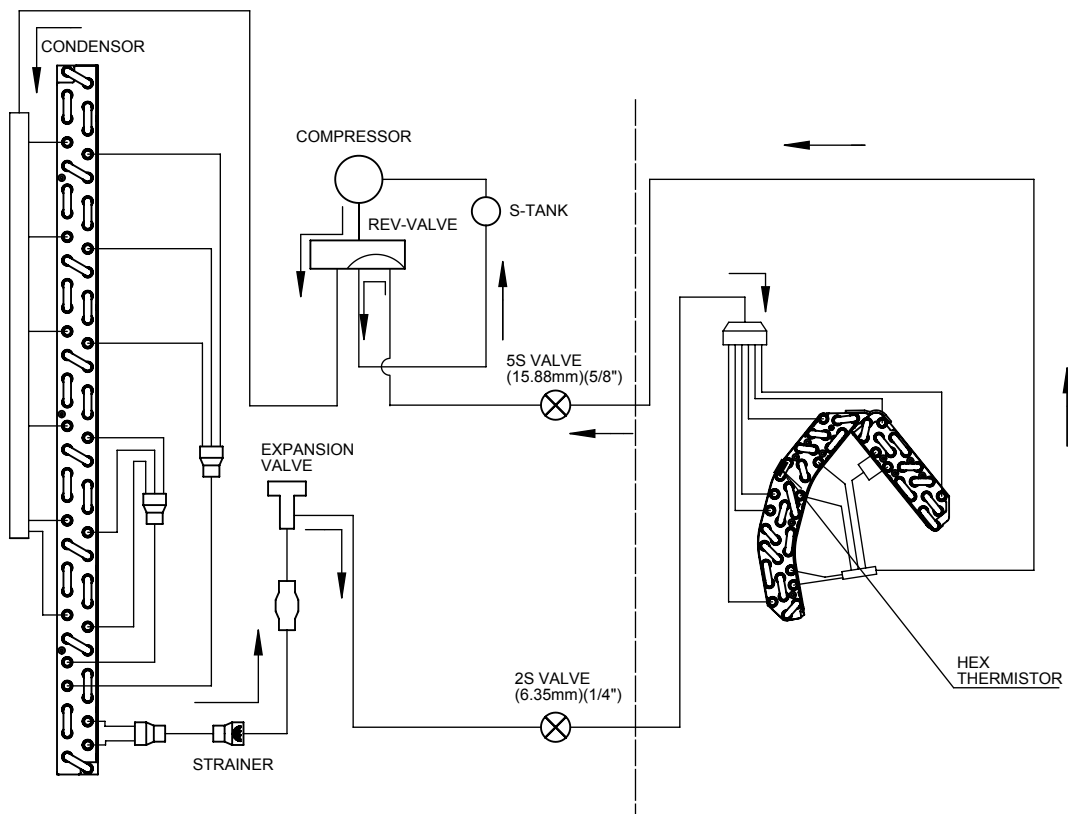

HEATING

OUTDOOR UNIT

INDOOR UNIT

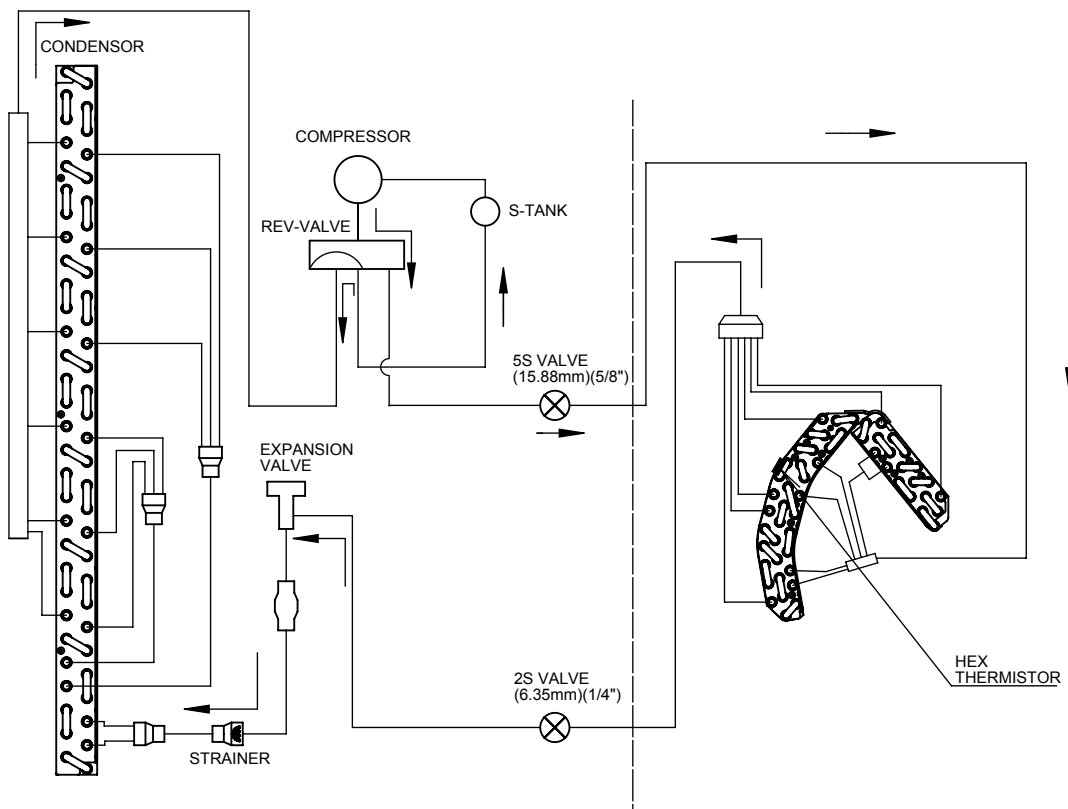

Procedure for Disassemble and Reassemble

1. Front Panel

- (1) Pull the panel by holding it both lower sides with both hands.

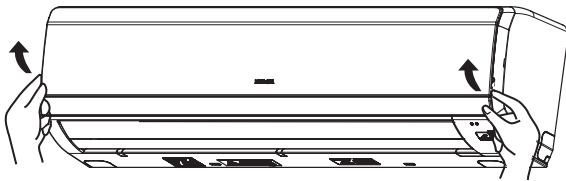

Fig. 1

- (2) When the panel opens full, pull the inner part of the right arm inward and pull the panel forward while closing it gradually.



Fig. 2

2. Front Cover

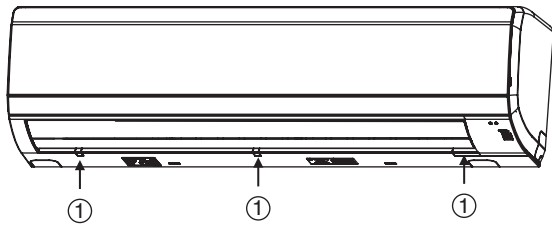

Fig. 3

- (1) Remove the caps and uncrew at lower portion of the front cover.

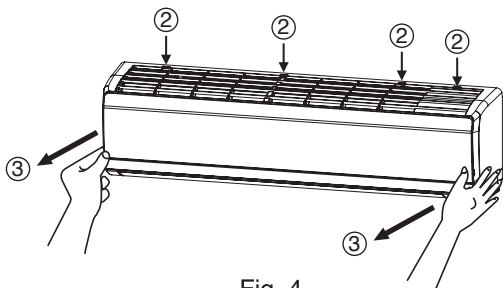

Fig. 4

- (2) Firmly press 4 hooks at top of front cover by tools until the hook release from slot.
- (3) Pull the front cover to front side.

3. Main P.W.B and Reception/Indication P.W.B

- (1) Remove each connector from the lead wire.
- (2) Remove the two P.W.B supports from the main P.W.B.
- (3) After removing the reception/indication P.W.B cover, pull the support hook at the right side of the reception/indication P.W.B and pull out the P.W.B forward.

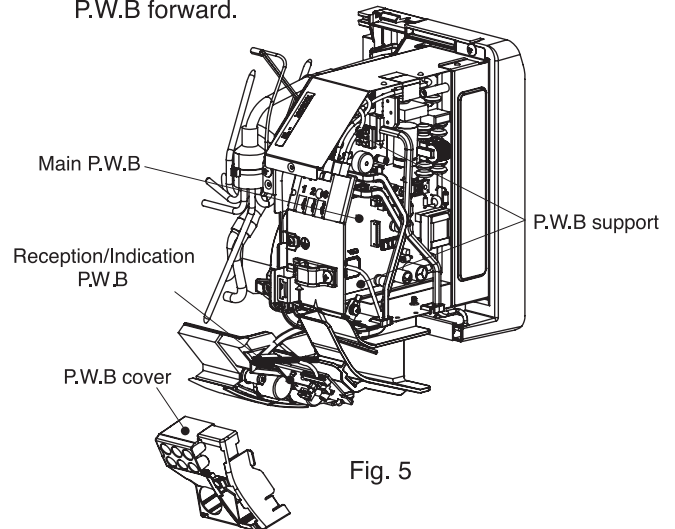

Fig. 5

4. Tangential air flow fan

- (1) Press to unhook (2 places) between drain pan and cabinet and pull the claw forward to remove the drain pan.

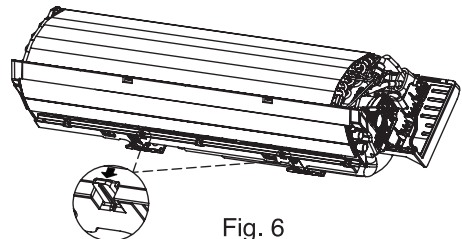

Fig. 6

- (2) Unscrew 2 portions at evaporator support and tangential fan.

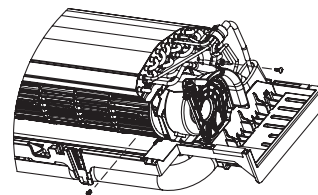

Fig. 7

- (3) Remove the locking hook of the bearing cover from the cabinet. Gently pull up the evaporator with bearing cover by holding it at lower side and pull out tangential fan.

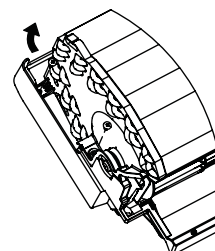
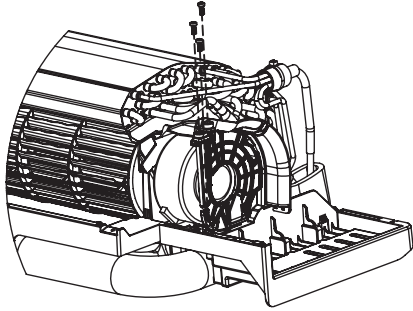

Fig. 8

(5) Fan motor

- (1) Unscrew (3 portions) between fan motor support and cabinet.



- (2) Release upper fan motor support by pressing hook to unlock and pull to the right.
 (3) Release lower fan support and remove the fan motor.

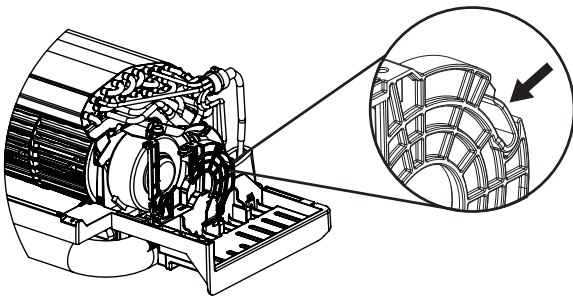

Fig. 8

1. Electrical Parts

- (1) Remove the top cover fixing screws and lift the cover to remove it.
 (2) Remove the service valve cover fixing screws and push it down to take it out.

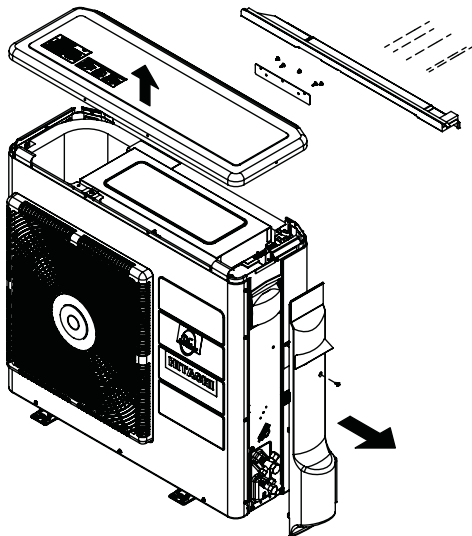

Fig. 9

- (3) Remove the electrical box cover fixing screws and remove the cover.

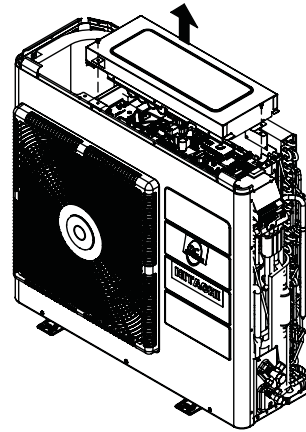

Fig. 10

2. Dismantle procedure of MAIN P.W.B

- (1) Un-insert connectors (8 places) and TAB terminal (6 places)

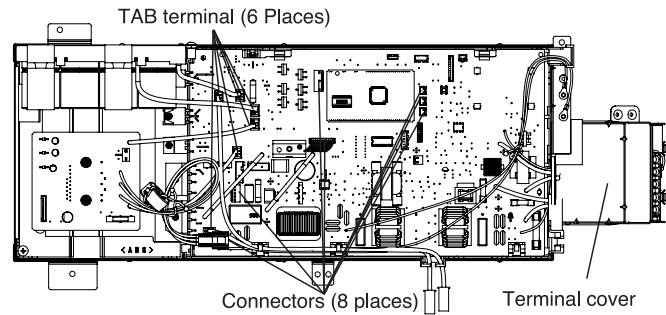
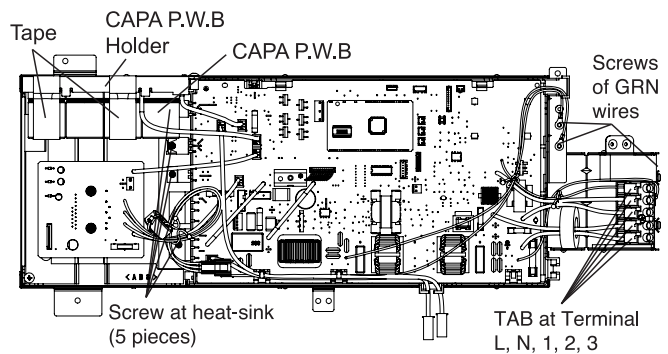

Fig. 11

- (2) Remove terminal cover, then un-insert TAB terminal at terminal L, N, 1, 2, 3.
 (3) Remove fixing screws (3 pieces) of GRN wires.
 (4) Dismantle CAPA P.W.B by removing the tape on CAPA P.W.B and take out it from the holder.
 (5) Remove fixing screws (5 pieces) at heat sink.



3. Dismantle procedure of iPM P.W.B

- (1) Un-insert connectors (1 place) and TAB terminal (2 places), and fixing screws of the P.W.B (2 pieces) at heat-sink.

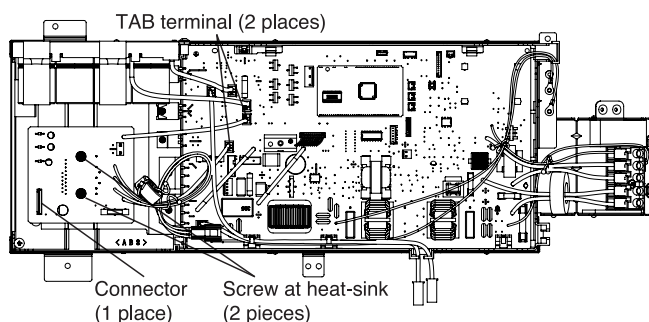

1. Control power circuit

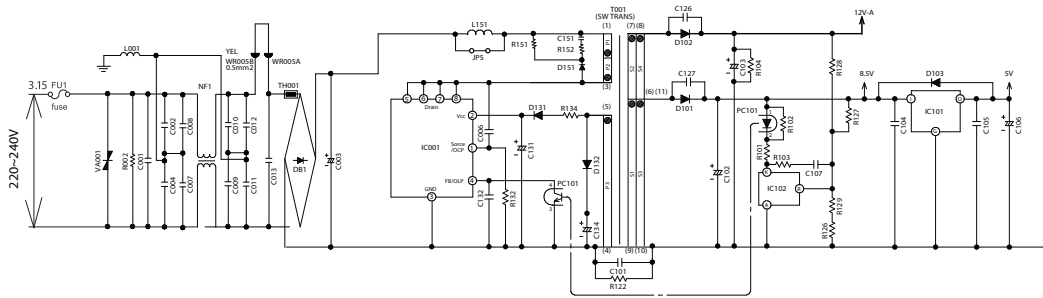

Switching power circuit

Fig. 2-1

- An AC power supply from indoor unit passes through the 3.15A fuse, varistor (VA001), and noise filter circuit and rectified and smoothed by DB1 and C003 to become a DC current 325 V. It is then supplied to indoor fan motor drive circuit, and switching power circuit.
- The switching power circuit, as controlled by IC001, drives the primary winding of the transformer (T001) to produce a specified voltage at the output winding. [The output terminal (pin ⑤) of IC001 has a switching voltage. But it changes in voltage peak and oscillation period depending on the power load. usually, the oscillation frequency when the air condition operation is about 67 kHz. In the standby state, the oscillation frequency is lowered to a level as low as 20 kHz or so to reduce the standby power.]
- The outputs of the output windings of the transformer is rectified and smoothed to become DC voltages at primary 18.5 V, 12 V, and 8.5 V respectively. The primary 18.5 V is supplied to the drive circuit of the indoor fan motor, the 12 V is supplied to each vane motor and to the drive circuits of the cleaning unit driving motor and other equipment, and the 8.5 V is adjusted to a stable 5 V by IC101 and supplied to the microcomputer peripheral circuit.

Check

If a failure in a part or circuit has produced an abnormal current in the power supply, the 3.15A fuse will melt down to prevent further damage. If the 3.15A fuse melts down, check the indoor fan motor, switching electrical circuit, and other components and replace any defective part.

Check

If an abnormally high voltage is applied to the power supply, the 3.15A fuse and varistor (VA001) will prevent further damage. If a high voltage results in the 3.15A fuse melted down, the varistor (VA001) should have deteriorated and destroyed. Therefore replace it at the same time.

Caution

The primary circuit of the transformer (T001) has a voltage to ground. Guard against electric shocks.

2. Reset Circuit

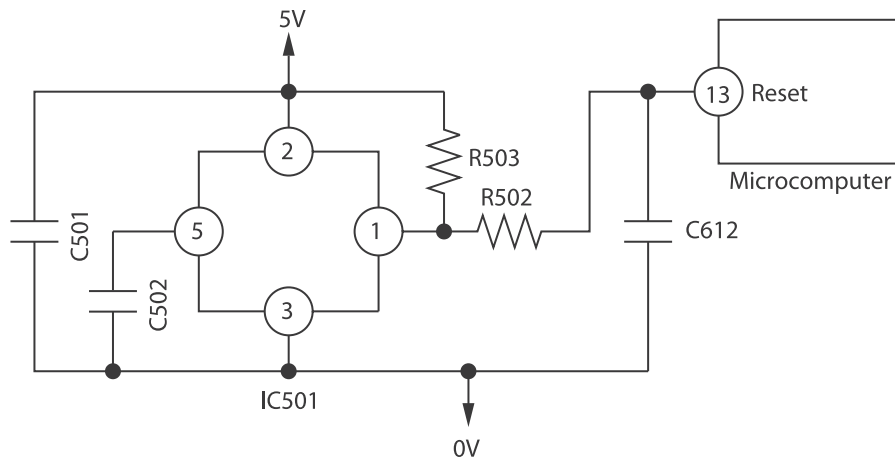

Fig. 3-1

Timing chart

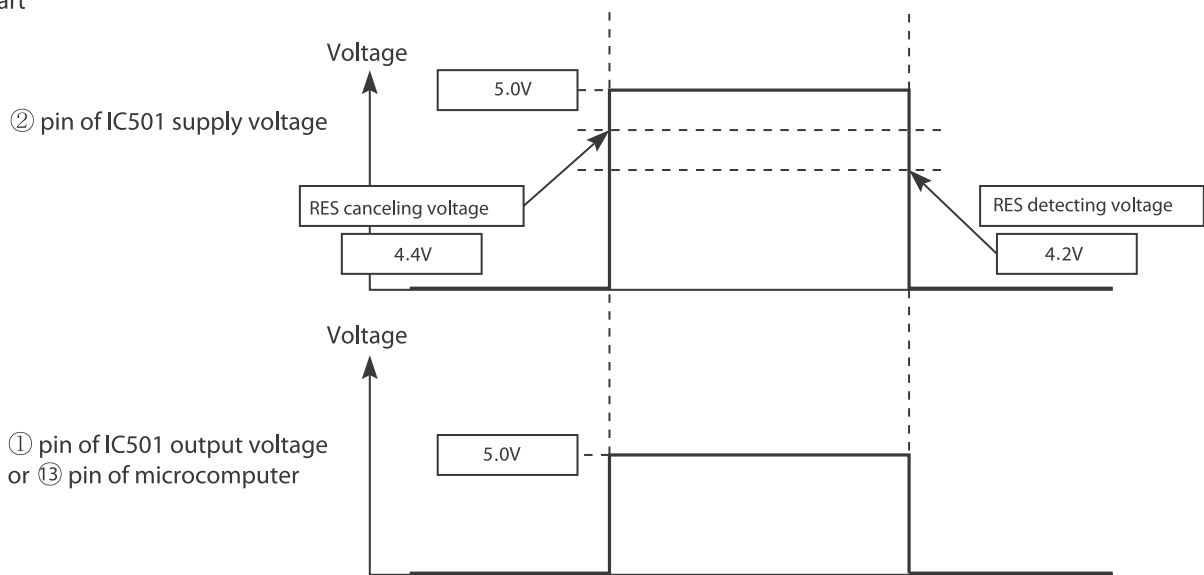

Fig. 3-2

- Reset circuit is to initialize the indoor unit microcomputer when switching ON the power or after recovering from power failure.
- Low voltage at pin ⑬ resets the microcomputer and Hi activates the microcomputer.
- Waveform of each part when switching ON the power and when shutting down is shown in the Fig. 3-2.
- After switching ON the power, ① pin of IC501 supply voltage and ⑬ pin of microcomputer becomes Hi when DC5V line rises and reaches approximately 4.4V or higher. Then, resetting will be cancelled and microcomputer starts operating.
- After shutting down the power, ① pin of IC501 supply voltage and ⑬ pin of microcomputer becomes Lo when DC5V line falls and reaches approximately 4.2V or lower. Then, the microcomputer will be in reset condition.

3. Drive circuit of the indoor fan motor

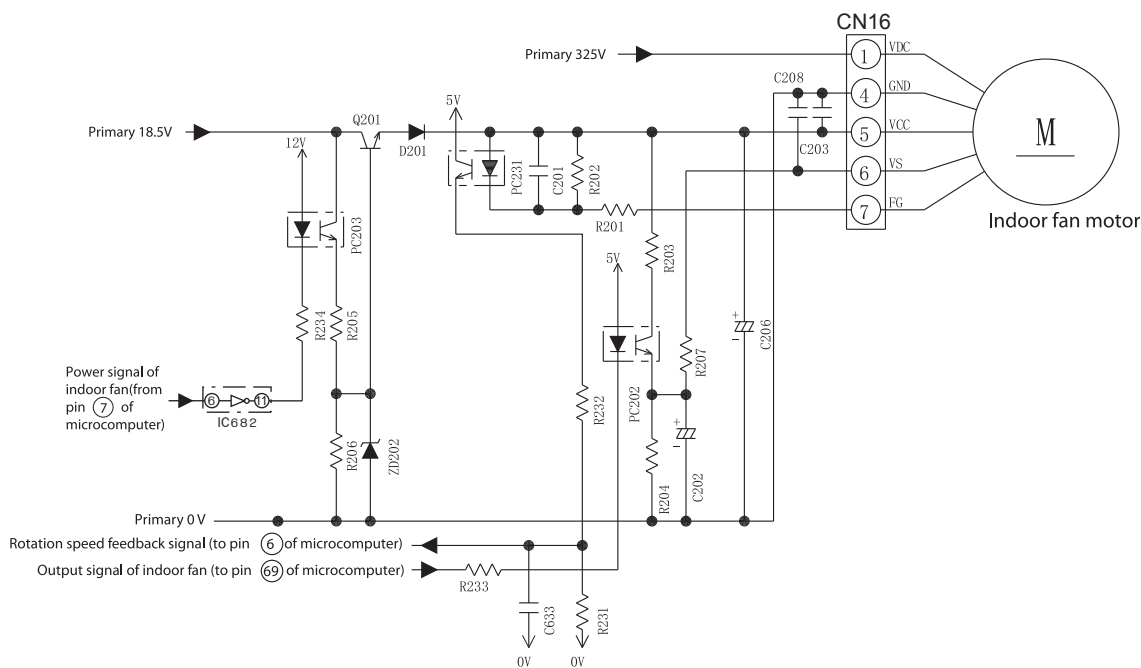
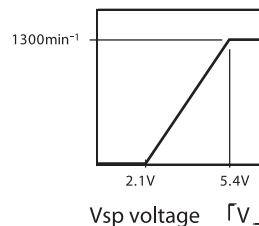

Fig. 11-1

< The circuit check (For test) >

Name	Test point	Test voltage
Motor drive power	CN16 ① pin- ④ pin	About 325V
Motor control power	CN16 ⑤ pin- ④ pin	About 15V
Motor speed signal	CN16 ⑥ pin- ④ pin	About 2-6V
Motor rotation speed debug	CN16 ⑦ pin- ④ pin	About 7.5V

< Pin 6 - Pin 4 voltage one example >



- * The voltage above is all motor operation vol. when you start the test, take care of your connector, do not touch the different pin together.
- * The voltage of pin ⑥ - pin ④, pin ⑦ - ④ maybe different from above.

* The different mode maybe have different FAN rotation speed.

< Typical circuit waveform >

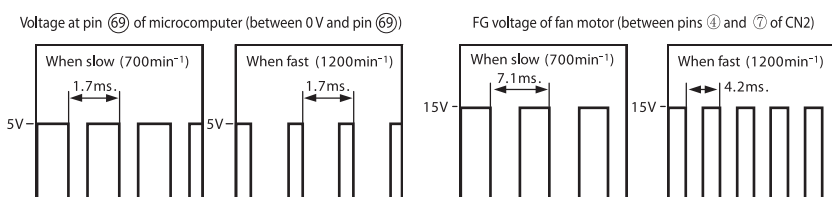

Fig. 11-2

- The indoor fan motor receives VDC (motor drive power supply), VCC (power supply for the control circuit inside the motor), and VS (speed command voltage) from CN16. The indoor fan motor returns an FG signal of a frequency that matches the rotation speed.
- VCC stabilizes the primary 18.5V power supply into 15V by using Q201 and supplies it.
- While on standby for a remote control signal, the Q201 shuts down the VCC and reduces the standby power.
- The VS receives a command voltage from the microcomputer (IC601). The VS terminal undergoes an analog voltage that matches the Lo level time ratio of the pulse signal from pin ⑥ of the microcomputer. (See Fig. 11-2.)
- The FG terminal undergoes a signal of 12 pulses per revolution of the motor shaft. By counting the pulse rate, the microcomputer (IC601) recognizes the motor speed, thereby performing feedback control.

4. Buzzer Circuit

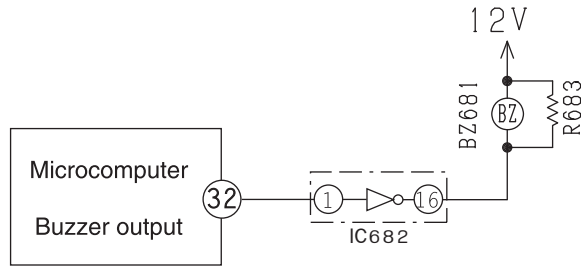

Fig.4-1 Buzzer Circuit

- When the buzzer sounds, an approx. 3.9kHz square signal is output from buzzer output pin (32) of the micro computer. After the amplitude of this signal has been set to 12Vp-p by a transistor, it is applied to the buzzer. The piezoelectric element in the buzzer oscillates to generate the buzzer's sound.

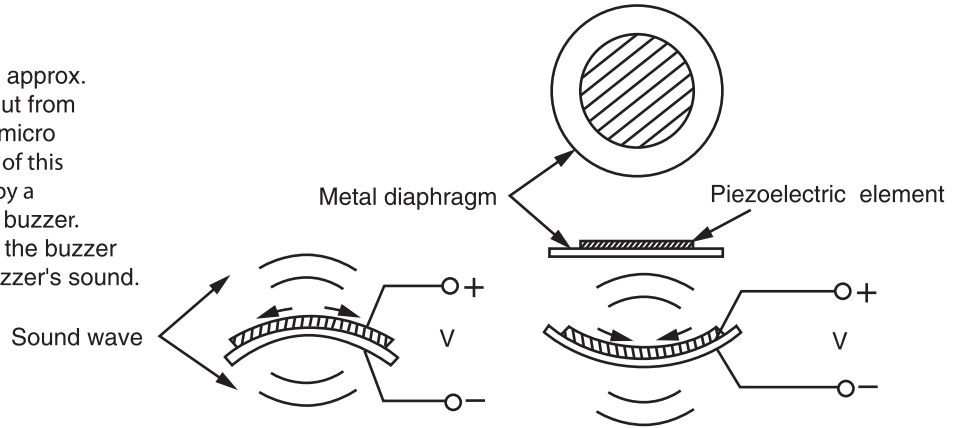

Fig.4-2 Buzzer Operation

5 . Remote control reception circuit

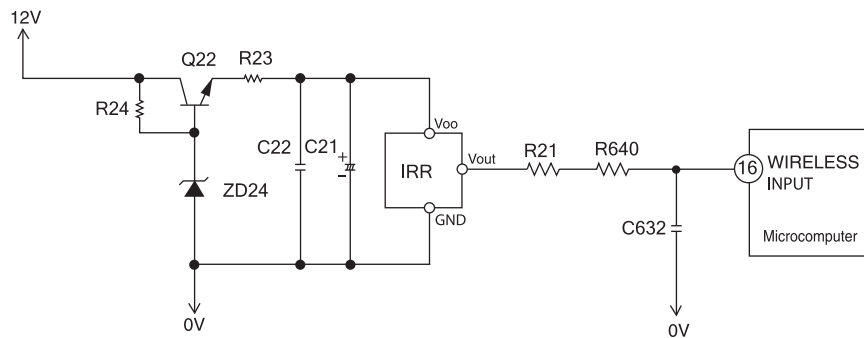

Fig.5-1

[Typical communication waveform]

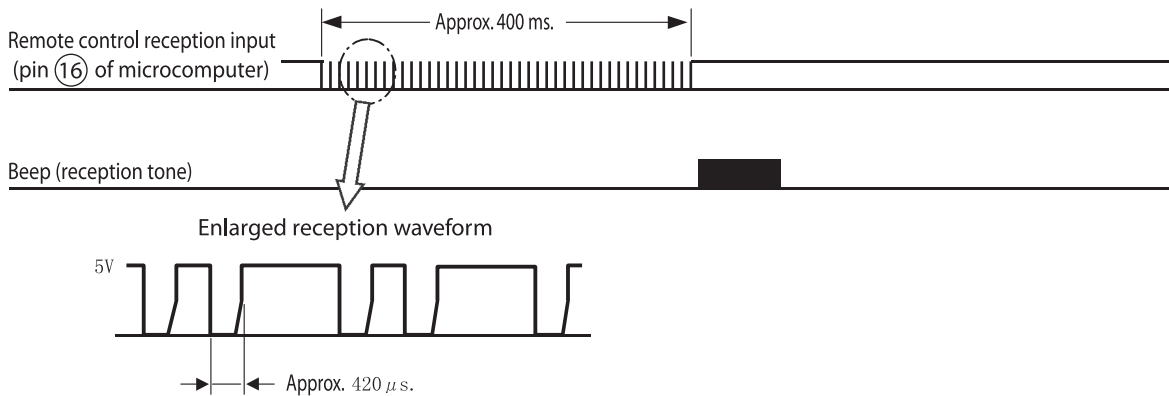
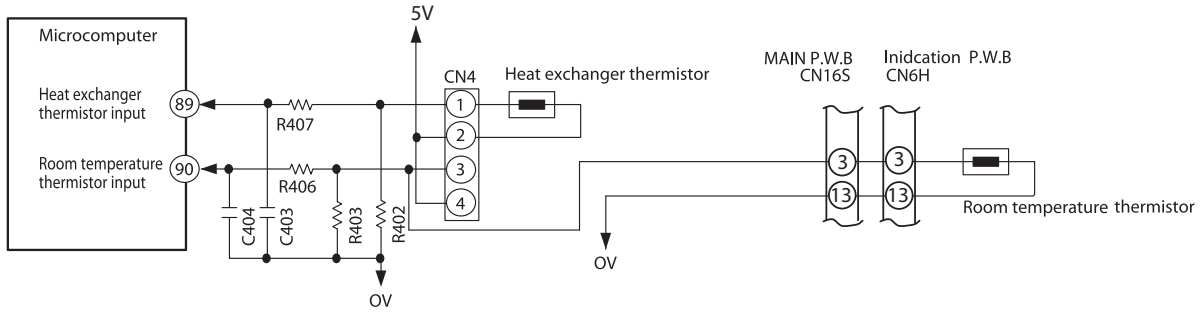

Fig. 5-2

- An infrared signal from the remote control unit is converted to an electrical signal by the remote control light-receiving unit and is received by the microcomputer. Data is transmitted as digital data 0 and 1 by changing the interval of the basic pulses at about 420 μ s.

6. Room temperature, heat exchanger thermistor circuits



- The thermistor is used for detecting the room temperature and indoor unit heat exchanger pipe temperature.
- The thermistor is a sensor that changes its resistance value according to the temperature of the element and the microcomputer (IC601) recognizes the analog voltage provided by the resistance voltage division with the fixed resistor as temperature signals.
- The relationship between the temperature of the thermistor and the circuit voltage is roughly as shown in Fig.6-1 and Fig.6-2. When it is easy to measure between the terminals of CN4 in actual measurement, use the graph of Fig. 6-3 "Thermistor both ends voltage".

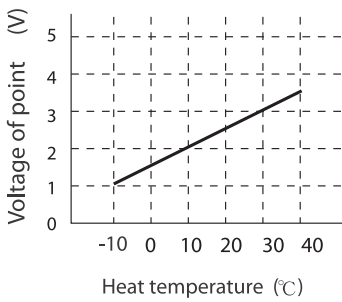

Fig. 6-1

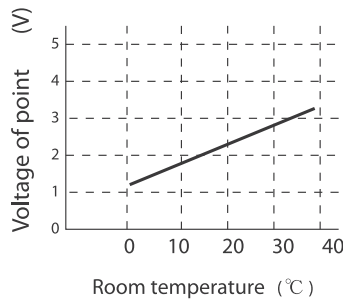

Fig. 6-2

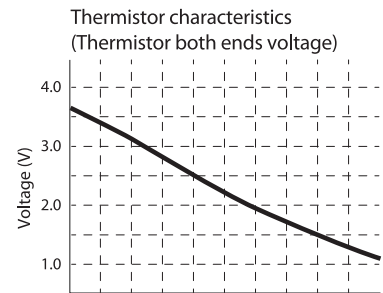

Fig. 6-3

7. Dip switch

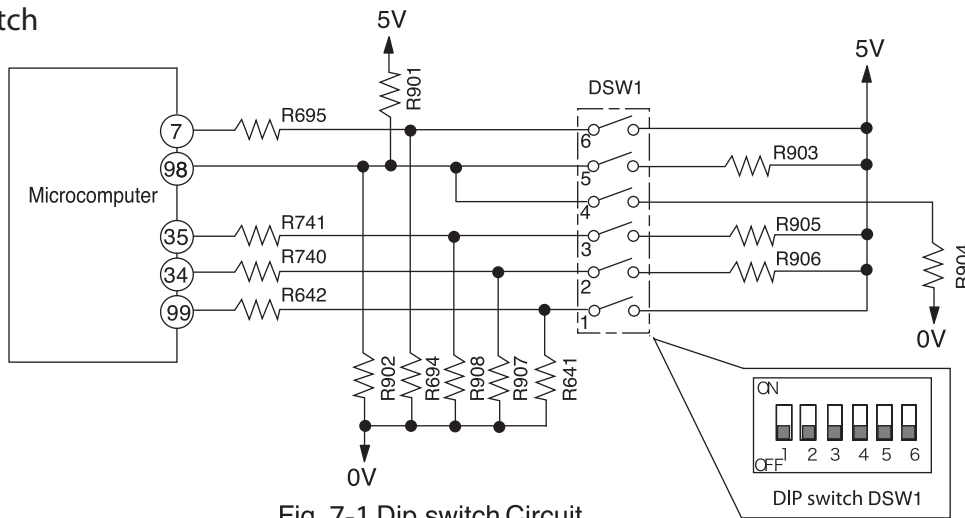

Fig. 7-1 Dip switch Circuit

- Fig. 7-1 shows the dip switch circuit; the table shown in Fig. 7-2 are function and setting position from ①-⑥ of the switch No.

SW No.	ITEM	FUNCTION					
1	AUTO RESTART	OFF*	ENABLE	ON	DISABLE		
2	CARD KEY MODE	OFF*	DISABLE	ON	ENABLE		
3	CARD KEY LOGIC SELECT	OFF*	INPUT HIGH ACTIVE	ON	INPUT LOW ACTIVE		
4	HEATING/COOLING ONLY MODE SELECT	OFF*	HEATING & COOLING	OFF	HEATING ONLY	ON	COOLING ONLY
5	HEATING/COOLING ONLY MODE SELECT	OFF*		ON		OFF	
6	REMOCON ID SELECT	OFF*	FACTORY	ON	SELECT		

Fig. 7-2 Functions of Dip switch

NOTE:

* Marking is position of shipping [FACTORY default setting]

8. Initial Setting Circuit (IC531)

- When power is supplied, the microcomputer reads the data in IC531 (E²PROM) and sets the preheating activation value and the rating and maximum speed of the compressor, etc. to their initial values.
- Data of self-diagnosis mode is stored in IC531; data will not be erased even when power is turned off.

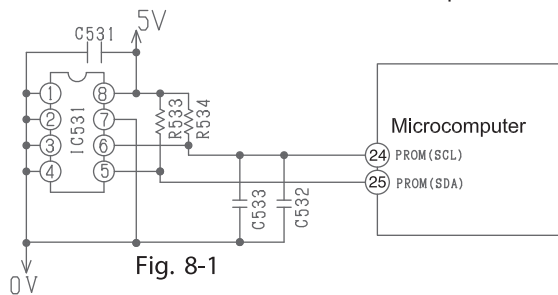

Fig. 8-1

9. Temporary Switch Circuit

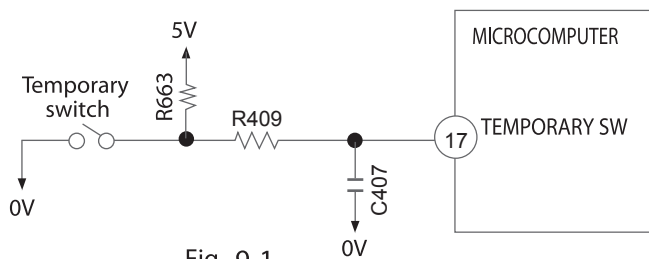

Fig. 9-1

- The temporary switch is used to operate the air conditioner temporarily when the wireless remote control is lost or faulty.
- The air conditioner operates in the automatic mode by pressing the temporary switch. If the power switch is set to OFF then ON it also operates in the automatic mode when the temporary switch is pressed.

10. Infrared human presence sensor circuit

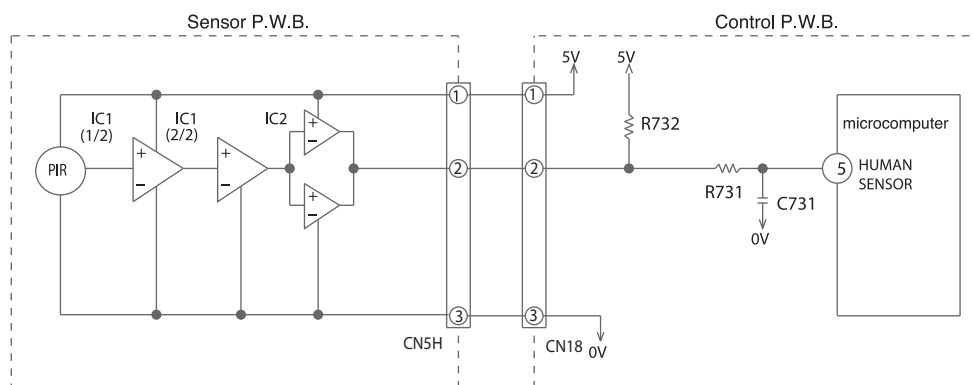
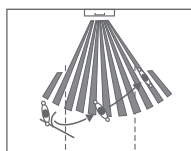

Fig.10-1

- With the infrared sensor, the air conditioner can detect the activity level in a room and adjust the temperature and humidity automatically, thus achieving the purpose of energy saving.
- When the activity level in a room is detected, the infrared sensor will be in operation. And a low-voltage output from the infrared sensor P.W.B. will be magnified by the amplifier comparator and be transformed the digital signal to microcomputer (IC601).



The infrared sensor output is [Hi] when the activity level is not detected. On the contrary, output is [Lo].

The area in front of the indoor unit is divided into 3 parts (the left area, central area and right area). According to the 3 areas, the infrared sensor detects the position of people.

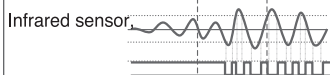

The left-hand chart is displaying the operation of the infrared sensor when detecting the person moving from the left area to the right.

Check

If a cable poorly inserted in the indoor terminal board or some other failure overheats the terminal board and the temperature fuse of the terminal board blows out, the power to the indoor communication circuit will be shut down to stop the communications function. (In that case, the failure will be displayed by the timer lamp blinking 3 times.)

Check

If communication fails between the indoor and outdoor units for some reason, the product will give a self-diagnosis display either by "the timer lamp blinking 3 times" or "the timer lamp blinking 12 times" depending on the cause.

Indoor/Outdoor communication fault circuit judgement

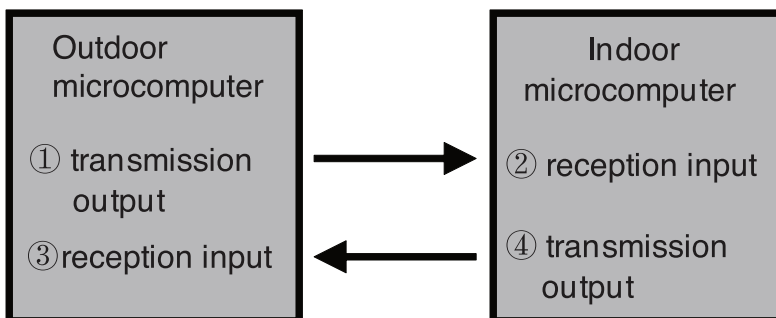

1. Failure happen during unit running

- 【If ① failure】 Outdoor: LD301 blinking 9 times / Indoor: no failure display
- 【If ② failure】 Outdoor: LD301 blinking 9 times / Indoor: the timer lamp blinking 3 times
- 【If ③ failure】 Outdoor: LD301 blinking 9 times / Indoor: no failure display
- 【If ④ failure】 Outdoor: LD301 blinking 9 times / Indoor: the timer lamp blinking 3 times

2. Failure happen during standby mode but outdoor unit not yet enter hibernation mode

- 【If ① failure】 Outdoor: LD301 blinking 9 times / Indoor: the timer lamp blinking 12 times
- 【If ② failure】 Outdoor: LD301 blinking 9 times / Indoor: the timer lamp blinking 3 times
- 【If ③ failure】 Outdoor: LD301 blinking 9 times / Indoor: the timer lamp blinking 12 times
- 【If ④ failure】 Outdoor: LD301 blinking 9 times / Indoor: the timer lamp blinking 3 times

3. Failure happen during standby mode but outdoor unit already enter hibernation mode

- 【If ① failure】 Outdoor: no failure display / Indoor: the timer lamp blinking 12 times
- 【If ② failure】 Outdoor: no failure display / Indoor: the timer lamp blinking 3 times
- 【If ③ failure】 Outdoor: no failure display / Indoor: the timer lamp blinking 12 times
- 【If ④ failure】 Outdoor: no failure display / Indoor: the timer lamp blinking 3 times

When outdoor unit is in hibernation mode, outdoor microcomputer is off, so the outdoor unit can't display the failure.

11 . Indoor/outdoor communication circuits

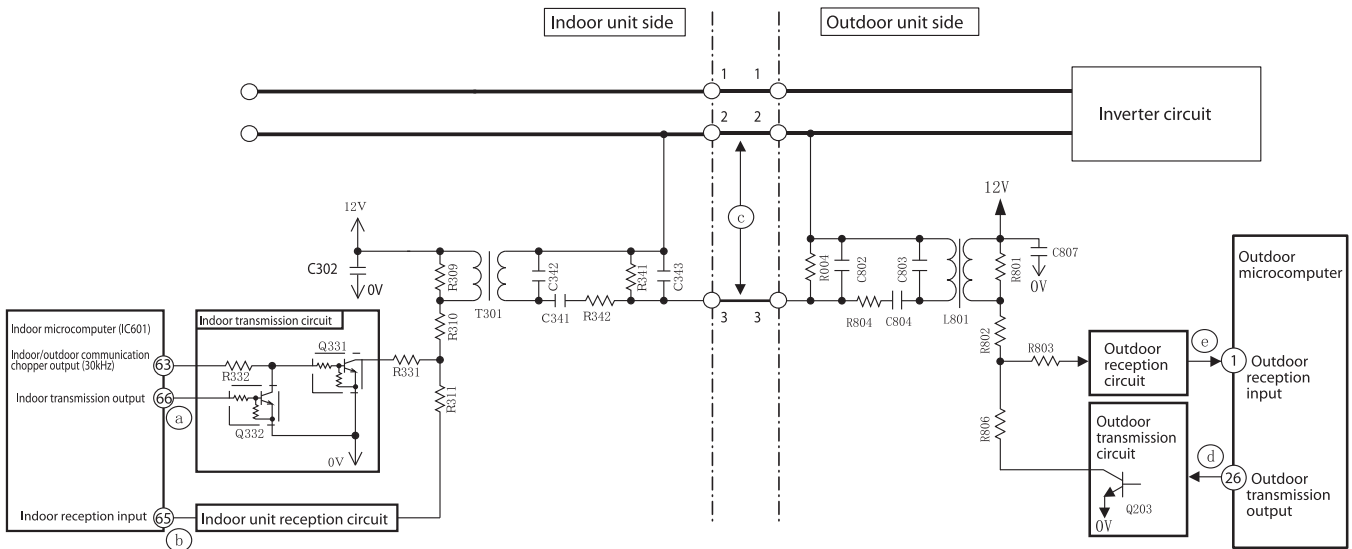

Fig. 11 -1

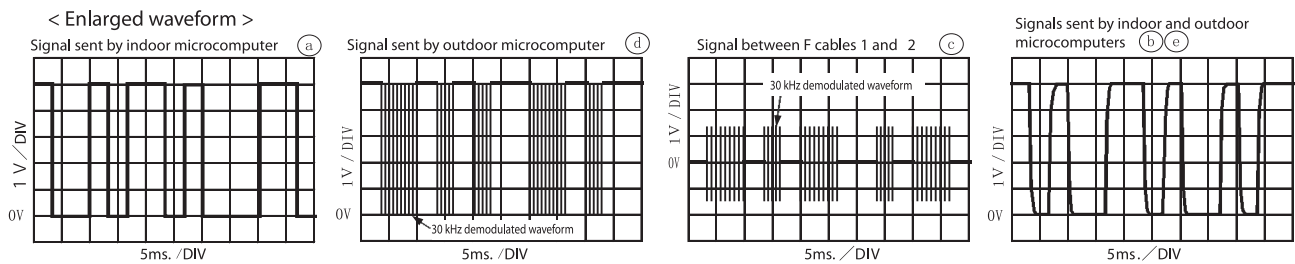
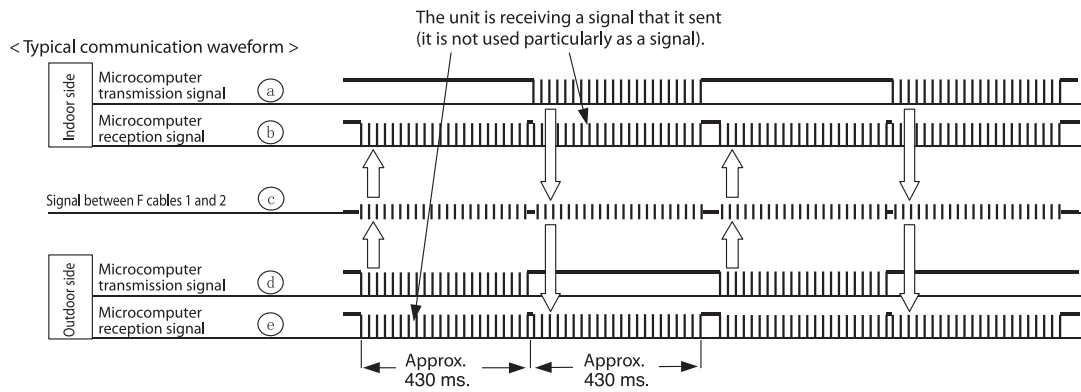

Fig. 11 -2

- Indoor and outdoor communications are conducted by using lines 2 and 3 of F cable. Line 2 of F cable is shared with a transmission channel that powers the outdoor unit.
- Data communicated between the indoor and outdoor units are outputted from the microcomputer as serial signals and are transmitted as demodulated by a 30 kHz carrier wave. (Both the indoor and outdoor microcomputers directly output a signal demodulated at 30 kHz.)

12. Stepping motor drive circuit

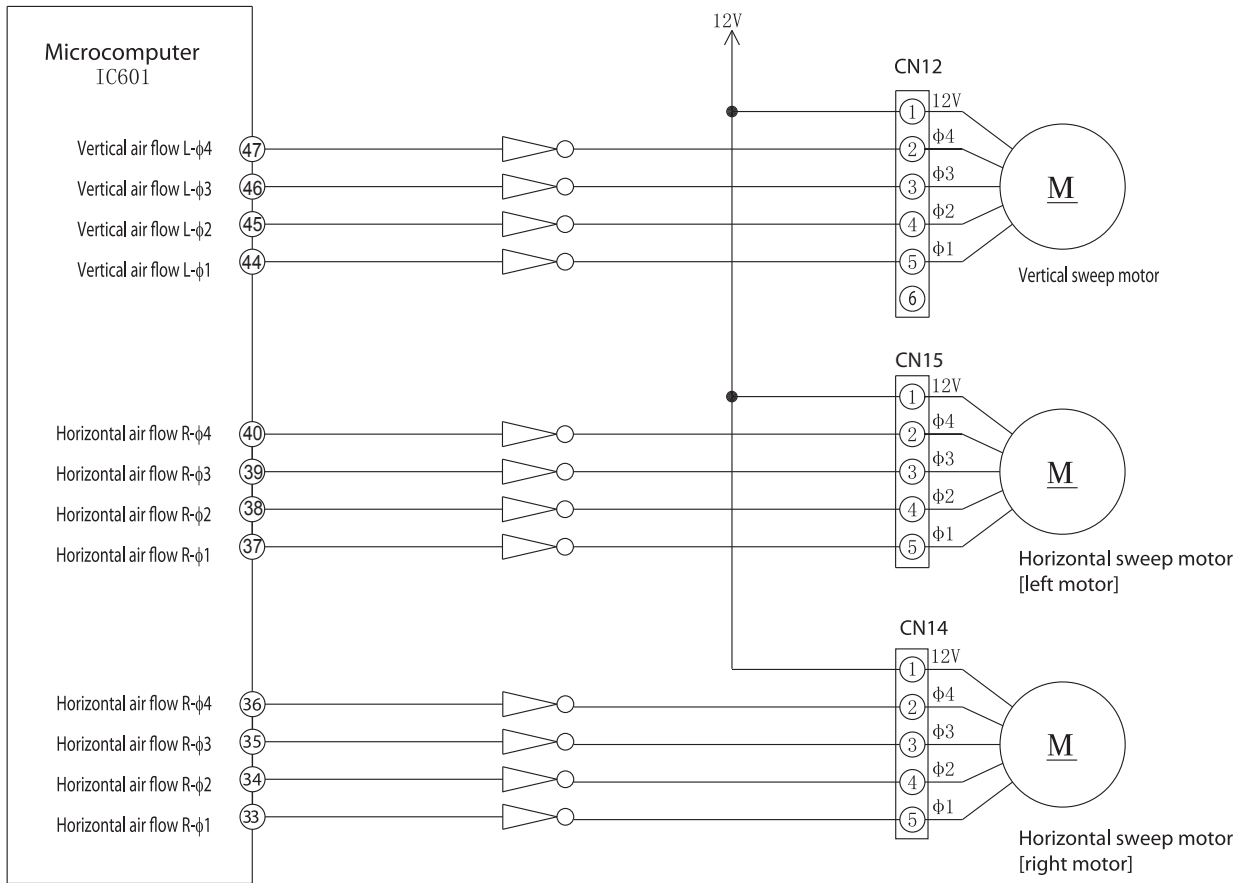

Fig. 12-1

[Connector circuit waveform while the motor runs]

Voltage waveforms of different phases as viewed from the OV line while the motor rotor is turning counterclockwise as viewed from the shaft side

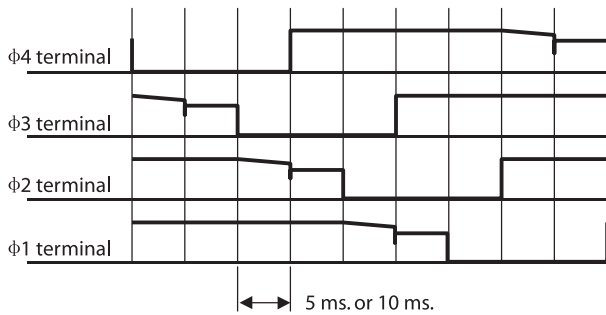

Fig. 12-2

- Each stepping motor runs as excited in 1 or 2 phases at 100 PPS or 200 PPS.
- The excitation pattern passes the microcomputer (IC601) and then the driver IC and excites the coil of each stepping motor.
- Some models not need to install the horizontal sweep motor.

13. Run status and alarm signal output circuit

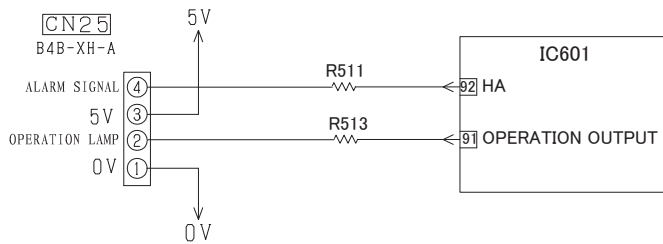

Fig.13-1

Fig.13-1 is the control circuit of run status and signal output in main PWB. The pin ② of CN25 is used to show run status and the pin ④ of CN25 is used to warn people when failure occurrence. If customer want to use this function, need to use the adapter(sold separately) to achieve it. the adapter is optional and the detail circuit refer to following circuit.

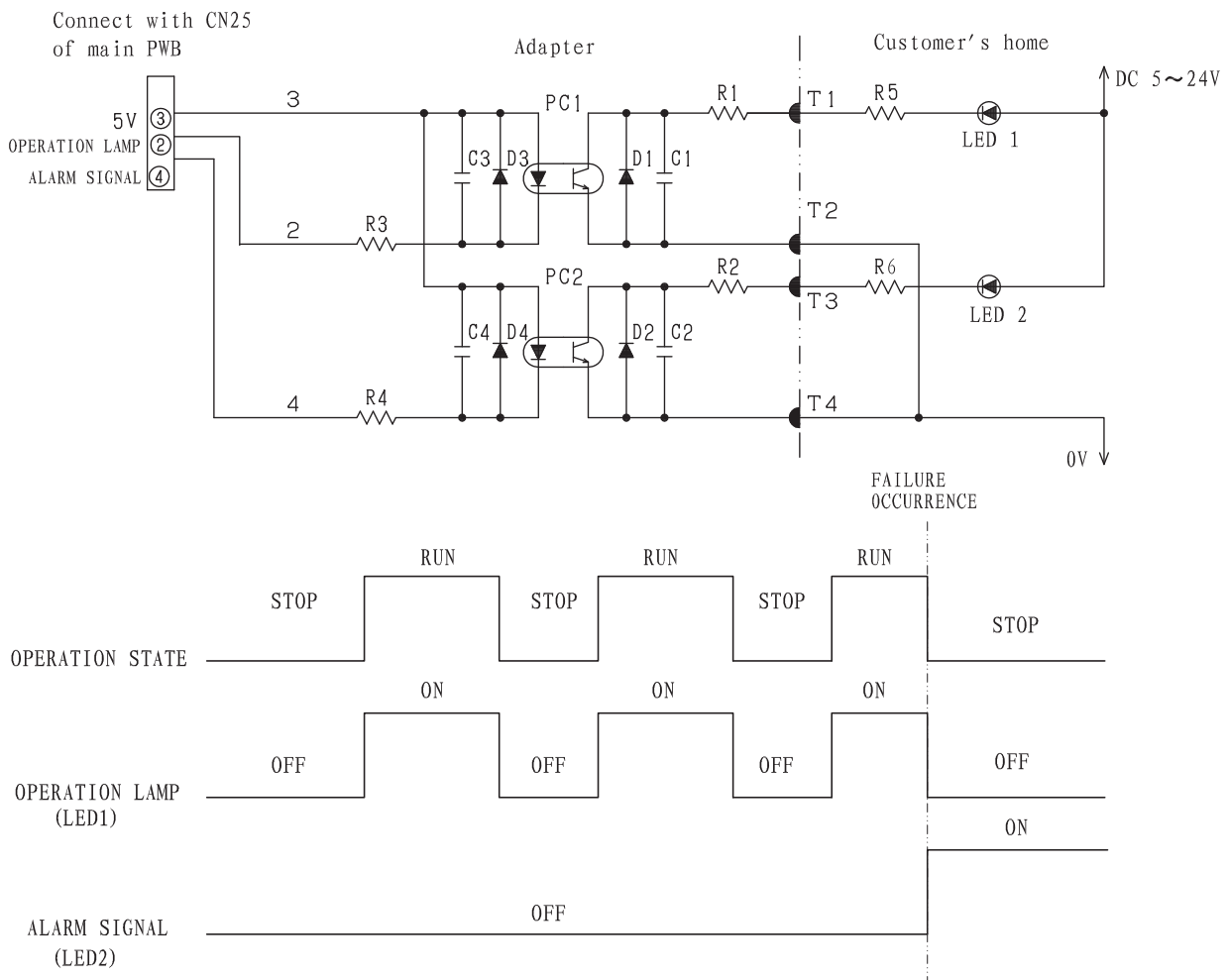

Fig.13-2

LED1 is on When air-condition is running and is off When air-condition is stopping. We can know the status of air-condition by LED1. LED2 is off When air-condition in normal condition and is on when air-condition in failure occurrence, we can repair it in time. The brightness of the lamp (LED1, LED2) can be determined by adjusting the resistance (R5, R6) value.

※ The adapter must be used because of noise interference. The noise will cause air-condition failure. the voltage from customer's home supply to adapter must be in the 5~24V, the current is less than 10mA. If the voltage is lower than 5V, optocouplers will not be action; once the voltage is higher than 24V, optocouplers adapter will be damaged.

DESCRIPTION OF MAIN CIRCUIT OPERATION

MODEL RAC-70NPD

1. Power Circuit

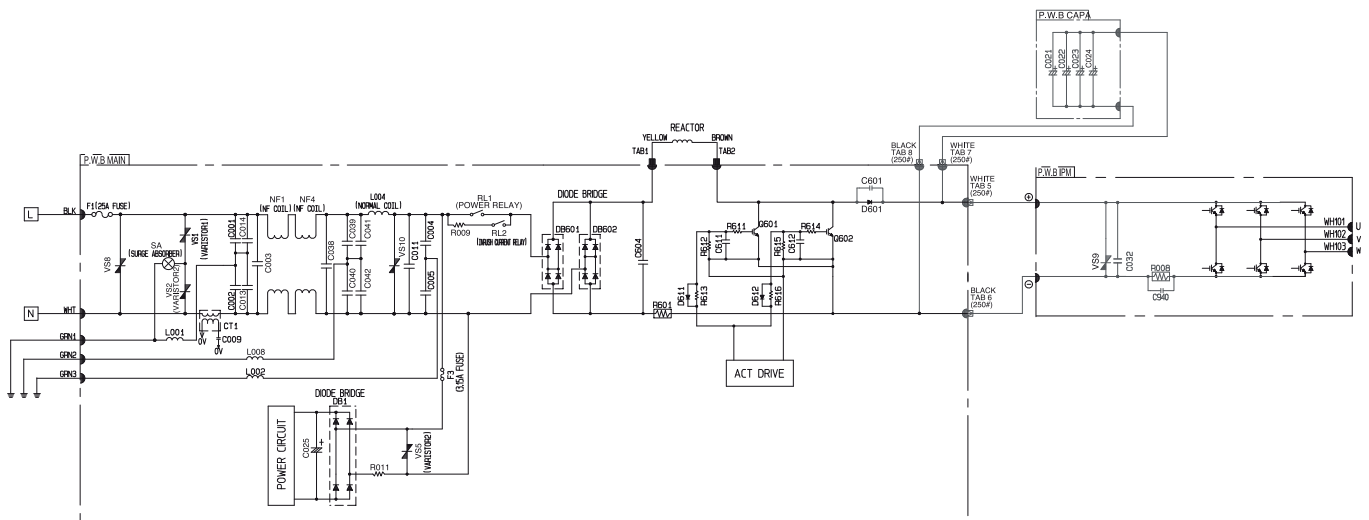

Fig 1-1

※ This circuit full-wave rectifies 240VAC applied between terminals L and N and boosts it to a required voltage with the IPM to create a DC voltage.

The voltage become 320-360V when the compressor is operated.

※ Importance component

(1) Intelligence Power Module (IPM)

A module that constitute by an inverter part.

<Reference>

※ In case of Intelligence Power Module malfunction or connection failure immediately after compressor starts, its may stop due to error of [abnormal low speed], [switching failure],[Ip stop] and others.

(2) Diode Stack (DB1, DB601, DB602)

These rectify the 240VAC from terminal L and N to a DC power supply.

<Reference>

※ If diode stack (DB601, DB602) are faulty, DC voltage may not be generated and the compressor may not operate at all. Also be aware that the 3.15A fuse might have blown.

(3) Smoothing capacitors (C021-C024, 500 μ F 450V)

<Reference>

※ This smoothes (averages) the voltage rectified by the diode stack.

(4) IGBT to improve efficiency (Q601, Q602)

<Reference>

※ It will improve the efficiency during compressor load become heavy when current flow thru the chopper period of Q601, Q602

2. Power circuit (Low voltage)

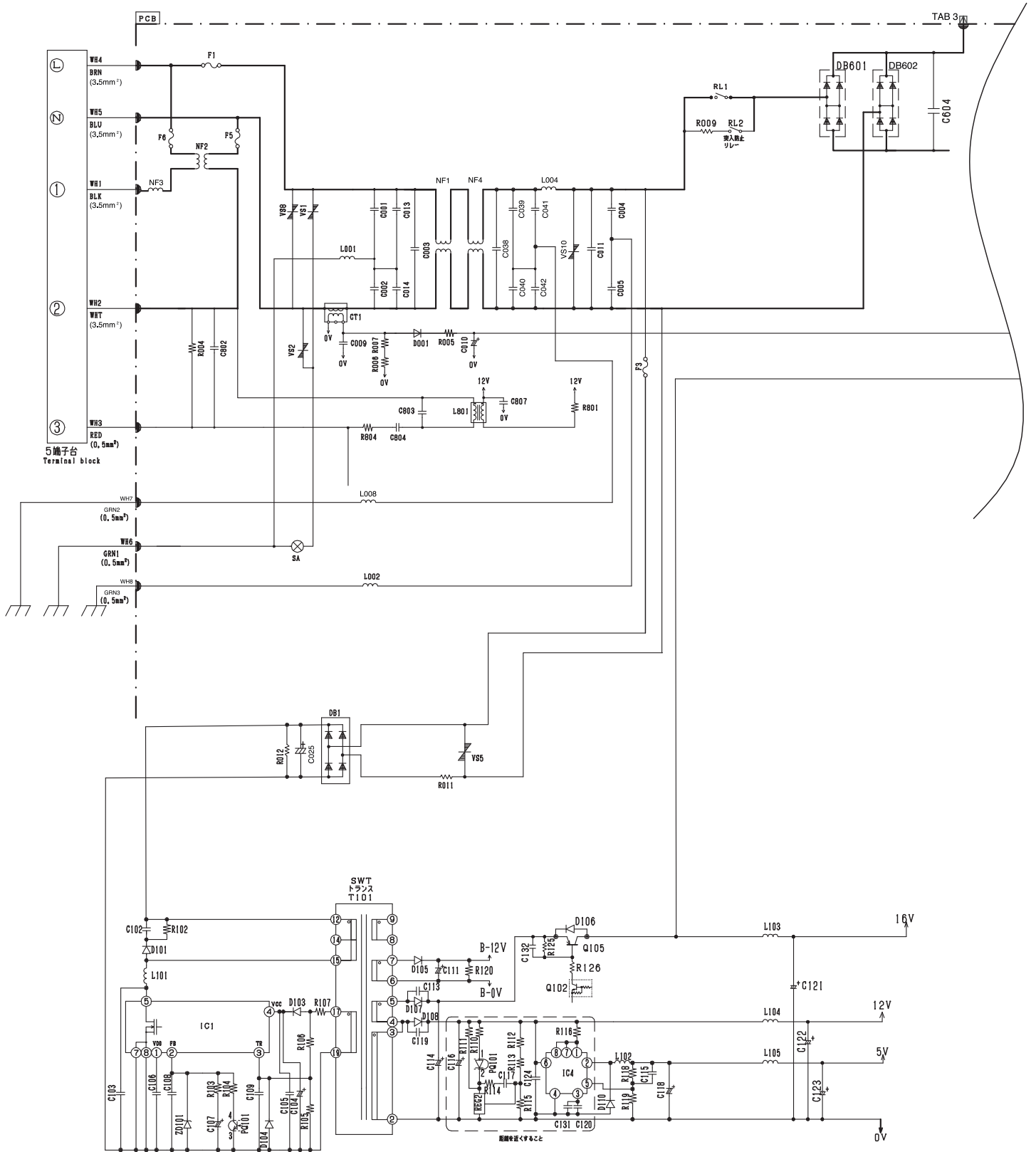

Fig. 2-1

- The 240V AC voltage is rectified to DC voltage (B-12V,16V,12V,5V) pass through switching control IC (IC1), switching transformer.
 - (1) B-12V Power supply for electrical expansion valve.
 - (2) 16V Power supply for IPM driver circuit of compressor and fan motor, IGBT action.
 - (3) 12V Power supply for 4 way valve relay, power relay, in rush current relay, motor current amplification,
 - (4) 5V Power supply for microcomputer, peripheral circuits.

Main parts

(1) C001,C002,C003,C004,C005,C011,C013,C014, C038, C039, C040, C041, NF1, NF2, NF3, NF4

These absorb electrical noise generated during operation of compressor and also absorb external noise entering from power line to protect electronic parts.

(2) Surge Absorber, Varistor1,2,5,8,10

These absorb external power surge.

(3) IC4

DC/DC converter IC (DC12V → DC5V).

3. P.W.B. for power circuit

Voltage specification of power circuit as shown in below table.

<Checking point>

Output	Spec	Main load	Measuring point	Example of possible failure mode.
5V O/P	$5 \pm 0.4V$	Micon, Thermistor	Tester \oplus : L105 (5V) Tester \ominus : R119 (0V)	Outdoor not operate, no blinking indication
12V O/P	$12 \pm 0.5V$	Micon, IC2, 3, 4 Relay circuit	Tester \oplus : L104 (12V) Tester \ominus : R119 (0V)	Outdoor not operate, no blinking indication
16V O/P	$15.5^{+1.5V}_{-1.0V}$	IPM for Comp IPM for DC fan	Tester \oplus : L103 (16V) Tester \ominus : R119 (0V)	Stop : LD301 2, 3, 4 or 12 times blinking
B-12V O/P	$13^{+2.5V}_{-1.0V}$	Expansion valve	Tester \oplus : R418 (B-12V) Tester \ominus : R120 (B-0V)	Stop : LD301 5 times blinking (related to refrigerant cycle error)

※ Power circuit for P.W.B can consider normal if the result is satisfied with above specification.

4. Reversing valve control circuit

This model reversing valve control used to control the relay ON/OFF of the reversing valve, and also control the coil of the reversing valve ON/OFF.

The relay ON/OFF has different type when in the different operation mode.

You can see each operation mode as follows. If the reversing valve not connected or all the condition not the same as follow, it may be something wrong with the reversing valve circuit.

Point operation mode		micon (28 pin - 0V	HIC (28 pin - 0V	CN2①- CN2④
		Cooling	Usual cooling	Hi
Heating	Usual heating	Lo	12V	AC240V
	Defrost	Hi	0V	0V

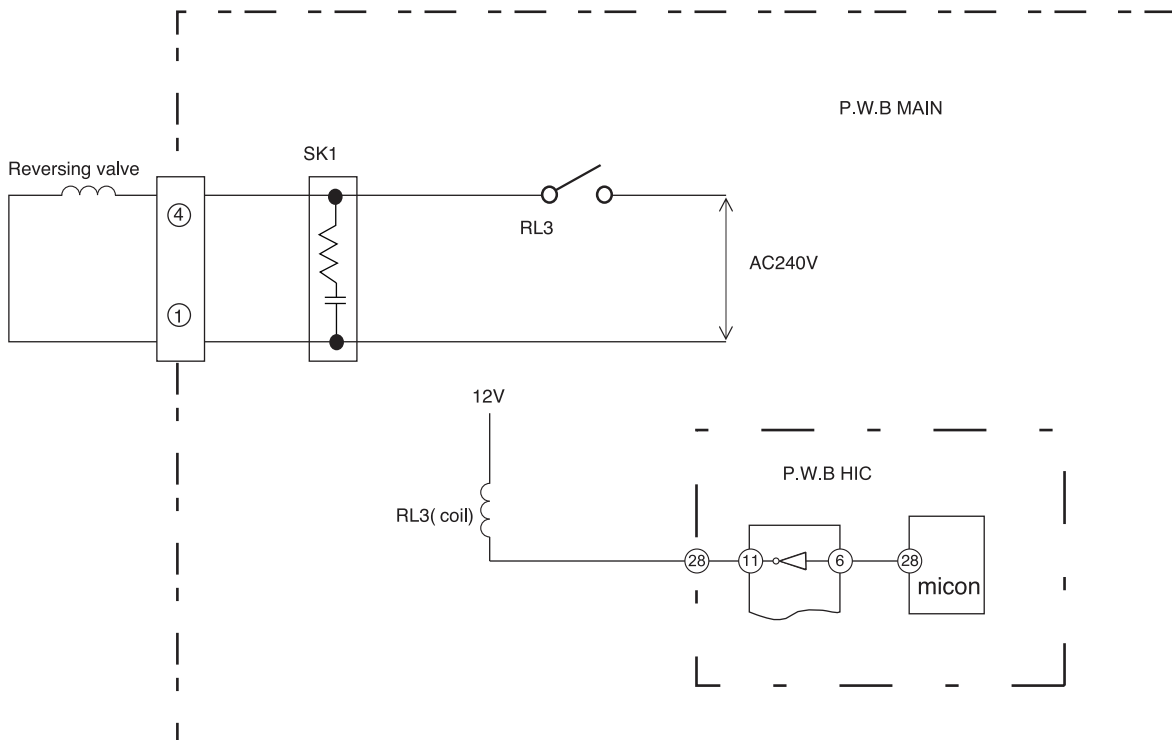

Fig.4-1

5. Temperature Detection Circuit

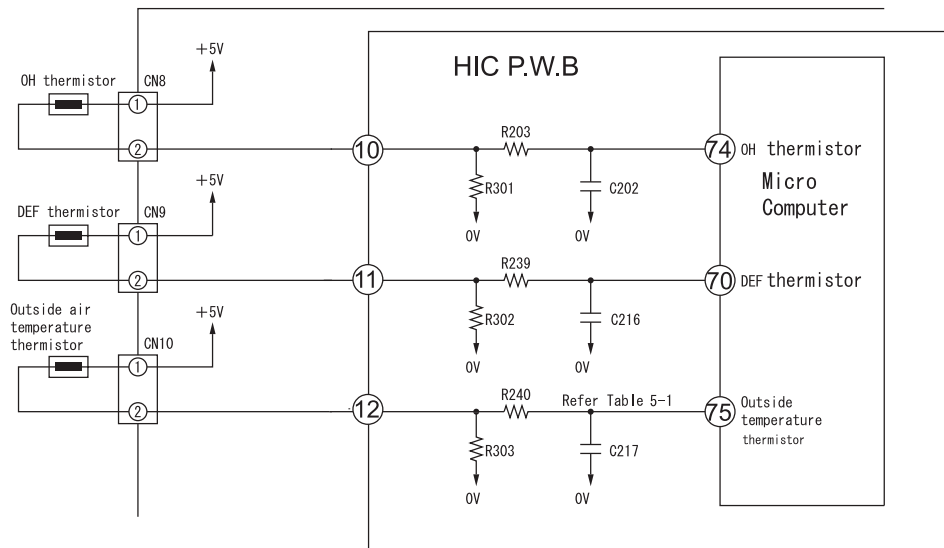

Fig.5-1

- OH thermistor circuit detect the temperature at the surface of compressor head, DEF thermistor circuit detect the defrosting operation temperature.
- A thermistor is a negative resistor element which has characteristics that the higher(lower) the temperature, the lower(higher) the resistance.
- When the compressor is heated, the resistance of the OH thermistor becomes low and $\oplus 5V$ is divided by OH thermistor and R301 and the voltage at pin ⑦④ of microcomputer.
- Compare the voltage at microcomputer pin ⑦④ and setting value stored inside. If the value exceed the set value, microcomputer will judge that the compressor is overheated and stop the operation.
- When frost is formed on the outdoor heat exchanger, the temperature at the exchanger drops abruptly. Therefore the resistance of the DEF thermistor becomes high and the voltage at pin ⑦⑩ of micro computer drops. If this voltage becomes lower than the set value stored inside, microcomputer will enter the defrost control.
- During defrost operation, the microcomputer will transfer the defrosting condition command to indoor unit via SDO pin of interface of IF transmission output.
- The microcomputer read the outdoor temperature by Outside Air thermistor and transfer it to the indoor unit, thus controlling the compressor rotation speed according to the set value in the EEPROM of indoor unit and switching the operation mode (outdoor fan on/off etc.) to DRY mode.

Below table show the typical values of outdoor temperature in relation to the voltage.

Table 5-1

Outside Air Temperature (°C)	-10	0	10	20	30	40
Voltage at both side of R303 (V)	1.19	1.69	2.23	2.75	3.22	3.62

<Reference>

When the thermistor is open, open condition or disconnect, microcomputer pin 70, 74, 75 are approx. 0V; When thermistor is shorted, they are approx. 5V and LD301 will blink as below table:-

Table 4-2

Thermistor Condition	Thermistor	LD 301 Blinking		
		OH Thermistor	Outdoor Thermistor	Defrost Thermistor
Short		6 Times Blinking	7 Times Blinking	7 Times Blinking
Open		7 Times Blinking	7 Times Blinking	7 Times Blinking

6. Electric expansion valve circuit

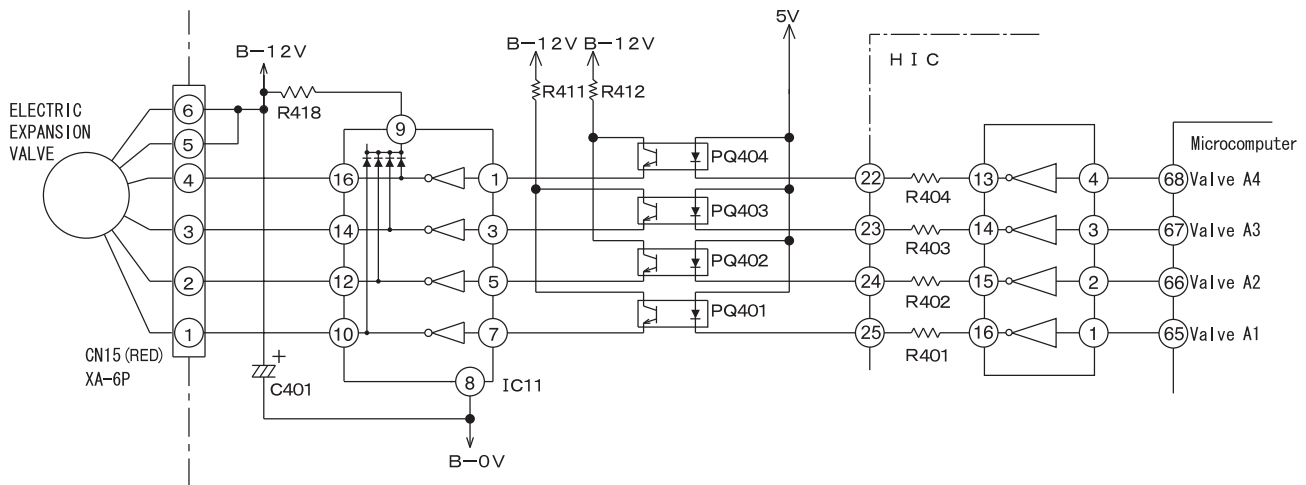

Fig. 6-1

- The electric expansion valve is driven by DC12V. Power is supplied to 1 or 2 phases of 4-phase winding to switch magnetic pole of winding in order to control the opening degree.
- Relationship between power switching direction of phase and open/close direction is shown below. When power is supplied, voltages at pins ④ to ① of CN15 are about 0.9V and 12V when no power is supplied. When power is reset, initial operation is performed for 10 or 20 seconds. During initial operation, measure all voltages at pin ④ to ① of CN15 by using a multimeter. If there is any pin with voltage that has not changed from 0.9V or 12V, expansion valve or microcomputer is broken.
- Fig.6-2 shows logic waveform when expansion valve is operating.

Table 6-1

CN15 pin no.	Wire	Drive status							
		1	2	3	4	5	6	7	8
①	WHT	ON	ON	OFF	OFF	OFF	OFF	OFF	ON
②	YEL	OFF	ON	ON	ON	OFF	OFF	OFF	OFF
③	ORG	OFF	OFF	OFF	ON	ON	ON	OFF	OFF
④	BLU	OFF	OFF	OFF	OFF	OFF	ON	ON	ON

Operation mode
 1→2→3→4→5→6→7→8 VALVE CLOSE
 8→7→6→5→4→3→2→1 VALVE OPEN

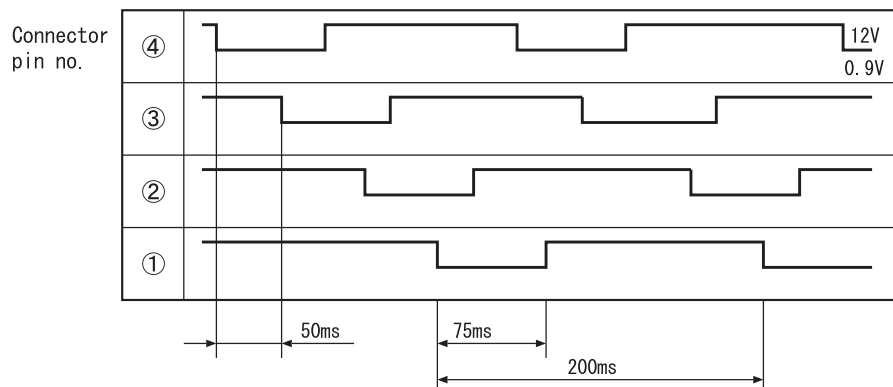

Fig. 6-2

With expansion valve control, opening degree is adjusted to stabilize target temperature by detecting compressor head temperature. The period of control is about once per 20 seconds and output a few pulse.

7. Outdoor DC fan motor control circuit

- This model is built with DC fan motor control circuit inside outdoor electrical unit.

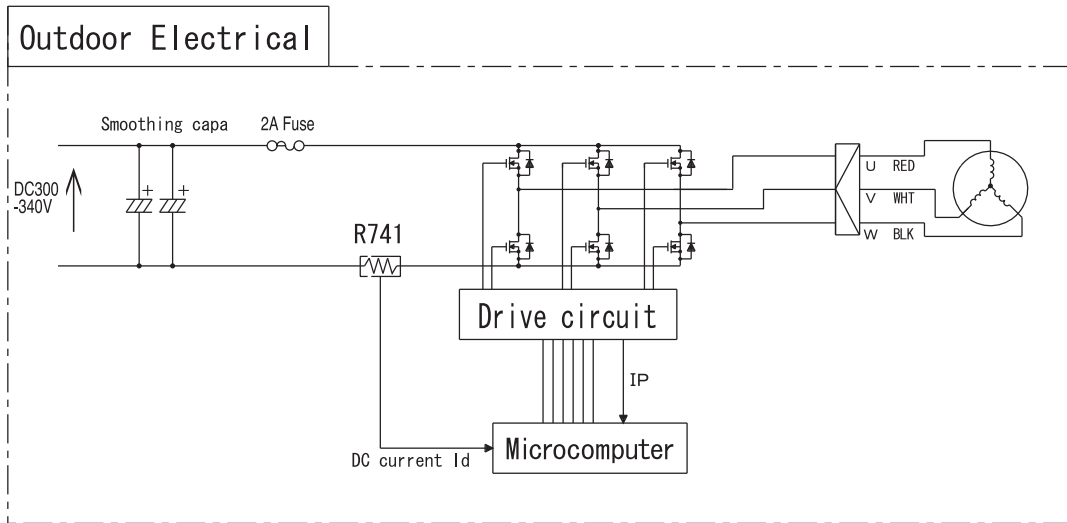

Fig 7-1

This DC fan motor is control by outdoor microcomputer that follow the operating instruction received from indoor microcomputer. The DC current that flow from R741 will presume actual operation speed and control the rotation to follow the operating instruction. Based on this DC current it will detect a over current and other fan motor failure.

(1) Fan motor speed controller during starting

Due to the interference of strong wind etc., operation movement is changed based on fan direction and rotation speed as shown below during starting of operation.

In addition, the fair wind is define as wind that blow to outside direction using Mouth Ring part. At strong and contrary wind ... The rotational speed is not controlled as to protect the equipment and fan will rotate reversely depend on the wind. Automatically start when wind condition become weak.

At contrary wind ... The rotational speed is controlled in fair wind direction after it slowly reduce the speed and finally stop.

At fair wind ... The rotational speed is controlled as it is.

At strong fair wind ... The rotational speed is not controlled as to protect the equipment and fan will rotate reversely depend on the wind. Automatically start when wind condition become weak.

(2) Fan motor speed controller during unit operating

There is a case where fan rpm is reducing during rotating caused by interference of strong wind. If this condition continue in long period, fan will stop rotating. (LD301 : 11 times blinking). The unit will restart according to control as per during start (1).

(3) Method of confirming self diagnosis LD301 lamp : 12 times blinking

If the unit stop and LD301 on the pwb blinking 12 times [fan lock stop is detected], follow below steps to confirm it.

1. Fan lock stop is detected when something has disturb the fan rotation by inserting material into propeller fan or ice has growing inside outdoor unit caused by snow.
Remove it if found something is bloking the fan.
2. Confirmed that CN24 connector is securely inserted. Fan lock stop is detected also when connector is not properly inserted. Please securely insert if found any disconnection.
3. Fan lock stop also can be detected where strong wind blown surrounding the unit.
Please confirm after restart the unit. (It may take few minutes to operate the compressor)
It is not a malfunction of electrical unit or fan motor if the unit run continuesly after restart the unit.
4. Check fan motor condition as below procedure.

[Checking Fan Motor] procedure

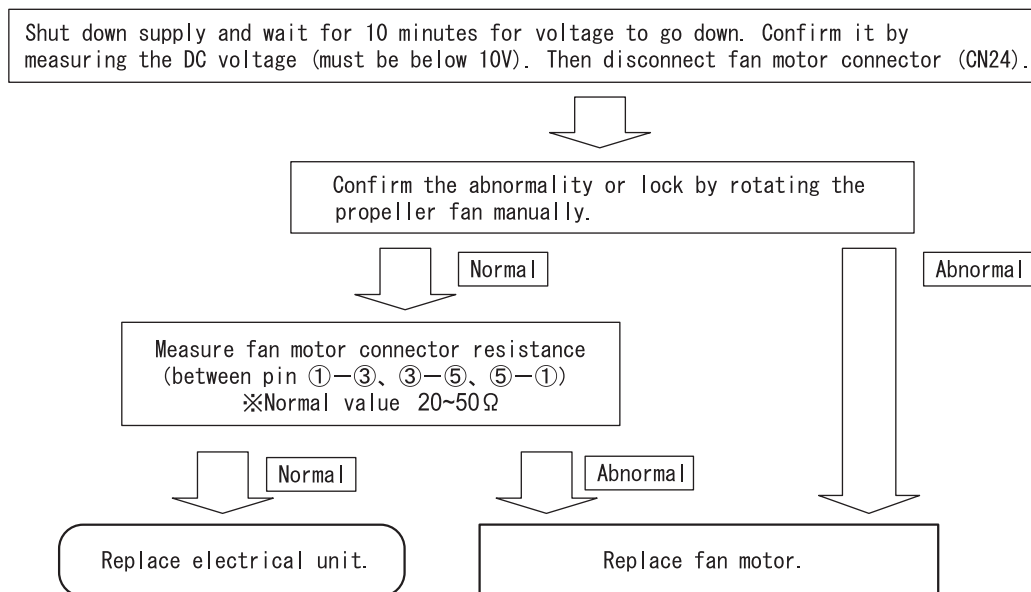

5. Reconnect again fan motor connector (CN24).

※Please confirm above checking procedure if found 2Afuse blown.

If fan motor is broken, replace both electrical unit and fan motor.

Caution

※Beware of electric shock due to high voltage when conducting an operation check.

Power supply for DC fan motor and compressor is common (DC260-360V).

9. Hibernation Mode

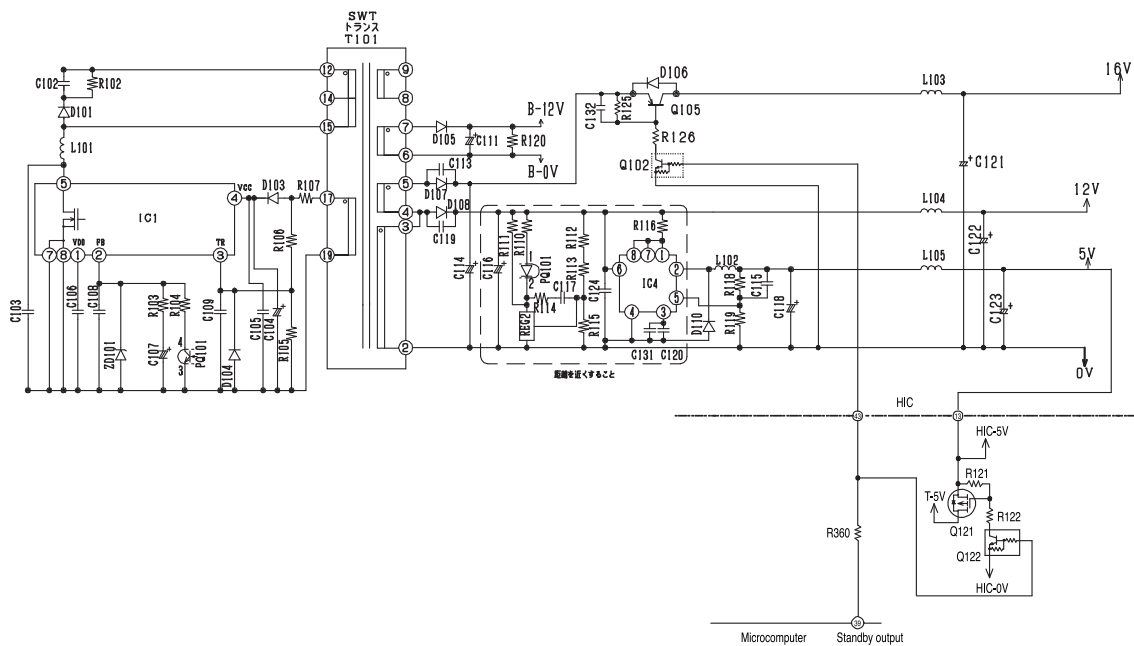

Fig. 9-1

- This model have designed to enter hibernation mode for energy saving and power consumption reduction during stanby.
- Unit will enter hibernation mode during below stanby condition if not received any signal from remote controller and expansion valve already completed initialization .
 - 1) Stanby continuesly
 - 2) Unit in running condition, then off the unit by remote controller and leave the unit in stanby condition.
- During hibernation activation, main microcomputer pin (39) will change to LOW condition. Due to this pin become LOW, Q121 and Q122 will be OFF. As Q121 OFF, T-5V will drop to 0V. Beside, Q102 and Q105 will be OFF and causing 16V also drop to 0V.
- During hibernation mode, DC voltage will be as below condition.
 - (1) B-12V : Maintain at 12V
 - (2) 16V : Drop to 0V
 - (3) 12V : Maintain at 12V
 - (4) 5V : Maintain at 5V
 LD301 on the Main P.W.B will be OFF during this mode.
- If outdoor unit have failure/error, all indication including error diagnosis LED will be OFF once the smoothing capacitor (C019 ~ C021) voltage reduce to 38.7V.
- For inspection during hibernation mode, service person can measure DC voltage B-12V, 12V and 5V on Main P.W.B. But to measure DC voltage 16V on Main P.W.B., service person shall on the indoor unit by remote controller first. This will change the unit from hibernation mode to normal.

Self-diagnosis memory function

The failure modes memorized in the nonvolatile memory of the indoor unit are can be recall by operating the remote controller.

This is effective when checking the failure modes, if you have turned off the power or restarted the operation of the unit without checking the number of blinkings of the indicator in the self-diagnosis indication.

(The failure modes are memorized for latest occurrences of failure only)

Moreover, the failure modes that do not frequently occur and do not lead to self-diagnosis indication of the indoor unit can be also memorized. After all memory is cleared, if the failure modes are retrieved from the memory and rechecked at a later date, it is possible to understand the failure phenomena that could not be recognized when you visited the user.

<How to reindicate the failure modes >

1. Turn off the power .
2. Set the remote control unit to the stop screen.
3. With the "function selector" button on the remote controller ,set the operation mode to "Cooling".
(The characters of "Cooling" is indicated on the LCD.)
4. Turn on the power.
5. Set the temperature to "32°C" with the "Room temperature \wedge " button.
6. Press the "On/Off" button while pressing the "Room temperature \wedge " button.
(The remote controller transmits the signal.)
7. The product beeps to indicate that it has just received the signal and redisplayes the failure mode.

FUNCTION Selector
Use this button to select the operating mode. Every time you press it, the mode will change from (A) (AUTO) to (B) (COOL) to (C) (HEAT) to (D) (DEHUMIDIFY) and to (E) (FAN) cyclically.

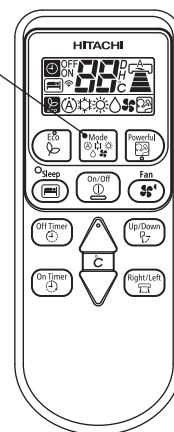

<How to clear the failure mode data >

1. Redisplay the troubleshooting status. (See the above procedure)
2. Turn off the power .
3. With the "function selector" button on the remote controller ,set the operation mode to "Heating".
(The characters of "Heating" is indicated on the LCD.)
4. Turn on the power.
5. Set the temperature to "16°C" with the "Room temperature \vee " button.
6. Press the "On/Off" button while pressing the "Room temperature \vee " button.
(The remote controller transmits the signal)
7. The product beeps to indicate that it has just received the signal. The data has now been cleared.

[Cautions]

- Take note that this function may be disabled when procedures other than the one above are taken.
(If the function is disabled, turn off the power once and follow the procedure again.)
- If nothing is recorded in the memory, the lamp does not blink even if the operation for reindication is performed.
- In order to read 5 different memory of faulty, please use wireless weekly remote (SPX-RCKA2-Optional part).
Please refer method self diagnosis memory function in service manual (RAK-18NHA2,RAK-25NHA2,RAK-35NHA2,RAK-50NHA2).

SERVICE CALL Q & A

COOLING MODE

Q1 The compressor has stopped suddenly during cooling operation.



A1 Check if indoor heat exchanger is frosted. Wait for 3-4 minutes until it is defrosted.

If the air conditioner operates in cooling mode when it is cold, the evaporator may get frosted.

DEHUMIDIFYING MODE

Q1 Sound of running water is heard from indoor unit during dehumidifying.



A1 Normal sound when refrigerant flows in pipe.

Q2 Compressor occasionally does not operate during dehumidifying.



A2 Compressor may not operate when room temperature is 10°C or less. It also stops when the humidity is preset humidity or less.

Q3 Cold air comes out during a dehumidifying operation.



A3 To improve the dehumidification efficiency performs quiet fan operation. Therefore the air is cold and it is not a malfunction.

Q4 The operation does not stop even by setting the temperature higher than room temperature on the remote controller.



A4 It sets to perform dehumidifying operation by setting the temperature slightly lower than remote controller setting.

HEATING MODE

Q1 The circulation stops occasionally during Heating mode.



A1 It occurs during defrosting. Wait for 5 -10 minutes until the condenser is defrosted.

Q2 The product begins with a weak wind during heating even though set to "HI" or "MEDIUM"



A2 At the beginning of heating, the fan speed will run at weak wind about 30 seconds, after that the wind will then increase to be required fan speed.

Q3 Heating operation stops while the temperature is preset at "30".



A3 If temperature is high in the outdoor, heating operation may stop to protect internal devices.

AUTO FRESH DEFROSTING

Q1 After the ON/OFF button is pressed to stop heating, the outdoor unit is still working with the OPERATION lamp blinking.



A1 Auto Fresh Defrosting is carried out : the system checks the outdoor heat exchanger and defrosts it as necessary before stopping operation.

AUTO OPERATION

Q1 How is the automatic operation mode determined?



A1 According to the room temperature heating or cooling operation is automatically selected. Refer to the basic operation section.

Q2 Can I set the room temperature at automatic operation.



A2 The room temperature setting can be set between 16°C - 32°C.

NICE TEMPERATURE RESERVATION

Q1 When on-timer has been programmed, operation starts before the preset time has been reached.



A1 This is because "Nice temperature reservation"function is operating. This function start operation earlier so the preset temperature is reached at the preset time. Operation may start maximum 60 minutes before the preset time.

Q2 Does "Nice temperature reservation" function operate during dehumidifying?



A2 It does not work. It works only during cooling and heating.

Q3 Even if the same time is preset, the operation start time varies.



A3 This is because "Nice temperature reservation"function is operating. The start time varies according to the load of room. Since load varies greatly during heating, the operation start time is corrected, so it will vary each day.

AT STARTING OPERATION

Q1 When only the power switch is turned on, the deflector at the air outlet moves even if the START/STOP button is not pressed.



A1 To ensure correct opening and closing of the deflector, the deflector will move when power is turned on or the unit is to be operated in order to check its fully opened and closed positions.

Q2 When the heating operation is started, the indoor fan does not start immediately and the deflector at the air outlet occasionally does not fully open.



A2 This is because the preheating device is working. It will not start to drive the fan until the refrigerating cycle warms up and warm air blows. Wait for a while. The deflector does not open either during preheating or for one minute after preheating is finished.

Q3 When the unit built behind the gallery (lattice door) is to be started immediately after it has stopped, the unit occasionally will not start.



A3 Such a phenomenon may occur with built-in installation where heat is likely to be stuffy. Install the unit as near to the lattice door as possible so that air is not short-circuited, or provide a partition between the unit and lattice door.

OTHERS

Q1 The indoor fan varies among high air flow, low air flow and breeze in the auto fan speed mode. (Heating operation)



A1 This is because the cool wind prevention function is operating, and does not indicate a fault.

The heat exchanger temperature is sensed in the auto fan speed mode. When the temperature is low, the fan speed varies among high air flow, low air flow and breeze.

Q2 Loud noise from the outdoor unit is heard when operation is started.



A2 When operation is started, the compressor rotation speed goes to maximum to increase the heating or cooling capability, so noise becomes slightly louder. This does not indicate a fault.

Q3 Noise from the outdoor unit occasionally changes.



A3 The compressor rotation speed changes according to the difference between the thermostat set temperature and room temperature. This does not indicate a fault.

Q4 There is a difference between the set temperature and room temperature.



A4 There may be a difference between the set temperature and room temperature because of construction of room, air current, etc. Set the temperature at a comfortable level for the space.

Q5 Air does not flow immediately after operation is started.



A5 Preliminary operation is performed for one minute when the power switch is turned on and heating or dehumidifying is set. The operation lamp blinks during this time for heating. This does not indicate a fault.

Q6 Mold in the room cannot be inhibited even after performing the air conditioner drying operation.



A6 Air conditioner drying operation is to dry the interior of the indoor unit to inhibit the growth of mold. It is not to inhibit the mold growth in the room.

Q7 The interior of the indoor unit seems to be still damp even after performing the air conditioner drying operation.



A7 Condition of the interior of the indoor unit varies depending on usage of the unit and condition of the indoor unit. If it is not dried after the first try, perform the drying more than one time for better effect.

Inspection instructions



Warning

Note that the 0 V line of the outdoor electrical parts and the primary power circuit of the indoor electrical parts have voltages to ground as illustrated in the right-hand figure.

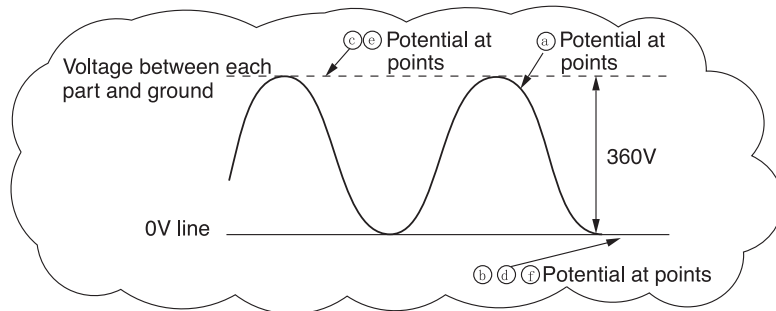
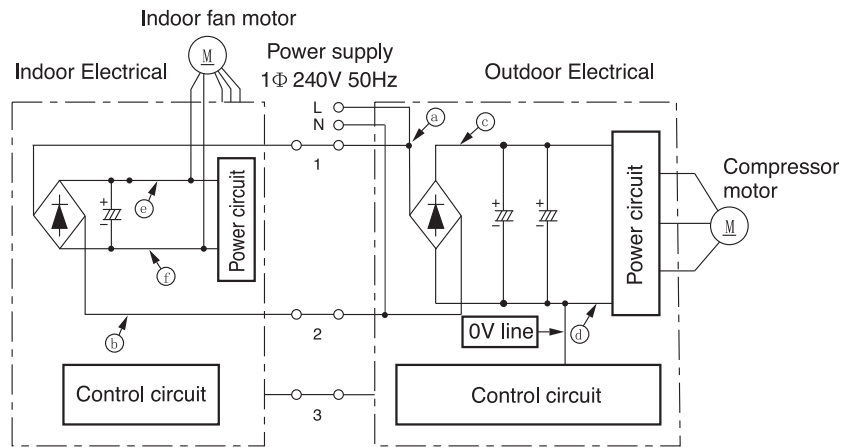

Warning

When conducting a check with an oscilloscope or something similar, do not ground the oscilloscope. Note that the oscilloscope will be subjected to voltages as illustrated in the figure above.

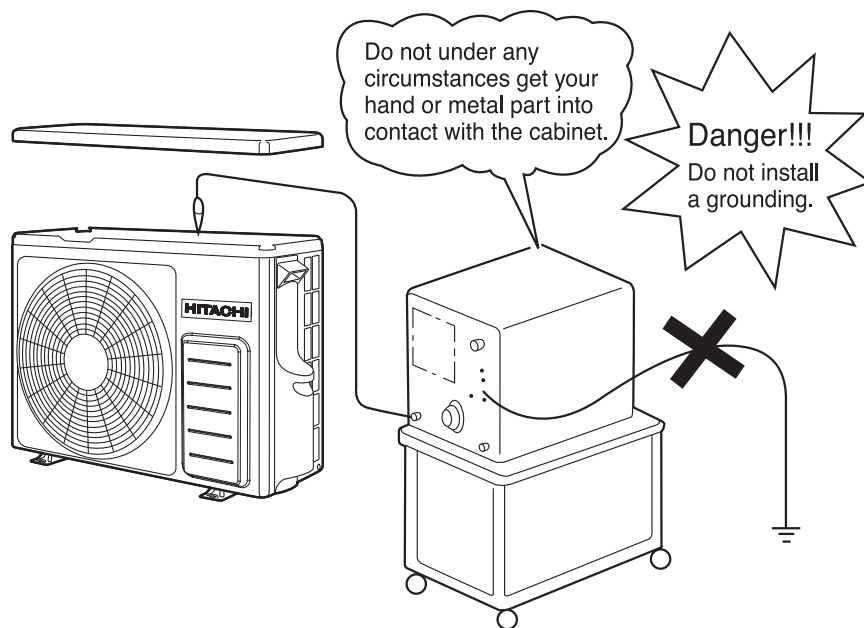

DISCHARGE, PROCEDURE AND POWER SHUT OFF METHOD FOR POWER CIRCUIT



WARNING



Caution

- Voltage of about 360 V is charged between the terminal of smoothing capacitors ($500\mu\text{F} \times 3$).
- During continuity check for each circuit part of the outdoor unit, be sure to discharge the smoothing capacitors.

Discharge Procedure

1. Turn off the power.
2. After power is turned off, wait for 10 minutes or more .Then, remove electrical parts cover and apply soldering iron of 30 to 75 W for 15 seconds or more to TAB7 and TAB8 terminals on the main P.W.B. as shown in the figure below, in order to discharge voltage in smoothing capacitor.

Do not use a soldering iron with transformer: Otherwise, thermal fuse inside transformer will be blown.

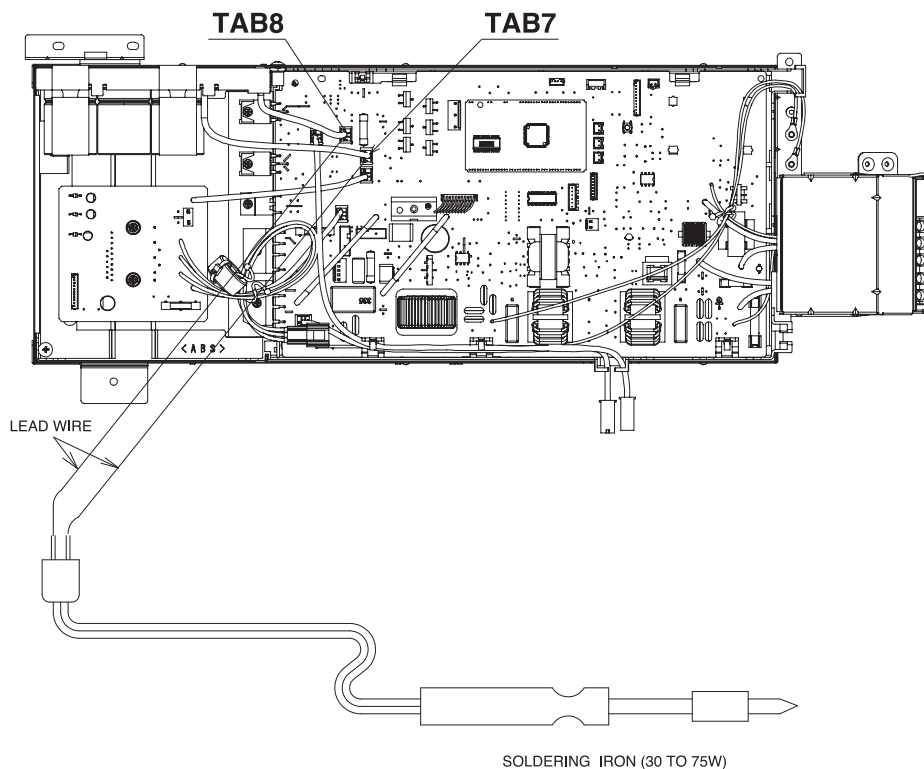

STRUCTURE OF AN INDOOR UNIT ELECTRIC PARTS

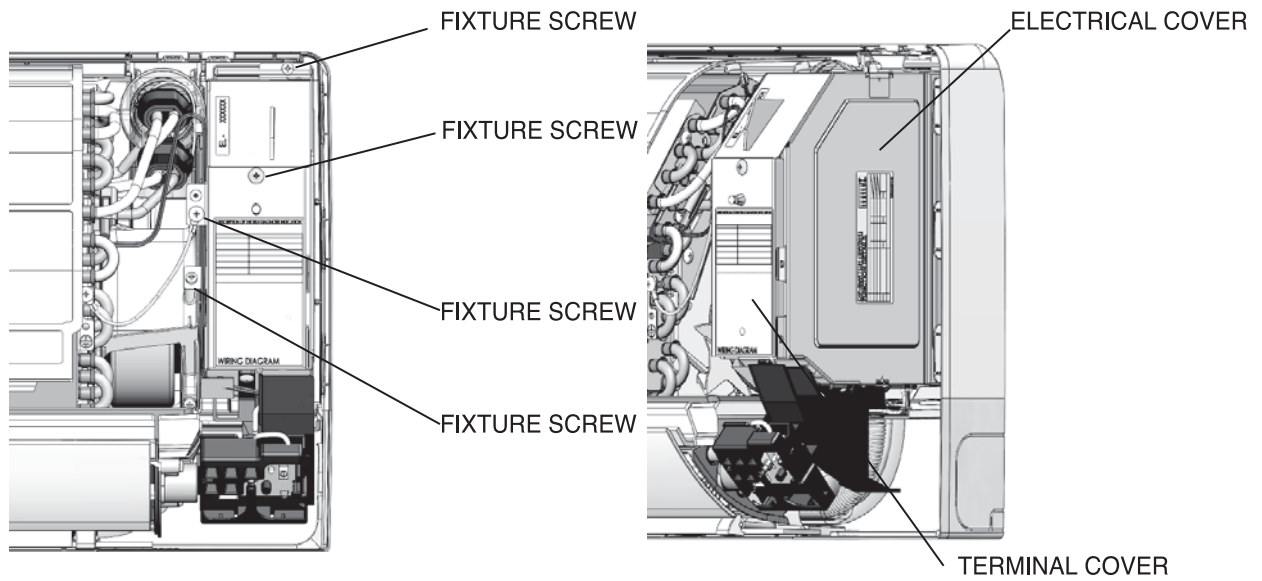

Removing electrical parts

1. Remove the electrical parts cover.
2. Remove the connectors from the CN4 (heat exchange thermistor), CN12 (Vertical sweep motor) and CN16 (fan motor), CN14 (horizontal sweep motor).
3. Remove four lock screws.

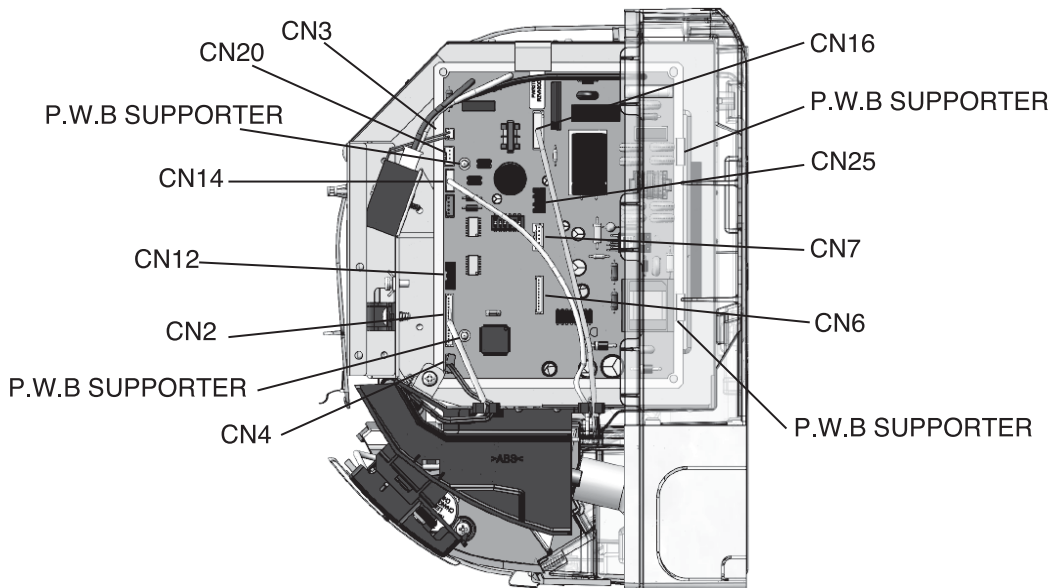

Removing control P.W.B.

1. Remove the connectors from the CN3.
2. Remove the P.W.B. from the P.W.B. support.

Remove the indicating P.W.B.

1. Remove the connector from the CN2 on the control P.W.B.
2. Remove the upper hook from the indicating P.W.B. lock resin, pull the P.W.B. forward a little and remove it.

Other instructions

(1) Detaching and reattaching the receptacles for tab terminal

All the receptacles for connecting tab terminals are with a locking mechanism. Forcibly pulling any such receptacle without unlocking it will destroy it. Be on guard.

When reconnecting it, insert it securely all the way home.

· Receptacle types and how to unlock them

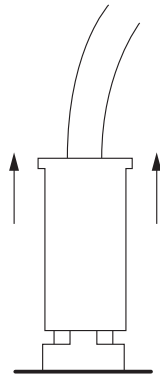

Vertical (with a resin case)

Hold the resin case and pull it out.

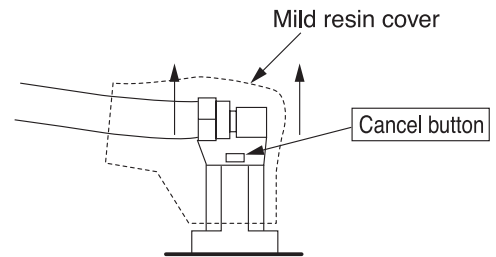

Horizontal (with a mild resin cover)

Hold the cancel button down on the mild resin cover while pulling it out.

(2) Detaching and reattaching the board connector

The product comes equipped with many board connectors provided with lock mechanism. Forcibly pulling any such part without unlocking it will destroy it. Be on guard. When reconnecting it, insert it securely all the way home.

Pinch the locking mechanism with your fingers and pull it out unlocked.

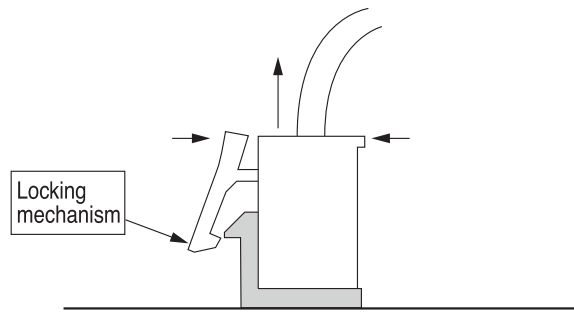

(3) Do not detach or reattach the connectors while energized

Do not under any circumstances detach or reattach the connectors while energized. That would destroy the board components and fan motor. For both the indoor and outdoor boards, ensure that the smoothing capacitor has discharged its electricity fully before you do your work.

Troubleshooting support

No	Function	Description
1	Self-diagnosis display [Display on the indoor unit side]	<ul style="list-style-type: none"> · The failure mode detected on the indoor unit side is displayed by blinking the "timer lamp". And a failure detected on the outdoor unit side will be indicated by the "time lamp" blinking 4 times. · If the outdoor unit side detects a failure, the product will first conduct several operation retrials. <p>There are some failure modes with no lamp display while retrials are continued.</p> <p>[Failure mode where retrials are continued and the indoor unit lamp does not end up giving a display]</p> <ul style="list-style-type: none"> OH thermistor heat-up Overload lower limit cut Low-frequency things
	[Display on the outdoor unit side]	<ul style="list-style-type: none"> · The failure mode detected on the outdoor unit side is displayed by blinking the "LD301". Detecting a failure will stop the outdoor unit and keep blinking the LD301 until it is restarted. <p>(The communication error will persist until the communication is reestablished.)</p>
2	Self-diagnosis memory	<ul style="list-style-type: none"> · The failure modes detected on the indoor and outdoor unit sides are stored in the nonvolatile memory of the indoor unit and can be read later on. <p>(The memory will remain even after power-off.)</p> <ul style="list-style-type: none"> · The failure modes detected on the outdoor unit side are written in memory every time any such mode occurs. The failure mode can therefore be detected on the indoor unit side without waiting for the retry frequency to reach the display of the indoor unit lamp. Moreover, the normal self-diagnosis display function which rarely occurs will store and display failure modes that do not end up displaying the indoor unit lamp. <p>(Any such mode may be unable to be stored if indoor or outdoor communications is in a failure.)</p> <ul style="list-style-type: none"> · The product stores 5 last-stored failure modes. · There is a function for deleting memory. Once you clear the memory and run the product for several days, you can read the failure modes and check them, thereby detecting the less frequent failure phenomena. · Failure modes can be checked by both the blinking of the lamp of the indoor unit and the display of the remote control liquid crystal display.

※The "self-diagnosis function of the communication circuit" available in our conventional models is now incorporated as part of the normal self-diagnosis function. In the case of a failure in the communication circuit, you do not have to conduct a special operation and the operations can be automatically divided into 3 blinking operations and 12 blinking operations of the timer lamp. However, a strong external noise may have resulted in 12 times of blinking.

SELF-DIAGNOSIS DISPLAY MODE (INDOOR SIDE)

While the "timer lamp" (orange), of the indoor unit is blinking, troubleshoot the product while referring to the table below.

- How to count the lamp blinking frequency
 - The product will repeat blinking with 2-second intermissions.
 - The blinking speed is as follows: on for 0.35 seconds and off for 0.35 seconds.

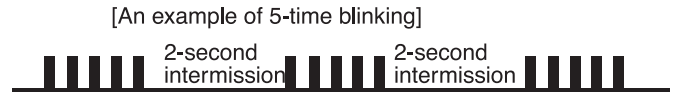

- If you wish to try another operation while the lamp is blinking, operate the START/STOP button on the remote control unit twice. The first push will reset the indoor microcomputer, while the second will activate the product

Refer to the table below if the timer indicator (orange) is blinking.

LAMP BLINKING MODE	MAIN DEFECTIVE
ONCE	REFRIGERANT CYCLE DEFECTIVE
2 TIMES	FORCED OPERATION OF OUTDOOR UNIT
3 TIMES	INDOOR INTERFACE CIRCUIT
4 TIMES	OUTDOOR ELECTRICAL ASSEMBLY DEFECT
9 TIMES	ROOM OR HEAT EXCHANGER THERMISTOR DEFECT
10 TIMES	OVERCURRENT IN DC FAN MOTOR
12 TIMES	OUTDOOR INTERFACE CIRCUIT
13 TIMES	IC531 DEFECT
(- LIGHT FOR 0.35 SEC AT INTERVAL OF 0.35 SEC)	

- * IF THE INTERFACE CIRCUIT IS DEFECTIVE WHEN THE POWER IS TURNED ON. THE SELF-DIAGNOSIS INDICATION WILL NOT WORK.
- * IF THE INDOOR UNIT CAN NOT BE OPERATED AT ALL.

REFER TO THE BELOW TABLE IF THE INDOOR UNIT DOSE NOT WORK AT ALL.



FIX CN2 CONNECTOR	ACTION /REPLACEMENT PARTS, etc
FU1 (3.15A) FUSE BLOWN	REPLACE THE PART WHICH CAUSED BLOWING/DISCONNECTION OF FU1(3.15A) FUSE
COME OFF OR DISCONNECTION OF THE CONNECTOR FOR INDICATING P.W.B	FIX CN2 CONNECTOR
FAILURE OF CONTROL P.W.B	REFER TO THE SERVICE GUIDE FOR HOW TO DETERMINE THE FAILED PART





SELF-DIAGNOSIS MEMORY FUNCTION



Failure modes are stored in the nonvolatile memory of indoor unit and shall be redisplayed by remote controller.

This function is useful in checking the failure modes either during switching OFF the power or restarting the device without checking the number of indication lamp blinking. Remote controller can redisplay up to last 5 failure modes from the memory. However, failure modes which are rarely to occur are also stored in the memory which caused the numbers of failure more than 5. Thus, for some failure modes which are unable to retrieve because of remote controller limit to redisplay only 5 failure modes, it can be found by clearing up the memory first then recheck the memory content again during the visit at the customer place.



< How to redisplay failure diagnosis >

1. Turn the circuit breaker OFF.
2. Set the remote controller to OFF condition, indicated by **OFF** on the display.
3. By pressing  (MODE) button on the remote controller, set to Cooling operation indicated by  (COOL).
4. Turn the circuit breaker ON.
5. Set the room temperature setting on the remote controller to 32°C by pressing the (TEMP \downarrow or \uparrow) button.
6. Set the fan speed with the  (FAN SPEED) button according to the desired failure information. (Refer to the corresponding table below)

Fan Speed	Data
AUTO 	Newest
HI 	Second newest
MED 	Third newest
LOW 	Fourth newest
SILENT 	Oldest

7. While directing the remote controller towards the receiver of the indoor unit, press (TEMP \uparrow) button and  (START/STOP) button simultaneously. (The remote controller perform signal transmission with the device.)
8. The device beeps [Pi-] to indicate that it has just received the signal to redisplay the failure mode.
9. Direct the remote controller towards the receiver of indoor unit (within 2 meters in front of indoor unit) and press the  (INFO) button. Wait for 2 seconds for signal transmission. An error code will be displayed on the remote controller display.

< How to clear the troubleshooting data >

1. Redisplay the troubleshooting status. (See the above procedure.)
2. Turn the circuit breaker OFF.
3. By pressing  (MODE) button on the remote controller, set to Heating operation indicated by  (HEAT).
4. Turn the circuit breaker ON.
5. Set the room temperature setting on the remote controller to 16°C by pressing the (TEMP \downarrow or \uparrow) button.
6. While directing the remote controller towards the receiver of the indoor unit, press (TEMP \downarrow) button and  (START/STOP) button simultaneously. (The remote controller perform signal transmission with the device.)
7. The product beeps for a second [Pi-] to indicate that it has just received the signal. The data has now been cleared.

< How to display error code in case of failure just occurs >

If timer lamp  of the indoor unit blinking and operation stops, please perform below procedures.

1. Direct the remote controller towards the receiver of indoor unit (within 2m in front of the indoor unit) and press  (INFO) button.
2. Wait for 2 seconds for signal transmission.
3. Indication of error code will be shown on the remote controller display for 10 seconds.

For example :

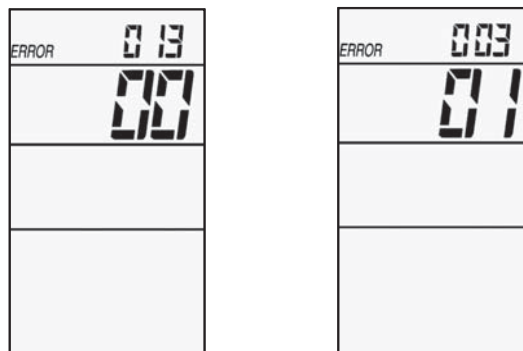

For details information regarding error code, please refer to page 69 .

For detail information regarding error code, please refer to following table.

	TIMER LAMP BLINKING	LD301 BLINKING	CODE	MEANING	DETAILS	MAIN CHECK POINT
INDOOR	1 time	-	001 00	Refrigerant cycle fault	When the indoor heat exchanger temperature is too much low in the heating mode or too much high in the cooling mode.	1. Reversing valve defective 2) Heat exchanger thermistor disconnect (only heating mode) 3) The thermal fuse(102 \square) defective
	2 times	-	-	Outdoor unit is under forced operation.	It is not failure	-
	3 times	9 times (sigle only)	003 00	Communication error between indoor and outdoor units.	Indoor interface circuit broken	1. Indoor interface circuit
	9 times	-	009 00	Indoor thermistor fault	Room thermistor or Heat exchanger thermistor is open circuit or short circuit.	1. Room thermistor 2. Heat exchanger thermistor
	10 times	-	010 00	Abnormal rotating numbers of DC fan motor	Over current is detected at the DC fan motor of the indoor circuit	1. Check CN2, and insert properly 2. Check the fan motor, is it mechanically locked? 3. Fan motor PCB damage
	12 times	9 times	012 00	communication error between indoor and outdoor units	Outdoor interface circuit broken	1. Outdoor interface circuit
	13 times	-	013 00	PROM (IC531) or Micon damage	Data reading error of PROM (IC531)	1. IC531 or Micon
OUTDOOR	4 times	2 times	002 01	Peak current cut	Over current is detected.	1.Compressor 2. P.W.B.s
	4 times	3 times	003 01	Compressor abnormal low speed rotation	Position detection signal is not input during operation.	1.P.W.B.s 2.Compressor
	4 times	4 times	004 01	Compressor switching failure	Fail to switch from initial low frequency sync to position detection sync.	1. P.W.B.s 2.Compressor
	-	5 times	005 01	Overload lower limit cut	Overload condition still persisting even when rotation speed is below the lower rpm limit.	1. Outdoor unit is exposed to direct sunlight or its air flow blocked. 2. Fan motor 3. Fan motor circuit 4. The voltage is extremely low.
	-	6 times	006 01	OH thermistor temperature rise	OH thermistor is operating.	1. Leak of refrigerant 2. Compressor 3. OH thermistor circuit 4. Fan motor 5. Fan motor circuit
	4 times	7 times	007 01	Abnormal outdoor thermistor	Thermistor is opened or shorted.	1. Thermistor 2. Connection of thermistor is faulty 3. Thermistor circuit
	12 times	9 times	009 01	Communication error	When indoor unit is not connected, it blinks similarly, not malfunction.	1. Cable is wrong connection 2. Cable is open 3. Interface Circuit of Outdoor main P.W.B 4. Interface Circuit Indoor main P.W.B
	-	10 times	010 01	Abnormal power source	Power supply voltage is incorrect.	1. Power supply voltage 2. Receptacle of wire for P.W.B.IPM is not properly inserted
	-	11 times	011 01	Fan stop for strong wind	Fan motor load is too heavy or rotation disturbed by wind blow.	1. Fan motor 2. Outdoor condition (wind)
	4 times	12 times	012 01	Fan motor fault	Outdoor fan rpm is not rotate as intended rpm.	1. Fan motor 2. Fan motor circuit
	4 times	13 times	013 01	EEPROM reading error	Microcomputer cannot read the data in EEPROM.	1. P.W.B main
	4 times	14 times	014 01	Active converter defective	Over voltage is detected, compressor abnormal load.	1. P.W.B.s 2. Compressor
	4 times	15 times	015 01	Abnormal PWB circuit	Active circuit abnormal.	1. P.W.B.s
-	16 times	016 01	Software peak current cut			

< Cautions >

This function is effective only once immediately after the power is turned on. It will not work if you have performed another remote control operation beforehand. Note also that it may not function in response to a procedure other than the above. (If it does not work, turn off the power, turn it back on and repeat the procedure.)

If the memory stores nothing, performing a redisplay operation will not blink the lamp.

For a normal operation, turn off the power and turn it back on. After the above operation, the product will not receive a remote control signal normally.

After clearing the troubleshooting data, turn off the power. (If you do not turn off the power, the product will become unresponsive to remote control signals.)

SELF-DIAGNOSIS LIGHTING MODE

MODEL RAC-70NPD



DANGER (DC 360V)

● SWITCH OFF MAIN POWER SUPPLY ● DO NOT TOUCH ANY OTHER PARTS EXCEPT TEST (SERVICE) TO THE OUTDOOR UNIT AT LEAST 10 MINUTES BEFORE START THE SERVICING WORK

● MAKE SURE THE LEVEL DC VOLTAGE BETWEEN TAB7/AVHT(+) AND TAB8/BLK(-) IS LESS THAN 10V

SELF DIAGNOSIS LIGHTING MODE
 LIT BLINKING OFF

SELF-DIAGNOSIS NAME	MAIN CHECK POINT	HOW TO REPAIR
LD301 (RED)		
[1] DURING OPERATION		
NORMAL OPERATION	COMPRESSOR OPERATION	NOT MALFUNCTION
OVERLOAD OPERATION	COMPRESSOR OPERATION	THIS SHOW AN OVERLOAD, NOT MALFUNCTION

● BLINKING DURING OVERLOAD 0.3SEC ■■■■ (■■■■ LIGHTS FOR 2 SEC. AT INTERVAL OF 0.3 SEC.)

[2] DURING STOP

SELF-DIAGNOSIS NAME	MAIN CHECK POINT	HOW TO REPAIR
NORMAL STOP IS STOPPED BY INDOOR THERMOSTAT OR MAIN OPERATION OFF	1. NO NEED TO CHECK	1. NOT ANY MALFUNCTION
FAN MODE OPERATION/RESET STOP	1. WAITING FOR COMPRESSOR START 2. OTHER THAN ABOVE	1. NORMAL
PEAK CURRENT CUT	1. P.W.B.s DEFECTIVE 2. COMPRESSOR ABNORMAL LOAD	1. CHANGE THE P.W.B.s 2. CHECK THE COMPRESSOR
ABNORMAL LOW-SPEED ROTATION	1. P.W.B.s DEFECTIVE 2. COMPRESSOR ABNORMAL LOAD	1. CHANGE THE P.W.B.s 2. CHECK THE COMPRESSOR
SWITCHING FAILURE	1. COMPRESSOR OPEN 2. COMPRESSOR ABNORMAL LOAD 3. P.W.B.s DEFECTIVE	1. INSERT THE CONNECTOR 2. CHECK THE COMPRESSOR 3. CHANGE THE P.W.B.s

BLINKING(TIMES)	SYMBOL	REASON	REPAIR METHOD
5 TIMES	■■■■■	OVERLOAD/LOWER LIMIT CUT	1. REMOVE THE OBSTRUCTION OF THE OUTDOOR UNIT 2. CHECK CYCLE PIPE
6 TIMES	■■■■■	OH THERMISTOR TEMPERATURE RISE	1. DUE TO CONNECTOR OPEN 2. CHECK THE CYCLE PIPE AND RECHARGE THE REFRIGERANT 3. CHANGE THE P.W.B.s
7 TIMES	■■■■■	THERMISTOR ABNORMAL	1. INSERT PROPERLY 2. CHANGE THE THERMISTOR 3. CHANGE THE P.W.B.s
9 TIMES	■■■■■	COMMUNICATIONS ERROR	1. CONNECT CONNECTING CABLE PROPERLY 2. CHANGE THE CONNECTING CABLE 3. CHANGE THE P.W.B.s
10 TIMES	■■■■■	ABNORMAL POWER SOURCE	1. REACTOR IS UNCONNECTED 2. ABNORMAL AC INPUT: OUT OF RANGE (230±10%) 3. AC INPUT IS NORMAL
11 TIMES	■■■■■	OUTDOOR FAN STOP BY STRONG REVERSE WIND	1. IT WILL RE-START AFTER WIND BECOME WEAK 2. REMOVE THE OBSTRUCTION OF THE FAN MOTOR 3. CHANGE THE P.W.B.s
12 TIMES	■■■■■	OUTDOOR FAN LOCK ERROR	1. IT WILL RE-START AFTER WIND BECOME WEAK 2. REMOVE THE OBSTRUCTION OF THE FAN MOTOR 3. CHANGE THE P.W.B.s
13 TIMES	■■■■■	EEPROM READING ERROR	CHANGE THE P.W.B.s
14 TIMES	■■■■■	ACTIVE VOLTAGE ABNORMAL	1. CHANGE THE P.W.B.s 2. CHECK THE COMPRESSOR COMPRESSOR LOAD
15 TIMES	■■■■■	CIRCUIT ABNORMAL	CHANGE THE P.W.B.s
16 TIMES	■■■■■	HIGH LOAD STOP	1. SERVICE VALVE CLOSE 2. OBSTACLE SURROUND THE OUTDOOR UNIT 3. CHECK FILTER IN INDOOR UNIT
EXAMPLE OF BLINKING (G.TIMES)	■■■■■	2SEC ■■■■■	(■■■■■ LIGHTS FOR 0.25 SEC. AT INTERVAL OF 0.25 SEC.)

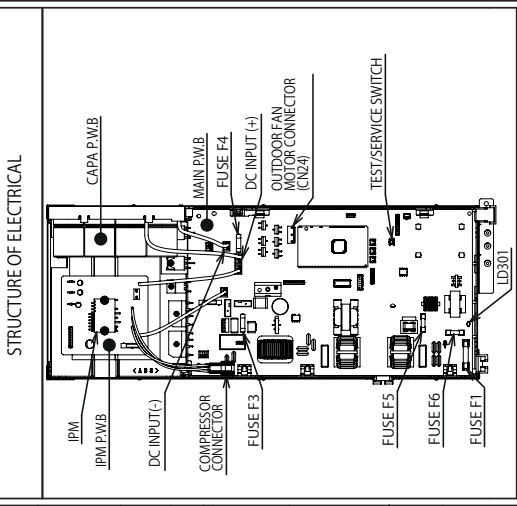

WHEN SELF DIAGNOSIS BLINKS 2,3,4 AND 5 TIMES HAPPEN TO DETERMINE WHETHER COMPRESSOR OR ELECTRICAL UNIT FAULTY, BELOW DIAGNOSIS CAN BE FOLLOWED.

- SELF-DIAGNOSIS METHOD
- SWITCH OFF MAIN POWER SUPPLY.
 - CONNECT THE CONNECTION OF INDOOR/OUTDOOR TERMINAL 3
 - SWITCH ON MAIN POWER SUPPLY
 - WAIT FOR MORE THAN 30 SEC. UNTIL OUTDOOR LD301 BLINKING 9 TIMES.
 - KEEP PRESSING THE TEST SWITCH AT OUTDOOR FOR MORE THAN 5 SEC. UNTIL LD301 FAST BLINKS AND THEN RELEASE THE TEST SWITCH.
 - SELF-CHECK RESULT WILL DISPLAY AT LD301. REFER TO TABLE 2 FOR THE DETAIL OF THE DIAGNOSIS RESULT.
 - SWITCH OFF MAIN POWER SUPPLY ONCE DONE.

TABLE 2 : DURING SELF-DIAGNOSIS COMPLETED

SELF-DIAGNOSIS LIGHTING MODE	REPAIR METHOD
LD301 (RED)	BLINKING
1 TIME	ELECTRICAL OK
2 TIMES	PEAK CURRENT CUT OFF
7 TIMES	COMPRESSOR CURRENT ABNORMAL
10 TIMES	DC VOLTAGE ABNORMAL
13 TIMES	EEPROM READING ERROR

TABLE 3 : OUTDOOR FAN MOTOR INSPECTION (SELF-DIAGNOSIS)

1. SWITCH OFF MAIN POWER SUPPLY.	
2. DISCONNECT OUTDOOR FAN MOTOR CONNECTOR FROM CONNECTOR CN24 OF P.W.B MAIN.	
3. ROTATE THE OUTDOOR FAN SHAFT TO CONFIRM THE FAN MOTOR MOVEMENT EITHER NORMAL OR ABNORMAL.	
4. CHECK THE RESISTANCE VALUE BETWEEN PIN TERMINAL SHOULD BE WITHIN 20 TO 50 Ohm.	
* CONNECT BACK THE OUTDOOR FAN CONNECTOR ONCE FINISH DO INSPECTION.	

- OTHER INSPECTION:
- DIAGNOSIS FOR REVERSING VALVE OPERATION ERROR.
 - CHECK REVERSING VALVE WIRE CONNECTION EITHER WIRE BROKEN OR NOT. IF OK, CHECK FUSE F3. IF BROKEN, REPLACE FUSE OR P.W.B.s.
 - DIAGNOSIS FOR COMMUNICATION SIGNAL ERROR OR OUTDOOR NOT FUNCTIONAL.
 - CHECK WIRING CONNECTION BETWEEN INDOOR AND OUTDOOR.

Diagnosis and troubleshooting of indoor electric parts, outdoor electric parts and refrigerating cycle

Initiating troubleshooting

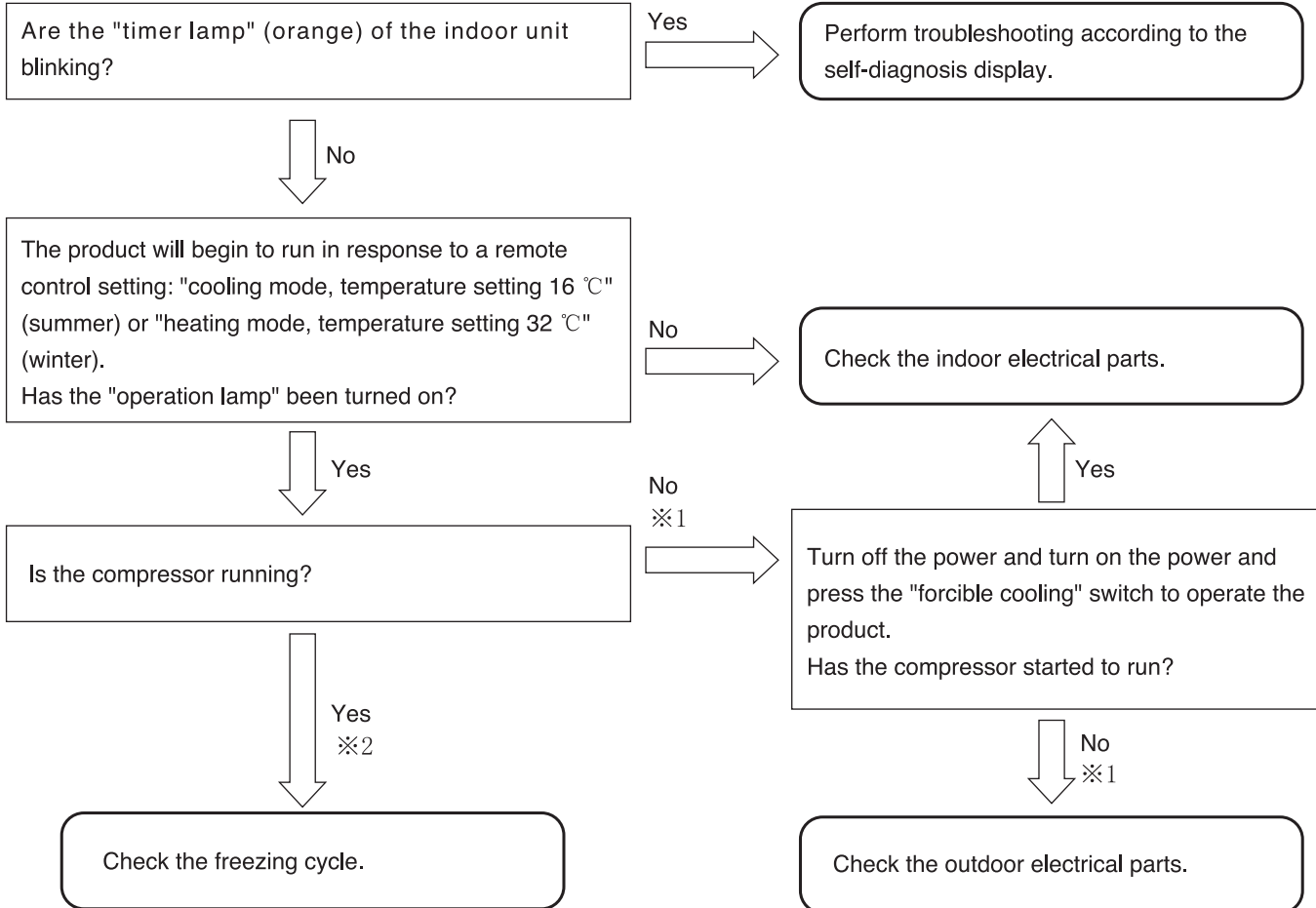

< Troubleshooting by using the self-diagnosis memory function >

- By using the self-diagnosis memory function, you can check the failure mode (※1) occurring in the outdoor electrical parts on the indoor unit side.

- Steps
1. Clear the troubleshooting data.
 2. Run the product for several minutes under the conditions where the compressor runs.
 3. Redisplay and check the data written in the self-diagnosis memory.

- The self-diagnosis memory function can also be used to catch failure phenomena.

- Steps
1. Clear the troubleshooting data.
 2. Have the user use the product as usual until a failure phenomenon occurs.
(The period depends on the incidence of the phenomenon.)
 3. At a later date, redisplay and check the data written in the self-diagnosis memory.

- For the outdoor self-diagnosis display (OH thermistor heat-up, overload lower limit cut) stemming from the freezing cycle or operating condition, the time lag is long from operation startup to the emergence of the phenomenon. Moreover, it is affected by the temperature, sunshine, operating hours, and other factors of the day, so that the phenomenon may not be able to be identified at the time of a repair service visit. In that case too, use the self-diagnosis memory function (※2).
- The outdoor self-diagnosis display "overload lower limit cut" and "OH thermistor heat-up" can be identified only when you are using the self-diagnosis lamp of the outdoor unit and the self-diagnosis memory function of the indoor unit. Note that this will not be automatically displayed on the indoor unit side.

Checking the indoor unit electrical parts

Introduction

First check the failure phenomenon and status, and then move on to elaborate diagnosis.

Initiating troubleshooting

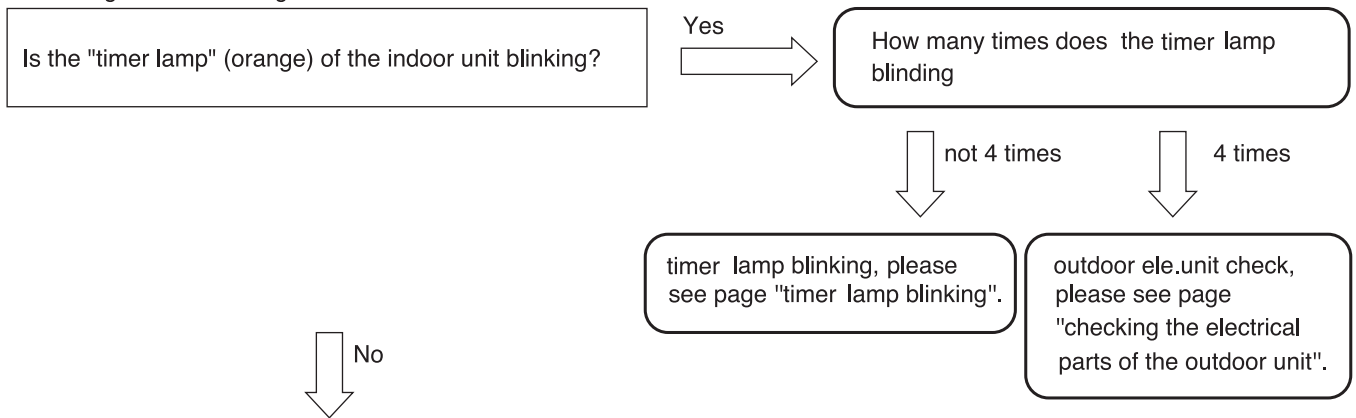

Turn off the power, wait at least 5 seconds, turn it back on, and observe the way the horizontal vanes move for about 30 seconds.

Check 1: Have the horizontal vanes moved? (Yes/No)



Set the remote control unit to cooling mode, temperature setting 16°C (summer), heating mode, temperature setting 32°C (winter) and operate the product.

Check 2: Has the product received the remote control signal and has the "operation lamp" gone on? (Yes/No)

If you responded "Yes" to Check 2:

Check 3: Is the compressor of the outdoor unit running? (Yes/No)

If you responded "No" to Check 2:

Check 4: Does the "emergency operation switch" work? (Yes/No)

Check results and next check items

Check 1	Check 2	Check 3	Check 4	Next check item
No	No	—	No	Go on to "The power will not become turned on".
Yes	No	—	Yes	Go on to "The product will not receive the remote control signal".
Yes	Yes	No	—	Go on to "The compressor will not run".

1. Failure phenomenon: The power will not become turned on.

[Situation] Neither initialization, remote control, nor any other step works on the vane position at power-on.

<p>[Estimated failure locations]</p> <ul style="list-style-type: none"> · 3.15 A fuse blown out · Control power circuit · Connector loose, wire break 	<p>Estimated cause of fuse blowout</p> <ul style="list-style-type: none"> · Abnormally high voltage applied to the power supply · Indoor fan motor out of order · Power circuit out of order
--	---

- [Cautions]
- Before work, check the power supply voltage. An abnormal voltage may be being supplied in some rare occasions due to a defect in the indoor wiring (a wire break in the neutral wire of the single-phase 3-wire power supply).
 - If the 3.15 A fuse has blown out, eliminate the cause of the fuse blowout. Otherwise, there will occur another fuse blowout.
 - If the 3.15 A fuse has blown out due to an abnormally high voltage to the power supply, the varistor (VA001) will deteriorate and become destroyed as well.
 - On a repair service visit due to the failure phenomenon of "The power will not become turned on", take a "3.15 A fuse" and a "varistor" with you.

[Diagnosis flow]

Initiating troubleshooting

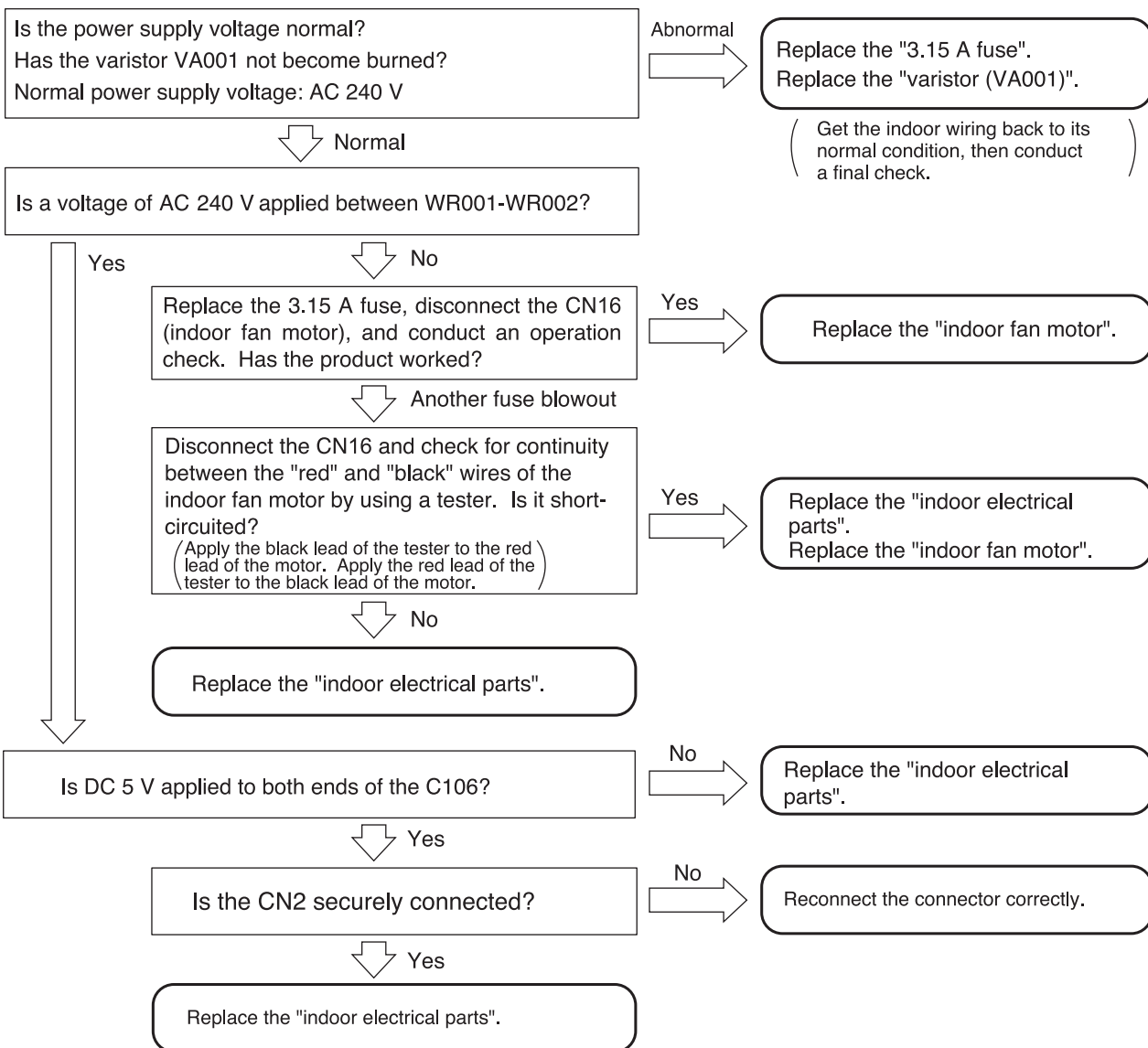

2.Failure phenomenon: The product will not receive a remote control signal.

[Situation] The product does not receive a remote control signal. It is not very responsive.

(The product does run normally in response to the emergency operation switch.)

[Estimated failure locations]

- Remote control failure, remote control low battery level, remote control poorly set
- Remote control light-receiving unit
- Connector loose, wire break
- Normal product (external factors: the remote control units for lighting equipment and other equipment, electrical noise, etc.)

[Cautions]

- Even if the product is trouble-free, a factor coming from outside the product may hamper the reception of signals from the remote control unit.
- Batteries may decline in capacity at low temperatures. Old batteries decline particularly much in voltage in the morning and evening of winter, resulting in the poor arrival of remote control signals. Instruct your users to use new alkaline batteries.

[Diagnosis flow]

Initiating troubleshooting

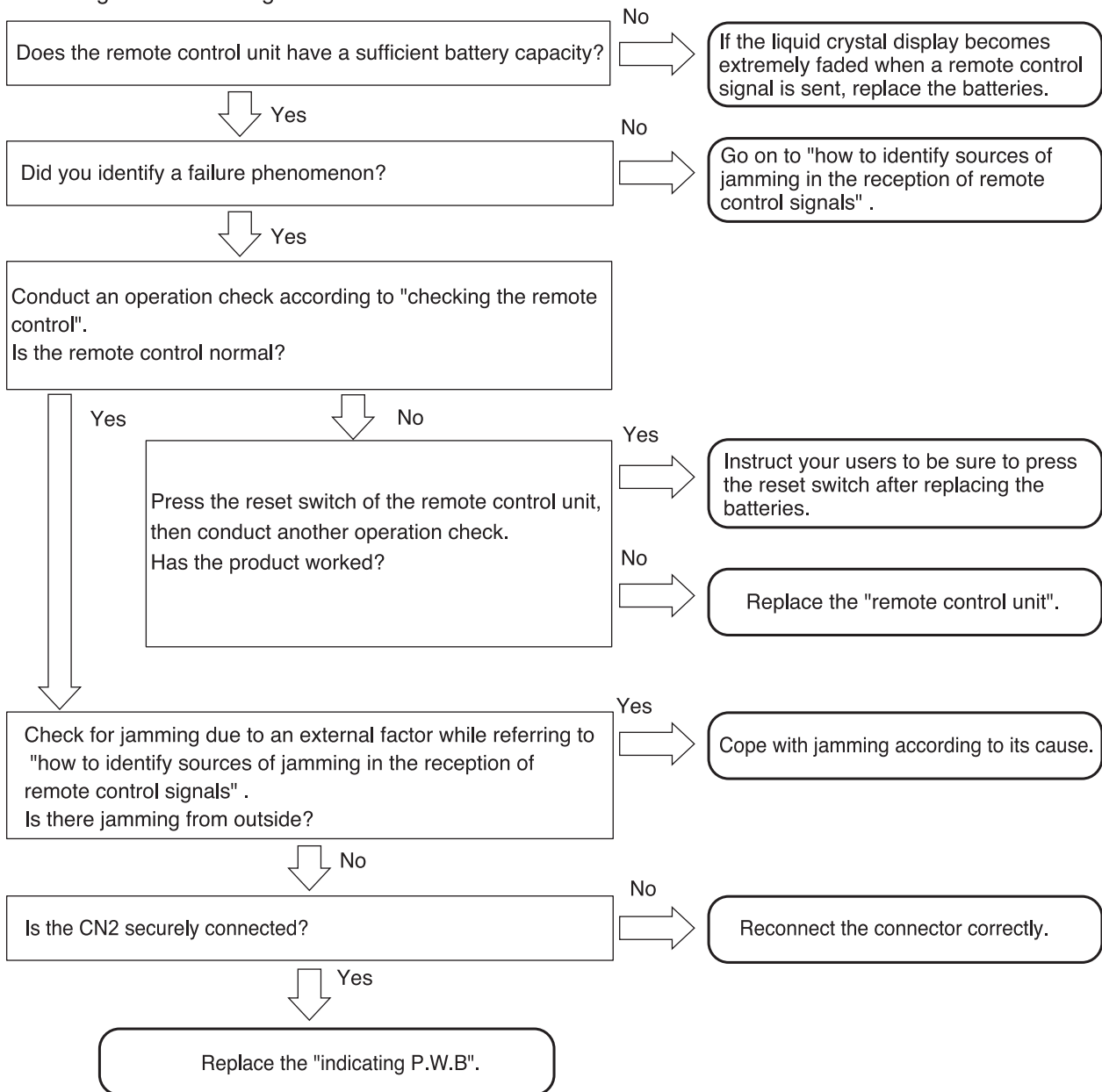

[Cautions in replacing the indicating P.W.B] Be sure to replace the indicating P.W.B. components.

How to identify sources of jamming in the reception of remote control signals

[Situation] The product may become poorly responsive to remote control signals due to external factors even though the product itself is trouble-free.

[Estimating sources of jamming] Identify the installation status of the air-conditioner and the indoor and outdoor environments to identify possible causes of the jamming.

- Indoor lighting equipment (quantity, type, location)
- Remote control units of other electrical products and equipment
- Is the grounding for the air-conditioner shared with other equipment?
- Are the surroundings of the air-conditioner clear of wireless antenna?
- Is the remote control light-receiving unit protected from direct sunlight?

[Checking and actions]

<p>Effects of lighting equipment (fluorescent lamps)</p>	<p><u>Checking points</u></p> <ul style="list-style-type: none"> · Turn on and off the lighting equipment and check for its effects on the reception of remote control signals. · When cold, the fluorescent lamp tends to emit infrared rays with wavelengths close to those used in remote control. <p>If you cannot detect the phenomenon about which your user is complaining at the time of your visit, such as "the product sometimes fails to receive remote control signals" and "the product fails to receive remote control signals in the morning alone", then turn off the lighting for about 20-30 minutes and wait for the fluorescent lamps to cool down before conducting another check.</p> <p>There are even cases where the product fails to receive remote control signals for 1 to 2 minutes only after the lighting equipment is turned on.</p> <ul style="list-style-type: none"> · The noise status may vary with the dimming of the lighting equipment. In the case of lighting equipment with a dimmer, therefore, conduct a check with all the light intensities. · If the lighting equipment is the source of the jamming, the remote control light-receiving unit output usually shows a noise waveform as shown in the right-hand figure. In the case of slight jamming, this kind of waveform will not cause practical problems. However, intense degrees of jamming will disable the reception of remote control signals. · When the fluorescent lamp is old and is flickering, it may cause disorders in the reception of remote control signals. <p><u>Actions proposed</u></p> <ol style="list-style-type: none"> 1. Make it hard for light of the lighting equipment to enter the remote control light-receiving unit. <ul style="list-style-type: none"> · Separate the lighting equipment from the indoor unit. · Raise the lighting equipment. · Cover the upper half of the light-receiving panel from its rear side with aluminum tape or black vinyl tape. <p>(This will also affect the reception of remote control signals. Therefore, set the range to be covered with tape to a range that is problem-free in practice, while checking the reception status.)</p> 2. Add an interference filter to the front panel of the remote control light-receiving unit. <ul style="list-style-type: none"> ※ Lighting equipment that produces strong jamming exists although rarely. Some problems may therefore be unsolvable by managing the air-conditioner side alone.
<p>Effects of the remote control units of other equipment</p>	<p><u>Checking points</u></p> <ul style="list-style-type: none"> · If, on the remote control unit of a TV or audio equipment, its sound volume key or something similar is left pressed, infrared signals become continuously sent, thereby jamming the reception of remote control signals. · Check how the remote control unit and related components are stored, thereby checking if there is any possibility that a button may be inadvertently left pressed on the remote control unit of other equipment. <p><u>Actions proposed</u></p> <p>If there is any such possibility, give explanations to your users to that effect and instruct them to exercise caution.</p>

Output waveform of the remote control light-receiving unit

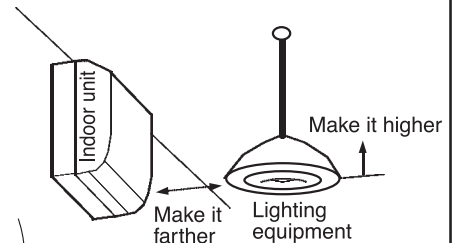
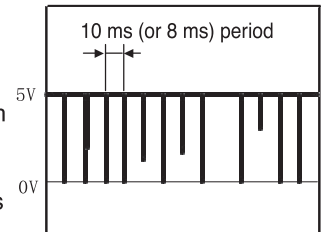

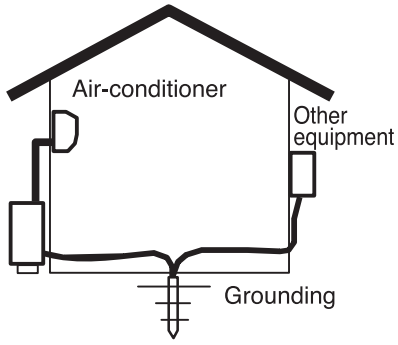
<p>Effects of other electrical products</p>	<p><u>Checking points</u></p> <ul style="list-style-type: none"> · Check the effects of light and power noises coming from other electrical products. · Turn on and off the electrical products, turn off the power and turn on the power, and check their effects on the reception of remote control signals. · For products whose operating states change, check the effects of each state. <p><u>Actions proposed</u></p> <ul style="list-style-type: none"> · Change the location relationship between the air-conditioner and the target products. · Use a different wall outlet for the target products.
<p>Sharing a grounding</p>	<p><u>Checking points</u></p> <ul style="list-style-type: none"> · Check for effects of electrical noises coming into the air-conditioner through grounding wires. · Check if the grounding works is for the air-conditioner alone or shared with other equipment. If there is any equipment that shares it, turn on and off that equipment and detach and reattach the power plugs and examine their effects on the reception of remote control signals. <p><u>Actions proposed</u></p> <ul style="list-style-type: none"> · Establish an independent grounding for the air-conditioner.  <p>The diagram illustrates a house with a roof and a ground symbol at the bottom. Inside the house, there are two electrical outlets. The left outlet is connected to a box labeled 'Air-conditioner'. The right outlet is connected to a box labeled 'Other equipment'. Both boxes are connected to a single horizontal line representing a shared grounding wire, which then connects to a ground symbol labeled 'Grounding'.</p>
<p>Effects of radio waves</p>	<p><u>Checking points</u></p> <ul style="list-style-type: none"> · Using a wireless transmitter near the air-conditioner may affect the reception of remote control signals. · Have your users try sending signals with a wireless transmitter and examine their effects on the reception of remote control signals. <p><u>Actions proposed</u></p> <ul style="list-style-type: none"> · Add a ferrite core to the power cord and F cable. · Add a ferrite core to the internal wiring of the indoor unit. · Move the wireless antenna.
<p>Effects of direct sunlight</p>	<p><u>Checking points</u></p> <ul style="list-style-type: none"> · Direct sunlight and other intense light make the remote control light-receiving unit less sensitive. · Check for any time zone where the remote control light-receiving unit of the indoor unit is affected by direct sunlight depending on the location of the sun and mirror reflection. <p><u>Actions proposed</u></p> <ul style="list-style-type: none"> · Block the sunlight to protect against direct sunlight.

3. Failure phenomenon: The compressor will not run.

[Situation] The compressor will not run (the same state as the thermometer turned off), the product receives remote control signals normally. The self-diagnosis lamp (LD301) of the outdoor unit blinks once or becomes turned off.

[Estimated failure locations] · Room temperature thermistor, heat exchanger thermistor
· Microcomputer peripheral circuit

[Diagnosis flow]

Initiating troubleshooting

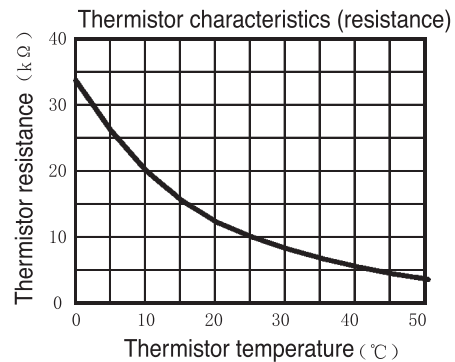
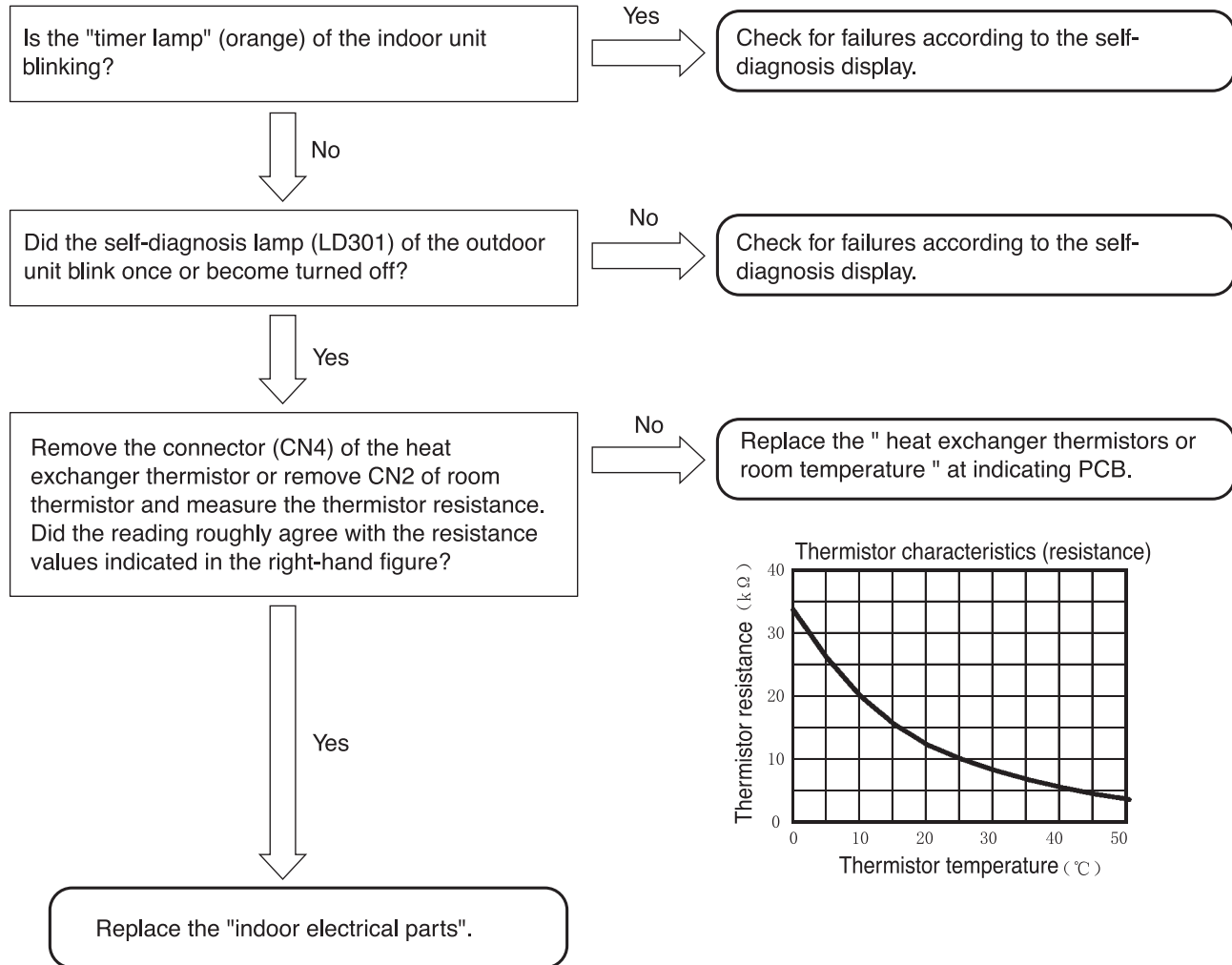

4. Failure phenomenon: The fan motor will not stop.

[Situation] I have conducted the stop operation on the product by remote control, but the indoor fan motor will not stop.
(It stopped about 10 minutes later.)

[Estimated failure locations]

- Indoor fan motor
- Fan motor drive circuit

[Diagnosis flow]

Initiating troubleshooting

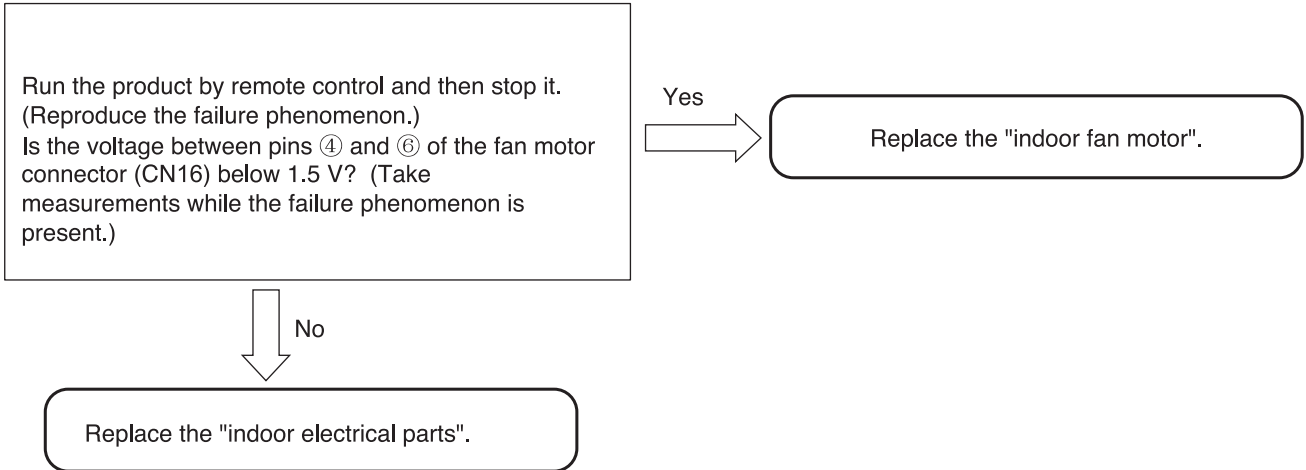

5. Timer lamp blinking: blinking once

[Situation] The timer lamp blinks one time and the product will not operate.
(This is not a sign of a breakdown.)

[Estimated failure locations] · Reversing valve defective.
· The refrigerating cycle block gas leak.

6. Timer lamp blinking: blinking twice

[Situation] The product is giving a display to indicate that it is performing forcible cooling.
(This is not a sign of a breakdown.)

7. Timer lamp blinking: blinking three times

[Situation] The timer lamp blinks three times and the product will not operate.

[Estimated failure locations] · Meltdown of the terminal board temperature fuse (the terminal board poorly inserted into the connecting cable)
· Outdoor communication circuit out of order

[Cautions] · If a terminal board is replaced to counter the meltdown of the terminal board temperature fuse, ensure that the connecting cable to be inserted into the terminal board has the appropriate dimension for peeling the insulation sheathing and that the insertion region is unbent before inserting it into the terminal board securely.

[Diagnosis flow]

Initiating troubleshooting

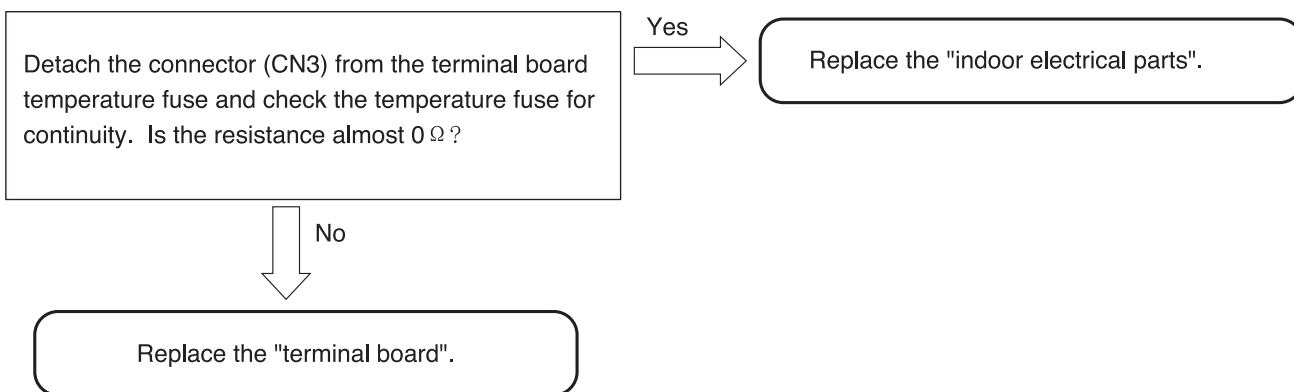

8. Timer lamp blinking: blinking four times

[Situation] The timer lamp blinks four times and the product will not operate.

[Estimated failure locations] · Outdoor unit error.
· Please confirm the times of the LD301 blinking, and then see the outdoor selfcheck table.

9. Timer lamp blinking: blinking 9 times

[Situation] The timer lamp blinks 9 times and the product will not run.

[Estimated failure location] • Loose connector, wire break, or short-circuit in the room temperature thermistor or heat exchanger thermistor.

[Cautions] • Starting the product by remote control will initiate failure detection.
(Merely turning on the power will not activate the failure detection function.)

[Diagnosis flow]
Initiating troubleshooting

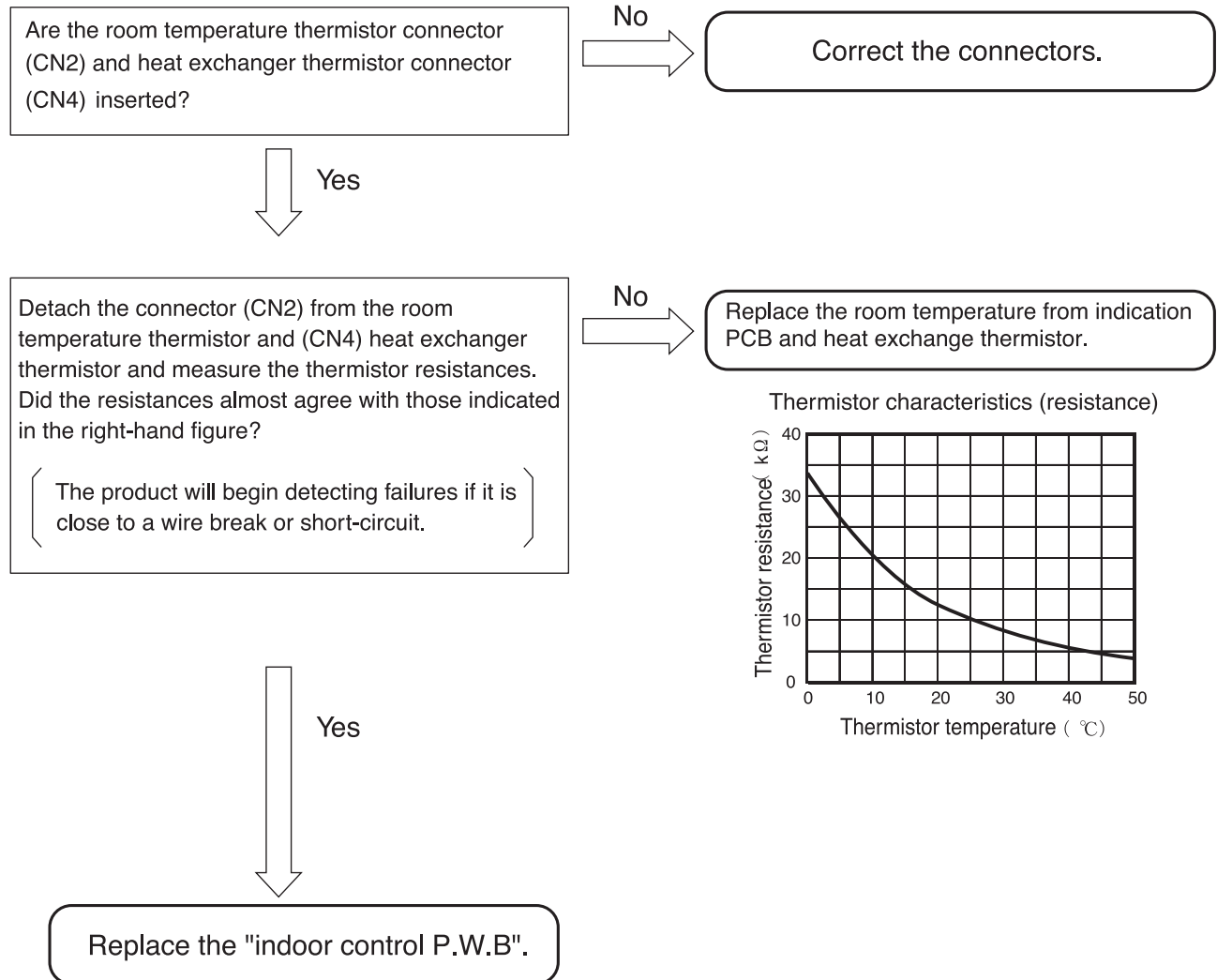

10. Timer lamp blinking: blinking 10 times

[Situation] The timer lamp blinks 10 times and the product will not run.

- [Estimated failure locations]
- Loose connector or wire break in the indoor fan motor
 - Indoor fan motor mechanically locked
 - Indoor fan motor
 - Indoor fan motor drive circuit

[Diagnosis flow]

Initiating troubleshooting

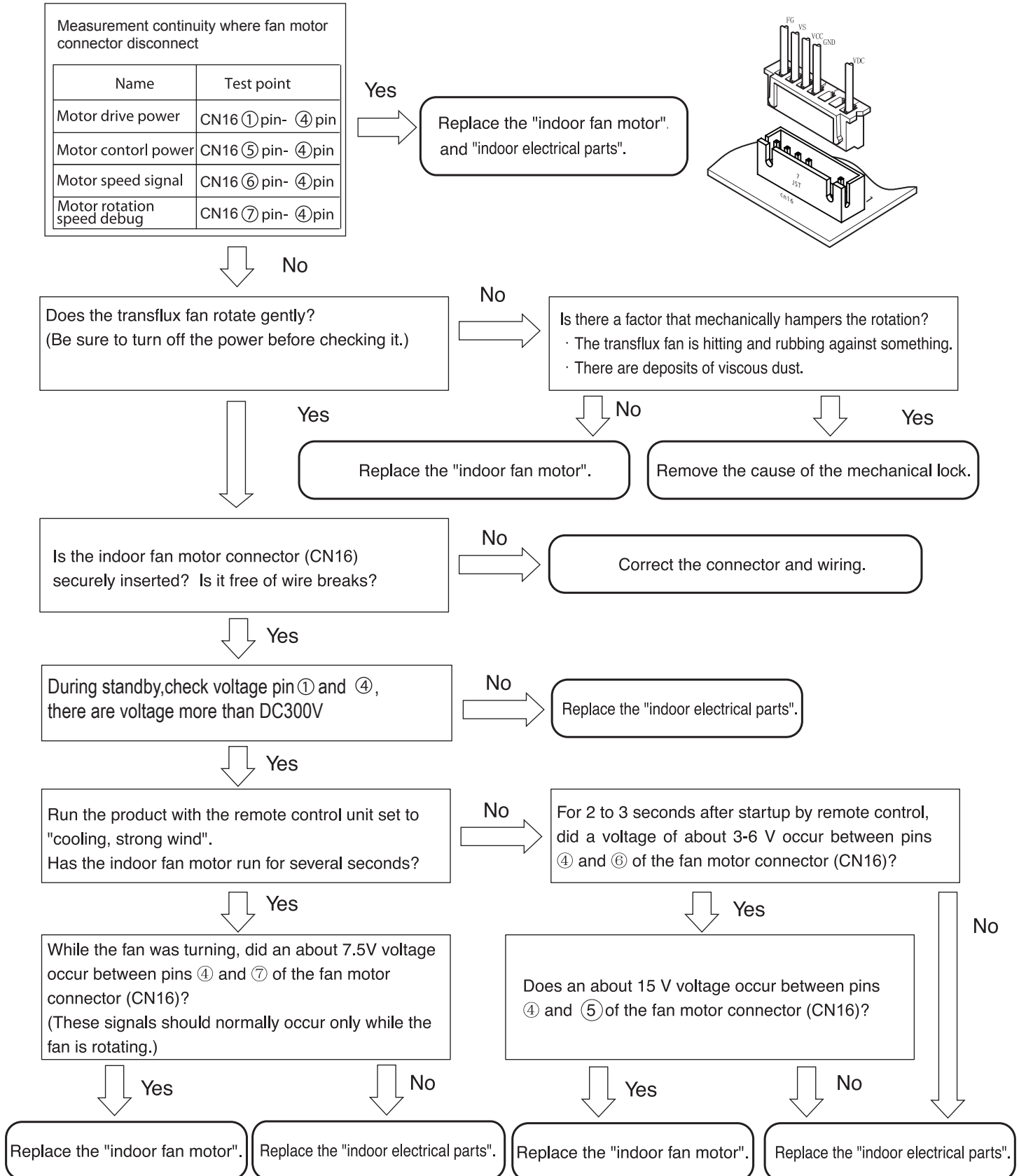

11. Timer lamp blinking :blinking 12 times

[Situation] The timer blinks 12 times and the product will not run.

- [Estimated failure locations]
- Erroneous connection in the indoor-outdoor connection line (connecting cable)
 - Forget to insert back self-check connector at CN27 of outdoor MAIN P.W.B
 - Wire break or poor insertion of the indoor-outdoor connection line (connecting cable)
 - Electrical parts in the outdoor unit (communication circuit, power circuit error)
 - Communication error due to noise in other home electronics
- ※This does not constitute a failure in the air-conditioner

[Cautions] • When lines 1 and 2 of connecting cable are erroneously connected (crossed), the product may not enter self-diagnosis display mode. If the self-diagnosis memory stores data about "timer lamp blinked 12 times", then, just in case, check if the connecting cable is not erroneously connected

[Diagnosis flow]

Initiating troubleshooting

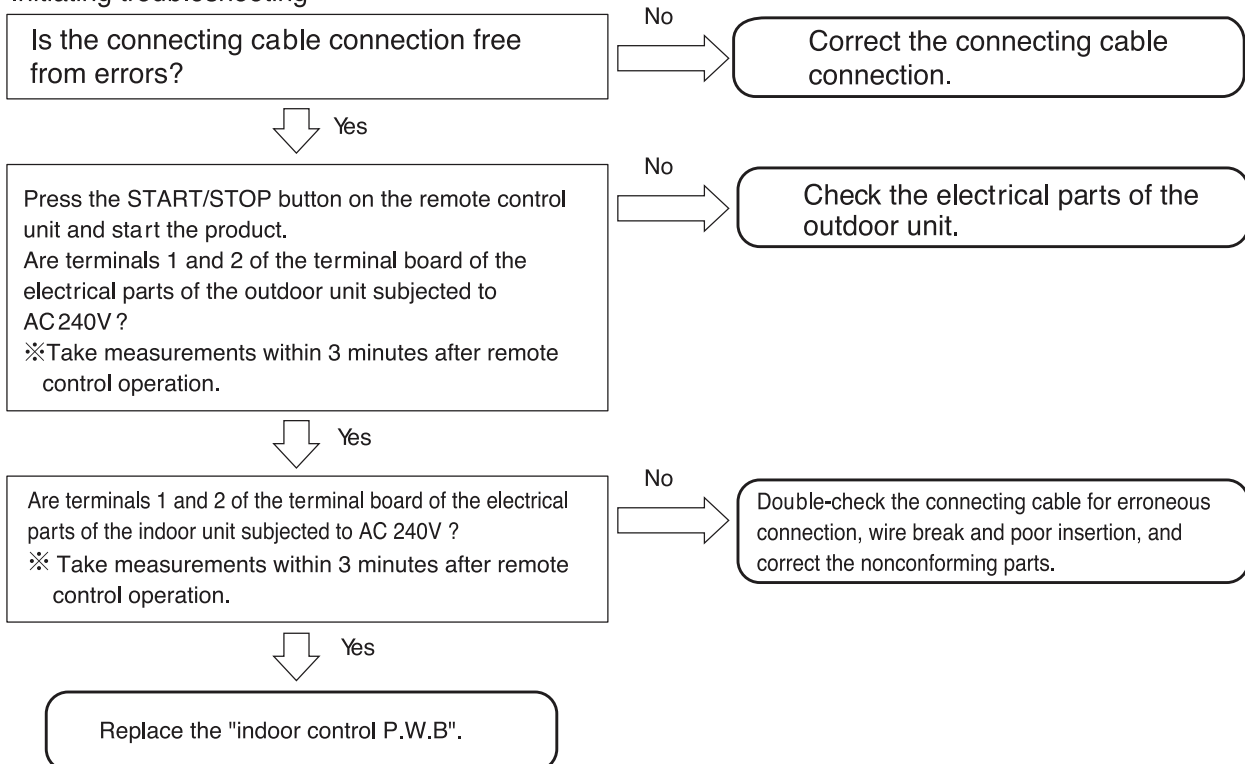

12. Timer lamp blinking :blinking 13 times

[Situation] The timer lamp blinks 13 times and the product will not run.

[Estimated failure location] • EEPROM, microcomputer

[Diagnosis flow]

Replace the "indoor control P.W.B".

Checking the electrical parts of outdoor unit

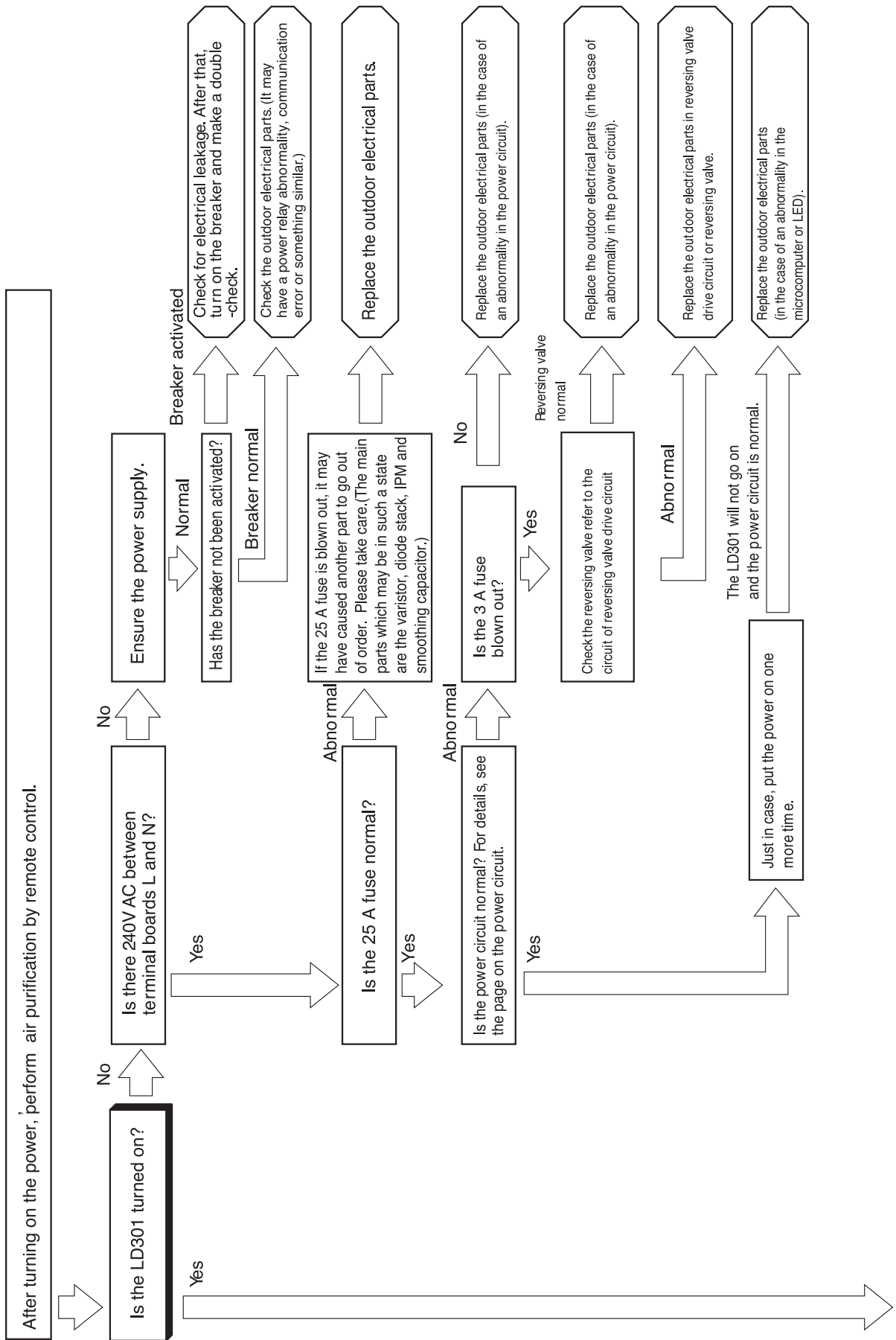

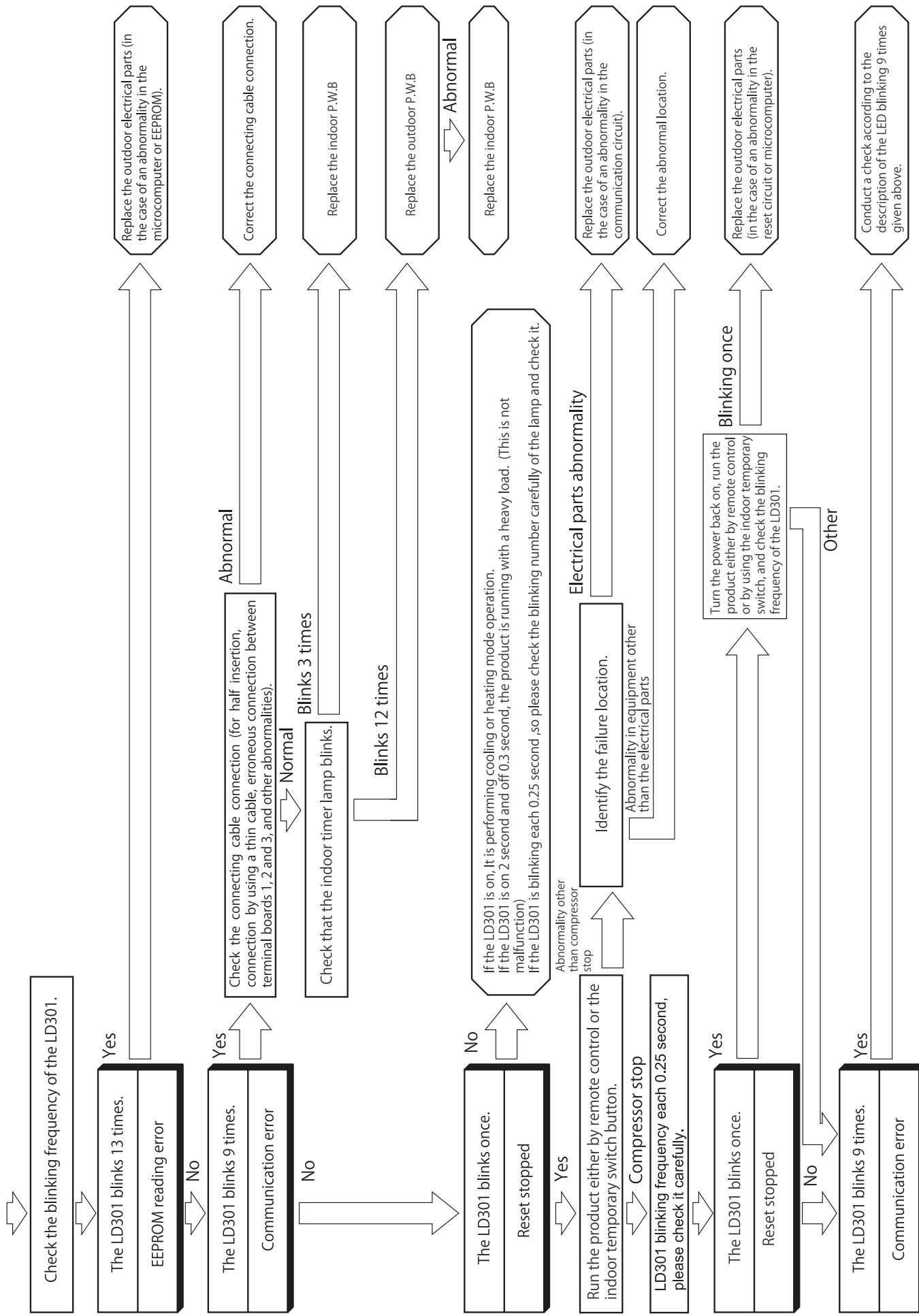

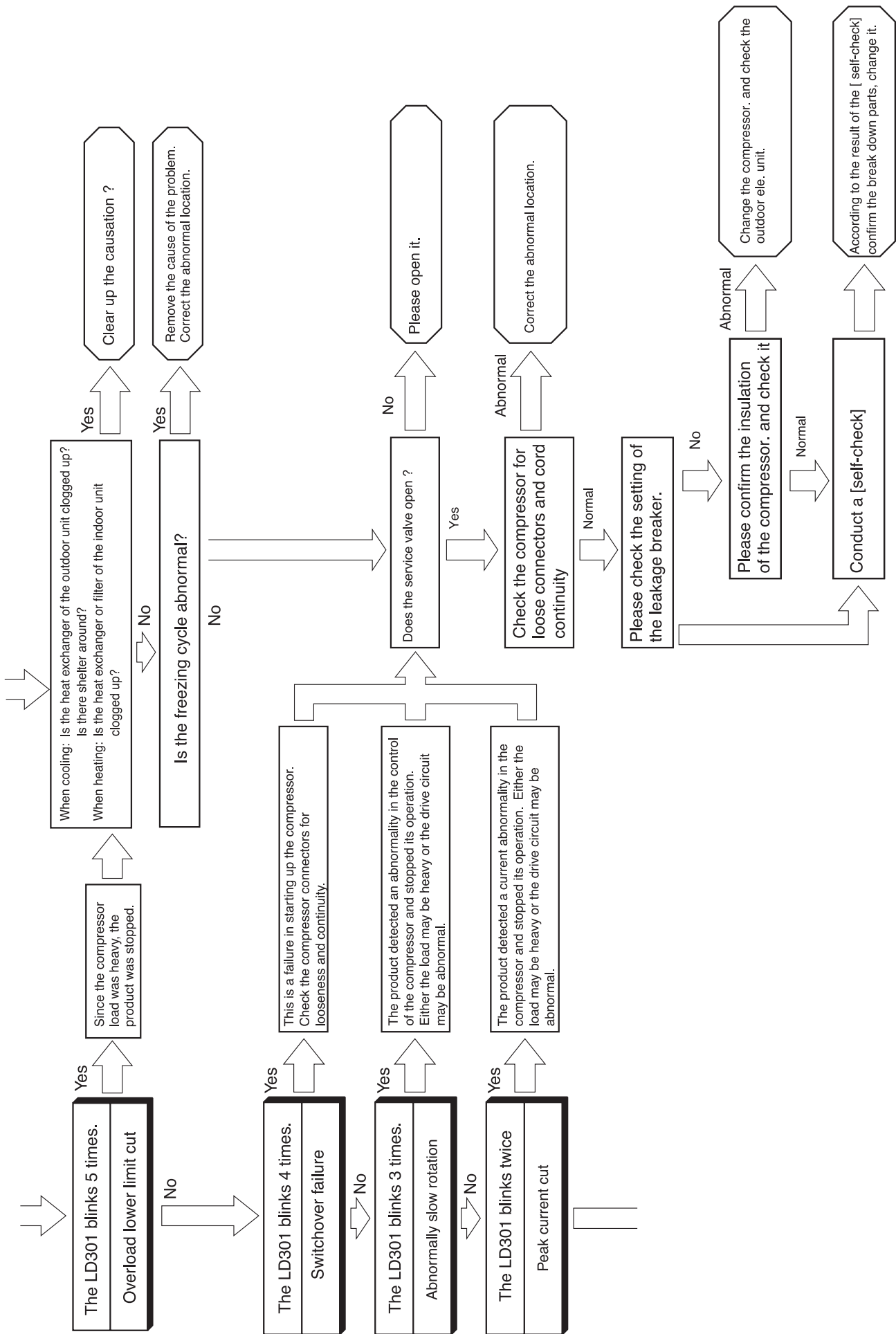

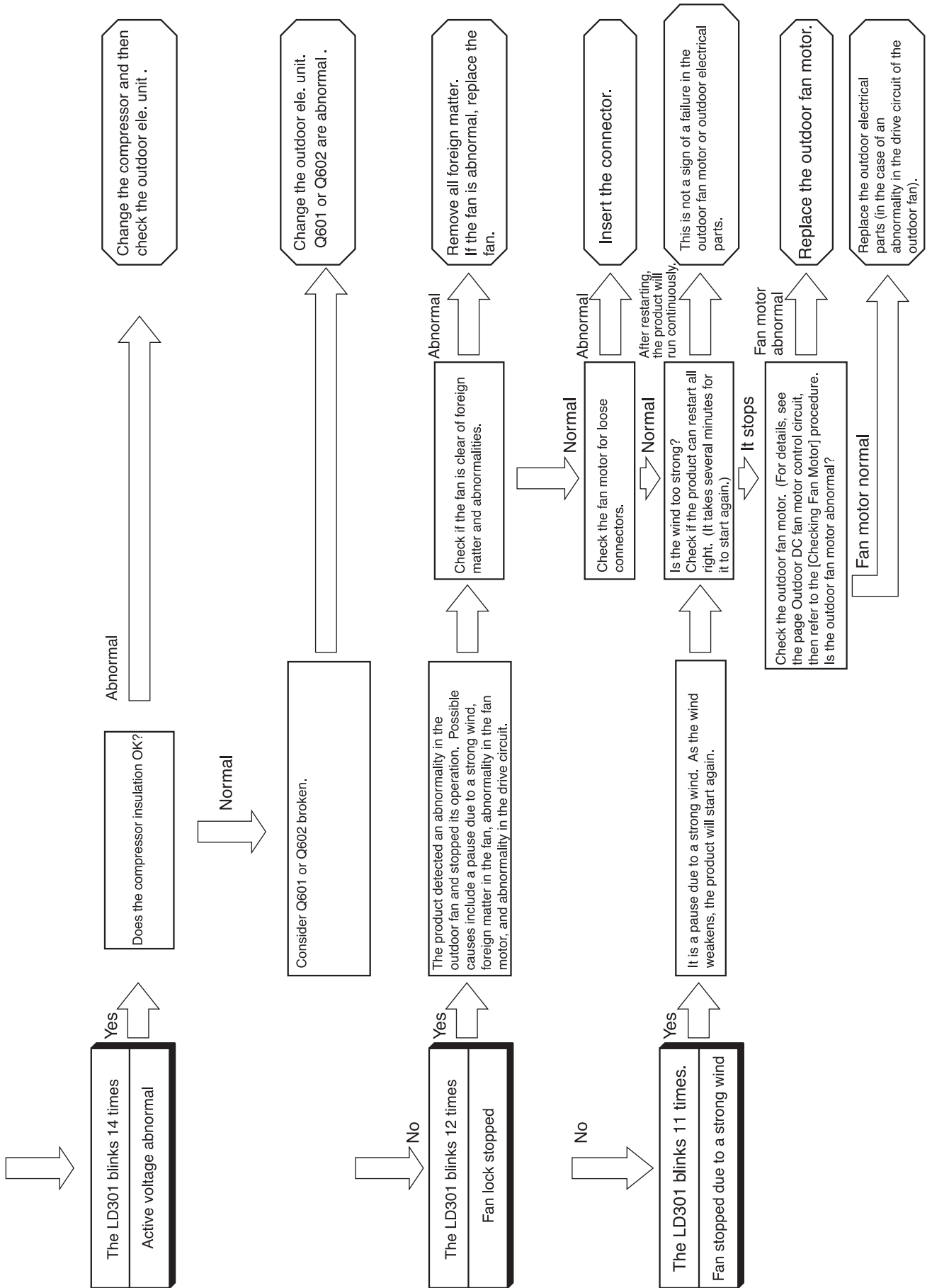

AUTO SWING FUNCTION

INPUT SIGNAL	PRESENT CONDITION			OPERATING SPECIFICATION	REFERENCE
	OPERATION	OPERATION MODE	AIR DEFLECTOR		
KEY INPUT	STOP	EACH MODE	STOP	ONE SWING (CLOSING AIR DEFLECTOR) ① DOWNWARD ② UPWARD	INITIALIZE AT NEXT OPERATION.
	DURING OPERATION	AUTO COOL COOL FAN DRY	STOP	STOP AT THE MOMENT.	
		AUTO HEAT HEAT	DURING SWINGING	START SWINGING ① DOWNWARD ② UPWARD ③ DOWNWARD	
THERMO. ON (INTERNAL FAN ON)	DURING OPERATION	DRY AUTO HEAT HEAT	DURING SWINGING	STOP AT THE MOMENT.	
THERMO. ON (INTERNAL FAN OFF)			TEMPORARY STOP	START SWING AGAIN.	
MAIN SWITCH ON	STOP	COOL FAN DRY HEAT	DURING SWINGING	STOP SWINGING TEMPORARILY. (SWING MODE IS CLEARED IF SWING COMMAND IS TRANSMITTED DURING TEMPORARY STOP.)	
			STOP DURING ONE SWING	INITIALIZE ① DOWNWARD ② UPWARD	
MAIN SWITCH OFF	DURING OPERATION	EACH MODE	STOP DURING ONE SWING	INITIALIZE ① DOWNWARD	
			DURING SWINGING DURING INITIALIZING	ONE SWING (CLOSING AIR DEFLECTOR) ① DOWNWARD ② UPWARD	INITIALIZE AT NEXT OPERATION.
CHANGE OF OPERATION	DURING OPERATION	EACH MODE	STOP	INITIALIZING CONDITION OF EACH MODE.	
			DURING SWINGING	STOP SWINGING AND MODE BECOMES INITIALIZING CONDITION.	

Forced cooling operation

The cooling operation can be forcibly performed for collecting refrigerant and inspecting failures. Do not perform the forced cooling operation continuously for long hours, because the compressor continues to be in operational status, regardless of room temperature.

<How to start the operation>

- The operation of the unit should be stopped.
- Press and hold the "Temporary operation SW" shown in the right figure for 5 sec.

<How to stop the operation>

- Press and hold the "Temporary operation SW" again.
- Or stop the operation using the remote controller.

※During the forced cooling operation, the "Timer indicator" blinks twice.

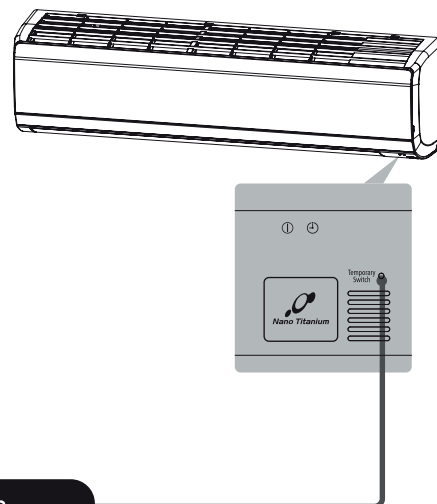

Temporary operation switch

When performing the forced cooling operation, turn the power on once. If you press and hold the switch for 5 sec or longer, the forced cooling operation starts. To stop the forced cooling operation, press the switch once again or stop the operation using the remote controller.

How to run the product with the outdoor unit test switch

If the indoor electrical parts is out of order and if you wish to run the outdoor unit

1. Remove the connection of indoor/outdoor connecting cable Terminal 3.
2. Turn on the outdoor terminal boards L and N (240 V AC).
3. Confirm that the "LD301" blinks once from the terminal side of the outdoor unit. Afterwards (when about 30 sec elapses after the power turns on), confirm that the "LD301" changes to blinking 9 times (communication error).
4. When the "LD301" is blinks 9 times, if you press the test switch, the "LD301" lights up.

If you release your finger from the test switch within 1 sec to 5 sec after pressing the switch, the forced cooling operation starts.

※(If you press the test switch for 5 sec or longer, the self-check diagnosis starts. In this case, turn the power off and start the procedure from once again.)

※(For the initialization of the expansion valve, it may take 1 min until the operation starts.)

5. When you press the test switch again for 1 sec or longer, the unit stops the operation.

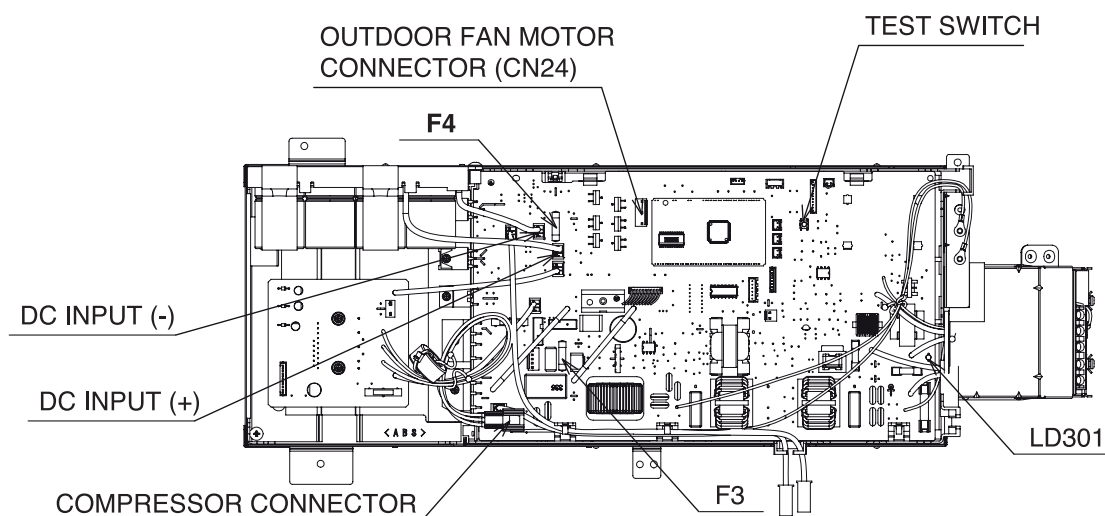

※Cautions

1. Applying power directly to the outdoor unit will cause a rush current to stress the outdoor unit. Therefore, if the indoor unit is not out of order, do not use the method described in 2).
2. Before making the connections, be sure to turn off the breaker.
3. Do not under any circumstances run the product for more than 5 minutes.
4. Doing work with the compressor connector removed will cause the LD301 to blink 4 times. It will not start.
5. For another test run, turn off the breaker and turn it back on. (The test switch is accepted only once after power-on. After operation by remote control, it is not accepted.)
6. When the operation with the test switch is over, turn off the breaker and set the connectors back.

HOW TO OPERATE THE OUTDOOR UNIT INDEPENDENTLY

1. Connect the large dia. pipe side and small dia. pipe side service valve using a pipe.

Connect the small diameter service valve and the large diameter service valve using the reducing union and copper pipe as shown on the right.

Charge refrigerant of 300g after vacuuming (※1)

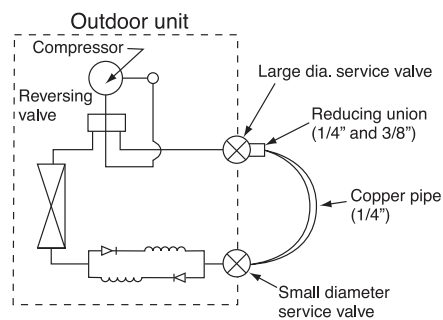

Parts to be prepared

- (1) Reducing union
1/4" (6.35 mm)
3/8" (9.52 mm)
- (2) Copper pipe (1/4" and 3/8")

Do not operate for more than 5 minutes

The operation method is the same as "How to operate using the connector to servicing the outdoor unit".

※1 The charging amount of 300g is equivalent to the load in normal operation.

SUMMARY OF TROUBLESHOOTING METHOD FOR INDOOR UNIT

MODEL : RAK-70PPD

Test Run

- 1) Power ON the unit and wait for 3 seconds.
- 2) Press and hold temp. switch for 5 seconds or longer.

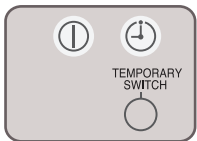

Checking the Room temperature thermistor.

- 1) Power off the unit.
- 2) Disconnect the thermistor wire from CN2 of Indicating P.W.B
- 3) Check the resistance value between the lead of thermistor. It shall be around $10k\Omega \pm 1k\Omega$.

Fan Motor Check

	Resistance	Operation
(+) Red (Pin1) & (-) Black(Pin4)	$> 2M\Omega/OL$	360VDC
(+) White (Pin5) & (-) Black(Pin4)	$35k\Omega \sim 40k\Omega$	15VDC
(+) Yellow (Pin6) & (-) Black(Pin4)	$230k\Omega \sim 250k\Omega$	3~6VDC
(+) Blue (Pin7) & (-) Black(Pin4)	$> 2M\Omega/OL$	7.5VDC

(+) Positive probe (-) Negative probe

[Circuit diagram of checking parts]

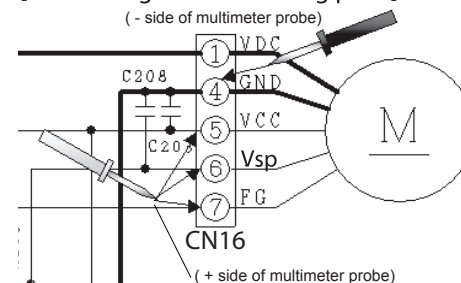

Checking the connection of 1, 2, 3 terminal to the indoor.

- 1) Power ON the unit.
- 2) After around 1 minute, check the AC voltage between terminal as below table.

Connection condition	Voltage value between terminal			Outdoor LD301 indication
	1 to 2	2 to 3	1 to 3	
All connection OK	240V	around 0.3V	240V	Off or 1 time blink
Terminal 1 no connection	240V	0.1-0.4V	240V	9 times blink
Terminal 2 no connection	240V	100 - 120V	120-140V	9 times blink
Terminal 3 no connection	240V	0.1-0.4V	240V	9 times blink

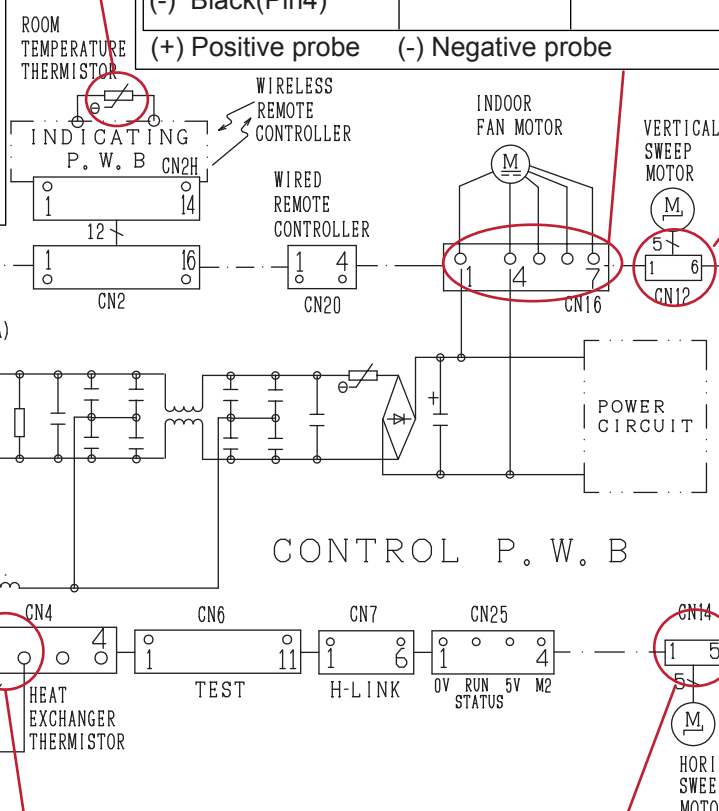

Checking the vertical stepping motor.

- 1) Power off the unit.
- 2) Disconnect the thermistor wire from CN12 of MAIN P.W.B.
- 3) Check the resistance value between pin 1 and 5. It shall be around $195 \pm 5\Omega$.

Checking the Terminal fuse continuity.

- 1) Power off the unit.
- 2) Disconnect the thermistor wire from CN3 of MAIN P.W.B
- 3) Check the resistance value between the wire. It shall be almost 0Ω .

Checking all the fuse continuity.

- There are 1 fuses inside the MAIN P.W.B.
- 1) Power off the unit.
 - 2) Check the continuity of FU1 fuse: It shall be (3.15A) .

Checking the Heat Exchanger thermistor.

- 1) Power off the unit.
- 2) Disconnect the thermistor wire from CN4 of MAIN P.W.B.
- 3) Check the resistance value between the wire of thermistor. It shall be around $10k\Omega \pm 1k\Omega$.

Checking the horizontal stepping motor.

- 1) Power off the unit.
- 2) Disconnect the thermistor wire from CN11 or 14 of MAIN P.W.B.
- 3) Check the resistance value between pin 1 and 5. It shall be around $195 \pm 5\Omega$.

SUMMARY OF TROUBLESHOOTING METHOD FOR OUTDOOR UNIT

MODEL : RAC-70NPD

Checking the IPM IC of IPM P.W.B.

- 1) Power off the unit.
 - 2) Disconnect compressor wire connector between compressor to IPM P.W.B.
 - 3) Check the diode value between below point :-
 - a) Terminal U, V, W (+ side of multimeter probe) to Terminal P (WHT wire) (- side of multimeter probe). It shall be around 0.40 to 0.43.
 - b) Terminal N (BLK wire) (+ side of multimeter probe) to Terminal U, V, W (- side of multimeter probe) It shall be around 0.40 to 0.43.
- **During normal running, DC voltage between below point are:-
- a) Terminal P & Terminal N shall be around 320V
 - b) Terminal U, V, W (+ side of multimeter probe) to Terminal N (- side of multimeter probe) shall be around 160V.

Checking the fan motor winding.

- 1) Power off the unit.
 - 2) Disconnect fan motor wire from CN24 of MAIN P.W.B.
 - 3) Check the resistance value between RED, WHT, BLK wire of fan motor. It shall be around 20Ω to 50Ω.
- **During normal running, DC voltage between RED, WHT, BLK wire of fan motor (+ side of multimeter probe) to Terminal N (R741 leg) (- side of multimeter probe) shall be around 160V.

Test Run

- 1) Remove Terminal 3 connection.
- 2) Power ON the unit and wait for 30 seconds.
- 3) Press and hold test switch for 5 seconds.

Checking the expansion valve winding.

- 1) Power off the unit.
- 2) Disconnect the expansion valve from CN15 of MAIN P.W.B.
- 3) Check the resistance value between wire of expansion valve as below:-
 - a) WHT to BRN
 - b) ORN to BRN
 - c) YEL to RED
 - d) BLU to RED
 It shall be around 46Ω ± 3.7Ω.

Checking the compressor motor winding.

- 1) Power off the unit.
- 2) Disconnect compressor wire connector between compressor to IPM P.W.B.
- 3) Check the resistance value between WHT, YEL, RED wire of compressor wire. It shall be same on all terminals between 1Ω to 3Ω.

Checking the reactor winding.

- 1) Power off the unit.
 - 2) Disconnect YEL and BRN wire at TAB3 and TAB4 from MAIN P.W.B.
 - 3) Check the resistance value between YEL & BRN wire of reactor. It shall be around 0.01Ω to 0.1Ω.
- ** During normal running, DC voltage between TAB 3 and TAB4 shall be 17V to 20V.

Checking all the fuse continuity. There are 5 fuses inside the MAIN P.W.B.

- 1) Power off the unit.
- 2) Check the continuity of below fuse:
 - a) F1 (25A) b) F5 (3.15A)
 - c) F6 (3.15A) d) F3 (3A)
 - e) F4 (2A)

Checking the power source.

- 1) Power ON the unit.
- 2) Check the AC voltage from power source between terminal L and N. It shall be around 240 ± 10 V

Checking the connection of 1, 2, 3 terminal to the indoor.

- 1) Power ON the unit.
- 2) After around 1 minute, check the AC voltage between terminal as below table.

Connection condition	Voltage value between terminal			Outdoor LD301 indication
	1 to 2	2 to 3	1 to 3	
All connection OK	240V	around 0.3V	240V	Off or 1 time blink
Terminal 1 no connection	240V	0.1-0.4V	240V	9 times blink
Terminal 2 no connection	240V	100 - 120V	120-140V	9 times blink
Terminal 3 no connection	240V	0.1-0.4V	240V	9 times blink

Checking the OH thermistor.

- 1) Power off the unit.
- 2) Disconnect the thermistor wire from CN8 of MAIN P.W.B.
- 3) Check the resistance value between the wire of thermistor. It shall be around 25kΩ ± 5kΩ.

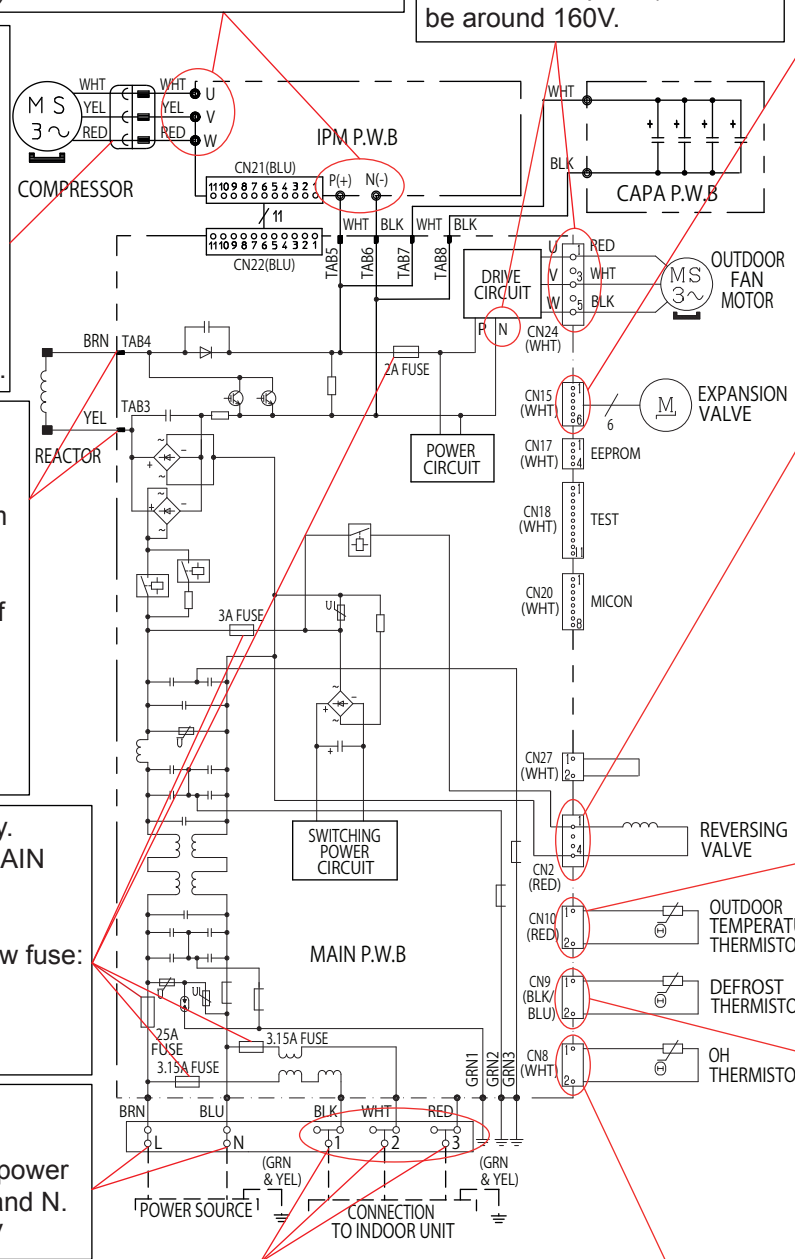

Checking the reversing valve winding.

- 1) Power off the unit.
- 2) Disconnect the reversing valve wire from CN2 of MAIN P.W.B.
- 3) Check the resistance value between the wire of reversing valve. It shall be around 1.9kΩ.

Checking the outdoor temperature thermistor.

- 1) Power off the unit.
- 2) Disconnect the thermistor wire from CN10 of MAIN P.W.B.
- 3) Check the resistance value between the wire of thermistor. It shall be around 1.7kΩ ± 0.3kΩ.

Checking the defrost thermistor.

- 1) Power off the unit.
- 2) Disconnect the thermistor wire from CN9 of MAIN P.W.B.
- 3) Check the resistance value between the wire of thermistor. It shall be around 1.7kΩ ± 0.3kΩ.

PARTS LIST AND DIAGRAM

INDOOR UNIT

MODEL RAK-70PPD

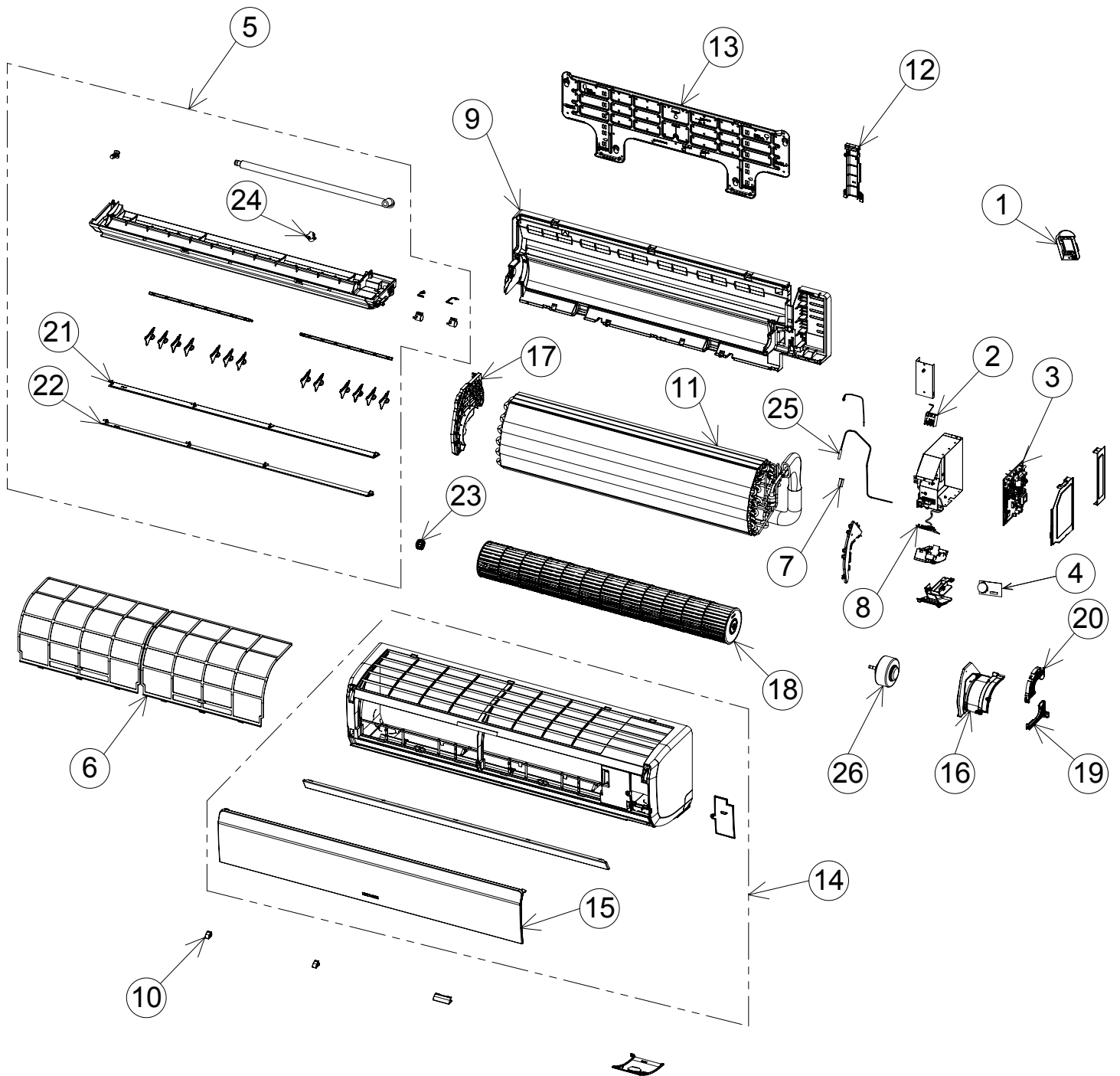

MODEL RAK-70PPD

NO.	PART NO. RAK-70PPD		Q'TY / UNIT	PARTS NAME
1	PMRAK-50PPA	R07	1	REMOTE CONTROL SUPPORT
2	PMRAK- 50PPD	R07	1	TERMINAL BOARD (3P)
3	PMRAK- 70PPD	R01	1	P.W.B (MAIN)
4	PMRAK- 70PPD	R02	1	P.W.B (MS)
5	PMRAK- 70PPD	R03	1	DRAIN PAN ASSY
6	PMRAK- 70PPD	R04	2	FILTER
7	PMRAS-10C8M	R03	1	THERMISTOR SUPPORT
8	PMRAS- 70YHA4	R02	1	PWB RECEIVER
9	PMRAS- 70YHA4	R04	1	CABINET
10	PMRAS-70YHA4	R05	1	CAP
11	PMRAS-70YHA4	R07	1	CYCLE-ASSY
12	PMRAS-70YHA4	R08	1	PIPE SUPPORT
13	PMRAS-70YHA4	R09	1	MOUNTING PLATE
14	PMRAS-70YHA4	R10	1	FRONT COVER ASSY
15	PMRAS-70YHA4	R11	1	FRONT PANEL
16	PMRAS-70YHA4	R12	1	FAN MOTOR BASE
17	PMRAS-70YHA4	R13	1	BEARING COVER
18	PMRAS-70YHA4	R14	1	TANGENTIAL FLOW FAN
19	PMRAS-70YHA4	R15	1	FAN MOTOR SUPP-RS
20	PMRAS-70YHA4	R16	1	FAN MOTOR SUPP-RU
21	PMRAS-70YHA4	R17	1	H-DEFLECT 1
22	PMRAS-70YHA4	R18	1	H-DEFLECT 2
23	PMRAS-72CHA3	017	1	P-BEARING ASSY
24	PMRAS-72CHA3	R01	1	AUTO SWEEP MOTOR
25	PMRAS-S18CPA	R14	1	THERMISTOR
26	PMRAS-VX13CET	R04	1	FAN MOTOR

PARTS LIST AND DIAGRAM

OUTDOOR UNIT

MODEL RAC-70NPD

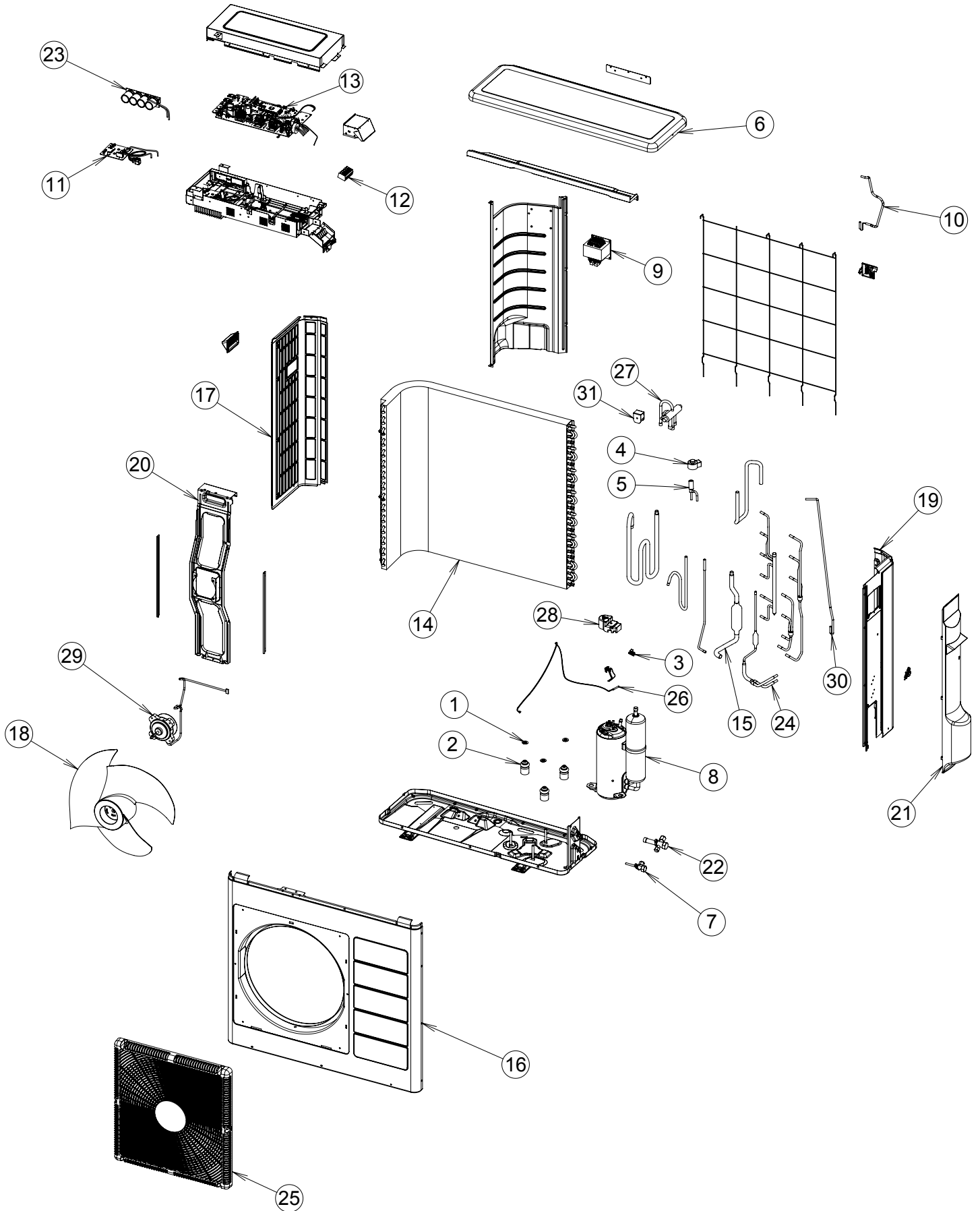

MODEL RAC-70NPD

NO.	PART NO. RAC-70NPD		Q'TY / UNIT	PARTS NAME
1	PMKPNT1	001	6	PUSH NUT
2	PMRAC-2226HV	805	3	COMPRESSOR RUBBER
3	PMRAC-25NH4	S09	1	OVERHEAT THERMISTOR SUPPORT
4	PMRAC-25NPA	S02	1	ELECTRICAL EXPANSION COIL
5	PMRAC-25NPA	S03	1	EXPANSION VALVE
6	PMRAC-30MH1	S05	1	TOP COVER
7	PMRAC-50NH4	S03	1	VALVE (2S)
8	PMRAC-50NPD	S01	1	COMPRESSOR
9	PMRAC-50YHA2	S04	1	REACTOR
10	PMRAC-50YHA2	S08	1	THERMISTOR (OUTSIDE TEMPERATURE)
11	PMRAC- 50YHA4	S02	1	IPM BOARD
12	PMRAC-50YHA4	S04	1	TERMINAL BOARD (5P)
13	PMRAC-70NPD	S01	1	P.W.B (MAIN)
14	PMRAC-70NPD	S02	1	CONDENSOR
15	PMRAC-70NPD	S03	1	STRAINER (COND)
16	PMRAC-70NPD	S04	1	CABINET
17	PMRAC-70YHA	908	1	SIDEPLATE L
18	PMRAC-70YHA	S07	1	PROPELLER FAN
19	PMRAC-70YHA	S09	1	SIDE PLATE R
20	PMRAC-70YHA	S12	1	SUPPORT (FAN MOTOR)
21	PMRAC-70YHA3	S03	1	SV-COVER
22	PMRAC-70YHA3	S04	1	VALVE (5S)
23	PMRAC-70YHA4	S02	1	CAPACITOR BOARD
24	PMRAC-70YHA4	S04	1	STRAINER(PIPE)
25	PMRAC-70NPD	S05	1	D-GRILL
26	PMRAC-80YHA	S14	1	THERMISTOR (OH)
27	PMRAC-S18CPA	S02	1	REVERSING VALVE
28	PMRAC-X13CX	906	1	OVERLOAD RELAY COVER
29	PMRAM-53NP2B	S10	1	FAN MOTOR
30	PMRAM-65QHA4	S12	1	THERMISTOR (DEFROST)
31	PMRAM-90NP5B	S09	1	MG-COIL (REVERSING VALVE)

HITACHI

RAK-70PPD / RAC-70NPD

PM NO. 0632E

Printed in Malaysia