

SERVICE MANUAL TECHNICAL INFORMATION

FOR SERVICE PERSONNEL ONLY

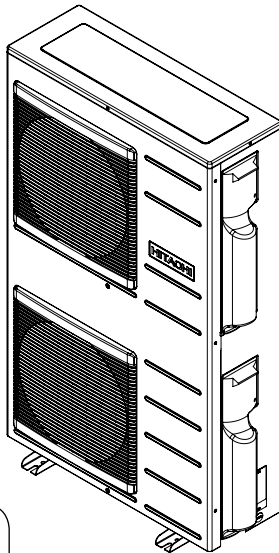

RAM-110NP6B

REFER TO THE FOUNDATION MANUAL

CONTENTS

SPECIFICATIONS.....	5
INSTALLATION.....	27
CONSTRUCTION AND DIMENSIONAL DIAGRAM.....	31
MAIN PARTS COMPONENT	32
WIRING DIAGRAM	35
CIRCUIT DIAGRAM	37
BLOCK DIAGRAM	41
PRINTED WIRING BOARD LOCATION DIAGRAM	43
BASIC MODE	49
REFRIGERATING CYCLE DIAGRAM.....	68
DESCRIPTION OF MAIN CIRCUIT OPERATION.....	70
TROUBLE SHOOTING	84
DISASSEMBLY AND REASSEMBLY.....	98
PARTS LIST AND DIAGRAM.....	106

SPECIFICATIONS

TYPE	DC INVERTER DUAL SYSTEM MULTI	
	OUTDOOR UNIT	
MODEL	RAM-110NP6B	
POWER SOURCE	1 ϕ , 220 - 240V, 50/60Hz	
TOTAL INPUT (W)	REFER TO THE SPECIFICATIONS PAGE	
TOTAL AMPERES (A)		
COOLING CAPACITY (kW)		
HEATING CAPACITY (B.T.U.)		
DIMENSIONS (mm)	W	855
	H	1450
	D	308
NET WEIGHT (kg)	118	

SPECIFICATIONS AND PARTS ARE SUBJECT TO CHANGE FOR IMPROVEMENT

ROOM AIR CONDITIONER OUTDOOR UNIT

SAFETY DURING REPAIR WORK

1. In order to disassemble and repair the unit in question, be sure to disconnect the power cord plug from the power outlet before starting the work.

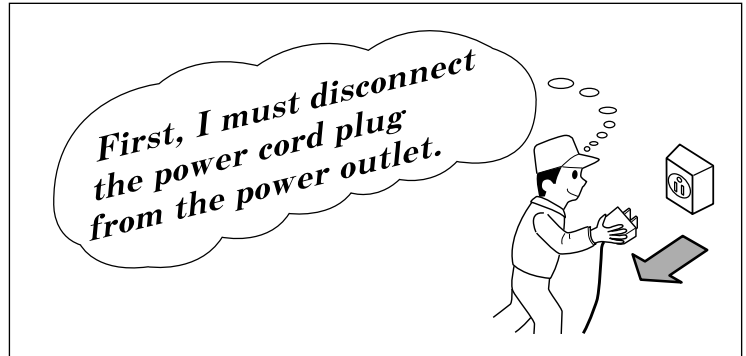

2. If it is necessary to replace any parts, they should be replaced with respective genuine parts for the unit, and the replacement must be effected in correct manner according to the instructions in the Service Manual of the unit.

If the contacts of electrical parts are defective, replace the electrical parts without trying to repair them.

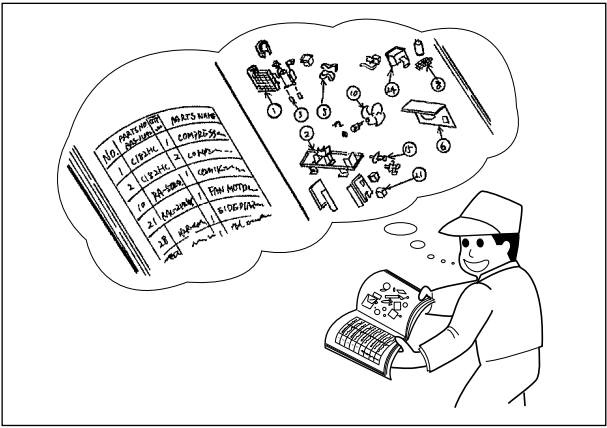

3. After completion of repairs, the initial state should be restored.
4. Lead wires should be connected and laid as in the initial state.
5. Modification of the unit by the user himself should absolutely be prohibited.
6. Tools and measuring instruments for use in repairs or inspection should be accurately calibrated in advance.
7. In installing the unit having been repaired, be careful to prevent the occurrence of any accident such as electrical shock, leak of current, or bodily injury due to the drop of any part.
8. To check the insulation of the unit, measure the insulation resistance between the power cord plug and grounding terminal of the unit. The insulation resistance should be $1M\Omega$ or more as measured by a 500V DC megger.
9. The initial location of installation such as window, floor or the other should be checked for being and safe enough to support the repaired unit again. If it is found not so strong and safe, the unit should be installed at the initial location after reinforced or at a new location.
10. Any inflammable object must not be placed about the location of installation.
11. Check the grounding to see whether it is proper or not, and if it is found improper, connect the grounding terminal to the earth.

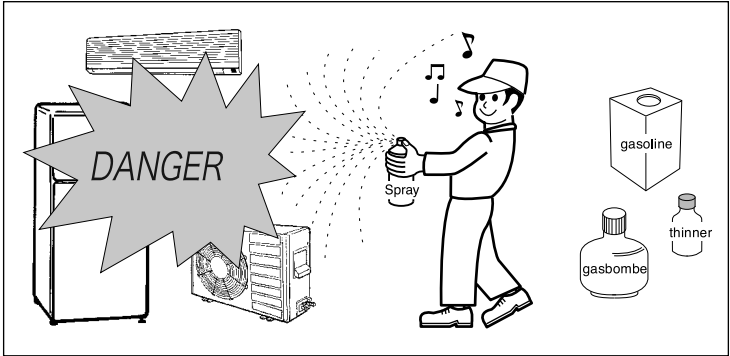

WORKING STANDARDS FOR PREVENTING BREAKAGE OF SEMICONDUCTORS

1. Scope

The standards provide for items to be generally observed in carrying and handling semiconductors in relative manufacturers during maintenance and handling thereof. (They apply the same to handling of abnormal goods such as rejected goods being returned).

2. Object parts

- (1) Micro computer
- (2) Integrated circuits (I.C.)
- (3) Field-effective transistor (F.E.T.)
- (4) P.C. boards or the like to which the parts mentioned in (1) and (2) of this paragraph are equipped.

3. Items to be observed in handling

- (1) Use a conductive container for carrying and storing of parts. (Even rejected goods should be handled in the same way).

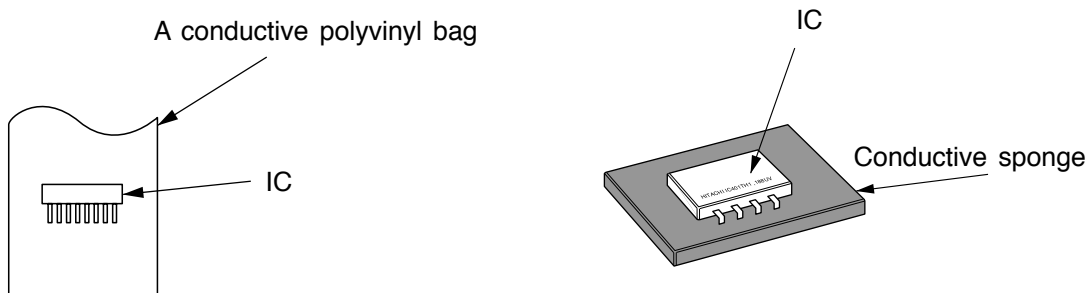

Fig. 1. Conductive container

- (2) When any part is handled uncovered (in counting, packing and the like), the handling person must always use himself as a body earth. (Make yourself a body earth by passing $1M\Omega$ earth resistance through a ring or bracelet).
- (3) Be careful not to touch the parts with your clothing when you hold a part even if a body earth is being taken.
- (4) Be sure to place a part on a metal plate with grounding.
- (5) Be careful not to fail to turn off power when you repair the printed circuit board. At the same time, try to repair the printed circuit board on a grounded metal plate.

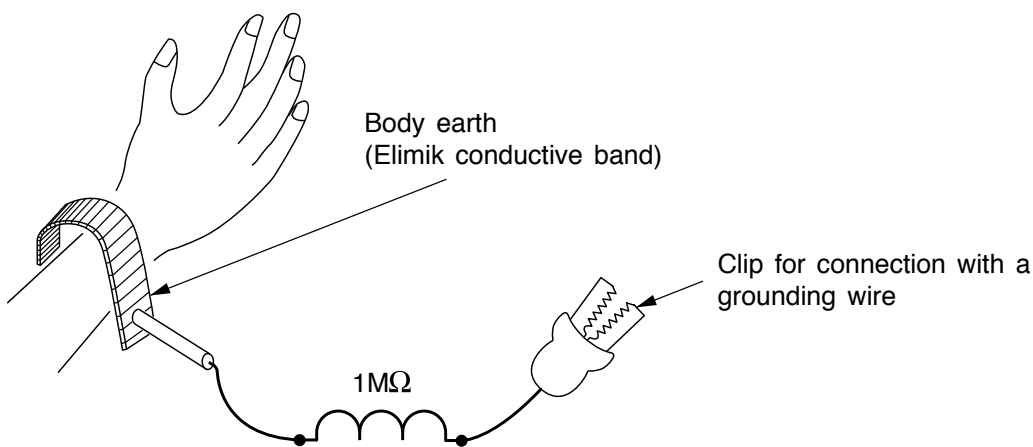

Fig. 2. Body Earth

(6) Use a three wire type soldering iron including a grounding wire.

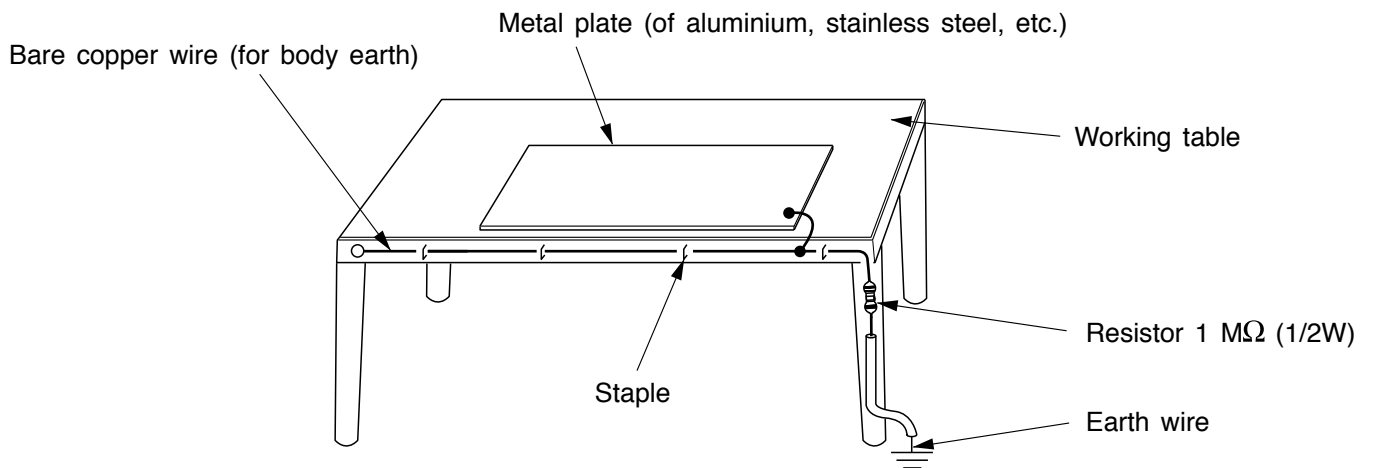

Fig. 3. Grounding of the working table

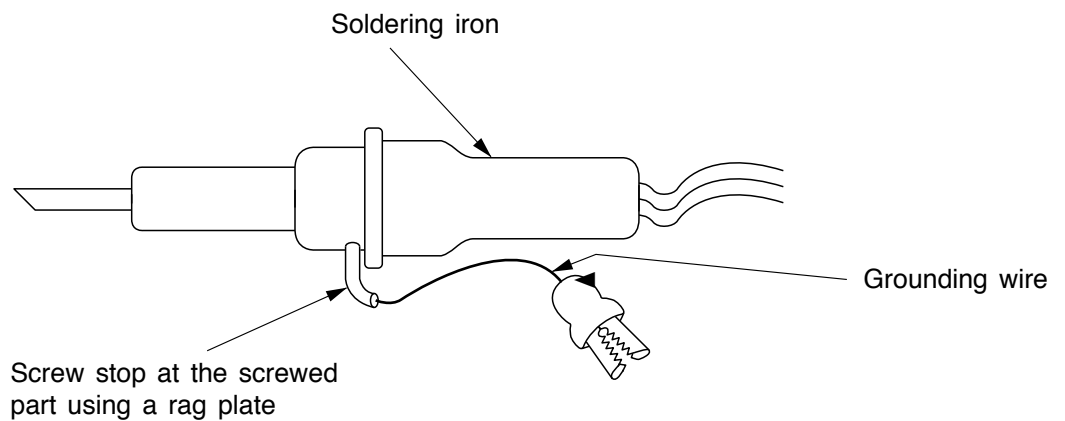

Fig. 4. Grounding a solder iron

Use a high insulation mode (100V, 10MΩ or higher) when ordinary iron is to be used.

(7) In checking circuits for maintenance, inspection or some others, be careful not to have the test probes of the measuring instrument short circuit a load circuit or the like.

 **CAUTION**

1. In quiet operation or stopping the running, slight flowing noise of refrigerant cycle is heard occasionally, but this noise is not abnormal for the operation.
2. When it thunders nearby, it is recommend to stop the operation and to disconnect the power cord plug from the power outlet for safety.
3. In the event of power failure, the air conditioner will restart automatically in the previously selected mode once the power is restored. In the event of power failure during TIMER operation, the air conditioner will not start automatically. Re-press ON/OFF button after 3 minutes from when the unit off or power recovery.
4. If the room air conditioner is stopped by adjusting thermostat, or miss operation, and re-start in a moment, there is occasion that the cooling and heating operation does not start for 3 minutes, it is not abnormal and this is the result of the operation of IC delay circuit. This IC delay circuit ensures that there is no danger of blowing fuse or damaging parts even if operation is restarted accidentally.
5. This room air conditioner should not be used at the cooling operation when the outside temperature is below -10°C (14°F).
6. This room air conditioner (the reverse cycle) should not be used when the outside temperature is below -15°C (5°F). If the reverse cycle is used under this condition, the outside heat exchanger is frosted and efficiency falls.
7. When the outside heat exchanger is frosted, the frost is melted by operating the hot gas system, it is not trouble that at this time fan stops and the vapour may rise from the outside heat exchanger.
8. This outdoor room airconditioner contain two refrigerant cycle with two compessor separately. Unit 1, 2, 3 and unit 4, 5, 6 are with different cycle
9. Unit 3 and unit 6 has to be connected to ensure no frost or ice remain at bottom of condensor.
10. Unit 2, 3 and unit 5, 6 has to be connected at least to ensure the compessor liability last longer.

SPECIFICATIONS

MODEL	RAM-110NP6B		
FAN MOTOR	40 W		
FAN MOTOR CAPACITOR	NO		
FAN MOTOR PROTECTOR	NO		
COMPRESSOR	JU1015D9		
COMPRESSOR MOTOR CAPACITOR	NO		
OVERLOAD PROTECTOR	YES		
OVERHEAT PROTECTOR	YES		
FUSE (for MICROPROCESSOR)	5.0A		
POWER RELAY	G4A		
POWER SWITCH	NO		
TEMPORARY SWITCH	NO		
SERVICE SWITCH	YES		
TRANSFORMER	NO		
VARISTOR	450NR		
NOISE SUPPRESSOR	YES		
THERMOSTAT	YES(IC)		
REMOTE CONTROL SWITCH (LIQUID CRYSTAL)	NO		
REFRIGERANT CHARGING VOLUME (Refrigerant 410A)	UNIT	1750g + 1750g	
	WITHOUT REFRIGERANT BECAUSE COUPLING IS FLARE TYPE.		
	PIPES	INDOOR 1, 2, 3	INDOOR 4, 5, 6
		MAX. 45m	MAX. 45m

※ This outdoor unit has two separated refrigerant cycle with two compressors which indoor units 1, 2, 3 are for upper refrigerant cycle and indoor units 4, 5, 6 are for lower refrigerant cycle. In case the total pipe length of each cycle is more than 35m, add refrigerant R410A at 20 gram per every meter exceeded.

SPECIFICATIONS FOR INDOOR UNITS COMBINATION

TYPE		DC INVERTER SIX SYSTEM MULTI COOLING AND HEATING
MODEL	OUTDOOR UNIT	RAM-110NP6B
PHESE/VOLTAGE/FREQUENCY		1ø, 220 - 240V, 50/60Hz
CIRCUIT AMPERES TO CONNECT (A)		30
COOLING (SIX UNITS)	CAPACITY (kW) (B.T.U./h)	10.60
		36,180
	TOTAL INPUT (W)	3,200
	EER (B.T.U./hW)	11.31
	TOTAL AMPERES (A)	14.70 - 13.50
POWER FACTOR (%)		99
HEATING (SIX UNITS)	CAPACITY (kW) (B.T.U./h)	13.60
		46,410
	TOTAL INPUT (W)	3,600
	EER (B.T.U./hW)	12.89
	TOTAL AMPERES (A)	16.50 ~ 15.20
POWER FACTOR (%)		99
MAXIMUM LENGTH OF PIPING		MAX. 45m (EACH CYCLE)
STANDARD		CE (EMC&LVD)

MODEL		RAM-110NP6B
PACKING (mm)	W	1,070
	H	1,590
	D	450
	cu.ft.	27.04
GROSS WEIGHT (kg)		133
FLARENUTSIZE (SMALL/LARGE)		6.35D/9.52DX6

OPERATION SCOPE

	INDOOR SUCTION TEMPERATURE (°C)	OUTDOOR SUCTION TEMPERATURE (°C)	INDOOR SUCTION HUMIDITY (%)
COOLING OPERATION SCOPE	16 ~ 32	-10 ~ 43	BELOW 80
HEATING OPERATION SCOPE	BELOW 27	-15 ~ 21	—

SIX ROOM SYSTEM MULTI R.A.C. RAM-110NP6B

COOL / HEAT CAPACITY SPEC. FOR INDOOR UNITS

COMBINATIONS TO BE ABLE TO OPERATE SIMULTANEOUSLY

Whichever indoor units are installed, cooling and heating capacity depends on how many and which indoor units are operating at that time.

		COOLING						HEATING					
		CAPACITY RATING (kW) (RANGE)	TOTAL	OUTDOOR UNIT			COP	CAPACITY RATING (kW) (RANGE)	TOTAL	OUTDOOR UNIT			COP
				POWER CONSUMPTION (W)	AMPERE (A) at 230V	AMPERE (A) 220 - 240				POWER CONSUMPTION (W)	AMPERE (A) at 230V	AMPERE (A) 220 - 240	
ONE UNIT	1.5	1.50 (1.00-2.20)	1.50	430 (200-480)	1.9	2.0 - 1.8	3.49	2.00 (1.10-2.20)	2.00	610 (200-650)	2.7	2.8 - 2.6	3.28
	1.8	1.80 (1.00-2.00)	1.80	495 (200-750)	2.2	2.3 - 2.1	3.64	2.50 (1.10-3.20)	2.50	690 (200-1050)	3.0	3.2 - 2.9	3.62
	2.5	2.50 (1.00-2.80)	2.50	700 (200-980)	3.1	3.2 - 2.9	3.57	3.90 (1.10-4.70)	3.90	1060 (200-1380)	4.7	4.9 - 4.5	3.68
	3.5	3.50 (1.00-3.90)	3.50	1030 (200-1280)	4.5	4.7 - 4.3	3.40	4.80 (1.10-5.80)	4.80	1320 (200-1870)	5.8	6.1 - 5.6	3.64
	5.0	5.00 (1.00-5.50)	5.00	1510 (200-1660)	6.6	6.9 - 6.4	3.31	6.50 (1.10-7.20)	6.50	1800 (200-2010)	7.9	8.3 - 7.6	3.61
TWO UNITS	1.5 + 1.5	1.50 + 1.50 (1.50-3.90)	3.00	920 (200-1000)	4.0	4.2 - 3.9	3.26	2.00 + 2.00 (1.50-4.70)	4.00	1060 (200-1380)	4.7	4.9 - 4.5	3.77
	1.5 + 1.8	1.50 + 1.80 (1.50-3.90)	3.30	1020 (200-1300)	4.5	4.7 - 4.3	3.24	2.00 + 2.50 (1.50-5.20)	4.50	1250 (200-1870)	5.5	5.7 - 5.3	3.60
	1.5 + 2.5	1.50 + 2.50 (1.50-4.50)	4.00	1180 (200-1250)	5.2	5.4 - 5.0	3.39	2.00 + 3.90 (1.50-6.50)	5.90	1620 (200-2010)	7.1	7.4 - 6.8	3.64
	1.5 + 3.5	1.50 + 3.50 (1.50-5.90)	5.00	1480 (200-1660)	6.5	6.8 - 6.2	3.38	2.00 + 4.80 (1.50-7.20)	6.80	1820 (200-2010)	8.0	8.4 - 7.7	3.74
	1.5 + 5.0	1.22 + 4.08 (1.50-5.90)	5.30	1600 (200-1660)	7.0	7.3 - 6.7	3.31	1.60 + 5.20 (1.50-7.20)	6.80	1820 (200-2010)	8.0	8.4 - 7.7	3.74
	1.8 + 1.8	1.80 + 1.80 (1.50-4.00)	3.60	1090 (200-1300)	4.7	5.0 - 4.5	3.33	2.50 + 2.50 (1.50-5.20)	5.00	1790 (200-1550)	5.7	5.9 - 5.4	3.88
	1.8 + 2.5	1.80 + 2.50 (1.50-4.60)	4.30	1280 (200-1450)	5.6	5.9 - 5.4	3.36	2.50 + 3.90 (1.50-6.30)	6.40	1700 (200-1920)	7.5	7.8 - 7.2	3.76
	1.8 + 3.5	1.80 + 3.50 (1.50-5.60)	5.30	1600 (200-1660)	7.0	7.3 - 6.7	3.31	2.33 + 4.47 (1.50-7.20)	6.80	1850 (200-2010)	8.1	8.5 - 7.8	3.68
	1.8 + 5.0	1.40 + 3.90 (1.50-5.60)	5.30	1600 (200-1660)	7.0	7.3 - 6.7	3.31	1.80 + 5.00 (1.50-7.20)	6.80	1820 (200-2010)	8.0	8.4 - 7.7	3.74
	2.5 + 2.5	2.50 + 2.50 (1.50-5.60)	5.00	1470 (200-1660)	6.5	6.7 - 6.2	3.40	3.40 + 3.40 (1.50-7.20)	6.80	1820 (200-2010)	8.0	8.4 - 7.7	3.74
	2.5 + 3.5	2.21 + 3.09 (1.50-5.70)	5.30	1600 (200-1660)	7.0	7.3 - 6.7	3.31	2.83 + 3.97 (1.50-7.20)	6.80	1820 (200-2010)	8.0	8.4 - 7.7	3.74
	3.5 + 3.5	2.65 + 2.65 (1.50-5.90)	5.30	1600 (200-1660)	7.0	7.3 - 6.7	3.31	3.40 + 3.40 (1.50-7.20)	6.80	1790 (200-2010)	7.9	8.2 - 7.5	3.80
	2.5 + 5.0	1.77 + 3.53 (1.50-5.90)	5.30	1600 (200-1660)	7.0	7.3 - 6.7	3.31	2.53 + 4.25 (1.50-7.20)	6.80	1790 (200-2010)	7.9	8.2 - 7.5	3.80
	3.5 + 5.0	2.18 + 3.12 (1.50-6.60)	5.30	1600 (200-1660)	7.0	7.3 - 6.7	3.31	2.89 + 3.91 (1.50-7.20)	6.80	1790 (200-2010)	7.9	8.2 - 7.5	3.80
	THREE UNITS	1.5 + 1.5 + 1.5	1.50 + 1.50 + 1.50 (1.50-5.00)	4.50	1370 (200-1680)	6.0	6.3 - 5.8	3.28	2.00 + 2.00 + 2.00 (1.50-6.20)	6.00	1680 (200-1550)	7.4	7.7 - 7.1
1.5 + 1.5 + 1.8		1.50 + 1.50 + 1.80 (1.50-6.00)	4.80	1470 (200-1680)	6.5	6.7 - 6.2	3.27	2.00 + 2.00 + 2.50 (1.50-6.60)	6.50	1740 (200-1760)	7.6	8.0 - 7.3	3.74
1.5 + 1.5 + 2.5		1.45 + 1.45 + 2.41 (1.50-6.00)	5.30	1600 (200-1660)	7.0	7.3 - 6.7	3.31	1.72 + 1.72 + 3.36 (1.50-7.20)	6.80	1800 (200-1860)	7.9	8.3 - 7.6	3.78
1.5 + 1.5 + 3.5		1.22 + 1.22 + 2.85 (1.50-6.00)	5.30	1600 (200-1680)	7.0	7.3 - 6.7	3.31	1.55 + 1.55 + 3.71 (1.50-7.20)	6.80	1800 (200-1860)	7.9	8.3 - 7.6	3.78
1.5 + 1.5 + 5.0		0.99 + 0.99 + 3.31 (1.50-6.00)	5.30	1600 (200-1680)	7.0	7.3 - 6.7	3.31	1.30 + 1.30 + 4.21 (1.50-7.20)	6.80	1800 (200-1860)	7.9	8.3 - 7.6	3.78
1.5 + 1.8 + 1.8		1.50 + 1.80 + 1.80 (1.50-6.00)	5.10	1550 (200-1660)	6.8	7.1 - 6.5	3.29	1.94 + 2.43 + 2.43 (1.50-7.20)	6.80	1790 (200-1860)	7.9	8.3 - 7.6	3.78
1.5 + 1.8 + 2.5		1.37 + 1.64 + 2.28 (1.50-6.00)	5.30	1600 (200-1680)	7.0	7.3 - 6.7	3.31	1.62 + 2.02 + 3.16 (1.50-7.20)	6.80	1800 (200-1860)	7.9	8.3 - 7.6	3.78
1.5 + 1.8 + 3.5		1.17 + 1.40 + 2.73 (1.50-6.00)	5.30	1600 (200-1680)	7.0	7.3 - 6.7	3.31	1.46 + 1.83 + 3.51 (1.50-7.20)	6.80	1800 (200-1860)	7.9	8.3 - 7.6	3.78
1.5 + 1.8 + 5.0		0.96 + 1.15 + 3.19 (1.50-6.00)	5.30	1600 (200-1680)	7.0	7.3 - 6.7	3.31	1.24 + 1.55 + 4.02 (1.50-7.20)	6.80	1800 (200-1860)	7.9	8.3 - 7.6	3.78
1.5 + 2.5 + 2.5		1.22 + 2.04 + 2.04 (1.50-6.00)	5.30	1600 (200-1680)	7.0	7.3 - 6.7	3.31	1.39 + 2.71 + 2.71 (1.50-7.20)	6.80	1800 (200-1860)	7.9	8.3 - 7.6	3.78
1.5 + 2.5 + 3.5		1.06 + 1.77 + 2.47 (1.50-6.00)	5.30	1600 (200-1680)	7.0	7.3 - 6.7	3.31	1.27 + 2.48 + 3.05 (1.50-7.20)	6.80	1800 (200-1860)	7.9	8.3 - 7.6	3.78
1.5 + 3.5 + 3.5		0.94 + 2.18 + 2.18 (1.50-6.00)	5.30	1600 (200-1680)	7.0	7.3 - 6.7	3.31	1.17 + 2.81 + 2.81 (1.50-7.20)	6.80	1800 (200-1860)	7.9	8.3 - 7.6	3.78
1.8 + 1.8 + 1.8		1.77 + 1.77 + 1.77 (1.50-6.00)	5.30	1600 (200-1680)	7.0	7.3 - 6.7	3.31	2.27 + 2.27 + 2.27 (1.50-7.20)	6.80	1800 (200-1860)	8.0	8.3 - 7.6	3.78
1.8 + 1.8 + 2.5		1.56 + 1.56 + 2.17 (1.50-6.40)	5.30	1600 (200-1680)	7.0	7.3 - 6.7	3.31	1.91 + 1.91 + 2.98 (1.50-7.20)	6.80	1800 (200-1860)	8.0	8.3 - 7.6	3.78
1.8 + 1.8 + 3.5		1.34 + 1.34 + 2.61 (1.50-6.60)	5.30	1600 (200-1680)	7.0	7.3 - 6.7	3.31	1.73 + 1.73 + 3.33 (1.50-7.20)	6.80	1800 (200-1860)	8.0	8.3 - 7.6	3.78
1.8 + 1.8 + 5.0		1.11 + 1.11 + 3.08 (1.50-6.60)	5.30	1600 (200-1680)	7.0	7.3 - 6.7	3.31	1.48 + 1.48 + 3.84 (1.50-7.20)	6.80	1800 (200-1860)	8.0	8.3 - 7.6	3.78
1.8 + 2.5 + 2.5		1.40 + 1.95 + 1.95 (1.50-6.60)	5.30	1600 (200-1680)	7.0	7.3 - 6.7	3.31	1.65 + 2.57 + 2.57 (1.50-7.20)	6.80	1800 (200-1860)	8.0	8.3 - 7.6	3.78
1.8 + 2.5 + 3.5		1.22 + 1.70 + 2.38 (1.50-6.60)	5.30	1600 (200-1680)	7.0	7.3 - 6.7	3.31	1.52 + 2.37 + 2.91 (1.50-7.20)	6.80	1800 (200-1860)	8.0	8.3 - 7.6	3.78
1.8 + 3.5 + 3.5		1.08 + 2.11 + 2.11 (1.50-6.60)	5.30	1600 (200-1680)	7.0	7.3 - 6.7	3.31	1.40 + 2.70 + 2.70 (1.50-7.20)	6.80	1800 (200-1860)	8.0	8.3 - 7.6	3.78
2.5 + 2.5 + 2.5		1.77 + 1.77 + 1.77 (1.50-6.60)	5.30	1600 (200-1680)	7.0	7.3 - 6.7	3.31	2.27 + 2.27 + 2.27 (1.50-7.20)	6.80	1800 (200-1860)	8.0	8.3 - 7.6	3.78
2.5 + 2.5 + 3.5	1.56 + 1.56 + 2.18 (1.50-6.60)	5.30	1600 (200-1680)	7.0	7.3 - 6.7	3.31	2.00 + 2.00 + 2.80 (1.50-7.20)	6.80	1800 (200-1860)	8.0	8.3 - 7.6	3.78	
FOUR UNITS	(1.5 + 1.5) + (1.5 + 1.5)	(1.50 + 1.50) + (1.50 + 1.50) (1.5-7.8)	6.00	1840 (200 - 2000)	8.1	8.4 - 7.7	3.26	(2.00 + 2.00) + (2.00 + 2.00) (1.5-9.4)	8.00	2120 (200 - 2760)	9.3	9.7 - 8.9	3.77
	(1.5 + 1.5) + (1.5 + 1.8)	(1.50 + 1.50) + (1.50 + 1.80) (1.5-7.8)	6.30	1940 (200 - 2300)	8.5	8.9 - 8.2	3.25	(2.00 + 2.00) + (2.00 + 2.50) (1.5-9.9)	8.50	2310 (200 - 3250)	10.1	10.6 - 9.7	3.68
	(1.5 + 1.5) + (1.5 + 2.5)	(1.50 + 1.50) + (1.50 + 2.50) (1.5-8.4)	7.00	2100 (200 - 2250)	9.2	9.6 - 8.8	3.33	(2.00 + 2.00) + (2.00 + 3.90) (1.5-11.2)	9.90	2680 (200 - 3390)	11.8	12.3 - 11.3	3.69
	(1.5 + 1.5) + (1.5 + 3.5)	(1.50 + 1.50) + (1.50 + 3.50) (1.5-9.8)	8.00	2400 (200 - 2660)	10.5	11.0 - 10.1	3.33	(2.00 + 2.00) + (2.00 + 4.80) (1.5-11.9)	10.80	2880 (200 - 3390)	12.6	13.2 - 12.1	3.75
	(1.5 + 1.5) + (1.5 + 5.0)	(1.50 + 1.50) + (1.22 + 4.08) (1.5-9.8)	8.30	2520 (200 - 2660)	11.1	11.6 - 10.6	3.29	(2.00 + 2.00) + (1.60 + 5.20) (1.5-11.9)	10.80	2880 (200 - 3390)	12.6	13.2 - 12.1	3.75
	(1.5 + 1.5) + (1.8 + 2.5)	(1.50 + 1.50) + (1.80 + 2.50) (1.5-9.5)	7.30	2200 (200 - 2450)	9.7	10.1 - 9.3	3.32	(2.00 + 2.00) + (2.50 + 3.90) (1.5-11.9)	10.40	2760 (200 - 3300)	12.1	12.7 - 11.6	3.77
	(1.5 + 1.5) + (1.8 + 3.5)	(1.50 + 1.50) + (1.80 + 3.50) (1.5-9.5)	8.30	2520 (200 - 2660)	11.1	11.6 - 10.6	3.29	(2.00 + 2.00) + (2.33 + 4.47) (1.5-11.9)	10.80	2910 (200 - 3390)	12.8	13.4 - 12.2	3.71
	(1.5 + 1.5) + (1.8 + 5.0)	(1.50 + 1.50) + (1.40 + 3.90) (1.5-9.8)	8.30	2520 (200 - 2660)	11.1	11.6 - 10.6	3.29	(2.00 + 2.00) + (1.80 + 5.00) (1.5-11.9)	10.80	2880 (200 - 3390)	12.6	13.2 - 12.1	3.75
	(1.5 + 1.5) + (2.5 + 3.5)	(1.50 + 1.50) + (2.21 + 3.09) (1.5-9.6)	8.30	2520 (200 - 2660)	11.1	11.6 - 10.6	3.29	(2.00 + 2.00) + (2.83 + 3.97) (1.5-11.9)	10.80	2880 (200 - 3390)	12.6	13.2 - 12.1	3.75
	(1.5 + 1.5) + (2.5 + 5.0)	(1.50 + 1.50) + (1.77 + 3.53) (1.5-9.8)	8.30	2520 (200 - 2660)	11.1	11.6 - 10.6	3.29	(2.00 + 2.00) + (2.55 + 4.25) (1.5-11.9)	10.80	2850 (200 - 3390)	12.5	13.1 - 12.0	3.79
	(1.5 + 1.5) + (3.5 + 5.0)	(1.50 + 1.50) + (2.18 + 3.12) (1.5-10.5)	8.30	2520 (200 - 2660)	11.1	11.6 - 10.6	3.29	(2.00 + 2.00) + (2.89 + 3.91) (1.5-11.9)	10.80	2850 (200 - 3390)	12.5	13.1 - 12.0	3.79
	(1.5 + 1.8) + (1.5 + 1.8)	(1.50 + 1.80) + (1.50 + 1.80) (1.5-7.8)	6.60	2040 (200 - 2600)	9.0	9.4 - 8.6	3.24	(2.00 + 2.50) + (2.00 + 2.50) (1.5-10.4)	9.00	2850 (200 - 3740)	12.5	13.1 - 12.0	3.16
(1.5 + 1.8) + (1.8 + 1.8)	(1.50 + 1.80) + (1.80 + 1.80) (1.5-7.8)	6.90	2100 (200 - 2600)	9.2	9.6 - 8.8	3.29	(2.00 + 2.50) + (2.50 + 2.50) (1.5-10.4)	9.50	2950 (200 - 3420)	10.3	10.8 - 9.9	4.04	
(1.5 + 1.8) + (1.8 + 2.5)	(1.50 + 1.80) + (1.80 + 2.50) (1.5-8.5)	7.60	2300 (200 - 2750)	10.1	10.6 - 9.7	3.30	(2.00 + 2.50) + (2.50 + 3.90) (1.5-11.5)	10.90	2760 (200 - 3790)	12.1	12.7 - 11.6	3.95	
(1.5 + 1.8) + (1.8 + 3.5)	(1.50 + 1.80) + (1.80 + 3.50) (1.5-9.5)	8.60	2620 (200 - 2960)	11.5	12.0 - 11.0	3.28	(2.00 + 2.50) + (2.33 + 4.47) (1.5-12.4)	11.30	2910 (200 - 3880)	12.8	13.4 - 12.2	3.88	
(1.5 + 1.8) + (1.8 + 5.0)	(1.50 + 1.80) + (1.40 + 3.90) (1.5-9.8)	8.60	2620 (200 - 2960										

(1.5 + 1.8) + (2.5 + 2.5)	8.3	(1.50 + 1.80) + (2.50 + 2.50) (1.5-9.5)	8.30	2490 (200 ~ 2960)	10.9	11.4 - 10.5	3.33	(2.00 + 2.50) + (3.40 + 3.40) (1.5-12.4)	11.30	2880 (200 ~ 3880)	12.6	13.2 - 12.1	3.92
(1.5 + 1.8) + (2.5 + 3.5)	9.3	(1.50 + 1.80) + (2.21 + 3.09) (1.5-9.6)	8.60	2620 (200 ~ 2960)	11.5	12.0 - 11.0	3.28	(2.00 + 2.50) + (2.83 + 3.97) (1.5-12.4)	11.30	2880 (200 ~ 3880)	12.6	13.2 - 12.1	3.92
(1.5 + 1.8) + (2.5 + 3.0)	10.8	(1.50 + 1.80) + (1.77 + 3.53) (1.5-9.8)	8.60	2620 (200 ~ 2960)	11.5	12.0 - 11.0	3.28	(2.00 + 2.50) + (2.55 + 4.25) (1.5-12.4)	11.30	2850 (200 ~ 3880)	12.5	13.1 - 12.0	3.86
(1.5 + 1.8) + (3.5 + 3.5)	10.3	(1.50 + 1.80) + (2.65 + 2.65) (1.5-9.8)	8.60	2620 (200 ~ 2960)	11.5	12.0 - 11.0	3.28	(2.00 + 2.50) + (3.40 + 3.40) (1.5-12.4)	11.30	2850 (200 ~ 3880)	12.5	13.1 - 12.0	3.86
(1.5 + 1.8) + (3.5 + 5.0)	11.8	(1.50 + 1.80) + (2.18 + 3.12) (1.5-10.5)	8.60	2620 (200 ~ 2960)	11.5	12.0 - 11.0	3.28	(2.00 + 2.50) + (2.89 + 3.91) (1.5-12.4)	11.30	2850 (200 ~ 3880)	12.5	13.1 - 12.0	3.86
(1.5 + 2.5) + (1.5 + 2.5)	8.0	(1.50 + 2.50) + (1.50 + 2.50) (1.5-9)	8.00	2360 (200 ~ 2500)	10.4	10.8 - 9.9	3.39	(2.00 + 3.90) + (2.00 + 3.90) (1.5-13)	11.80	3240 (200 ~ 4020)	14.2	14.9 - 13.6	3.64
(1.5 + 2.5) + (2.5 + 2.5)	9.0	(1.50 + 2.50) + (2.50 + 2.50) (1.5-10.1)	9.00	2650 (200 ~ 2910)	11.6	12.2 - 11.2	3.40	(2.00 + 3.90) + (3.40 + 3.40) (1.5-13.7)	12.70	3440 (200 ~ 4020)	15.1	15.8 - 14.5	3.69
(1.5 + 2.5) + (2.5 + 3.5)	10.0	(1.50 + 2.50) + (2.21 + 3.09) (1.5-10.2)	9.30	2780 (200 ~ 2910)	12.2	12.8 - 11.7	3.35	(2.00 + 3.90) + (2.83 + 3.97) (1.5-13.7)	12.70	3440 (200 ~ 4020)	15.1	15.8 - 14.5	3.69
(1.5 + 2.5) + (2.5 + 5.0)	11.5	(1.50 + 2.50) + (1.77 + 3.53) (1.5-10.4)	9.30	2780 (200 ~ 2910)	12.2	12.8 - 11.7	3.35	(2.00 + 3.90) + (2.55 + 4.25) (1.5-13.7)	12.70	3410 (200 ~ 4020)	15.0	15.7 - 14.4	3.72
(1.5 + 2.5) + (3.5 + 3.5)	11.0	(1.50 + 2.50) + (2.65 + 2.65) (1.5-10.4)	9.30	2780 (200 ~ 2910)	12.2	12.8 - 11.7	3.35	(2.00 + 3.90) + (3.40 + 3.40) (1.5-13.7)	12.70	3410 (200 ~ 4020)	15.0	15.7 - 14.4	3.72
(1.5 + 2.5) + (3.5 + 5.0)	12.5	(1.50 + 2.50) + (2.18 + 3.12) (1.5-11.1)	9.30	2780 (200 ~ 2910)	12.2	12.8 - 11.7	3.35	(2.00 + 3.90) + (2.89 + 3.91) (1.5-13.7)	12.70	3410 (200 ~ 4020)	15.0	15.7 - 14.4	3.72
(1.5 + 3.5) + (1.5 + 3.5)	10.0	(1.50 + 3.50) + (1.50 + 3.50) (1.5-11.8)	10.00	2960 (200 ~ 3320)	13.0	13.6 - 12.5	3.38	(2.00 + 4.80) + (2.00 + 4.80) (1.5-14.4)	13.60	3640 (200 ~ 4020)	16.0	16.7 - 15.3	3.74
(1.5 + 3.5) + (3.5 + 3.5)	12.0	(1.50 + 3.50) + (2.65 + 2.65) (1.5-11.8)	10.30	3080 (200 ~ 3320)	13.5	14.1 - 13.0	3.34	(2.00 + 4.80) + (3.40 + 3.40) (1.5-14.4)	13.60	3610 (200 ~ 4020)	15.9	16.6 - 15.2	3.77
(1.5 + 3.5) + (3.5 + 5.0)	13.5	(1.50 + 3.50) + (2.18 + 3.12) (1.5-12.5)	10.30	3080 (200 ~ 3320)	13.5	14.1 - 13.0	3.34	(2.00 + 4.80) + (2.89 + 3.91) (1.5-14.4)	13.60	3610 (200 ~ 4020)	15.9	16.6 - 15.2	3.77
(1.5 + 5.0) + (1.5 + 5.0)	13.0	(1.22 + 4.08) + (1.22 + 4.08) (1.5-11.8)	10.60	3200 (200 ~ 3320)	14.1	14.7 - 13.5	3.31	(1.80 + 5.20) + (1.80 + 5.20) (1.5-14.4)	13.60	3640 (200 ~ 4020)	16.0	16.7 - 15.3	3.74
(1.8 + 1.8) + (1.8 + 1.8)	7.2	(1.80 + 1.80) + (1.80 + 1.80) (1.5-8)	7.20	2160 (200 ~ 2600)	9.5	9.9 - 9.1	3.33	(2.50 + 2.50) + (2.50 + 2.50) (1.5-10.4)	10.00	2580 (200 ~ 3100)	11.3	11.8 - 10.9	3.88
(1.8 + 1.8) + (1.8 + 2.5)	7.9	(1.80 + 1.80) + (1.80 + 2.50) (1.5-8.6)	7.90	2360 (200 ~ 2750)	10.4	10.8 - 9.9	3.35	(2.50 + 2.50) + (2.50 + 3.90) (1.5-11.5)	11.40	2990 (200 ~ 3470)	13.1	13.7 - 12.6	3.81
(1.8 + 2.5) + (1.8 + 2.5)	8.6	(1.80 + 2.50) + (1.80 + 2.50) (1.5-9.2)	8.60	2560 (200 ~ 2900)	11.2	11.8 - 10.8	3.36	(2.50 + 3.90) + (2.50 + 3.90) (1.5-12.6)	12.80	3400 (200 ~ 3840)	14.9	15.6 - 14.3	3.76
(1.8 + 1.8) + (1.8 + 3.5)	8.9	(1.80 + 1.80) + (1.80 + 3.50) (1.5-9.6)	8.90	2680 (200 ~ 2960)	11.8	12.3 - 11.3	3.32	(2.50 + 2.50) + (2.33 + 4.47) (1.5-12.4)	11.80	3140 (200 ~ 3560)	13.8	14.4 - 13.2	3.76
(1.8 + 2.5) + (1.8 + 3.5)	9.6	(1.80 + 2.50) + (1.80 + 3.50) (1.5-10.2)	9.60	2880 (200 ~ 3110)	12.6	13.2 - 12.1	3.33	(2.50 + 3.90) + (2.33 + 4.47) (1.5-13.5)	13.20	3550 (200 ~ 3930)	15.6	16.3 - 14.9	3.72
(1.8 + 1.8) + (1.8 + 5.0)	10.4	(1.80 + 1.80) + (1.40 + 3.90) (1.5-9.9)	8.90	2680 (200 ~ 2960)	11.8	12.3 - 11.3	3.32	(2.50 + 2.50) + (1.80 + 5.00) (1.5-12.4)	11.80	3110 (200 ~ 3560)	13.7	14.3 - 13.1	3.79
(1.8 + 2.5) + (1.8 + 5.0)	11.1	(1.80 + 2.50) + (1.40 + 3.90) (1.5-10.5)	9.60	2880 (200 ~ 3110)	12.6	13.2 - 12.1	3.33	(2.50 + 3.90) + (1.80 + 5.00) (1.5-13.5)	13.20	3520 (200 ~ 3930)	15.5	16.2 - 14.8	3.75
(1.8 + 3.5) + (1.8 + 3.5)	10.6	(1.80 + 3.50) + (1.80 + 3.50) (1.5-11.2)	10.60	3200 (200 ~ 3320)	14.1	14.7 - 13.5	3.31	(2.33 + 4.47) + (2.33 + 4.47) (1.5-14.4)	13.60	3700 (200 ~ 4020)	16.2	17.0 - 15.6	3.68
(1.8 + 3.5) + (1.8 + 5.0)	12.1	(1.80 + 3.50) + (1.40 + 3.90) (1.5-11.5)	10.60	3200 (200 ~ 3320)	14.1	14.7 - 13.5	3.31	(2.33 + 4.47) + (1.80 + 5.00) (1.5-14.4)	13.60	3670 (200 ~ 4020)	16.1	16.9 - 15.4	3.71
(1.8 + 5.0) + (1.8 + 5.0)	13.6	(1.40 + 3.90) + (1.40 + 3.90) (1.5-11.8)	10.60	3200 (200 ~ 3320)	14.1	14.7 - 13.5	3.31	(1.80 + 5.00) + (1.80 + 5.00) (1.5-14.4)	13.60	3640 (200 ~ 4020)	16.0	16.7 - 15.3	3.74
(1.8 + 2.5) + (2.5 + 2.5)	9.3	(1.80 + 2.50) + (2.50 + 2.50) (1.5-10.2)	9.30	2750 (200 ~ 3110)	12.1	12.6 - 11.6	3.38	(2.50 + 3.90) + (3.40 + 3.40) (1.5-13.5)	13.20	3520 (200 ~ 3930)	15.5	16.2 - 14.8	3.75
(1.8 + 5.0) + (2.5 + 2.5)	11.8	(1.40 + 3.90) + (2.50 + 2.50) (1.5-11.5)	9.30	3070 (200 ~ 3320)	13.5	14.1 - 12.9	3.36	(1.80 + 5.00) + (3.40 + 3.40) (1.5-14.4)	13.60	3640 (200 ~ 4020)	16.0	16.7 - 15.3	3.74
(1.8 + 3.5) + (2.5 + 2.5)	10.3	(1.80 + 3.50) + (2.50 + 2.50) (1.5-11.2)	10.30	3070 (200 ~ 3320)	13.5	14.1 - 12.9	3.36	(2.33 + 4.47) + (3.40 + 3.40) (1.5-14.4)	13.60	3670 (200 ~ 4020)	16.1	16.9 - 15.4	3.71
(1.8 + 3.5) + (2.5 + 3.5)	11.3	(1.80 + 3.50) + (2.21 + 3.09) (1.5-11.3)	10.60	3200 (200 ~ 3320)	14.1	14.7 - 13.5	3.31	(2.33 + 4.47) + (2.83 + 3.97) (1.5-14.4)	13.60	3670 (200 ~ 4020)	16.1	16.9 - 15.4	3.71
(1.8 + 5.0) + (2.5 + 3.5)	12.8	(1.40 + 3.90) + (2.21 + 3.09) (1.5-11.8)	10.60	3200 (200 ~ 3320)	14.1	14.7 - 13.5	3.31	(1.80 + 5.00) + (2.83 + 3.97) (1.5-14.4)	13.60	3640 (200 ~ 4020)	16.0	16.7 - 15.3	3.74
(1.8 + 5.0) + (2.5 + 5.0)	14.3	(1.40 + 3.90) + (1.77 + 3.53) (1.5-11.8)	10.60	3200 (200 ~ 3320)	14.1	14.7 - 13.5	3.31	(1.80 + 5.00) + (2.55 + 4.25) (1.5-14.4)	13.60	3610 (200 ~ 4020)	15.9	16.6 - 15.2	3.77
(1.8 + 3.5) + (3.5 + 3.5)	12.3	(1.80 + 3.50) + (2.65 + 2.65) (1.5-11.5)	10.60	3200 (200 ~ 3320)	14.1	14.7 - 13.5	3.31	(2.33 + 4.47) + (3.40 + 3.40) (1.5-14.4)	13.60	3640 (200 ~ 4020)	16.0	16.7 - 15.3	3.74
(1.8 + 5.0) + (3.5 + 3.5)	13.8	(1.40 + 3.90) + (2.65 + 2.65) (1.5-11.8)	10.60	3200 (200 ~ 3320)	14.1	14.7 - 13.5	3.31	(1.80 + 5.00) + (3.40 + 3.40) (1.5-14.4)	13.60	3610 (200 ~ 4020)	15.9	16.6 - 15.2	3.77
(1.8 + 5.0) + (3.5 + 5.0)	15.3	(1.40 + 3.90) + (2.18 + 3.12) (1.5-12.5)	10.60	3200 (200 ~ 3320)	14.1	14.7 - 13.5	3.31	(1.80 + 5.00) + (2.89 + 3.91) (1.5-14.4)	13.60	3610 (200 ~ 4020)	15.9	16.6 - 15.2	3.77
(2.5 + 2.5) + (2.5 + 2.5)	10.0	(2.50 + 2.50) + (2.50 + 2.50) (1.5-11.2)	10.00	2940 (200 ~ 3320)	12.9	13.5 - 12.4	3.40	(3.40 + 3.40) + (3.40 + 3.40) (1.5-14.4)	13.60	3640 (200 ~ 4020)	16.0	16.7 - 15.3	3.74
(2.5 + 2.5) + (2.5 + 3.5)	11.0	(2.50 + 2.50) + (2.21 + 3.09) (1.5-11.3)	10.30	3070 (200 ~ 3320)	13.5	14.1 - 12.9	3.36	(3.40 + 3.40) + (2.83 + 3.97) (1.5-14.4)	13.60	3640 (200 ~ 4020)	16.0	16.7 - 15.3	3.74
(2.5 + 2.5) + (2.5 + 5.0)	12.5	(2.50 + 2.50) + (1.77 + 3.53) (1.5-11.5)	10.30	3070 (200 ~ 3320)	13.5	14.1 - 12.9	3.36	(3.40 + 3.40) + (2.55 + 4.25) (1.5-14.4)	13.60	3610 (200 ~ 4020)	15.9	16.6 - 15.2	3.77
(2.5 + 3.5) + (2.5 + 3.5)	12.0	(2.21 + 3.09) + (2.21 + 3.09) (1.5-11.4)	10.60	3200 (200 ~ 3320)	14.1	14.7 - 13.5	3.31	(2.83 + 3.97) + (2.83 + 3.97) (1.5-14.4)	13.60	3640 (200 ~ 4020)	16.0	16.7-15.3	3.74
(2.5 + 5.0) + (2.5 + 3.5)	13.5	(1.77 + 3.53) + (2.21 + 3.09) (1.5-11.8)	10.60	3200 (200 ~ 3320)	14.1	14.7 - 13.5	3.31	(2.55 + 4.25) + (2.83 + 3.97) (1.5-14.4)	13.60	3610 (200 ~ 4020)	15.9	16.6-15.2	3.77
(2.5 + 5.0) + (2.5+5.0)	15.0	(1.77 + 3.53) + (1.77 + 3.53) (1.5-11.8)	10.60	3200 (200 ~ 3320)	14.1	14.7 - 13.5	3.31	(2.55 + 4.25) + (2.55 + 4.25) (1.5-14.4)	13.60	3580 (200 ~ 4020)	15.7	16.4-15.1	3.80
(2.5 + 3.5) + (3.5 + 3.5)	13.0	(2.21 + 3.09) + (2.65 + 2.65) (1.5-11.6)	10.60	3200 (200 ~ 3320)	14.1	14.7-13.5	3.31	(2.83 + 3.97) + (3.40 + 3.40) (1.5-14.4)	13.60	3610 (200 ~ 4020)	15.9	16.6-15.2	3.77
(2.5 + 5.0) + (3.5 + 3.5)	14.5	(1.77 + 3.53) + (2.65 + 2.65) (1.5-11.8)	10.60	3200 (200 ~ 3320)	14.1	14.7-13.5	3.31	(2.55 + 4.25) + (3.40 + 3.40) (1.5-14.4)	13.60	3580 (200 ~ 4020)	15.7	16.4-15.1	3.80
(3.5 + 3.5) + (3.5 + 3.5)	14.0	(2.65 + 2.65) + (2.65 + 2.65) (1.5-11.8)	10.60	3200 (200 ~ 3320)	14.1	14.7-13.5	3.31	(3.40 + 3.40) + (3.40 + 3.40) (1.5-14.4)	13.60	3580 (200 ~ 4020)	15.7	16.4-15.1	3.80
(3.5 + 3.5) + (3.5 + 5.0)	15.5	(2.65 + 2.65) + (2.18 + 3.12) (1.5-12.5)	10.60	3200 (200 ~ 3320)	14.1	14.7-13.5	3.31	(3.40 + 3.40) + (2.89 + 3.91) (1.5-14.4)	13.60	3580 (200 ~ 4020)	15.7	16.4-15.1	3.80
(3.5 + 5.0) + (3.5 + 5.0)	17.0	(2.18 + 3.12) + (2.18 + 3.12) (1.5-13.2)	10.60	3200 (200 ~ 3320)	14.1	14.7-13.5	3.31	(2.89 + 3.91) + (2.89 + 3.91) (1.5-14.4)	13.60	3580 (200 ~ 4020)	15.7	16.4-15.1	3.80
(1.5 + 1.5) + (1.5 + 1.5 + 1.5)	7.5	(1.50 + 1.50) + (1.50 + 1.50 + 1.50) (1.5-8.9)	7.50	2290 (200 ~ 2680)	10.1	10.5-9.6	3.28	(2.00 + 2.00) + (2.00 + 2.00 + 2.00) (1.5-10.9)	10.00	2740 (200 ~ 2930)	12.0	12.6-11.5	3.65
(1.5 + 1.5) + (1.5 + 1.5 + 1.8)	7.8	(1.50 + 1.50) + (1.50 + 1.50 + 1.80) (1.5-9.1)	7.80	2390 (200 ~ 2680)	10.5	11.0-10.1	3.26	(2.00 + 2.00) + (2.00 + 2.00 + 2.50) (1.5-11.3)	10.50	2800 (200 ~ 3140)	12.3	12.9-11.8	3.75
(1.5 + 1.5) + (1.5 + 1.5 + 2.5)	8.5	(1.50 + 1.50) + (1.45 + 1.45 + 2.41)<											

(1.5 + 3.5) + (1.8 + 3.5 + 3.5)	13.8	(1.50 + 3.50) + (1.08 + 2.11 + 2.11) (1.5-12.5)	10.30	3080 (200 - 3340)	13.5	14.1 - 13.0	3.34	(2.00 + 4.80) + (1.40 + 2.70 + 2.70) (1.5-14.4)	13.60	3620 (200 - 3870)	15.9	16.6 - 15.2	3.76
(1.5 + 3.5) + (2.5 + 2.5 + 2.5)	12.5	(1.50 + 3.50) + (1.77 + 1.77 + 1.77) (1.5-12.5)	10.30	3080 (200 - 3340)	13.5	14.1 - 13.0	3.34	(2.00 + 4.80) + (2.27 + 2.27 + 2.27) (1.5-14.4)	13.60	3620 (200 - 3870)	15.9	16.6 - 15.2	3.76
(1.5 + 3.5) + (2.5 + 2.5 + 3.5)	13.5	(1.50 + 3.50) + (1.56 + 1.56 + 2.18) (1.5-10.9)	10.30	3080 (200 - 3340)	13.5	14.1 - 13.0	3.34	(2.00 + 4.80) + (2.00 + 2.00 + 2.80) (1.5-14.4)	13.60	3620 (200 - 3870)	15.9	16.6 - 15.2	3.76
(1.5 + 5.0) + (1.5 + 1.5 + 1.5)	11.0	(1.22 + 4.08) + (1.50 + 1.50 + 1.50) (1.5-10.9)	9.80	2970 (200 - 3340)	13.0	13.6 - 12.5	3.30	(1.60 + 5.20) + (2.00 + 2.00 + 2.00) (1.5-13.4)	12.80	3500 (200 - 3560)	15.4	16.1 - 14.7	3.66
(1.5 + 5.0) + (1.5 + 1.5 + 1.8)	11.3	(1.22 + 4.08) + (1.50 + 1.50 + 1.80) (1.5-11.9)	10.10	3070 (200 - 3340)	13.5	14.1 - 12.9	3.29	(1.60 + 5.20) + (2.00 + 2.00 + 2.50) (1.5-13.8)	13.30	3560 (200 - 3770)	15.6	16.3 - 15.0	3.74
(1.5 + 5.0) + (1.5 + 1.5 + 2.5)	12.0	(1.22 + 4.08) + (1.45 + 1.45 + 2.41) (1.5-11.9)	10.60	3200 (200 - 3320)	14.1	14.7 - 13.5	3.31	(1.60 + 5.20) + (1.72 + 1.72 + 3.36) (1.5-14.4)	13.60	3620 (200 - 3870)	15.9	16.6 - 15.2	3.76
(1.5 + 5.0) + (1.5 + 1.5 + 3.5)	13.0	(1.22 + 4.08) + (1.22 + 1.22 + 2.85) (1.5-11.9)	10.60	3200 (200 - 3340)	14.1	14.7 - 13.5	3.31	(1.60 + 5.20) + (1.55 + 1.55 + 3.71) (1.5-14.4)	13.60	3620 (200 - 3870)	15.9	16.6 - 15.2	3.76
(1.5 + 5.0) + (1.5 + 1.5 + 5.0)	14.5	(1.22 + 4.08) + (0.99 + 0.99 + 3.31) (1.5-11.9)	10.60	3200 (200 - 3340)	14.1	14.7 - 13.5	3.31	(1.60 + 5.20) + (1.30 + 1.30 + 4.21) (1.5-14.4)	13.60	3620 (200 - 3870)	15.9	16.6 - 15.2	3.76
(1.5 + 5.0) + (1.5 + 1.8 + 1.8)	11.6	(1.22 + 4.08) + (1.50 + 1.80 + 1.80) (1.5-11.9)	10.40	3150 (200 - 3320)	13.8	14.5 - 13.3	3.30	(1.60 + 5.20) + (1.94 + 2.43 + 2.43) (1.5-14.4)	13.60	3620 (200 - 3870)	15.9	16.6 - 15.2	3.76
(1.5 + 5.0) + (1.5 + 1.8 + 2.5)	12.3	(1.22 + 4.08) + (1.37 + 1.64 + 2.28) (1.5-11.9)	10.60	3200 (200 - 3340)	14.1	14.7 - 13.5	3.31	(1.60 + 5.20) + (1.62 + 2.02 + 3.16) (1.5-14.4)	13.60	3620 (200 - 3870)	15.9	16.6 - 15.2	3.76
(1.5 + 5.0) + (1.5 + 1.8 + 3.5)	13.3	(1.22 + 4.08) + (1.17 + 1.40 + 2.73) (1.5-11.9)	10.60	3200 (200 - 3340)	14.1	14.7 - 13.5	3.31	(1.60 + 5.20) + (1.46 + 1.83 + 3.51) (1.5-14.4)	13.60	3620 (200 - 3870)	15.9	16.6 - 15.2	3.76
(1.5 + 5.0) + (1.5 + 1.8 + 5.0)	14.8	(1.22 + 4.08) + (0.96 + 1.15 + 3.19) (1.5-11.9)	10.60	3200 (200 - 3340)	14.1	14.7 - 13.5	3.31	(1.60 + 5.20) + (1.24 + 1.55 + 4.02) (1.5-14.4)	13.60	3620 (200 - 3870)	15.9	16.6 - 15.2	3.76
(1.5 + 5.0) + (1.5 + 2.5 + 2.5)	13.0	(1.22 + 4.08) + (1.22 + 2.04 + 2.04) (1.5-11.9)	10.60	3200 (200 - 3340)	14.1	14.7 - 13.5	3.31	(1.60 + 5.20) + (1.39 + 2.71 + 2.71) (1.5-14.4)	13.60	3620 (200 - 3870)	15.9	16.6 - 15.2	3.76
(1.5 + 5.0) + (1.5 + 2.5 + 3.5)	14.0	(1.22 + 4.08) + (1.06 + 1.77 + 2.47) (1.5-11.9)	10.60	3200 (200 - 3340)	14.1	14.7 - 13.5	3.31	(1.60 + 5.20) + (1.27 + 2.48 + 3.05) (1.5-14.4)	13.60	3620 (200 - 3870)	15.9	16.6 - 15.2	3.76
(1.5 + 5.0) + (1.5 + 3.5 + 3.5)	15.0	(1.22 + 4.08) + (0.94 + 2.18 + 2.18) (1.5-11.9)	10.60	3200 (200 - 3340)	14.1	14.7 - 13.5	3.31	(1.60 + 5.20) + (1.17 + 2.81 + 2.81) (1.5-14.4)	13.60	3620 (200 - 3870)	15.9	16.6 - 15.2	3.76
(1.5 + 5.0) + (1.8 + 1.8 + 1.8)	11.9	(1.22 + 4.08) + (1.77 + 1.77 + 1.77) (1.5-11.9)	10.60	3200 (200 - 3340)	14.1	14.7 - 13.5	3.31	(1.60 + 5.20) + (2.27 + 2.27 + 2.27) (1.5-14.4)	13.60	3620 (200 - 3870)	15.9	16.6 - 15.2	3.76
(1.5 + 5.0) + (1.8 + 1.8 + 2.5)	12.6	(1.22 + 4.08) + (1.56 + 1.56 + 2.17) (1.5-12.3)	10.60	3200 (200 - 3340)	14.1	14.7 - 13.5	3.31	(1.60 + 5.20) + (1.81 + 1.91 + 2.98) (1.5-14.4)	13.60	3620 (200 - 3870)	15.9	16.6 - 15.2	3.76
(1.5 + 5.0) + (1.8 + 1.8 + 3.5)	13.6	(1.22 + 4.08) + (1.34 + 1.34 + 2.61) (1.5-12.5)	10.60	3200 (200 - 3340)	14.1	14.7 - 13.5	3.31	(1.60 + 5.20) + (1.73 + 1.73 + 3.33) (1.5-14.4)	13.60	3620 (200 - 3870)	15.9	16.6 - 15.2	3.76
(1.5 + 5.0) + (1.8 + 1.8 + 5.0)	15.1	(1.22 + 4.08) + (1.11 + 1.11 + 3.08) (1.5-12.5)	10.60	3200 (200 - 3340)	14.1	14.7 - 13.5	3.31	(1.60 + 5.20) + (1.48 + 1.48 + 3.84) (1.5-14.4)	13.60	3620 (200 - 3870)	15.9	16.6 - 15.2	3.76
(1.5 + 5.0) + (1.8 + 2.5 + 2.5)	13.3	(1.22 + 4.08) + (1.40 + 1.95 + 1.95) (1.5-12.5)	10.60	3200 (200 - 3340)	14.1	14.7 - 13.5	3.31	(1.60 + 5.20) + (1.65 + 2.57 + 2.57) (1.5-14.4)	13.60	3620 (200 - 3870)	15.9	16.6 - 15.2	3.76
(1.5 + 5.0) + (1.8 + 2.5 + 3.5)	14.3	(1.22 + 4.08) + (1.22 + 1.70 + 2.38) (1.5-12.5)	10.60	3200 (200 - 3340)	14.1	14.7 - 13.5	3.31	(1.60 + 5.20) + (1.52 + 2.37 + 2.91) (1.5-14.4)	13.60	3620 (200 - 3870)	15.9	16.6 - 15.2	3.76
(1.5 + 5.0) + (1.8 + 3.5 + 3.5)	15.3	(1.22 + 4.08) + (1.08 + 2.11 + 2.11) (1.5-12.5)	10.60	3200 (200 - 3340)	14.1	14.7 - 13.5	3.31	(1.60 + 5.20) + (1.40 + 2.70 + 2.70) (1.5-14.4)	13.60	3620 (200 - 3870)	15.9	16.6 - 15.2	3.76
(1.5 + 5.0) + (2.5 + 2.5 + 2.5)	14.0	(1.22 + 4.08) + (1.77 + 1.77 + 1.77) (1.5-12.5)	10.60	3200 (200 - 3340)	14.1	14.7 - 13.5	3.31	(1.60 + 5.20) + (2.27 + 2.27 + 2.27) (1.5-14.4)	13.60	3620 (200 - 3870)	15.9	16.6 - 15.2	3.76
(1.5 + 5.0) + (2.5 + 2.5 + 3.5)	15.0	(1.22 + 4.08) + (1.56 + 1.56 + 2.18) (1.5-12.5)	10.60	3200 (200 - 3340)	14.1	14.7 - 13.5	3.31	(1.60 + 5.20) + (2.00 + 2.00 + 2.80) (1.5-14.4)	13.60	3620 (200 - 3870)	15.9	16.6 - 15.2	3.76
(1.8 + 1.8) + (1.8 + 1.8 + 1.8)	9	(1.80 + 1.80) + (1.77 + 1.77 + 1.77) (1.5-10)	8.90	2680 (200 - 2980)	11.8	12.3 - 11.3	3.32	(2.50 + 2.50) + (2.27 + 2.27 + 2.27) (1.5-12.4)	11.80	3090 (200 - 3410)	13.6	14.2 - 13.0	3.82
(1.8 + 1.8) + (1.8 + 1.8 + 2.5)	9.7	(1.80 + 1.80) + (1.56 + 1.56 + 2.17) (1.5-10.9)	8.90	2680 (200 - 2980)	11.8	12.3 - 11.3	3.32	(2.50 + 2.50) + (1.81 + 1.91 + 2.98) (1.5-12.4)	11.80	3090 (200 - 3410)	13.6	14.2 - 13.0	3.82
(1.8 + 3.5) + (1.8 + 1.8 + 1.8)	10.7	(1.80 + 3.50) + (1.77 + 1.77 + 1.77) (1.5-11.6)	10.60	3200 (200 - 3340)	14.1	14.7 - 13.5	3.31	(2.33 + 4.47) + (2.27 + 2.27 + 2.27) (1.5-14.4)	13.60	3650 (200 - 3870)	16.0	16.8 - 15.4	3.73
(1.8 + 5.0) + (1.8 + 1.8 + 1.8)	12.2	(1.40 + 3.90) + (1.77 + 1.77 + 1.77) (1.5-11.9)	10.60	3200 (200 - 3340)	14.1	14.7 - 13.5	3.31	(1.80 + 5.00) + (2.27 + 2.27 + 2.27) (1.5-14.4)	13.60	3620 (200 - 3870)	15.9	16.6 - 15.2	3.76
(1.8 + 2.5) + (1.8 + 1.8 + 2.5)	10.4	(1.80 + 2.50) + (1.56 + 1.56 + 2.17) (1.5-11)	9.60	2880 (200 - 3130)	12.6	13.2 - 12.1	3.33	(2.50 + 3.90) + (1.91 + 1.91 + 2.98) (1.5-13.5)	13.20	3500 (200 - 3780)	15.4	16.1 - 14.7	3.77
(1.8 + 3.5) + (1.8 + 1.8 + 2.5)	11.4	(1.80 + 3.50) + (1.56 + 1.56 + 2.17) (1.5-12)	10.60	3200 (200 - 3340)	14.1	14.7 - 13.5	3.31	(2.33 + 4.47) + (1.91 + 1.91 + 2.98) (1.5-14.4)	13.60	3650 (200 - 3870)	16.0	16.8 - 15.4	3.73
(1.8 + 5.0) + (1.8 + 1.8 + 2.5)	12.9	(1.40 + 3.90) + (1.56 + 1.56 + 2.17) (1.5-12.3)	10.60	3200 (200 - 3340)	14.1	14.7 - 13.5	3.31	(1.80 + 5.00) + (1.91 + 1.91 + 2.98) (1.5-14.4)	13.60	3620 (200 - 3870)	15.9	16.6 - 15.2	3.76
(1.8 + 3.5) + (1.8 + 1.8 + 3.5)	12.4	(1.80 + 3.50) + (1.34 + 1.34 + 2.61) (1.5-12.2)	10.60	3200 (200 - 3340)	14.1	14.7 - 13.5	3.31	(2.33 + 4.47) + (1.73 + 1.73 + 3.33) (1.5-14.4)	13.60	3650 (200 - 3870)	16.0	16.8 - 15.4	3.73
(1.8 + 5.0) + (1.8 + 1.8 + 3.5)	13.9	(1.40 + 3.90) + (1.34 + 1.34 + 2.61) (1.5-12.5)	10.60	3200 (200 - 3340)	14.1	14.7 - 13.5	3.31	(1.80 + 5.00) + (1.73 + 1.73 + 3.33) (1.5-14.4)	13.60	3620 (200 - 3870)	15.9	16.6 - 15.2	3.76
(1.8 + 5.0) + (1.8 + 1.8 + 5.0)	15.4	(1.40 + 3.90) + (1.11 + 1.11 + 3.08) (1.5-12.5)	10.60	3200 (200 - 3340)	14.1	14.7 - 13.5	3.31	(1.80 + 5.00) + (1.48 + 1.48 + 3.84) (1.5-14.4)	13.60	3620 (200 - 3870)	15.9	16.6 - 15.2	3.76
(2.5 + 2.5) + (1.8 + 1.8 + 2.5)	11.1	(2.50 + 2.50) + (1.56 + 1.56 + 2.17) (1.5-12)	10.30	3070 (200 - 3340)	13.5	14.1 - 12.9	3.36	(3.40 + 3.40) + (1.91 + 1.91 + 2.98) (1.5-14.4)	13.60	3620 (200 - 3870)	15.9	16.6 - 15.2	3.76
(2.5 + 3.5) + (1.8 + 1.8 + 2.5)	12.1	(2.21 + 3.09) + (1.56 + 1.56 + 2.17) (1.5-12.1)	10.60	3200 (200 - 3340)	14.1	14.7 - 13.5	3.31	(2.83 + 3.97) + (1.91 + 1.91 + 2.98) (1.5-14.4)	13.60	3620 (200 - 3870)	15.9	16.6 - 15.2	3.76
(1.8 + 5.0) + (1.8 + 2.5 + 2.5)	13.6	(1.40 + 3.90) + (1.40 + 1.95 + 1.95) (1.5-12.5)	10.60	3200 (200 - 3340)	14.1	14.7 - 13.5	3.31	(1.80 + 5.00) + (1.65 + 2.57 + 2.57) (1.5-14.4)	13.60	3620 (200 - 3870)	15.9	16.6 - 15.2	3.76
(3.5 + 3.5) + (1.8 + 1.8 + 2.5)	13.1	(2.65 + 2.65) + (1.56 + 1.56 + 2.17) (1.5-12.3)	10.60	3200 (200 - 3340)	14.1	14.7 - 13.5	3.31	(3.40 + 3.40) + (1.91 + 1.91 + 2.98) (1.5-14.4)	13.60	3590 (200 - 3870)	15.8	16.5 - 15.1	3.79
(1.8 + 5.0) + (1.8 + 2.5 + 3.5)	14.6	(1.40 + 3.90) + (1.22 + 1.70 + 2.38) (1.5-12.5)	10.60	3200 (200 - 3340)	14.1	14.7 - 13.5	3.31	(1.80 + 5.00) + (1.52 + 2.37 + 2.91) (1.5-14.4)	13.60	3620 (200 - 3870)	15.9	16.6 - 15.2	3.76
(3.5 + 3.5) + (1.8 + 1.8 + 3.5)	14.1	(2.65 + 2.65) + (1.34 + 1.34 + 2.61) (1.5-12.5)	10.60	3200 (200 - 3340)	14.1	14.7 - 13.5	3.31	(3.40 + 3.40) + (1.73 + 1.73 + 3.33) (1.5-14.4)	13.60	3590 (200 - 3870)	15.8	16.5 - 15.1	3.79
(2.5 + 2.5) + (1.8 + 2.5 + 2.5)	11.8	(2.50 + 2.50) + (1.40 + 1.95 + 1.95) (1.5-12.2)	10.30	3070 (200 - 3340)	13.5	14.1 - 12.9	3.36	(3.40 + 3.40) + (1.65 + 2.57 + 2.57) (1.5-14.4)	13.60	3620 (200 - 3870)	15.9	16.6 - 15.2	3.76
(2.5 + 3.5) + (1.8 + 2.5 + 2.5)	12.8	(2.21 + 3.09) + (1.40 + 1.95 + 1.95) (1.5-12.3)	10.60	3200 (200 - 3340)	14.1	14.7 - 13.5	3.31	(2.83 + 3.97) + (1.65 + 2.57 + 2.57) (1.5-14.4)	13.60	3620 (200 - 3870)	15.9	16.6 - 15.2	3.76
(1.8 + 5.0) + (2.5 + 2.5 + 2.5)	14.3	(1.40 + 3.90) + (1.77 + 1.77 + 1.77) (1.5-13.5)	10.60	3200 (200 - 3340)	14.1	14.7 - 13.5	3.31	(1.80 + 5.00) + (2.27 + 2.27 + 2.27) (1.5-14.4)	13.60	3620 (200 - 3870)	15.9	16.6 - 15.2	3.76
(3.5 + 3.5) + (1.8 + 2.5 + 2.5)	13.8	(2.65 + 2.65) + (1.40 + 1.95 + 1.95) (1.5-12.5)	10.60	3200 (200 - 3340)	14.1	14.7 - 13.5	3.31	(3.40 + 3.40) + (1.65 + 2.57 + 2.57) (1.5-14.4)	13.60	3590 (200 - 3870)	15.8	16.5 - 15.1	3.79
(2.5 + 5.0) + (1.8 + 2.5 + 3.5)	15.3	(1.77 + 3.53) + (1.22 + 1.70 + 2.38) (1.5-12.5											

(1.5+1.5+1.5)+(1.5+2.5+2.5)	11	(1.50+1.50+1.50)+(1.22+2.04+2.04) (1.5-11)	9.80	2970 (200-3360)	13.0	13.6-12.5	3.30	(2.00+2.00+2.00)+(1.39+2.71+2.71) (1.5-13.4)	12.80	3480 (200-3410)	15.3	16.0-14.6	3.68
(1.5+1.5+1.5)+(1.5+2.5+3.5)	12	(1.50+1.50+1.50)+(1.06+1.77+2.47) (1.5-11)	9.80	2970 (200-3360)	13.0	13.6-12.5	3.30	(2.00+2.00+2.00)+(1.27+2.48+3.05) (1.5-13.4)	12.80	3480 (200-3410)	15.3	16.0-14.6	3.68
(1.5+1.5+1.5)+(1.5+3.5+3.5)	13	(1.50+1.50+1.50)+(0.94+2.18+2.18) (1.5-11)	9.80	2970 (200-3360)	13.0	13.6-12.5	3.30	(2.00+2.00+2.00)+(1.17+2.81+2.81) (1.5-13.4)	12.80	3480 (200-3410)	15.3	16.0-14.6	3.68
(1.5+1.5+1.5)+(1.8+1.8+1.8)	9.9	(1.50+1.50+1.50)+(1.77+1.77+1.77) (1.5-11)	9.80	2970 (200-3360)	13.0	13.6-12.5	3.30	(2.00+2.00+2.00)+(2.27+2.27+2.27) (1.5-13.4)	12.80	3480 (200-3410)	15.3	16.0-14.6	3.68
(1.5+1.5+1.5)+(1.8+1.8+2.5)	10.6	(1.50+1.50+1.50)+(1.56+1.56+2.17) (1.5-11.4)	9.80	2970 (200-3360)	13.0	13.6-12.5	3.30	(2.00+2.00+2.00)+(1.91+1.91+2.98) (1.5-13.4)	12.80	3480 (200-3410)	15.3	16.0-14.6	3.68
(1.5+1.5+1.5)+(1.8+1.8+3.5)	11.6	(1.50+1.50+1.50)+(1.34+1.34+2.61) (1.5-11.6)	9.80	2970 (200-3360)	13.0	13.6-12.5	3.30	(2.00+2.00+2.00)+(1.73+1.73+3.33) (1.5-13.4)	12.80	3480 (200-3410)	15.3	16.0-14.6	3.68
(1.5+1.5+1.5)+(1.8+1.8+5.0)	13.1	(1.50+1.50+1.50)+(1.11+1.11+3.08) (1.5-11.6)	9.80	2970 (200-3360)	13.0	13.6-12.5	3.30	(2.00+2.00+2.00)+(1.48+1.48+3.84) (1.5-13.4)	12.80	3480 (200-3410)	15.3	16.0-14.6	3.68
(1.5+1.5+1.5)+(1.8+2.5+2.5)	11.3	(1.50+1.50+1.50)+(1.40+1.95+1.95) (1.5-11.6)	9.80	2970 (200-3360)	13.0	13.6-12.5	3.30	(2.00+2.00+2.00)+(1.65+2.57+2.57) (1.5-13.4)	12.80	3480 (200-3410)	15.3	16.0-14.6	3.68
(1.5+1.5+1.5)+(1.8+2.5+3.5)	12.3	(1.50+1.50+1.50)+(1.22+1.70+2.38) (1.5-11.6)	9.80	2970 (200-3360)	13.0	13.6-12.5	3.30	(2.00+2.00+2.00)+(1.52+2.37+2.91) (1.5-13.4)	12.80	3480 (200-3410)	15.3	16.0-14.6	3.68
(1.5+1.5+1.5)+(1.8+3.5+3.5)	13.3	(1.50+1.50+1.50)+(1.08+2.11+2.11) (1.5-11.6)	9.80	2970 (200-3360)	13.0	13.6-12.5	3.30	(2.00+2.00+2.00)+(1.40+2.70+2.70) (1.5-13.4)	12.80	3480 (200-3410)	15.3	16.0-14.6	3.68
(1.5+1.5+1.5)+(2.5+2.5+2.5)	12	(1.50+1.50+1.50)+(1.77+1.77+1.77) (1.5-11.6)	9.80	2970 (200-3360)	13.0	13.6-12.5	3.30	(2.00+2.00+2.00)+(2.27+2.27+2.27) (1.5-13.4)	12.80	3480 (200-3410)	15.3	16.0-14.6	3.68
(1.5+1.5+1.5)+(2.5+2.5+3.5)	13	(1.50+1.50+1.50)+(1.56+1.56+2.18) (1.5-11.6)	9.80	2970 (200-3360)	13.0	13.6-12.5	3.30	(2.00+2.00+2.00)+(2.00+2.00+2.80) (1.5-13.4)	12.80	3480 (200-3410)	15.3	16.0-14.6	3.68
(1.5+1.5+1.8)+(1.5+1.5+1.5)	9.3	(1.50+1.50+1.80)+(1.50+1.50+1.50) (1.5-11)	9.30	2840 (200-3360)	12.5	13.0-12.0	3.27	(2.00+2.00+2.50)+(2.00+2.00+2.00) (1.5-12.8)	12.50	3420 (200-3310)	15.0	15.7-14.4	3.65
(1.5+1.5+1.8)+(1.5+1.5+1.8)	9.6	(1.50+1.50+1.80)+(1.50+1.50+1.80) (1.5-12)	9.60	2940 (200-3360)	12.9	13.5-12.4	3.27	(2.00+2.00+2.50)+(2.00+2.00+2.50) (1.5-13.2)	13.00	3480 (200-3520)	15.3	16.0-14.6	3.74
(1.5+1.5+1.8)+(1.5+1.5+2.5)	10.3	(1.50+1.50+1.80)+(1.45+1.45+2.41) (1.5-12)	10.10	3070 (200-3340)	13.5	14.1-12.9	3.29	(2.00+2.00+2.50)+(1.72+1.72+3.36) (1.5-13.8)	13.30	3540 (200-3620)	15.5	16.3-14.9	3.76
(1.5+1.5+1.8)+(1.5+1.5+3.5)	11.3	(1.50+1.50+1.80)+(1.22+1.22+2.85) (1.5-12)	10.10	3070 (200-3360)	13.5	14.1-12.9	3.29	(2.00+2.00+2.50)+(1.55+1.55+3.71) (1.5-13.8)	13.30	3540 (200-3620)	15.5	16.3-14.9	3.76
(1.5+1.5+1.8)+(1.5+1.5+5.0)	12.8	(1.50+1.50+1.80)+(0.99+0.99+3.31) (1.5-12)	10.10	3070 (200-3360)	13.5	14.1-12.9	3.29	(2.00+2.00+2.50)+(1.30+1.30+4.21) (1.5-13.8)	13.30	3540 (200-3620)	15.5	16.3-14.9	3.76
(1.5+1.5+1.8)+(1.5+1.8+1.8)	9.9	(1.50+1.50+1.80)+(1.50+1.80+1.80) (1.5-12)	9.90	3020 (200-3340)	13.3	13.9-12.7	3.28	(2.00+2.00+2.50)+(1.94+2.43+2.43) (1.5-13.8)	13.30	3540 (200-3620)	15.5	16.3-14.9	3.76
(1.5+1.5+1.8)+(1.5+1.8+2.5)	10.6	(1.50+1.50+1.80)+(1.37+1.64+2.28) (1.5-12)	10.10	3070 (200-3360)	13.5	14.1-12.9	3.29	(2.00+2.00+2.50)+(1.62+2.02+3.16) (1.5-13.8)	13.30	3540 (200-3620)	15.5	16.3-14.9	3.76
(1.5+1.5+1.8)+(1.5+1.8+3.5)	11.6	(1.50+1.50+1.80)+(1.17+1.40+2.73) (1.5-12)	10.10	3070 (200-3360)	13.5	14.1-12.9	3.29	(2.00+2.00+2.50)+(1.46+1.83+3.51) (1.5-13.8)	13.30	3540 (200-3620)	15.5	16.3-14.9	3.76
(1.5+1.5+1.8)+(1.5+1.8+5.0)	13.1	(1.50+1.50+1.80)+(0.96+1.15+3.19) (1.5-12)	10.10	3070 (200-3360)	13.5	14.1-12.9	3.29	(2.00+2.00+2.50)+(1.24+1.55+4.02) (1.5-13.8)	13.30	3540 (200-3620)	15.5	16.3-14.9	3.76
(1.5+1.5+1.8)+(1.5+2.5+2.5)	11.3	(1.50+1.50+1.80)+(1.22+2.04+2.04) (1.5-12)	10.10	3070 (200-3360)	13.5	14.1-12.9	3.29	(2.00+2.00+2.50)+(1.39+2.71+2.71) (1.5-13.8)	13.30	3540 (200-3620)	15.5	16.3-14.9	3.76
(1.5+1.5+1.8)+(1.5+2.5+3.5)	12.3	(1.50+1.50+1.80)+(1.06+1.77+2.47) (1.5-12)	10.10	3070 (200-3360)	13.5	14.1-12.9	3.29	(2.00+2.00+2.50)+(1.27+2.48+3.05) (1.5-13.8)	13.30	3540 (200-3620)	15.5	16.3-14.9	3.76
(1.5+1.5+1.8)+(1.5+3.5+3.5)	13.3	(1.50+1.50+1.80)+(0.94+2.18+2.18) (1.5-12)	10.10	3070 (200-3360)	13.5	14.1-12.9	3.29	(2.00+2.00+2.50)+(1.17+2.81+2.81) (1.5-13.8)	13.30	3540 (200-3620)	15.5	16.3-14.9	3.76
(1.5+1.5+1.8)+(1.8+1.8+1.8)	10.2	(1.50+1.50+1.80)+(1.77+1.77+1.77) (1.5-12)	10.10	3070 (200-3360)	13.5	14.1-12.9	3.29	(2.00+2.00+2.50)+(2.27+2.27+2.27) (1.5-13.8)	13.30	3540 (200-3620)	15.5	16.3-14.9	3.76
(1.5+1.5+1.8)+(1.8+1.8+2.5)	10.9	(1.50+1.50+1.80)+(1.56+1.56+2.17) (1.5-12.4)	10.10	3070 (200-3360)	13.5	14.1-12.9	3.29	(2.00+2.00+2.50)+(1.91+1.91+2.98) (1.5-13.8)	13.30	3540 (200-3620)	15.5	16.3-14.9	3.76
(1.5+1.5+1.8)+(1.8+1.8+3.5)	11.9	(1.50+1.50+1.80)+(1.34+1.34+2.61) (1.5-12.6)	10.10	3070 (200-3360)	13.5	14.1-12.9	3.29	(2.00+2.00+2.50)+(1.73+1.73+3.33) (1.5-13.8)	13.30	3540 (200-3620)	15.5	16.3-14.9	3.76
(1.5+1.5+1.8)+(1.8+1.8+5.0)	13.4	(1.50+1.50+1.80)+(1.11+1.11+3.08) (1.5-12.6)	10.10	3070 (200-3360)	13.5	14.1-12.9	3.29	(2.00+2.00+2.50)+(1.48+1.48+3.84) (1.5-13.8)	13.30	3540 (200-3620)	15.5	16.3-14.9	3.76
(1.5+1.5+1.8)+(1.8+2.5+2.5)	11.6	(1.50+1.50+1.80)+(1.40+1.95+1.95) (1.5-12.6)	10.10	3070 (200-3360)	13.5	14.1-12.9	3.29	(2.00+2.00+2.50)+(1.65+2.57+2.57) (1.5-13.8)	13.30	3540 (200-3620)	15.5	16.3-14.9	3.76
(1.5+1.5+1.8)+(1.8+2.5+3.5)	12.6	(1.50+1.50+1.80)+(1.22+1.70+2.38) (1.5-12.6)	10.10	3070 (200-3360)	13.5	14.1-12.9	3.29	(2.00+2.00+2.50)+(1.52+2.37+2.91) (1.5-13.8)	13.30	3540 (200-3620)	15.5	16.3-14.9	3.76
(1.5+1.5+1.8)+(1.8+3.5+3.5)	13.6	(1.50+1.50+1.80)+(1.08+2.11+2.11) (1.5-12.6)	10.10	3070 (200-3360)	13.5	14.1-12.9	3.29	(2.00+2.00+2.50)+(1.40+2.70+2.70) (1.5-13.8)	13.30	3540 (200-3620)	15.5	16.3-14.9	3.76
(1.5+1.5+1.8)+(2.5+2.5+2.5)	12.3	(1.50+1.50+1.80)+(1.77+1.77+1.77) (1.5-12.6)	10.10	3070 (200-3360)	13.5	14.1-12.9	3.29	(2.00+2.00+2.50)+(2.27+2.27+2.27) (1.5-13.8)	13.30	3540 (200-3620)	15.5	16.3-14.9	3.76
(1.5+1.5+1.8)+(2.5+2.5+3.5)	13.3	(1.50+1.50+1.80)+(1.56+1.56+2.18) (1.5-12.6)	10.10	3070 (200-3360)	13.5	14.1-12.9	3.29	(2.00+2.00+2.50)+(2.00+2.00+2.80) (1.5-13.8)	13.30	3540 (200-3620)	15.5	16.3-14.9	3.76
(1.5+1.5+2.5)+(1.5+1.5+1.5)	10	(1.45+1.45+2.41)+(1.50+1.50+1.50) (1.5-11)	9.80	2970 (200-3340)	13.0	13.6-12.5	3.30	(1.72+1.72+3.36)+(2.00+2.00+2.00) (1.5-13.4)	12.80	3480 (200-3410)	15.3	16.0-14.6	3.68
(1.5+1.5+2.5)+(1.5+1.5+1.8)	10.3	(1.45+1.45+2.41)+(1.50+1.50+1.80) (1.5-12)	10.10	3070 (200-3340)	13.5	14.1-12.9	3.29	(1.72+1.72+3.36)+(2.00+2.00+2.50) (1.5-13.8)	13.30	3540 (200-3620)	15.5	16.3-14.9	3.76
(1.5+1.5+2.5)+(1.5+1.5+2.5)	11	(1.45+1.45+2.41)+(1.45+1.45+2.41) (1.5-12)	10.60	3200 (200-3320)	14.1	14.7-13.5	3.31	(1.72+1.72+3.36)+(1.72+1.72+3.36) (1.5-14.4)	13.60	3600 (200-3720)	15.8	16.5-15.2	3.78
(1.5+1.5+2.5)+(1.5+1.5+3.5)	12	(1.45+1.45+2.41)+(1.22+1.22+2.85) (1.5-12)	10.60	3200 (200-3340)	14.1	14.7-13.5	3.31	(1.72+1.72+3.36)+(1.55+1.55+3.71) (1.5-14.4)	13.60	3600 (200-3720)	15.8	16.5-15.2	3.78
(1.5+1.5+2.5)+(1.5+1.5+5.0)	13.5	(1.45+1.45+2.41)+(0.99+0.99+3.31) (1.5-12)	10.60	3200 (200-3340)	14.1	14.7-13.5	3.31	(1.72+1.72+3.36)+(1.30+1.30+4.21) (1.5-14.4)	13.60	3600 (200-3720)	15.8	16.5-15.2	3.78
(1.5+1.5+2.5)+(1.5+1.8+1.8)	10.6	(1.45+1.45+2.41)+(1.50+1.80+1.80) (1.5-12)	10.40	3150 (200-3320)	13.8	14.5-13.3	3.30	(1.72+1.72+3.36)+(1.34+2.43+2.43) (1.5-14.4)	13.60	3600 (200-3720)	15.8	16.5-15.2	3.78
(1.5+1.5+2.5)+(1.5+1.8+2.5)	11.3	(1.45+1.45+2.41)+(1.37+1.64+2.28) (1.5-12)	10.60	3200 (200-3340)	14.1	14.7-13.5	3.31	(1.72+1.72+3.36)+(1.62+2.02+3.16) (1.5-14.4)	13.60	3600 (200-3720)	15.8	16.5-15.2	3.78
(1.5+1.5+2.5)+(1.5+1.8+3.5)	12.3	(1.45+1.45+2.41)+(1.17+1.40+2.73) (1.5-12)	10.60	3200 (200-3340)	14.1	14.7-13.5	3.31	(1.72+1.72+3.36)+(1.46+1.83+3.51) (1.5-14.4)	13.60	3600 (200-3720)	15.8	16.5-15.2	3.78
(1.5+1.5+2.5)+(1.5+1.8+5.0)	13.8	(1.45+1.45+2.41)+(0.96+1.15+3.19) (1.5-12)	10.60	3200 (200-3340)	14.1	14.7-13.5	3.31	(1.72+1.72+3.36)+(1.24+1.55+4.02) (1.5-14.4)	13.60	3600 (200-3720)	15.8	16.5-15.2	3.78
(1.5+1.5+2.5)+(1.5+2.5+2.5)	12	(1.45+1.45+2.41)+(1.22+2.04+2.04) (1.5-12)	10.60	3200 (200-3340)	14.1	14.7-13.5	3.31	(1.72+1.72+3.36)+(1.39+2.71+2.71) (1.5-14.4)	13.60	3600 (200-3720)	15.8	16.5-15.2	3.78
(1.5+1.5+2.5)+(1.5+2.5+3.5)	13	(1.45+1.45+2.41)+(1.06+1.77+2.47) (1.5-12)	10.60	3200 (200-3340)	14.1	14.7-13.5	3.31	(1.72+1.72+3.36)+(1.27+2.48+3.05) (1.5-14.4)	13.60	3600 (200-3720)	15.8	16.5-15.2	3.78
(1.5+1.5+2.5)+(1.5+3.5+3.5)	14	(1.45+1.45+2.41)+(0.94+2.18+2.18) (1.5-12)	10.60	3200 (200-3340)	14.1	14.7-13.5	3.31	(1.72+1.72+3.36)+(1.17+2.81+2.81) (1.5-14.4)	13.60	3600 (200-3720)	15.8	16.5-15.2	3.78
(1.5+1.5+2.5)+(1.8+1.8+1.8)	10.9	(1.45+1.45+2.41)+(1.77+1.77+1.77) (1.5-12)	10.60	3200 (200-3340									

(1.8 + 1.8 + 1.8) + (1.8 + 1.8 + 1.8)	10.8	(1.77 + 1.77 + 1.77) + (1.77 + 1.77 + 1.77) (1.5-12)	10.60	3200 (200 - 3360)	14.1	14.7-13.5	3.31	(2.27 + 2.27 + 2.27) + (2.27 + 2.27 + 2.27) (1.5-14.4)	13.60	3600 (200 - 3720)	15.8	16.5-15.2	3.78
(1.8 + 1.8 + 1.8) + (1.8 + 1.8 + 2.5)	11.5	(1.77 + 1.77 + 1.77) + (1.56 + 1.56 + 2.17) (1.5-12.4)	10.60	3200 (200 - 3360)	14.1	14.7-13.5	3.31	(2.27 + 2.27 + 2.27) + (1.91 + 1.91 + 2.98) (1.5-14.4)	13.60	3600 (200 - 3720)	15.8	16.5-15.2	3.78
(1.8 + 1.8 + 1.8) + (1.8 + 1.8 + 3.5)	12.5	(1.77 + 1.77 + 1.77) + (1.34 + 1.34 + 2.61) (1.5-12.6)	10.60	3200 (200 - 3360)	14.1	14.7-13.5	3.31	(2.27 + 2.27 + 2.27) + (1.73 + 1.73 + 3.33) (1.5-14.4)	13.60	3600 (200 - 3720)	15.8	16.5-15.2	3.78
(1.8 + 1.8 + 1.8) + (1.8 + 1.8 + 5.0)	14.0	(1.77 + 1.77 + 1.77) + (1.11 + 1.11 + 3.08) (1.5-12.8)	10.60	3200 (200 - 3360)	14.1	14.7-13.5	3.31	(2.27 + 2.27 + 2.27) + (1.48 + 1.48 + 3.84) (1.5-14.4)	13.60	3600 (200 - 3720)	15.8	16.5-15.2	3.78
(1.8 + 1.8 + 2.5) + (1.8 + 1.8 + 2.5)	12.2	(1.56 + 1.56 + 2.17) + (1.56 + 1.56 + 2.17) (1.5-13)	10.60	3200 (200 - 3360)	14.1	14.7-13.5	3.31	(1.91 + 1.91 + 2.98) + (1.91 + 1.91 + 2.98) (1.5-14.4)	13.60	3600 (200 - 3720)	15.8	16.5-15.2	3.78
(1.8 + 1.8 + 2.5) + (1.8 + 1.8 + 3.5)	13.2	(1.56 + 1.56 + 2.17) + (1.34 + 1.34 + 2.61) (1.5-13)	10.60	3200 (200 - 3360)	14.1	14.7-13.5	3.31	(1.91 + 1.91 + 2.98) + (1.73 + 1.73 + 3.33) (1.5-14.4)	13.60	3600 (200 - 3720)	15.8	16.5-15.2	3.78
(1.8 + 1.8 + 2.5) + (1.8 + 1.8 + 5.0)	14.7	(1.56 + 1.56 + 2.17) + (1.11 + 1.11 + 3.08) (1.5-13.2)	10.60	3200 (200 - 3360)	14.1	14.7-13.5	3.31	(1.91 + 1.91 + 2.98) + (1.48 + 1.48 + 3.84) (1.5-14.4)	13.60	3600 (200 - 3720)	15.8	16.5-15.2	3.78
(1.8 + 1.8 + 3.5) + (1.8 + 1.8 + 3.5)	14.2	(1.34 + 1.34 + 2.61) + (1.34 + 1.34 + 2.61) (1.5-13.2)	10.60	3200 (200 - 3360)	14.1	14.7-13.5	3.31	(1.73 + 1.73 + 3.33) + (1.73 + 1.73 + 3.33) (1.5-14.4)	13.60	3600 (200 - 3720)	15.8	16.5-15.2	3.78
(1.8 + 1.8 + 3.5) + (1.8 + 1.8 + 5.0)	15.7	(1.34 + 1.34 + 2.61) + (1.11 + 1.11 + 3.08) (1.5-13.2)	10.60	3200 (200 - 3360)	14.1	14.7-13.5	3.31	(1.73 + 1.73 + 3.33) + (1.48 + 1.48 + 3.84) (1.5-14.4)	13.60	3600 (200 - 3720)	15.8	16.5-15.2	3.78
(1.8 + 1.8 + 5.0) + (1.8 + 1.8 + 5.0)	17.2	(1.11 + 1.11 + 3.08) + (1.11 + 1.11 + 3.08) (1.5-13.2)	10.60	3200 (200 - 3360)	14.1	14.7-13.5	3.31	(1.48 + 1.48 + 3.84) + (1.48 + 1.48 + 3.84) (1.5-14.4)	13.60	3600 (200 - 3720)	15.8	16.5-15.2	3.78
(1.8 + 1.8 + 2.5) + (1.8 + 2.5 + 2.5)	12.9	(1.56 + 1.56 + 2.17) + (1.40 + 1.95 + 1.95) (1.5-13)	10.60	3200 (200 - 3360)	14.1	14.7-13.5	3.31	(1.91 + 1.91 + 2.98) + (1.65 + 2.57 + 2.57) (1.5-14.4)	13.60	3600 (200 - 3720)	15.8	16.5-15.2	3.78
(1.8 + 1.8 + 2.5) + (1.8 + 2.5 + 3.5)	13.9	(1.56 + 1.56 + 2.17) + (1.22 + 1.70 + 2.38) (1.5-13)	10.60	3200 (200 - 3360)	14.1	14.7-13.5	3.31	(1.91 + 1.91 + 2.98) + (1.52 + 2.37 + 2.91) (1.5-14.4)	13.60	3600 (200 - 3720)	15.8	16.5-15.2	3.78
(1.8 + 1.8 + 2.5) + (1.8 + 2.5 + 5.0)	15.4	(1.11 + 1.11 + 3.08) + (1.40 + 1.95 + 1.95) (1.5-13.2)	10.60	3200 (200 - 3360)	14.1	14.7-13.5	3.31	(1.48 + 1.48 + 3.84) + (1.65 + 2.57 + 2.57) (1.5-14.4)	13.60	3600 (200 - 3720)	15.8	16.5-15.2	3.78
(1.8 + 1.8 + 3.5) + (1.8 + 2.5 + 2.5)	14.9	(1.34 + 1.34 + 2.61) + (1.22 + 1.70 + 2.38) (1.5-13.2)	10.60	3200 (200 - 3360)	14.1	14.7-13.5	3.31	(1.73 + 1.73 + 3.33) + (1.52 + 2.37 + 2.91) (1.5-14.4)	13.60	3600 (200 - 3720)	15.8	16.5-15.2	3.78
(1.8 + 1.8 + 3.5) + (1.8 + 2.5 + 3.5)	16.4	(1.11 + 1.11 + 3.08) + (1.40 + 1.95 + 1.95) (1.5-13.2)	10.60	3200 (200 - 3360)	14.1	14.7-13.5	3.31	(1.48 + 1.48 + 3.84) + (1.52 + 2.37 + 2.91) (1.5-14.4)	13.60	3600 (200 - 3720)	15.8	16.5-15.2	3.78
(1.8 + 1.8 + 3.5) + (1.8 + 3.5 + 3.5)	15.9	(1.34 + 1.34 + 2.61) + (1.08 + 2.11 + 2.11) (1.5-13.2)	10.60	3200 (200 - 3360)	14.1	14.7-13.5	3.31	(1.73 + 1.73 + 3.33) + (1.40 + 2.70 + 2.70) (1.5-14.4)	13.60	3600 (200 - 3720)	15.8	16.5-15.2	3.78
(1.8 + 1.8 + 5.0) + (1.8 + 3.5 + 3.5)	17.4	(1.11 + 1.11 + 3.08) + (1.08 + 2.11 + 2.11) (1.5-13.2)	10.60	3200 (200 - 3360)	14.1	14.7-13.5	3.31	(1.48 + 1.48 + 3.84) + (1.40 + 2.70 + 2.70) (1.5-14.4)	13.60	3600 (200 - 3720)	15.8	16.5-15.2	3.78
(1.8 + 2.5 + 2.5) + (1.8 + 2.5 + 2.5)	13.6	(1.40 + 1.95 + 1.95) + (1.40 + 1.95 + 1.95) (1.5-13.2)	10.60	3200 (200 - 3360)	14.1	14.7-13.5	3.31	(1.65 + 2.57 + 2.57) + (1.65 + 2.57 + 2.57) (1.5-14.4)	13.60	3600 (200 - 3720)	15.8	16.5-15.2	3.78
(1.8 + 2.5 + 2.5) + (1.8 + 2.5 + 3.5)	14.6	(1.40 + 1.95 + 1.95) + (1.22 + 1.70 + 2.38) (1.5-13.2)	10.60	3200 (200 - 3360)	14.1	14.7-13.5	3.31	(1.65 + 2.57 + 2.57) + (1.52 + 2.37 + 2.91) (1.5-14.4)	13.60	3600 (200 - 3720)	15.8	16.5-15.2	3.78
(1.8 + 1.8 + 5.0) + (2.5 + 2.5 + 2.5)	16.1	(1.11 + 1.11 + 3.08) + (1.77 + 1.77 + 1.77) (1.5-13.2)	10.60	3200 (200 - 3360)	14.1	14.7-13.5	3.31	(1.48 + 1.48 + 3.84) + (2.27 + 2.27 + 2.27) (1.5-14.4)	13.60	3600 (200 - 3720)	15.8	16.5-15.2	3.78
(1.8 + 2.5 + 3.5) + (1.8 + 2.5 + 3.5)	15.6	(1.22 + 1.70 + 2.38) + (1.22 + 1.70 + 2.38) (1.5-13.2)	10.60	3200 (200 - 3360)	14.1	14.7-13.5	3.31	(1.52 + 2.37 + 2.91) + (1.52 + 2.37 + 2.91) (1.5-14.4)	13.60	3600 (200 - 3720)	15.8	16.5-15.2	3.78
(1.8 + 1.8 + 5.0) + (2.5 + 2.5 + 3.5)	17.1	(1.11 + 1.11 + 3.08) + (1.56 + 1.56 + 2.18) (1.5-13.2)	10.60	3200 (200 - 3360)	14.1	14.7-13.5	3.31	(1.48 + 1.48 + 3.84) + (2.00 + 2.00 + 2.80) (1.5-14.4)	13.60	3600 (200 - 3720)	15.8	16.5-15.2	3.78
(1.8 + 2.5 + 3.5) + (1.8 + 3.5 + 3.5)	16.6	(1.22 + 1.70 + 2.38) + (1.08 + 2.11 + 2.11) (1.5-13.2)	10.60	3200 (200 - 3360)	14.1	14.7-13.5	3.31	(1.52 + 2.37 + 2.91) + (1.40 + 2.70 + 2.70) (1.5-14.4)	13.60	3600 (200 - 3720)	15.8	16.5-15.2	3.78
(1.8 + 3.5 + 3.5) + (1.8 + 3.5 + 3.5)	17.6	(1.08 + 2.11 + 2.11) + (1.08 + 2.11 + 2.11) (1.5-13.2)	10.60	3200 (200 - 3360)	14.1	14.7-13.5	3.31	(1.40 + 2.70 + 2.70) + (1.40 + 2.70 + 2.70) (1.5-14.4)	13.60	3600 (200 - 3720)	15.8	16.5-15.2	3.78
(1.8 + 2.5 + 2.5) + (2.5 + 2.5 + 2.5)	14.3	(1.40 + 1.95 + 1.95) + (1.77 + 1.77 + 1.77) (1.5-13.2)	10.60	3200 (200 - 3360)	14.1	14.7-13.5	3.31	(1.65 + 2.57 + 2.57) + (2.27 + 2.27 + 2.27) (1.5-14.4)	13.60	3600 (200 - 3720)	15.8	16.5-15.2	3.78
(1.8 + 2.5 + 3.5) + (2.5 + 2.5 + 2.5)	15.3	(1.22 + 1.70 + 2.38) + (1.77 + 1.77 + 1.77) (1.5-13.2)	10.60	3200 (200 - 3360)	14.1	14.7-13.5	3.31	(1.52 + 2.37 + 2.91) + (2.27 + 2.27 + 2.27) (1.5-14.4)	13.60	3600 (200 - 3720)	15.8	16.5-15.2	3.78
(1.8 + 2.5 + 3.5) + (2.5 + 2.5 + 3.5)	16.3	(1.22 + 1.70 + 2.38) + (1.56 + 1.56 + 2.18) (1.5-13.2)	10.60	3200 (200 - 3360)	14.1	14.7-13.5	3.31	(1.52 + 2.37 + 2.91) + (2.00 + 2.00 + 2.80) (1.5-14.4)	13.60	3600 (200 - 3720)	15.8	16.5-15.2	3.78
(1.8 + 3.5 + 3.5) + (2.5 + 2.5 + 3.5)	17.3	(1.08 + 2.11 + 2.11) + (1.56 + 1.56 + 2.18) (1.5-13.2)	10.60	3200 (200 - 3360)	14.1	14.7-13.5	3.31	(1.40 + 2.70 + 2.70) + (2.00 + 2.00 + 2.80) (1.5-14.4)	13.60	3600 (200 - 3720)	15.8	16.5-15.2	3.78
(2.5 + 2.5 + 2.5) + (2.5 + 2.5 + 2.5)	15.0	(1.77 + 1.77 + 1.77) + (1.77 + 1.77 + 1.77) (1.5-13.2)	10.60	3200 (200 - 3360)	14.1	14.7-13.5	3.31	(2.27 + 2.27 + 2.27) + (2.27 + 2.27 + 2.27) (1.5-14.4)	13.60	3600 (200 - 3720)	15.8	16.5-15.2	3.78
(2.5 + 2.5 + 2.5) + (2.5 + 2.5 + 3.5)	16.0	(1.77 + 1.77 + 1.77) + (1.56 + 1.56 + 2.18) (1.5-13.2)	10.60	3200 (200 - 3360)	14.1	14.7-13.5	3.31	(2.27 + 2.27 + 2.27) + (2.00 + 2.00 + 2.80) (1.5-14.4)	13.60	3600 (200 - 3720)	15.8	16.5-15.2	3.78
(2.5 + 2.5 + 3.5) + (2.5 + 2.5 + 3.5)	17.0	(1.56 + 1.56 + 2.18) + (1.56 + 1.56 + 2.18) (1.5-13.2)	10.60	3200 (200 - 3360)	14.1	14.7-13.5	3.31	(2.00 + 2.00 + 2.80) + (2.00 + 2.00 + 2.80) (1.5-14.4)	13.60	3600 (200 - 3720)	15.8	16.5-15.2	3.78

- * FOUR INDOOR UNITS SHOULD BE CONNECTED AT LEAST .
- * ONE UNIT INDICATED ARE ONLY FOR ONE UNIT OPERATION WHEN FOUR INDOOR UNITS OR MORE ARE CONNECTED.
- * TWO UNITS INDICATED ARE ONLY FOR TWO UNITS OPERATION WHEN FOUR INDOOR UNITS OR MORE ARE CONNECTED.
- * THREE UNITS INDICATED ARE ONLY FOR THREE UNITS OPERATION WHEN FOUR INDOOR UNITS OR MORE ARE CONNECTED.
- * FOUR UNITS INDICATED ARE ONLY FOR FOUR UNITS OPERATION WHEN FOUR INDOOR UNITS OR MORE ARE CONNECTED.
- * FIVE UNITS INDICATED ARE ONLY FOR FIVE UNITS OPERATION WHEN FIVE INDOOR UNITS OR MORE ARE CONNECTED.
- * TOTAL NORNINAL COOLING CAPACITY SHOULD NOT BE MORE THAN 17.6kW.(NORNINAL COOLING CAPACITY SHOULD NOT BE MORE THAN 8.80kW FOR EACH REFRIGERANT CYCLE)

OUTDOOR CONNECTION TERMINAL	4 UNIT CONNECTION	5 UNIT CONNECTION	6 UNIT CONNECTION
INDOOR 1			1.5kW, 1.8kW, 2.5kW
INDOOR 2	1.5kW, 1.8kW, 2.5kW, 3.5kW	1.5kW, 1.8kW, 2.5kW, 3.5kW	1.5kW, 1.8kW, 2.5kW, 3.5kW
INDOOR 3	1.5kW, 1.8kW, 2.5kW, 3.5kW, 5.0kW	1.5kW, 1.8kW, 2.5kW, 3.5kW, 5.0kW	1.5kW, 1.8kW, 2.5kW, 3.5kW, 5.0kW
INDOOR 4		1.5kW, 1.8kW, 2.5kW	1.5kW, 1.8kW, 2.5kW
INDOOR 5	1.5kW, 1.8kW, 2.5kW, 3.5kW	1.5kW, 1.8kW, 2.5kW, 3.5kW	1.5kW, 1.8kW, 2.5kW, 3.5kW
INDOOR 6	1.5kW, 1.8kW, 2.5kW, 3.5kW, 5.0kW	1.5kW, 1.8kW, 2.5kW, 3.5kW, 5.0kW	1.5kW, 1.8kW, 2.5kW, 3.5kW, 5.0kW

SIX ROOM SYSTEM MULTI R.A.C. RAM-110NP6B CONNECTING POSITION ABLE TO INSTALL

6 ROOM MULTI-SPLIT INVERTER TYPE RAC: RAM-110NP6B POSSIBLE COMBINATION TO OPERATE (SAME TIME OPERATION)

POSSIBLE COMBINATIONS TO OPERATE	SUITABLE ROOM SIZE TO INSTALL (m ²)	CONNECTION POSITION ON OUTDOOR UNIT (VALVE DIAMETER) (mm)					
		NO.1	NO.2	NO.3	NO.4	NO.5	NO.6
		6.35/9.52D	6.35/9.52D	6.35/9.52D	6.35/9.52D	6.35/9.52D	6.35/9.52D
(1.5 + 1.5) + (1.5 + 1.5)	(8~12) + (8~12) + (8~12) + (8~12)		1.5	1.5		1.5	1.5
(1.5 + 1.5) + (1.5 + 1.8)	(8~12) + (8~12) + (8~12) + (8~12)		1.5	1.5		1.5	1.8
(1.5 + 1.5) + (1.5 + 2.5)	(8~12) + (8~12) + (8~12) + (11~6)		1.5	1.5		1.5	2.5
(1.5 + 1.5) + (1.5 + 3.5)	(8~12) + (8~12) + (8~12) + (16~24)		1.5	1.5		1.5	3.5
(1.5 + 1.5) + (1.5 + 5)	(8~12) + (8~12) + (6~10) + (18~27)		1.5	1.5		1.5	5
(1.5 + 1.5) + (1.8 + 2.5)	(8~12) + (8~12) + (6~10) + (11~17)		1.5	1.5		1.8	2.5
(1.5 + 1.5) + (1.8 + 3.5)	(8~12) + (8~12) + (8~12) + (16~24)		1.5	1.5		1.8	3.5
(1.5 + 1.5) + (1.8 + 5)	(8~12) + (8~12) + (7~11) + (18~26)		1.5	1.5		1.8	5
(1.5 + 1.5) + (2.5 + 3.5)	(8~12) + (8~12) + (9~15) + (13~21)		1.5	1.5		2.5	3.5
(1.5 + 1.5) + (2.5 + 5)	(8~12) + (8~12) + (8~12) + (16~24)		1.5	1.5		2.5	5
(1.5 + 1.5) + (3.5 + 5)	(8~12) + (8~12) + (9~14) + (13~21)		1.5	1.5		3.5	5
(1.5 + 1.8) + (1.5 + 1.8)	(8~12) + (8~12) + (8~12) + (8~12)		1.5	1.8		1.5	1.8
(1.5 + 1.8) + (1.8 + 1.8)	(8~12) + (8~12) + (8~12) + (8~12)		1.5	1.8		1.8	1.8
(1.5 + 1.8) + (1.8 + 2.5)	(8~12) + (8~12) + (8~12) + (8~12)		1.5	1.8		1.8	2.5
(1.5 + 1.8) + (1.8 + 3.5)	(8~12) + (8~12) + (8~12) + (16~24)		1.5	1.8		1.8	3.5
(1.5 + 1.8) + (1.8 + 5)	(8~12) + (8~12) + (7~11) + (18~26)		1.5	1.8		1.8	5
(1.5 + 1.8) + (2.5 + 2.5)	(8~12) + (8~12) + (11~17) + (11~17)		1.5	1.8		2.5	2.5
(1.5 + 1.8) + (2.5 + 3.5)	(8~12) + (8~12) + (9~15) + (13~21)		1.5	1.8		2.5	3.5
(1.5 + 1.8) + (2.5 + 5)	(8~12) + (8~12) + (8~12) + (16~24)		1.5	1.8		2.5	5
(1.5 + 1.8) + (3.5 + 3.5)	(8~12) + (8~12) + (11~17) + (11~17)		1.5	1.5		3.5	3.5
(1.5 + 1.8) + (3.5 + 5)	(8~12) + (8~12) + (9~14) + (13~21)		1.5	1.8		3.5	5
(1.5 + 2.5) + (1.5 + 2.5)	(8~12) + (11~17) + (8~12) + (11~17)		1.5	2.5		1.5	2.5
(1.5 + 2.5) + (2.5 + 2.5)	(8~12) + (11~17) + (11~17) + (11~17)		1.5	2.5		2.5	2.5
(1.5 + 2.5) + (2.5 + 3.5)	(8~12) + (11~17) + (9~15) + (13~21)		1.5	2.5		2.5	3.5
(1.5 + 2.5) + (2.5 + 5)	(8~12) + (11~17) + (8~12) + (16~24)		1.5	2.5		2.5	5
(1.5 + 2.5) + (3.5 + 3.5)	(8~12) + (11~17) + (11~17) + (11~17)		1.5	2.5		3.5	3.5
(1.5 + 2.5) + (3.5 + 5)	(8~12) + (11~17) + (9~14) + (13~21)		1.5	2.5		3.5	5
(1.5 + 2.5) + (1.5 + 3.5)	(8~12) + (16~24) + (8~12) + (16~24)		1.5	3.5		1.5	3.5
(1.5 + 3.5) + (3.5 + 3.5)	(8~12) + (16~24) + (11~17) + (11~17)		1.5	3.5		3.5	3.5
(1.5 + 3.5) + (3.5 + 5)	(8~12) + (16~24) + (9~14) + (13~21)		1.5	3.5		3.5	5
(1.5 + 5) + (1.5 + 5)	(6~10) + (18~27) + (6~10) + (18~27)		1.5	5		1.5	5
(1.8 + 1.8) + (1.8 + 1.8)	(8~12) + (8~12) + (8~12) + (8~12)		1.8	1.8		1.8	1.8
(1.8 + 1.8) + (1.8 + 2.5)	(8~12) + (8~12) + (8~12) + (10~16)		1.8	1.8		1.8	2.5
(1.8 + 2.5) + (1.8 + 2.5)	(8~12) + (10~16) + (8~12) + (10~16)		1.8	2.5		1.8	2.5
(1.8 + 1.8) + (1.8 + 3.5)	(8~12) + (8~12) + (7~9) + (15~22)		1.8	1.8		1.8	3.5
(1.8 + 2.5) + (1.8 + 3.5)	(8~12) + (10~16) + (7~9) + (15~22)		1.8	2.5		1.8	3.5
(1.8 + 1.8) + (1.8 + 5.0)	(8~12) + (8~12) + (6~9) + (18~27)		1.8	1.8		1.8	5
(1.8 + 2.5) + (1.8 + 5.0)	(8~12) + (10~16) + (6~9) + (18~27)		1.8	2.5		1.8	5
(1.8 + 3.5) + (1.8 + 3.0)	(8~12) + (10~16) + (6~9) + (18~27)		1.8	3.5		1.8	3.5
(1.8 + 3.5) + (1.8 + 5.0)	(7~9) + (15~22) + (6~9) + (18~27)		1.8	3.5		1.8	5
(1.8 + 5.0) + (1.8 + 5.0)	(6~9) + (18~27) + (6~9) + (18~27)		1.8	5		1.8	5
(1.8 + 2.5) + (2.5 + 2.5)	(8~12) + (10~16) + (12~15) + (12~15)		1.8	2.5		2.5	2.5
(1.8 + 5.0) + (2.5 + 2.5)	(6~9) + (18~27) + (12~15) + (12~15)		1.8	5		2.5	2.5
(1.8 + 3.5) + (2.5 + 2.5)	(7~9) + (15~22) + (12~15) + (12~15)		1.8	3.5		2.5	2.5
(1.8 + 3.5) + (2.5 + 3.5)	(7~9) + (15~22) + (11~14) + (14~18)		1.8	3.5		2.5	3.5
(1.8 + 5.0) + (2.5 + 3.5)	(8~12) + (8~12) + (8~12) + (8~12)		1.8	5		2.5	3.5
(1.8 + 5.0) + (2.5 + 5.0)	(6~9) + (18~27) + (10~12) + (18~20)		1.8	5		2.5	5
(1.8 + 3.5) + (3.5 + 3.5)	(7~9) + (15~22) + (13~16) + (13~16)		1.8	3.5		3.5	3.5
(1.8 + 5.0) + (3.5 + 3.5)	(6~9) + (18~27) + (13~16) + (13~16)		1.8	5		3.5	3.5
(1.8 + 5.0) + (3.5 + 5.0)	(6~9) + (18~27) + (11~14) + (16~18)		1.8	5		3.5	5
(2.5 + 2.5) + (2.5 + 2.5)	(12~15) + (12~15) + (12~15) + (12~15)		2.5	2.5		2.5	2.5
(2.5 + 2.5) + (2.5 + 2.5)	(12~15) + (12~15) + (11~14) + (14~18)		2.5	2.5		2.5	3.5
(2.5 + 2.5) + (2.5 + 5.0)	(12~15) + (12~15) + (10~12) + (18~20)		2.5	2.5		2.5	5
(2.5 + 3.5) + (2.5 + 3.5)	(11~14) + (14~18) + (11~14) + (14~18)		2.5	3.5		2.5	3.5
(2.5 + 5.0) + (2.5 + 3.5)	(10~12) + (18~20) + (11~14) + (14~18)		2.5	5		2.5	3.5
(2.5 + 5.0) + (2.5 + 5.0)	(10~12) + (18~20) + (10~12) + (18~20)		2.5	5		2.5	5
(2.5 + 3.5) + (3.5 + 3.5)	(11~14) + (14~18) + (13~16) + (13~16)		2.5	3.5		3.5	3.5
(2.5 + 5.0) + (3.5 + 3.5)	(10~12) + (18~20) + (13~16) + (13~16)		2.5	5		3.5	3.5
(3.5 + 3.5) + (3.5 + 3.5)	(13~16) + (13~16) + (13~16) + (13~16)		3.5	3.5		3.5	3.5
(3.5 + 3.5) + (3.5 + 5.0)	(13~16) + (13~16) + (11~14) + (16~18)		3.5	3.5		3.5	5
(3.5 + 5.0) + (3.5 + 5.0)	(11~14) + (16~18) + (11~14) + (16~18)		3.5	5		3.5	5

FOUR UNITS

(1.5 + 2.5) + (1.8 + 1.8 + 2.5)	(8~12) + (11~17) + (8~12) + (8~12) + (9~14)		1.5	2.5	1.8	1.8	2.5
(1.5 + 2.5) + (1.8 + 1.8 + 3.5)	(8~12) + (11~17) + (7~11) + (7~11) + (11~17)		1.5	2.5	1.8	1.8	3.5
(1.5 + 2.5) + (1.5 + 1.8 + 5.0)	(8~12) + (11~17) + (6~9) + (6~9) + (13~21)		1.5	2.5	1.8	1.8	5
(1.5 + 2.5) + (1.8 + 2.5 + 2.5)	(8~12) + (11~17) + (7~11) + (8~13) + (8~13)		1.5	2.5	1.8	2.5	2.5
(1.5 + 2.5) + (1.8 + 2.5 + 3.5)	(8~12) + (11~17) + (6~10) + (8~12) + (11~16)		1.5	2.5	1.8	2.5	3.5
(1.5 + 2.5) + (1.8 + 3.5 + 3.5)	(8~12) + (11~17) + (6~9) + (9~14) + (9~14)		1.5	2.5	1.8	3.5	3.5
(1.5 + 2.5) + (2.5 + 2.5 + 2.5)	(8~12) + (11~17) + (8~12) + (8~12) + (8~12)		1.5	2.5	2.5	2.5	2.5
(1.5 + 2.5) + (2.5 + 2.5 + 3.5)	(8~12) + (11~17) + (8~12) + (8~12) + (9~14)		1.5	2.5	2.5	2.5	3.5
(1.5 + 3.5) + (1.5 + 1.5 + 1.5)	(8~12) + (16~24) + (8~12) + (8~12) + (8~12)		1.5	3.5	1.5	1.5	1.5
(1.5 + 3.5) + (1.5 + 1.5 + 1.8)	(8~12) + (16~24) + (8~12) + (8~12) + (8~12)		1.5	3.5	1.5	1.5	1.8
(1.5 + 3.5) + (1.5 + 1.5 + 2.5)	(8~12) + (16~24) + (7~11) + (7~11) + (11~16)		1.5	3.5	1.5	1.5	2.5
(1.5 + 3.5) + (1.5 + 1.5 + 3.5)	(8~12) + (16~24) + (6~10) + (6~10) + (12~19)		1.5	3.5	1.5	1.5	3.5
(1.5 + 3.5) + (1.5 + 1.5 + 5.0)	(8~12) + (16~24) + (6~9) + (6~9) + (14~22)		1.5	3.5	1.5	1.5	5
(1.5 + 3.5) + (1.5 + 1.8 + 1.8)	(8~12) + (16~24) + (8~12) + (8~12) + (8~12)		1.5	3.5	1.5	1.8	1.8
(1.5 + 3.5) + (1.5 + 1.8 + 2.5)	(8~12) + (16~24) + (7~11) + (8~12) + (9~15)		1.5	3.5	1.5	1.8	2.5
(1.5 + 3.5) + (1.5 + 1.8 + 3.5)	(8~12) + (16~24) + (6~10) + (7~11) + (12~18)		1.5	3.5	1.5	1.8	3.5
(1.5 + 3.5) + (1.5 + 1.8 + 5.0)	(8~12) + (16~24) + (6~9) + (6~10) + (14~21)		1.5	3.5	1.5	1.8	5
(1.5 + 3.5) + (1.5 + 2.5 + 2.5)	(8~12) + (16~24) + (6~10) + (9~13) + (9~13)		1.5	3.5	1.5	2.5	2.5
(1.5 + 3.5) + (1.5 + 2.5 + 3.5)	(6~9) + (16~24) + (6~9) + (8~12) + (11~16)		1.5	3.5	1.5	2.5	3.5
(1.5 + 3.5) + (1.5 + 3.5 + 3.5)	(8~12) + (16~24) + (6~9) + (9~14) + (9~14)		1.5	3.5	1.5	3.5	3.5
(1.5 + 3.5) + (1.8 + 1.8 + 1.8)	(8~12) + (16~24) + (8~12) + (8~12) + (8~12)		1.5	3.5	1.8	1.8	1.8
(1.5 + 3.5) + (1.8 + 1.8 + 2.5)	(8~12) + (16~24) + (8~12) + (8~12) + (9~14)		1.5	3.5	1.8	1.8	2.5
(1.5 + 3.5) + (1.8 + 1.8 + 3.5)	(8~12) + (16~24) + (7~11) + (7~11) + (11~17)		1.5	3.5	1.8	1.8	3.5
(1.5 + 3.5) + (1.8 + 1.8 + 5.0)	(8~12) + (16~24) + (6~9) + (6~9) + (13~21)		1.5	3.5	1.8	1.8	5
(1.5 + 3.5) + (1.8 + 2.5 + 2.5)	(8~12) + (16~24) + (7~11) + (8~13) + (8~13)		1.5	3.5	1.8	2.5	2.5
(1.5 + 3.5) + (1.8 + 2.5 + 3.5)	(8~12) + (16~24) + (6~10) + (8~12) + (11~16)		1.5	3.5	1.8	2.5	3.5
(1.5 + 3.5) + (1.8 + 3.5 + 3.5)	(8~12) + (16~24) + (6~9) + (9~14) + (9~14)		1.5	3.5	1.8	3.5	3.5
(1.5 + 3.5) + (2.5 + 2.5 + 2.5)	(8~12) + (16~24) + (8~12) + (8~12) + (8~12)		1.5	3.5	2.5	2.5	2.5
(1.5 + 3.5) + (2.5 + 2.5 + 3.5)	(8~12) + (16~24) + (8~12) + (8~12) + (9~14)		1.5	3.5	2.5	2.5	3.5
(1.5 + 5.0) + (1.5 + 1.5 + 1.5)	(6~10) + (18~27) + (8~12) + (8~12) + (8~12)		1.5	5	1.5	1.5	1.5
(1.5 + 5.0) + (1.5 + 1.5 + 1.8)	(6~10) + (18~27) + (8~12) + (8~12) + (8~12)		1.5	5	1.5	1.5	1.8
(1.5 + 5.0) + (1.5 + 1.5 + 2.5)	(6~10) + (18~27) + (7~11) + (7~11) + (11~16)		1.5	5	1.5	1.5	2.5
(1.5 + 5.0) + (1.5 + 1.5 + 3.5)	(6~10) + (18~27) + (6~10) + (6~10) + (12~19)		1.5	5	1.5	1.5	3.5
(1.5 + 5.0) + (1.5 + 1.5 + 5.0)	(6~10) + (18~27) + (6~9) + (6~9) + (14~22)		1.5	5	1.5	1.5	5
(1.5 + 5.0) + (1.5 + 1.8 + 1.8)	(6~10) + (18~27) + (8~12) + (8~12) + (8~12)		1.5	5	1.5	1.8	1.8
(1.5 + 5.0) + (1.5 + 1.8 + 2.5)	(6~10) + (18~27) + (7~11) + (8~12) + (9~15)		1.5	5	1.5	1.8	2.5
(1.5 + 5.0) + (1.5 + 1.8 + 3.5)	(6~10) + (18~27) + (6~10) + (7~11) + (12~18)		1.5	5	1.5	1.8	3.5
(1.5 + 5.0) + (1.5 + 1.8 + 5.0)	(6~10) + (18~27) + (6~9) + (6~10) + (14~21)		1.5	5	1.5	1.8	5
(1.5 + 5.0) + (1.5 + 2.5 + 2.5)	(6~10) + (18~27) + (6~10) + (9~13) + (9~13)		1.5	5	1.5	2.5	2.5
(1.5 + 5.0) + (1.5 + 2.5 + 3.5)	(6~10) + (18~27) + (6~9) + (8~12) + (11~16)		1.5	5	1.5	2.5	3.5
(1.5 + 5.0) + (1.5 + 3.5 + 3.5)	(6~10) + (18~27) + (6~9) + (9~14) + (9~14)		1.5	5	1.5	3.5	3.5
(1.5 + 5.0) + (1.8 + 1.8 + 1.8)	(6~10) + (18~27) + (8~12) + (8~12) + (8~12)		1.5	5	1.8	1.8	1.8
(1.5 + 5.0) + (1.8 + 1.8 + 2.5)	(6~10) + (18~27) + (8~12) + (8~12) + (9~14)		1.5	5	1.8	1.8	2.5
(1.5 + 5.0) + (1.8 + 1.8 + 3.5)	(6~10) + (18~27) + (7~11) + (7~11) + (11~17)		1.5	5	1.8	1.8	3.5
(1.5 + 5.0) + (1.8 + 1.8 + 5.0)	(6~10) + (18~27) + (6~9) + (6~9) + (13~21)		1.5	5	1.8	1.8	5
(1.5 + 5.0) + (1.8 + 2.5 + 2.5)	(6~10) + (18~27) + (7~11) + (8~13) + (8~13)		1.5	5	1.8	2.5	2.5
(1.5 + 5.0) + (1.8 + 2.5 + 3.5)	(6~10) + (18~27) + (6~10) + (8~12) + (11~16)		1.5	5	1.8	2.5	3.5
(1.5 + 5.0) + (1.8 + 3.5 + 3.5)	(6~10) + (18~27) + (6~9) + (9~14) + (9~14)		1.5	5	1.8	3.5	3.5
(1.5 + 5.0) + (2.5 + 2.5 + 2.5)	(6~10) + (18~27) + (8~12) + (8~12) + (8~12)		1.5	5	2.5	2.5	2.5
(1.5 + 5.0) + (2.5 + 2.5 + 3.5)	(6~10) + (18~27) + (8~12) + (8~12) + (9~14)		1.5	5	2.5	2.5	3.5

DUAL AND TRIPLE SYSTEM MULTI R.A.C. RAM-110NP6B INDOOR UNITS COMBINATIONS TO BE ABLE TO INSTALL

Two or three indoor units can be installed with one outdoor unit.
And total nominal cooling capacity should not be more than 8.5kW

NOMINAL COOLING CAPACITY (kW)	INDOOR UNIT MODEL	CAPACITY (kW) at one unit operation		SUITABLE ROOM SIZE (m ²) at one unit operation	
		COOLING	HEATING	COOLING	HEATING
1.5kW	RAK-15QPB	1.00 ~ 1.60	1.10 ~ 2.20	8 ~ 12	9 ~ 11
1.8kW	RAK-18RPB	1.50 ~ 2.00	1.80 ~ 3.50	8 ~ 12	9 ~ 11
	RAK-18QXB	1.50 ~ 2.00	1.80 ~ 3.50	8 ~ 12	9 ~ 11
	RAD-18QPB	1.50 ~ 2.00	1.80 ~ 3.50	8 ~ 12	9 ~ 11
	RAF-18QXB	1.50 ~ 2.00	1.80 ~ 3.50	8 ~ 12	9 ~ 11
2.5kW	RAK-25RPB	1.50 ~ 2.80	1.80 ~ 4.70	11 ~ 17	14 ~ 18
	RAK-25RXB	1.50 ~ 2.80	1.80 ~ 4.70	11 ~ 17	14 ~ 18
	RAD-25QPB	1.50 ~ 2.80	1.80 ~ 4.70	11 ~ 17	14 ~ 18
	RAI-25QPB	1.50 ~ 2.80	1.80 ~ 4.70	11 ~ 17	14 ~ 18
	RAF-25RXB	1.50 ~ 2.80	1.80 ~ 4.70	11 ~ 17	14 ~ 18
3.5kW	RAK-35RPB	1.50 ~ 3.90	1.80 ~ 5.80	16 ~ 24	17 ~ 22
	RAK-35RXB	1.50 ~ 3.90	1.80 ~ 5.80	16 ~ 24	17 ~ 22
	RAD-35QPB	1.50 ~ 3.90	1.80 ~ 5.80	16 ~ 24	17 ~ 22
	RAI-35QPB	1.50 ~ 3.90	1.80 ~ 5.80	16 ~ 24	17 ~ 22
	RAF-35RXB	1.50 ~ 3.90	1.80 ~ 5.80	16 ~ 24	17 ~ 22
5.0kW	RAK-50RPB	1.50 ~ 5.60	1.80 ~ 7.20	23 ~ 34	23 ~ 29
	RAK-50RXB	1.50 ~ 5.60	1.80 ~ 7.20	23 ~ 34	23 ~ 29
	RAD-50QPB	1.50 ~ 5.60	1.80 ~ 7.20	23 ~ 34	23 ~ 29
	RAI-50QPB	1.50 ~ 5.60	1.80 ~ 7.20	23 ~ 34	23 ~ 29
	RAF-50RXB	1.50 ~ 5.60	1.80 ~ 7.20	23 ~ 34	23 ~ 29

Be sure to connect two or three indoor units to this outdoor unit. If not, condensed water may drop, resulting in trouble.

At least four indoor unit to be connected to the outdoor unit which means two indoor unit for each cycle (upper and lower). Anyway indoor unit 3 and 6 must be connected.

FEATURES

1. NEW REFRIGERANT

(1) New refrigerant R410A with no harmful effect on the ozone layer

Refrigerant R410A, which does not damage the ozone layer, was adopted instead of HCFC-22 which is planned to be phased out globally by 2020.

(2) New refrigerating oil

The new refrigerant HFC-R410A is not compatible with conventional mineral oils and no lubrication can be expected with those oils. To solve this, the artificial synthetic ester oil is newly adopted.

Cautions in relation to HFC (R410A)

1. Safety during Servicing

This air conditioner uses the new refrigerant HFC (R410A) for protecting the ozone layer. R410A has several different characteristic features from HCFC-22. Therefore keep the following care items during servicing for safety.

- (1) Since the working pressure of R410A model is about 1.6 times higher than that of HCFC-22 models, it becomes necessary to use part of piping materials and servicing tools exclusive for R410A model.
- (2) It is necessary to exercise more care to prevent the foreign matters (oil, moisture, etc.) from mixing into the piping than in the case of HCFC-22 model. Also, when storing the piping, securely seal its openings with pinching and taping, etc..
- (3) Be sure to charge the refrigerant from the liquid-phase side, as the liquid-phase/gas-phase-composition changes a little in the case of R410A model.
- (4) Never use refrigerant other than R410A in an air conditioner which is designed to operate with R410A.
- (5) If a refrigeration gas leakage occurs during servicing, be sure to ventilate fully.
If the refrigerant gas comes into contact with fire, a poisonous gas may occur.
- (6) When installing or removing an air conditioner, do not allow air or moisture to remain in the refrigeration cycle. Otherwise, pressure in the refrigeration cycle may become abnormally high so that a rupture or personal injury may be caused.
- (7) After completion of service work, check to make sure that there is no refrigeration gas leakage.
If the refrigerant gas leaks into the room, coming into contact with fire in the fan-driven heater, space heater, etc., a poisonous gas may occur.

2. Refrigerant Piping Materials

(1) Thickness of Refrigerant Piping

Although the thickness is same as that for HCFC-22 model, as R410A model features higher pressure, be sure to confirm the thickness prior to use.

※Do not use thin pipes (thinner than 0.7 mm).

Nominal diameter	Outside diameter (mm)	Thickness (mm)
1/4	6.35	0.8
3/8	9.52	0.8
1/2	12.70	0.8

(2) Flare's Expansion Pipe

The projection when the new flare tool is used, is as follows. When using the conventional flare tool, be sure to secure the following projection by using a gauge for projection adjustment.

※When using the conventional flare tool, use a gauge for projection adjustment.

Projection "A"(mm) for Flare Tool for R410A (Clutch Type)

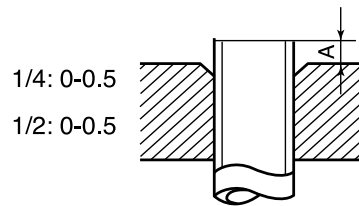

(3) Flare Nut Dimensions

Along with changes in the expansion pipe dimensions, the opposite side dimensions of flare nuts whose nominal diameter is 1/2 change so that different torque wrenches must be used.

※Figures in () denote those for HCFC-22.

Nominal diameter	Opposite Side Dimensions (mm) of Flare Nuts for R410A
1/4	17 (17)
3/8	22 (22)
1/2	26 (24)

3. Servicing Tools

(Changes in the Product and Components)

- In order to prevent any other refrigerant from being charged, R410A model is provided with the outdoor unit whose control valve has a different service port diameter (port size: 7/16 UNF 20 threads per inch → 1/2 UNF 20 threads per inch).
- In order to secure larger pressure resisting strength, flare expansion pipe dimensions and flare nut dimensions have been changed.

(New Tools for R410A)

New tools for R410A	Applicable to HCFC-22 Model	Changes
Gauge manifold	×	As pressure is high, it is impossible to measure by means of conventional gauge. In order to prevent any other refrigerant from being charged, each port diameter has been changed.
Charge hose	×	In order to increase pressure resistance, hose materials and port size have been changed (to 1/2 UNF 20 threads per inch). When purchasing a charge hose, be sure to confirm the port size.
Electronic balance for refrigerant charging	○	As pressure is high and gasification speed is fast, it is difficult to read the indicated value by means of charging cylinder, as air bubbles occur.
Torque wrench	×	The opposite side dimensions of flare nuts increase. Incidentally, a common wrench is used for nominal diameters 1/4 and 3/8.
Flare tool (clutch type)	○	By increasing the clamp bar's receiving hole, strength of spring in the tool has been improved.
Gauge for projection adjustment	—	Used when performing flare processing by means of conventional flare tool.
Vacuum pump adapter	○	Connected to conventional vacuum pump.
Gas leakage detector	×	Exclusive for HFC refrigerant.

- Incidentally, the "refrigerant cylinder" comes with the refrigerant designation (R410A) and protector coating in the U.S.'s ARI specified rose color (ARI color code: PMS 507).
- Also, the "charge port and packing for refrigerant cylinder" require 1/2 UNF 20 threads per inch corresponding to the charge hose's port size.

4. Servicing work (Refrigerant recharging)

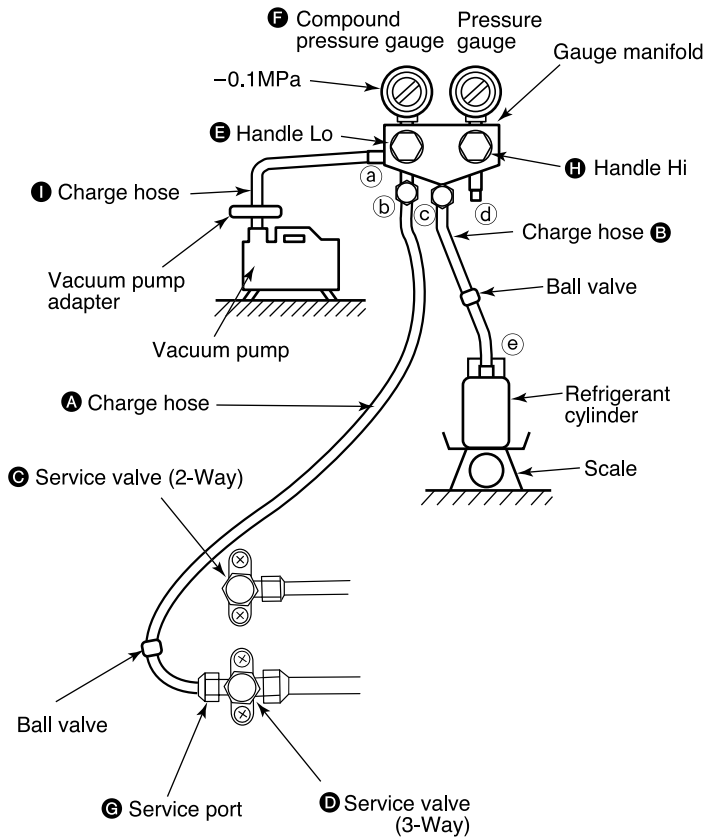

Working steps

1. Connect the charge hose **A** to outdoor unit.
2. Connect the vacuum pump adapter to the vacuum pump. Connect the 1/2" conversion adapter to the vacuum pump adapter. Connect the charge hose **1** to the conversion adapter.
Then, service valve **C** & **D** is closed.
3. Connect the charge hose **B** to the refrigerant cylinder.
4. Open the handle Lo **E**.
Turn ON the power switch of the vacuum pump & adapter.
Run the vacuum pump in specified time.
Turn OFF the power switch of the vacuum pump & adapter.
5. When the compound pressure gauge's pointer has indicated -0.1MPa, place the handle Lo **E** in the fully closed position.
6. Remove the charge hose **1** of vacuum pump at portion **a**.
7. Air purge of gauge manifold.
• Open the refrigerant cylinder's valve and push the valve core at portion **a** of gauge manifold. Then the refrigerant is discharge in a moment.
8. Calculation of charged refrigerant amount.
9. Charging of refrigeration.
• Open the handle Lo **E** in a turn and charge the designated amount.
10. Completion of charging.
11. Be closed the valve of charge hose **A**.
12. Run the compressor at cooling operation.
13. Remove the charge hose **A** & **B**.
• Remove the charge hose **A** rom portion **C**.
• Remove the charge hose **B** from portion **e**.
14. Attach the caps.
15. Gas leakage check.

CAUTION

1. Be sure to use the vacuum pump, vacuum pump adapter and gauge manifold to refer to their instruction manuals beforehand.
2. Ascertain that the vacuum pump is filled with oil to the level designated on the oil gauge.
3. After closed the ball valve of charge hose, it should be disconnected at service port side and refrigerant cylinder side at first.
Next, after discharging the remained gas in the charge hose by opening the ball valve a little, disconnect it at gauge manifold side. You can prevent from being released the refrigerant suddenly by connecting the ball valve to service port. And you can work with more safety.

INSTALLATION

PIPE LENGTH

- (1) Total 45m maximum pipe length for each refrigerant cycle (upper cycle and lower cycle).
- (2) Pipe length for one indoor unit : maximum 25m.

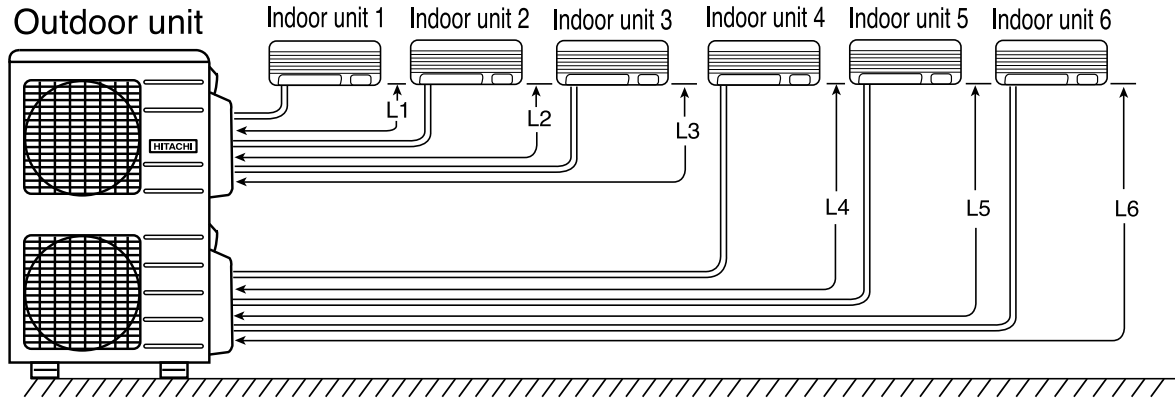

$(L1 + L2 + L3) = (L4 + L5 + L6) = \text{Maximum } 45\text{m}$
 However $(L2 + L3) = (L5 + L6) = \text{Maximum } 35\text{m}$
 Minimum piping length for each indoor unit is 3m.
 Maximum piping length for one indoor unit is 25m.
 ※ In case the pipe length is more than 35m, add refrigerant R410A at 20 gram per every meter exceeds.

Hight Difference between indoor units should be not more than 5m

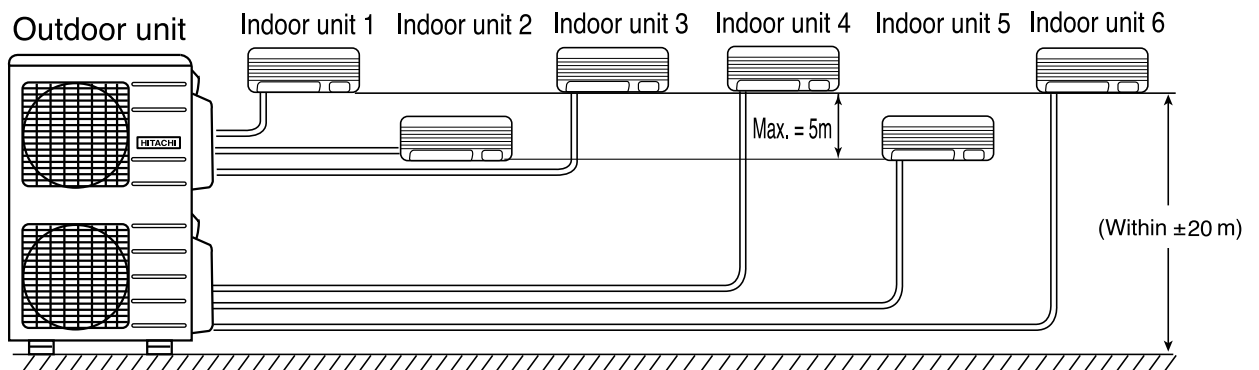

- To the outdoor unit, up to three indoor units can be connected until the total value of capacity from 5.0kW to 9.0kW for each refrigerant cycle (upper cycle and lower cycle).
- Make sure to connect to two or three indoor units for each refrigerant cycle.

MODEL: RAM-110NP6B

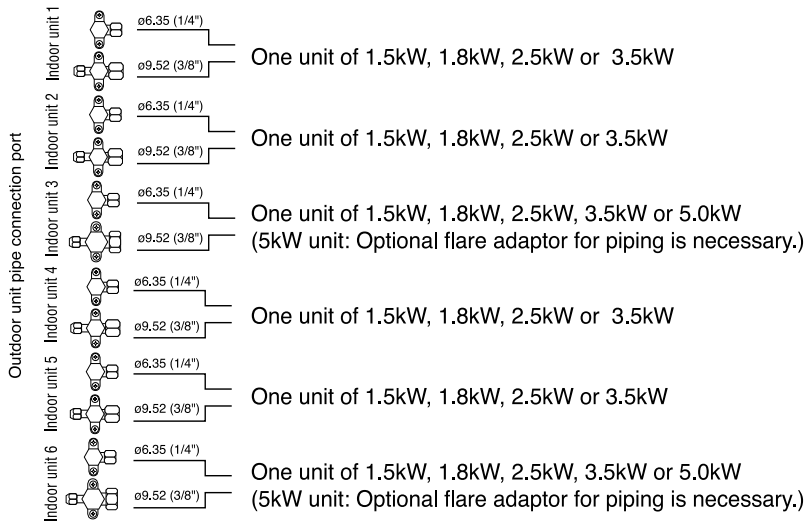

- Remove the side cover.
- For installation, refer as shown below.
- The space indicated with a ⇔ mark is required to guarantee the air conditioner's performance. Install the air conditioner in a place big enough to provide ample space for servicing and repairs later on.

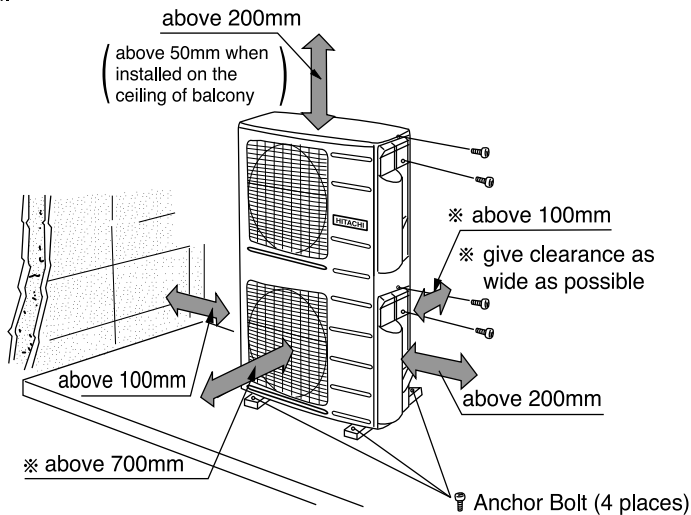

Connecting the pipe

- Install the unit in a stable place to minimize vibration or noise.
- After arranging the cord and pipes, secure them in place.

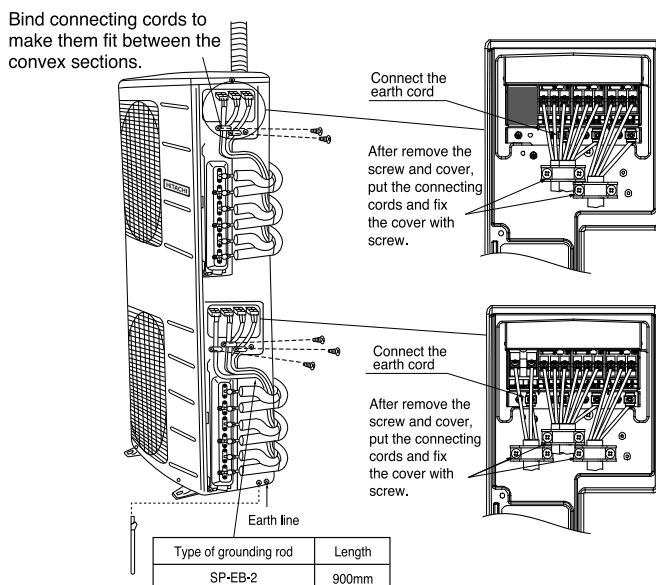

- Hold the handle of the side cover. Slide down and take off the corner hook, then pull. Reverse these steps when installing.

Flare adaptor for piping

The flare adaptor for piping is required depending on combination of indoor units.

- ø9.52 (3/8") → ø12.7 (1/2") parts number TA261D-4 001

CAUTION

- This outdoor unit contains 2 different refrigerant cycles with two compressors and two separated electricals.
- For refrigerant cycle at upper side of unit, shall be for connection for indoor 1, 2 and 3.
- For refrigerant cycle at lower side of unit, shall be for connection for indoor 4, 5 and 6.
- Each refrigerant cycle must be connected indoor units at least 2 connections.
- And connection no. 3 and no. 6 are compulsory. If not, there will be an icing at the condenser base during winter season.

1. Remove flare nut from service valve.
2. Apply refrigerant oil to flare nut sections of service valve and pipings.
3. Match center of piping to large diameter side service valve and tank assembly, and tighten flarenut first by hand, then securely tighten using torque wrench.
4. Perform air purge and gas leak inspection.
5. Wrap the provided insulating material around side piping using vinyl tape.

Condensed water disposal of outdoor unit

- There is holes on the base of outdoor unit for condensed water to exhaust.
- To lead condensed water to the drain hole, place the outdoor unit on the mounting stand (optional) or on blocks to raise its level more than 100mm from the ground surface. Connect the drain pipe as shown in the figure. Cover two other water drain holes with the bushings included. (To insall a bushing, push in both ends of the bushing so that it aligns with the drain hole.)
- When connecting the drain pipe, make sure that the bushing does not lift off or deviate from the base.
- Install the outdoor unit on a stable, flat surface and check to see that the condensed water drains.

When Using and Installing in Cold Areas

When the air conditioner is used in low temperature and in snowy conditions, water from the heat exchanger may freeze on the base surface to cause poor drainage. When using the air conditioner in such areas, do not install the bushings. Keep a minimum of 250mm between the drain hole and the ground. When using the drain pipe, consult your sales agent.

※ For more details, refer to the Installation Manual for Cold Areas.

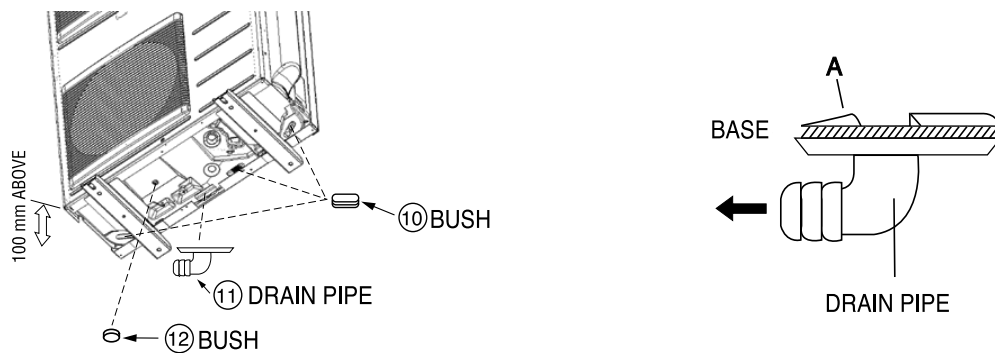

Connection of the connecting cords and power cord. (Outdoor unit)

RAM-110NP6B

⚠ WARNING

- Connecting cord should be connected according to Fig.1, that the Indoor unit No. shall match with terminal board No. of Outdoor unit.
- Be sure to fix the connecting cord with the band as shown below. Otherwise water leakage causes short circuit or faults.

Bind connecting cords to make them fit between the convex sections.

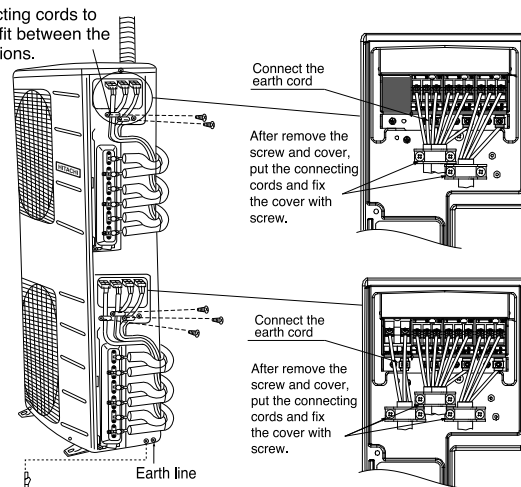

Connect the earth cord

After remove the screw and cover, put the connecting cords and fix the cover with screw.

Connect the earth cord

After remove the screw and cover, put the connecting cords and fix the cover with screw.

Earth line

Grounding rod (optional)

(Earth line and grounding rod are not supplied.)
Please use optional items below.

Type of grounding rod	Length
SP-EB-2	900mm

⚠ CAUTION

- If earth line cannot be taken from the power supply connection, use the optional grounding rod to do earthing.

Wiring Pattern

Indoor Unit

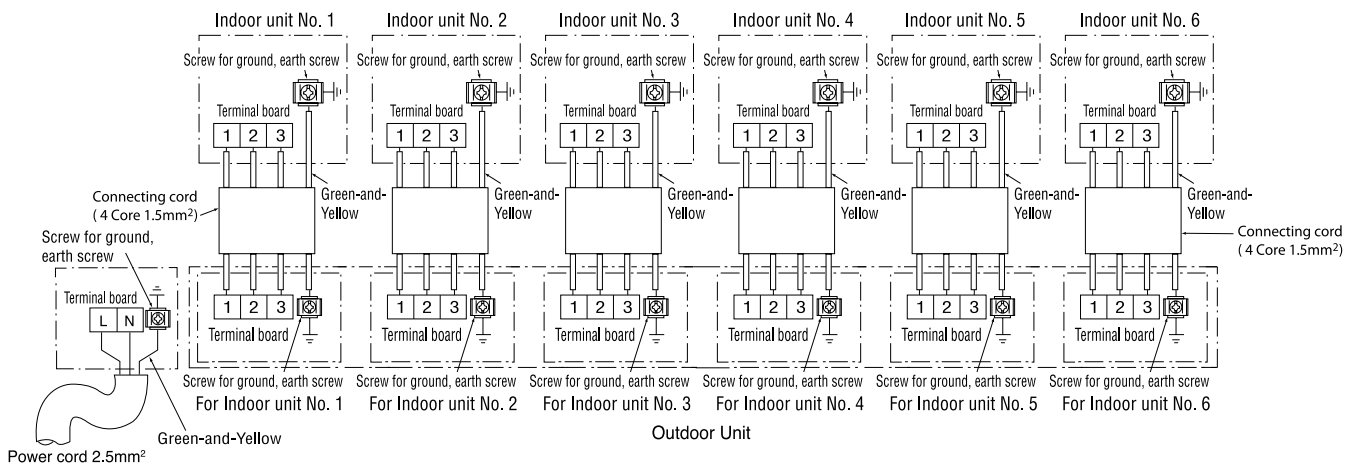

⚠ WARNING

Connection of the power cord and connecting cord

-
- Securely screw in the power cord and connecting cord so that it will not get loose or disconnect.
 - Tightening torque reference value:
1.2 to 1.6 N·m (12 to 16 kgf·cm)
 - Excessive tightening may damage the interior of the cord requiring replacement.

⚠ CAUTION

- To prevent a connection error, connecting cords should be bundled and taped to each respective pipe. If connecting cords are mixed with other indoor units, a refrigeration cycle abnormality may occur, causing dripping.

- When putting two connecting cords through the band.

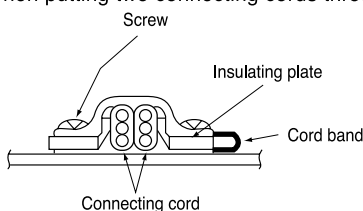

⚠ WARNING

- Leave some space in the connecting cord for maintenance purpose and be sure to secure it with the cord band.
- Secure the connecting cord along the coated part of the wire using the cord band. Do not exert pressure on the wire as this may cause overheating or fire.

- Hold the handle of the side cover, slide down and take off the corner hook, then pull. Reverse these steps when installing.

CONSTRUCTION AND DIMENSIONAL DIAGRAM

MODEL RAM-110NP6B

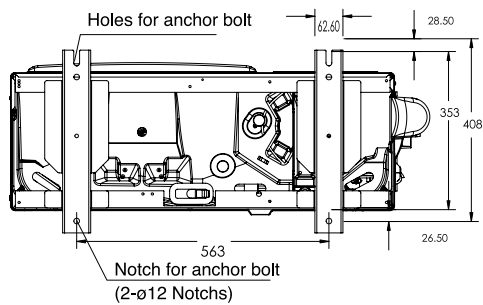
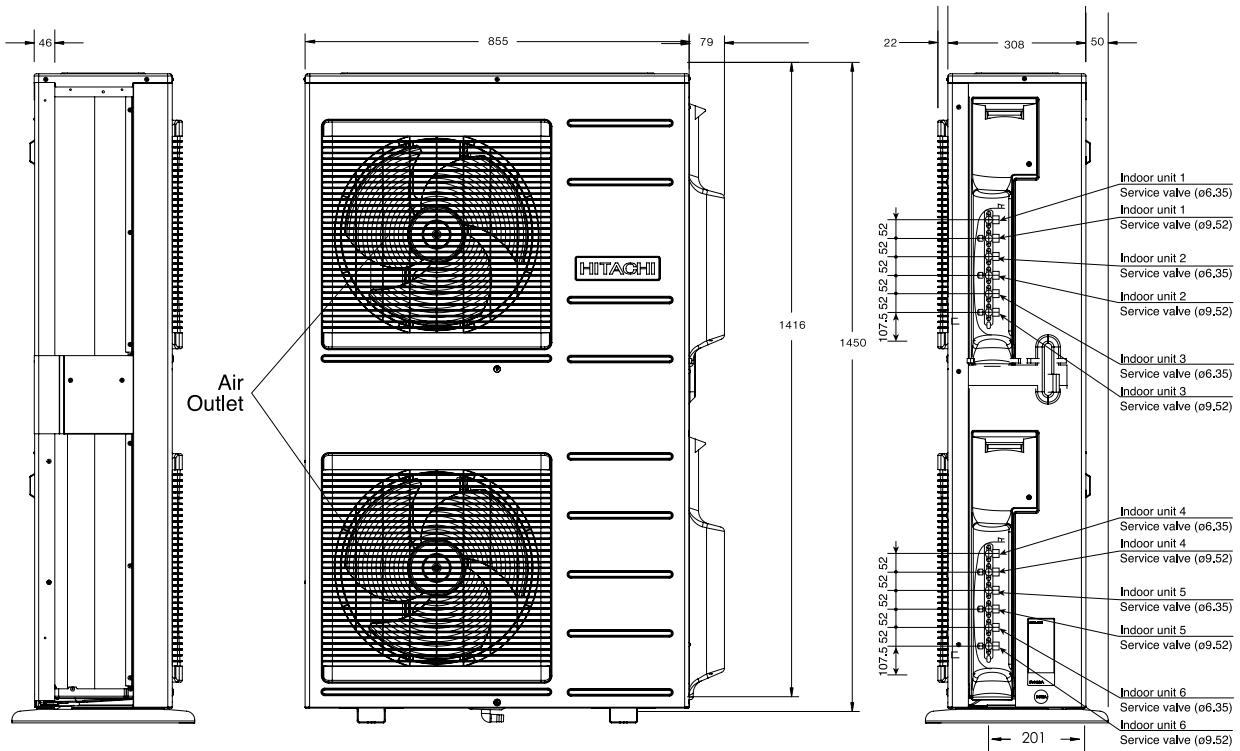

Service space

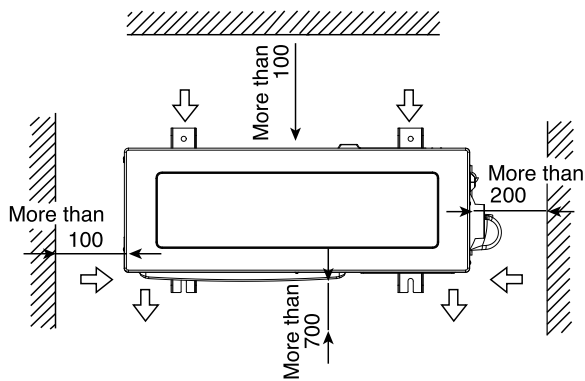

Note:

1. Insulated pipes should be used for both small and large diameter pipes.
2. Piping length should be within 25m for one room and within 45m in total.
3. Height difference of piping between indoor unit and outdoor unit should be within 20m.
4. Overhead clearance of outdoor unit should be 200mm to allow servicing.
5. For electrical connection, please refer to the installation manual.

ATTENTION

During service, before opening the side cover, please switch off power supply.

MAIN PARTS COMPONENT

FAN MOTOR

Fan Motor Specifications

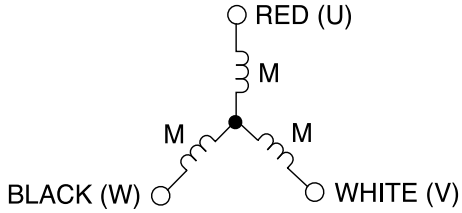
MODEL		RAM-110NP6B
POWER SOURCE		DC : 120-380V
OUTPUT		47W
CONNECTION		
RESISTANCE VALUE (Ω)	20°C (68°F)	38.2 ± 3.9

BLU : BLUE

YEL : YELLOW

BRN : BROWN

WHT : WHITE

GRY : GRAY

ORN : ORANGE

GRN : GREEN

RED : RED

BLK : BLACK

PNK : PINK

VIO : VIOLET

COMPRESSOR

Compressor Motor Specifications

MODEL	RAM-110NP6B	
COMPRESSOR MODEL	JU1015D9	
PHASE	SINGLE	
RATED VOLTAGE	AC: 220-240V	
RATED FREQUENCY	50/60Hz	
POLE NUMBER	4	
CONNECTION		
RESISTANCE VALUE (Ω)	20°C (68°F)	2M = 1.298 \pm 7%
	75°C (167°F)	2M = 1.579 \pm 7%

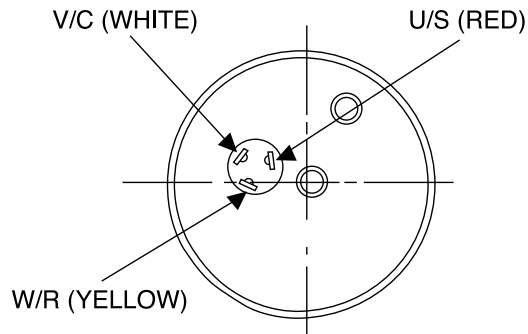

WIRING DIAGRAM

OUTDOOR UNIT 1

OUTDOOR UNIT 2

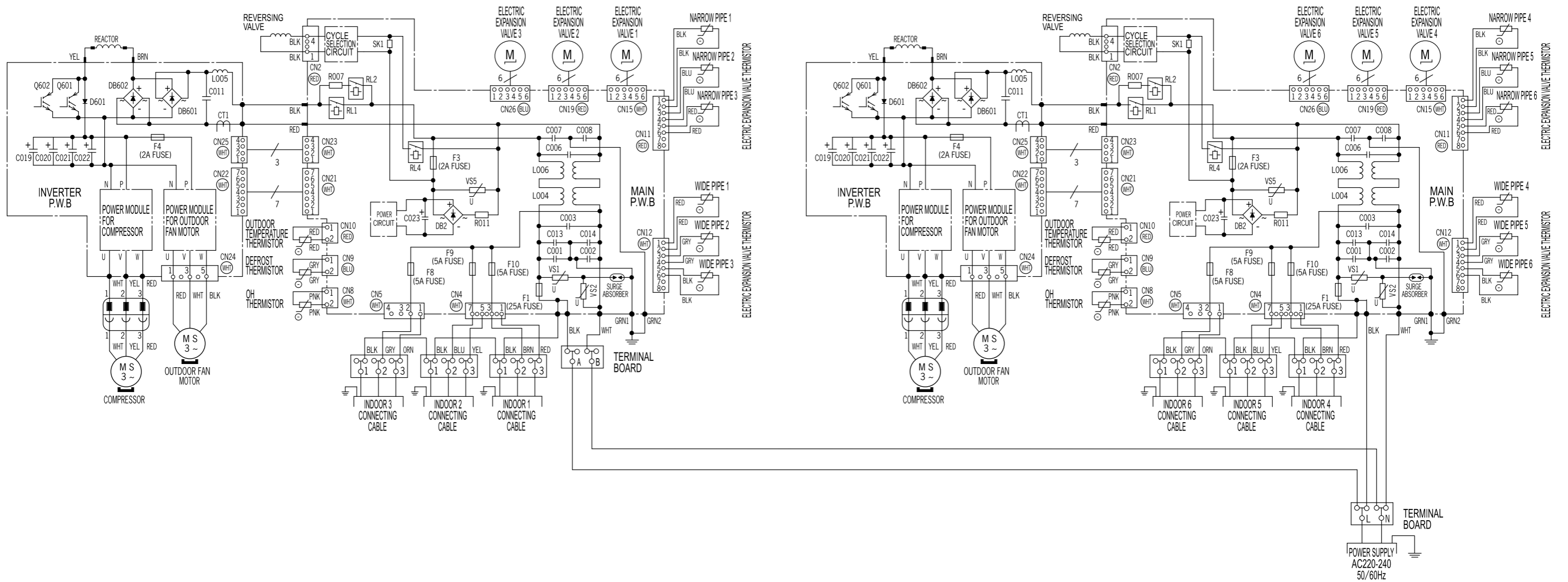

CIRCUIT DIAGRAM

OUTDOOR UNIT 1
(CONNECTED TO INDOOR 1, INDOOR2 & INDOOR 3)

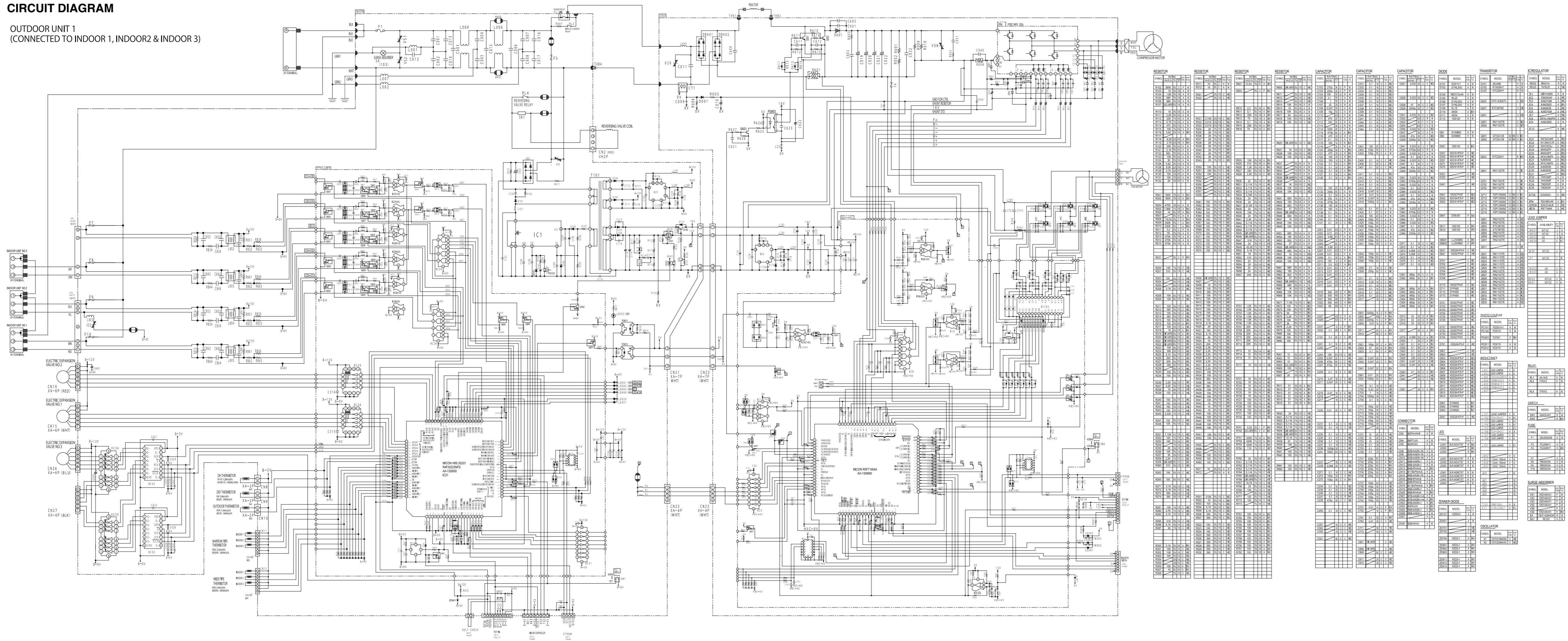

BLOCK DIAGRAM
MODEL RAM-110NP6B

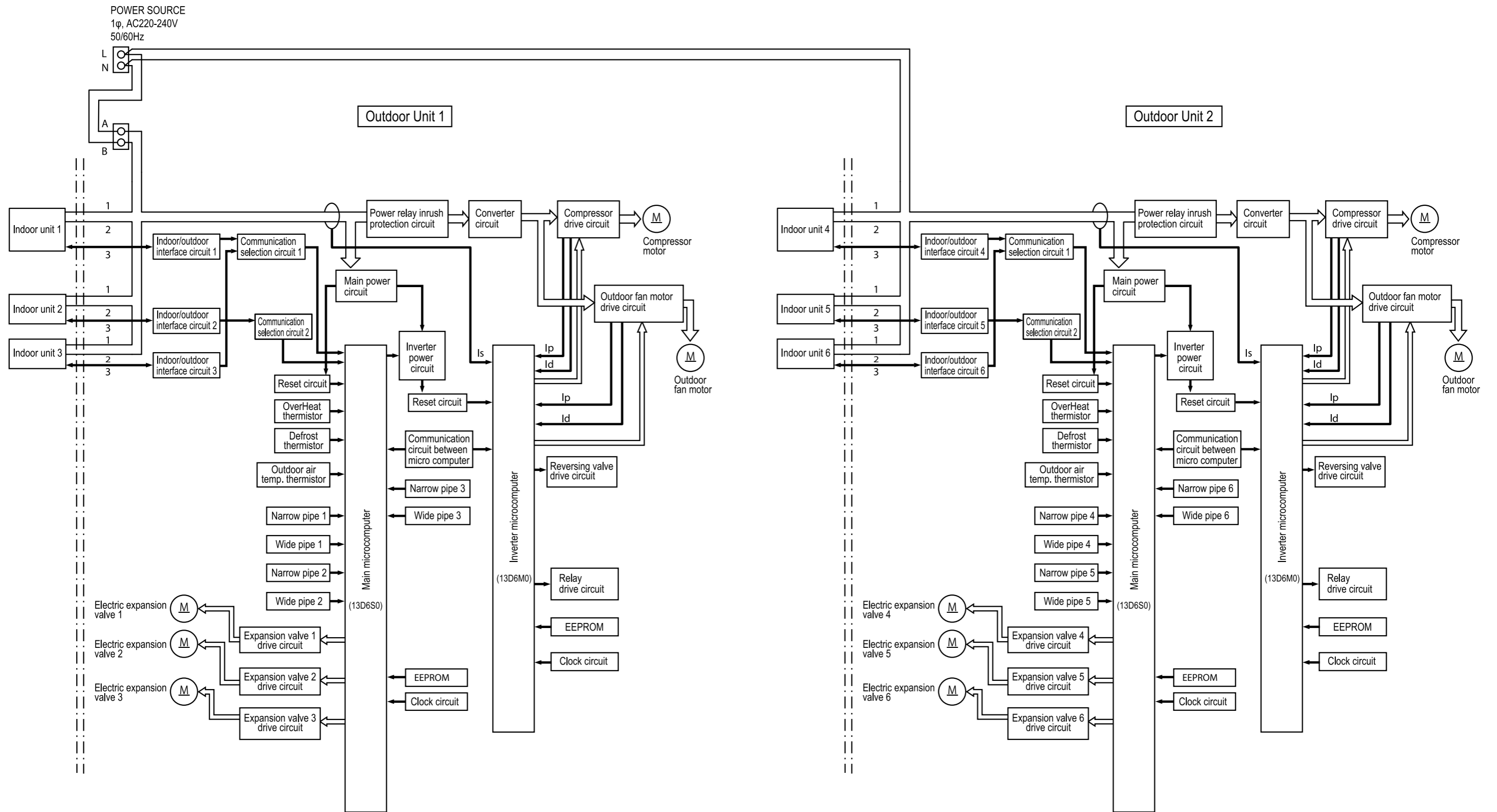

PRINTED WIRING BOARD LOCATION DIAGRAM

■ RAM-110NP6B

Main board [component side]

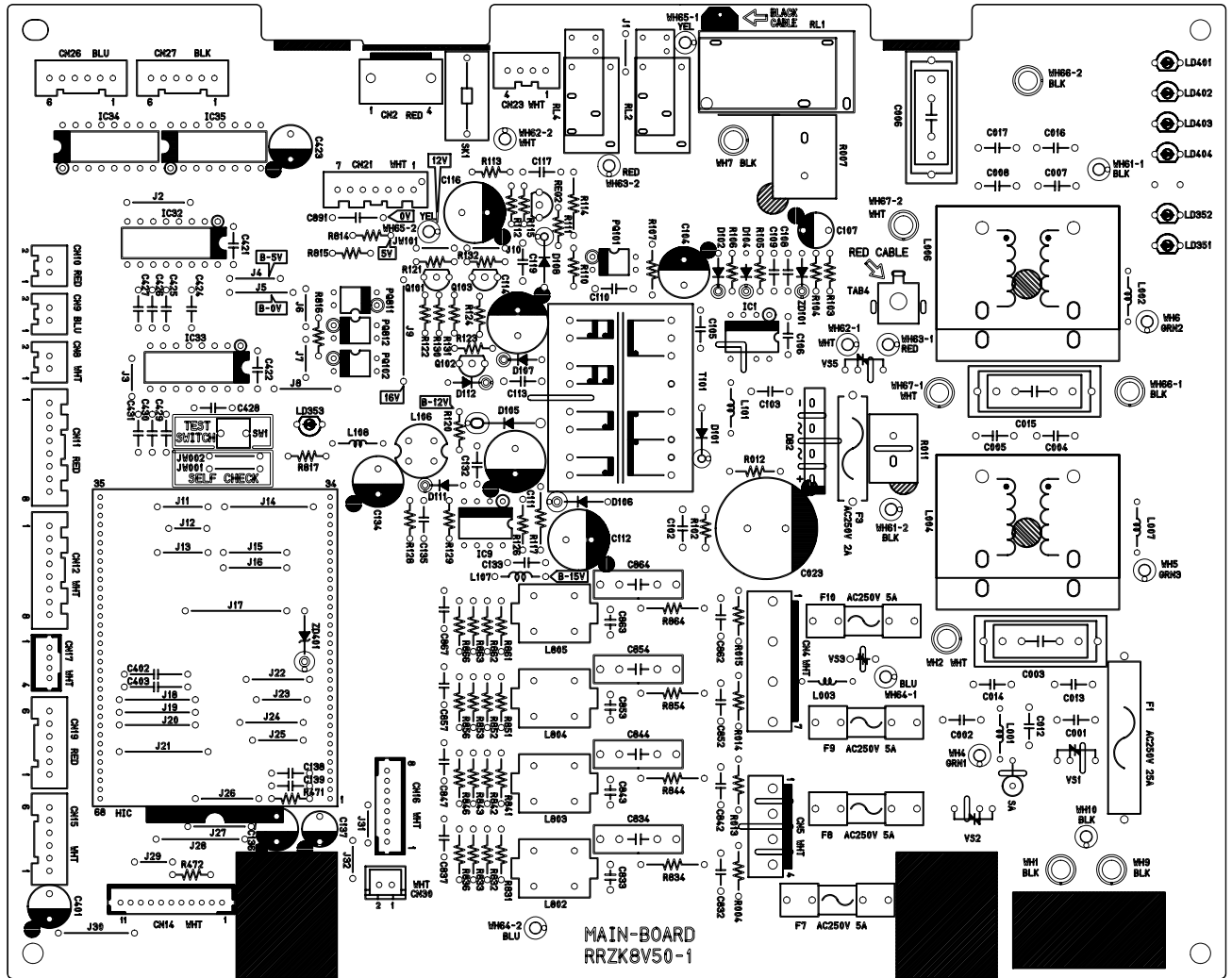

■ RAM-110NP6B

Inverter board [component side]

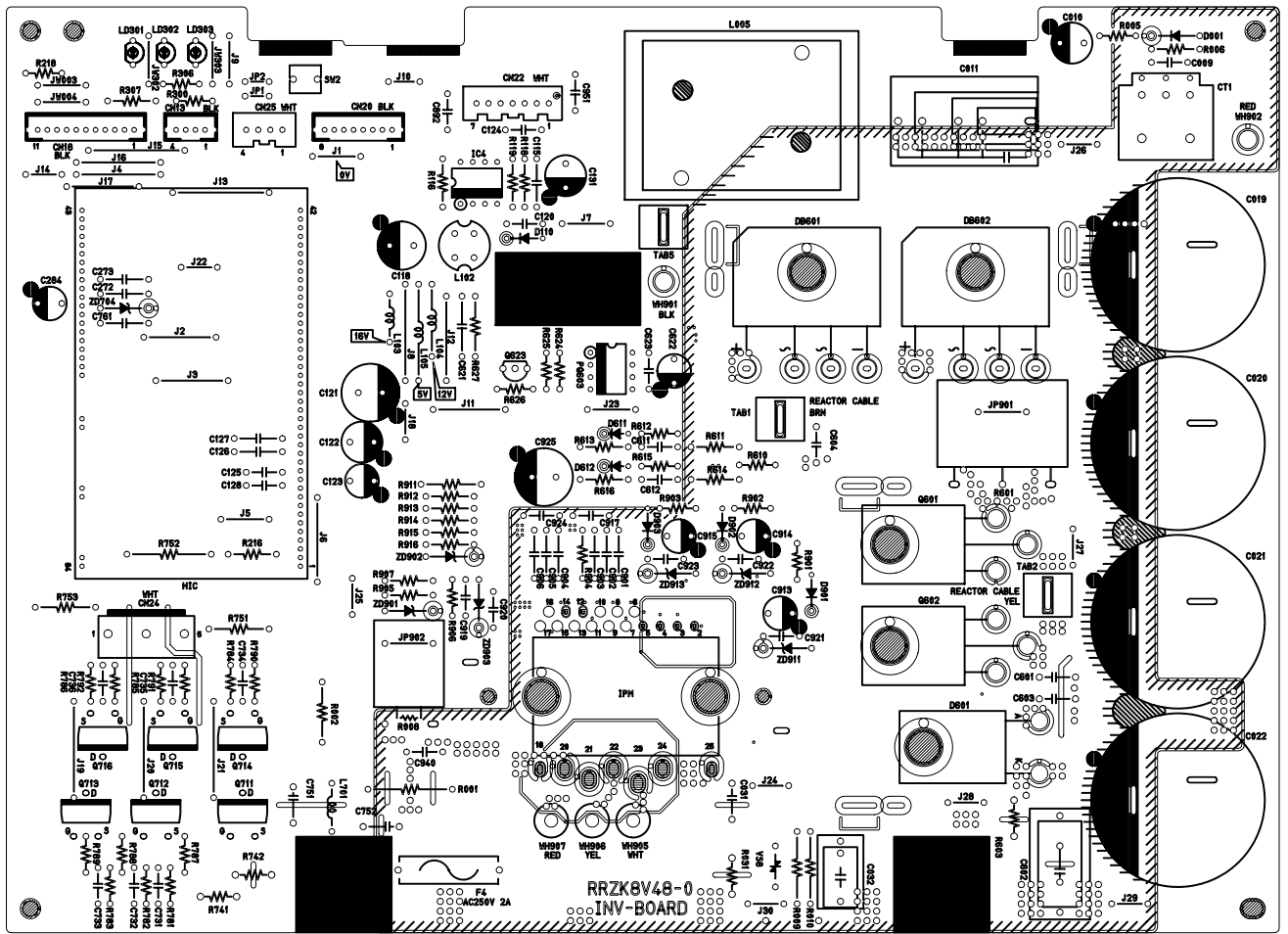

Inverter board [solder side]

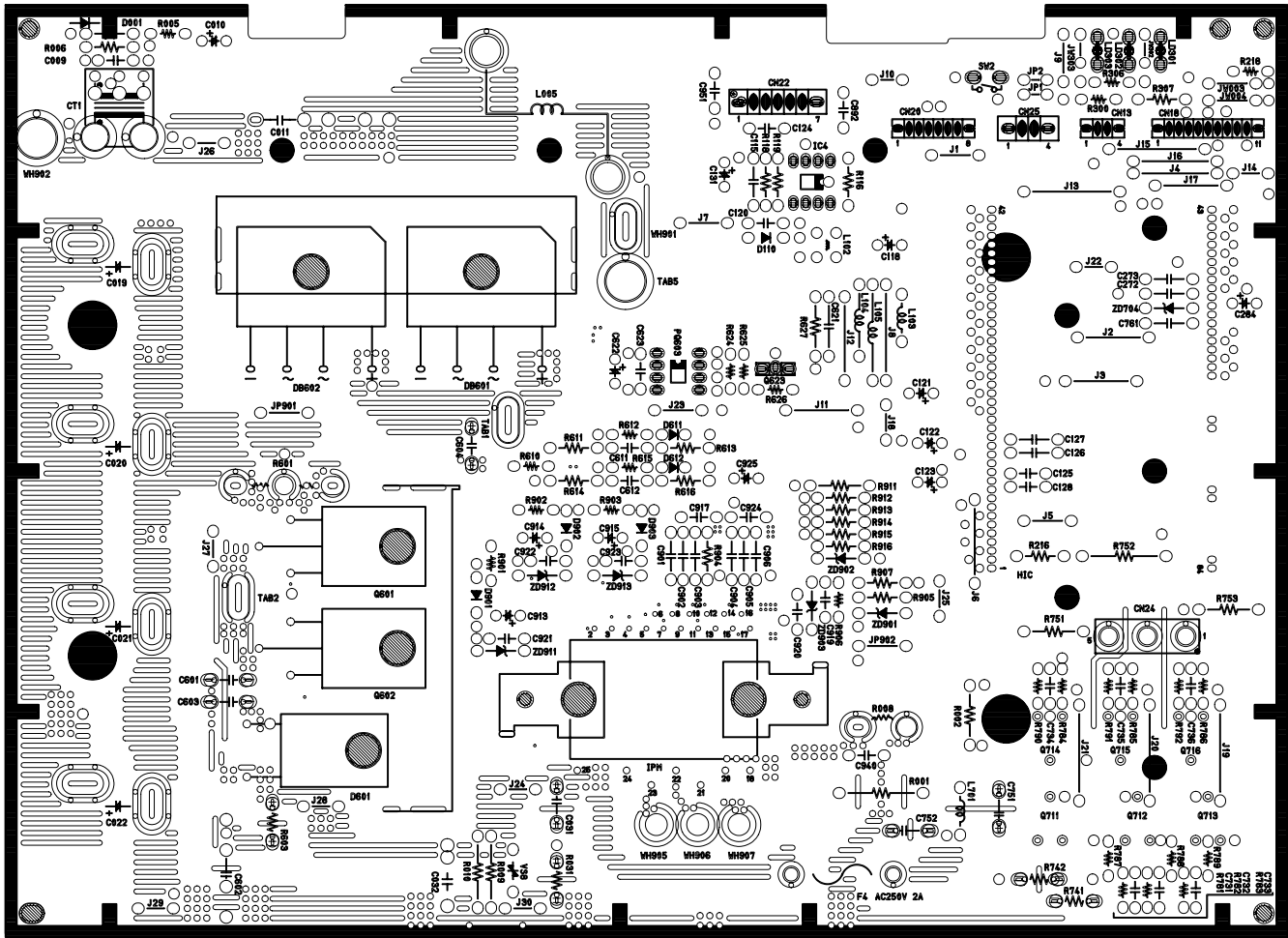

■ RAM-110NP6B

[Main HIC board] top side

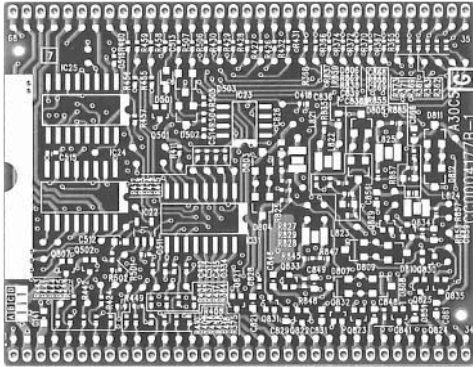

[Main HIC board] bottom side

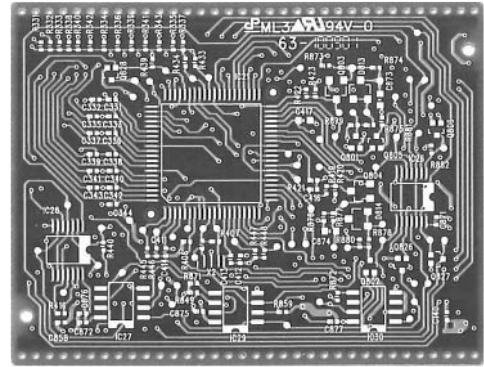

[Inverter HIC board] top side

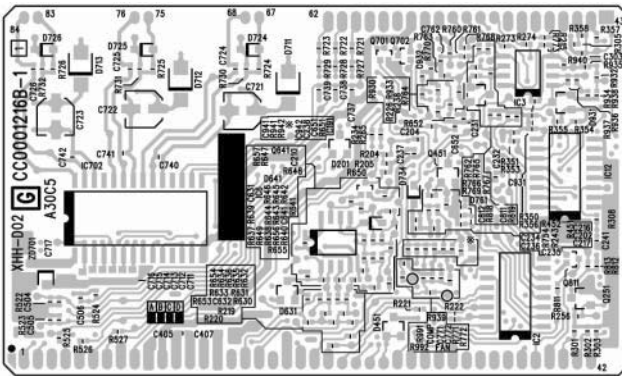

[Inverter HIC board] bottom side

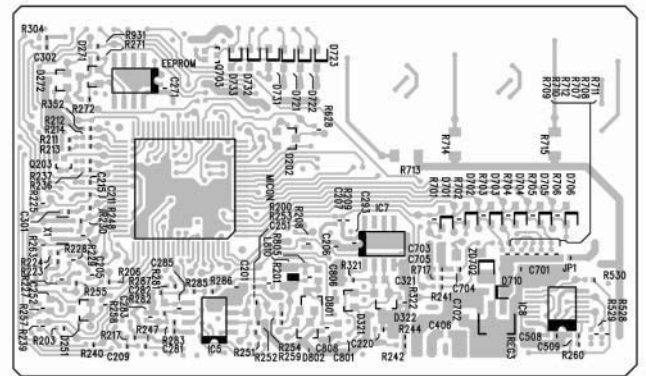

BASIC MODE

Operation mode		Fan	Cooling	Dehumidifying	Heating	Auto
Basic operation of start/stop button						
Timer functions	Off-timer					
	On-timer					
	Off -> On On -> Off timer					
Fan speed mode (indoor fan)	Auto	<p>Changes from "Hi" to "Med" or "Lo" depending on room temperature.</p> <ol style="list-style-type: none"> Runs at "Hi" until room temperature reaches to "setting temperature-SFTDSC_M" after operation is started. Runs at "ultra-Lo" when thermo is off. 	<p>Set to "ultra-Hi" when the compressor runs at cold dash mode speed, and to "Hi" in other modes. Runs at "ultra-Lo" when thermo is off.</p>	<p>Set to "ultra-Lo", "Silent", "Lo", "Med", "Hi", "ultra-Hi" or "stop" depending on the room temperature, time and heat exchanger temperature. Set to "stop" if the heat exchanger temperature is "DNZKOF_M" during Thermo OFF. (When reach at "DNZKON_M", fan speed set to "ultra-Lo" again.)</p> <p>Set to "ultra-Hi" when the compressor is running at maximum speed during hot-dash or when recovered from defrosting.</p>	<p>Operating mode is judged by room temperature.</p> <p>(1) Judging by room temperature</p> <ul style="list-style-type: none"> Operating mode at start up is judged (initial judgment). <p>(a) Conditions for judgment (any of the followings).</p> <ul style="list-style-type: none"> When auto operation is started after the previous auto mode operation. When auto operation is started after the previous manual mode operation. When the operating mode is switched to auto while operating at manual mode. <p>(b) Judging method</p> <ul style="list-style-type: none"> [Cooling] : Room temperature \geq Remote controller setting [Heating] : Room temperature $<$ Remote controller setting 	
	Hi	Operates at "Hi" regardless of the room temperature.	Set to "ultra-Hi" when the compressor runs at cold dash mode speed, and to "Hi" in other modes. Runs at "ultra-Lo" when thermo is off.	Set to "ultra-Lo", "Silent", "Lo", "Med", "Hi", "ultra-Hi" or "stop" depending on the room temperature, time and heat exchanger temperature. Set to "stop" if the heat exchanger temperature is "DNZKOF_M" during Thermo OFF. (When reach at "DNZKON_M", fan speed set to "ultra-Lo" again.)		
	Med	Operates at "Med" regardless of the room temperature.	Operates at "Med" regardless of the room temperature. Runs at "ultra-Lo" when thermo is off.	Set to "ultra-Lo", "Silent", "Lo", "Med", "Hi", "ultra-Hi" or "stop" depending on the room temperature, time and heat exchanger temperature. Set to "stop" if the heat exchanger temperature is "DNZKOF_M" during Thermo OFF. (When reach at "DNZKON_M", fan speed set to "ultra-Lo" again.)		
	Lo	Operates at "Lo" regardless of the room temperature.	Operates at "Lo" regardless of the room temperature. Runs at "ultra-Lo" when thermo is off.	Set to "Lo" in modes other than when the compressor stops.		
	Silent	Operates at "Silent" regardless of the room temperature.	Operates at "Silent" regardless of the room temperature. Runs at "ultra-Lo" when thermo is off.	Set to "Silent" in modes other than when the compressor stops.		
Basic operation of temperature controller	<p>Performs only fan operation at the set speed regardless of the room temperature.</p>	See page 41.	See page 43.	See page 45.		
Sleep operation (with sleep button ON)	<ul style="list-style-type: none"> Enters sleep operation after set as on the left. Action during sleep operation Lo (sleep) operation 	<ul style="list-style-type: none"> Same as at left See page 42. 	<ul style="list-style-type: none"> Same as at left See page 44. 	<ul style="list-style-type: none"> Same as at left See page 46. 	<ul style="list-style-type: none"> Same as at left. Performs the sleep operation of each operation mode. 	

SYSTEM 1 AND 2

PROM. ADD.	LABEL NAME	VALUE
000	PSTARTC1_d	250
001	PSTARTC1K_d	300
002	PSTARTC2_d	150
003	PSTARTC2K_d	300
004	PSTARTC3_d	150
005	PSTARTC3K_d	300
02E	DFCTPS_d	150
030	DFSPPS_d	10
031	BNTDFSP_8u	10
036	DFPSMX_d	400
03A	PCLOSH_d	86
13F	DFCTPS2_d	400
157	DFCTPS1U_d	230
159	DFCTPS2U_d	230
165	STAROTP_C	25.0
166	SDRCT1_C1	2500
167	TSKTM1_C1	60
168	SDRCT1_C2	2500
169	TSKTM1_C2	60
16F	SDSTEP	500
170	TSKSPT	30
184	CMAX2	5000
186	CMAX3	5700
19B	WMAX2S2U	5200
1AB	WMAX3S2U	5800
1AD	WMAX3S3U	6000
1BD	WMAX4S2U	6000
1BF	WMAX4S3U	6000
1C1	WMAX4S4U	6000
7A6	NDWN_ON	97.2
7A7	NDWN_OFF	95.0
85F	TDF414_1U	60
860	TDF414_2U	70
861	TDF414_3U	60
866	TDF415_1U	80
867	TDF415_2U	70
868	TDF415_3U	60
86D	SDRCT2	2000
86E	TSKTM2	70
86F	DFSTEP	500
870	TDFSPT	60
871	DEFMAX	4000
872	SDRCT2_2U	2300
873	TSKTM2_2U	45
874	DFSTEP_2U	700
875	TDFSPT_2U	40
876	DEFMAX_2U	6000
877	SDRCT2_3U	2500
878	TSKTM2_3U	60
879	DFSTEP_3U	800
87A	TDFSPT_3U	60
87B	DEFMAX_3U	6000
88C	T_DFCTPS	50
898	DEFOFF_1U	15.4
899	DEFOFF_2U	15.4
89A	DEFOFF_3U	15.4

Basic Cooling Operation

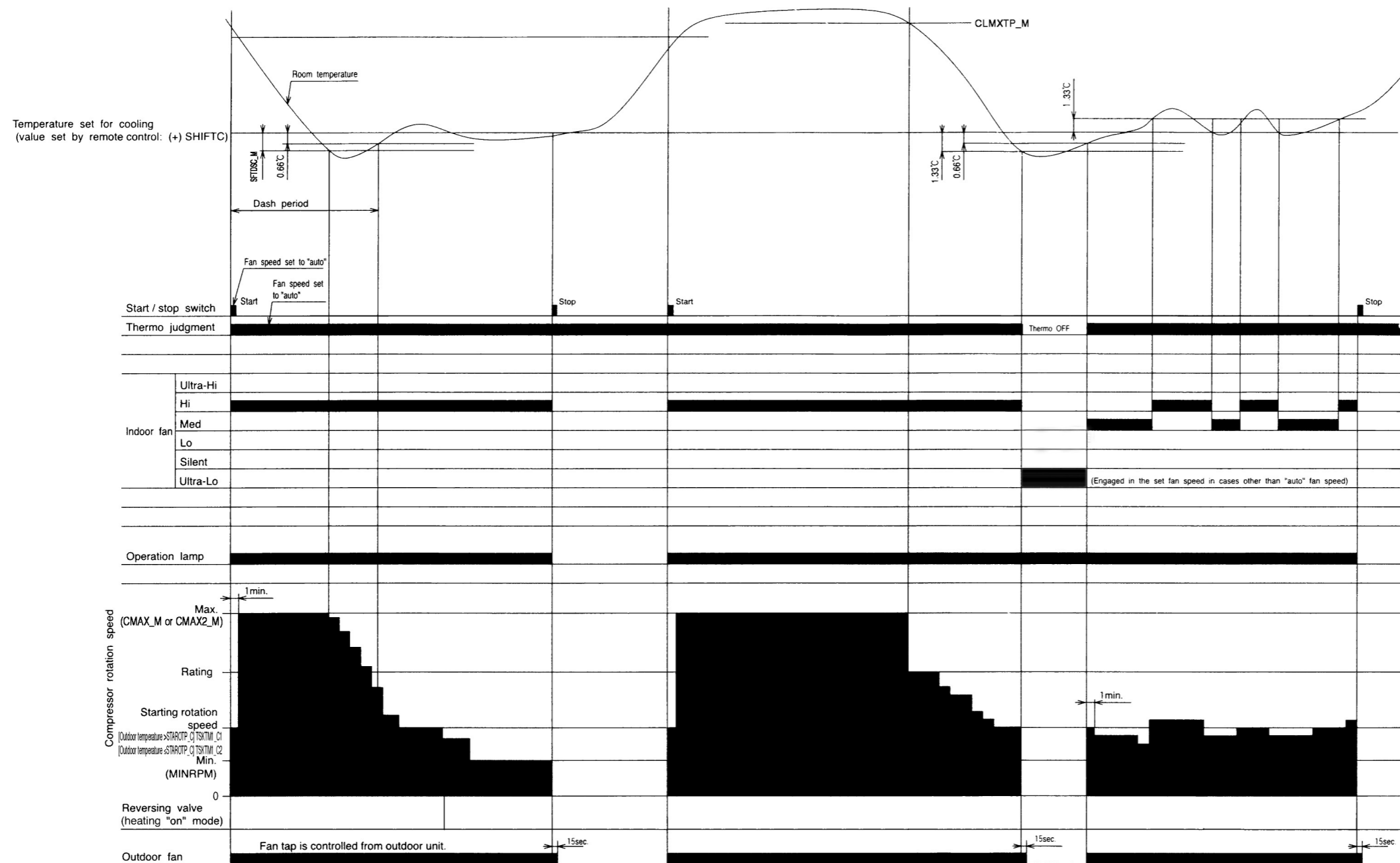

Notes:

- (1) Cool dash is started when the operation is started at fan speed "AUTO" or "HI" or when the fan speed is changed to "AUTO" or "HI" during cooling operation, and when the compressor speed (P item) reaches (C_{MAX_M} or C_{MAX2_M}) or higher.
- (2) The maximum compressor speed period during cool dash is finished.
 - 1 When 25 minutes have elapsed after cool dash was started.
 - 2 When the room temperature reaches the cooling set temperature -1°C (including cooling shift) and then becomes lower than the preset temperature by 0.66°C after the steady speed period
 - 3 When thermo is OFF.
(If cool dash finished in the above 1, the compressor does not go through the steady speed period but it starts fuzzy control.)
- (3) The thermo OFF temperature during cool dash is cooling set temperature (including cooling shift) -3°C. After thermo OFF, cool dash is finished and fuzzy control starts.
- (4) The compressor minimum ON time and minimum OFF time is 3 minutes.
- (5) The time limit for which the maximum compressor speed (C_{MAX_M} or C_{MAX2_M}) during normal cooling can be maintained is less than 60 minutes when the room temperature is less than CLMXTP_M: it is not provided when the room temperature is CLMXTP_M or more.
- (6) Compressor speed is determined by instruction sent from indoor unit and corrected by outdoor unit according to such factors as capacity, fan speed, number of units being operated, outdoor temperature, discharge pressure and etc.
- (7) If another indoor unit is doing heating operation, cooling operation cannot be done.

Cooling Sleep Operation

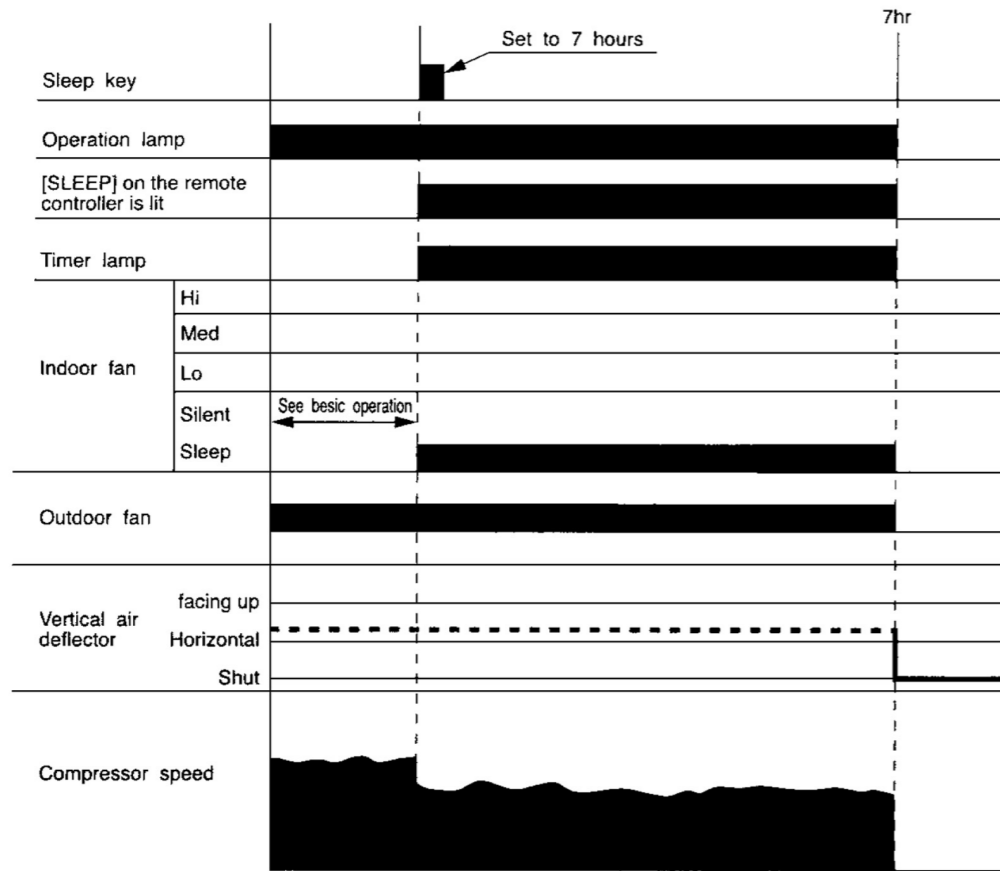

Notes.

- (1) The sleep operation starts when the sleep key is pressed.
- (2) When the sleep key is set, the indoor fan is set to "sleep silent" (FCSOY_M).
- (3) The indoor fan speed does not change even when the fan speed mode is changed.
- (4) If the set time is changed during sleep operation, all data including set temperature, time, etc. is cleared and restarted.
- (5) If sleep operation is canceled by the cancel key or sleep key, all data is cleared.
- (6) If the position of air deflector is being operated using remote control, the operation will be performed at any desired position of air deflector.

Cooling Defrost

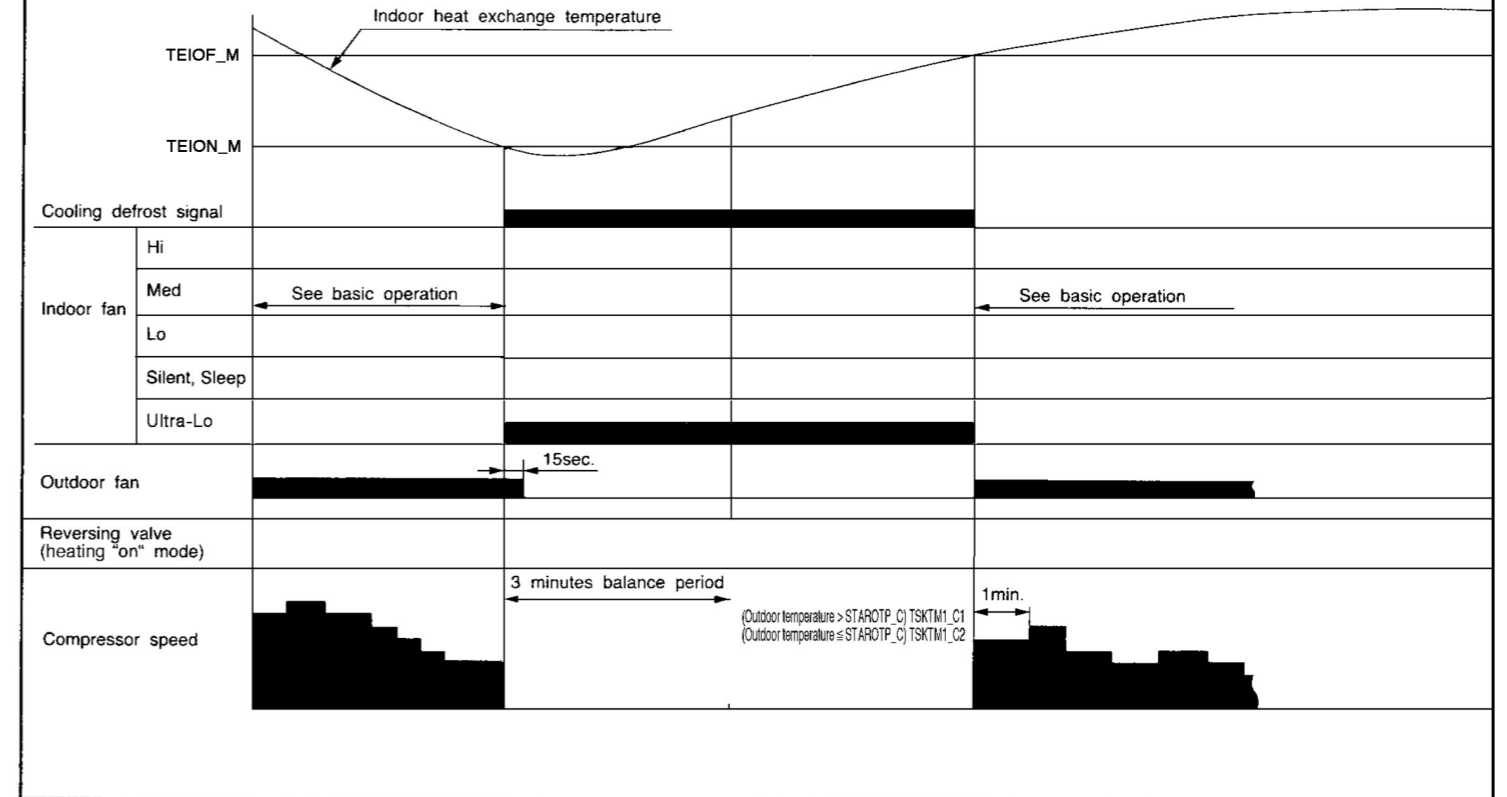

Dehumidifying

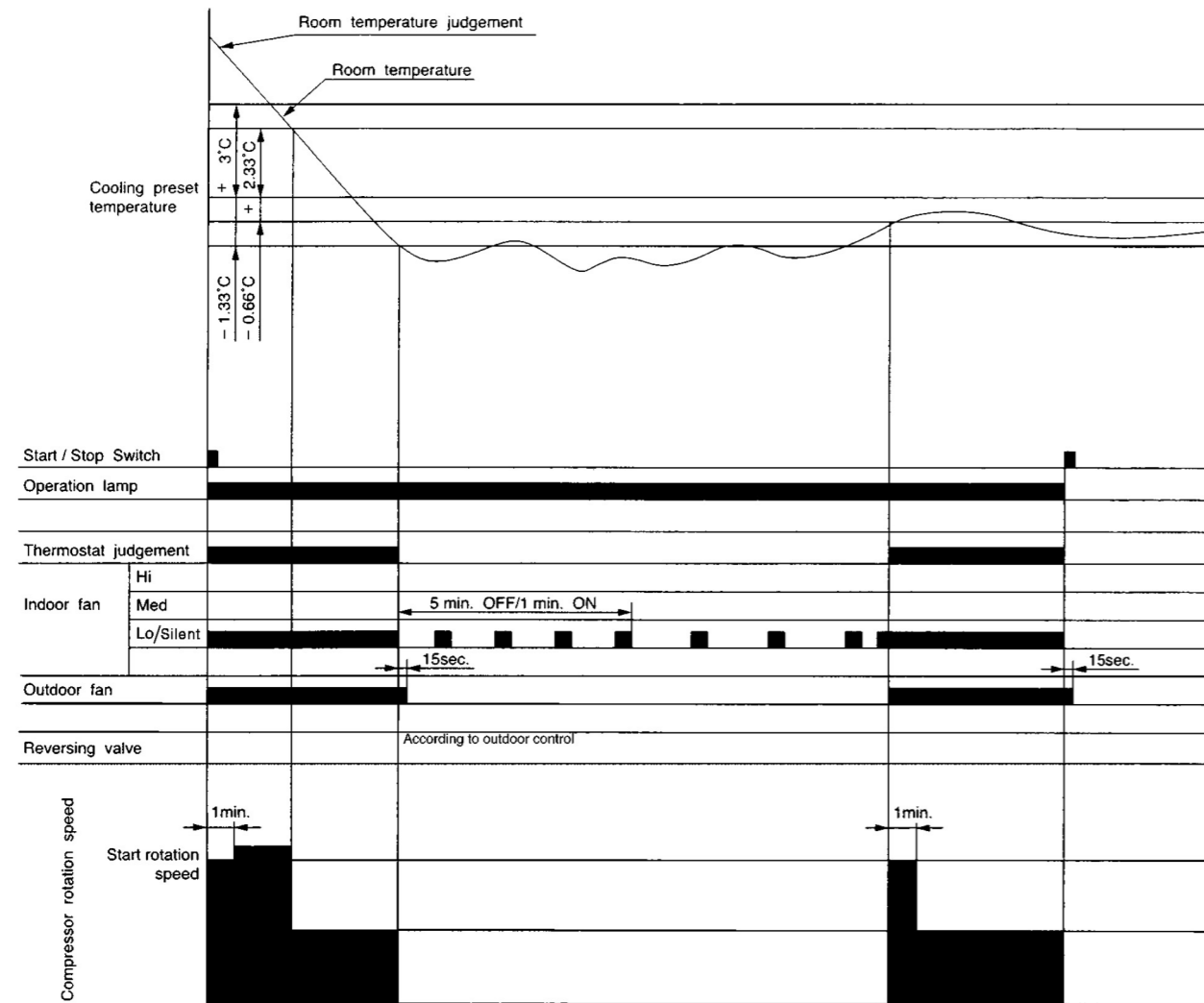

Notes:

- (1) The indoor fan is operated in the "Lo" or "Silent" mode, OFF for 5 minutes and ON for 1 minute, repeatedly according to the humidity judgement when the thermostat is turned OFF.
- (2) The compressor is operated forcedly for 3 minutes after operation is started.
- (3) The minimum ON time and OFF time of the compressor are 3 minutes.
- (4) At the start of operation, the thermostat will be off when room temperature \leq setting temperature -1.33°C ; the thermostat will be on when room temperature \geq setting temperature -0.66°C .
- (5) The following procedure is performed to prevent excessive cooling during operation other than start. However, this procedure applies only when the thermostat is intermittent:
 - Whether THERMO ON is to continue or not depends on the thermal condition when the 3-minute forced operation ceases.
 - ① "THERMO ON continues" when room temperature \geq setting temperature $+1^{\circ}\text{C}$: (The THERMO operation value is usually the same as that at "start of operation")
 - ② "Forced THERMO OFF" when room temperature $<$ setting temperature $+1^{\circ}\text{C}$: (The same THERMO operation value as that at "start of operation" is usually used for recovery)
 Therefore, if the air-conditioner is stabilized under this thermal condition, it will enter intermittent operation, which is "3-minute operation/3-minute stop".
- (6) Compressor speed is determined by instruction sent from indoor unit and corrected by outdoor unit according to such factors as capacity, fan speed, number of units being operated, outdoor temperature, etc.

Dehumidifying Sleep Operation

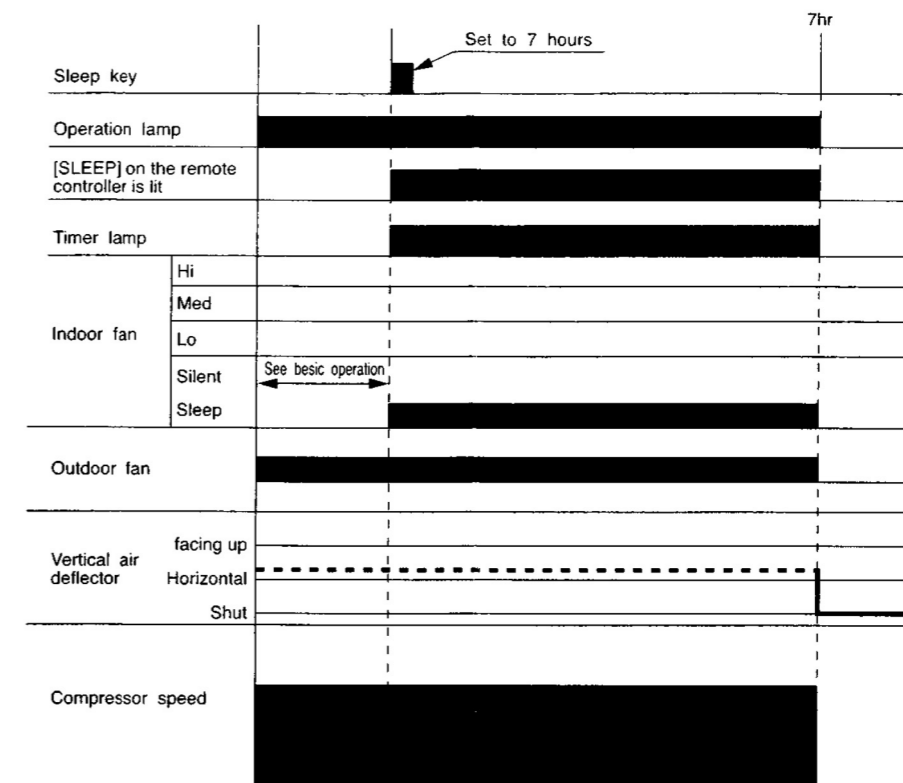

Notes:

- (1) The sleep operation starts when the sleep key is pressed.
- (2) When the sleep key is set, the indoor fan is set to "sleep silent" (FDOY_M).
- (3) The indoor fan speed does not change even when the fan speed mode is changed.
- (4) If the set time is changed during sleep operation, all data including set temperature, time, etc. is cleared and restarted.
- (5) If sleep operation is canceled by the cancel key or sleep key, all data is cleared.
- (6) If the position of air deflector is being operated using remote control, the operation will be performed at any desired position of air deflector.

Basic Heating Operation

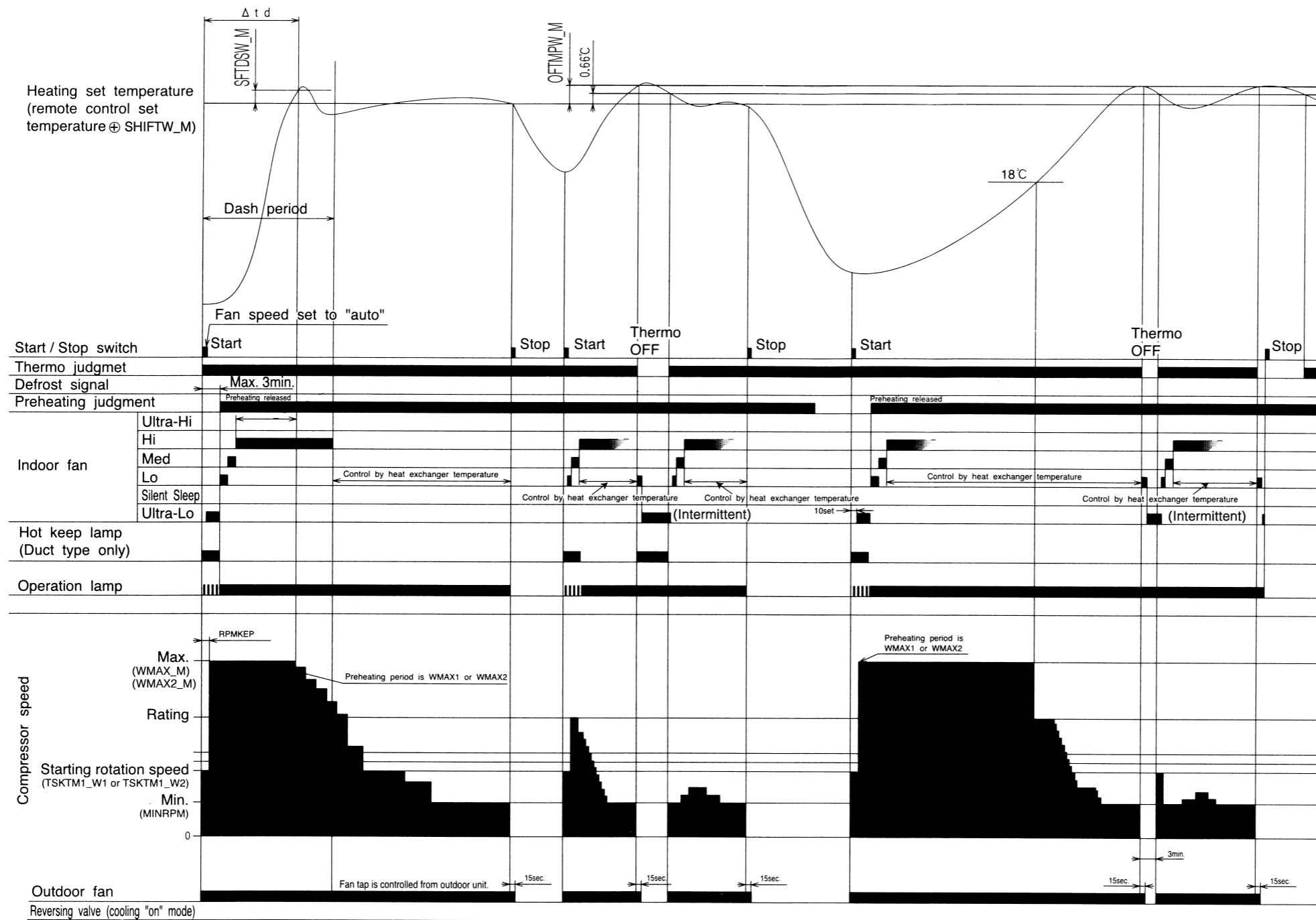

Notes:

- (1) Hot Dash is started when the operation is started at fan speed "AUTO" or "HI" or when the fan speed is changed to "AUTO" or "HI" during heating operation, and when the compressor speed (P item) reaches (WMAX_M or WMAX2_M) or higher with the room temperature at 8°C or less and outdoor temperature at 10°C or less.
- (2) The maximum compressor speed period during hot dash is finished (1) when the room temperature reaches the heating set temperature (including heating shift) plus SFTDSW_M or (2) when the thermo is off.
- (3) The thermo OFF temperature during hot dash is heating set temperature (including heating shift) plus 3°C. After thermo OFF, hot dash finishes, and PI control starts.
- (4) The compressor minimum ON time and minimum OFF time is 3 minutes.
- (5) The time limit for which the maximum compressor speed (WMAX_M or WMAX2_M) during normal heating (except for hot dash) can be maintained is less than 120 minutes when the room temperature is 18°C or more; it is not provided when the room temperature is less than 18°C and outdoor temperature is less than 4°C.
- (6) The operation indicator will blink every second during initial cycle operation, preheating, defrosting (including balance time after defrost is finished), or auto fresh defrosting. However, with duct type models, operation indicator does not blink, but Hot Keep indicator will light. And Hot Keep indicator will also light in "Thermo OFF" mode.
- (7) For preheating judgment, preheating starts if the heat exchange temperature is lower than YNEOF_M and is cancelled if the heat exchange temperature is YNEOF_M plus 0.33°C or higher at the start of operation using the START/STOP button.
- (8) If the room temperature falls to less than 18°C in the "Ultra-Lo" mode, the indoor fan stops. When the room temperature is 18°C+0.33°C or more, the ultra-Lo operation restarts. However, the ultra-Lo operation during preheating or preheating after defrosting does not stop if the room temperature is less than 18°C.
- (9) Compressor speed is determined by instruction sent from indoor unit and corrected by outdoor unit according to such factors as capacity, fan speed, number of units being operated, outdoor temperature, discharge pressure etc.
- (10) If another indoor unit is doing cooling operation, dehumidifying operation or fan operation, heating operation cannot be done.
- (11) Indoor fan will reduce 1 step lower if heat exchanger thermistor sense lower temperature than default setting. Indoor fan resume to initial setting once heat exchanger thermistor sense above than default setting.

Heating Sleep Operation

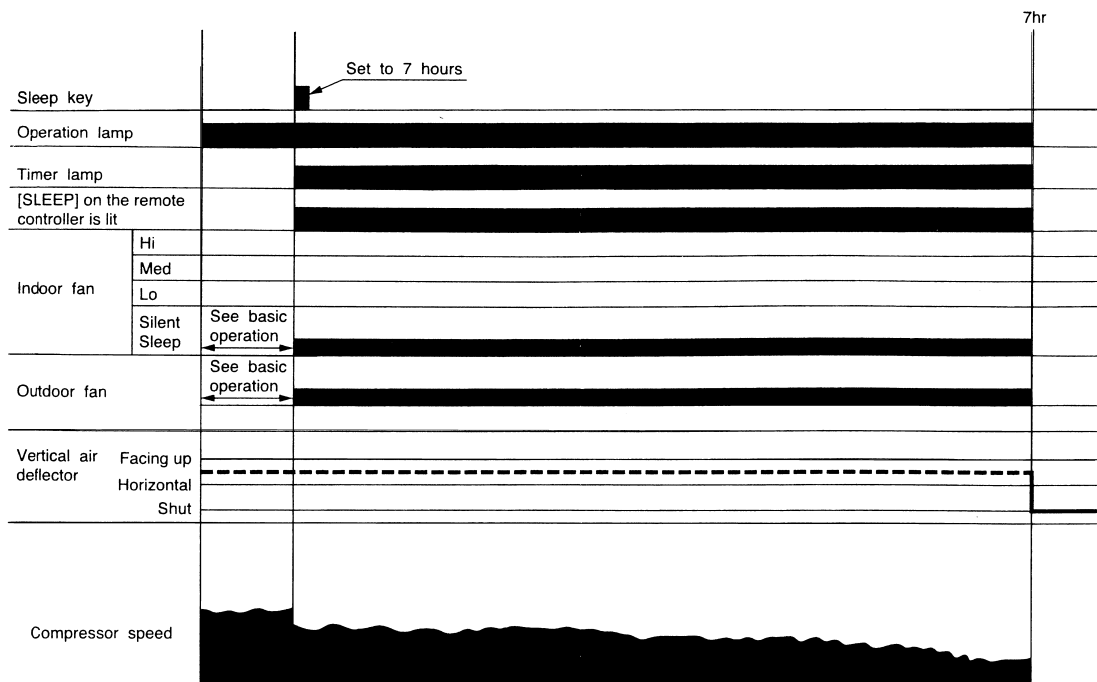

Notes:

- (1) The sleep operation starts when the sleep key is pressed.
- (2) When the sleep key is set, the indoor fan is set to "Sleep Silent" (FWSOY_M or AFWSOY).
- (3) The indoor fan speed does not change even when the fan speed mode is changed.
- (4) When defrosting is to be set during sleep operation, defrosting is engaged and sleep operation is restored after defrosting.
- (5) If the set time is changed during sleep operation, all data including set temperature, time, etc. is cleared and restarted.
- (6) If sleep operation is canceled by the cancel key or sleep key all data is cleared.
- (7) If the position of air deflector is being operated using remote control, the operation will be performed at any desired position of air deflector.

NOTE:

1. Refer to the PWRITE-ZU data for the constats expressed by capital alphabet letters in the drawing.

MODEL RAM-110NP6B

EXPANSION VALVES

The expansion valves are initialized when power is supplied. The valve for unit 1 is fully closed (-520 pulses), and then that for unit 2 is fully opened (480 pulses). The valve for unit 2 is fully closed (-520 pulses), and then that for unit 3 is fully opened (480 pulses). The valve for unit 3 is fully closed (-520 pulses). When the valve for unit 1, 2, 3, is fully closed (0 pulse), start-up is possible.

The start openings are held during the steady speed period when the compressor is started. After the steady speed period is finished, the TD control is entered. The start openings are set to $PSTARTC * K_d$ when the outdoor temperature at start $40^{\circ}C$ or more, and to $PSTARTC * _d$ when it is less than $40^{\circ}C$.

* Indicate number of operating indoor unit

Compressor rotation speed

When the compressor is started, it will be in steady speed period.
The compressor speed and duration during steady speed period is as below:

COMP Speed (min ⁻¹)	Duration (sec)	Outdoor Temperature (°C)
SDRCT1_C1	TSKTM1_C1	> STAROTP_C
SDRCT1_C2	TSKTM1_C2	≤ STAROTP_C

After the steady speed period is finished, the speed increases at the rate of $SDSTEP$ (min⁻¹) within $TSKSPT$ (sec) until the target speed is reached.

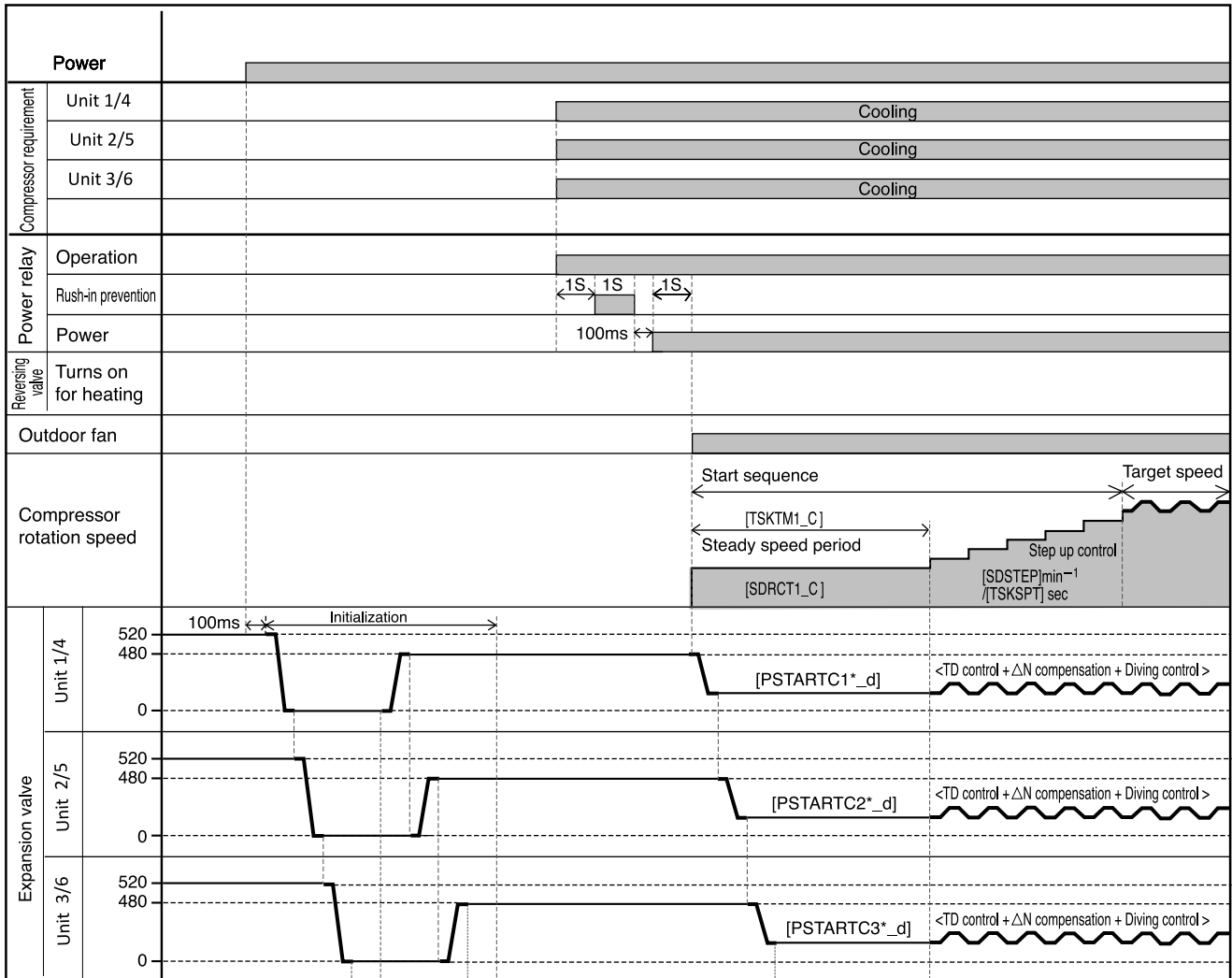

DEFROST

Reversing valve defrost system is employed: it consists of balancing period → reversing cycle period → balancing period.

(1) Defrost start condition

- When all the following conditions are established defrost is executed:
 - ① Normal operation
 - ② Heat exchange temperature is within defrost range specified by outdoor temperature and heat exchange temperature. (Defrost signal occurred).
 - ③ Defrost inhibit period linked to outdoor temperature has elapsed.

(2) Defrost release condition

- If any of the following conditions is established, defrost is released:
 - ① Heat exchange temperature returns (heat exchange temperature ≥ DEFOFF).
 - ② Defrost max time of 12 minutes has elapsed.
- Released by condition ① during balancing period: When remaining balancing period has elapsed, returned to initial condition (ASTUS = 0).
- Released by condition ① or ② during reverse cycle period: [TDF415_*U] shifted to balancing period.

(2) Output during defrost

- Indoor defrost request: Transmitted to all units being operated in heating mode.
- Compressor: Balancing period for [TDF414_*U] (min-1) → Starting of reverse cycle period by [SDRCT2] (min-1) for [TSKTM2] (sec) → Accelerating by [DFSTEP](min-1) for duration [TDFSP](sec) in remaining reverse cycle period until defrost MAX speed [DEFMAX] is reached → Balancing period for [TDF415_*U](sec).
- Electric expansion valve
 - Unit being stopped : [FULL CLOSE] 30sec after balancing period has passed → [FULL CLOSE] during reverse cycle period → [PCLOSH_d] 15 sec before balancing period is finished.
 - Unit being operated : [DFCTPS_d] 30sec before balancing period is finish → Synchronized with step-up of rotation speed of compressor, opened by [DFSPPS_d] pulse and reaches MAX opening degree [DFPSMX_d] when rotation speed of compressor reaches [DEFMAX]

* indicate number of operating indoor unit

RAM-110NP6B DEFROST TEMPERATURE

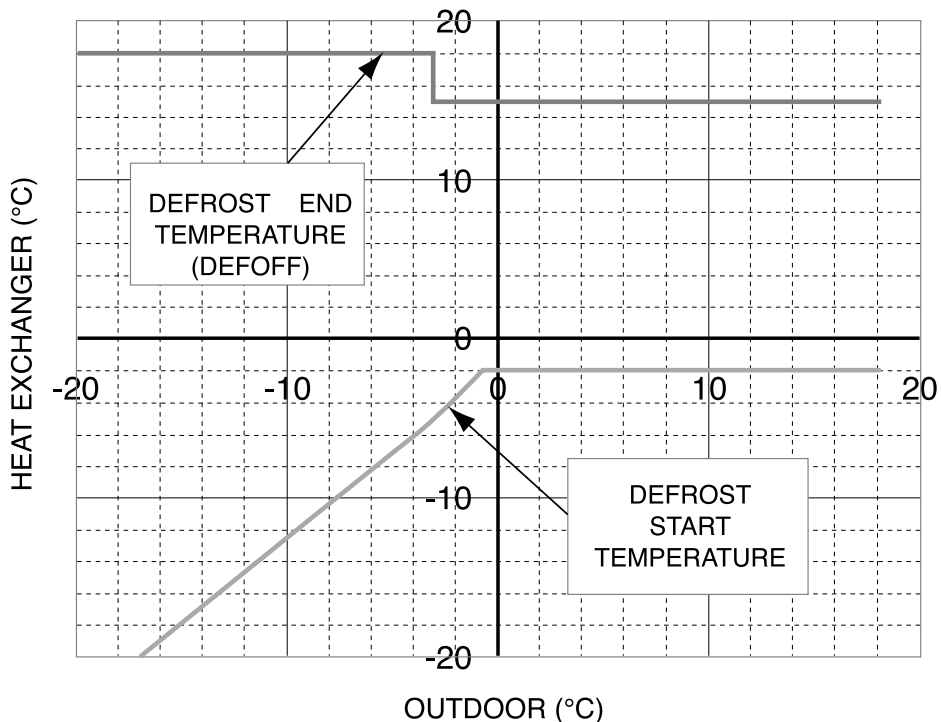

- * above graph is showing the ideal value by micon program.
- * guaranteed temperature range of this model is -15°C to +21°C at heating.

AUTO-FRESH DEFROST

• During heating operation is stopped, and when auto-fresh condition is established, defrost operation will be performed while operation is stopped.

Auto-fresh consists of balancing period at start of defrost for [TDF414_*U] seconds → Reverse cycle period for MAX 12 minutes.

(1) Start conditions for auto-fresh

- When all the following conditions are established, auto-fresh is executed:
 - ① Defrost request signal is present.
 - ② All indoor units are stopped.
 - ③ 15 minutes of auto-fresh inhibit period has elapsed.
 - ④ Compressor is ON when operation is stopped.
 - ⑤ Compressor delay command is sent from indoor unit when operation is stopped.

(2) Release condition of auto-fresh

- If any one of following conditions is established, auto-fresh is released:
 - ① Heat exchange temperature returns (heat exchange temperature ≥ DEFOFF)
 - ② 12 minutes of defrost MAX time has elapsed.
 - ③ Failure occurred.
 - ④ Either unit or unit 2 or unit 3 or unit 4 or unit 5 or unit 6 started operation.
- ※ Released during start of balancing period : Stopped or started after remaining balancing period has elapsed.
- Released during reverse cycle period : Stopped or started after balancing for 3 minutes.

(3) Outputs during auto-fresh

[Indoor unit defrost request]: Transmitted only to unit to which auto-fresh is applied (indoor unit stopped last).

[Compressor]: Accelerated by DFSTEP min⁻¹/TDFSPT seconds and reaches defrost MAX speed [DEFMAX].

[Electric expansion valve]:

Unit auto-fresh not applied: FULL CLOSE when balancing for 30 seconds has elapsed at start of defrost.

Unit auto-fresh applied : Synchronized with step-up of rotation speed of compressor, opened by [DFSPPS_d] pulses and reaches MAX opening degree [DEFPSMX_d] when rotation speed of compressor reaches [DEFMAX].

(4) Note

- Shifted to auto-fresh in defrost mode when operation is stopped.
- All indoor units must be stopped to fulfill condition for auto-fresh.
- If signal is delayed, auto-fresh condition will not be established.

MODEL RAM-110NP6B

* Indicate number of operating unit.

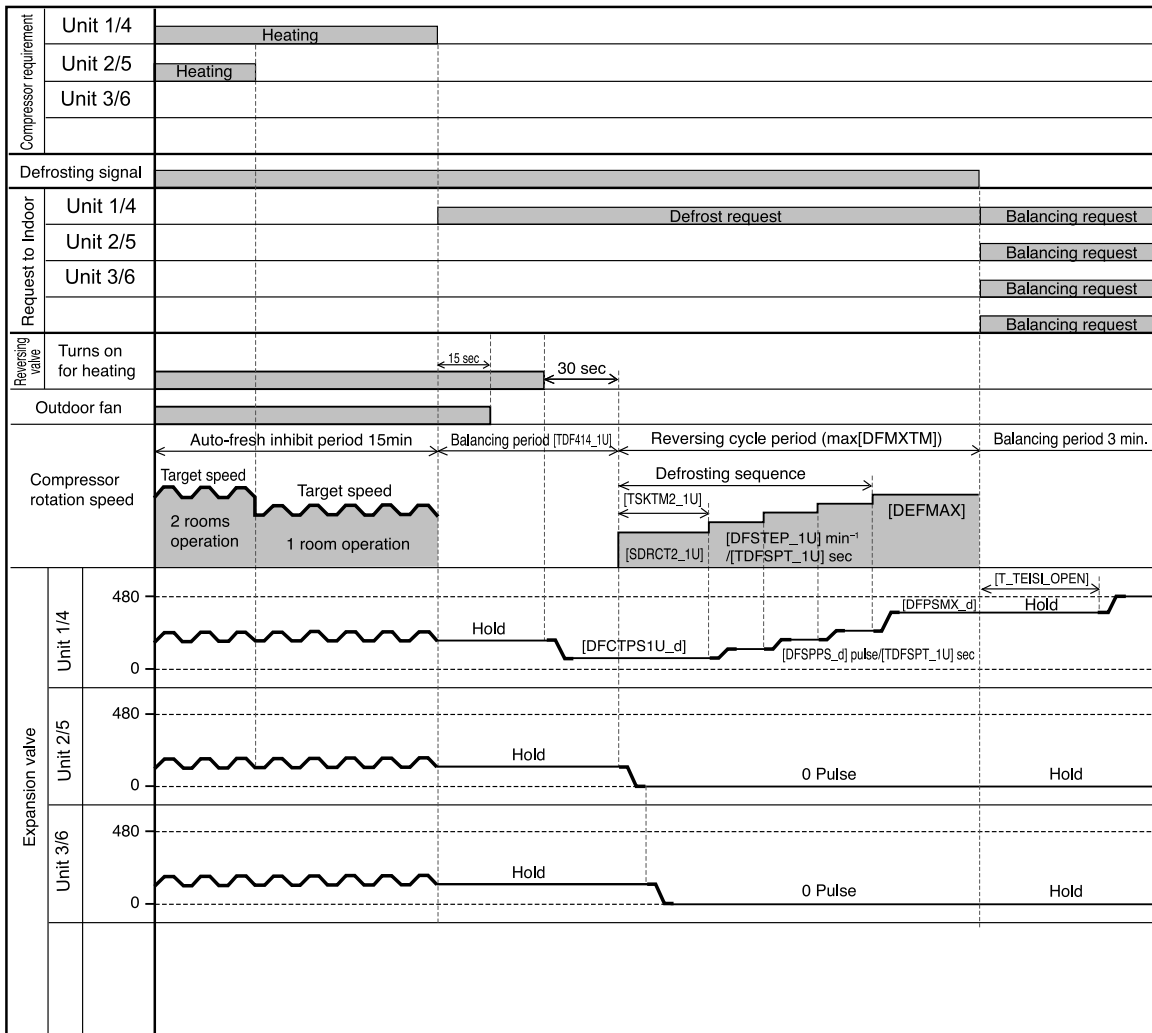

MODEL RAM-110NP6B

FORCED COOLING

• In order to accumulate refrigerant, units operate in cooling cycle.

Execution condition and operation status are shown below.

[Execution condition]

- With neither indoor unit 1,2,3,4,5 and 6 not operated, when forced cooling switch is turned ON, forced cooling will be performed.
- Always operation status of indoor units are monitored and forced cooling is inhibited when operation of any unit is detected.

[Operation status]

- Outdoor unit fan: Fixed in LO.
- Compressor rotation speed: Fixed in 3000min⁻¹.
- Expansion valve/reversing valve : Set in normal conditions.

[Note]

- During forced cooling, if failure occurs in outdoor unit, thermostat is turned off. However, it is not counted.
- Since rotation speed of compressor is fixed in 3000min⁻¹ during forced cooling, steady speed period of compressor at start is not performed.

• The following shows the operation state of forced cooling.

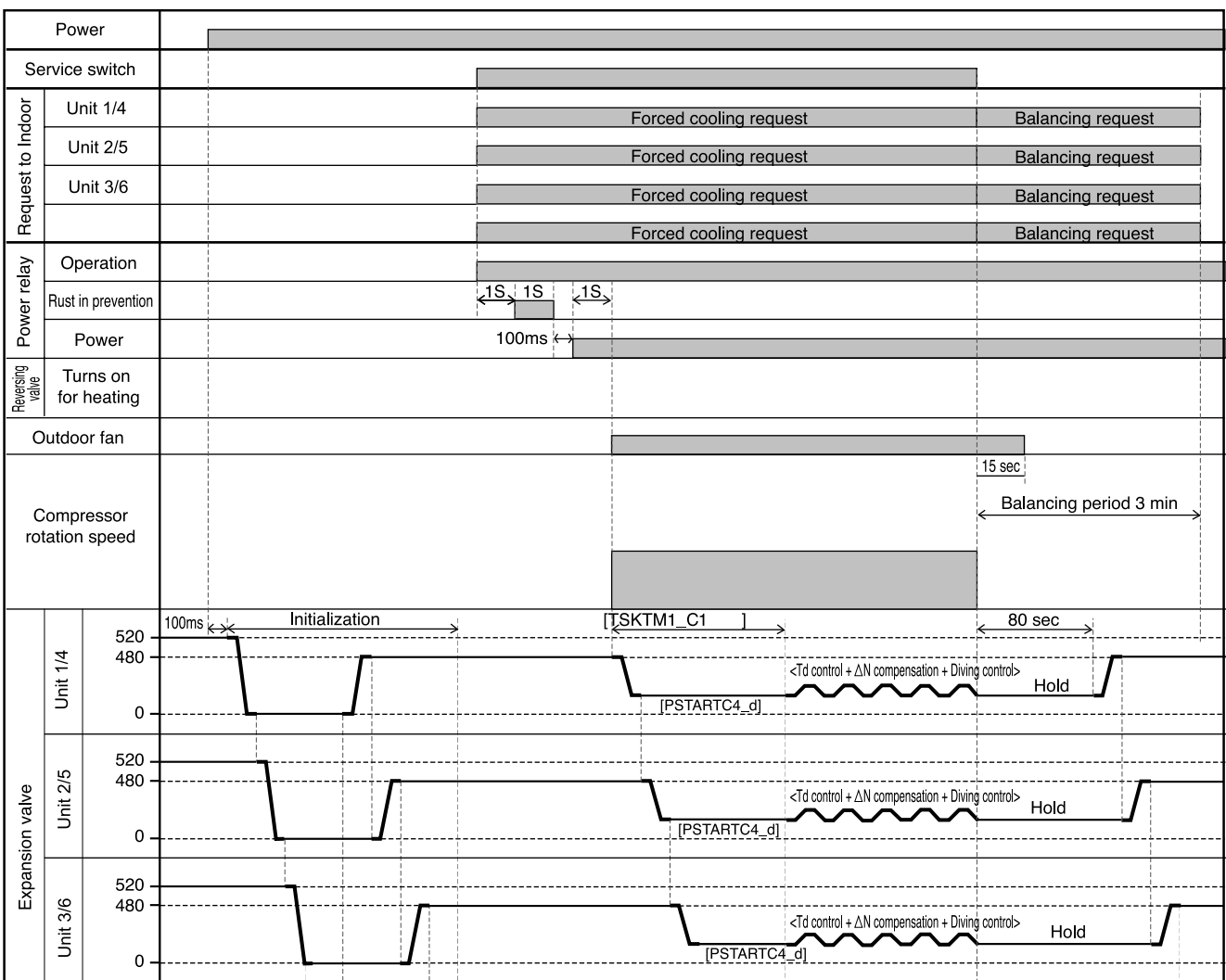

※ TSKTM1_C and PSTARTC2\$ are EEPROM data.

MODEL RAM-110NP6B

PROCESSING AT OVERHEAT THERMISTOR (OH) HIGH TEMPERATURE

◇ Restriction Start Conditions

- If any expansion valve is operated at 480 pulses and the OH temperature > [NDWN_ON], the compressor speed will be reduced at a rate of 100 min⁻¹/30 seconds.
- This reduced rotation speed is based on the speed when the reduction started, and will be maintained until the reduction is finished. However, the reference speed will be exchanged only if the target speed is lower than the speed when the reduction started.
- If [NDWN_OFF] ≤ OH temperature ≤ [NDWN_ON] and the OH temperature does not rise from that 20 seconds before, the reduction of compressor speed will not occur.

◇ Restriction Release Condition (in common for all)

- The restriction will be released when OH temperature < [NDWN_OFF], and the compressor speed will be increased at a rate of 50 min⁻¹/30 seconds to restore the target speed.

When one unit is operated for cooling

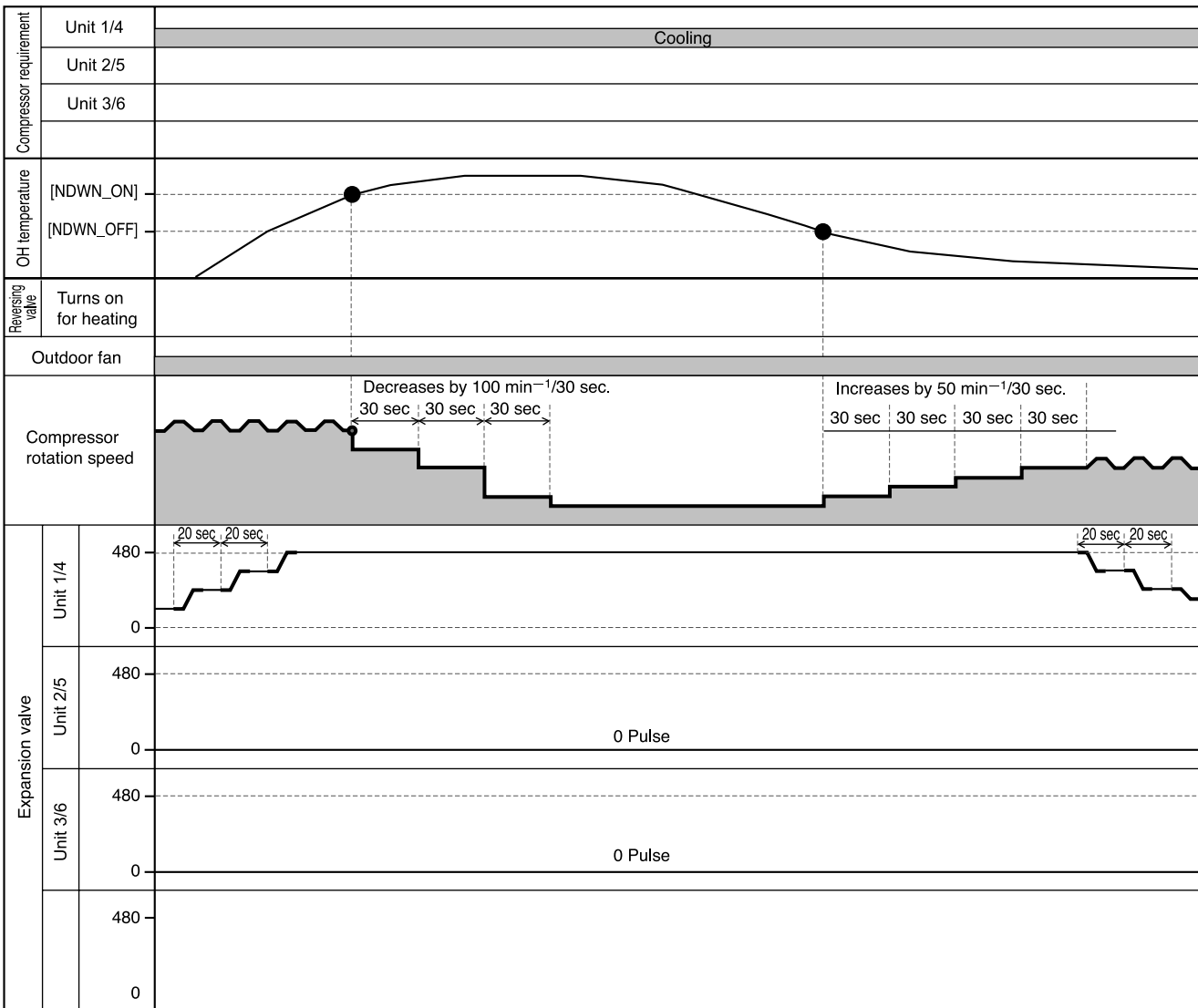

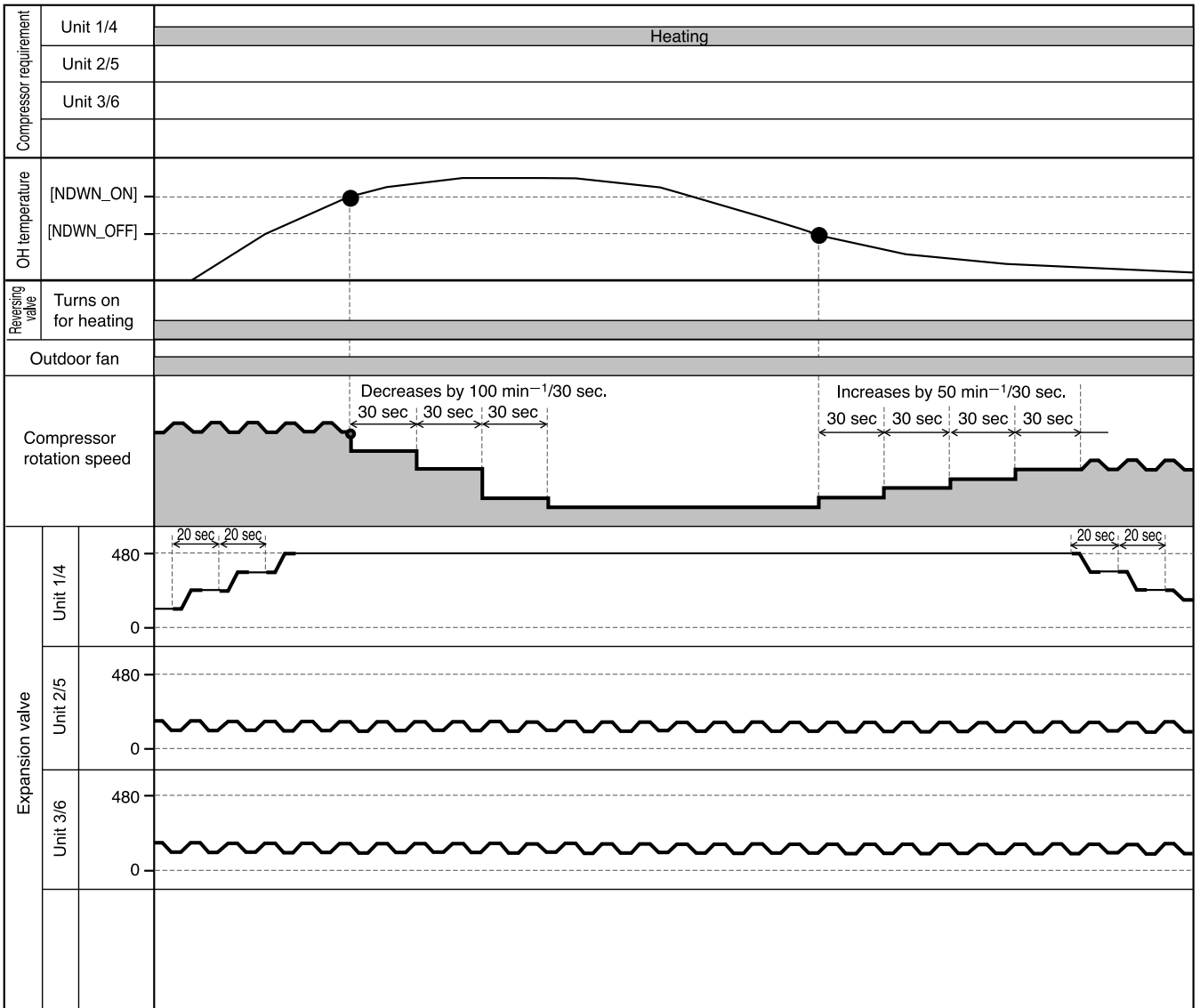

REFRIGERATING CYCLE DIAGRAM RAM-110NP6B

Cooling, Dehumidifying, Defrosting

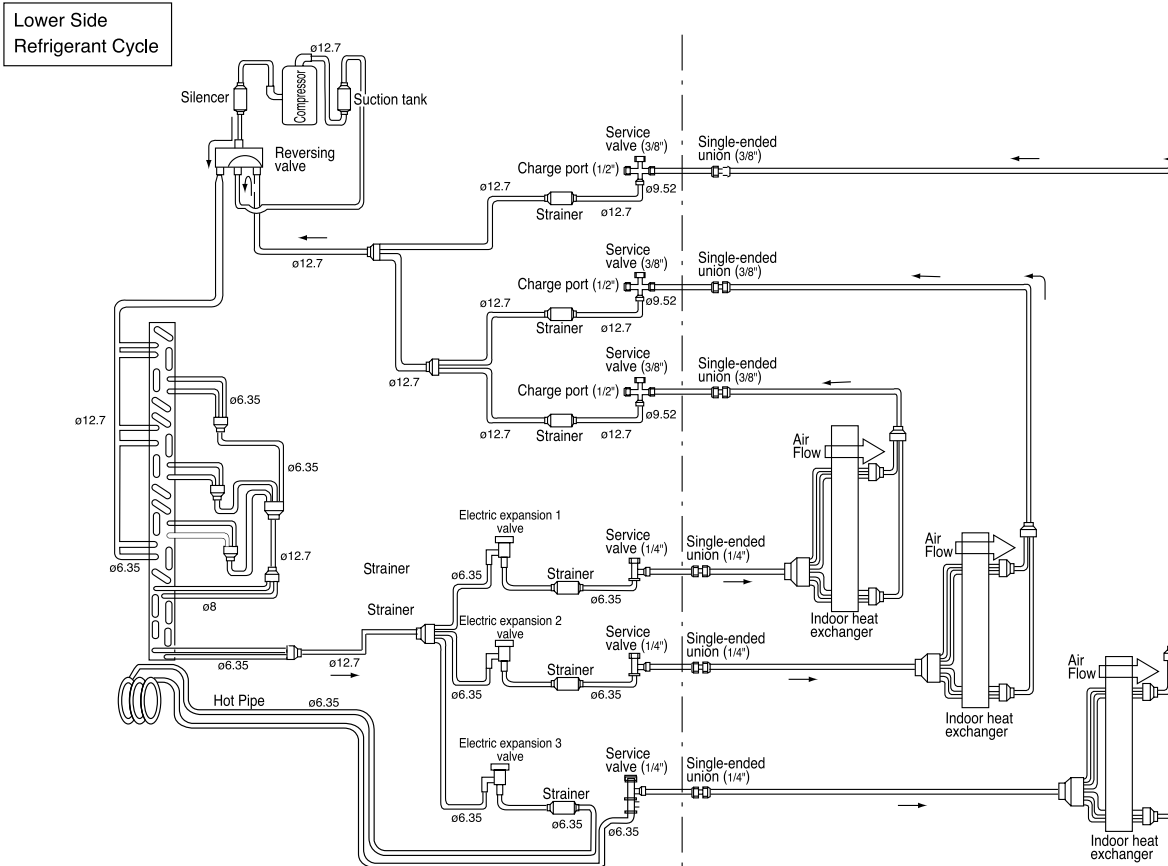
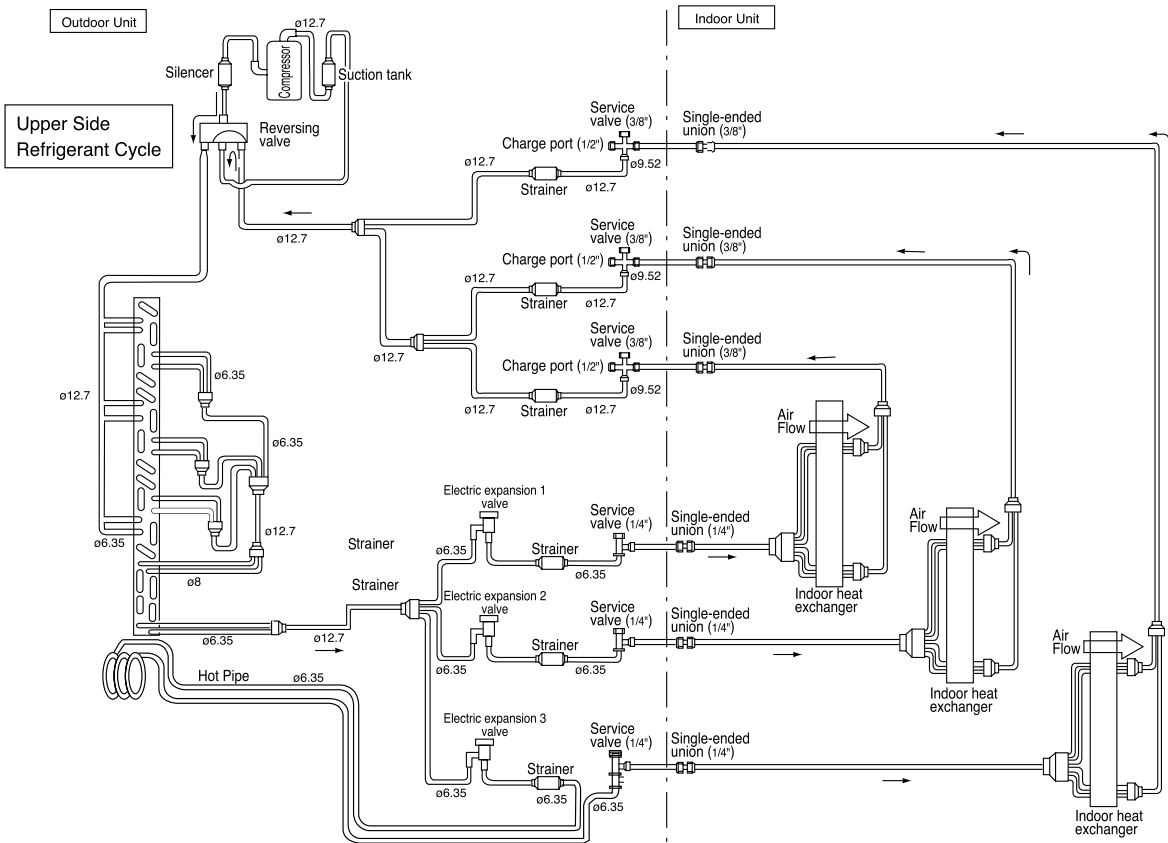

REFRIGERATING CYCLE DIAGRAM RAM-110NP6B

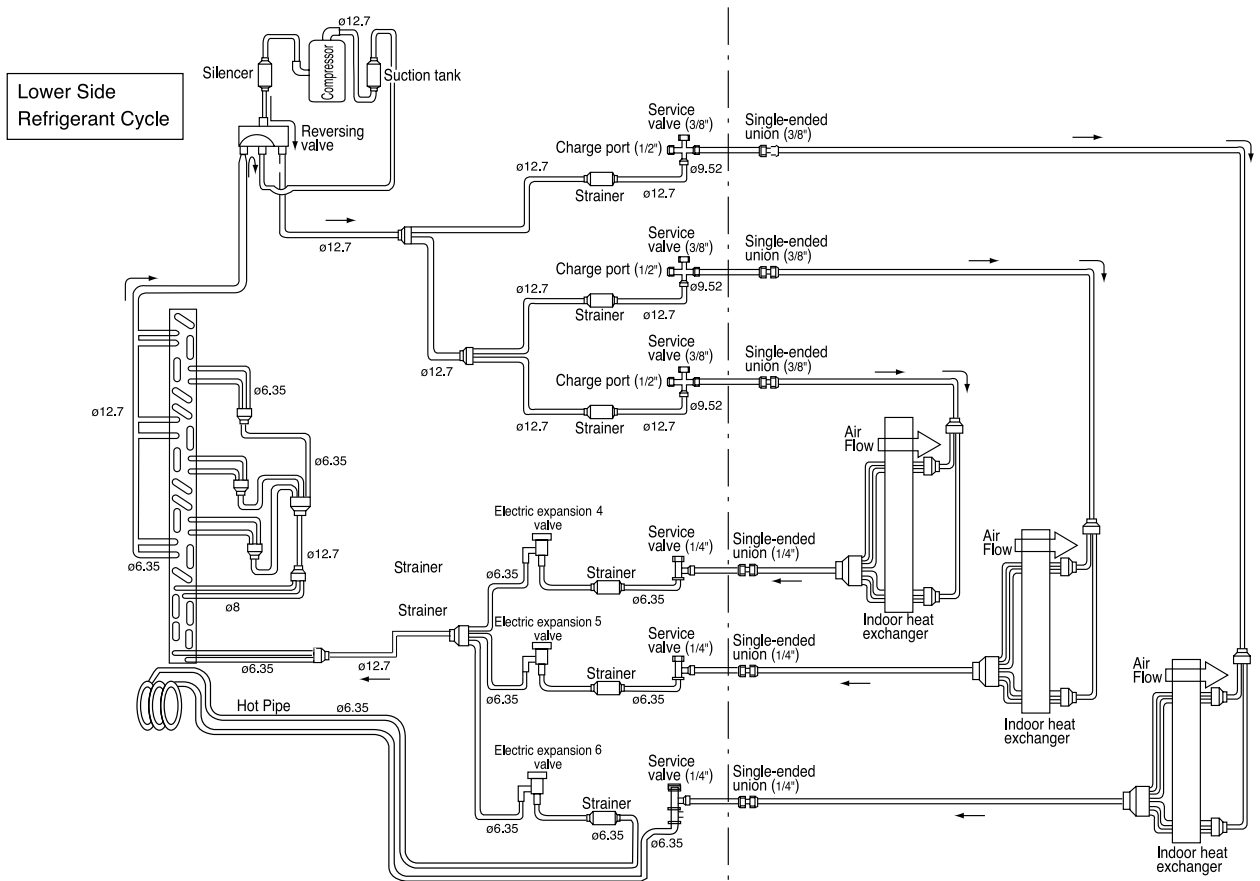
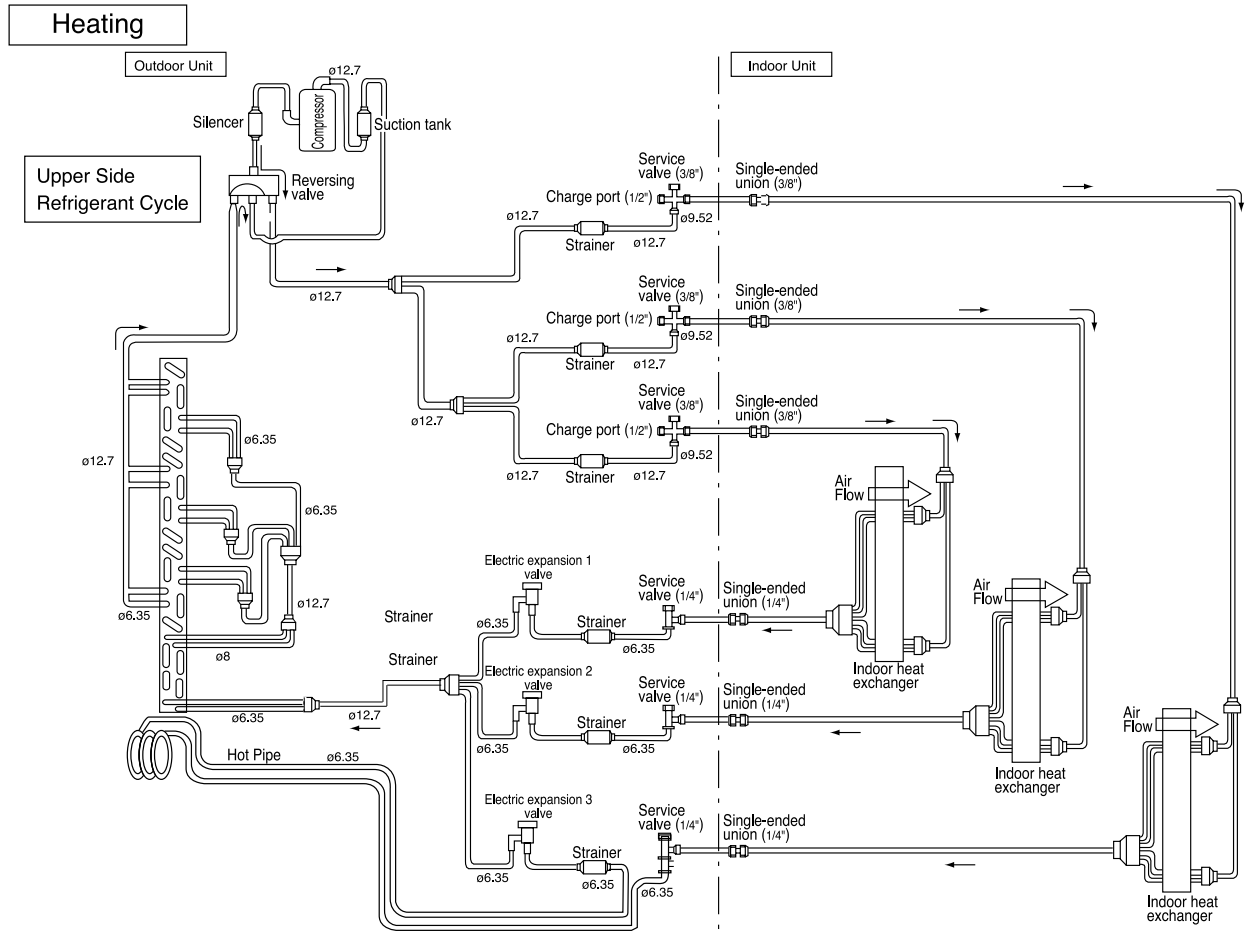

DESCRIPTION OF MAIN OPERATION CIRCUIT

■ RAM-110NP6B

1. Main Power Supply Circuit

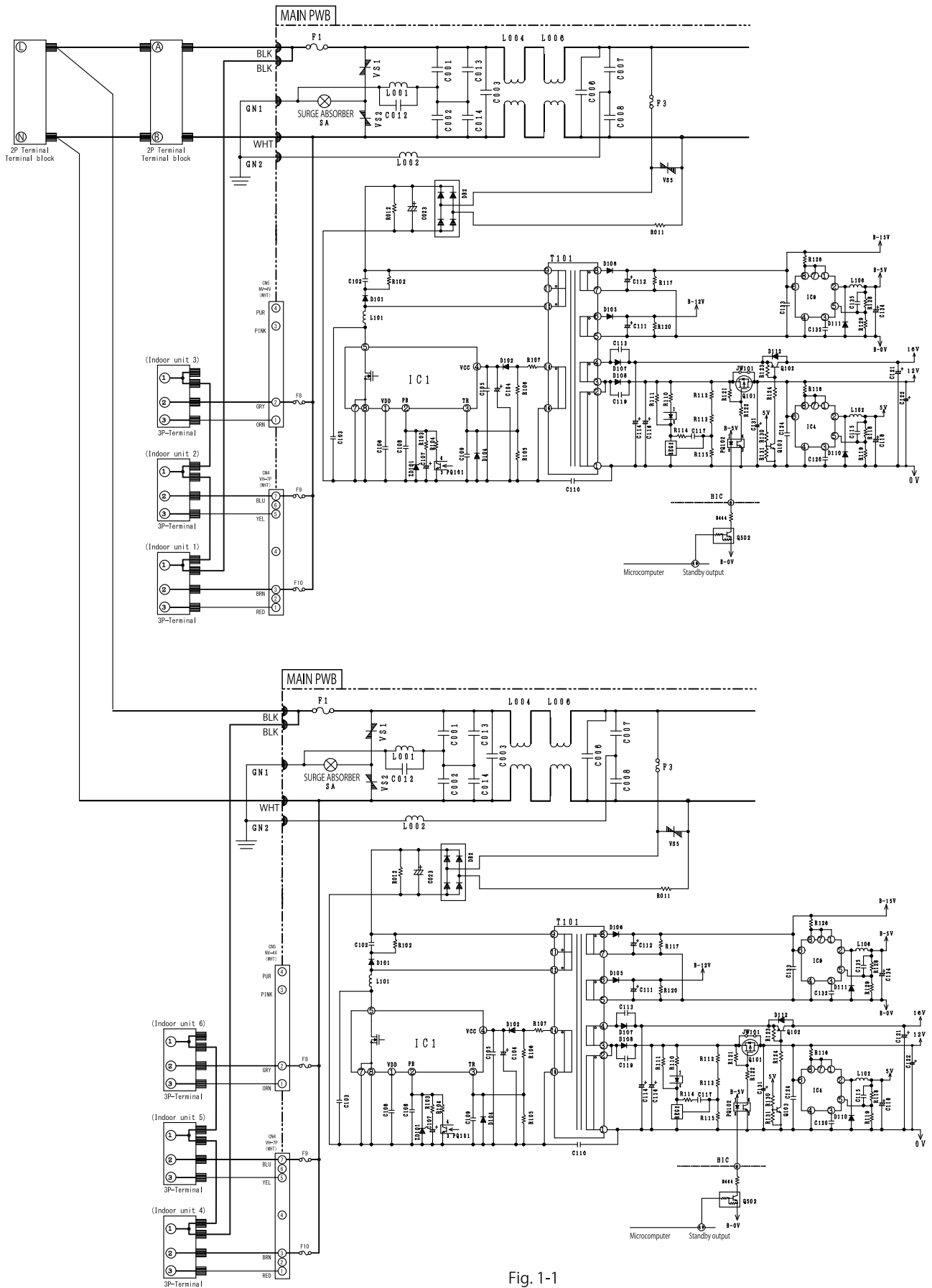

Fig. 1-1

- AC 220~240V power supplied to the 2P terminal block is supplied to DB2 via the noise filter circuit, 2A fuse (F3), and varistor (VS5). High-voltage DC smoothed by DB2 and C023 is used to create DC voltage on the transformer's secondary side by the switch control IC (IC1) and switching transformer.
- Secondary side DC voltage is used in the following six systems:
 - (1) B-15V : Power supply for communication circuits between outdoor and indoor
 - (2) B-5V : Power supply for main microcomputer and peripheral circuits
 - (3) B-12V : Operating power supply for electric expansion valve
 - (4) 16V : Power supply for compressor motor drive IPM and fan motor drive IPM
 - (5) 12V : Power supply for reversing valve relay, power relay, in-rush current relay, and operating amplifier for compressor motor and fan motor current amplification
 - (6) 5V : Power supply for inverter microcomputer and peripheral circuits
- Primary Components
 - (1) C001, C002, C012, C013, C014, C007, C008, L004, L006
Absorb electrical noise generated during operation of the compressor, and reduce noise level emitted to the power line.
 - (2) Surge absorber, varistor 1, 2, 5
Absorb external surges, such as induced lightning.
 - (3) IC1
IC for control of switching power.
 - (4) IC4
DC/DC converter IC for generating 5V from 12V.
 - (5) IC9
DC/DC converter IC for generating B-5V from B-15V.
- Inverter Microcomputer Power Control
The power to the inverter microcomputer is turned ON/OFF by commands from the main microcomputer. Q502, PQ102, Q101, and Q102 are related.
- Specifications and Checkpoints for Main Power Supply Circuits

Output Name	Voltage Specification	Primary Load	± Measurement Location	Examples of Possible Failure Modes for Output Failures (for Reference)
B-15V output	15.5 ±1.5 V	Indoor/outdoor communication	Tester ⊕ terminal: B-15V indicator (L107) Tester ⊖ terminal: B-0V indicator (J5)	LD401 ~ LD403 (green) do not light or blink.
B-12V output	12 ^{+4,-2} V	Expansion valve	Tester ⊕ terminal: B-12V indicator (R120) Tester ⊖ terminal: B-0V indicator (J5)	LD351 (red) blinks 5 or 6 times (related to refrigerant cycle error) and stops.
B-5V output	5 ±0.4 V	Main microcomputer thermistor	Tester ⊕ terminal: B-5V indicator (J4) Tester ⊖ terminal: B-0V indicator (J5)	LD353 (green) does not blink. LD351 (red) does not blink. Outdoor unit does not operate.
5V output	5 ±0.4 V	Inverter microcomputer	Tester ⊕ terminal: 5V indicator (R814) Tester ⊖ terminal: 0V indicator (C891)	LD351 blinks 8 times.
12V output	12 ±1 V	IC2, 3, 4, 5, 6 relay circuits	Tester ⊕ terminal: 12V indicator (WH65-2) Tester ⊖ terminal: 0V indicator (C891)	LD351 blinks 2, 4, 8 or 14 times and then stops..
16V output	15.5 ±1.5 V	Compressor IPM DC fan drive circuit Converter circuit	Tester ⊕ terminal: 16V indicator (J9) Tester ⊖ terminal: 0V indicator (C891)	LD351 blinks 3, 4 or 12 times and then stops.

- Check each voltage. If the above specifications are satisfied, the main power supply circuit can be considered normal.
- Due to high voltage, be particularly careful to avoid electric shock. Further, take care to avoid short-circuit accidents caused by incorrect connection of measuring instruments. Otherwise, the board could be damaged.
- Even after the power is turned off, an electric charge remains in the smoothing capacitor, and a voltage of 260V to 360V is applied between the terminals of the smoothing capacitor.

(3) Smoothing Capacitor (C019~022, 500 μ F, 450V)

Boosts and smoothes (averages) voltage rectified by the diode.

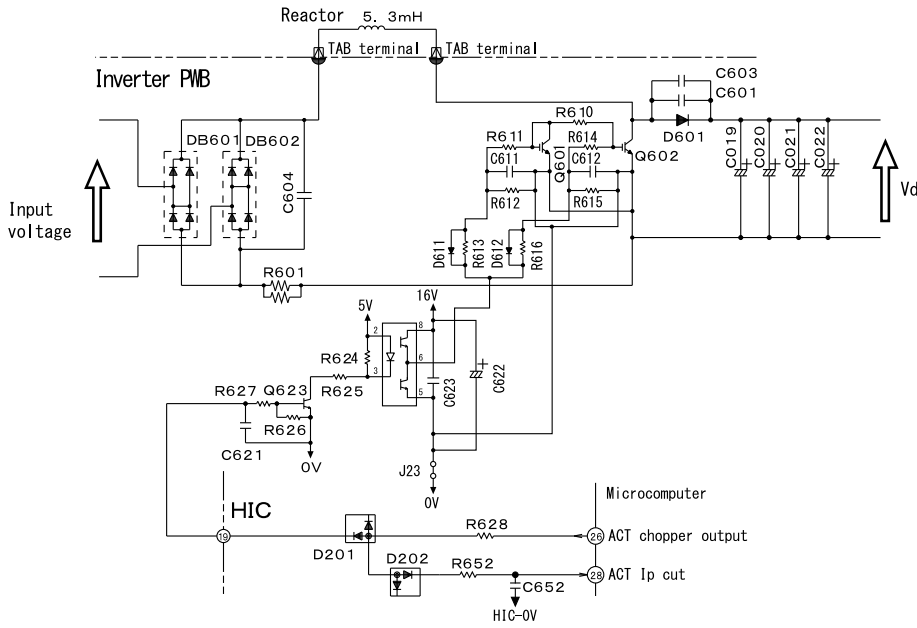

Fig. 2-2

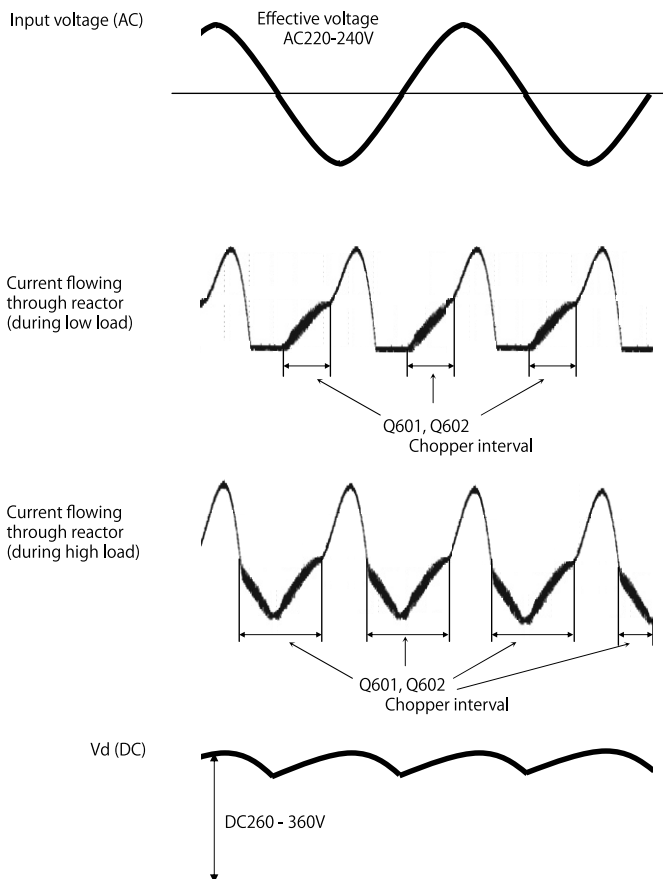

Fig. 2-3

(4) IGBT for improving power factor (Q601, Q602)

When load on the compressor increases, the power factor is improved by applying current to the chopper interval between Q601 and Q602 shown in Fig. 2-3.

3. Reversing Valve Control Circuit

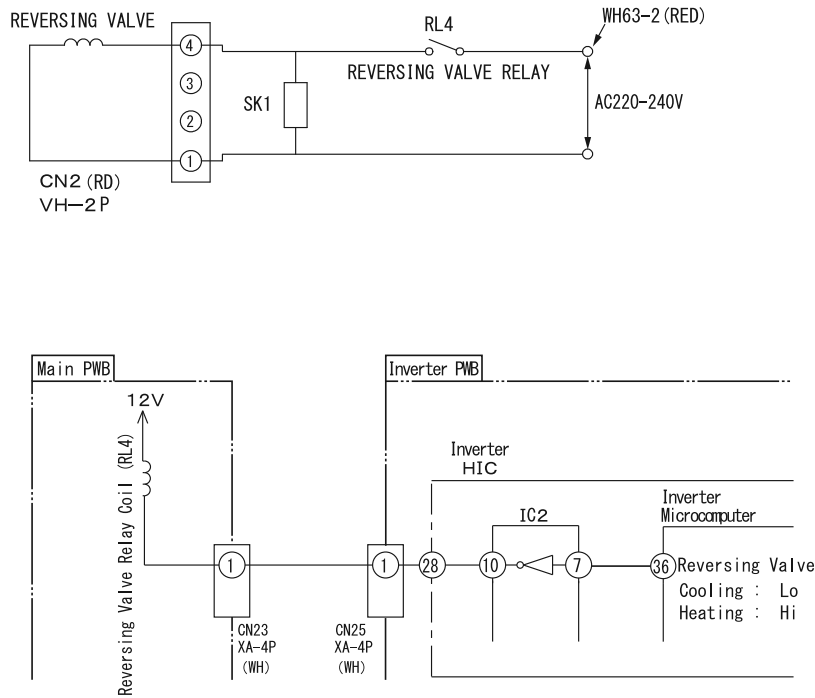

Figure 3-1

- The reversing valve is controlled by operation commands from the indoor microcomputer. Current is applied to the reversing valve coil in the direction designated for each operation mode to slide the valve.
- Before checking the power to the reversing valve, remove the CN2 connector, measure the resistance at both ends of the connector to see if it is $1970 \pm 138 \Omega$. Perform the following power checks only if the result of this check is normal. If this check produces an abnormal result, either a lead wire is broken or there is a failure in the reversing valve.
- Voltage at each point is approximately as shown below table when measure by tester.
(When voltage between pin 1 to pin 4 of CN2 is measured).

Operation Condition		Voltage between pin 1 to pin 4 of CN 2
Cooling	General operation of cooling	About 0V
Heating	In normal heating operation	About AC 220-240V
	MAX. rotation speed instructed by indoor microcomputer after defrost is completed.	About AC 220-240V
	Defrosting	About 0V

Inspection when Timer Lamp on Indoor Unit Flashes Once

Note: Be sure to turn the power off before performing the following inspection.

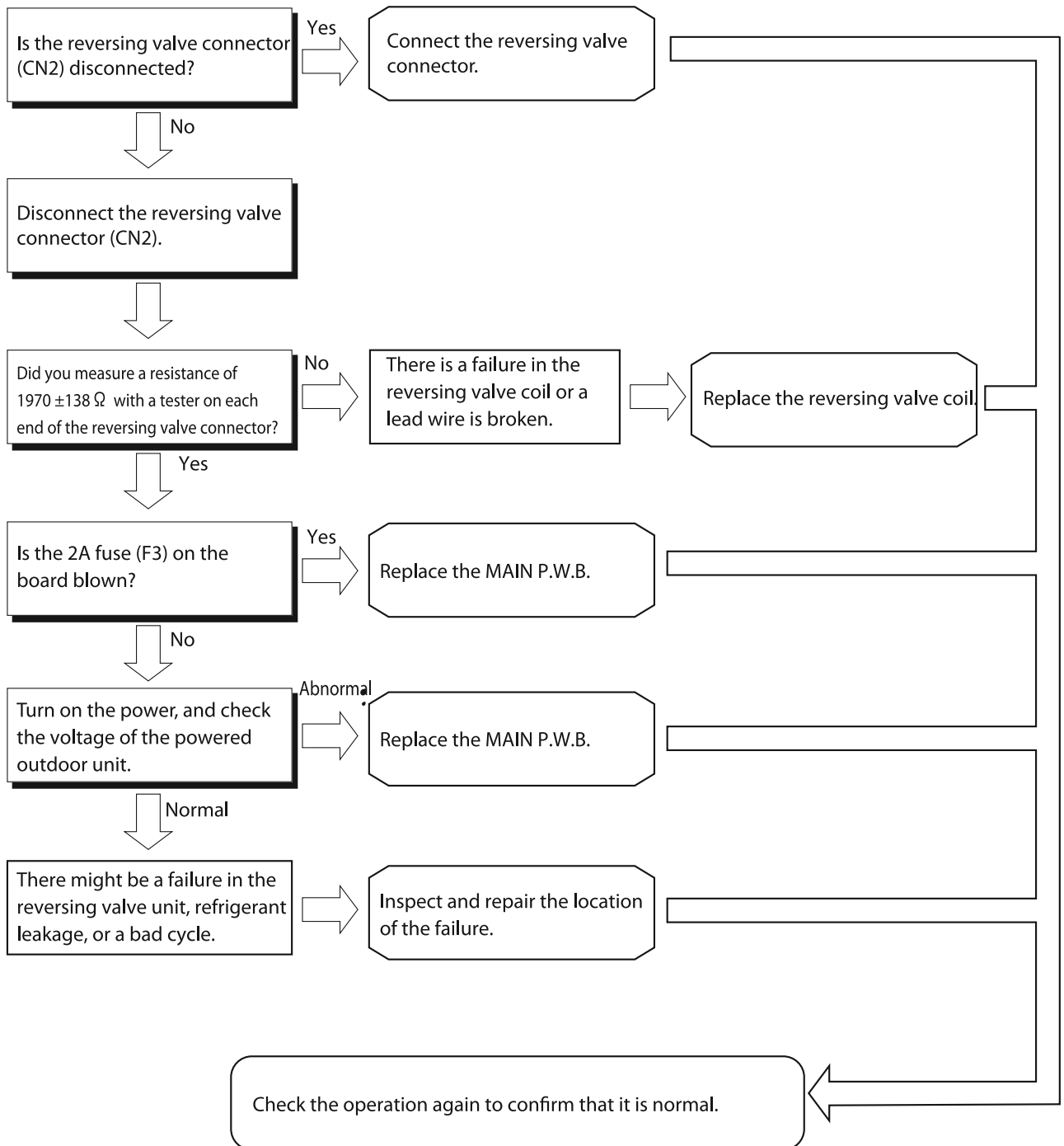

4. Temperature Detection Circuit

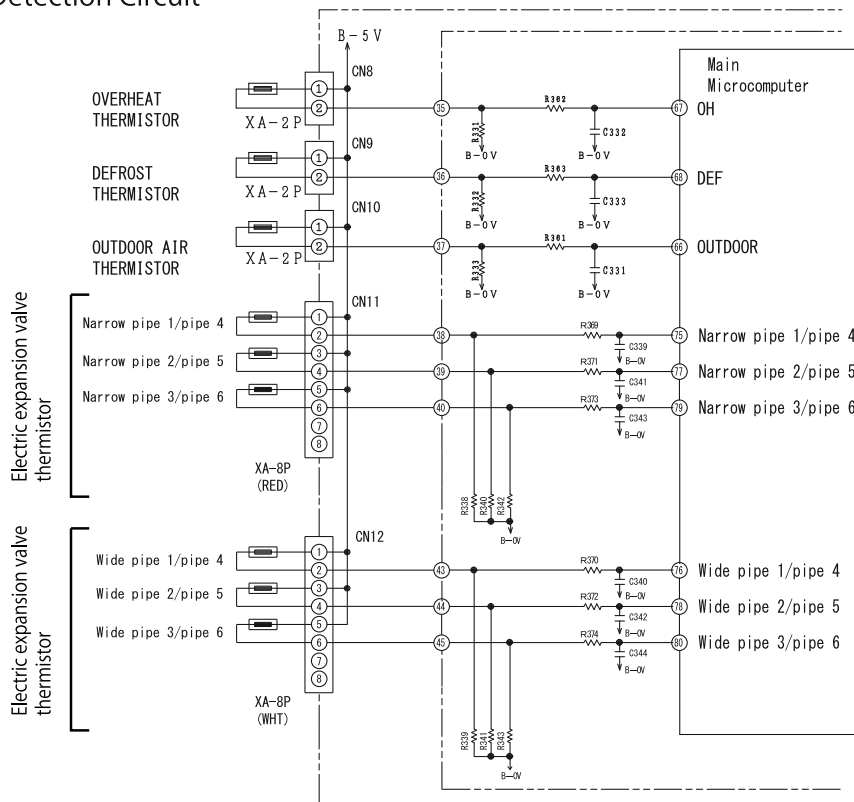

Fig. 4-1

- The OH thermistor circuit detects compressor head surface temperature, the DEF thermistor circuit detects defrost operating temperature, and the outside air temperature thermistor circuit detects the outside air temperature. In addition, the electric expansion valve thermistor (narrow pipe 1) detects the temperature of narrow pipe going to indoor unit 1 and (wide pipe 1) detects the temperature of the wide pipe going to indoor unit 1. (Narrow pipe 2) and (wide pipe 2) are for indoor unit 2. (Narrow pipe 3) and (wide pipe 3) are for indoor unit 3. (Narrow pipe 4) and (wide pipe 4) are for indoor unit 4. (Narrow pipe 5) and (wide pipe 5) are for indoor unit 5. (Narrow pipe 6) and (wide pipe 6) are for indoor unit 6.
- Thermistors are negative resistance elements. The resistance value grows smaller as the temperature rises, and grows larger as the temperature falls.
- If the compressor overheats, the resistance value of the OH thermistor grows smaller. B-5V is divided between the OH thermistor and R331, and therefore the voltage of pin ⑦⑦ on the main microcomputer rises.
- The voltage of pin ⑦⑦ on the main microcomputer is compared with the value set and stored internally. If the set value is exceeded it is determined that the compressor has overheated, and operation is stopped.
- If frost accumulates on the outdoor heat exchanger, the temperature of the heat exchanger will fall rapidly. Therefore, the resistance value for DEF thermistor grows large and the voltage of pin ⑦⑧ on the microcomputer falls. If this voltage drops below the value set and stored internally, defrosting of the main microcomputer will start.
- Outdoor temperature is read by the outdoor temperature thermistor (voltage of pin ⑦⑥ on the microcomputer). Commands from the indoor microcomputer, values read from the outdoor temperature thermistor, and values read from the OH thermistor are taken into account to control the speed of the compressor and the speed of the outdoor fan. Typical values that indicate the relationship between outdoor temperature and voltage are shown below.

Table 4-1

Outdoor temperature (°C)	-10	0	10	20	30	40
Voltage (V) at both ends of R333	1.19	1.69	2.23	2.75	3.22	3.62

- The temperatures at narrow pipe 1 - 6 and wide pipe 1 - 6 are read by thermistors, and the amount that electric expansion valves 1 - 6 are opened is changed to control the distribution of refrigerant.

Reference:

When a thermistor is open and disconnected, pins ⑦⑥ - ⑦⑧ and ⑦⑤ - ⑦⑩ on the main microcomputer are approximately 0V. When there is a short-circuit in a thermistor, these pins are approximately 5V, LD351 will lit and LD352 blinks during standby mode or running. Except for overheat thermistor, if there is a short-circuit in a overheat thermistor the LED indication during standby mode and running will be different as below Table 4-2.

The number of blinks by LD352 indicates the area/portion in unit that thermistor detect have problem.

Table 4-2

Unit condition	LD351 indication	LD352 indication
Standby Mode	Lit	1 time blinking
Running	6 times blinking	Off

5. Electric Expansion Valve Circuit

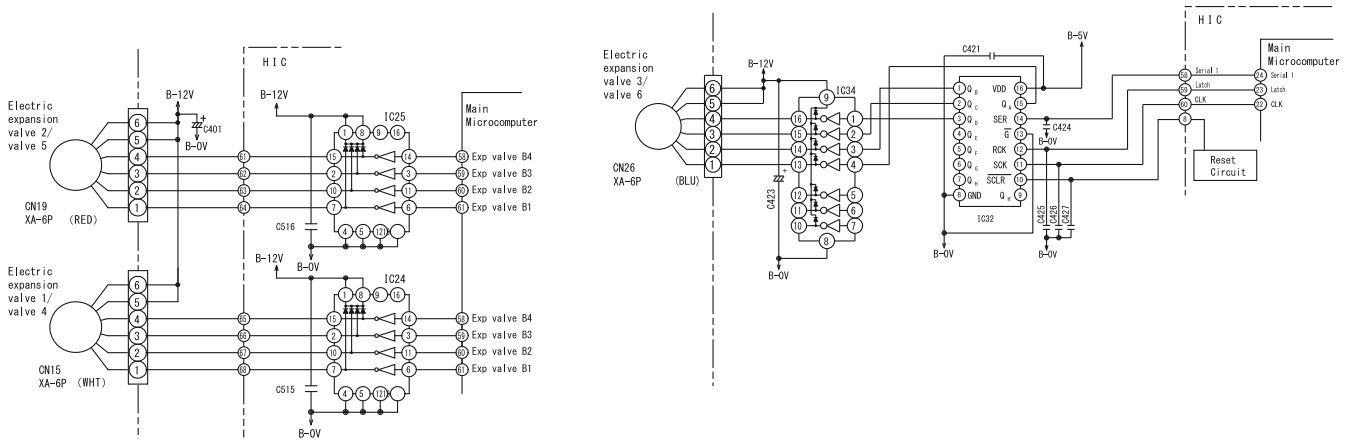

Fig. 5-1

- There are six electric expansion valves for indoor units 1-6.
- The electric expansion valves are powered by B-12V for expansion valves. 1- or 2-phase current is applied to 4-phase wound wires, switching the poles of the wound wires to control valve openings.
- The relationship between the switching direction of the current phase and the open/close direction of the valves is shown in the following table. When current is applied, approximately 0.9V passes through pins ①-④ of CN15, CN19, and CN26; when no current is applied, it is approximately 12V. When the power is reset, the expansion valve is initialized for approximately 35 seconds. During initialization, use a tester to measure pins ①-④ on CN15, CN19, and CN26. If there is a pin that does not change at approximately 0.9V or 12V, there is an abnormality in that expansion valve or the main microcomputer.
- The logic waveform for when an expansion valve operates is shown in Fig. 5-2.

Table 5-1

CN15, CN19, CN26 Pin No.	Lead wire	Power conditions							
		1	2	3	4	5	6	7	8
④	White	ON	ON	OFF	OFF	OFF	OFF	OFF	ON
③	Yellow	OFF	ON	ON	ON	OFF	OFF	OFF	OFF
②	Orange	OFF	OFF	OFF	ON	ON	ON	OFF	OFF
①	Blue	OFF	OFF	OFF	OFF	OFF	ON	ON	ON

Operation mode
 1→2→3→4→5→6→7→8 VALVE CLOSE
 8→7→6→5→4→3→2→1 VALVE OPEN

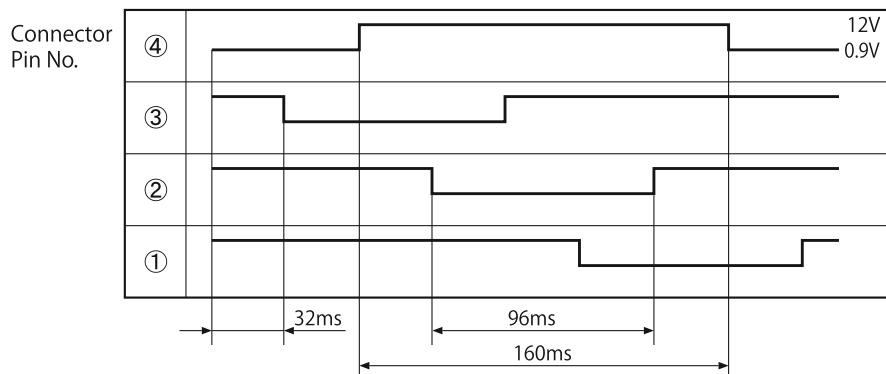

Fig. 5-2

When controlling an expansion valve, the temperature of the compressor head is detected and then the opening is adjusted to stabilize the valve to the target temperature. This control cycle is performed once every 20 seconds, and a few pulses are output.

- One (IC32) 8-bit type shift register ICs that convert serial signal input to parallel and output the parallel signals are used on the circuits of electric expansion valves 3/valve6.
- An example of circuit operation when an expansion valve is powered is shown in the time chart in Fig. 5-3.
 - ① A clock signal (16 cycles at 750μs/cycle) is output from pin ⑫ on the microcomputer. (One cycle for the clock signal is 500μs off, 250μs on.)
 - ② A serial signal #1 of the power pattern is synced with the clock signal and output from pin ⑭ of the microcomputer. #1 The serial signal is the pattern of the current applied to phase 1 or phase 2 of a 4-phase wound wire on an expansion valve, that has then been converted to serial format. A serial signal is output so that the center of the ON serial signal (Hi-level 500μs) aligns with the rising edge of the clock signal.

The content of the shift register in IC is updated by operations① and ② described above.

Next, 250μs after the ON signal is output for the 16th cycle of the clock signal,

- ③ the latch signal from pin ⑬ on the microcomputer is turned OFF (Lo-level 500μs) and then ON again (Hi-level).
- ④ After the time required to apply current has elapsed, if powering of the expansion valve is required the cycle returns to ① and repeats the operation.

With the operation described above, the opening of expansion valves is controlled while applying current to phase 1 or phase 2 of a 4-phase wound wire on an expansion valve, according to the content of the shift register updated when the current is applied. When the opening of the expansion valve reaches the target amount, the stop pattern described in ② above is applied and then operations ① - ④ are performed to complete the control of the expansion valve.

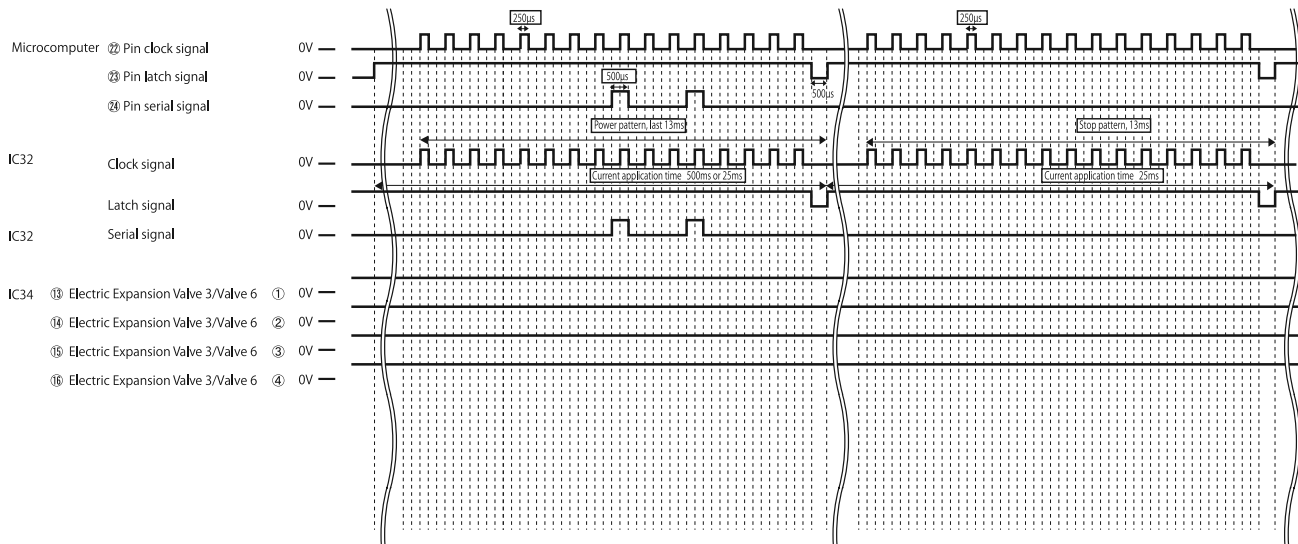

Fig. 5-3 Time Chart

6. Outdoor Fan Motor Control Circuit

- This outdoor unit is equipped with a built-in outdoor fan motor control circuit.

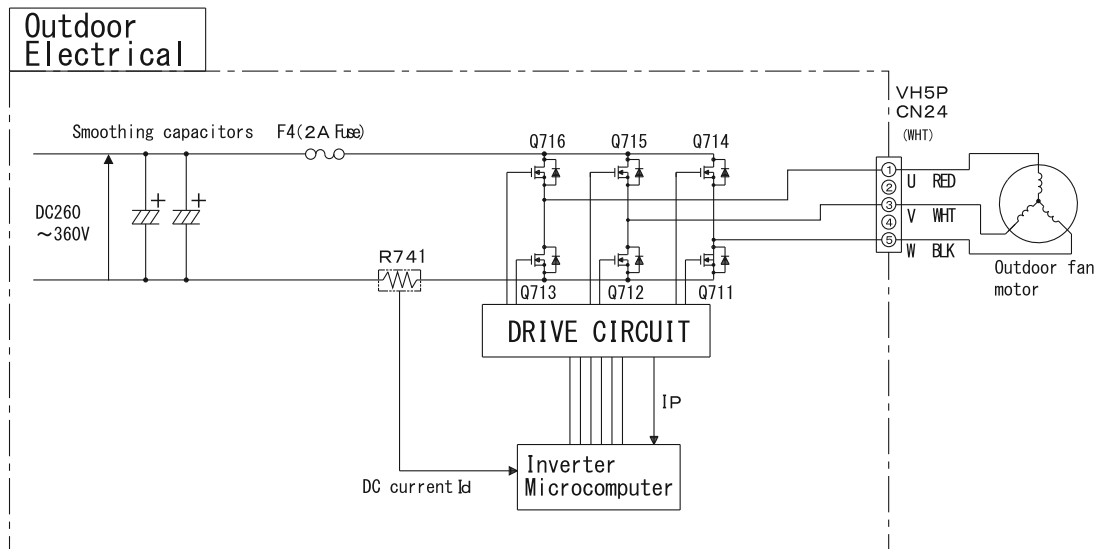

Fig. 6-1

Based on operation commands from the indoor microcomputer, the speed of the outdoor fan motor on this unit is determined by the main microcomputer and controlled by the inverter microcomputer.

Actual speed is estimated based on DC waveforms from R741 to control the speed so that it matches the operational commands.

Overcurrent and other failures in the outdoor fan motor are detected by the magnitude of the direct current.

(1) Control of outdoor fan motor at startup

If the propeller fan is already rotating at the start of operation, due to disturbances such as strong wind, operational behavior will vary according to the direction and speed of such rotation as described below. Favorable wind is defined as wind that blows outward from the mouth ring.

- Strong headwind : Control is not performed, to protect the equipment, and the propeller is blown in the opposite direction by the wind. The unit starts automatically once the wind has weakened.
- Headwind : After the speed reduces gradually and finally stops, the speed is controlled in the normal direction.
- Favorable wind : The speed of the fan is controlled normally.
- Strong favorable wind : Control is not performed, to protect the equipment, and the propeller is blown in the normal direction by the wind. The unit starts automatically once the wind has weakened.

(2) Control of outdoor fan motor during operation

The speed of the propeller fan might drop during operation of the outdoor fan motor due to disturbances such as strong wind.

If such conditions continue for a long period of time, the propeller fan will stop. (Self-diagnosis lamp LD351: Blinks 11 times)

When the fan is restarted, the operation described in (1) above is used.

(3) Confirmation method when self-diagnosis lamp LD351 blinks 12 times

If LD351 on the Main P.W.B. blinks 12 times (fan lock detected) and operation stops, use the following procedure to check the unit.

1. Mechanical locking caused by the insertion of foreign objects such as sticks into the propeller fan or freezing due to the accumulation of snow will cause fan lock to be detected and causing the unit stop its operation.
Remove any foreign objects.
2. Check whether CN24 is securely inserted. A poor connection will cause a fan lock detection and causing the unit stop its operation. If CN24 is loose, insert it securely.
3. Strong wind around the outdoor unit might cause a fan lock detection.
Check if the unit restarts. (Several minutes might be required for the unit to restart.)
If the unit continues to operate after restarting, there is no failure in the outdoor fan motor or electrical components.
4. Perform a check of the outdoor fan motor. The procedure is shown below.

Procedure for Checking the Outdoor Fan Motor

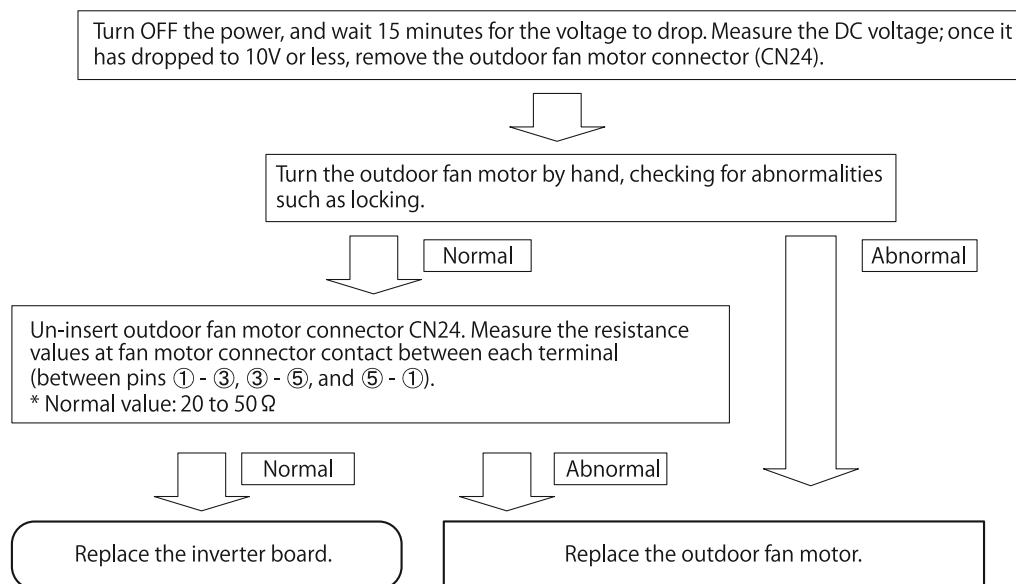

5. Insert the outdoor fan motor connector (CN24).

* Also use the above procedure if F4 (2A fuse) is blown.

Caution

* The power supply for the outdoor fan motor is also used as the power supply for the compressor, and therefore has a high voltage (DC260 to 360V). Use sufficient caution to avoid electric shock when checking operations and performing repairs.

8. Indoor/outdoor communication circuit

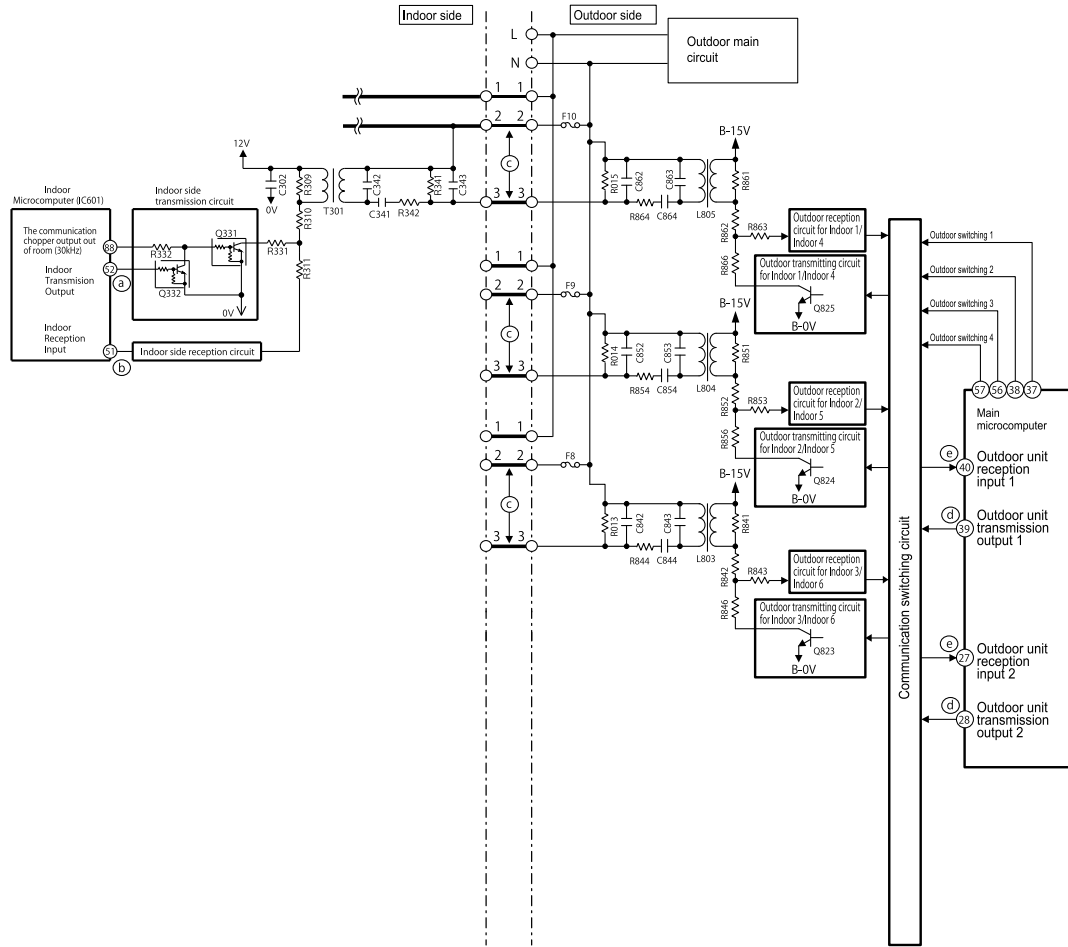

Fig. 5-1

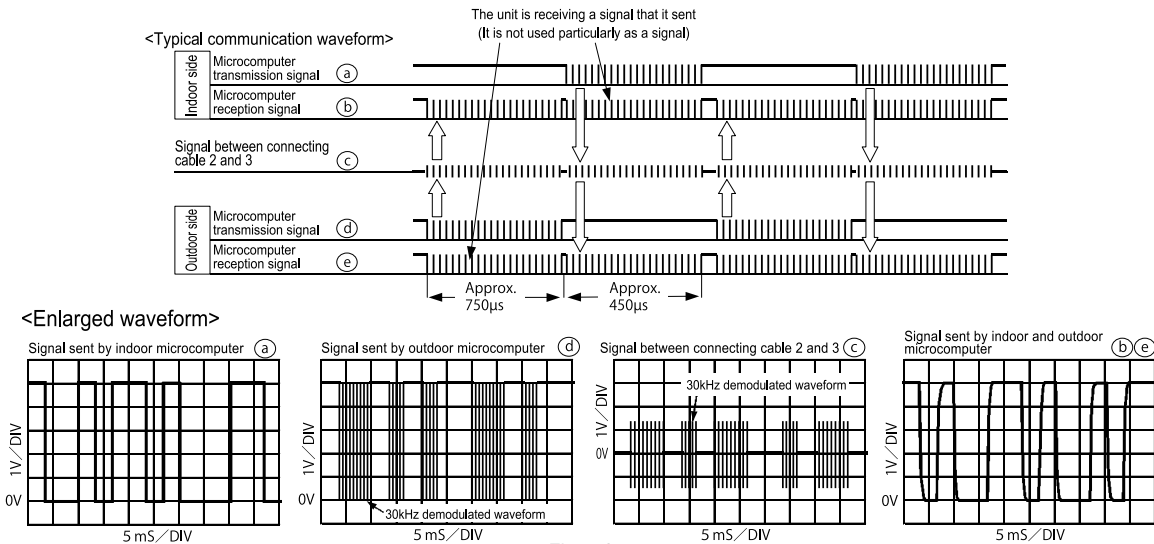

Fig. 5-2

- * Indoor and outdoor communications are conducted by using lines 2 and 3 of connecting cable. Line 2 of connecting cable is share with a transmission channel that powers the indoor unit.
- * Data communicated between the indoor and outdoor units are outputted from the microcomputer as serial signals and are transmitted as demodulated by a 31kHz carrier wave (for indoor) and a 30kHz carrier wave (for outdoor).

Check

If the communication fails between the indoor and outdoor units for some reason, the product will give a self-diagnosis display either by "the timer lamp blinking 3 times (indoor failure)" or "the the timer lamp blinking 12 times (outdoor failure)" depending on the cause.

PRECAUTION FOR CHECKING



DANGER

1. Remember that the 0V line is biased to 162V in reference to the ground level.
2. Also note that it takes about 10 minutes until the voltage fall after the power switch is turned off.

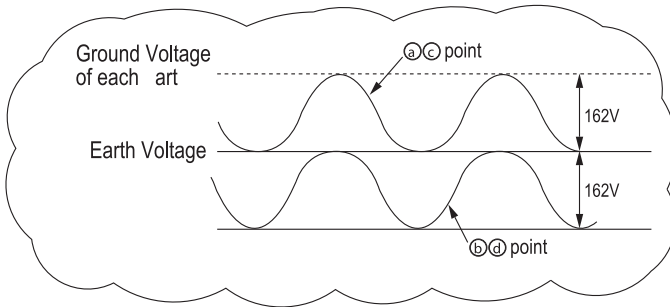
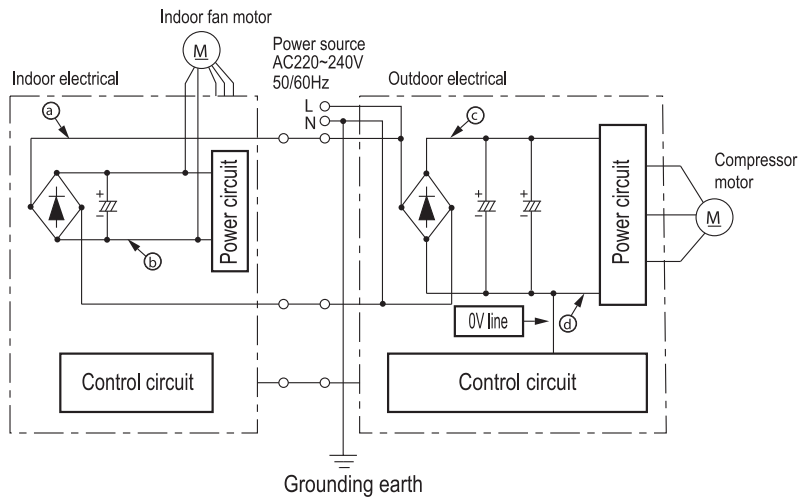

DANGER

When using an oscilloscope, never ground it. Don't forget that high voltages as noted above may apply to the oscilloscope.

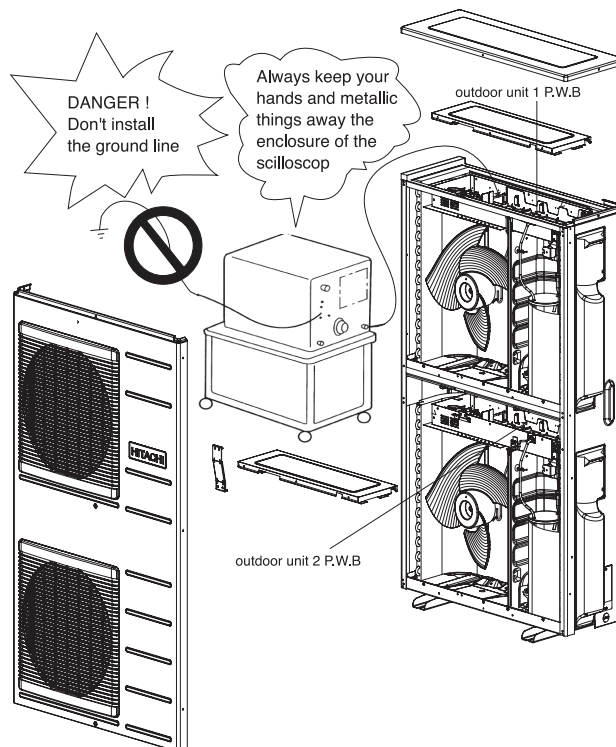

SELF CHECK

When it is difficult to judge whether the compressor or the electrical part is faulty resulting self diagnosis lamp LD351 blink 2,3,4 or 5 times, please confirm first the compressor terminal insulation by using mega ohm checker. If the insulation is normal, proceed to below self-check method.

■ Self-check diagnosis method

1. Switch OFF main power supply. (Wait until DC voltage fully discharged :15 minutes or more)
2. Un-insert jumper wire connector at CN30.
3. Switch ON main power supply. (LD352 will blink 1 time)
4. Press and hold TEST SWITCH for more than 1 second.
 - IPM and the compressor motor will activated and each IGBT inside IPM will be checked internally by inverter microcomputer. Microcomputer will detect short-circuit and open-circuit of the IPM to determine IPM condition either in good condition or already broken.
5. Self-check diagnosis result will appear.
 - The content of diagnosis result shall refer to below table.

■ Self-check diagnosis result

[SELF-CHECK] DIAGNOSIS RESULT		
LD301	DIAGNOSIS CONTENT	REPAIR METHOD
1 TIME BLINK	ELECTRICAL OK.	CHANGE COMPRESSOR.
2 TIMES BLINK	PEAK CURRENT CUT OFF SIGNAL DETECTED.	CHANGE INVERTER P.W.B.
7 TIMES BLINK	COMPRESSOR CURRENT ABNORMAL.	COMPRESSOR CONNECTOR LOOSE->CHECK CONNECTOR. AFTER CHECK COMPRESSOR CHANGE INVERTER P.W.B.
10 TIMES BLINK	DC VOLTAGE ABNORMAL.	AC VOLTAGE ABNORMAL (BEYOND RATED $\pm 10\%$) ▶ CONNECT WITH CORRECT AC VOLTAGE. AC VOLTAGE NORMAL (WITHIN RATED $\pm 10\%$) ▶ CONNECTOR (CN23,CN25) BAD INSERTION->CHECK CONNECTOR OTHER => CHANGE BOTH MAIN & INVERTER P.W.B.
13 TIMES BLINK	EEPROM READING ERROR.	CHANGE INVERTER P.W.B.

In case abnormality found at the checking result, please confirm the connecting cord having problem or not before replace the defect part according to the table of self-check diagnosis result.

In case no abnormality found at electrical part, insert back the jumper wire connector at CN30 as original condition before it can be use.

※If forgot to insert back as per original condition, the system will operate as below table condition after power restored.

Time after power restored	Unit condition
Below than 3 minutes	Indoor timer lamp will 12 times blinking (show error - outdoor communication circuit failure).
3 ~ 6 minutes	Can run as normal.
After 6 minutes	Unit enter hibernation mode. Can run as normal.

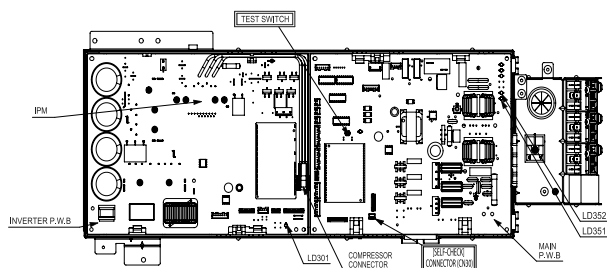

Outdoor Unit 1
(Connected to Indoor 1, Indoor 2 & Indoor 3)

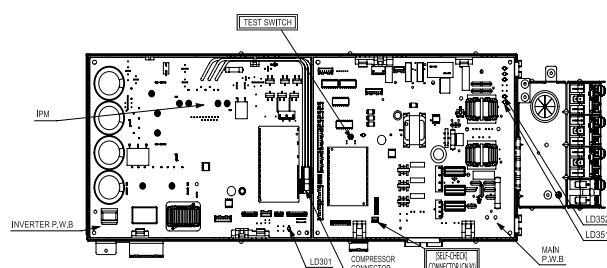

Outdoor Unit 2
(Connected to Indoor 4, Indoor 5 & Indoor 6)

Collect refrigerant using test switch operation

1. Turn OFF the breaker and wait for 1 minute or more before turn ON back the breaker.
2. Detach the electrical cover of outdoor unit and ensure LD353 is blinking once.
3. Wait 20 seconds or more before pressing the test switch for 1 second or more to start the forced cooling operation.
4. Pressing the test switch again for 1 second or more will stop the operation.

Outdoor Unit 1 (Connected to Indoor 1, Indoor 2 & Indoor 3)

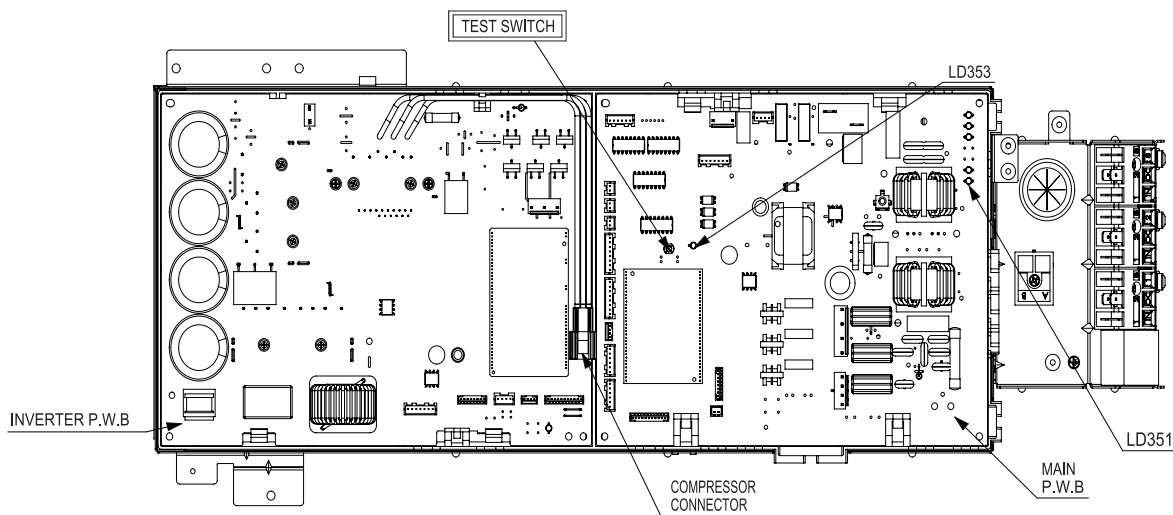

Outdoor Unit 2 (Connected to Indoor 4, Indoor 5 & Indoor 6)

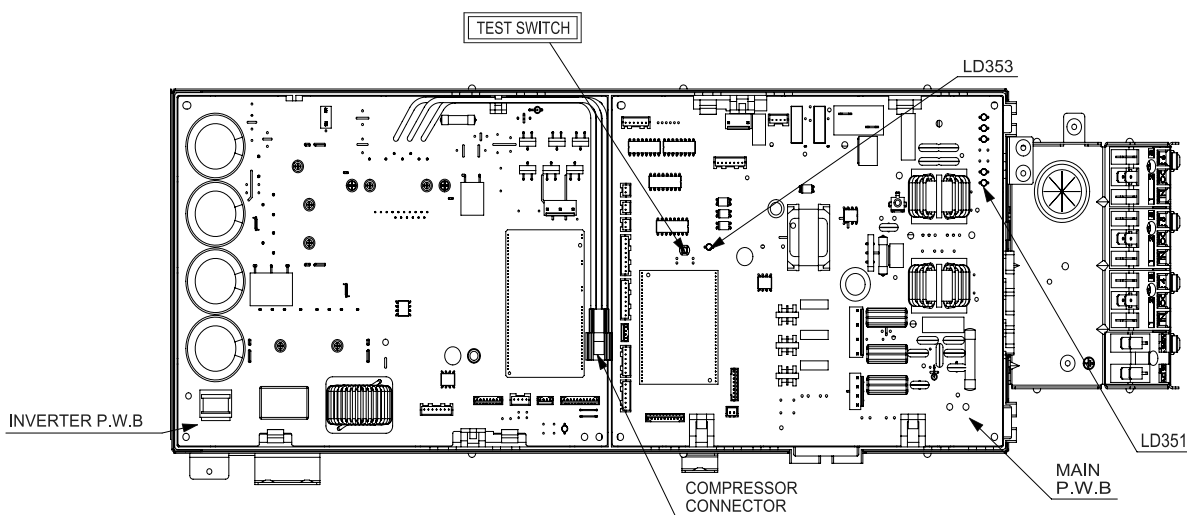

■ Cautions

1. Do not any circumstances operate the outdoor unit for more than 5 minutes.
2. Doing work with the compressor connector removed will cause the LD351 to blink 4 times. It will not start the operation.
3. For another test run, turn OFF the breaker and turn it back ON to reset the power supply. (The test switch is accepted only once after power ON. After operation by remote controller, it is not accepted.)
4. When the operation with the test switch is done, turn OFF the breaker.

How to operate the outdoor unit independently

1. Connect the large dia. pipe side and small dia. pipe side service valves using a pipe.

Connect the small diameter service valve and the large diameter service valve using the reducing union and copper pipe as shown on the right.

Charge refrigerant of 300g after vacuuming (※1)

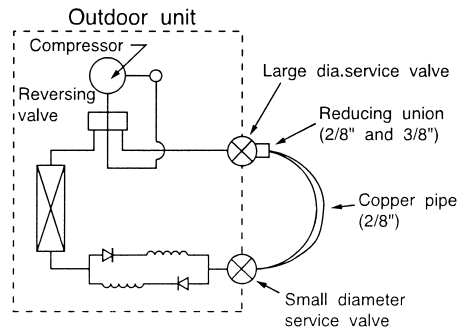

Parts to be prepared

- (1) Reducing union
2/8" (6.35mm)
3/8" (9.52mm)
- (2) Copper pipe (2/8" and 3/8")

Do not operate more than 5 minutes

The operation method is the same as "Collect refrigerant using test switch".
※1 The charging amount of 300g is equivalent to the load in normal operation.

Lighting mode of the self-diagnosis lamp

1 Mounting location of the self-diagnosis lamp

Outdoor Unit 1 (Connected to Indoor 1, Indoor 2 & Indoor 3)

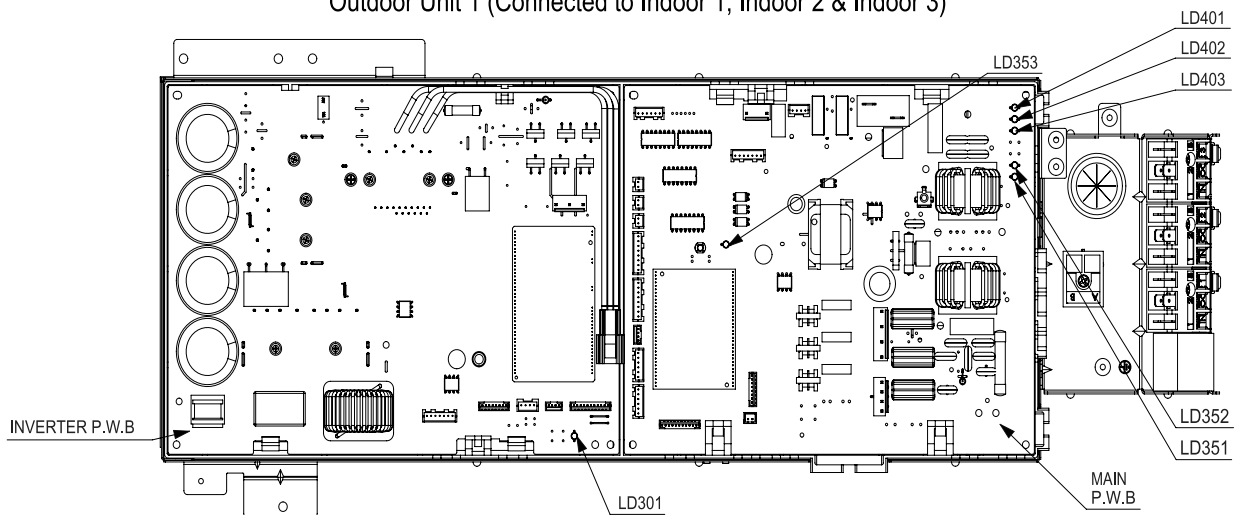

Outdoor Unit 2 (Connected to Indoor 4, Indoor 5 & Indoor 6)

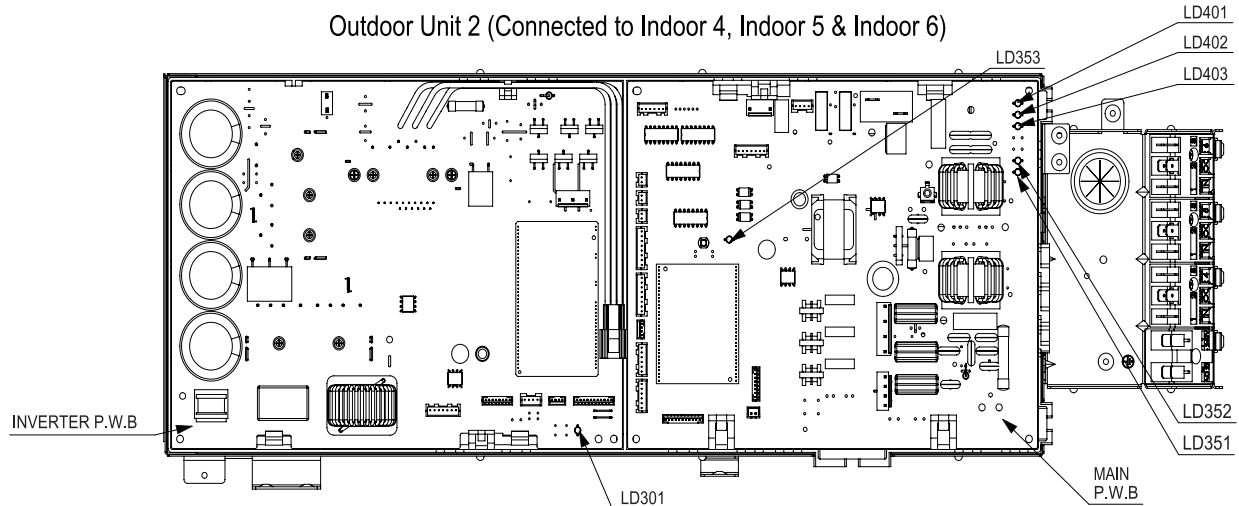

Refrigerant cycle check (gas leak or compressor failure)

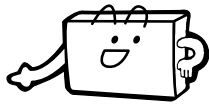

Operate the unit after re-connect the connector for compressor.

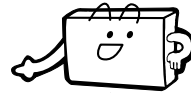
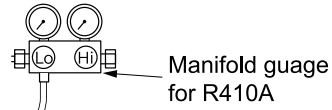

Refer to cycle inspection mode.



Is the self-diagnosis lamp shown as per this table?

LD351	2 times blink	3 times blink	4 times blink	5 times blink	ON
LD352	OFF	OFF	OFF	OFF	1 time blink
Time to blink	2~3sec			About 10sec	Within 30min
Suspect failure item	Compressor				Gas leak

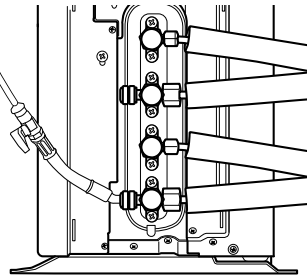

Outdoor electrical assembly

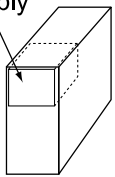

Normal

Abnormal (gas leak)



Outdoor electrical assembly
 ■ Check drive signal using PRD checker

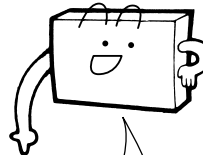

It is a gas leak.
 Please repair and re-charge the gas.



Normal
 (When the self-diagnosis lamp is the same to above figure lighting mode)

Re-charge gas







Compressor is abnormal.
 Please change it and re-charge gas.

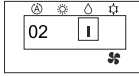

Change compressor

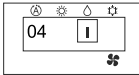
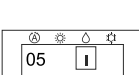
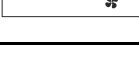
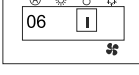
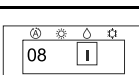
Perform final basic operation check

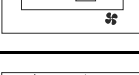
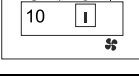
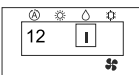
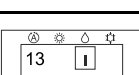
List of error code when using Self-Diagnosis Memory Function

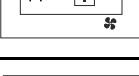
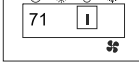
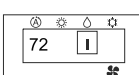
Please refer to the display screen of wireless or wired remote control.
(This error code only for error happen at outdoor side)

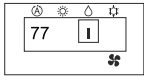
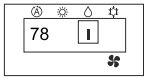
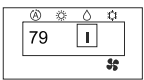
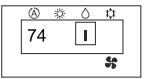
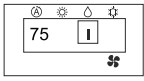
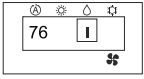
INDOOR OPERATION LAMP BLINKING	WIRELESS REMOTE CONTROL DISPLAY	WIRED REMOTE CONTROL DISPLAY	SELF-DIAGNOSE CONTENT	ERROR DESCRIPTION DETAIL	MAIN CHECK POINT
2 times	002 01		Peak current cut.	Over current is detected.	1. Compressor 2. Inverter P.W.B.
3 times	003 01		Compressor abnormal low speed rotation.	Position detection signal has no input during operation.	1. Compressor 2. Inverter P.W.B.
4 times	004 01		Compressor switching failure.	Fail to switch from initial low frequency sync to position detection sync.	1. Compressor 2. Inverter P.W.B.
5 times	005 01		Overload lower limit cut.	Overload condition still persisting even rotation speed is below the lower rpm limit.	1. Outdoor unit is expose to direct sunlight or its air flow blocked. 2. Fan motor 3. Fan motor circuit 4. The voltage is extremely low
6 times	006 01		OH thermistor temperature rise.	OH thermistor is operating.	1. Leak of refrigerant 2. Compressor 3. OH thermistor circuit 4. Fan motor 5. Fan motor circuit
8 times	008 01		Communication error between microcomputer.	Communication between inverter microcomputer and main microcomputer failed.	1. Connector insertion at CN21 & CN22 2. Main and Inverter P.W.B.
9 times	009 01		Indoor type mismatch.	Single model connected.	1. Main P.W.B. 2. Indoor unit
10 times	010 01		Abnormal power source.	Power supply voltage is incorrect.	1. Power supply voltage 2. Main or Inverter P.W.B. or both P.W.B.
12 times	012 00		Fan motor faulty.	Outdoor fan rpm is not rotate as intended rpm.	1. Fan motor 2. Fan motor circuit
13 times	013 01		EEPROM reading error.	Microcomputer cannot read the data in EEPROM.	1. Inverter P.W.B. If still NG after change Inverter P.W.B, change Main P.W.B.
14 times	014 01		Active converter defect.	Over voltage is detected or compressor load is abnormal.	1. Inverter P.W.B. 2. Compressor
7 times	071 01		Oveheat Thermistor	Thermistor's connector not connected or thermistor's wire worn out or shorted.	1. Thermistor 2. Connection of thermistor faulty 3. Thermistor circuit
7 times	072 01		Defrost Thermistor		
7 times	073 01		Outdoor Temperature Thermistor		
7 times	074 01		Narrow pipe thermistor abnormal (Indoor no.1)		
7 times	075 01		Wide pipe thermistor abnormal (Indoor no.1)		

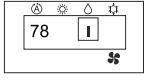
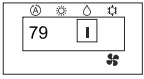
7 times	076 01		Narrow pipe thermistor abnormal (Indoor no.2)	Thermistor's connector not connected or thermistor's wire worn out or shorted.	1. Thermistor 2. Connection of thermistor faulty 3. Thermistor circuit
7 times	077 01		Wide pipe thermistor abnormal (Indoor no.2)		
7 times	078 01		Narrow pipe thermistor abnormal (Indoor no.3)		
7 times	079 01		Wide pipe thermistor abnormal (Indoor no.3)		
7 times	074 01		Narrow pipe thermistor abnormal (Indoor no.4)		
7 times	075 01		Wide pipe thermistor abnormal (Indoor no.4)		
7 times	076 01		Narrow pipe thermistor abnormal (Indoor no.5)		
7 times	077 01		Wide pipe thermistor abnormal (Indoor no.5)		
7 times	078 01		Narrow pipe thermistor abnormal (Indoor no.6)		
7 times	079 01		Wide pipe thermistor abnormal (Indoor no.6)		

Checking Electrical Parts of Outdoor Unit

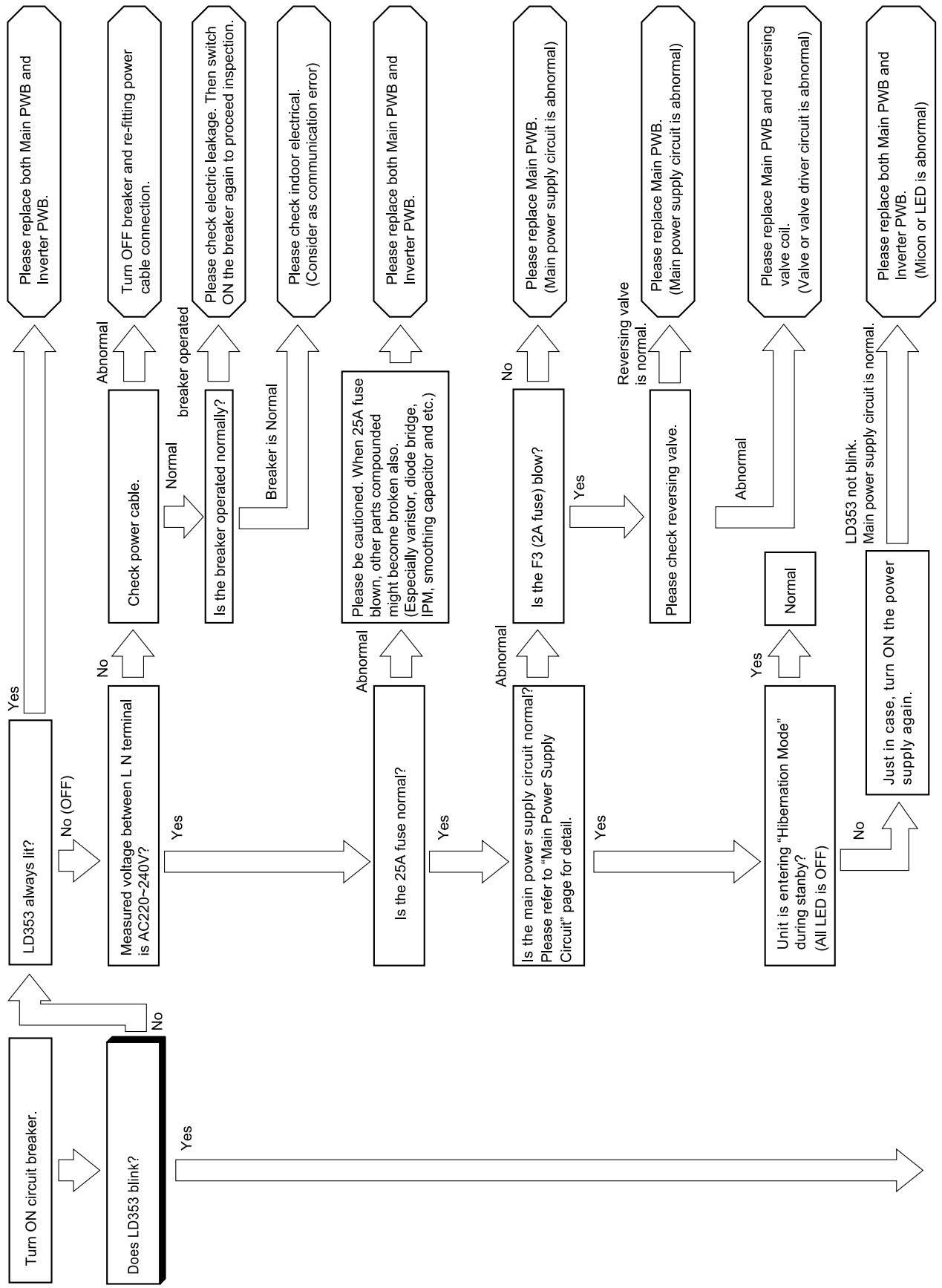

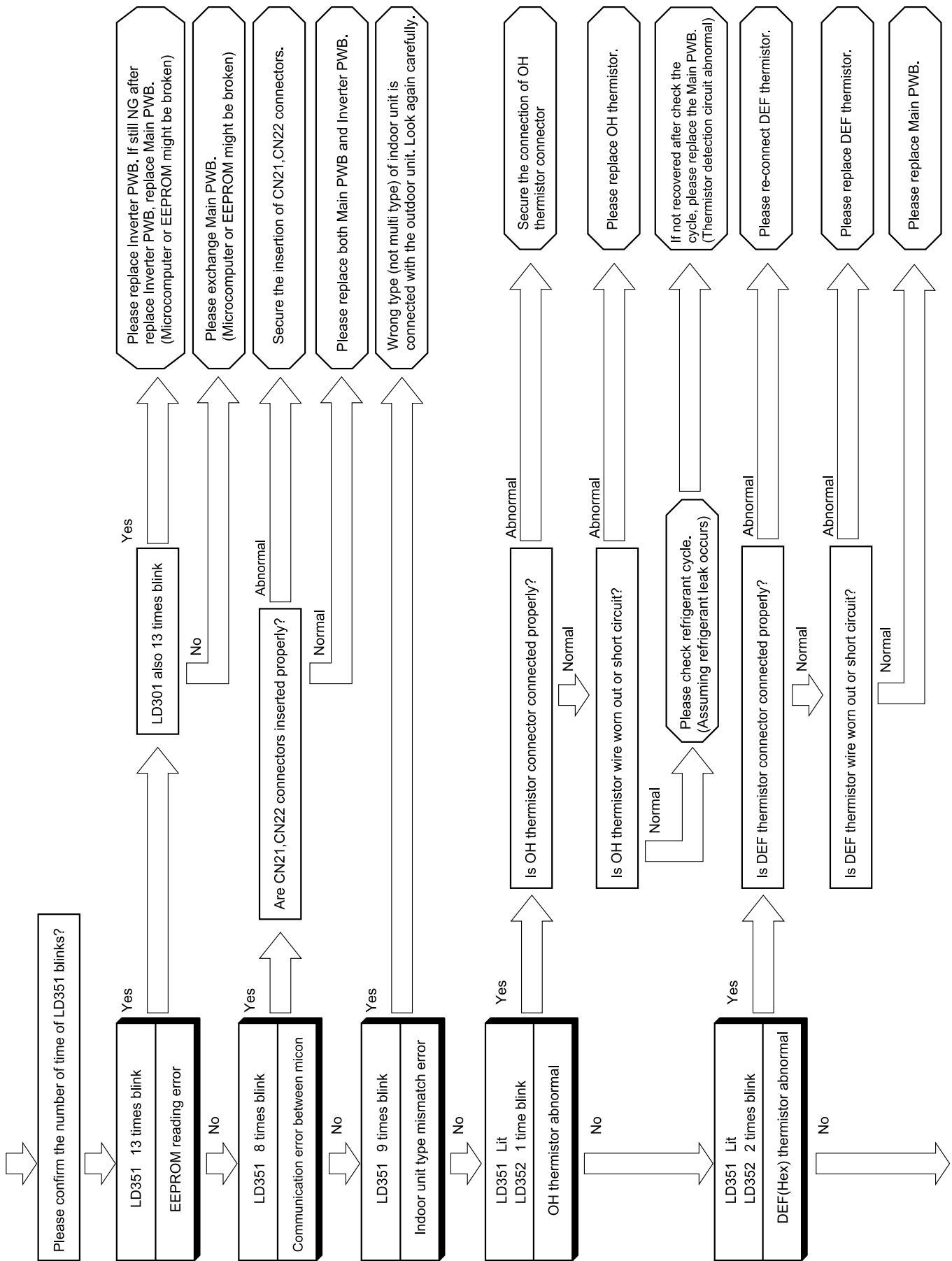

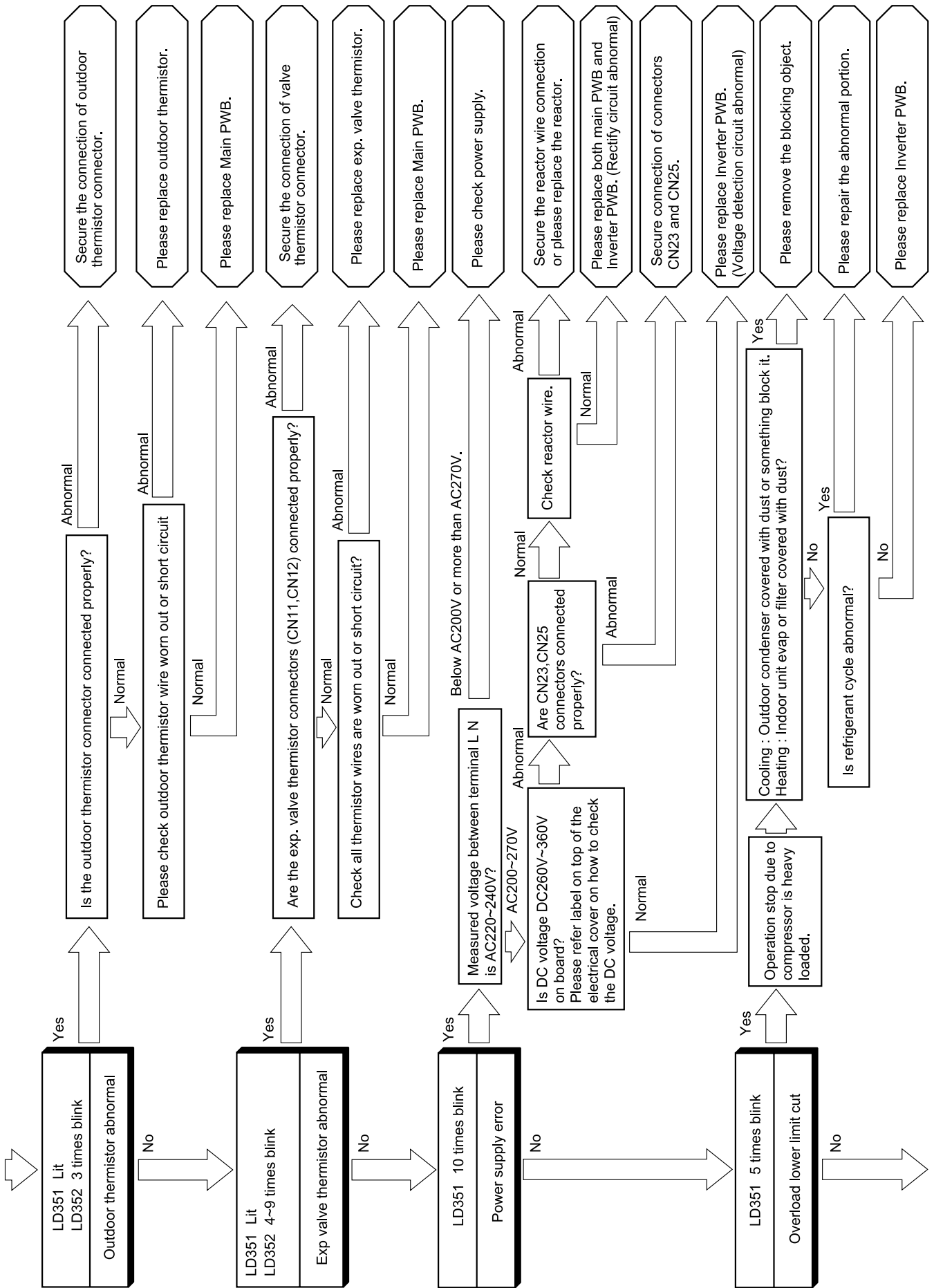

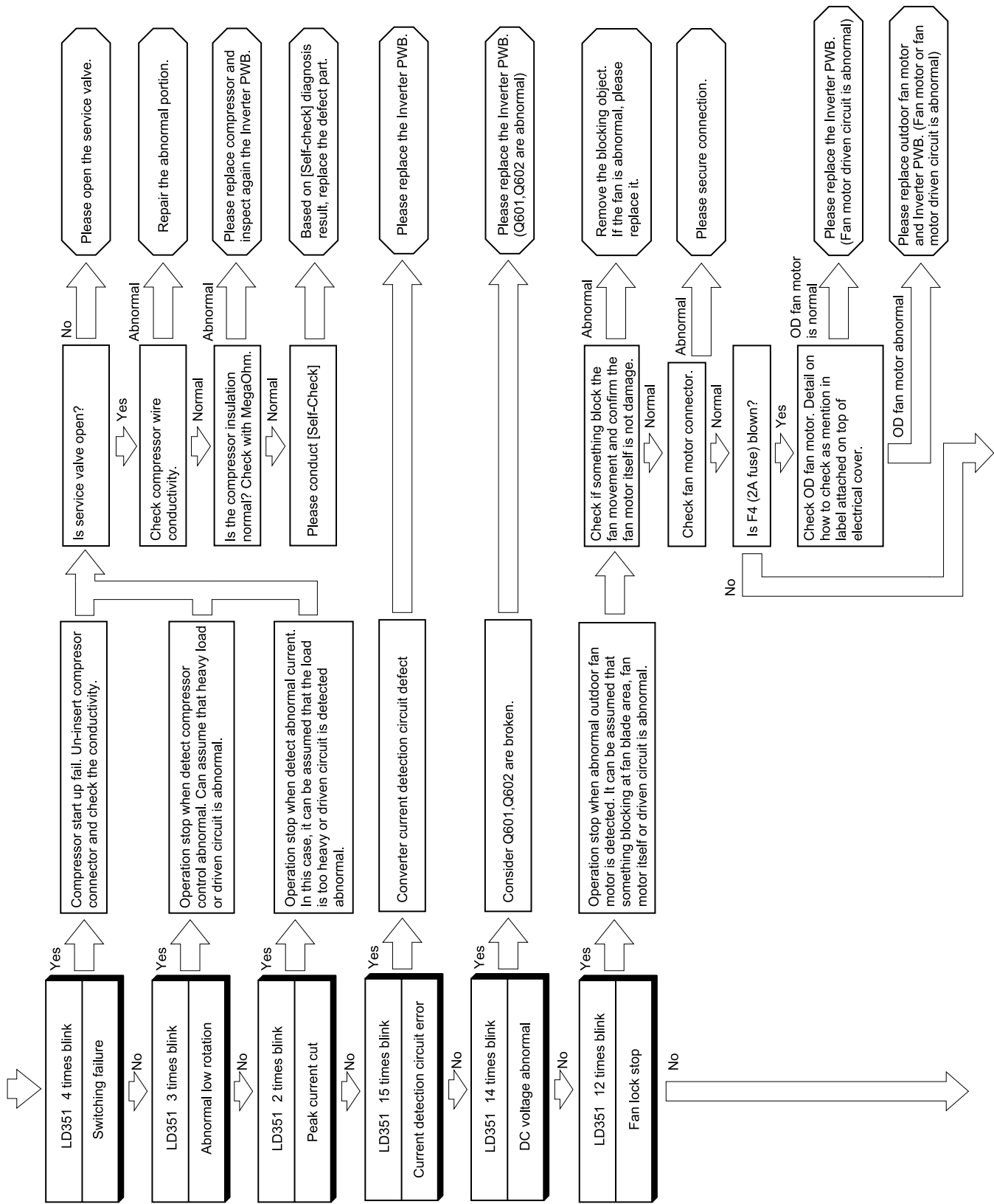

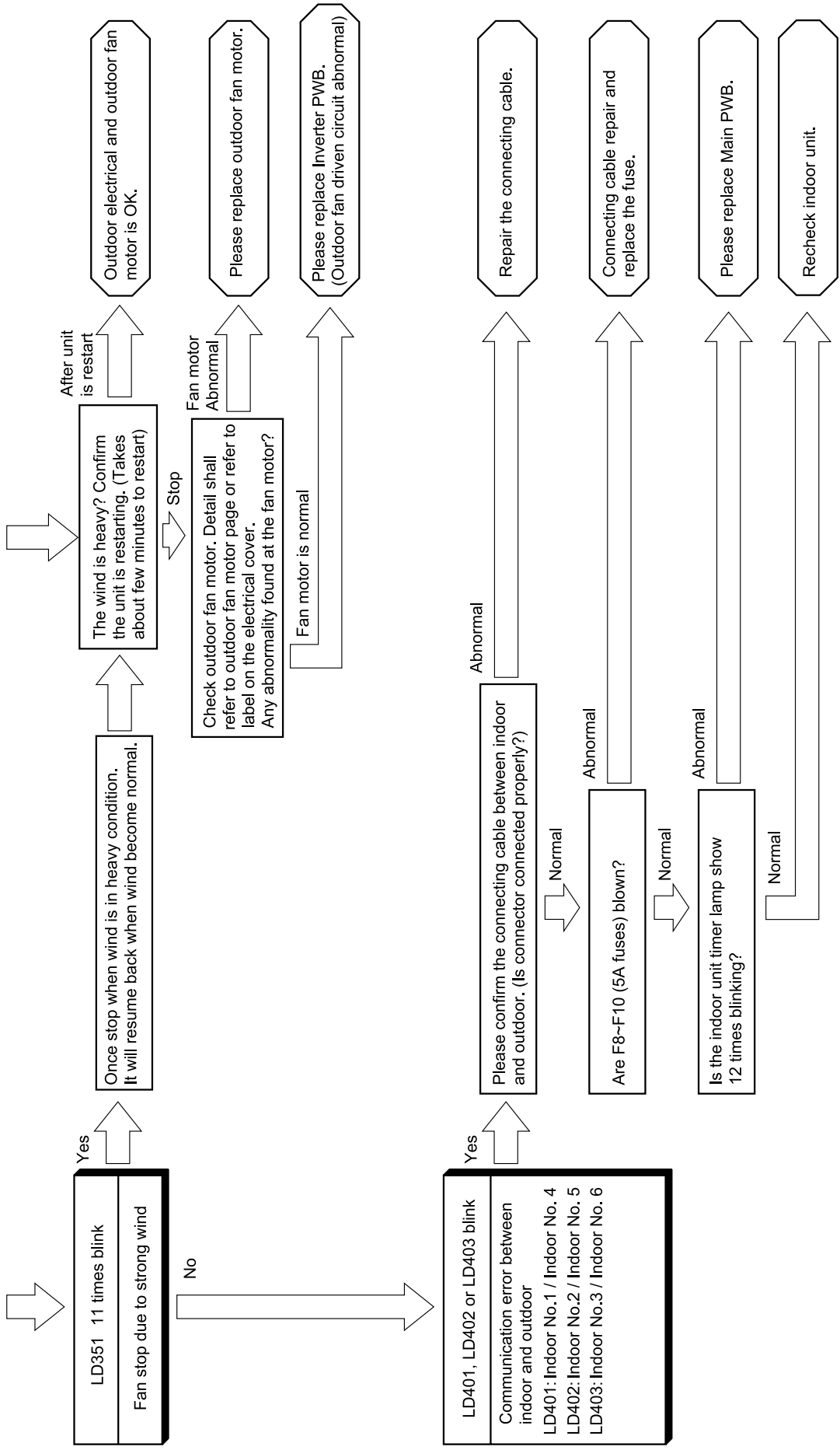

DISMANTLE AND ASSEMBLE PROCEDURE

■ RAM-110NP6B Outdoor Unit 1 (Top Side)

1. Electrical parts (preparation to remove board)

- (1) Remove screw that fix the service valve cover and push it down to take it out.
- (2) Remove the screws on both sides of top cover and then remove the top cover.

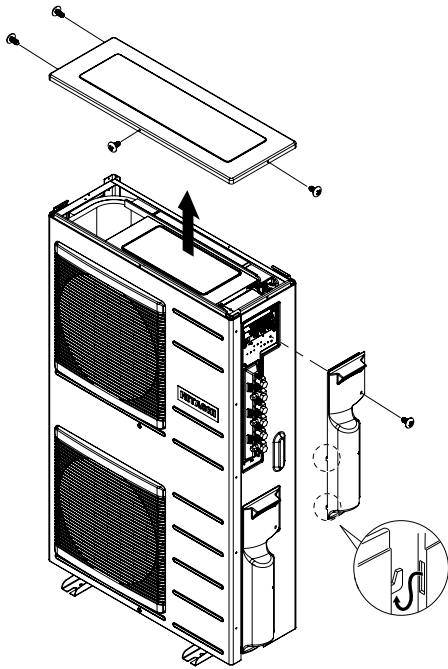

- (3) Remove the screws that holding the electrical cover and then remove the cover.

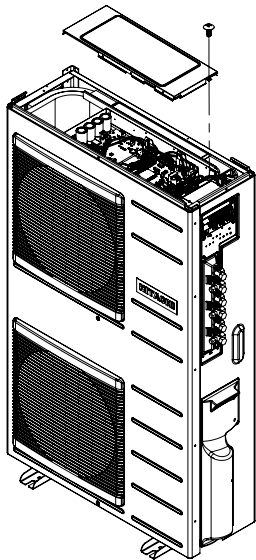

2. Dismantle procedure of inverter board

- (1) Un-insert connectors (4 places) and TAB terminal (4 places).

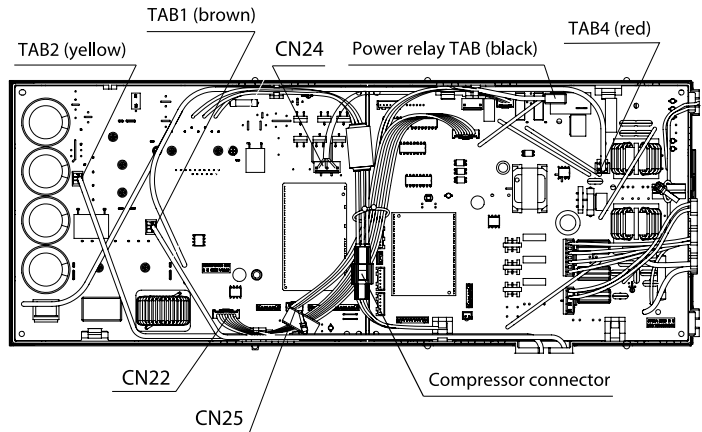

- (2) Remove screw (7 pieces) that fixed the board.

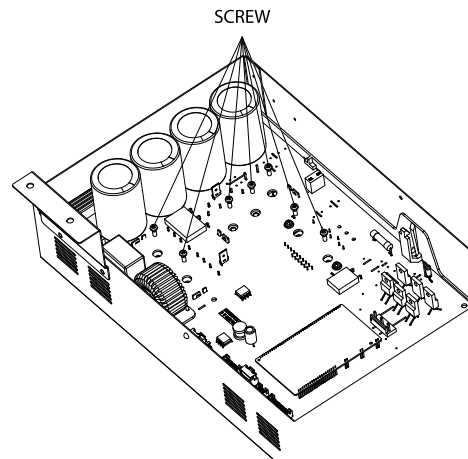

- (3) Take out the board by lift up after release the hook that hold the board in its place.

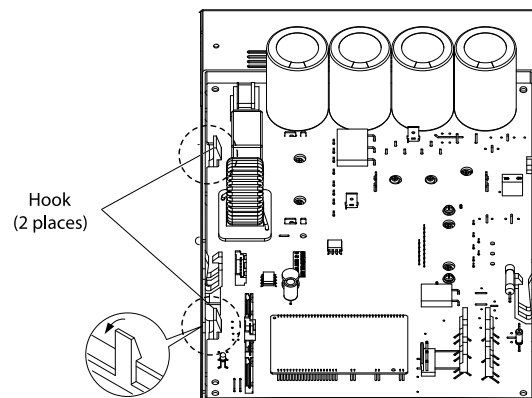

3. Dismantle procedure of main board

- (1) Un-insert connector (15 places), TAB terminal (9 places) and un-screw 1 piece earth screw.

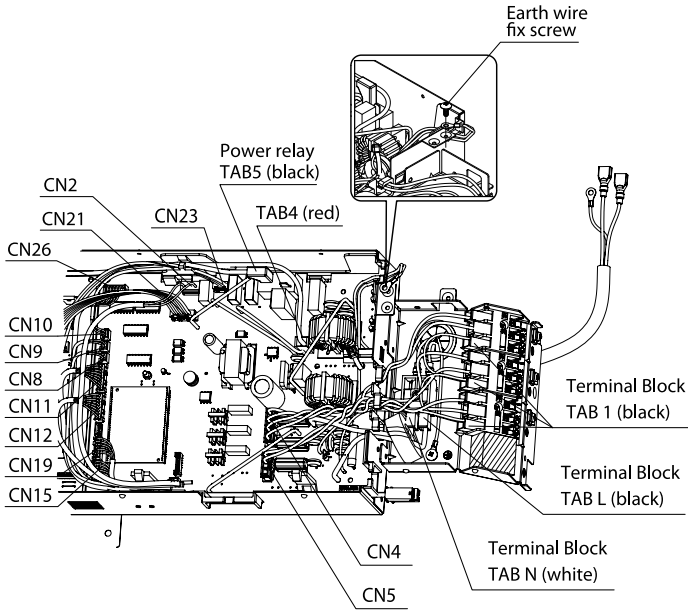

- (2) Release the hooks (2 places) that locking the board and lift up the board to take it out.

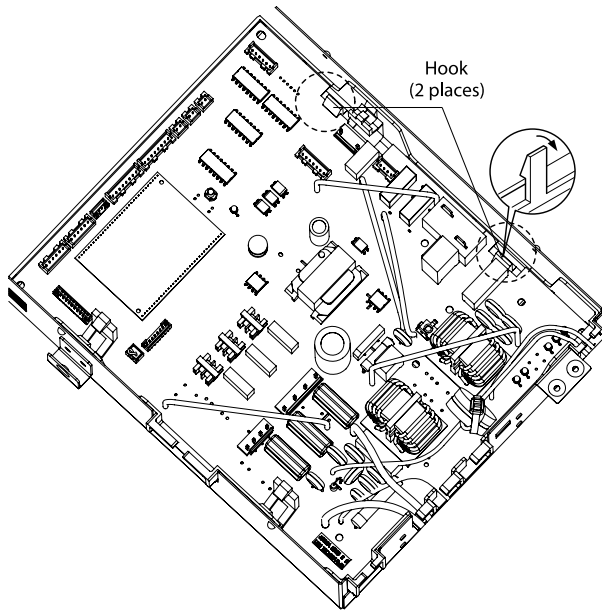

4. Assembly procedure of inverter board

- (1) Preparation before insert back the board.
Applied uniformly with small amount to 6 places of electronic part at back side of board.

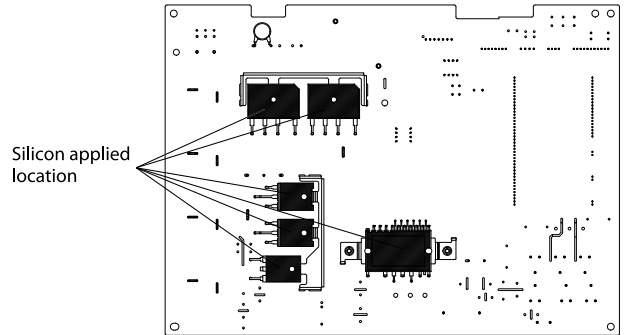

- (2) Insert the board into the pcb support and fix it with hooks (2 places).

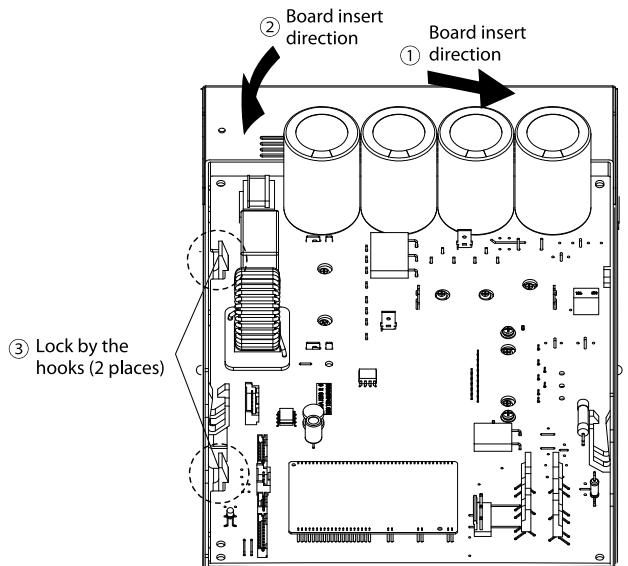

(3) Arrange the board position so that hole for fixing screw and holes at heat sink are concentric.

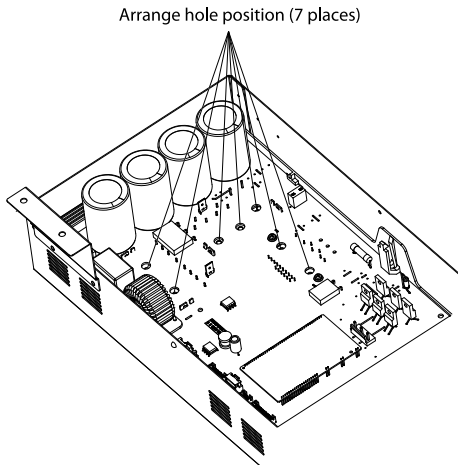

(4) Fix the board with screw (7 places).

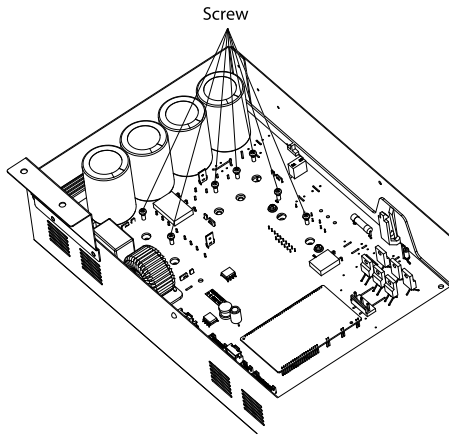

(5) Insert back connector (4 places) and TAB terminal (4 places) at its original location.

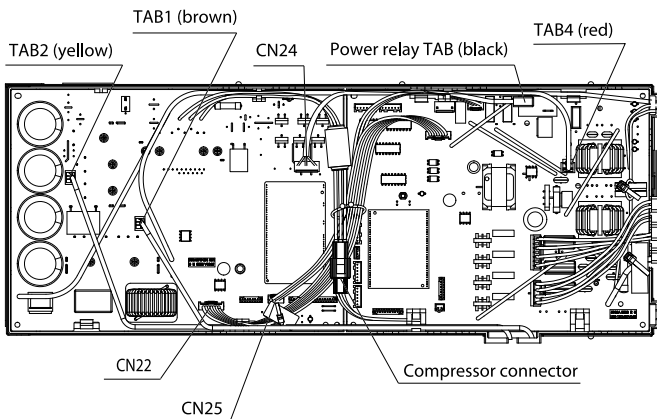

5. Assembly procedure of main board

(1) Insert back the board into pcb support and lock it with hook (3 places).

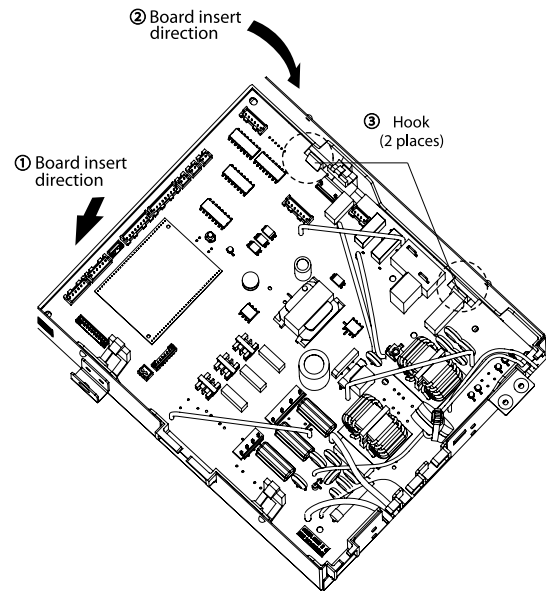

(2) Insert back the connectors (15 places), TAB terminals (9 places) and 1 piece of earth screw.

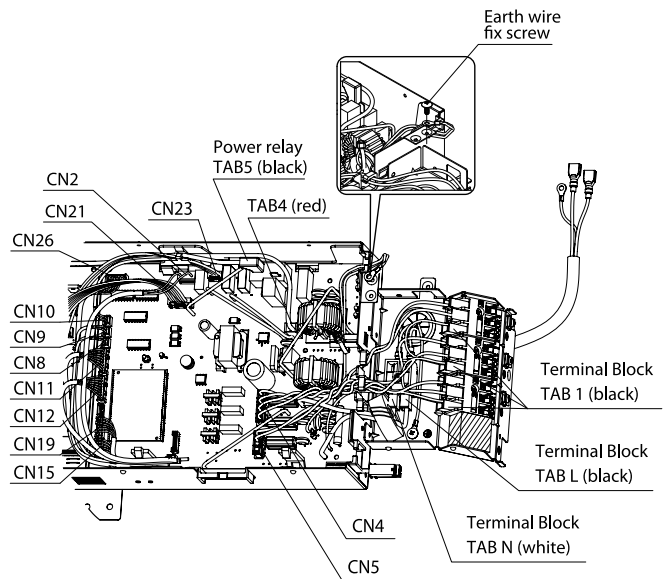

■ RAM-110NP6B Outdoor Unit 2 (Bottom Side)

1. Electrical parts (preparation to remove board)

- (1) Remove screw that fix the service valve cover and push it down to take it out.
- (2) Remove the screws on both sides of cabinet cover and then remove the cabinet cover.

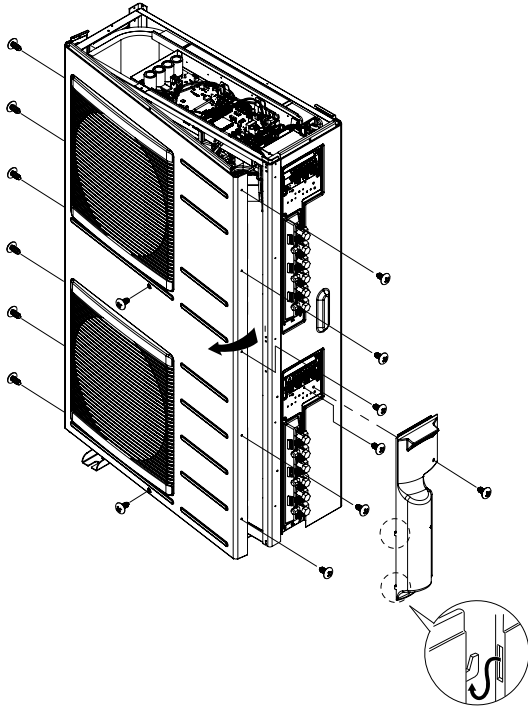

- (3) Remove the screws on middle cover sides and take it out.

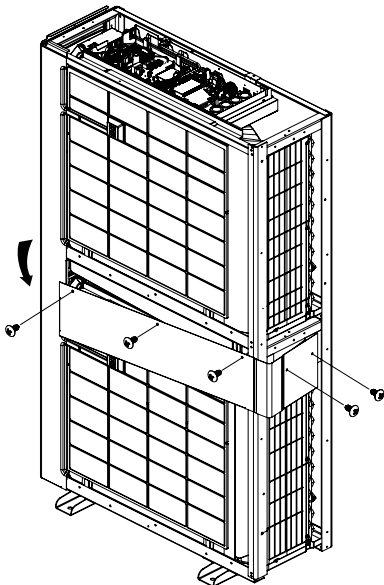

- (4) Remove the screws on L-Angle at condenser side and take it out.

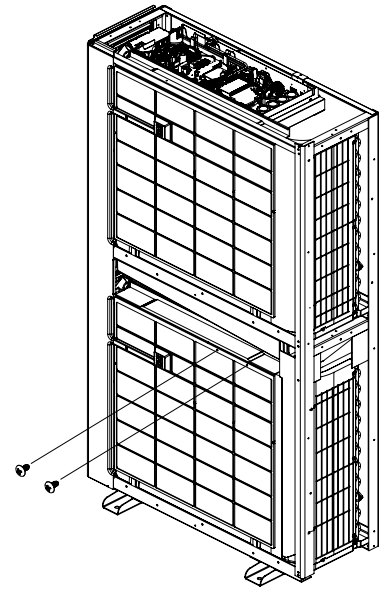

- (5) Remove the screws on L-Angle and take it out.
- (6) Remove the screws on L-Angle 2 and take it out.
- (7) Remove the screws that holding the electrical assembly at side plate.

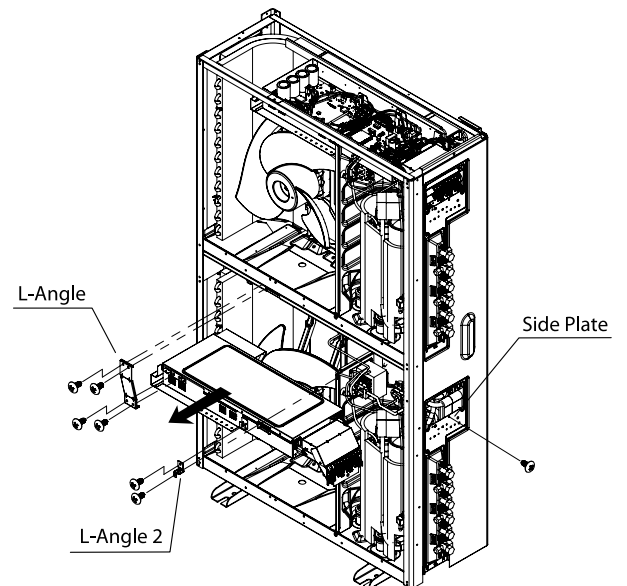

2. Dismantle procedure of inverter board

(1) Un-insert connectors (4 places) and TAB terminal (4 places).

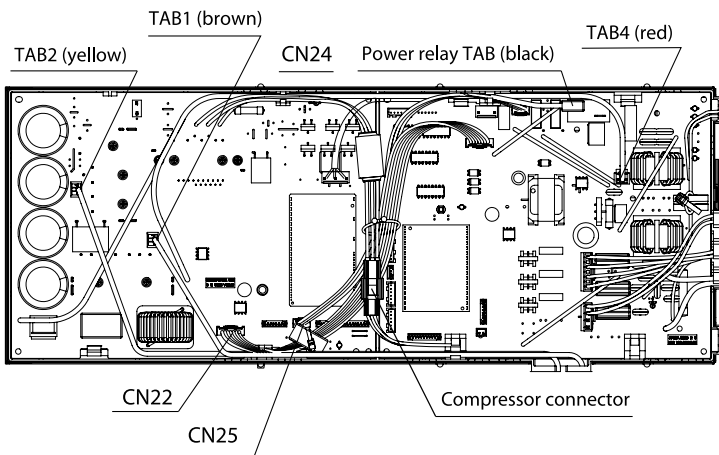

(2) Remove screws (7 pieces) that fixed the board.

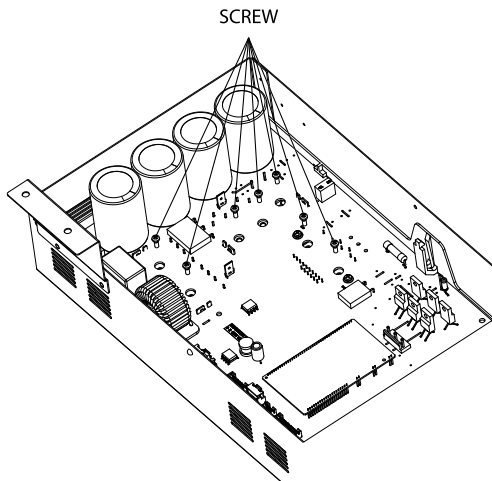

(3) Take out the board by lift up after release the hook that hold the board in its place.

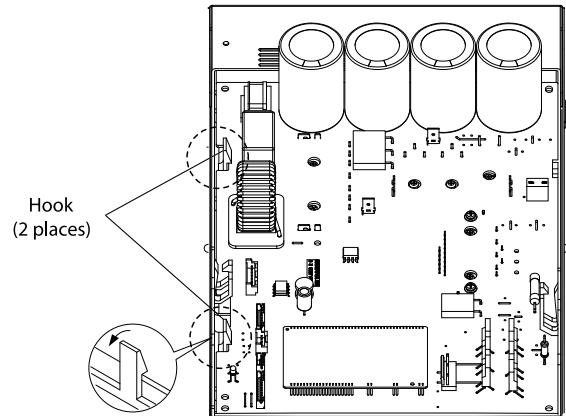

3. Dismantle procedure of main board

(1) Un-insert connector (15 places), TAB terminal (9 places) and un-screw 1 piece earth screw.

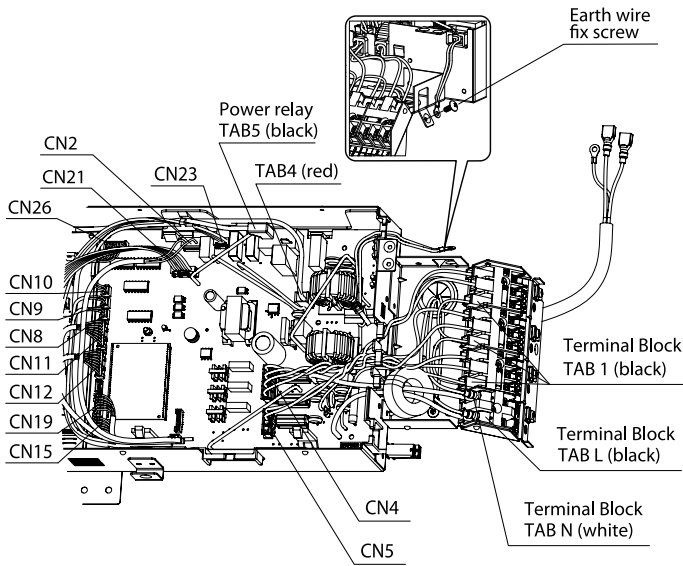

(2) Release the hooks (2 places) that locking the board and lift up the board to take it out.

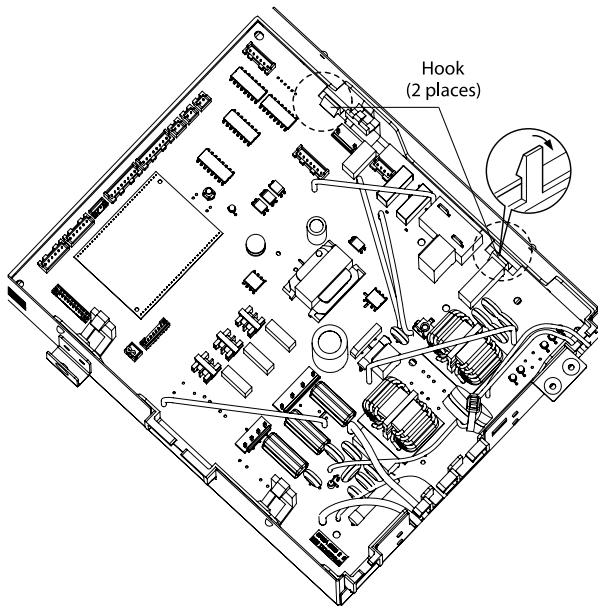

4. Assembly procedure of inverter board

(1) Preparation before insert back the board.

Applied uniformly with small amount to 6 places of electronic part at back side of board.

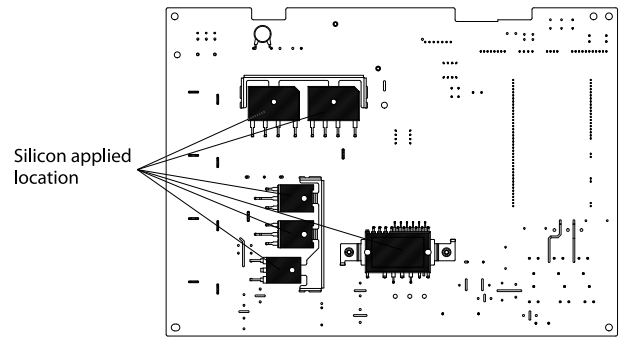

(2) Insert the board into the pcb support and fix it with hooks (2 places).

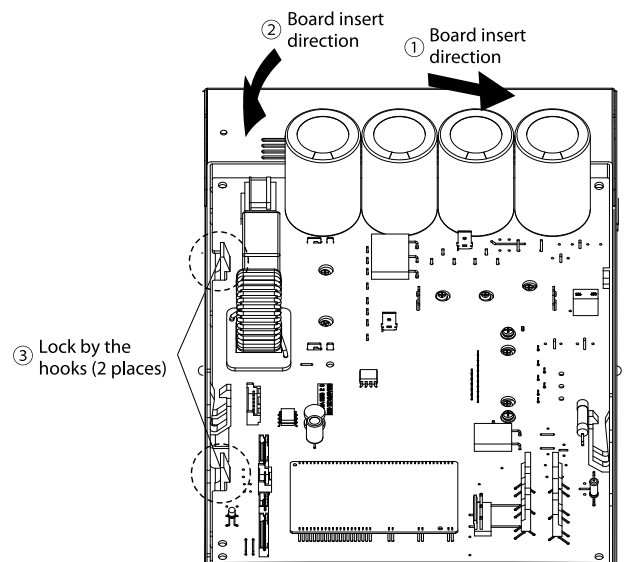

(3) Arrange the board position so that hole for fixing screw and holes at heat sink are concentric.

Arrange hole position (7 places)

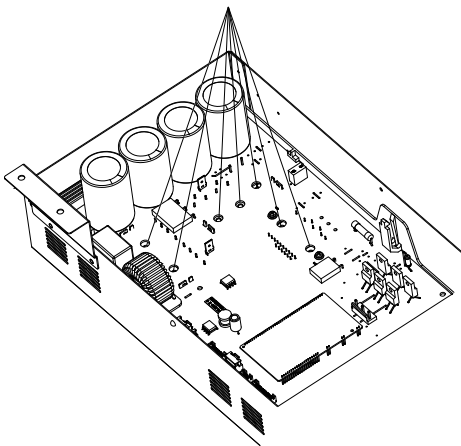

(4) Fix the board with screw (7 places).

Screw

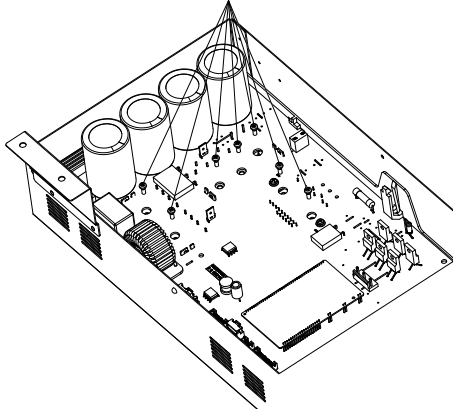

(5) Insert back connector (4 places) and TAB terminal (4 places) at it original location.

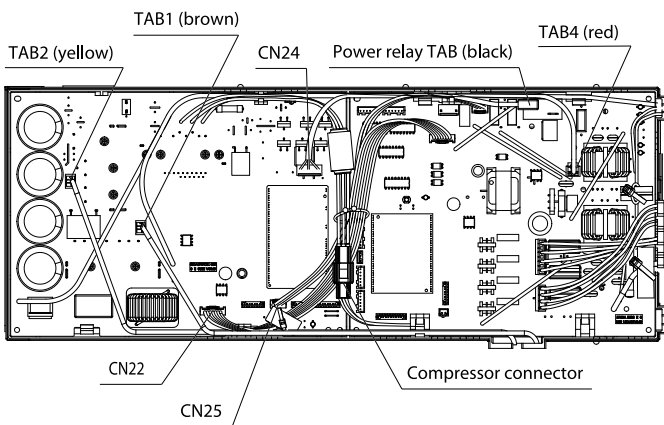

5. Assembly procedure of main board

(1) Insert back the board into pcb support and lock it with hook (3 places).

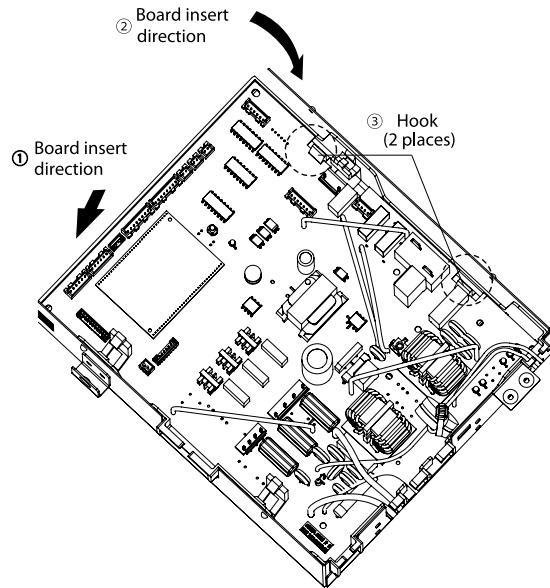

(2) Insert back the connectors (15 places), TAB terminals (9 places) and 1 piece of earth screw.

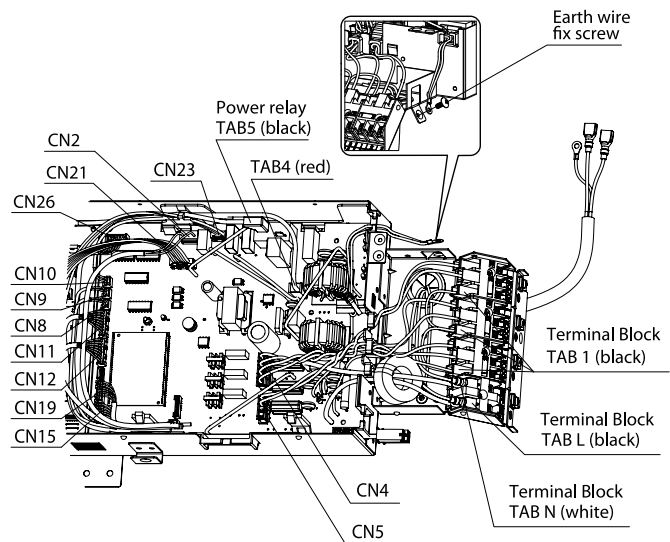

<Repairing Refrigerating Cycle>

1. Electric expansion valve

and **Service valve assembly (with valve base)**

- (1) Remove the upper plate, side plate, front cover, both side covers and electric part box.
- (2) Remove the two screws holding the partition (one on base and one on top of condenser).
- (3) Remove the support that holds the lead wire, both of which are attached to the partition.
- (4) Pull the three Electric expansion valve coils up to remove them.
- (5) Use a pipe cutter, etc. to cut off the three pipes at the side of Electric expansion valve and condenser outlet pipe.
- (6) Remove the screws holding the valve base .
- (7) Lift the valve base to remove it from the base.

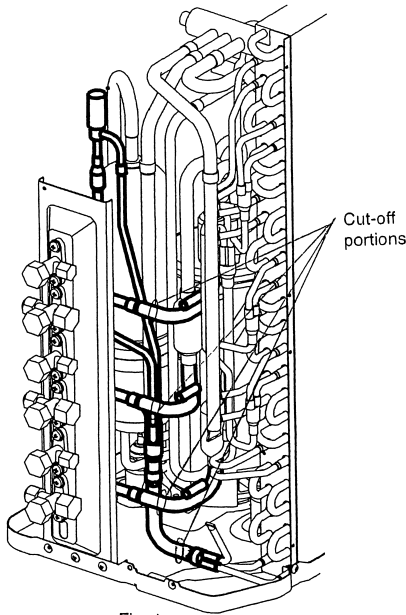

Fig. 1

2. Condenser

- (1) Remove the covers, electric part box, partition and supports (see steps (1)-(3) of item 1).
- (2) Remove the net at the back .
- (3) Cut off the condenser outlet pipe.
- (4) Cut off the condenser inlet pipe.
- (5) Remove the screws holding the condenser on both sides of base.

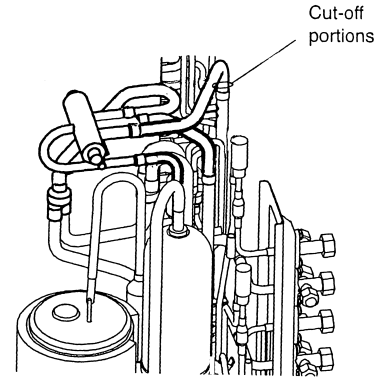

Fig. 2

3. Reversing valve

- (1) Remove the covers, electric part box, partition and supports (see steps (1)-(3) of item 1).
- (2) Remove the Reversing valve coil.
- (3) Cut off the three pipes at the side and bottom of Reversing valve.
- (4) Pull out the soldered portion of D-pipe.

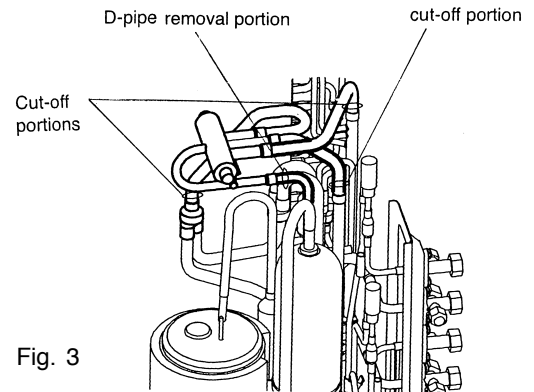
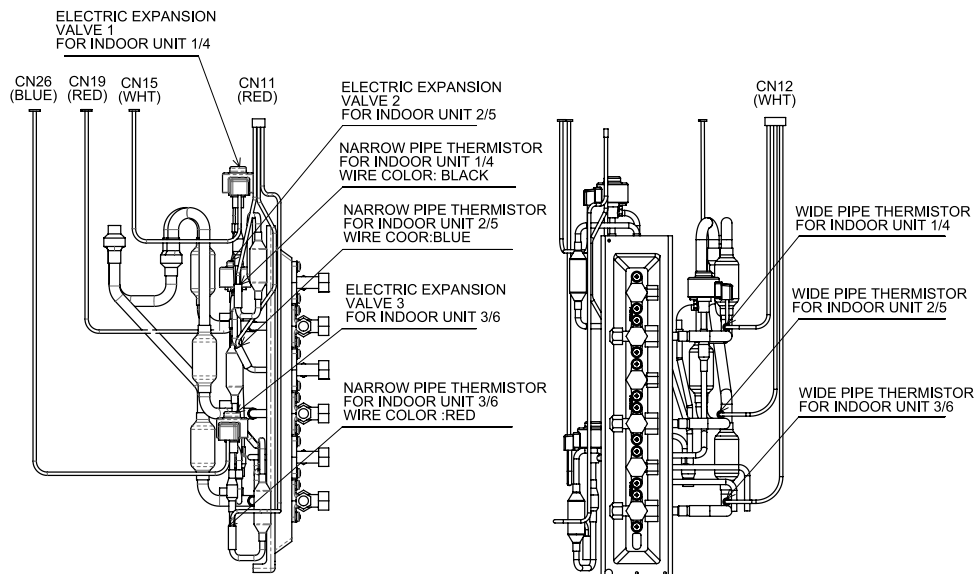

Fig. 3

ELECTRIC EXPANSION VALVE & PIPE THERMISTOR POSITION CHARTS

MODEL RAM-110NP6B



PARTS LIST AND DIAGRAM

MODEL RAM-110NP6B

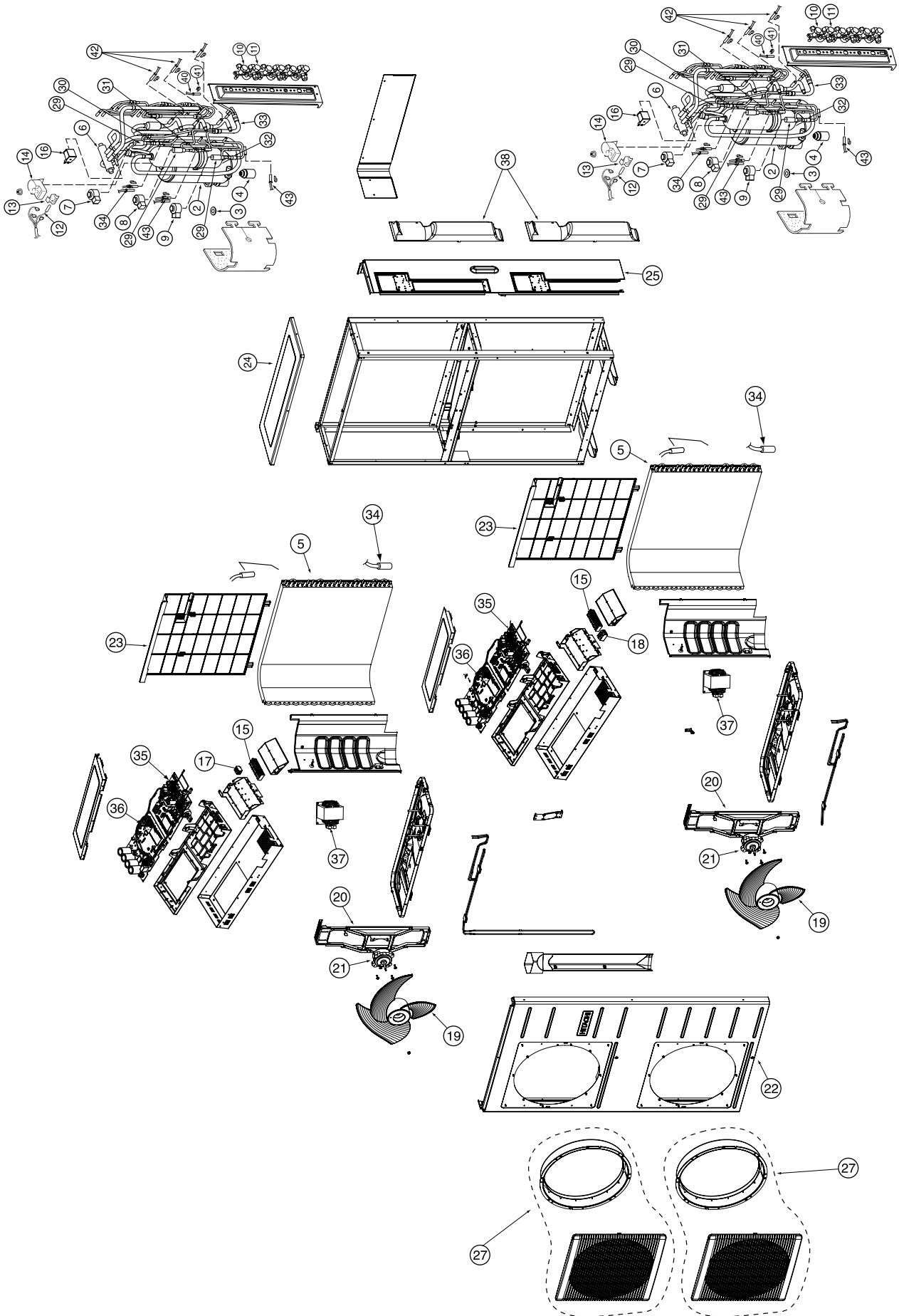

NO.	PART NO.		Q'TY / UNIT	PARTS NAME
2	PMRAC-60YH7	S01	2	COMPRESSOR
3	KPNT1	001	6	PUSH NUT
4	RAC-2226HV	805	6	COMPRESSOR RUBBER
5	PMRAC-50NH4	S02	2	CONDENSER
	PMRAM-130QH5	S15	1	CONDENSER ASSY (OPTIONAL)
6	PMRAC-S18CPA	S02	2	REVERSING VALVE
7	PMRAM-90NP5B	S03	2	EXPANSION VALVE COIL (W)
8	PMRAM-90NP5B	S04	2	EXPANSION VALVE COIL (R)
9	PMRAM-90NP5B	S05	2	EXPANSION VALVE COIL (B)
10	PMRAM-65QH4	S15	6	VALVE (2S)
11	PMRAM-65QH4	S16	6	VALVE (3S)
12	PMRAC-40CNH2	S14	2	THERMISTOR(OH)
13	PMRAC-25NH4	S09	2	THERMISTOR SUPPORT (OH)
14	PMRAC-25NH4	910	2	OLR COVER
15	PMRAC-VX13CET	S04	1	TERMINAL BOARD (3P)
16	PMRAM-90NP5B	S09	2	MG-COIL (REVERSING VALVE)
17	PMRAM-90QH5	S01	7	2P TERMINAL FOR C-D LINE
18	PMRAC-63CA1	S02	1	TERMINAL BOARD (2P)
19	PMRAC-40CNH2	S17	2	PROPELLER FAN
20	PMRAC-40CNH2	S18	2	SUPPORT (FAN MOTOR)
21	PMRAC-VX13CET	S02	2	FAN MOTOR
22	PMRAM-130QH5	903	1	CABINET
23	PMRAM-130QH5	904	2	NET
24	PMRAM-130QH5	908	1	TOP COVER
25	PMRAM-110NP6B	S03	1	SIDE PLATE R
27	PMRAC-51CHA1	S07	2	D-GRILL-AS
29	PMRAM-33NP2B	S05	6	ELECTRICAL EXPANSION VALVE
30	PMRAM-65QH4	917	2	STRAINER (ST-PIPE-AS 1)
31	PMRAM-65QH4	918	2	STRAINER (ST-PIPE-AS 2)
32	PMRAM-65QH4	919	2	STRAINER (ST-PIPE-AS 3)
33	PMRAM-53NP2A	S05	2	STRAINER (CO-PIPE-AS)
34	PMRAM-65QH4	S10	1	THERMISTOR (OUTSIDE TEMPERATURE)
35	PMRAM-110NP6B	S01	2	P.W.B. (MAIN)
36	PMRAM-110NP6B	S02	2	P.W.B. (INVERTER)
37	PMRAC-X18CD	S04	2	REACTOR
38	PMRAM-110NP6B	S04	2	SV-COVER
40	PMRAM-55QH4	S05	2	THERMISTOR (DEFROST)
41	PMRAM-72QH5	S20	2	THERMISTOR SUPPORT
42	PMRAM-53NP3B	S04	2	THERMISTOR-V (W)
43	PMRAM-53NP3B	S03	2	THERMISTOR-V (R)

HITACHI