

HITACHI

PM

NO. 0586E

RAM-90NP5B

SERVICE MANUAL TECHNICAL INFORMATION

FOR SERVICE PERSONNEL ONLY

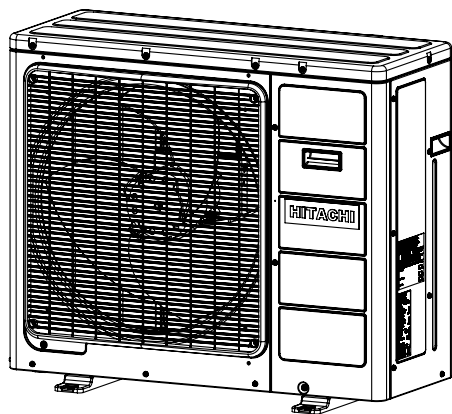

RAM-90NP5B

REFER TO THE FOUNDATION MANUAL

CONTENTS

SPECIFICATIONS-----	5
INSTALLATION-----	16
CONSTRUCTION AND DIMENSIONAL DIAGRAM-----	20
WIRING DIAGRAM-----	21
MAIN PARTS COMPONENT-----	23
CIRCUIT DIAGRAM-----	25
BLOCK DIAGRAM-----	27
PRINTED WIRING BOARD LOCATION DIAGRAM-----	28
BASIC MODE-----	33
REFRIGERATING CYCLE DIAGRAM-----	53
DESCRIPTION OF MAIN CIRCUIT OPERATION-----	54
TROUBLE SHOOTING-----	65
PARTS LIST AND DIAGRAM-----	79

SPECIFICATIONS

TYPE	DC INVERTER FIVE SYSTEM MULTI	
	OUTDOOR UNIT	
MODEL	RAM-90NP5B	
POWER SOURCE	1φ, 220 - 240V, 50/60Hz	
TOTAL INPUT (W)	REFER TO THE SPECIFICATIONS PAGE	
TOTAL AMPERES (A)		
COOLING CAPACITY (kW)		
HEATING CAPACITY (B.T.U.)		
DIMENSIONS (mm)	W	950
	H	800
	D	370
NET WEIGHT (kg)	74	

※ After installation

SPECIFICATIONS AND PARTS ARE SUBJECT TO CHANGE FOR IMPROVEMENT

ROOM AIR CONDITIONER OUTDOOR UNIT

FEBRUARY 2015 Refrigeration & Air-Conditioning Division

SAFETY DURING REPAIR WORK

1. In order to disassemble and repair the unit in question, be sure to disconnect the power cord plug from the power outlet before starting the work.

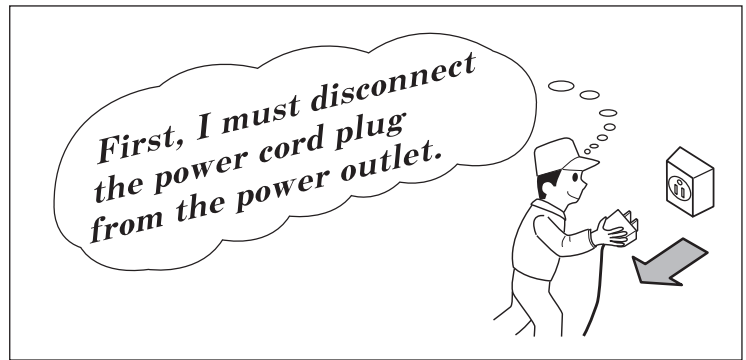

2. If it is necessary to replace any parts, they should be replaced with respective genuine parts for the unit, and the replacement must be effected in correct manner according to the instructions in the Service Manual of the unit.

If the contacts of electrical parts are defective, replace the electrical parts without trying to repair them.



3. After completion of repairs, the initial state should be restored.
4. Lead wires should be connected and laid as in the initial state.
5. Modification of the unit by the user himself should absolutely be prohibited.

6. Tools and measuring instruments for use in repairs or inspection should be accurately calibrated in advance.
7. In installing the unit having been repaired, be careful to prevent the occurrence of any accident such as electrical shock, leak of current, or bodily injury due to the drop of any part.
8. To check the insulation of the unit, measure the insulation resistance between the power cord plug and grounding terminal of the unit. The insulation resistance should be $1M\Omega$ or more as measured by a 500V DC megger.
9. The initial location of installation such as window, floor or the other should be checked for being and safe enough to support the repaired unit again.
If it is found not so strong and safe, the unit should be installed at the initial location after reinforced or at a new location.

10. Any inflammable object must not be placed about the location of installation.
11. Check the grounding to see whether it is proper or not, and if it is found improper, connect the grounding terminal to the earth.

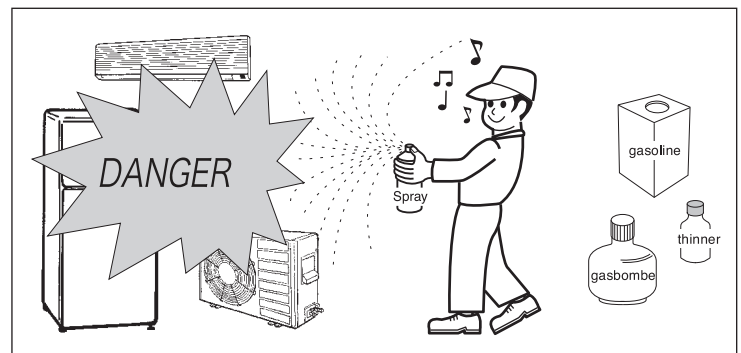

WORKING STANDARDS FOR PREVENTING BREAKAGE OF SEMICONDUCTORS

1. Scope

The standards provide for items to be generally observed in carrying and handling semiconductors in relative manufacturers during maintenance and handling thereof. (They apply the same to handling of abnormal goods such as rejected goods being returned).

2. Object parts

- (1) Micro computer
- (2) Integrated circuits (I.C.)
- (3) Field-effective transistor (F.E.T.)
- (4) P.C. boards or the like to which the parts mentioned in (1) and (2) of this paragraph are equipped.

3. Items to be observed in handling

- (1) Use a conductive container for carrying and storing of parts. (Even rejected goods should be handled in the same way).

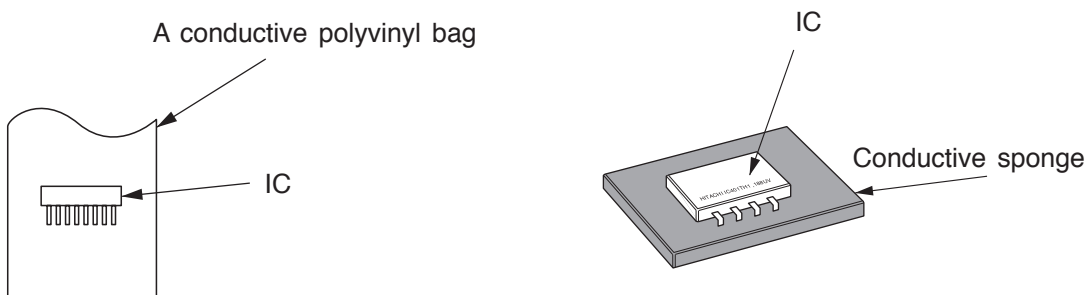

Fig. 1. Conductive container

- (2) When any part is handled uncovered (in counting, packing and the like), the handling person must always use himself as a body earth. (Make yourself a body earth by passing $1M\Omega$ earth resistance through a ring or bracelet).
- (3) Be careful not to touch the parts with your clothing when you hold a part even if a body earth is being taken.
- (4) Be sure to place a part on a metal plate with grounding.
- (5) Be careful not to fail to turn off power when you repair the printed circuit board. At the same time, try to repair the printed circuit board on a grounded metal plate.

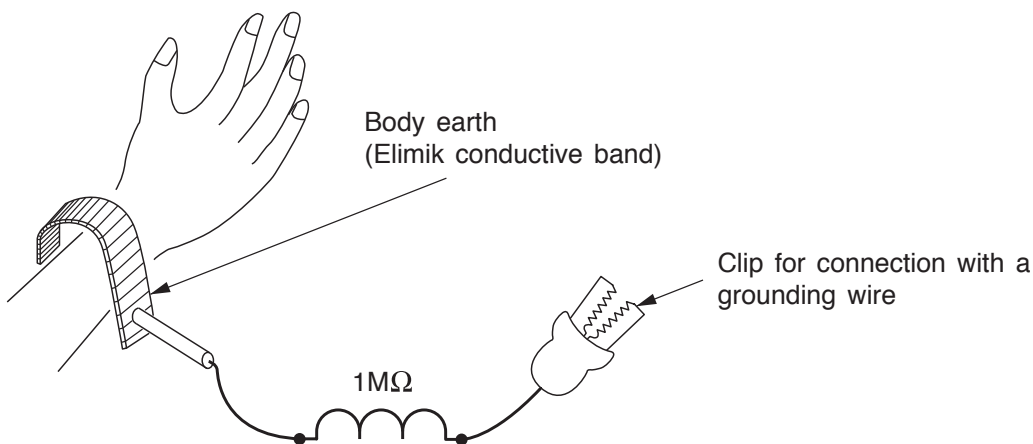

Fig. 2. Body Earth

(6) Use a three wire type soldering iron including a grounding wire.

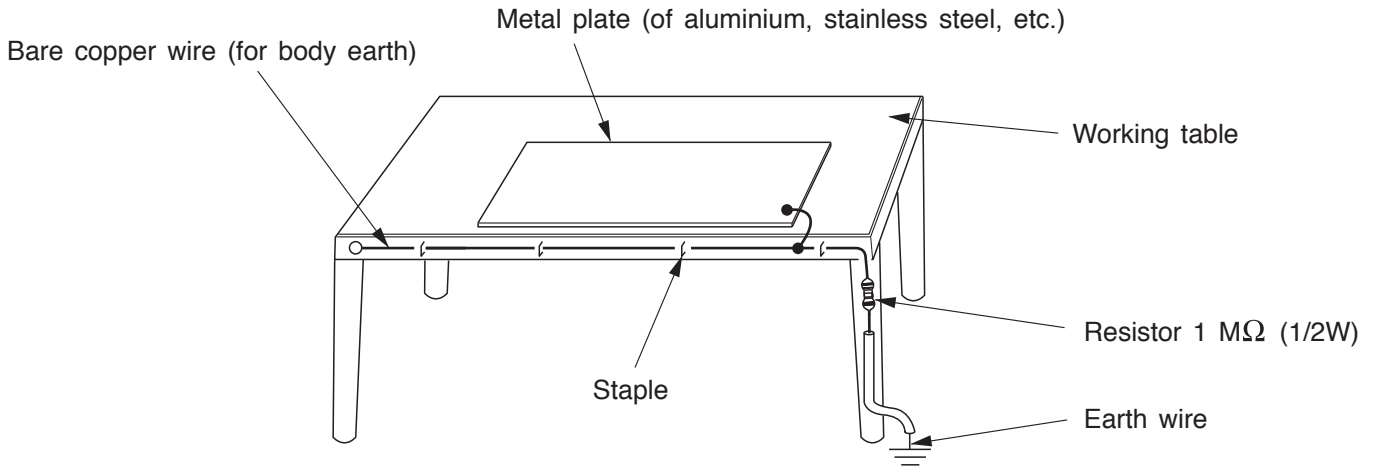

Fig. 3. Grounding of the working table

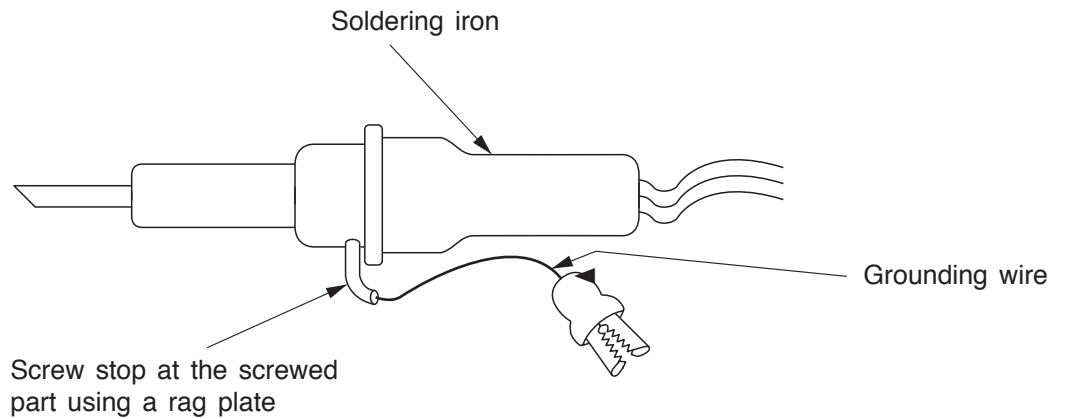

Fig. 4. Grounding a solder iron

Use a high insulation mode (100V, 10MΩ or higher) when ordinary iron is to be used.

(7) In checking circuits for maintenance, inspection or some others, be careful not to have the test probes of the measuring instrument short circuit a load circuit or the like.

 **CAUTION**

1. In quiet operation or stopping the running, slight flowing noise of refrigerant in the refrigerating cycle is heard occasionally, but this noise is not abnormal for the operation.
2. When it thunders nearby, it is recommend to stop the operation and to disconnect the power cord plug from the power outlet for safety.
3. In the event of power failure, the air conditioner will restart automatically in the previously selected mode once the power is restored. In the event of power failure during TIMER operation, the air conditioner will not start automatically. Re-press ON/OFF button after 3 minutes from when the unit off or power recovery.
4. If the room air conditioner is stopped by adjusting thermostat, or miss operation, and re-start in a moment, there is occasion that the cooling and heating operation does not start for 3 minutes, it is not abnormal and this is the result of the operation of IC delay circuit. This IC delay circuit ensures that there is no danger of blowing fuse or damaging parts even if operation is restarted accidentally.
5. This room air conditioner should not be used at the cooling operation when the outside temperature is below -10°C (14°F).
6. This room air conditioner (the reverse cycle) should not be used when the outside temperature is below -15°C (5°F).
If the reverse cycle is used under this condition, the outside heat exchanger is frosted and efficiency falls.
7. When the outside heat exchanger is frosted, the frost is melted by operating the hot gas system, it is not trouble that at this time fan stops and the vapour may rise from the outside heat exchanger.

SPECIFICATIONS

MODEL	RAM-90NP5B	
FAN MOTOR	138 W	
FAN MOTOR CAPACITOR	NO	
FAN MOTOR PROTECTOR	NO	
COMPRESSOR	JU182XC1	
COMPRESSOR MOTOR CAPACITOR	NO	
OVERLOAD PROTECTOR	YES	
OVERHEAT PROTECTOR	YES	
FUSE (for MICROPROCESSOR)	20A, 5.0A	
POWER RELAY	G4A	
POWER SWITCH	NO	
TEMPORARY SWITCH	NO	
SERVICE SWITCH (TEST SWITCH)	YES	
TRANSFORMER	NO	
VARISTOR	ERZVA9V431	
NOISE SUPPRESSOR	YES	
THERMOSTAT	YES(IC)	
REMOTE CONTROL SWITCH (LIQUID CRYSTAL)	NO	
REFRIGERANT CHARGING VOLUME (Refrigerant 410A)	UNIT	2700g
	WITHOUT REFRIGERANT BECAUSE COUPLING IS FLARE TYPE.	
	PIPES	MAX. 75m

In case the pipe length is more than 30m, add refrigerant R410 at 15gram per every meter exceeds.

SPECIFICATIONS FOR INDOOR UNITS COMBINATION

TYPE		DC INVERTER FIVE SYSTEM MULTI COOLING AND HEATING
MODEL	OUTDOOR UNIT	RAM-90NP5B
PHASE/VOLTAGE/FREQUENCY		1 ϕ , 220 - 240V, 50/60Hz
CIRCUIT AMPERES TO CONNECT (A)		25
COOLING (FIVE UNITS)	CAPACITY (kW) (B.T.U./h)	8.5
		29,020
	TOTAL INPUT (W)	2,230
	EER (B.T.U./hW)	13.01
	TOTAL AMPERES (A)	10.20 - 9.40
POWER FACTOR (%)		99
HEATING (FIVE UNITS)	CAPACITY (kW) (B.T.U./h)	11.00
		37,540
	TOTAL INPUT (W)	2,460
	EER (B.T.U./hW)	15.26
	TOTAL AMPERES (A)	11.3 - 10.4
POWER FACTOR (%)		99
MAXIMUM LENGTH OF PIPING		MAX. 75m (FIVE UNIT TOTAL)
STANDARD		CE (EMC&LVD)

MODEL		RAM-90NP5B
PACKING (mm)	W	1,037
	H	896
	D	417
	cu.ft.	13.68
GROSS WEIGHT (kg)		75
FLARE NUT SIZE (SMALL/LARGE)		6.35DX5/9.52DX3/12.70X2

OPERATION SCOPE

	INDOOR SUCTION TEMPERATURE (°C)	OUTDOOR SUCTION TEMPERATURE (°C)	INDOOR SUCTION HUMIDITY (%)
COOLING OPERATION SCOPE	16 - 32	-10 ~ 43	BELOW 80
HEATING OPERATION SCOPE	BELOW 27	-15 ~ 21	-

DUAL AND TRIPLE SYSTEM MULTI R.A.C. RAM-90NP5B INDOOR UNITS COMBINATIONS TO BE ABLE TO INSTALL

Two, three, four or five indoor units can be installed with one outdoor unit.
And total nominal cooling capacity should not be more than 15.5kW

NOMINAL COOLING CAPACITY (kW)	INDOOR UNIT MODEL	CAPACITY (kW) at one unit operation		SUITABLE ROOM SIZE (m ²) at one unit operation	
		COOLING	HEATING	COOLING	HEATING
1.5kW	RAK-15QPB	1.00 ~ 1.60	1.10 ~ 2.20	8 ~ 12	9 ~ 11
1.8kW	RAK-18RPB	1.50 ~ 2.00	1.80 ~ 3.50	8 ~ 12	9 ~ 11
	RAK-18QXB	1.50 ~ 2.00	1.80 ~ 3.50	8 ~ 12	9 ~ 11
	RAD-18QPB	1.50 ~ 2.00	1.80 ~ 3.50	8 ~ 12	9 ~ 11
2.5kW	RAK-25RPB	1.50 ~ 2.80	1.80 ~ 4.70	11 ~ 17	14 ~ 18
	RAK-25RXB	1.50 ~ 2.80	1.80 ~ 4.70	11 ~ 17	14 ~ 18
	RAD-25QPB	1.50 ~ 2.80	1.80 ~ 4.70	11 ~ 17	14 ~ 18
	RAI-25QPB	1.50 ~ 2.80	1.80 ~ 4.70	11 ~ 17	14 ~ 18
	RAF-25RXB	1.50 ~ 2.80	1.80 ~ 4.70	11 ~ 17	14 ~ 18
3.5kW	RAK-35RPB	1.50 ~ 3.90	1.80 ~ 5.80	16 ~ 24	17 ~ 22
	RAK-35RXB	1.50 ~ 3.90	1.80 ~ 5.80	16 ~ 24	17 ~ 22
	RAD-35QPB	1.50 ~ 3.90	1.80 ~ 5.80	16 ~ 24	17 ~ 22
	RAI-35QPB	1.50 ~ 3.90	1.80 ~ 5.80	16 ~ 24	17 ~ 22
	RAF-35RXB	1.50 ~ 3.90	1.80 ~ 5.80	16 ~ 24	17 ~ 22
5.0kW	RAK-50RPB	1.50 ~ 5.60	1.80 ~ 7.20	23 ~ 34	23 ~ 29
	RAK-50RXB	1.50 ~ 5.60	1.80 ~ 7.20	23 ~ 34	23 ~ 29
	RAD-50QPB	1.50 ~ 5.60	1.80 ~ 7.20	23 ~ 34	23 ~ 29
	RAI-50QPB	1.50 ~ 5.60	1.80 ~ 7.20	23 ~ 34	23 ~ 29
	RAF-50RXB	1.50 ~ 5.60	1.80 ~ 7.20	23 ~ 34	23 ~ 29

Be sure to connect two, three or four indoor units to this outdoor unit. If not, condensed water may drop, resulting in trouble.

1. NEW REFRIGERANT

(1) New refrigerant R410A with no harmful effect on the ozone layer

Refrigerant R410A, which does not damage the ozone layer, was adopted instead of HCFC-22 which is planned to be phased out globally by 2020.

(2) New refrigerating oil

The new refrigerant HFC-R410A is not compatible with conventional mineral oils and no lubrication can be expected with those oils. To solve this, the artificial synthetic ester oil is newly adopted.

Cautions in relation to HFC (R410A)

1. Safety during Servicing

This air conditioner uses the new refrigerant HFC (R410A) for protecting the ozone layer. R410A has several different characteristic features from HCFC-22. Therefore keep the following care items during servicing for safety.

- (1) Since the working pressure of R410A model is about 1.6 times higher than that of HCFC-22 models, it becomes necessary to use part of piping materials and servicing tools exclusive for R410A model.
- (2) It is necessary to exercise more care to prevent the foreign matters (oil, moisture, etc.) from mixing into the piping than in the case of HCFC-22 model. Also, when storing the piping, securely seal its openings with pinching and taping, etc..
- (3) Be sure to charge the refrigerant from the liquid-phase side, as the liquid-phase/gas-phase-composition changes a little in the case of R410A model.
- (4) Never use refrigerant other than R410A in an air conditioner which is designed to operate with R410A.
- (5) If a refrigeration gas leakage occurs during servicing, be sure to ventilate fully.
If the refrigerant gas comes into contact with fire, a poisonous gas may occur.
- (6) When installing or removing an air conditioner, do not allow air or moisture to remain in the refrigeration cycle. Otherwise, pressure in the refrigeration cycle may become abnormally high so that a rupture or personal injury may be caused.
- (7) After completion of service work, check to make sure that there is no refrigeration gas leakage.
If the refrigerant gas leaks into the room, coming into contact with fire in the fan-driven heater, space heater, etc., a poisonous gas may occur.

2. Refrigerant Piping Materials

(1) Thickness of Refrigerant Piping

Although the thickness is same as that for HCFC-22 model, as R410A model features higher pressure, be sure to confirm the thickness prior to use.

※Do not use thin pipes (thinner than 0.7 mm).

Nominal diameter	Outside diameter (mm)	Thickness (mm)
1/4	6.35	0.8
3/8	9.52	0.8
1/2	12.70	0.8

(2) Flare's Expansion Pipe

The projection when the new flare tool is used, is as follows. When using the conventional flare tool, be sure to secure the following projection by using a gauge for projection adjustment.

※When using the conventional flare tool, use a gauge for projection adjustment.

Projection "A"(mm) for Flare Tool for R410A (Clutch Type)

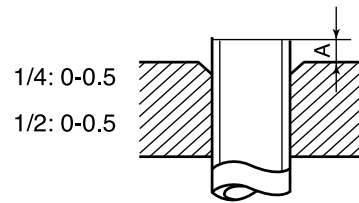

(3) Flare Nut Dimensions

Along with changes in the expansion pipe dimensions, the opposite side dimensions of flare nuts whose nominal diameter is 1/2 change so that different torque wrenches must be used.

※Figures in () denote those for HCFC-22.

Nominal diameter	Opposite Side Dimensions (mm) of Flare Nuts for R410A
1/4	17 (17)
3/8	22 (22)
1/2	26 (24)

3. Servicing Tools

(Changes in the Product and Components)

- In order to prevent any other refrigerant from being charged, R410A model is provided with the outdoor unit whose control valve has a different service port diameter (port size: 7/16 UNF 20 threads per inch → 1/2 UNF 20 threads per inch).
- In order to secure larger pressure resisting strength, flare expansion pipe dimensions and flare nut dimensions have been changed.

(New Tools for R410A)

New tools for R410A	Applicable to HCFC-22 Model	Changes
Gauge manifold	×	As pressure is high, it is impossible to measure by means of conventional gauge. In order to prevent any other refrigerant from being charged, each port diameter has been changed.
Charge hose	×	In order to increase pressure resistance, hose materials and port size have been changed (to 1/2 UNF 20 threads per inch). When purchasing a charge hose, be sure to confirm the port size.
Electronic balance for refrigerant charging	○	As pressure is high and gasification speed is fast, it is difficult to read the indicated value by means of charging cylinder, as air bubbles occur.
Torque wrench	×	The opposite side dimensions of flare nuts increase. Incidentally, a common wrench is used for nominal diameters 1/4 and 3/8.
Flare tool (clutch type)	○	By increasing the clamp bar's receiving hole, strength of spring in the tool has been improved.
Gauge for projection adjustment	—	Used when performing flare processing by means of conventional flare tool.
Vacuum pump adapter	○	Connected to conventional vacuum pump.
Gas leakage detector	×	Exclusive for HFC refrigerant.

- Incidentally, the "refrigerant cylinder" comes with the refrigerant designation (R410A) and protector coating in the U.S.'s ARI specified rose color (ARI color code: PMS 507).
- Also, the "charge port and packing for refrigerant cylinder" require 1/2 UNF 20 threads per inch corresponding to the charge hose's port size.

4. Air purging by using vacuum pump

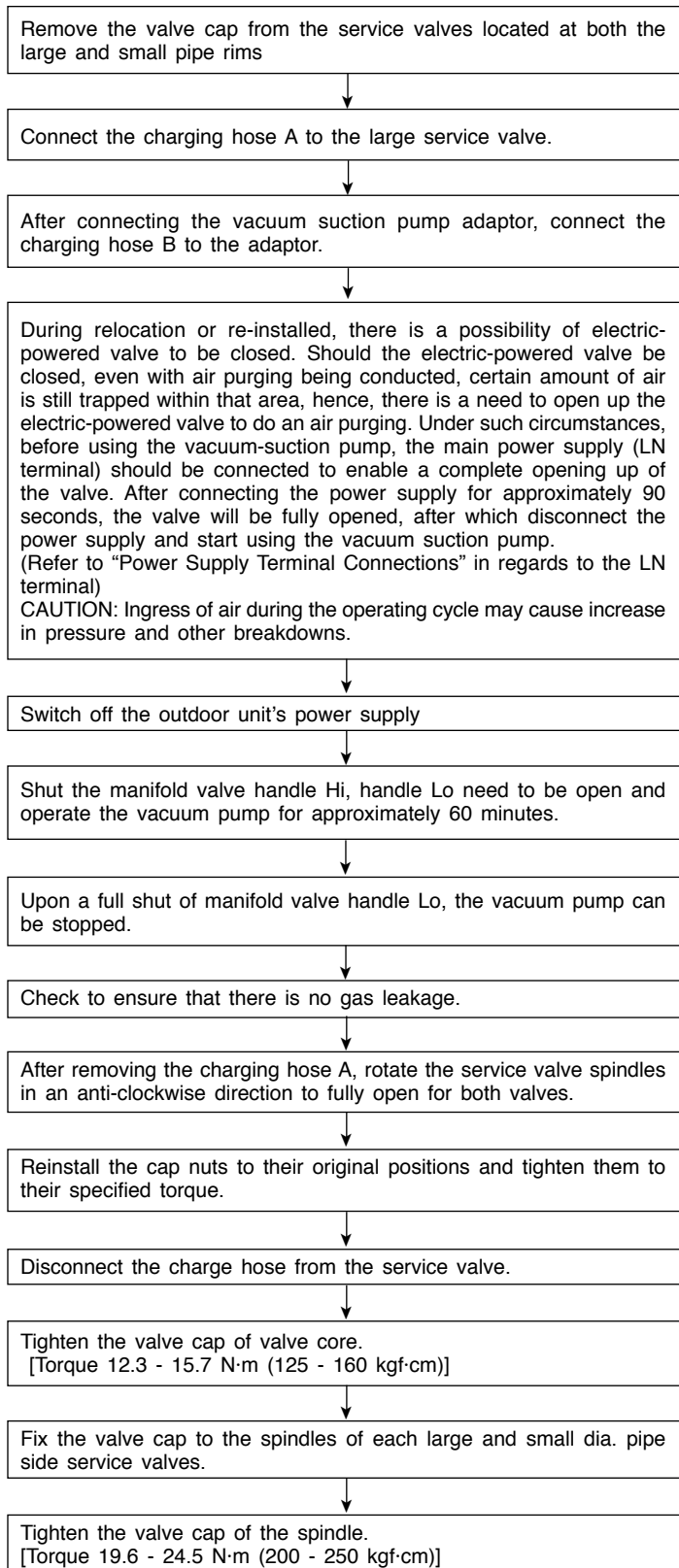

CAUTION

1. Be sure to use the vacuum pump, vacuum pump adaptor and manifold gauge and refer to their instruction manuals beforehand.
2. Ascertain that the vacuum pump is filled with oil to the level designated on the oil gauge.
3. After closed the ball valve of charge hose, it should be disconnected at service port side and refrigerant cylinder side at first. Next, after discharging the remained gas in the charge hose by opening the ball valve a little, disconnect it at manifold gauge side. You can prevent sudden release of refrigerant by connecting the ball valve to service port. And you can work more safety.

Air purging by vacuum pump

When the meter reaches -101KPa (-76cmHg) during pumping, fully tighten the shuttle.

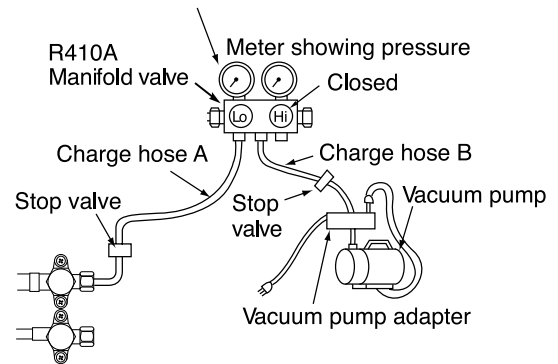

Be sure the stop valve is always fully opened.

Fig. 6-1

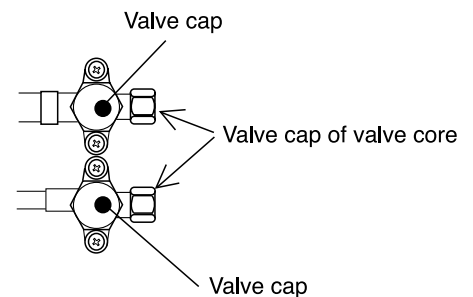

Fig. 6-2

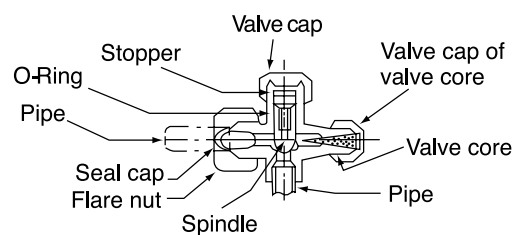

Fig. 6-3

The refrigerant channel is opened so that the refrigerant will flow from the outdoor unit into the indoor unit.

INSTALLATION

PIPE LENGTH

- (1) Total 75m maximum pipe length.
- (2) Pipe length for one indoor unit : maximum 25m.
: minimum 3m.

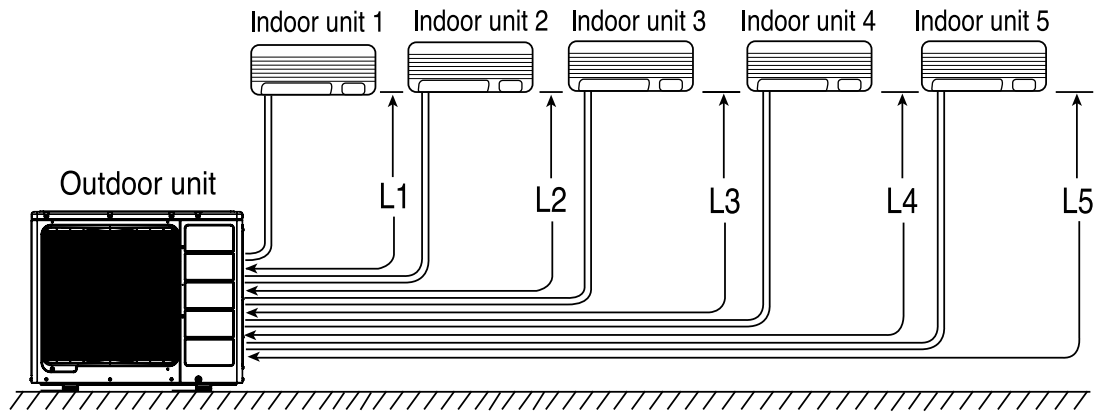

HIGHT DIFFERENCE

- (1) Height : maximum $\pm 20\text{m}$
- (2) Height difference between each indoor unit $\leq 5\text{m}$.

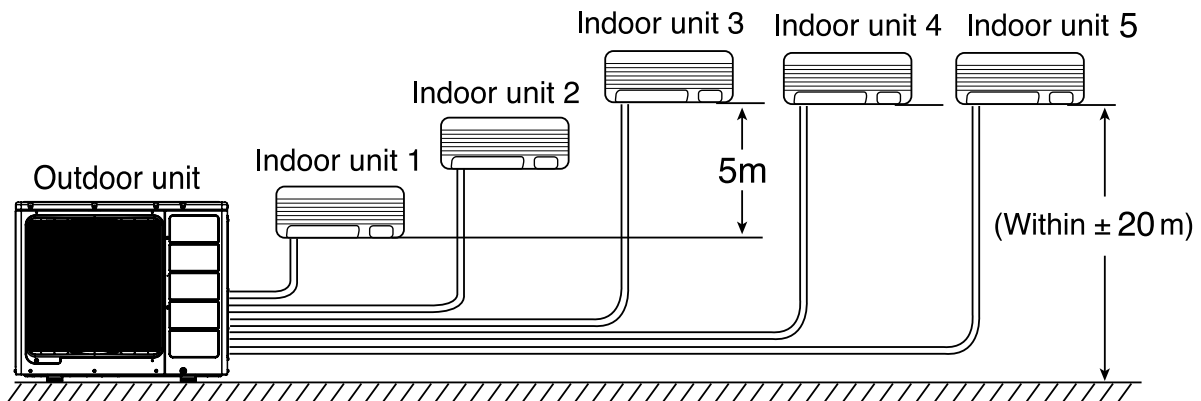

- To the outdoor unit, up to five indoor units can be connected until the total value of capacity to 15.5kW.
- Make sure to connect two or more indoor units.

MODEL: RAM-90NP5B

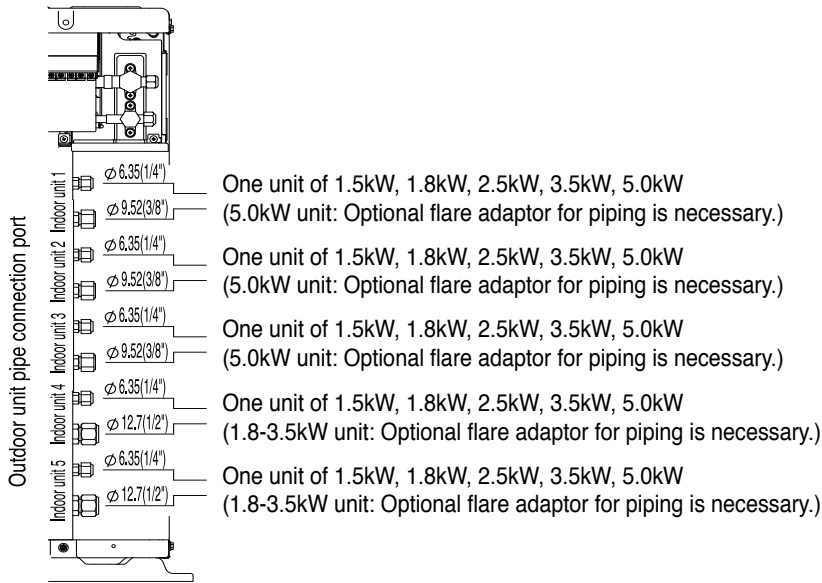

Flare adaptor for piping

The flare adaptor for piping is required depending on combination of indoor units.

- $\phi 9.52(3/8) \rightarrow \phi 12.7(1/2)$
Parts number TA261D-4 001
- $\phi 12.7(1/2) \rightarrow \phi 9.52(3/8)$
Parts number TA261D-6 002
- $\phi 12.7(1/2) \rightarrow \phi 15.88(5/8)$
Parts number TA261D-6 003

- Remove the side cover.
- For installation, refer as shown below.
- The space indicated with a \Leftrightarrow mark is required to guarantee the air conditioner's performance. Install the air conditioner in a place big enough to provide ample space for servicing and repairs later on.

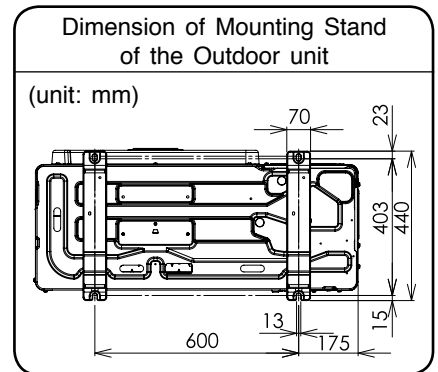
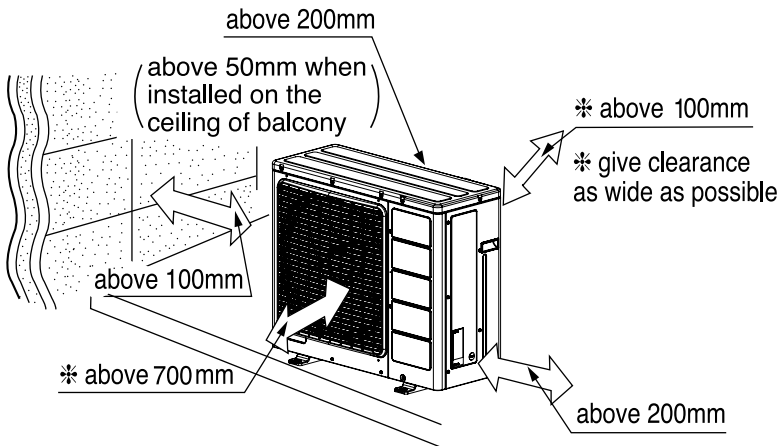

Connecting the pipe

- Install the unit in a stable place to minimize vibration or noise.
- After arranging the cord and pipes, secure them in place.

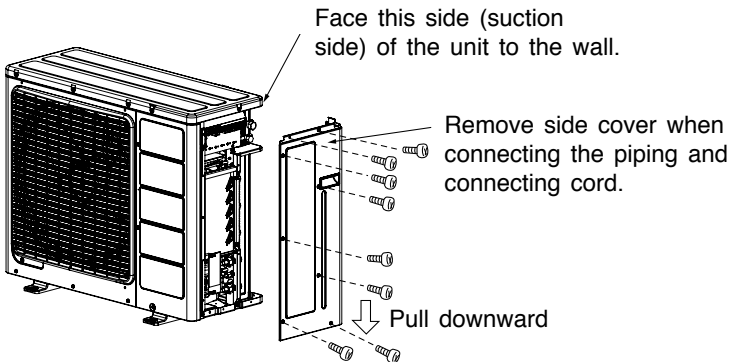

- Hold the handle of the side cover. Slide down and takeoff the corner hook, then pull. Reverse these steps when installing.

1. Remove flare nut from service valve.
2. Apply refrigerant oil to flare nut sections of service valve and pipings.
3. Match center of piping to large diameter side service valve and tank assembly, and tighten flare nut first by hand, then securely tighten using torque wrench.
4. Perform air purge and gas leak inspection.
5. Wrap the provided insulating material around side piping using vinyl tape.

Condensed water disposal of outdoor unit

- There is holes on the base of outdoor unit for condensed water to exhaust.
- To lead condensed water to the drain hole, place the outdoor unit on the mounting stand (optional) or on blocks to raise its level more than 100mm from the ground surface. Connect the drain pipe as shown in the figure. Cover two other water drain holes with the bushings included. (To install a bushing, push in both ends of the bushing so that it aligns with the drain hole.)
- When connecting the drain pipe, make sure that the bushing does not lift off or deviate from the base.
- Install the outdoor unit on a stable, flat surface and check to see that the condensed water drains.

When Using and Installing in Cold Areas

When the air conditioner is used in low temperature and in snowy conditions, water from the heat exchanger may freeze on the base surface to cause poor drainage. When using the air conditioner in such areas, do not install the bushings. Keep a minimum of 250mm between the drain hole and the ground. When using the drain pipe, consult your sales agent.

※ For more details, refer to the Installation Manual for Cold Areas.

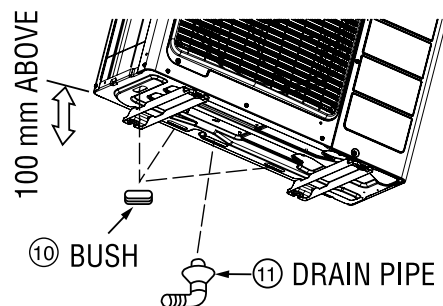
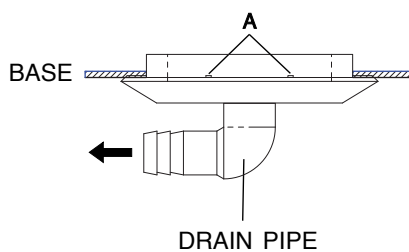

Connection of the connecting cords and power cord. (Outdoor unit)

RAM-90NP5B

⚠ WARNING

- Connecting cord should be connected according to Fig.1, that the Indoor unit No. shall match with terminal board No. of Outdoor unit.
- Be sure to fix the connecting cord with the band as shown below. Otherwise water leakage causes short circuit or faults.

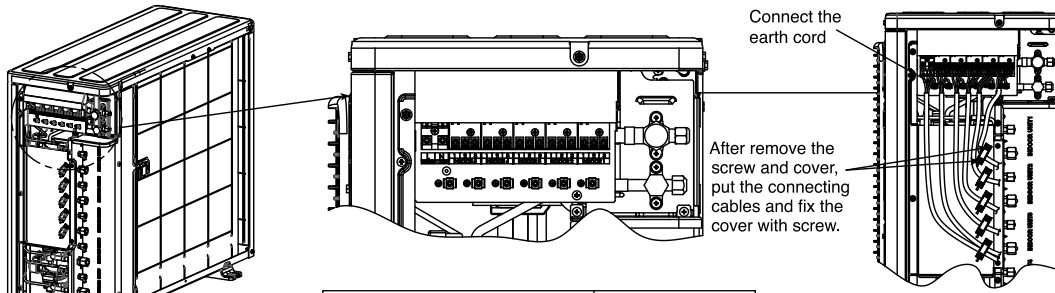

Type of grounding rod	Length
SP-EB-2	900mm

Grounding rod (optional)
(Earth wire and grounding rod are not supplied. Please use optional items below.)

⚠ CAUTION

Arrange power cord so they do not touch service valve.

⚠ WARNING

Connection of the power cord and connecting cord

Securely screw in the power cord and connecting cord so that it will not get loose or disconnect.
Tightening torque reference value: 1.2 to 1.6 N·m (12 to 16 kgf·cm)
Excessive tightening may damage the interior of the cord requiring replacement.

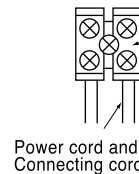

⚠ CAUTION

- To prevent a connection error, connecting cords should be bundled and taped to each respective pipe. If connecting cords are mixed with other indoor units, a refrigeration cycle abnormality may occur, causing dripping.

Wiring Pattern

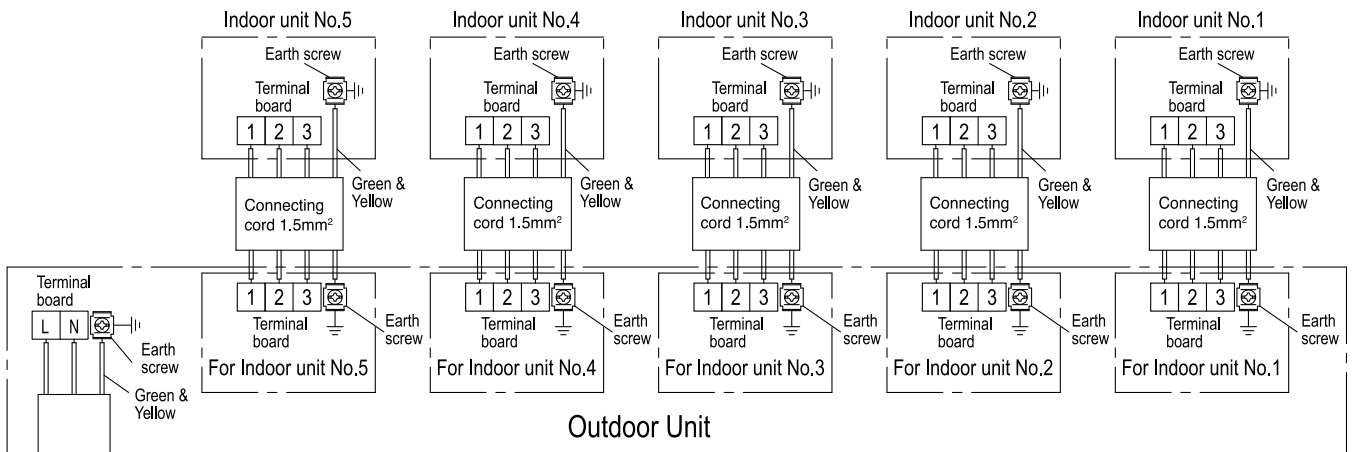
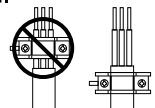

Fig. 1

⚠ WARNING

- Leave some space in the connecting cord for maintenance purpose and be sure to secure it with the cord band.
- Secure the connecting cord along the coated part of the wire using the cord band. Do not exert pressure on the wire as this may cause overheating or fire.



- Hold the handle of the side cover, slide down and take off the corner hook, then pull. Reverse these steps when installing.

CONSTRUCTION AND DIMENSIONAL DIAGRAM

MODEL RAM-90NP5B

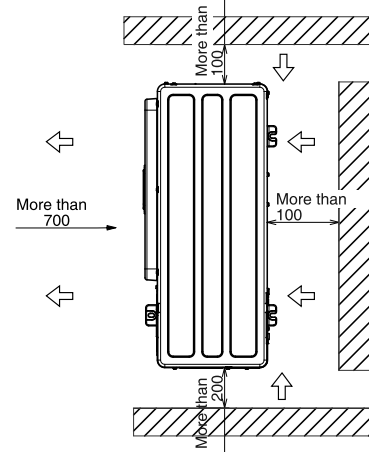
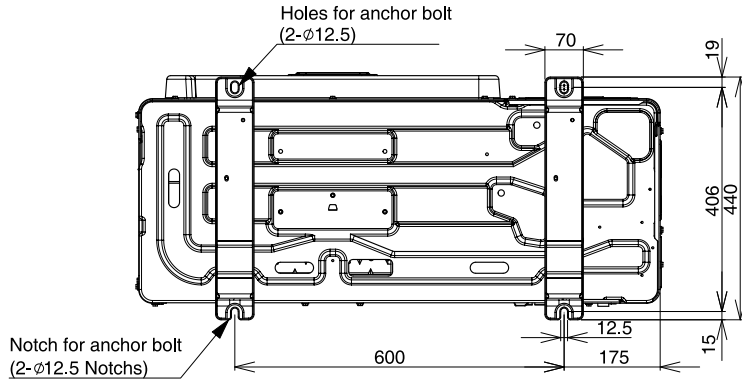
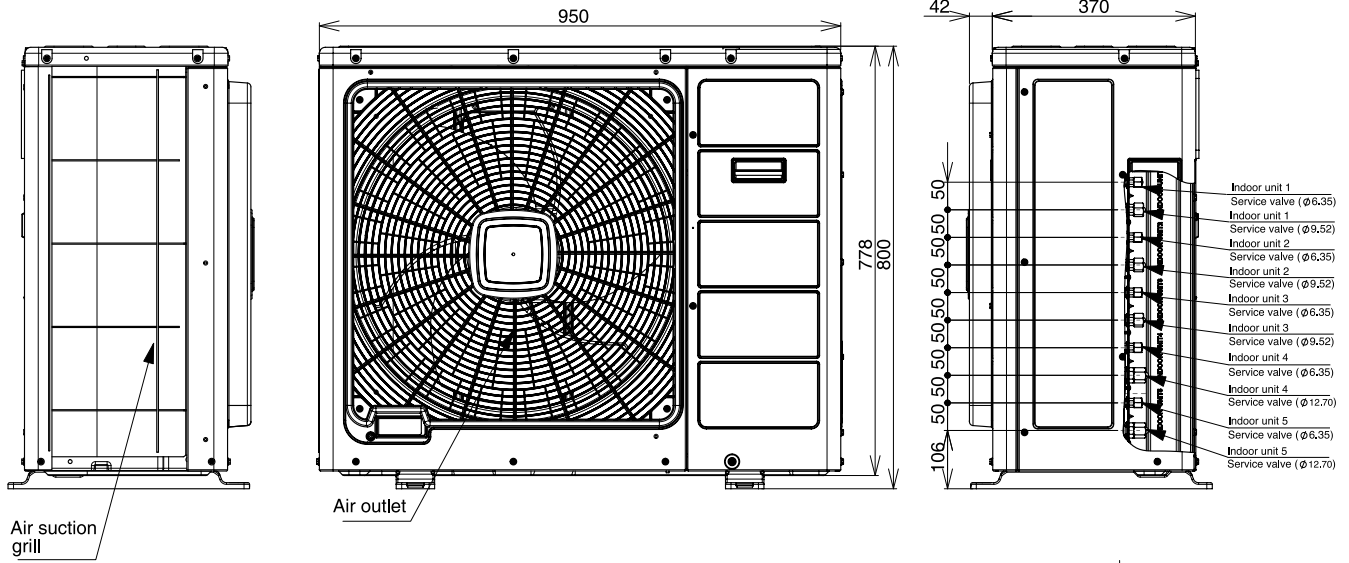

WIRING DIAGRAM

MODEL RAM-90NP5B

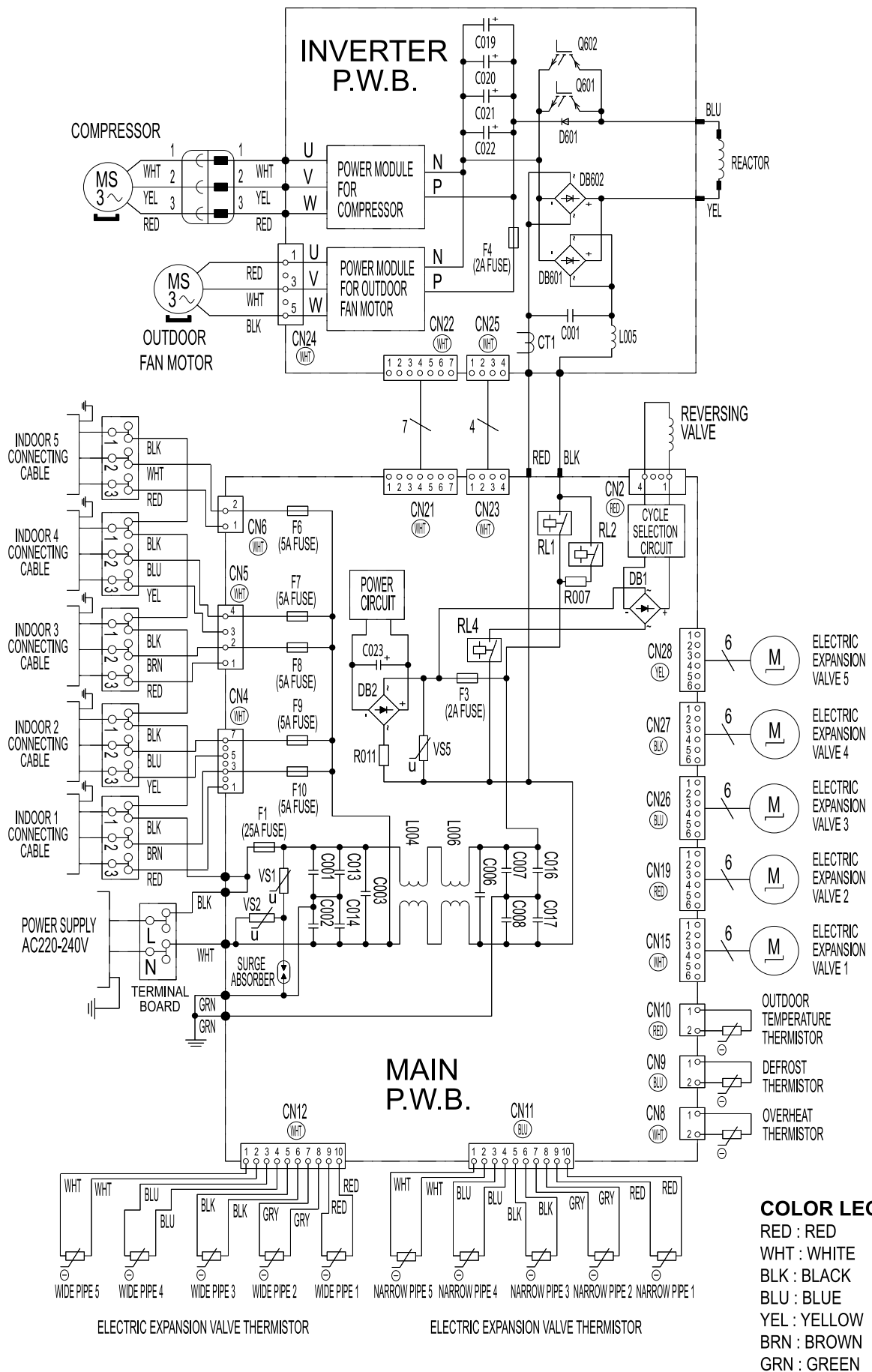

COMPRESSOR MOTOR

Compressor Motor Specifications

MODEL		RAM-90NP5B	
COMPRESSOR MODEL		JU182XC1	
PHASE		SINGLE	
RATED VOLTAGE		AC 220 ~ 240 V	
RATED FREQUENCY		50/60 Hz	
POLE NUMBER		4	
CONNECTION			
RESISTANCE VALUE (Ω)	20°C (68°F)	U-V	0.410
		V-W	0.397
		W-U	0.390
	75°C (167°F)	U-V	0.499
		V-W	0.483
		W-U	0.474

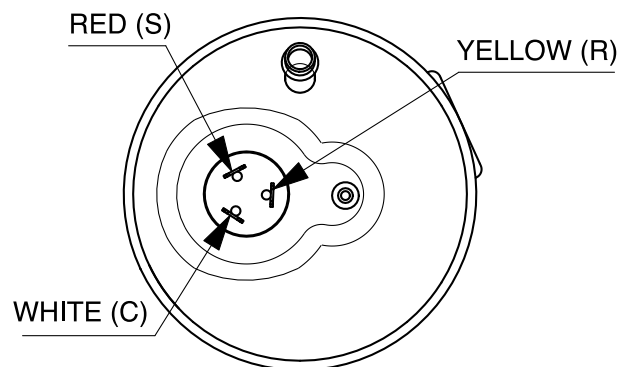

MAIN PARTS COMPONENT

FAN MOTOR

Fan Motor Specifications

MODEL		RAM-90NP5B
POWER SOURCE		DC : 280V
OUTPUT		138W
CONNECTION		
RESISTANCE VALUE ()	20°C (68°F)	U-V: 18.86 ± 1.9Ω V-W: 18.86 ± 1.9Ω W-U: 18.86 ± 1.9Ω

BLU : BLUE

YEL : YELLOW

BRN : BROWN

WHT : WHITE

GRY : GRAY

ORN : ORANGE

GRN : GREEN

RED : RED

BLK : BLACK

PNK : PINK

VIO : VIOLET

CIRCUIT DIAGRAM MODEL RAM-90NP5B

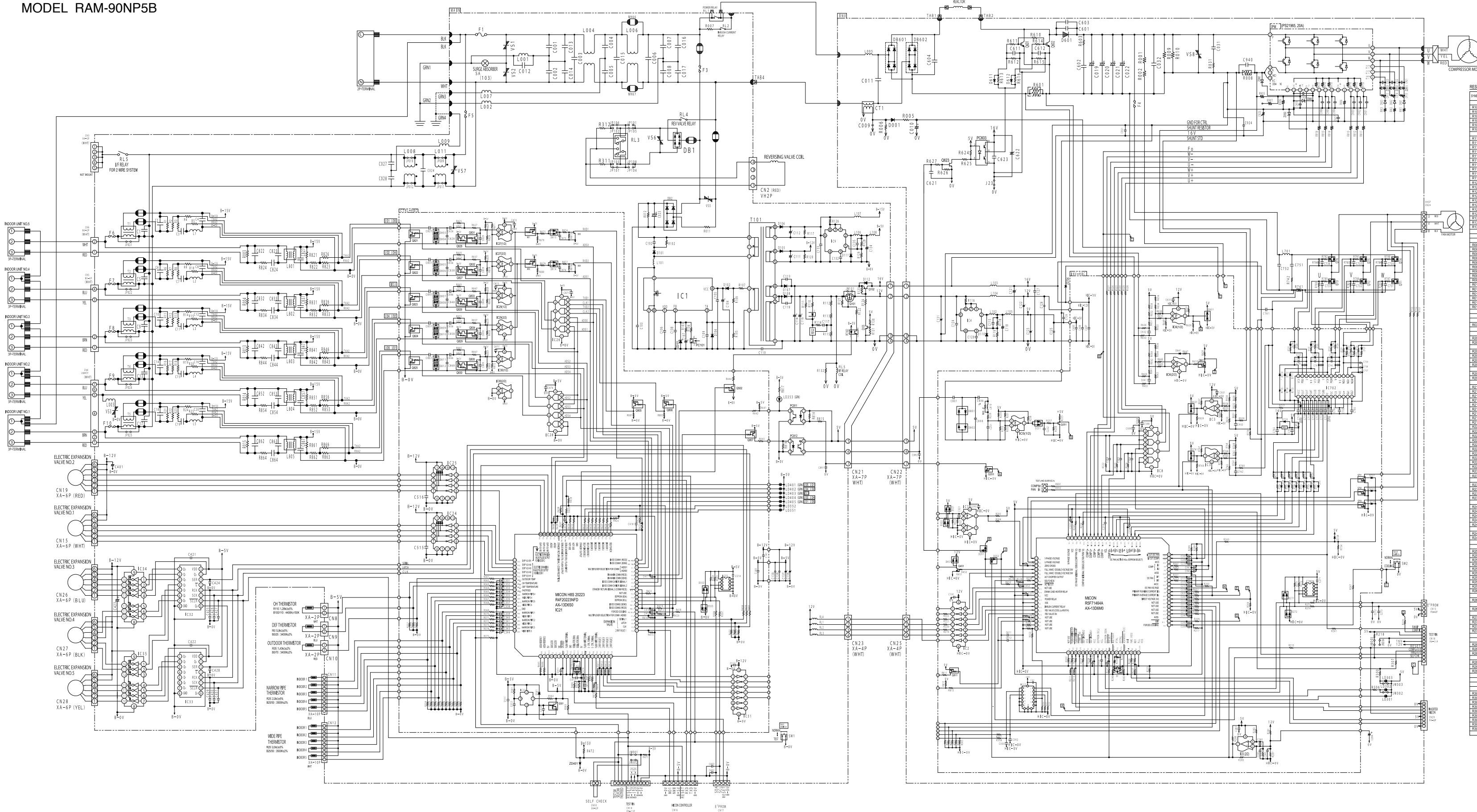

RESISTOR			CAPACITOR			DIODE			TRANSISTOR			REGULATOR		
SWAN	MODEL	VALUES	SWAN	MODEL	VALUES	SWAN	MODEL	VALUES	SWAN	MODEL	VALUES	SWAN	MODEL	VALUES
R101	330	Ω	C101	1000	μF	D101	1N4007	A	T101	2N3055	A	R101	250	Ω
R102	100	Ω	C102	1000	μF	D102	1N4007	A	T102	2N3055	A	R102	250	Ω
R103	100	Ω	C103	1000	μF	D103	1N4007	A	T103	2N3055	A	R103	250	Ω
R104	100	Ω	C104	1000	μF	D104	1N4007	A	T104	2N3055	A	R104	250	Ω
R105	100	Ω	C105	1000	μF	D105	1N4007	A	T105	2N3055	A	R105	250	Ω
R106	100	Ω	C106	1000	μF	D106	1N4007	A	T106	2N3055	A	R106	250	Ω
R107	100	Ω	C107	1000	μF	D107	1N4007	A	T107	2N3055	A	R107	250	Ω
R108	100	Ω	C108	1000	μF	D108	1N4007	A	T108	2N3055	A	R108	250	Ω
R109	100	Ω	C109	1000	μF	D109	1N4007	A	T109	2N3055	A	R109	250	Ω
R110	100	Ω	C110	1000	μF	D110	1N4007	A	T110	2N3055	A	R110	250	Ω
R111	100	Ω	C111	1000	μF	D111	1N4007	A	T111	2N3055	A	R111	250	Ω
R112	100	Ω	C112	1000	μF	D112	1N4007	A	T112	2N3055	A	R112	250	Ω
R113	100	Ω	C113	1000	μF	D113	1N4007	A	T113	2N3055	A	R113	250	Ω
R114	100	Ω	C114	1000	μF	D114	1N4007	A	T114	2N3055	A	R114	250	Ω
R115	100	Ω	C115	1000	μF	D115	1N4007	A	T115	2N3055	A	R115	250	Ω
R116	100	Ω	C116	1000	μF	D116	1N4007	A	T116	2N3055	A	R116	250	Ω
R117	100	Ω	C117	1000	μF	D117	1N4007	A	T117	2N3055	A	R117	250	Ω
R118	100	Ω	C118	1000	μF	D118	1N4007	A	T118	2N3055	A	R118	250	Ω
R119	100	Ω	C119	1000	μF	D119	1N4007	A	T119	2N3055	A	R119	250	Ω
R120	100	Ω	C120	1000	μF	D120	1N4007	A	T120	2N3055	A	R120	250	Ω
R121	100	Ω	C121	1000	μF	D121	1N4007	A	T121	2N3055	A	R121	250	Ω
R122	100	Ω	C122	1000	μF	D122	1N4007	A	T122	2N3055	A	R122	250	Ω
R123	100	Ω	C123	1000	μF	D123	1N4007	A	T123	2N3055	A	R123	250	Ω
R124	100	Ω	C124	1000	μF	D124	1N4007	A	T124	2N3055	A	R124	250	Ω
R125	100	Ω	C125	1000	μF	D125	1N4007	A	T125	2N3055	A	R125	250	Ω
R126	100	Ω	C126	1000	μF	D126	1N4007	A	T126	2N3055	A	R126	250	Ω
R127	100	Ω	C127	1000	μF	D127	1N4007	A	T127	2N3055	A	R127	250	Ω
R128	100	Ω	C128	1000	μF	D128	1N4007	A	T128	2N3055	A	R128	250	Ω
R129	100	Ω	C129	1000	μF	D129	1N4007	A	T129	2N3055	A	R129	250	Ω
R130	100	Ω	C130	1000	μF	D130	1N4007	A	T130	2N3055	A	R130	250	Ω
R131	100	Ω	C131	1000	μF	D131	1N4007	A	T131	2N3055	A	R131	250	Ω
R132	100	Ω	C132	1000	μF	D132	1N4007	A	T132	2N3055	A	R132	250	Ω
R133	100	Ω	C133	1000	μF	D133	1N4007	A	T133	2N3055	A	R133	250	Ω
R134	100	Ω	C134	1000	μF	D134	1N4007	A	T134	2N3055	A	R134	250	Ω
R135	100	Ω	C135	1000	μF	D135	1N4007	A	T135	2N3055	A	R135	250	Ω
R136	100	Ω	C136	1000	μF	D136	1N4007	A	T136	2N3055	A	R136	250	Ω
R137	100	Ω	C137	1000	μF	D137	1N4007	A	T137	2N3055	A	R137	250	Ω
R138	100	Ω	C138	1000	μF	D138	1N4007	A	T138	2N3055	A	R138	250	Ω
R139	100	Ω	C139	1000	μF	D139	1N4007	A	T139	2N3055	A	R139	250	Ω
R140	100	Ω	C140	1000	μF	D140	1N4007	A	T140	2N3055	A	R140	250	Ω

BLOCK DIAGRAM
MODEL RAM-90NP5B

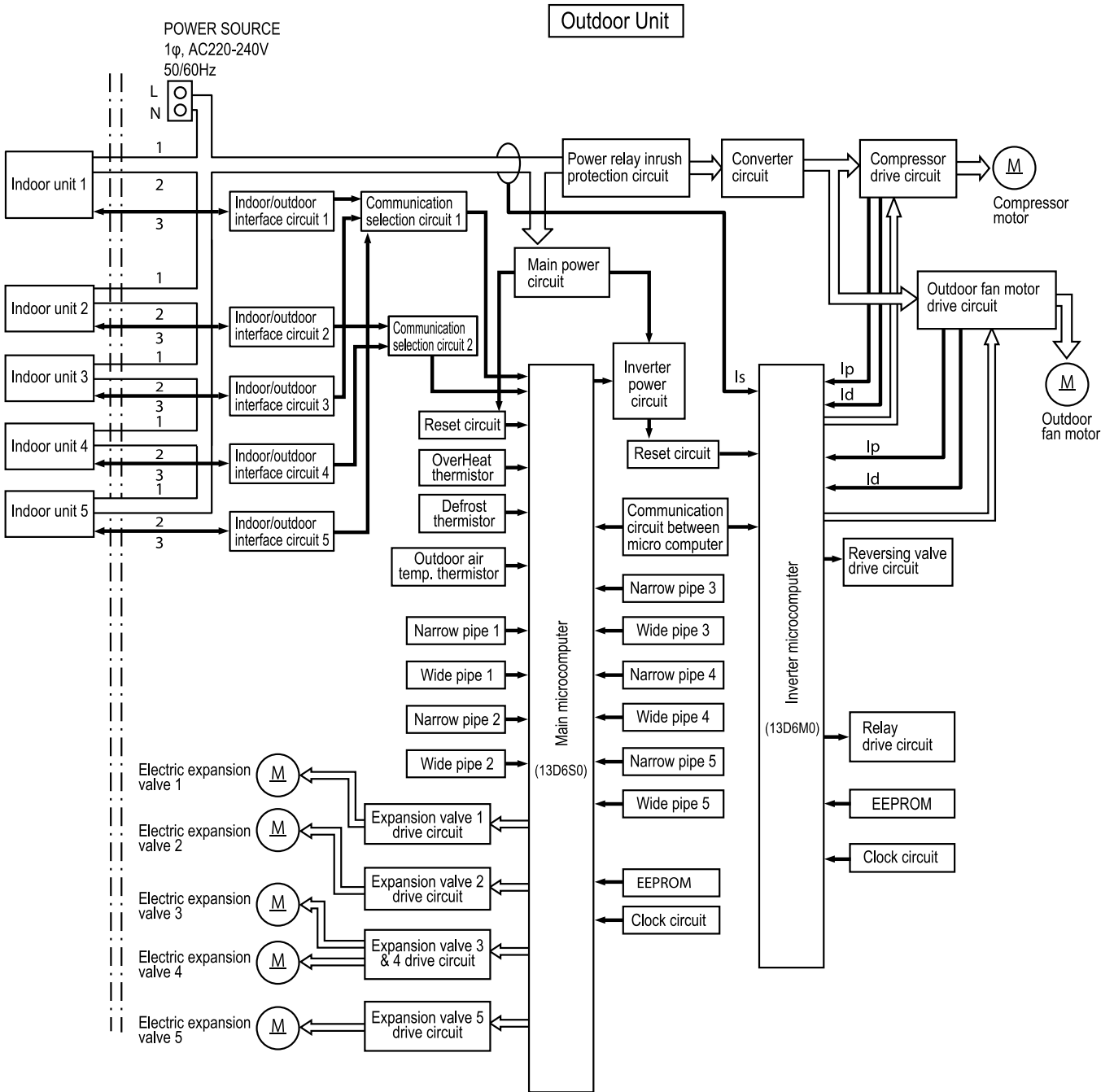

PRINTED WIRING BOARD LOCATION DIAGRAM

■ RAM-90NP5B

Main board [component side]

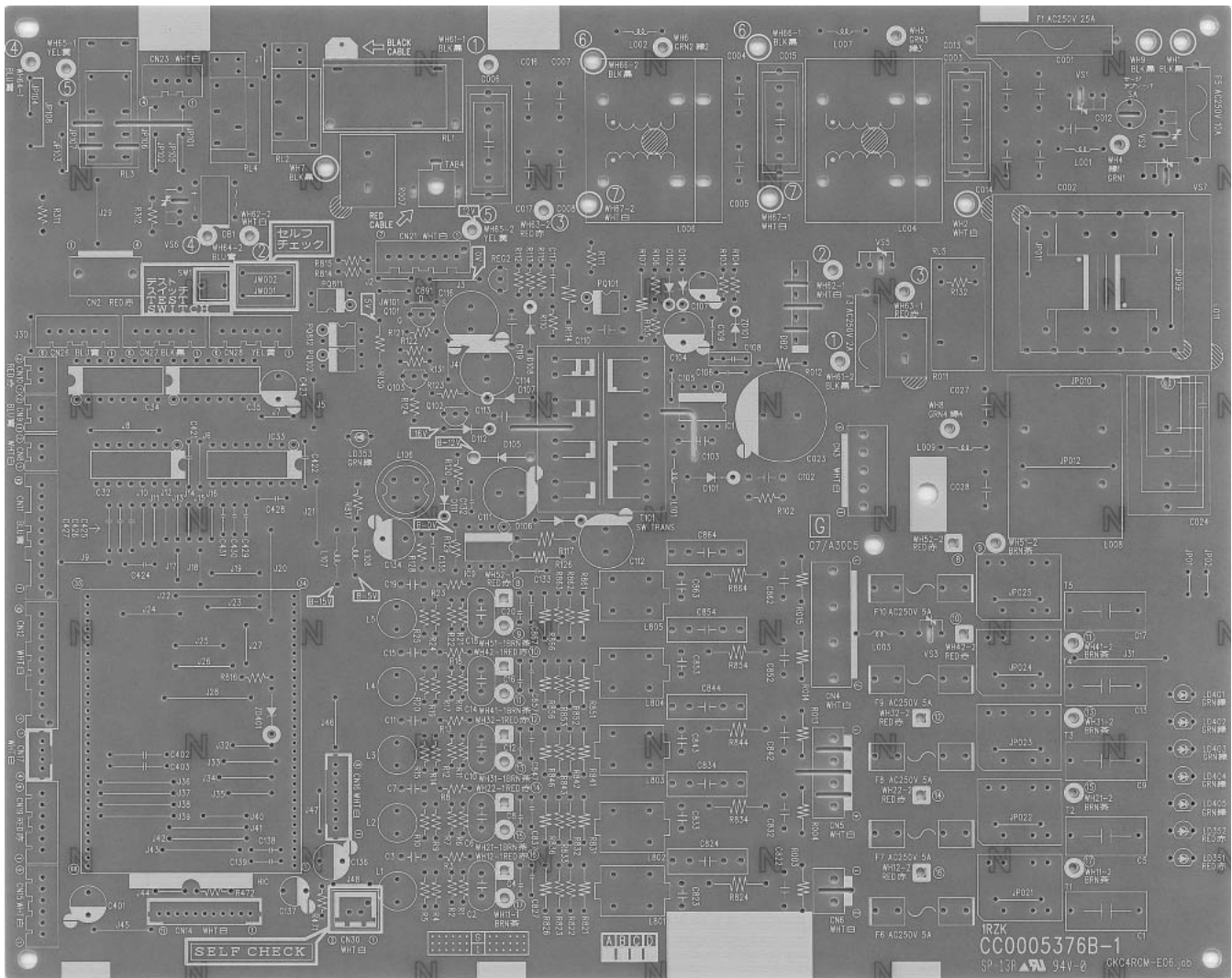

Main board [solder side]

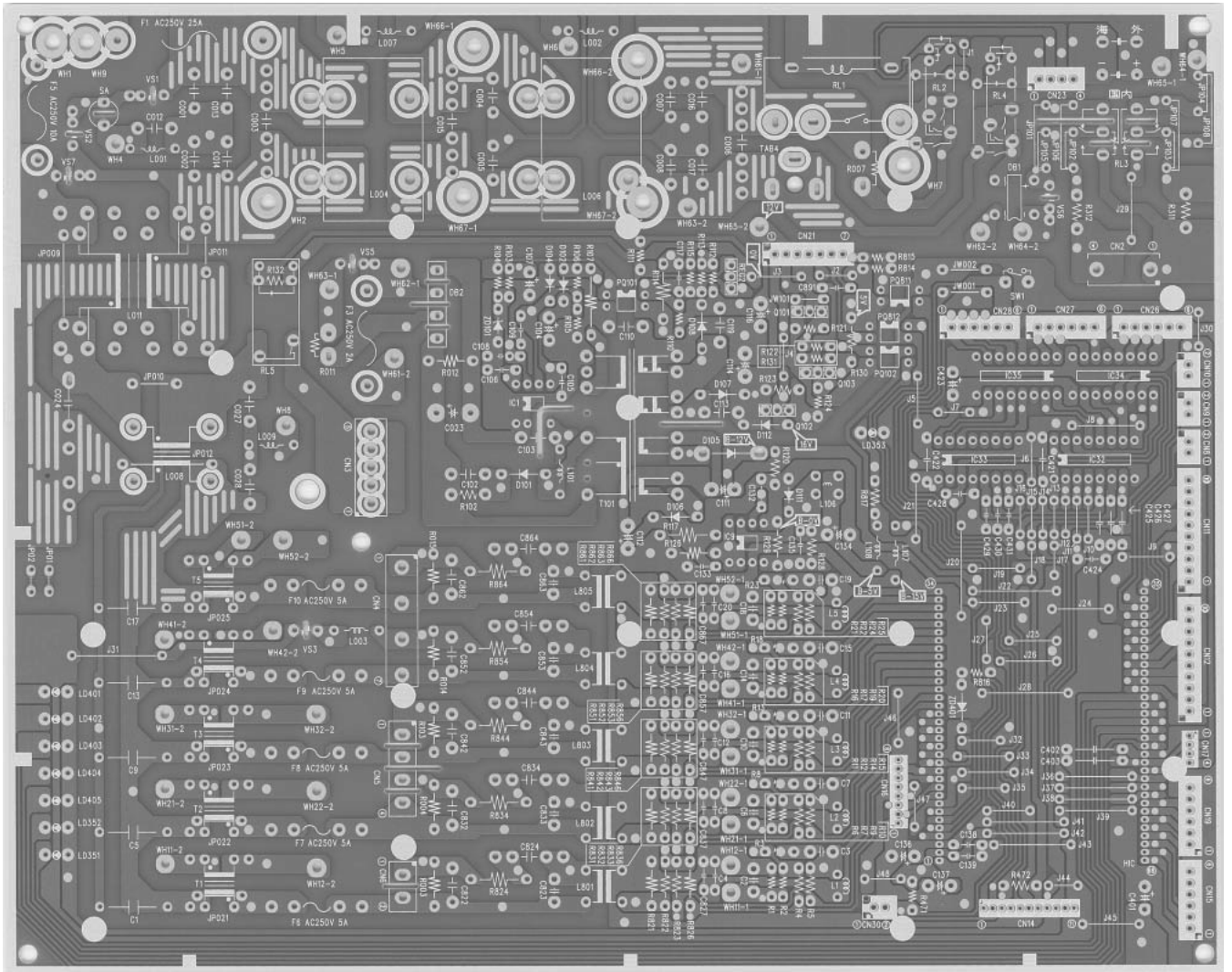

Inverter board [component side]

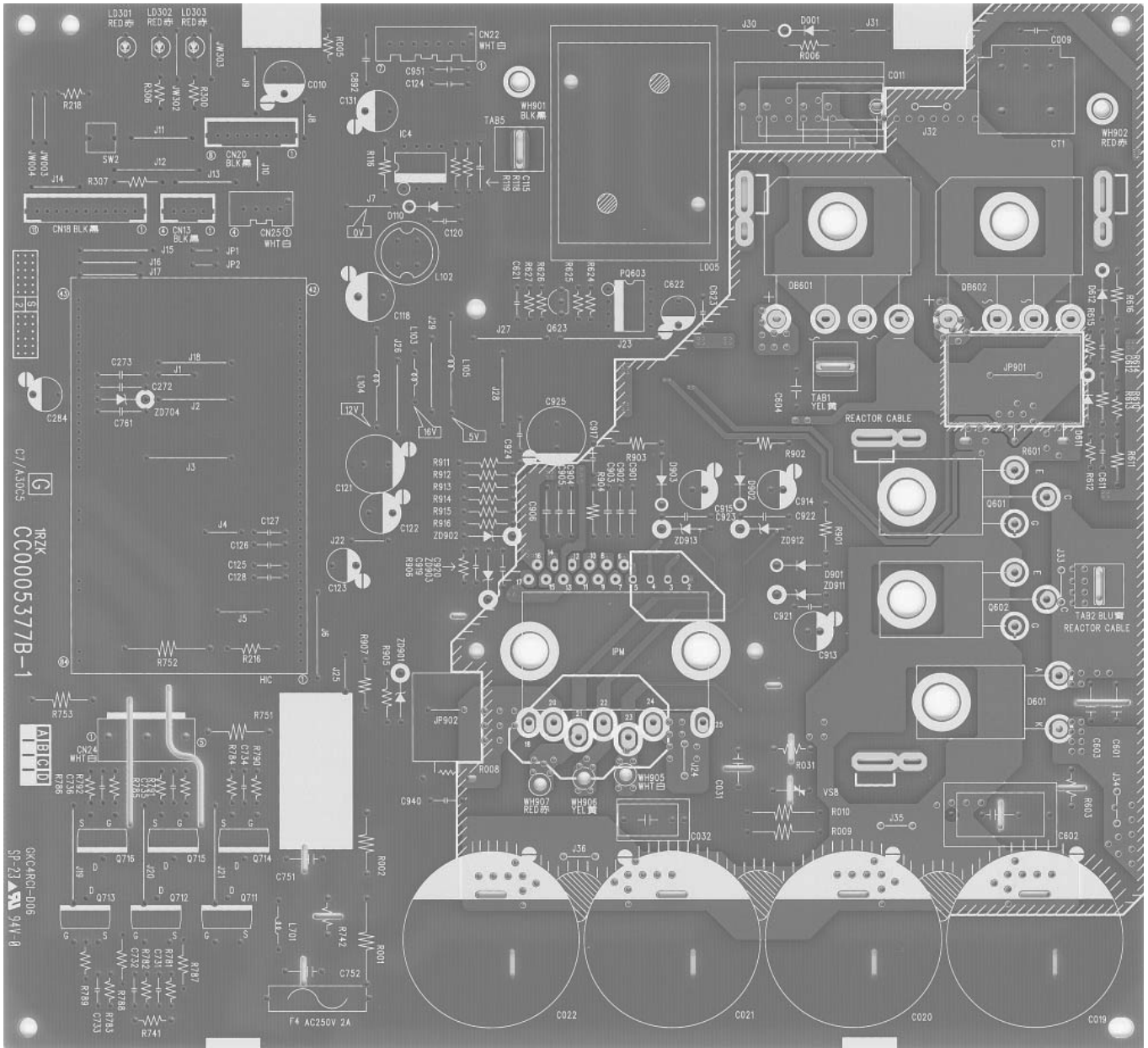

Inverter board [solder side]

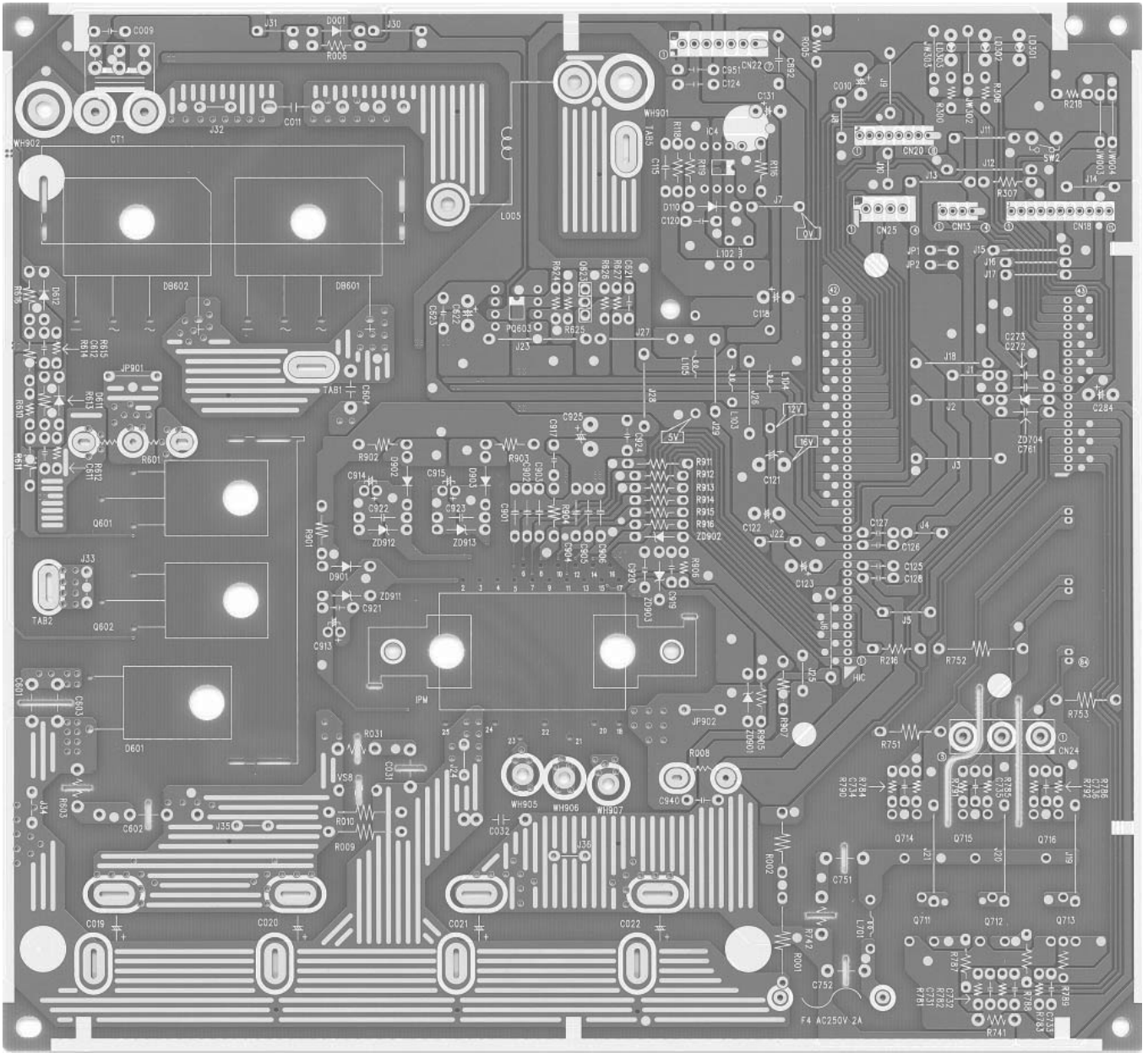

■ RAM-90NP5B

[Main board (HIC2)] top side

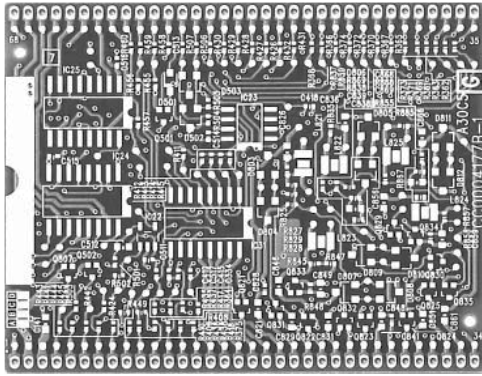

[Main board (HIC2)] bottom side

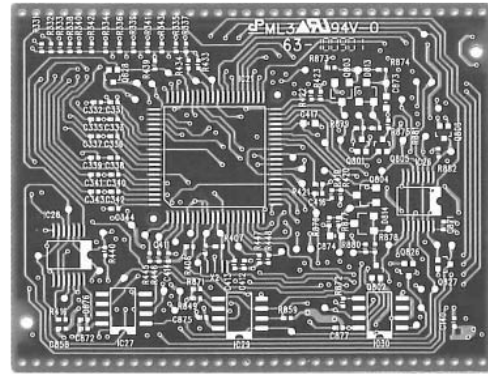

[Inverter board (HIC1)] top side

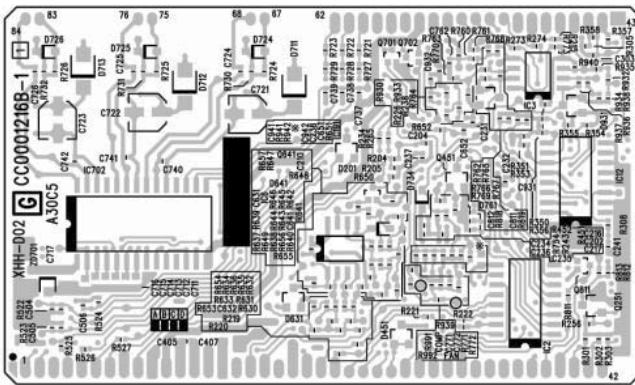

[Inverter board (HIC1)] bottom side

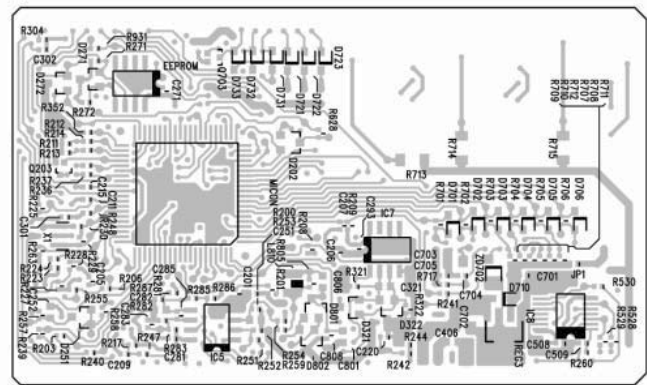

BASIC MODE

Operation mode		Fan	Cooling	Dehumidifying	Heating	Auto
Basic operation of start / stop switch						
Timer functions	Off-timer					
	On-timer					
Fan speed mode (indoor fan)	Auto	Changes from "Hi" to "Med" or "Lo" depending on room temperature.		Set to "Ultra-Lo", "Lo", "Med", "Hi", "Ultra-Hi" or "stop" depending on the room temperature, time and heat exchange temperature. Set to "stop" if the room temperature is 18°C in the "Ultra-Lo" mode other than during preheating (cooling is recovered at 18.33°C). When the compressor is running at maximum speed during hot dash or when recovered from defrosting.		<p>Operation mode</p> <ul style="list-style-type: none"> Judgment based on the room temperature and external temperature: <ul style="list-style-type: none"> Cooling: external temperature $\geq 25^{\circ}\text{C}$, or $21^{\circ}\text{C} \leq$ external temperature $< 25^{\circ}\text{C}$ and room temperature $> 27^{\circ}\text{C}$ Heating: external temperature $< 18^{\circ}\text{C}$, or $18^{\circ}\text{C} \leq$ external temperature $< 21^{\circ}\text{C}$ and room temperature $\leq 23^{\circ}\text{C}$ Dehumidifying: $21^{\circ}\text{C} \leq$ external temperature $< 25^{\circ}\text{C}$ and room temperature $\leq 27^{\circ}\text{C}$, or $18^{\circ}\text{C} \leq$ external temperature $< 21^{\circ}\text{C}$ and room temperature $> 23^{\circ}\text{C}$ Set to the mode of the indoor unit that has previously been operating. <ul style="list-style-type: none"> If, when one indoor unit is heating, the other unit is set to auto, the other unit will also enter the heating operation. If, when one indoor unit is cooling or dehumidifying, the other unit is set to auto, the other unit will enter the cooling or dehumidifying operation. <p>Set room temperature</p> <ul style="list-style-type: none"> All the following temperatures can be compensated for $\pm 3^{\circ}\text{C}$ using the remote control: (EXCEPT wired remote model) <ul style="list-style-type: none"> Cooling: 27°C Heating: 23°C Dehumidifying: Current room temperature (upper limit: 27°C, lower limit: 23°C) * Operates at a target of set temperature minus 2°C.
	Hi	Operates at "Hi" regardless of the room temperature.	Set to "Ultra-Hi" when the compressor runs at maximum speed, and to "Hi" in other modes.	Set to "Ultra-Lo", "Lo", "Med", "Hi", "Ultra-Hi" or "Stop" depending on the room temperature and time. Set to "Stop" if the room temperature is 18°C in the "Ultra-Lo" mode other than during preheating (cooling is recovered at 18.33°C). Set to "Ultra-Hi" when the compressor is running at maximum speed during hot dash or when recovered from defrosting.		
	Med	Operates at "Med" regardless of the room temperature.	Same as at left.	Set to "Ultra-Lo", "Lo", "Med" or "Stop" depending on the room temperature and time. Set to "Stop" if the room temperature is 18°C in the "Ultra-Lo" mode other than during preheating (cooling is recovered at 18.33°C).		
	Lo	Operates at "Lo" regardless of the room temperature.	Same as at left.	Set to "Lo" in modes other than when the compressor stops.	Set to "Ultra-Lo", "Lo", or "Stop" depending on the room temperature and time. Set to "Stop" if the room temperature is 18°C in the "Ultra-Lo" mode other than during preheating (cooling is recovered at 18.33°C). The fan speed is controlled by the heat exchanger temperature; the overload control is executed as in the following diagram:	
Basic operation of temperature controller	Performs only fan operation at the set speed regardless of the room temperature.	See page 53.	See page 95.	See page 99.		
Sleep operation (with sleep button ON)	Enters sleep operation after set as on the left. Action during sleep operation silent (sleep) operation	·Same as at left. ·See page 55.	·Same as at left. ·See page 97.	·Same as at left. ·See page 99.	·Same as at left. ·Performs the sleep operation of each operation mode.	

Combination of operations:

When operation mode is selected:

- You cannot operate the indoor units in the following combinations.
- The indoor unit which is switched on first continues to operate, but other indoor units which is switched on later, does not operate while the lamp lights.

One unit	Other unit
Heating	Cooling
	Dehumidifying
	Circulating (fan)

During automatic operation:

- When heating operation is automatically selected for the first indoor unit, the next indoor unit will then start to heat. Also, if cooling or dehumidifying is automatically selected for the first indoor unit, the next indoor unit will also start to cool or dehumidify.

Notes:

- Refer to the PWRITE-ZU data for the constants expressed by capital alphabet letters in the drawing.
- The speed set of rotation for the fan motor in each operation mode are as shown in Table 1.
- The set room temperatures in the diagram include the shift values in Table 2.

MODEL		RAM-90NP5B
PROM NO.	LABEL NAME	REQUIRED VALUE OF UNIT SIDE
OAE	OH_ON_C	118.2 °C
OAF	OH_OFF_C	104.7 °C
OB6	OH_ON_W	100.0 °C
OB7	OH_OFF_W	86.5 °C
108	PSTARTC1_d	250
109	PSTARTC1K_d	300
10A	PSTARTC2_d	180
10B	PSTARTC2K_d	300
10C	PSTARTC3_d	180
10D	PSTARTC3K_d	300
10E	PSTARTC4_d	180
10F	PSTARTC4K_d	300
110	PSTARTC5_d	180
111	PSTARTC5K_d	300
112	PSTARTH1_d	200
113	PSTARTH1S_d	250
114	PSTARTH2_d	150
115	PSTARTH2S_d	200
116	PSTARTH3_d	150
117	PSTARTH3S_d	200
118	PSTARTH4_d	150
119	PSTARTH4S_d	200
11A	PSTARTH5_d	160
11B	PSTARTH5S_d	200
124	DFCTPS_d	150
126	DFSPPS_d	10
127	DFPSMX_d	400
12B	PCLOSH_d	86
238	STAROTP_C	25.0 °C
239	SDRCT1_C1	2500 min ⁻¹
23A	TSKTM1_C1	60 sec
2B	SDRCT1_C2	2500 min ⁻¹
23C	TSKTM1_C2	60 sec
23D	STAROTP_W	4.8 °C
23E	SDRCT1_W1	2500 min ⁻¹
23F	TSKTM1_W1	60 sec
240	SDRCT1_W2	2500 min ⁻¹
241	TSKTM1_W2	60 sec
242	SDSTEP	500 min ⁻¹
243	TSKSPT	30 sec
24E	CMAX1	5300 min ⁻¹
24F	CMAX2	7000 min ⁻¹
251	CMAX3	7000 min ⁻¹
253	CMAX4	7000 min ⁻¹
255	CMAX5	7000 min ⁻¹
25B	WMAX1	6500 min ⁻¹
25C	WMAX2	7000 min ⁻¹
25F	WMAX3	7000 min ⁻¹
264	WMAX4	7000 min ⁻¹
26B	WMAX5	7000 min ⁻¹
3C2	TDF414	90 sec
3C3	TDF415	90 sec
3C4	DFMXTM	12 min
3C5	SDRCT2	2000 min ⁻¹
3C6	TSKTM2	70 sec
3C7	DFSTEP	500 min ⁻¹
3C8	TDFSPT	60 sec
3C9	DEFMAX	400 min ⁻¹
3CC	DFSTMB	50 min
3CD	DFSTMB2	60 min

Basic Cooling Operation

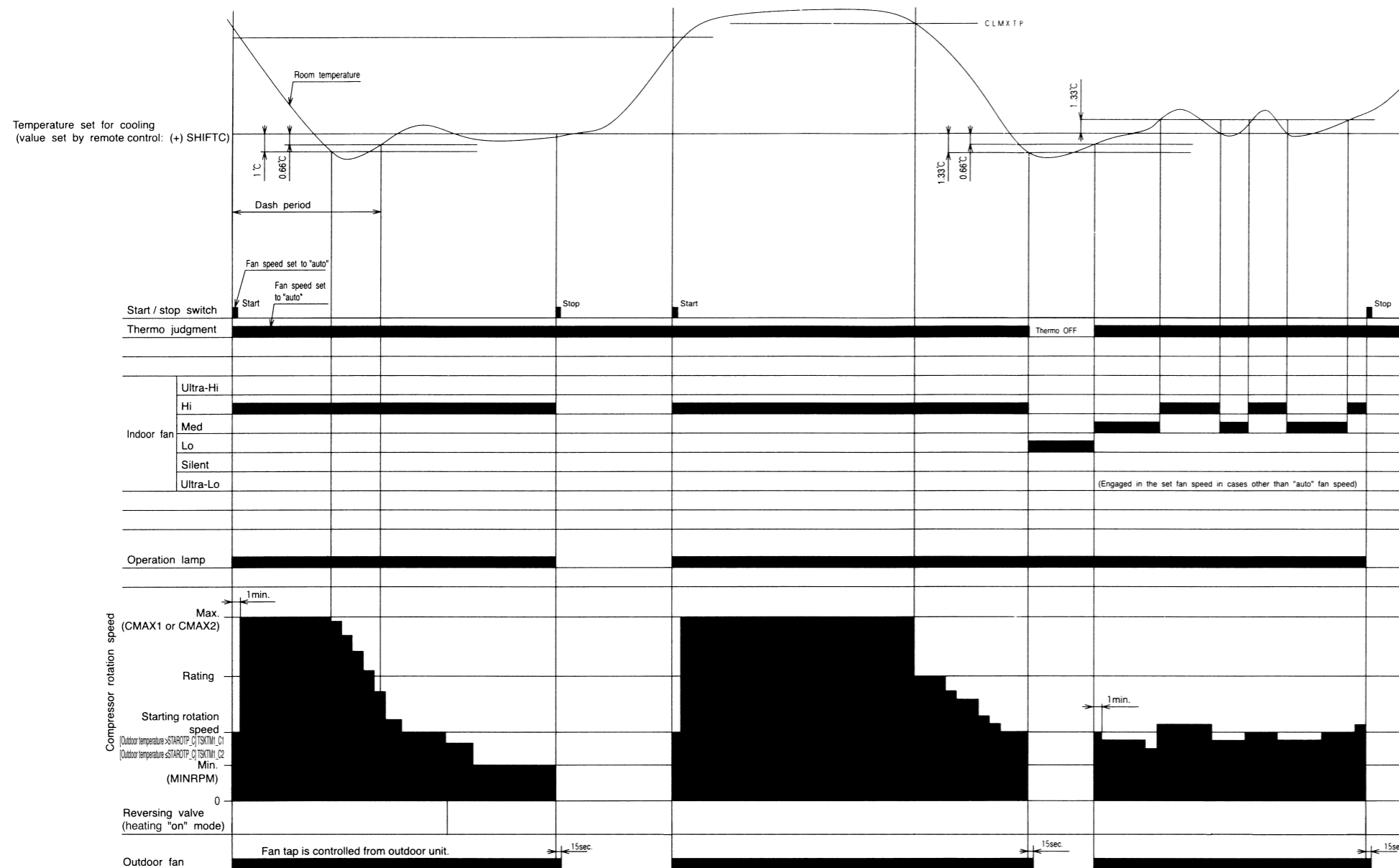

Notes:

- (1) Cool dash is started when the operation is started at fan speed "AUTO" or "HI" or when the fan speed is changed to "AUTO" or "HI" during cooling operation, and when the compressor speed (P item) reaches (CMAX1 to CMAX2) or higher.
- (2) The maximum compressor speed period during cool dash is finished.
 - 1 When 25 minutes have elapsed after cool dash was started.
 - 2 When the room temperature reaches the cooling set temperature -1°C (including cooling shift) and then becomes lower than the preset temperature by 0.66°C after the steady speed period
 - 3 When thermo is OFF.
 (If cool dash finished in the above 1, the compressor does not go through the steady speed period but it starts fuzzy control.)
- (3) The thermo OFF temperature during cool dash is cooling set temperature (including cooling shift) -3°C. After thermo OFF, cool dash is finished and fuzzy control starts.
- (4) The compressor minimum ON time and minimum OFF time is 3 minutes.
- (5) The time limit for which the maximum compressor speed (CMAX1 or CMAX2) during normal cooling can be maintained is less than 60 minutes when the room temperature is less than CLMXTP: it is not provided when the room temperature is CLMXTP or more.
- (6) Compressor speed is determined by instruction sent from indoor unit and corrected by outdoor unit according to such factors as capacity, fan speed, number of units being operated, outdoor temperature, etc.
- (7) If another indoor unit is doing heating operation, cooling operation cannot be done.

Cooling Sleep Operation

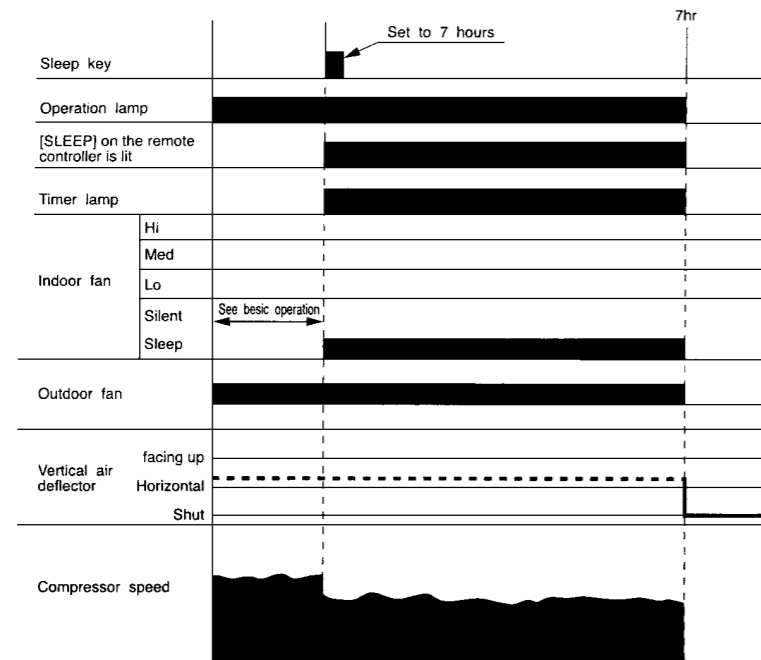

Notes:

- (1) The sleep operation starts when the sleep key is pressed.
- (2) When the sleep key is set, the indoor fan is set to "sleep silent" (FCSOY_M or AFCOY).
- (3) The indoor fan speed does not change even when the fan speed mode is changed.
- (4) If the set time is changed during sleep operation, all data including set temperature, time, etc. is cleared and restarted.
- (5) If sleep operation is canceled by the cancel key or sleep key, all data is cleared.
- (6) If the position of air deflector is being operated using remote control, the operation will be performed at any desired position of air deflector.

Note:

1. Refer to the PWRITE-ZU data for the constants expressed by capital alphabet letters in the drawing.

Cooling Defrost

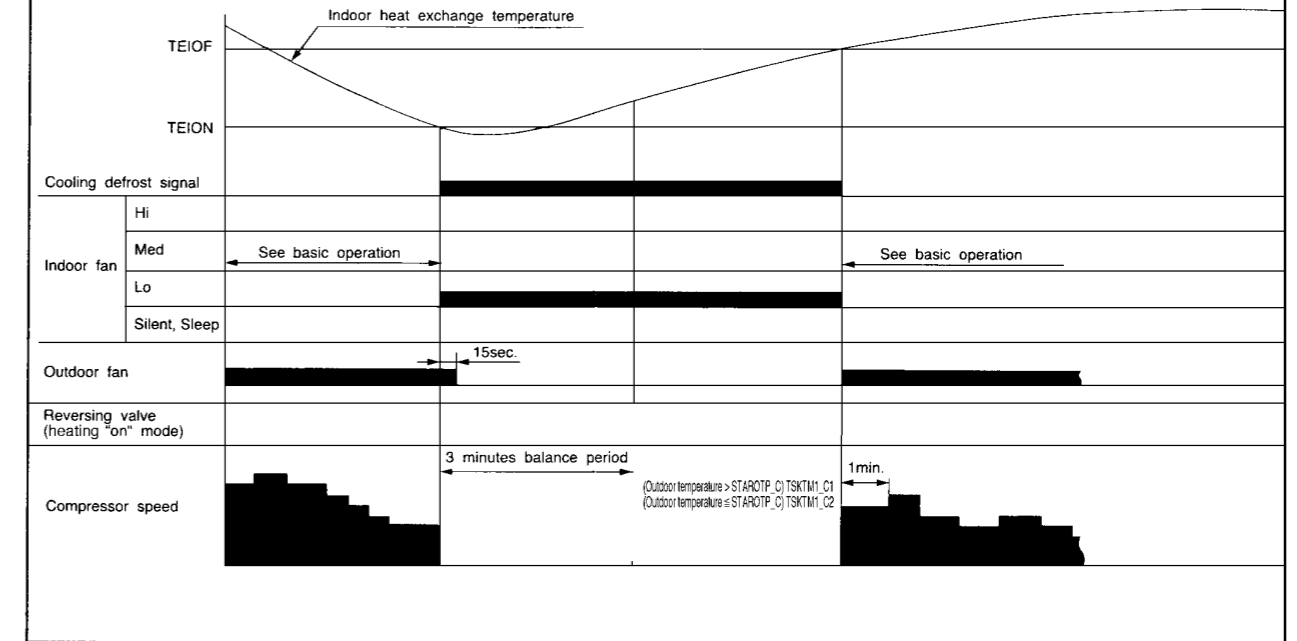

Dehumidifying

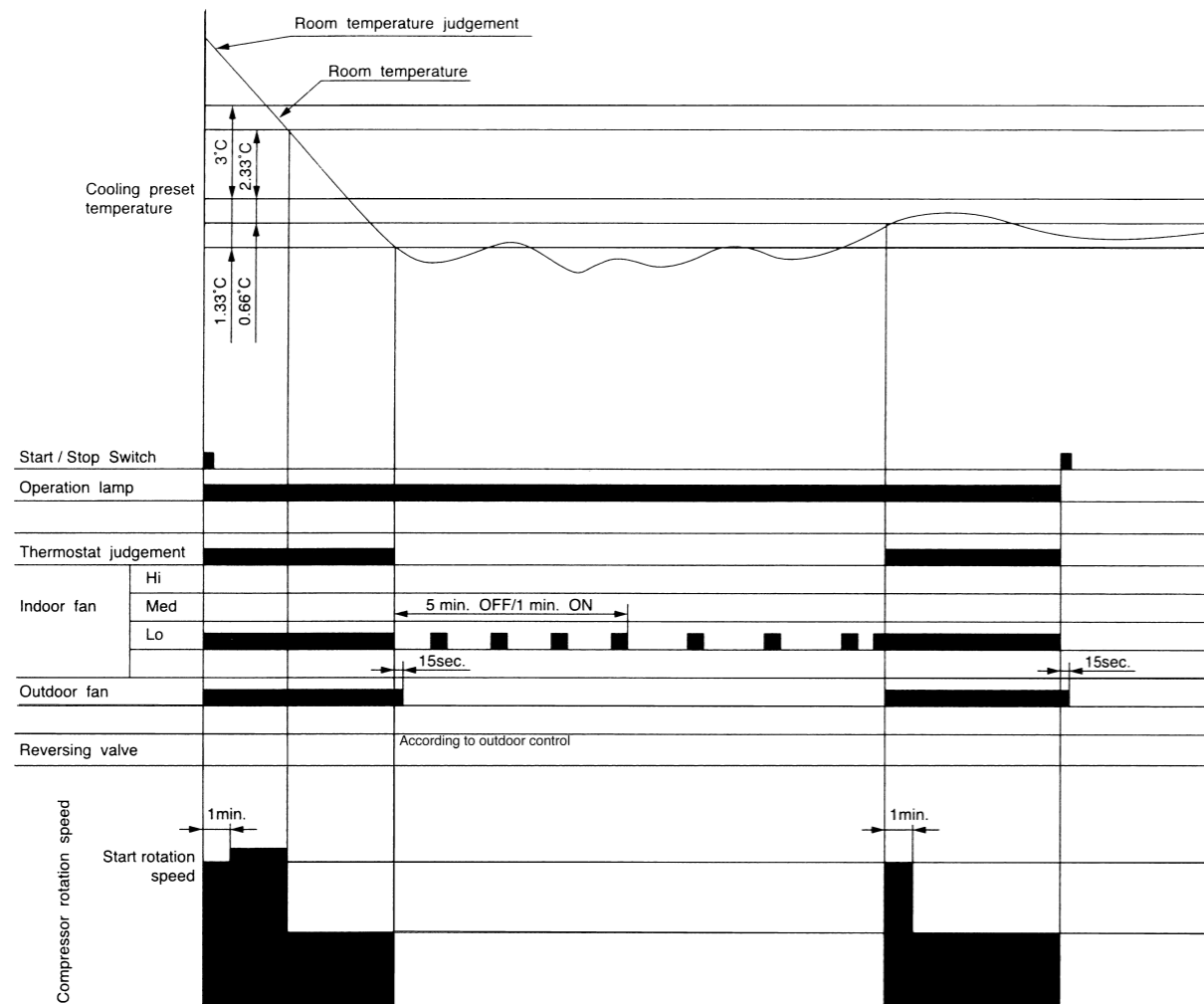

Notes:

- (1) The indoor fan is operated in the "Lo" mode, OFF for 5 minutes and ON for 1 minute, repeatedly according to the humidity judgement when the thermostat is turned OFF.
- (2) The compressor is operated forcedly for 3 minutes after operation is started.
- (3) The minimum ON time and OFF time of the compressor are 3 minutes.
- (4) At the start of operation, the thermostat will be off when room temperature \leq setting temperature -1.33°C ; the thermostat will be on when room temperature \geq setting temperature -0.66°C .
- (5) The following procedure is performed to prevent excessive cooling during operation other than start. However, this procedure applies only when the thermostat is intermittent:
 - Whether THERMO ON is to continue or not depends on the thermal condition when the 3-minute forced operation ceases.
 - ① "THERMO ON continues" when room temperature \geq setting temperature $+1^{\circ}\text{C}$: (The THERMO operation value is usually the same as that at "start of operation")
 - ② "Forced THERMO OFF" when room temperature $<$ setting temperature $+1^{\circ}\text{C}$: (The same THERMO operation value as that at "start of operation" is usually used for recovery)
 Therefore, if the air-conditioner is stabilized under this thermal condition, it will enter intermittent operation, which is "3-minute operation/3-minute stop".
- (6) Compressor speed is determined by instruction sent from indoor unit and corrected by outdoor unit according to such factors as capacity, fan speed, number of units being operated, outdoor temperature, etc.

Dehumidifying Sleep Operation

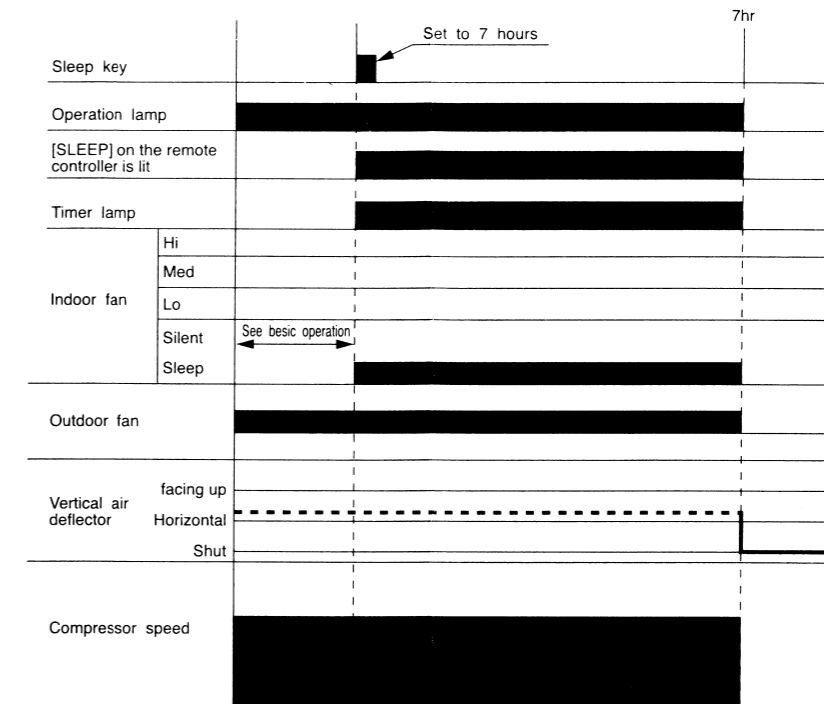

Notes:

- (1) The sleep operation starts when the sleep key is pressed.
- (2) When the sleep key is set, the indoor fan is set to "sleep silent" (FDOY_M or AFDOY).
- (3) The indoor fan speed does not change even when the fan speed mode is changed.
- (4) If the set time is changed during sleep operation, all data including set temperature, time, etc. is cleared and restarted.
- (5) If sleep operation is canceled by the cancel key or sleep key, all data is cleared.
- (6) If the position of air deflector is being operated using remote control, the operation will be performed at any desired position of air deflector.

Heating Basic Operation

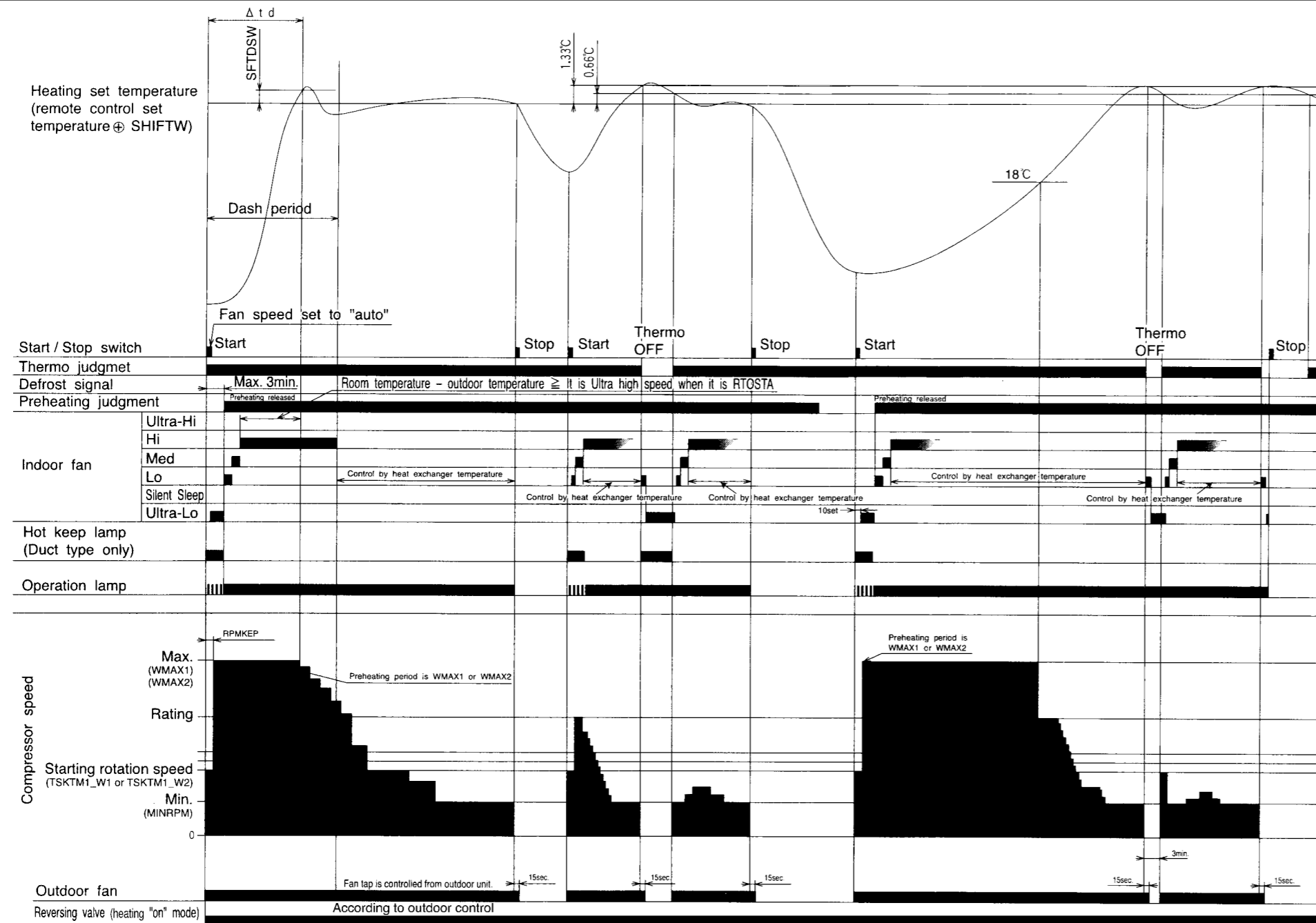

Notes:

- (1) Hot Dash is started when the operation is started at fan speed "AUTO" or "HI" or when the fan speed is changed to "AUTO" or "HI" during heating operation, and when the compressor speed (P item) reaches (WMAX1 or WMAX2) or higher with the room temperature at 8°C or less and outdoor temperature at 10°C or less.
- (2) The maximum compressor speed period during hot dash is finished
 - ① when the room temperature reaches the heating set temperature (including heating shift) plus SFTDSW or
 - ② when the thermo is off.
- (3) The thermo OFF temperature during hot dash is heating set temperature (including heating shift) plus 3°C. After thermo OFF, hot dash finishes, and PI control starts.
- (4) The compressor minimum ON time and minimum OFF time is 3 minutes.
- (5) The time limit for which the maximum compressor speed (WMAX1 or WMAX2) during normal heating (except for hot dash) can be maintained is less than 120 minutes when the room temperature is 18°C or more; it is not provided when the room temperature is less than 18°C and outdoor temperature is less than 4°C.
- (6) The operation indicator will blink every second during initial cycle operation, preheating, defrosting (including balance time after defrost is finished), or auto fresh defrosting. However, with duct type models, operation indicator does not blink, but Hot Keep indicator will light.
- (7) For preheating judgment, preheating starts if the heat exchange temperature is lower than YNEOFC and is cancelled if the heat exchange temperature is YNEOF plus 0.33°C or higher at the start of operation using the START / STOP button.
- (8) If the room temperature falls to less than 18°C in the "Ultra-Lo" mode, the indoor fan stops. When the room temperature is 18°C+0.33°C or more, the ultra-Lo operation restarts. However, the ultra-Lo operation during preheating or preheating after defrosting does not stop if the room temperature is less than 18°C.
- (9) Compressor speed is determined by instruction sent from indoor unit and corrected by outdoor unit according to such factors as capacity, fan speed, number of units being operated, outdoor temperature, etc.
- (10) If another indoor unit is doing cooling operation, dehumidifying operation or fan operation, heating operation cannot be done.

Heating Sleep Operation

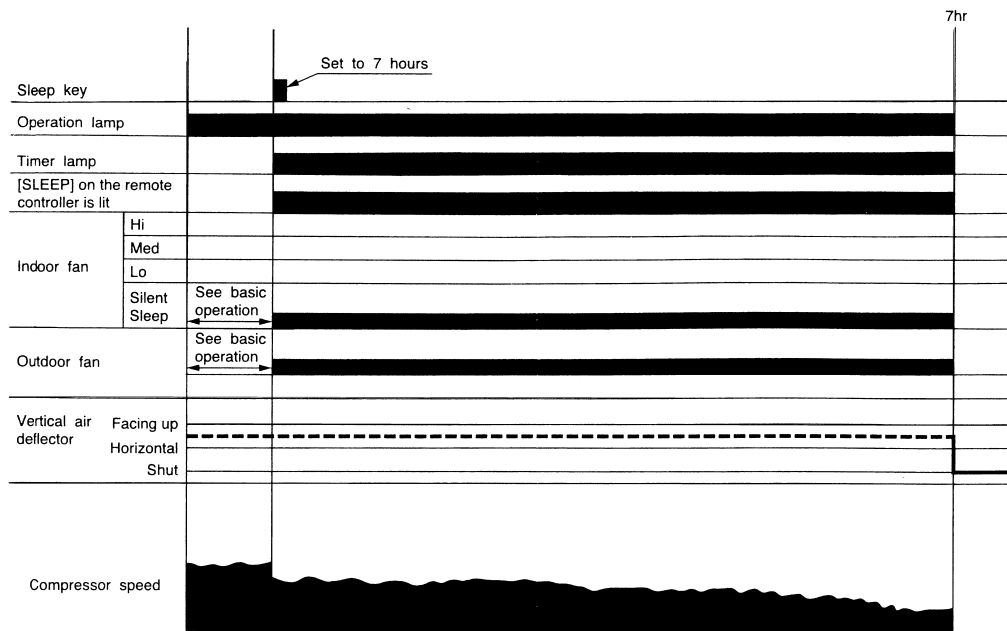

Notes:

- (1) The sleep operation starts when the sleep key is pressed.
- (2) When the sleep key is set, the indoor fan is set to "Sleep Silent" (FWSOY_M or AFWSOY).
- (3) The indoor fan speed does not change even when the fan speed mode is changed.
- (4) When defrosting is to be set during sleep operation, defrosting is engaged and sleep operation is restored after defrosting.
- (5) If the set time is changed during sleep operation, all data including set temperature, time, etc. is cleared and restarted.
- (6) If sleep operation is canceled by the cancel key or sleep key all data is cleared.
- (7) If the position of air deflector is being operated using remote control, the operation will be performed at any desired position of air deflector.

NOTE:

1. Refer to the PWRITE-ZU data for the constats expressed by capital alphabet letters in the drawing.

MODEL RAM-90NP5B

◇ Expansion valves

- The expansion valves are initialized when power is supplied. The valve for unit 1 is fully closed (–520 pulses), and then that for unit 2 is fully opened (480 pulses). The valve for unit 2 is fully closed (–520 pulses), and then that for unit 3 is fully opened (480 pulses). The valve for unit 3 is fully closed (–520 pulses), and then that for unit 4 is fully opened (480 pulses). The valve for unit 4 is fully closed (–520 pulses), and then that for unit 5 is fully opened (480 pulses). When the valve for unit 1, 2, 3, 4, 5 is fully closed (0 pulse), start-up is possible.
- The start openings are held during the steady speed period when the compressor is started. After the steady speed period is finished, the TD control is entered. The start openings are set to PSTARTH when the outdoor temperature at start 40°C or more, and to PSTART when it is less than 40°C. PSTART C3 is used for 3 rooms and 4 rooms operation.

◇ Compressor rotation speed

- When the compressor is started, the SDRCT1 speed / TSKTM1 second is held. (Steady speed period) After the steady speed period is finished, the speed increases at the rate of SDSTEP speed / TSKSPT second until the target speed is reached.

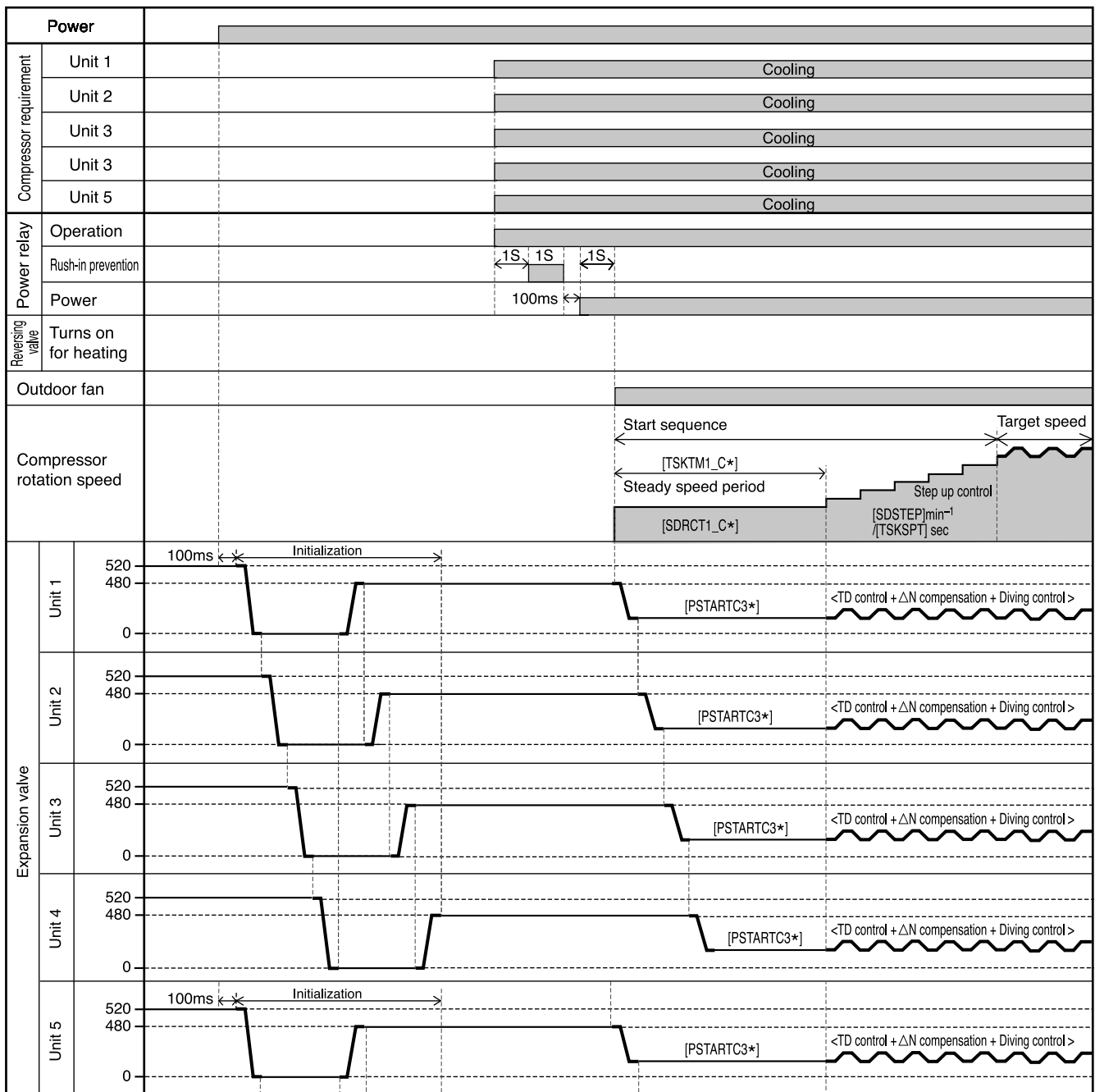

※ TSKTM1, SDRCT1, SDSTEP, TSKSPT, CMAX2, PSTART and PSTARTH are EEPROM data.

DEFROST

• Reversing valve defrost system is employed: it consists of balancing period → reversing cycle period → balancing period.

(1) Defrost start condition

• When all the following conditions are established defrost is executed:

- ① Normal operation
- ② Heat exchange temperature is within defrost range specified by outdoor temperature and heat exchange temperature. (Defrost signal occurred).
- ③ Defrost inhibit period linked to outdoor temperature has passed.

(2) Defrost release condition

• If any one of the following conditions is established, defrost is released:

- ① Heat exchange temperature returns (heat exchange temperature \geq DEFOFF).
- ② Defrost max time of 12 minutes has elapsed.

• Released by condition ① during balancing period: When remaining balancing period has elapsed, returned to initial condition (ASTUS=0).

• Released by condition ① or ② during reversing cycle period: [TDF415] Shifted to balancing period.

(3) Outputs during defrost

• Indoor defrost request: Transmitted to all units being operated in heating mode.

• Compressor : Balancing period for [TDF414] seconds → Starting of reversing cycle period by [SDRCT2] min^{-1} for [TSKTM2] seconds → Accelerating by [DFSTEP] min^{-1} /[TDFSPT] seconds in remaining reversing cycle period until defrost MAX speed [DEFMAX] is reached → Balancing period for [TDF415] seconds

• Electric expansion valve

Unit being stopped : [FULL CLOSE] 30 seconds after balancing period has passed → [FULL CLOSE] during reversing cycle period → [PCLOSH\$] 15 seconds before balancing period is finished

Unit being operated : [DFCTPS] 30 seconds before balancing period is finished → Synchronized with step-up of rotation speed of compressor, opened by [DFSPPS] pulses and reaches MAX opening degree [DEFSMX] when rotation speed of compressor reaches [DEFMAX].

RAM-90NP5B DEFROST TEMPERATURE

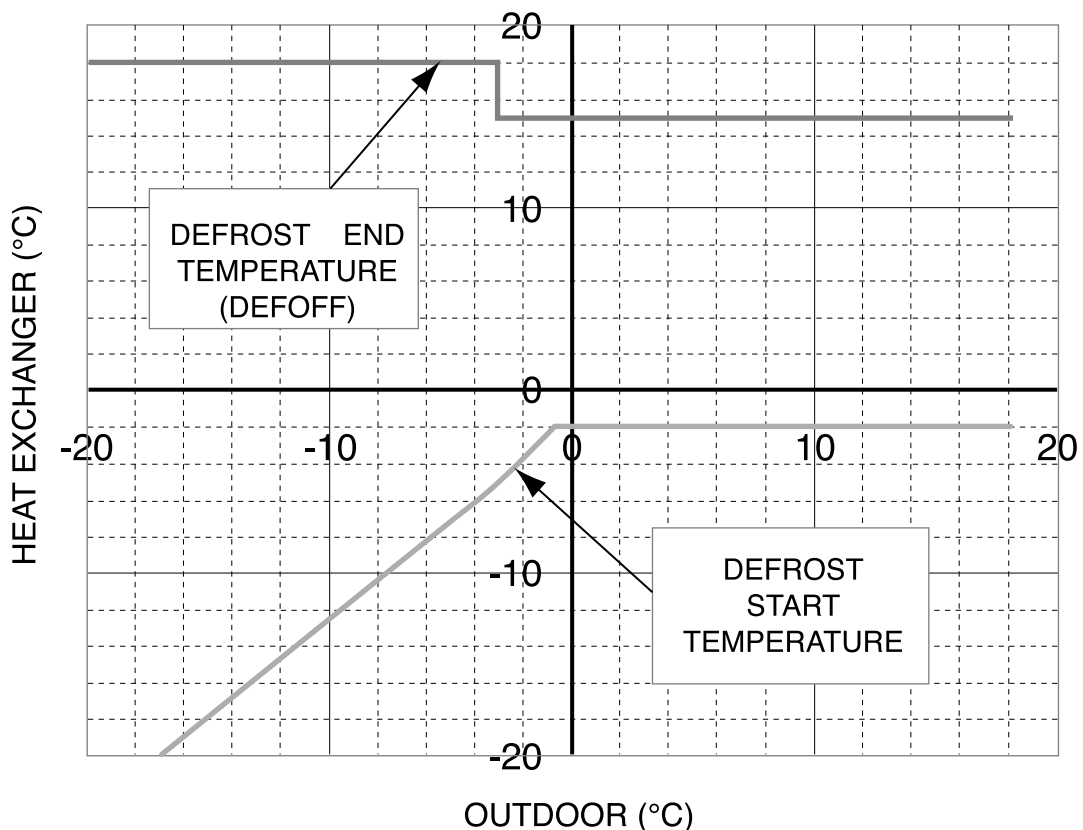

* above graph is showing the ideal value by micon program.

* guaranteed temperature range of this model is -15°C to $+23^{\circ}\text{C}$ at heating.

MODEL RAM-90NP5B

• Time chart when executing defrost (Unit 1 and Unit 2 operated, Unit 3, Unit 4 and Unit 5 stopped)

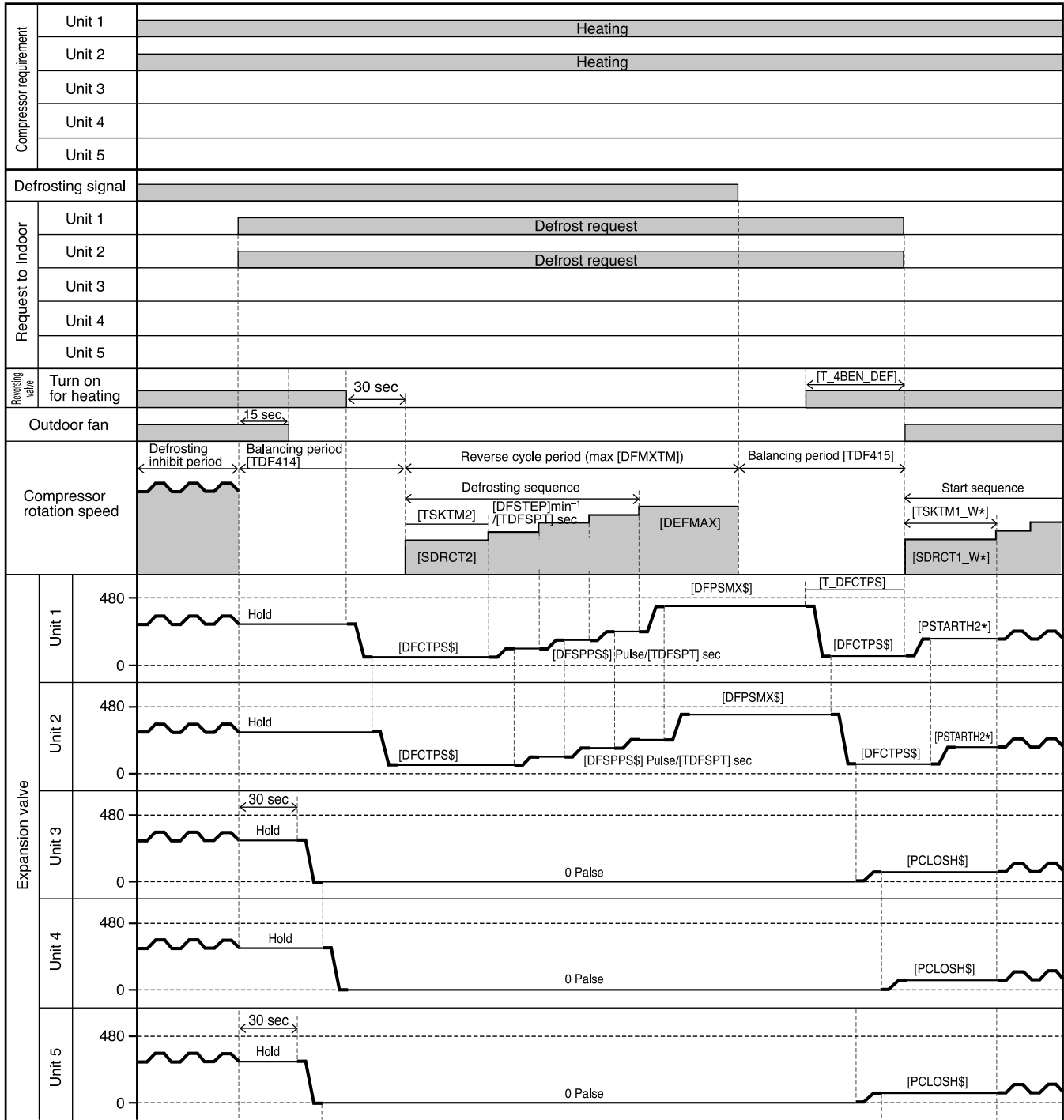

AUTO-FRESH DEFROST

- During heating operation is stopped, and when auto-fresh condition is established, defrost operation will be performed while operation is stopped.

Auto-fresh consists of balancing period at start of defrost for [TDF414] seconds → Reverse cycle period for MAX 12 minutes.

(1) Start conditions for auto-fresh

- When all the following conditions are established, auto-fresh is executed:
 - ① Defrost request signal is present.
 - ② All indoor units are stopped.
 - ③ 15 minutes of auto-fresh inhibit period has elapsed.
 - ④ Compressor is ON when operation is stopped.
 - ⑤ Compressor delay command is sent from indoor unit when operation is stopped.

(2) Release condition of auto-fresh

- If any one of following conditions is established, auto-fresh is released:
 - ① Heat exchange temperature returns (heat exchange temperature \geq DEFOFF)
 - ② 12 minutes of defrost MAX time has elapsed.
 - ③ Failure occurred.
 - ④ Either unit 1 or unit 2 or unit 3 or unit 4 started operation.
- ※ Released during start of balancing period : Stopped or started after remaining balancing period has elapsed.
- Released during reverse cycle period : Stopped or started after balancing for 3 minutes.

(3) Outputs during auto-fresh

[Indoor unit defrost request]: Transmitted only to unit to which auto-fresh is applied (indoor unit stopped last).

[Compressor]: Accelerated by $DFSTEP \text{ min}^{-1}/TDFSPT$ seconds and reaches defrost MAX speed [DEFMAX].

[Electric expansion valve]:

Unit auto-fresh not applied: FULL CLOSE when balancing for 30 seconds has elapsed at start of defrost.

Unit auto-fresh applied : Synchronized with step-up of rotation speed of compressor, opened by [DFSPSS] pulses and reaches MAX opening degree [DEFMAX] when rotation speed of compressor reaches [DEFMAX].

(4) Note

- Shifted to auto-fresh in defrost mode when operation is stopped.
- All indoor units must be stopped to fulfill condition for auto-fresh.
- If signal is delayed, auto-fresh condition will not be established.

MODEL RAM-90NP5B

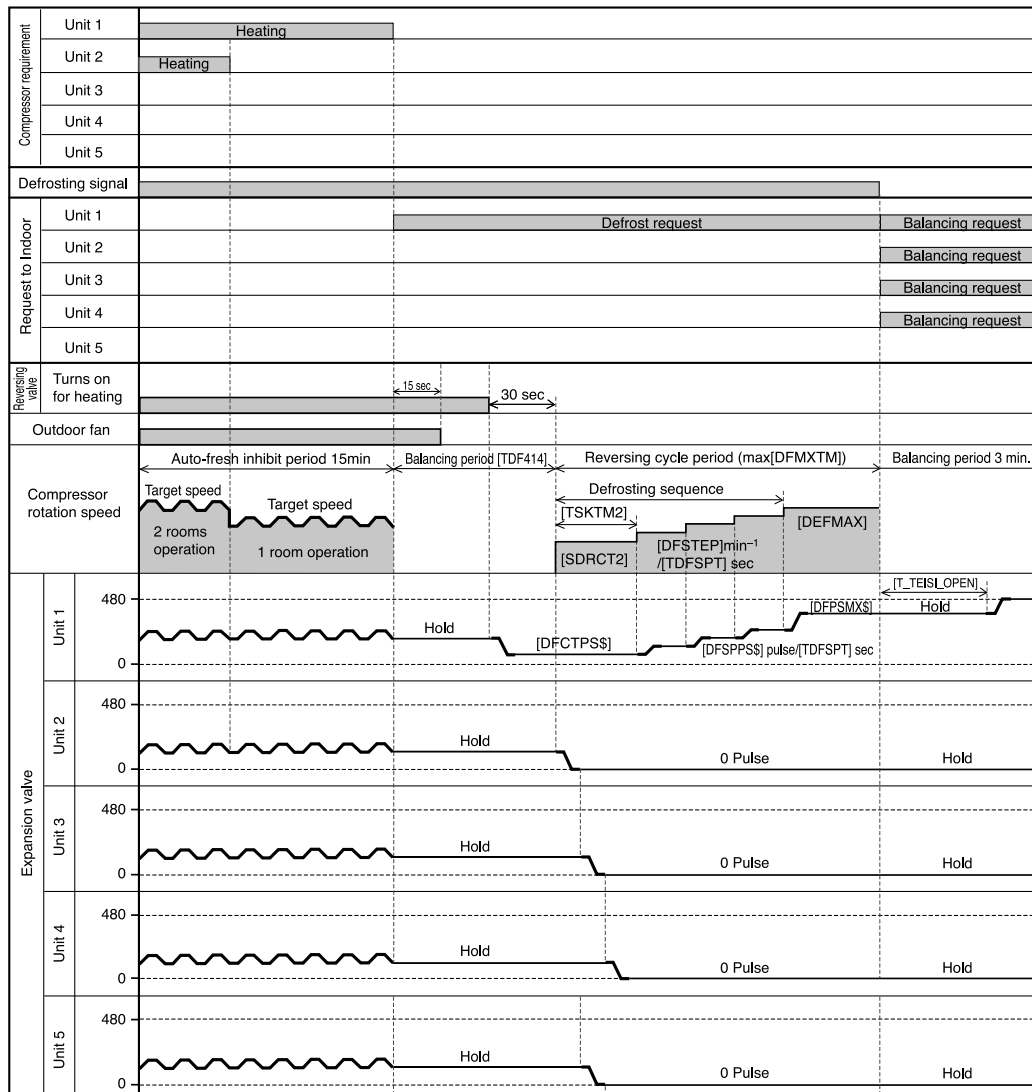

MODEL RAM-90NP5B

FORCED COOLING

- In order to accumulate refrigerant, units operate in cooling cycle. Execution condition and operation status are shown below.

[Execution condition]

- With neither indoor unit 1, 2, 3, 4 and 5 not operated, when service switch is turned ON, forced cooling will be performed.
- Always operation status of indoor units are monitored and forced cooling is inhibited when operation of any unit is detected.

[Operation status]

- Outdoor unit fan: Fixed in LO.
- Compressor rotation speed: Fixed in 3000min⁻¹.
- Expansion valve/reversing valve : Set in normal conditions.

[Note]

- During forced cooling, if failure occurs in outdoor unit, thermostat is turned off. However, it is not counted.
- Since rotation speed of compressor is fixed in 3000min⁻¹ during forced cooling, steady speed period of compressor at start is not performed.

- The following shows the operation state of forced cooling.

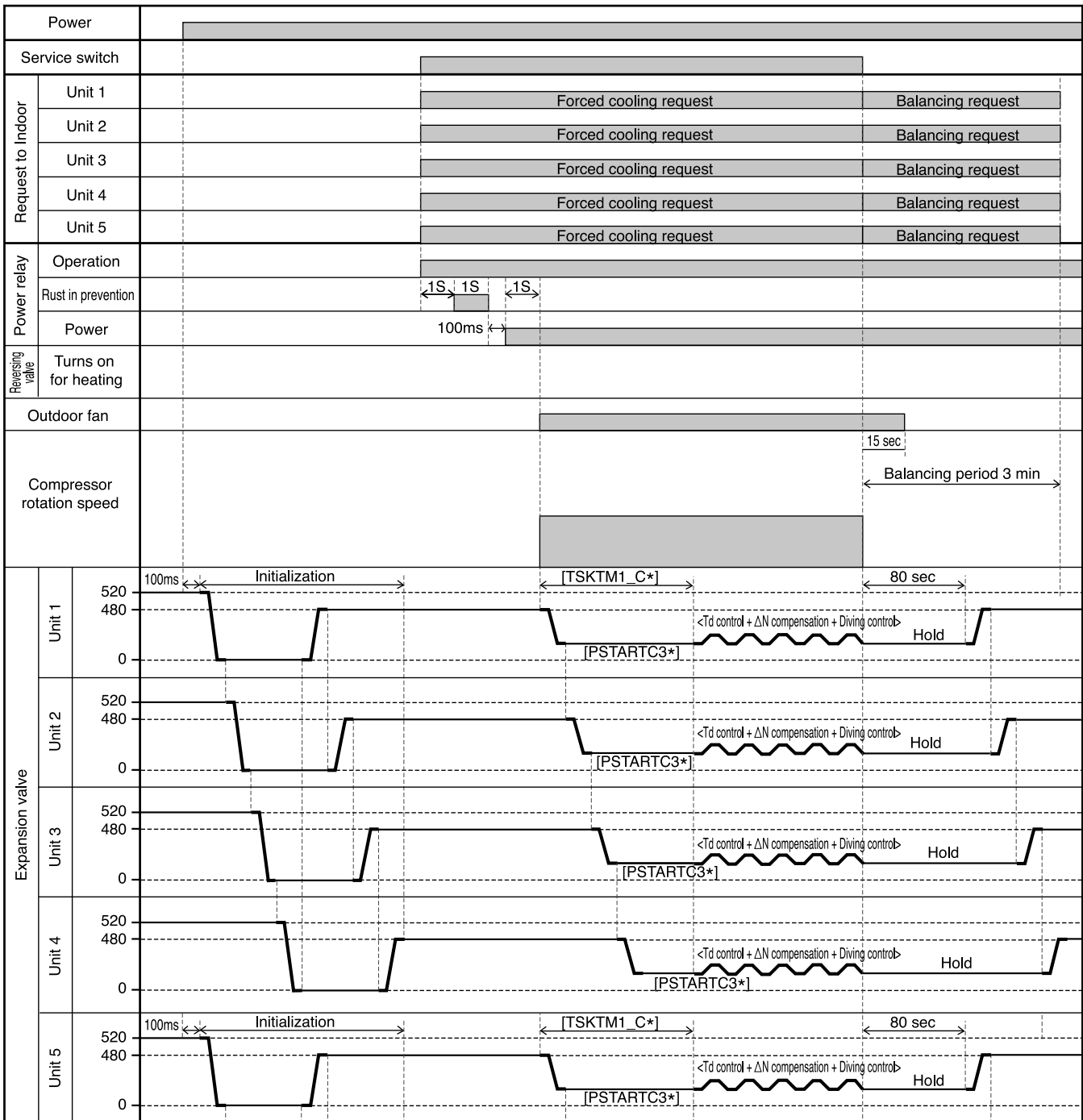

※ TSKTM1_C and PSTARTC2\$ are EEPROM data.

MODEL RAM-90NP5B

PROCESSING AT OVERHEAT THERMISTOR (OH) HIGH TEMPERATURE

- ◇ Restriction Start Conditions
 - If any expansion valve is operated at 480 pulses and the OH temperature > [NDOWN_ON], the compressor speed will be reduced at a rate of 100 min⁻¹/30 seconds.
 - This reduced rotation speed is based on the speed when the reduction started, and will be maintained until the reduction is finished. However, the reference speed will be exchanged only if the target speed is lower than the speed when the reduction started.
 - If [NDOWN_OFF] ≤ OH temperature ≤ [NDOWN_ON] and the OH temperature does not rise from that 20 seconds before, the reduction of compressor speed will not occur.
- ◇ Restriction Release Condition (in common for all)
 - The restriction will be released when OH temperature < [NDOWN_OFF], and the compressor speed will be increased at a rate of 50 min⁻¹/30 seconds to restore the target speed.

When one unit is operated for cooling

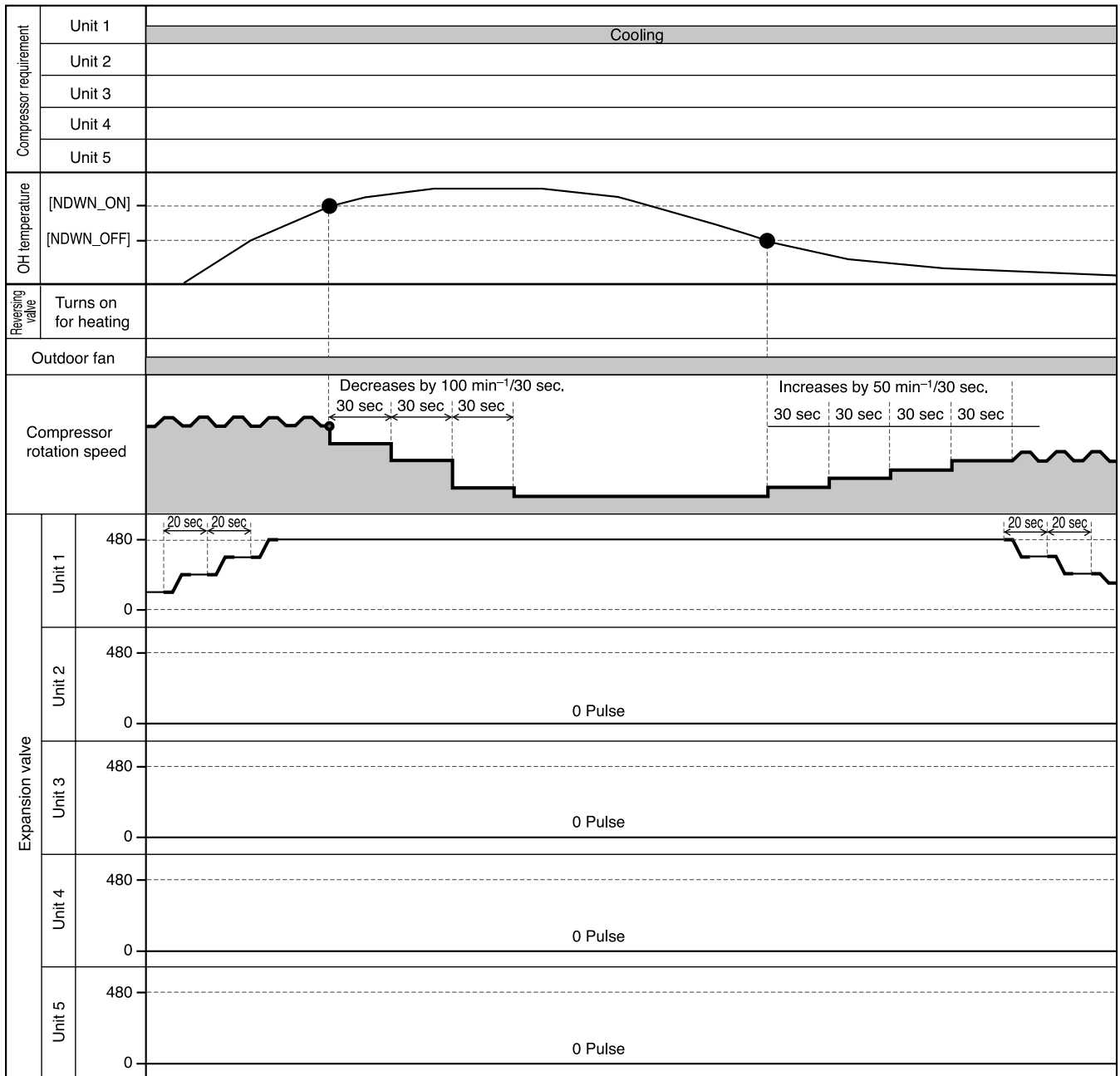

When one unit is operated for heating

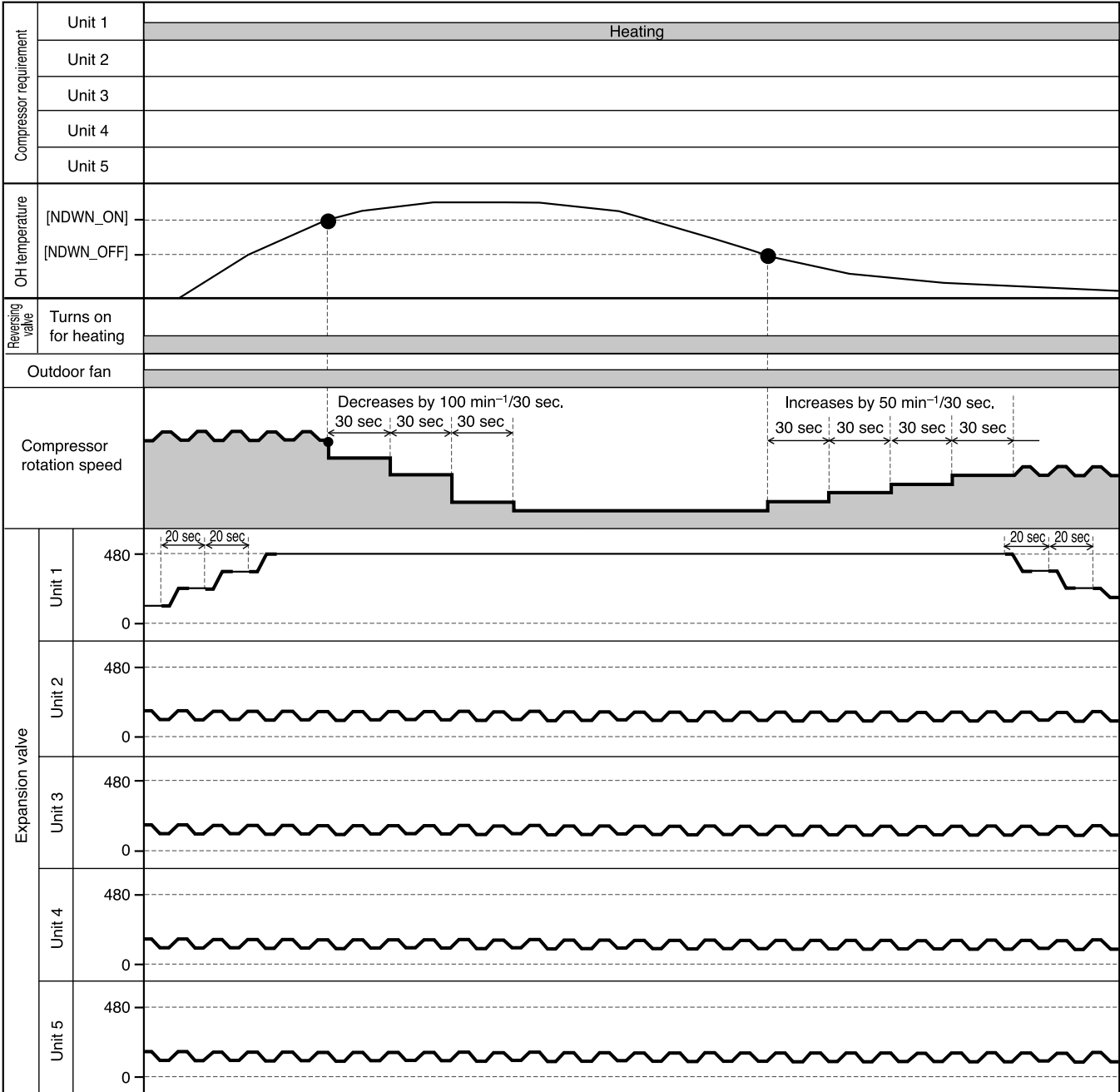

REFRIGERATING CYCLE DIAGRAM

MODEL RAM-90NP5B

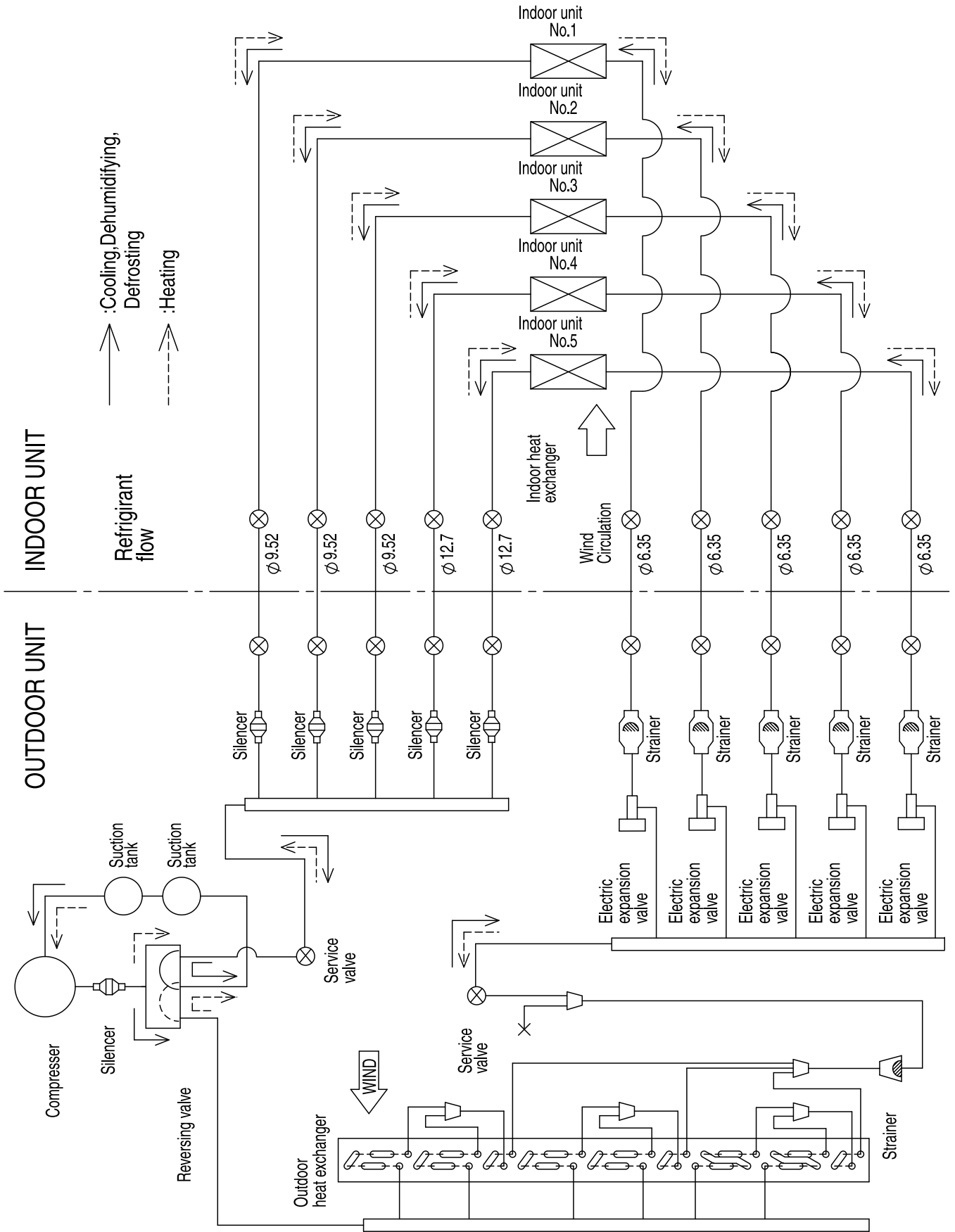

DESCRIPTION OF MAIN OPERATION CIRCUIT

RAM-90NP5B

1. Control Power Supply Circuit

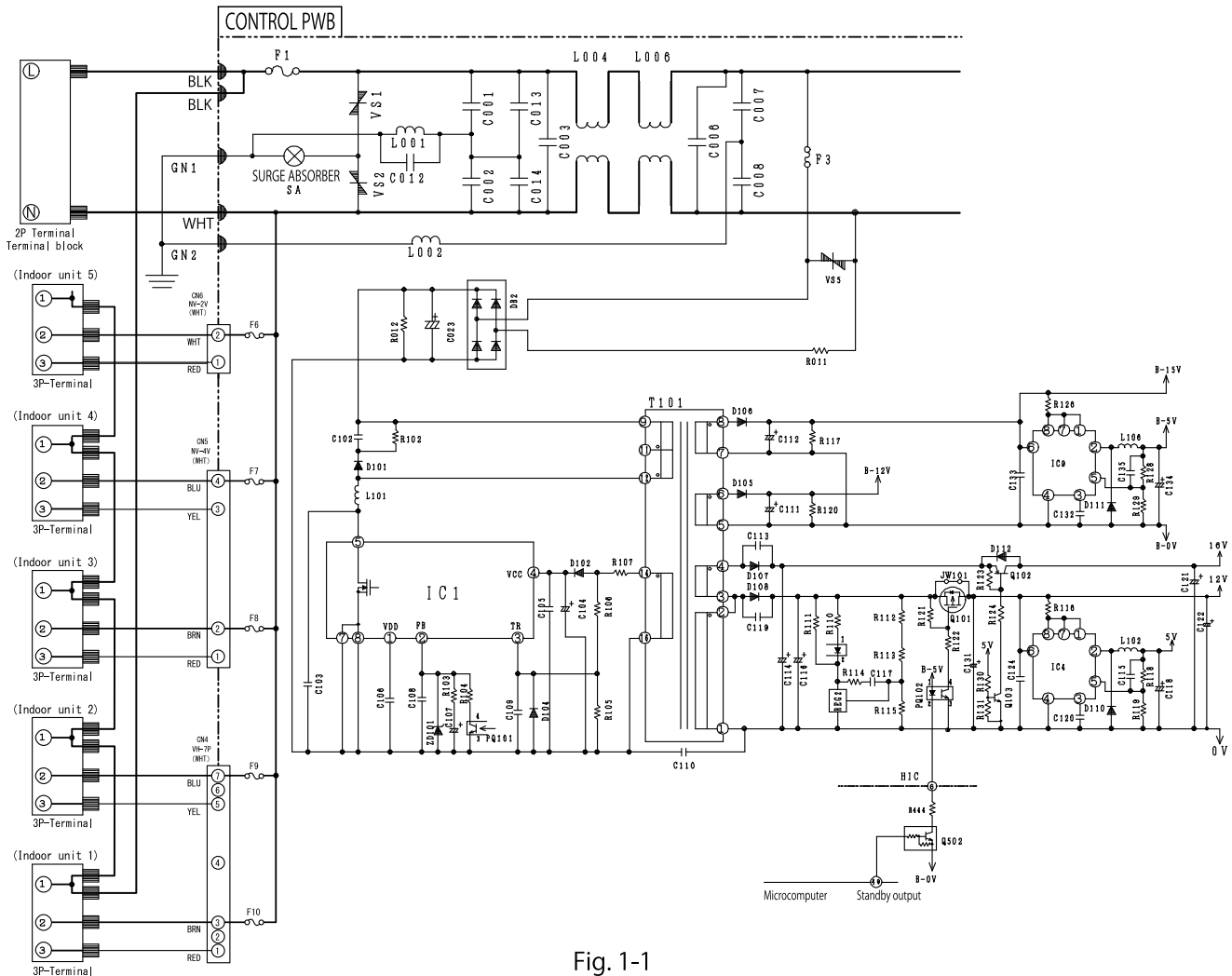

Fig. 1-1

- AC 220~240V power supplied to the 2P terminal block is supplied to DB2 via the noise filter circuit, 2A fuse (F3), and varistor (VS5). High-voltage DC smoothed by DB2 and C023 is used to create DC voltage on the transformer's secondary side by the switch control IC (IC1) and switching transformer.
- Secondary side DC voltage is used in the following six systems:
 - (1) B-15V : Power supply for indoor and outdoor communication circuits
 - (2) B-5V : Power supply for control microcomputer and peripheral circuits
 - (3) B-12V : Operating power supply for electric expansion valve
 - (4) 16V : Power supply for compressor motor drive IPM and fan motor drive IPM
 - (5) 12V : Power supply for reversing valve relay, cooling/heating switching relay, power relay, rush prevention relay, and operating amplifier for compressor motor and fan motor current amplification
 - (6) 5V : Power supply for inverter microcomputer and peripheral circuits
- Primary Components
 - (1) C001, C002, C013, C014, C007, C008, L004, L006
Absorb electrical noise generated during operation of the compressor, and reduce noise level emitted to the power line.
 - (2) Surge absorber, varistor 1, 2, 5
Absorb external surges, such as induced lightning.
 - (3) IC1
IC for control of switching power.
 - (4) IC4
DC/DC converter IC for generating 5V from 12V.
 - (5) IC9
DC/DC converter IC for generating B-5V from B-15V.

● Inverter Microcomputer Power Control

The power to the inverter microcomputer is turned ON/OFF by commands from the control microcomputer. Q502, PQ102, Q101, and Q102 are related.

● Specifications and Checkpoints for Control Power Supply Circuits

Output Name	Voltage Specification	Primary Load	± Measurement Location	Examples of Possible Failure Modes for Output Failures (for Reference)
B-15V output	15.5 ±1.5V	Indoor/outdoor communication	Tester ⊕ terminal: B-15V indicator (J26) Tester ⊖ terminal: B-0V indicator (J20)	LD401 (green), LD402 (green) do not light or blink.
B-12V output	12 +4,-2V	Expansion valve	Tester ⊕ terminal: B-12V indicator (J21) Tester ⊖ terminal: B-0V indicator (J20)	LD351 (red) blinks 5 times and stops.
B-5V output	5 ±0.4V	Control microcomputer thermistor	Tester ⊕ terminal: B-5V indicator (J27) Tester ⊖ terminal: B-0V indicator (J20)	LD353 (green) does not blink. LD351 (red) does not blink. Outdoor unit does not operate.
5V output	5 ±0.4V	Inverter microcomputer	Tester ⊕ terminal: 5V indicator (J23) Tester ⊖ terminal: 0V indicator (C601)	LD351 blinks 8 times.
12V output	12 ±1V	IC2, 3, 4 relay circuits	Tester ⊕ terminal: 12V indicator (J19) Tester ⊖ terminal: 0V indicator (C601)	LD351 blinks 8 times.
16V output	15.5 ±1.5V	Compressor IPM DC fan drive circuit Converter circuit	Tester ⊕ terminal: 16V indicator (J18) Tester ⊖ terminal: 0V indicator (C601)	LD351 blinks 3, 4 or 12 times and then stops.

- Check each voltage. If the above specifications are satisfied, the control power supply circuit can be considered normal.
- Due to high voltage, be particularly careful to avoid electric shock. Further, take care to avoid short-circuit accidents caused by incorrect connection of measuring instruments. Otherwise, the board could be damaged.
- Even after the power is turned off, an electric charge remains in the smoothing capacitor, and a voltage of 270V to 360V is applied between the terminals of the smoothing capacitor.

2. Converter Circuit

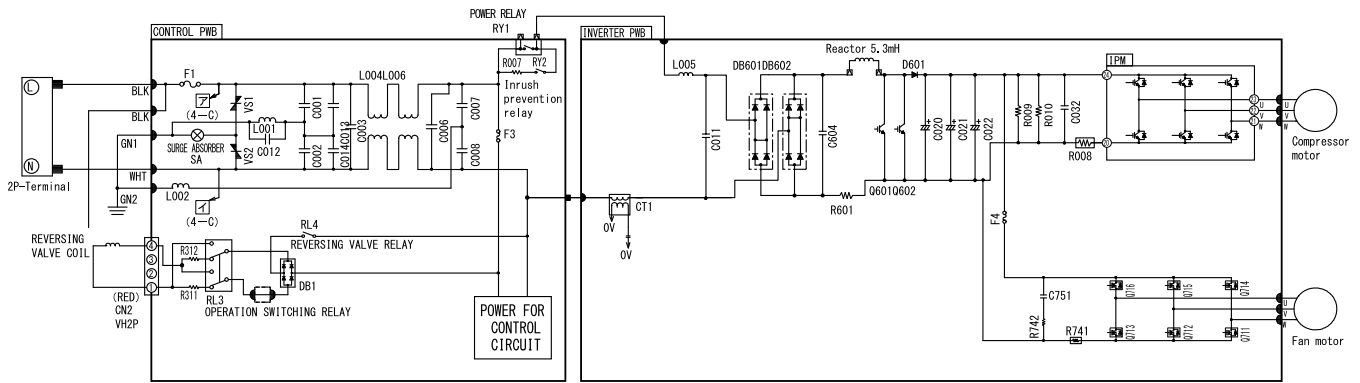

Fig. 2-1

- This circuit rectifies the AC220~240V between L and N on the 2P terminal block, and creates a DC voltage. During operation of the compressor, the rectified circuit voltage is approximately (DC320V - 360V).

- Primary Components

(1) Intelligent Power Module (IPM)

used for configuration of inverter section.

Reference:

- In case of IPM failure or poor connection, immediately after starting the compressor, it might stop due to abnormal speed reduction, switching failure, Ip cut, etc.

(2) Diode bridge (DB1, DB601, DB602)

Rectifies AC200V between terminal blocks ① and ② into DC.

Reference:

- If there is a failure in the diode bridge (DB601, DB602), DC voltage is not generated and operation might not occur.

(3) Smoothing Capacitor (C019~022, 500 μ F, 450V)
 Boosts and smoothes (averages) voltage rectified by the diode.

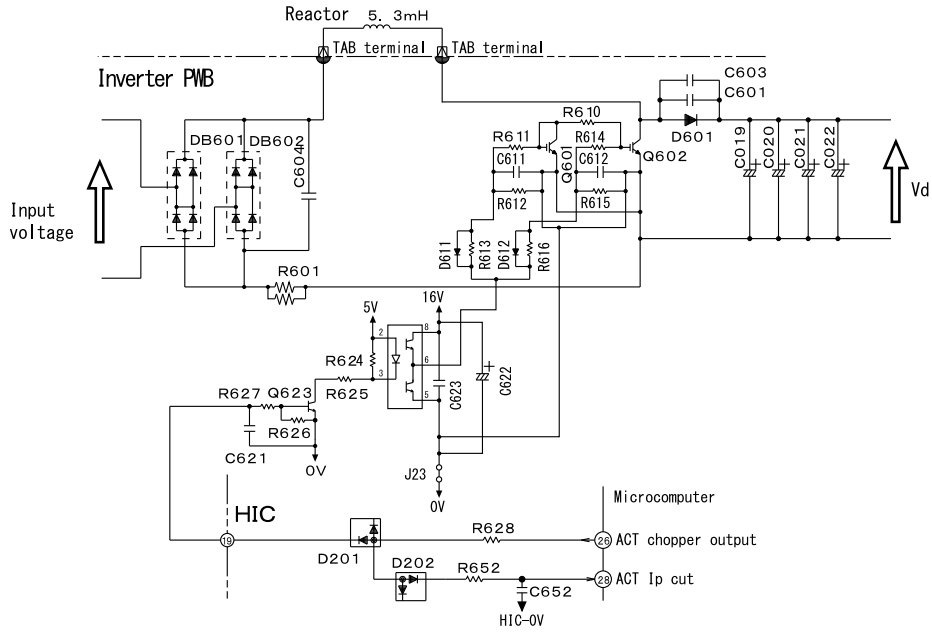

Fig. 2-2

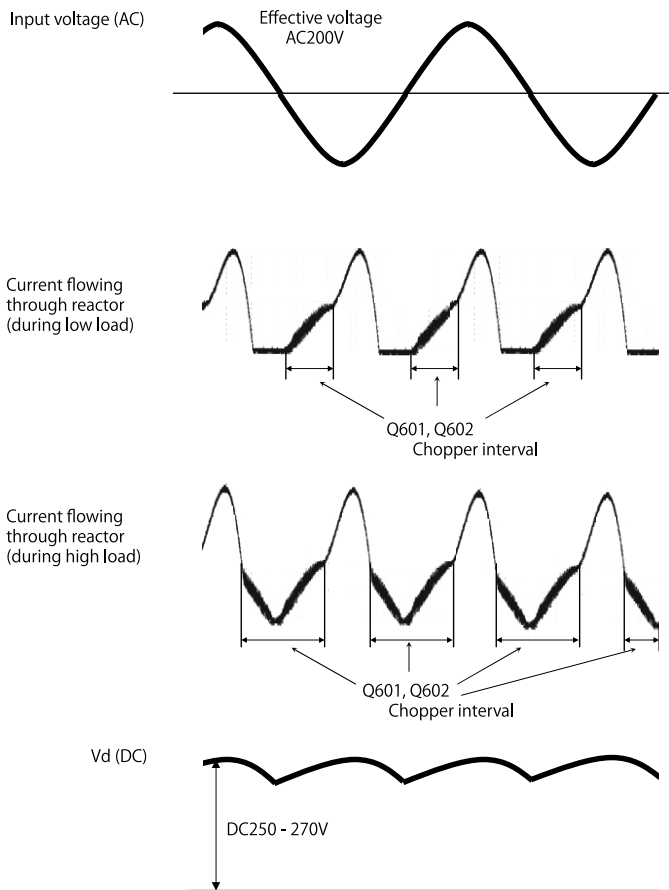

Fig. 2-3

(4) IGBT for improving power factor (Q601, Q602)

When load on the compressor increases, the power factor is improved by applying current to the chopper interval between Q601 and Q602 shown in Fig. 2-3.

Inspection when Timer Lamp on Indoor Unit Blink Once

Note: Be sure to turn the power OFF before performing the following inspection.

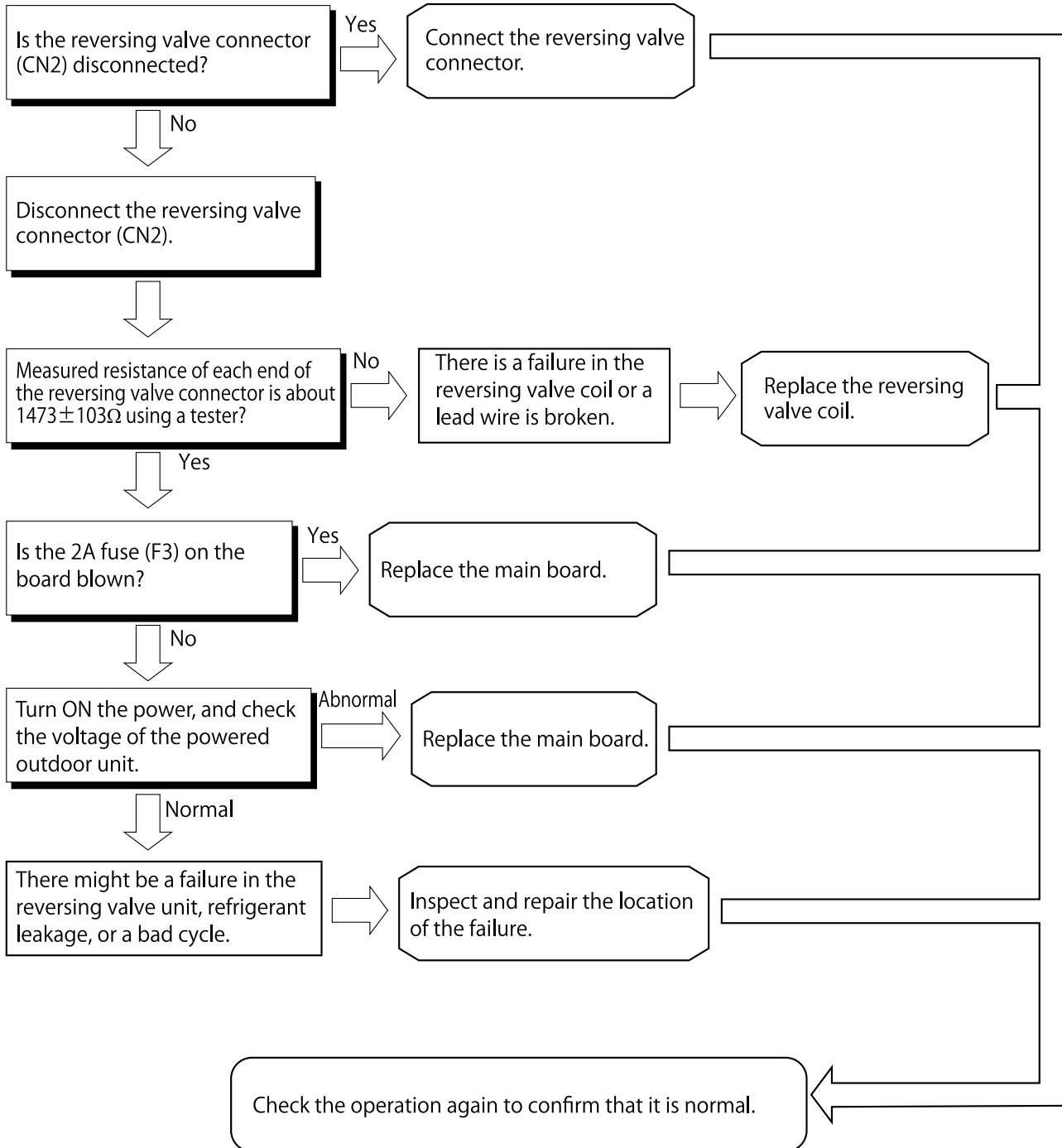

4. Temperature Detection Circuit

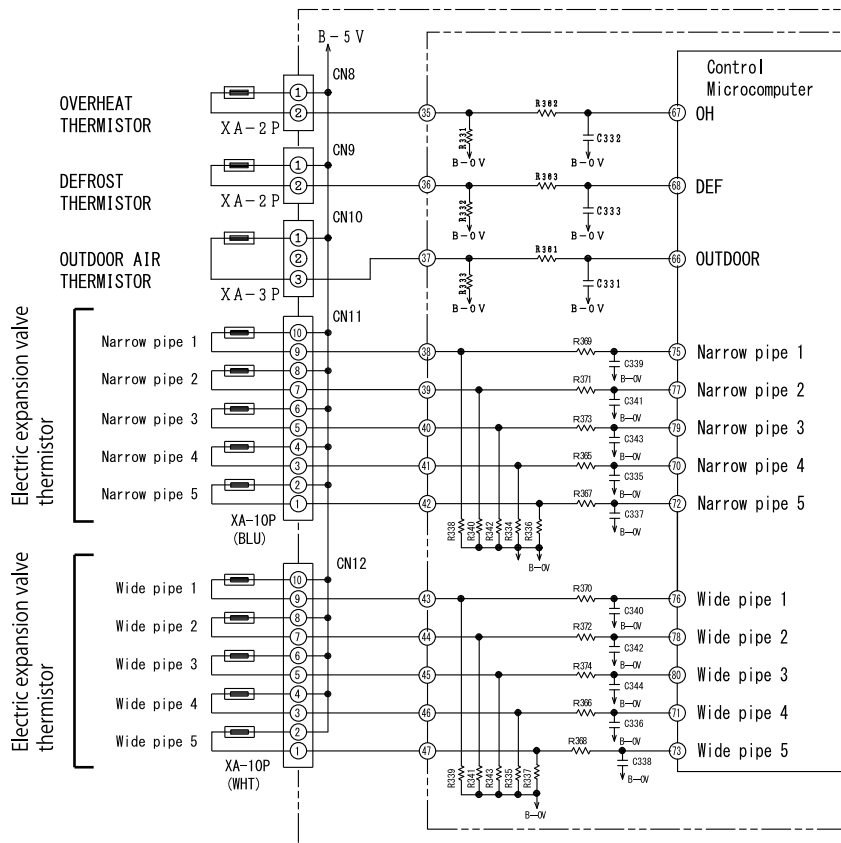

Fig. 4-1

- The OH thermistor circuit detects compressor head surface temperature, the DEF thermistor circuit detects defrost operating temperature, and the outside air temperature thermistor circuit detects the outside air temperature. In addition, the electric expansion valve thermistor (narrow pipe 1) detects the temperature of narrow pipe going to indoor unit 1 and (wide pipe 1) detects the temperature of the wide pipe going to indoor unit 1. (Narrow pipe 2) and (wide pipe 2) are for indoor unit 2.
- Thermistors are negative resistance elements. The resistance value grows smaller as the temperature rises, and grows larger as the temperature falls.
- If the compressor overheats, the resistance value of the OH thermistor grows smaller. B-5V is divided between the OH thermistor and R331, and therefore the voltage of pin 67 on the control microcomputer rises.
- The voltage of pin 67 on the control microcomputer is compared with the value set and stored internally. If the set value is exceeded it is determined that the compressor has overheated, and operation is stopped.
- If frost accumulates on the outdoor heat exchanger, the temperature of the heat exchanger will fall rapidly. Therefore, the resistance value for DEF thermistor grows large and the voltage of pin 68 on the microcomputer falls. If this voltage drops below the value set and stored internally, defrosting of the control microcomputer will start.
- Outdoor temperature is read by the outdoor temperature thermistor (voltage of pin 69 on the microcomputer). Commands from the indoor microcomputer, values read from the outdoor temperature thermistor, and values read from the OH thermistor are taken into account to control the speed of the compressor and the speed of the outdoor fan. Typical values that indicate the relationship between outdoor temperature and voltage are shown below.

Table 4-1

Outdoor temperature (°C)	-10	0	10	20	30	40
Voltage (V) at both ends of R333	1.19	1.69	2.23	2.75	3.22	3.62

- The temperatures at narrow pipe 1 - 5 and wide pipe 1 - 5 are read by thermistors, and the amount that electric expansion valves 1 - 5 are opened is changed to control the distribution of refrigerant.

Reference:

When a thermistor is open and disconnected, pins 66 - 68, 70, 71, and 73 - 80 on the control microcomputer are approximately 0V. When there is a short-circuit in a thermistor, these pins are approximately 5V, LD351 lit, and LD352 blinks. The number of blinks by LD352 indicates the thermistor in question. However, if a short-circuit error occurs in the OH thermistor, blinking mode starts 12 minutes after the compressor starts operating.

5. Electric Expansion Valve Circuit

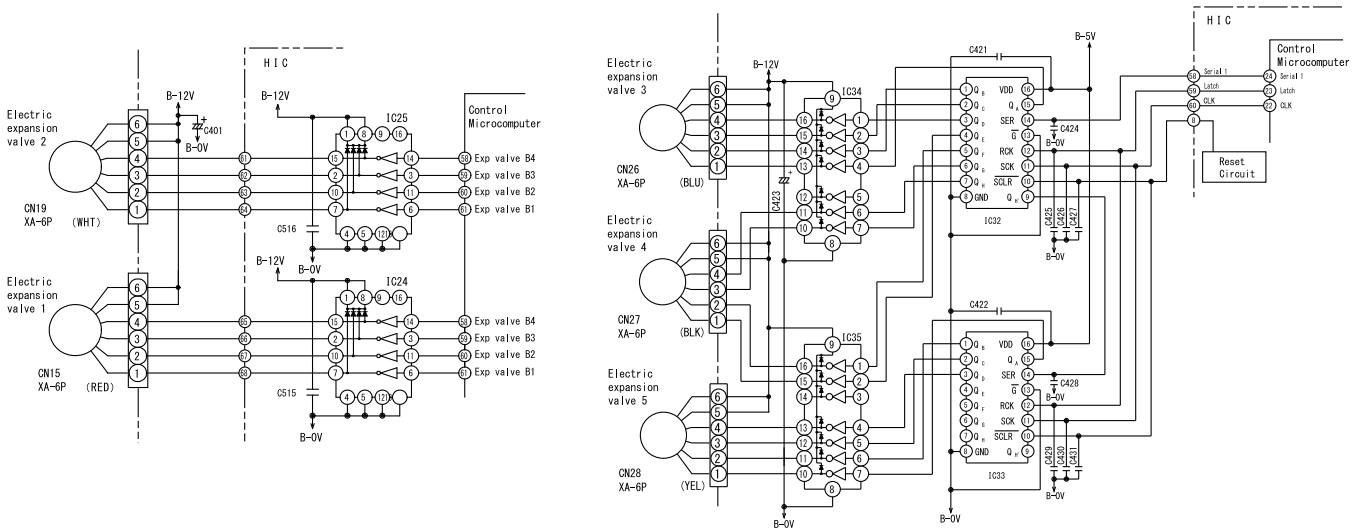

Fig. 5-1

- There are 5 electric expansion valves for indoor units 1-5.
- The electric expansion valves are powered by B-12V for expansion valves. 1- or 2-phase current is applied to 4-phase wound wires, switching the poles of the wound wires to control valve openings.
- The relationship between the switching direction of the current phase and the open/close direction of the valves is shown in the following table. When current is applied, approximately 0.9V passes through pins ①-④ of CN15, CN19, CN26, CN27 and CN28; when no current is applied, it is approximately 12V. When the power is reset, the expansion valve is initialized for approximately 35 seconds. During initialization, use a tester to measure pins ①-④ on CN15, CN19, CN26, CN27 and CN28. If there is a pin that does not change at approximately 0.9V or 12V, there is an abnormality in that expansion valve or the control microcomputer.
- The logic waveform for when an expansion valve operates is shown in Fig. 5-2.

Table 5-1

CN15, CN19, CN26, CN27, CN28 Pin No.	Lead wire	Power conditions								
		1	2	3	4	5	6	7	8	
④	White	ON	ON	OFF	OFF	OFF	OFF	OFF	OFF	ON
③	Yellow	OFF	ON	ON	ON	OFF	OFF	OFF	OFF	OFF
②	Orange	OFF	OFF	OFF	ON	ON	ON	OFF	OFF	OFF
①	Blue	OFF	OFF	OFF	OFF	OFF	ON	ON	ON	ON

Operation mode
 1→2→3→4→5→6→7→8 VALVE CLOSE
 8→7→6→5→4→3→2→1 VALVE OPEN

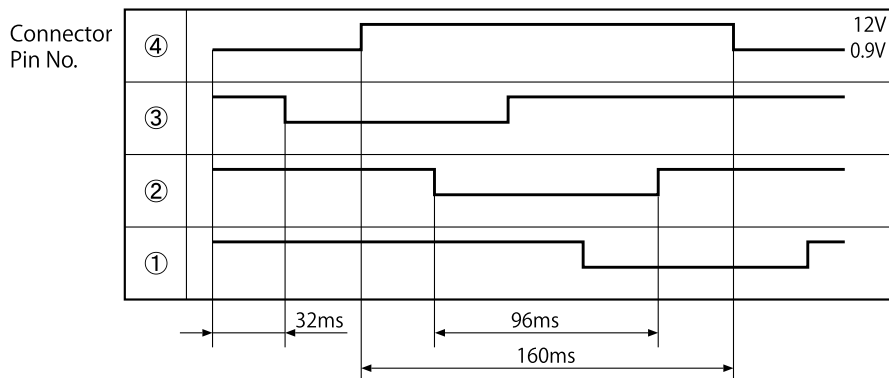

Fig. 5-2

When controlling an expansion valve, the temperature of the compressor head is detected and then the opening is adjusted to stabilize the valve to the target temperature. This control cycle is performed once every 20 seconds, and a few pulses are output.

- Two (IC32, IC33) 8-bit type shift register ICs that convert serial signal input to parallel and output the parallel signals are used on the circuits of electric expansion valves 3,4 and 5.
- An example of circuit operation when an expansion valve is powered is shown in the time chart in Fig. 5-3.
 - ① A clock signal (16 cycles at $750\mu\text{s}/\text{cycle}$) is output from pin ② on the microcomputer. (One cycle for the clock signal is $500\mu\text{s}$ off, $250\mu\text{s}$ on.)
 - ② A serial signal #1 of the power pattern is synced with the clock signal and output from pin ④ of the microcomputer. #1 The serial signal is the pattern of the current applied to phase 1 or phase 2 of a 4-phase wound wire on an expansion valve, that has then been converted to serial format. A serial signal is output so that the center of the ON serial signal (Hi-level $500\mu\text{s}$) aligns with the rising edge of the clock signal.

The content of the shift register in IC is updated by operations ① and ② described above.

Next, $250\mu\text{s}$ after the ON signal is output for the 15th cycle of the clock signal,

- ③ the latch signal from pin ③ on the microcomputer is turned OFF (Lo-level $500\mu\text{s}$) and then ON again (Hi-level).
- ④ After the time required to apply current has elapsed, if powering of the expansion valve is required the cycle returns to ① and repeats the operation.

With the operation described above, the opening of expansion valves is controlled while applying current to phase 1 or phase 2 of a 4-phase wound wire on an expansion valve, according to the content of the shift register updated when the current is applied. When the opening of the expansion valve reaches the target amount, the stop pattern described in ② above is applied and then operations ① - ④ are performed to complete the control of the expansion valve.

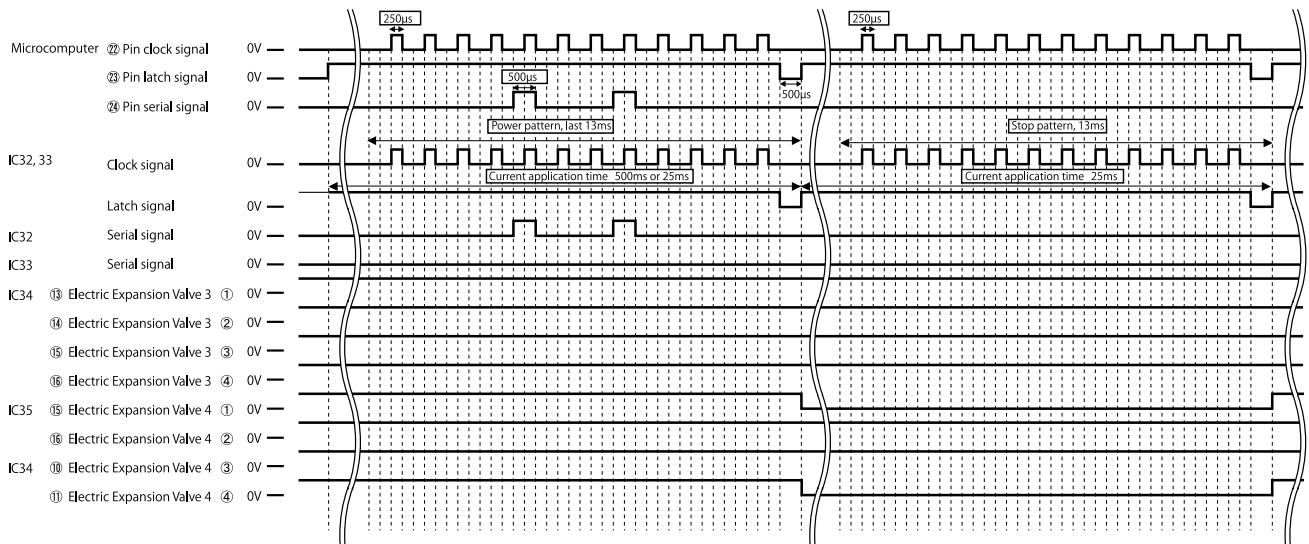

Fig. 5-3 Time Chart

6. Outdoor Fan Motor Control Circuit

- This outdoor unit is equipped with a built-in outdoor fan motor control circuit.

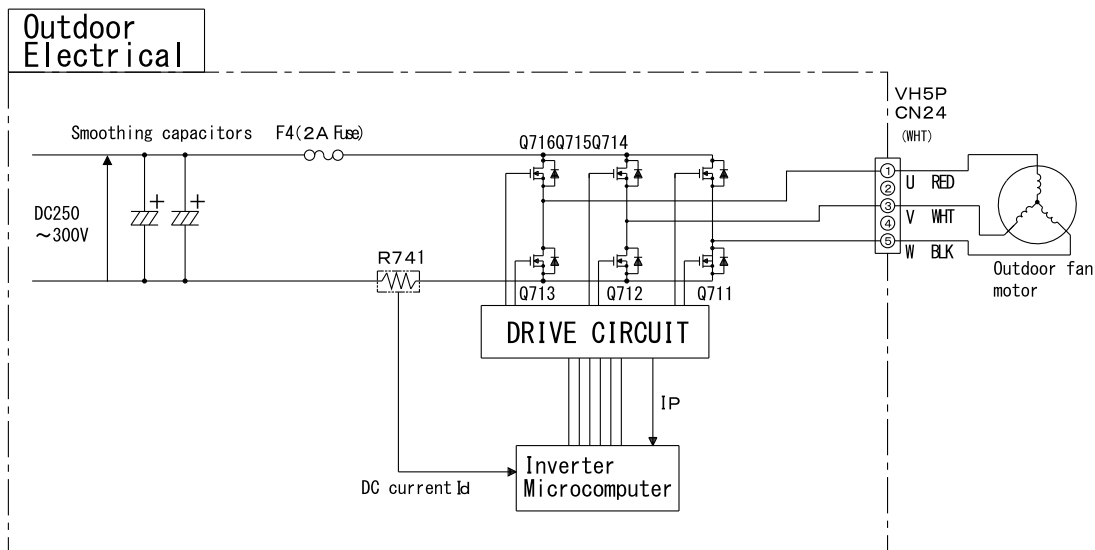

Fig. 6-1

Based on operation commands from the indoor microcomputer, the speed of the outdoor fan motor on this unit is determined by the control microcomputer and controlled by the inverter microcomputer.

Actual speed is estimated based on DC waveforms from R741 to control the speed so that it matches the operational commands.

Overcurrent and other failures in the outdoor fan motor are detected by the magnitude of the direct current.

(1) Control of outdoor fan motor at startup

If the propeller fan is already rotating at the start of operation, due to disturbances such as strong wind, operational behavior will vary according to the direction and speed of such rotation as described below. Favorable wind is defined as wind that blows outward from the mouth ring.

- | | |
|-----------------------|---|
| Strong headwind | : Control is not performed, to protect the equipment, and the propeller is blown in the opposite direction by the wind. The unit starts automatically once the wind has weakened. |
| Headwind | : After the speed reduces gradually and finally stops, the speed is controlled in the normal direction. |
| Favorable wind | : The speed of the fan is controlled normally. |
| Strong favorable wind | : Control is not performed, to protect the equipment, and the propeller is blown in the normal direction by the wind. The unit starts automatically once the wind has weakened. |

(2) Control of outdoor fan motor during operation

The speed of the propeller fan might drop during operation of the outdoor fan motor due to disturbances such as strong wind.

If such conditions continue for a long period of time, the propeller fan will stop. (Self-diagnosis lamp LD351: Blinks 11 times)

When the fan is restarted, the operation described in (1) above is used.

(3) Confirmation method when self-diagnosis lamp LD351 blinks 12 times

If LD351 on the control board blinks 12 times (fan lock detected) and operation stops, use the following procedure to check the unit.

1. Mechanical locking caused by the insertion of foreign objects such as sticks into the propeller fan or freezing due to the accumulation of snow will cause fan lock to be detected and result in shutdown.
Remove any foreign objects.
2. Check whether CN24 is securely inserted. A poor connection will cause a fan lock detection and result in shutdown. If CN24 is loose, insert it securely.
3. Strong wind around the outdoor unit might cause a fan lock detection.
Check if the unit restarts. (Several minutes might be required for the unit to restart.)
If the unit continues to operate after restarting, there is no failure in the outdoor fan motor or electrical components.
4. Perform a check of the outdoor fan motor. The procedure is shown below.

Procedure for Checking the Outdoor Fan Motor

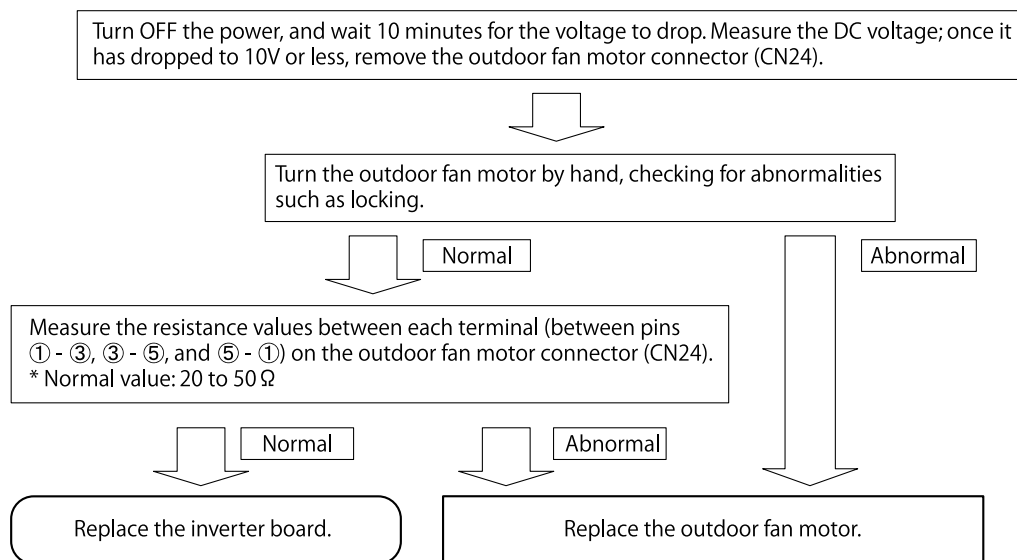

5. Insert the outdoor fan motor connector (CN24).

* Also use the above procedure if F4 (2A fuse) is blown.

Caution

* The power supply for the outdoor fan motor is also used as the power supply for the compressor, and therefore has a high voltage (DC280 to 340V). Use sufficient caution to avoid electric shock when checking operations and performing repairs.

8. Indoor/outdoor communication circuit

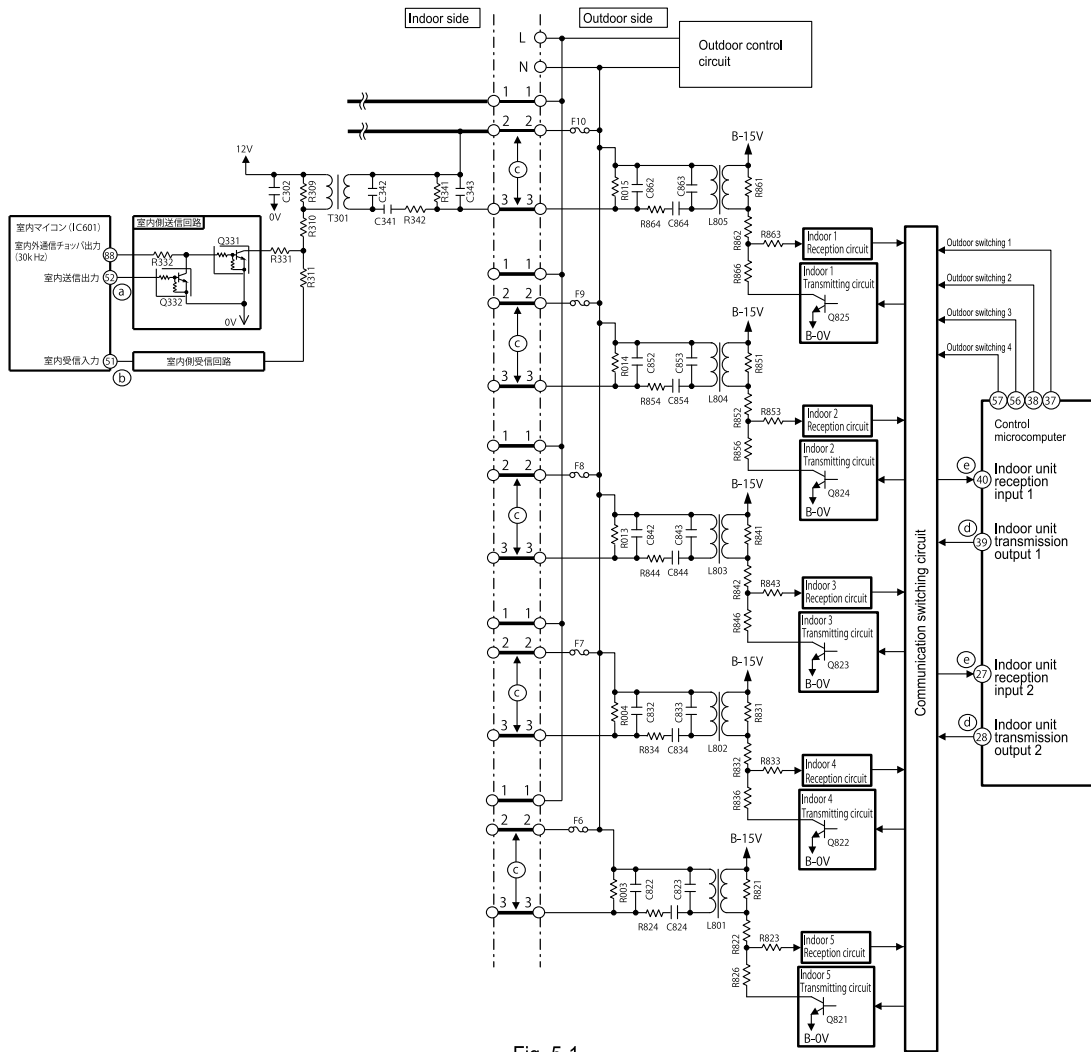

Fig. 5-1

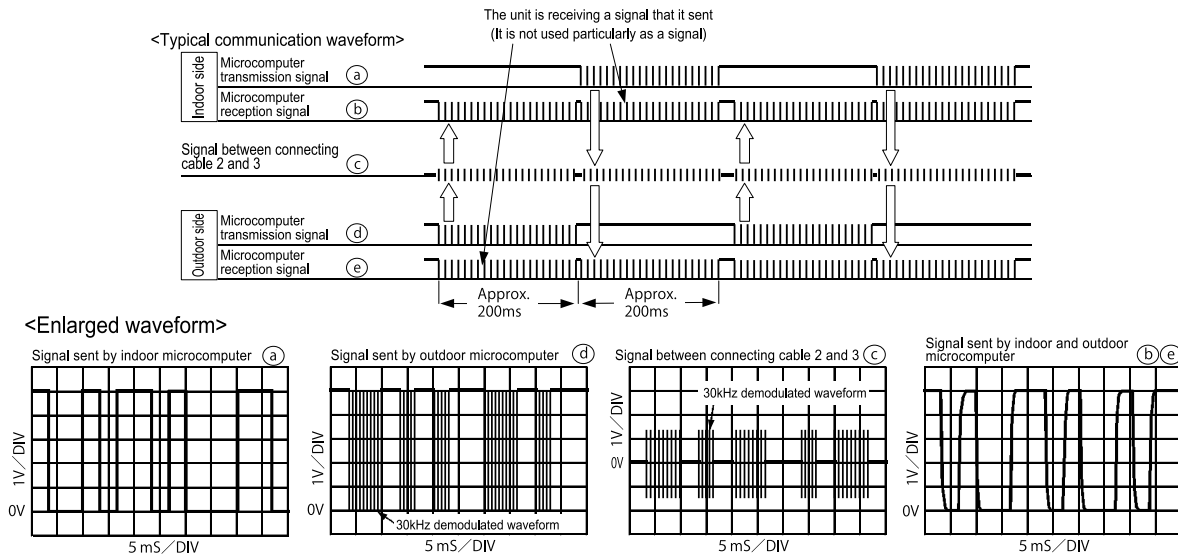

Fig. 5-2

- * Indoor and outdoor communications are conducted by using lines 2 and 3 of connecting cable. Line 2 of connecting cable is share with a transmission channel that powers the indoor unit.
- * Data communicated between the indoor and outdoor units are outputted from the microcomputer as serial signals and are transmitted as demodulated by a 30kHz carrier wave.

Check

If the communication fails between the indoor and outdoor units for some reason, the product will give a self-diagnosis display either by "the timer lamp blinking 3 times" or "the the timer lamp blinking 12 times" depending on the cause.

14 TROUBLE SHOOTING

PRECAUTION FOR CHECKING



DANGER

1. Remember that the 0V line is biased to 162V in reference to the ground level.
2. Also noted that it takes about 10 minutes until the voltage fall after the power switch is turned OFF.

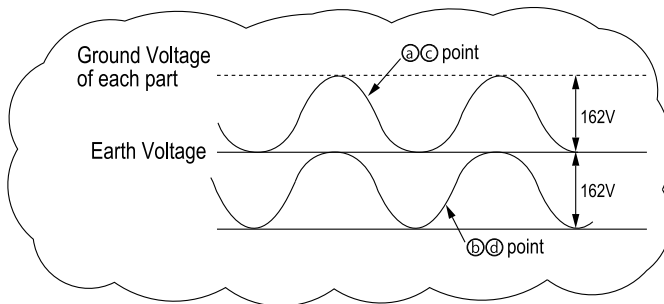
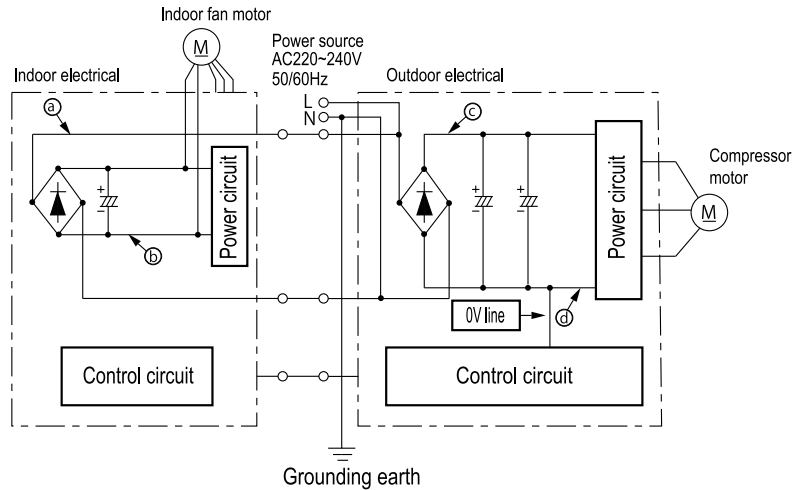
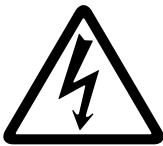

DANGER

When using an oscilloscope, never ground it. Don't forget that high voltages as noted above may apply to the oscilloscope.

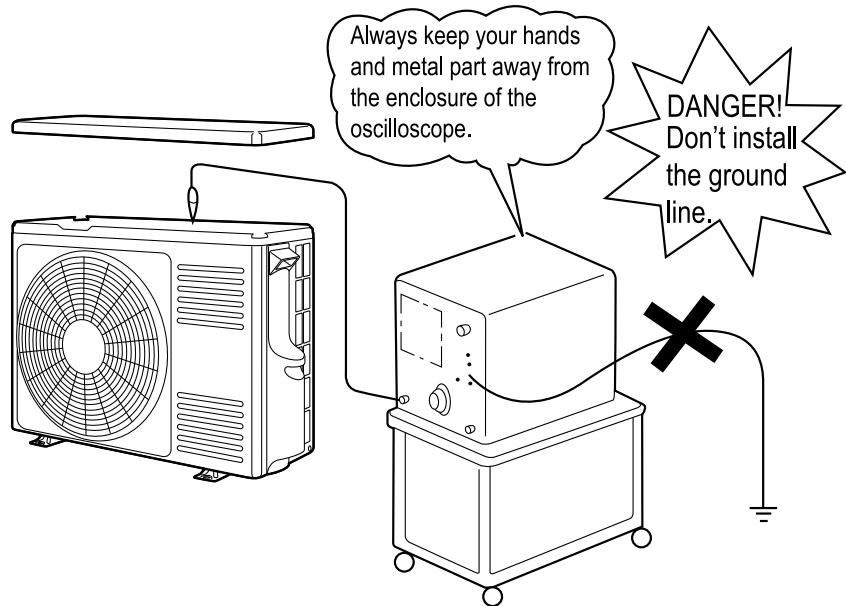

SELF CHECK

When it is difficult to judge whether the compressor or the electrical part is faulty resulting self diagnosis lamp blink 2,3,4 or 5 times, please confirm first the compressor terminal insulation by using mega ohm checker. If the insulation is normal, proceed to below self-check method.

■ Self-check diagnosis method

1. Switch OFF main power supply. (Wait until DC voltage fully discharged :15 minutes or more)
2. Un-insert jumper wire connector at CN30.
3. Switch ON main power supply. (LD352 will blink 1 time)
4. Press and hold TEST SWITCH for more than 1 second.
 - It energizes to IPM and the compressor motor one by one, and the short-circuit and opening are confirmed.
5. Self-check diagnosis result will appear.
 - The content of diagnosis result shall refer to below table.

■ Self-check diagnosis result

[SELF-CHECK] DIAGNOSIS RESULT		
LD301	DIAGNOSIS CONTENT	REPAIR METHOD
1 TIME BLINK	ELECTRICAL OK.	CHANGE COMPRESSOR.
2 TIMES BLINK	PEAK CURRENT CUT OFF SIGNAL DETECTED.	CHANGE INVERTER P.W.B.
7 TIMES BLINK	COMPRESSOR CURRENT ABNORMAL.	COMPRESSOR CONNECTOR LOOSE=>CHECK CONNECTOR. AFTER CHECK COMPRESSOR CHANGE INVERTER P.W.B.
10 TIMES BLINK	DC VOLTAGE ABNORMAL.	AC VOLTAGE ABNORMAL (BEYOND RATED $\pm 10\%$) ↳ CONNECT WITH CORRECT AC VOLTAGE. AC VOLTAGE NORMAL (WITHIN RATED $\pm 10\%$) ↳ CONNECTOR (CN23,CN25) BAD INSERTION => CHECK CONNECTOR OTHER => CHANGE BOTH MAIN & INVERTER P.W.B.
13 TIMES BLINK	EEPROM READING ERROR.	CHANGE INVERTER P.W.B.

In case abnormality found at the checking result, please confirm the connecting cord having problem or not before replace the defect part according to the table of self-check diagnosis result.

In case no abnormality found at electrical part, insert back the jumper wire connector at CN30 as original condition before it can be use.

※ If forgot to insert back as per original condition, the system will not operate until 3 minutes has lapsed after restore the power supply.

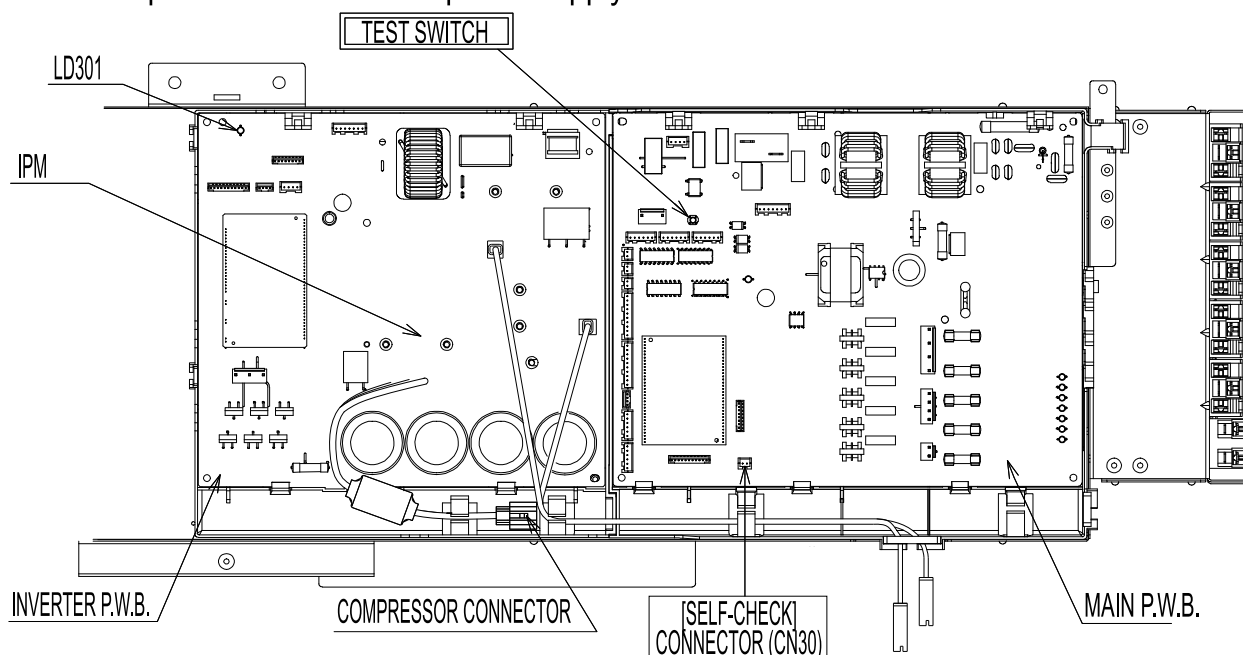

Collect refrigerant using test switch operation

1. Turn OFF the breaker and wait for 1 minute or more before turn ON back the breaker.
2. Detach the electrical cover of outdoor unit and ensure LD353 is blinking once.
3. Wait 20 seconds or more before pressing the test switch for 1 second or more to start the forced cooling operation.
4. Pressing the test switch again for 1 second or more will stop the operation.

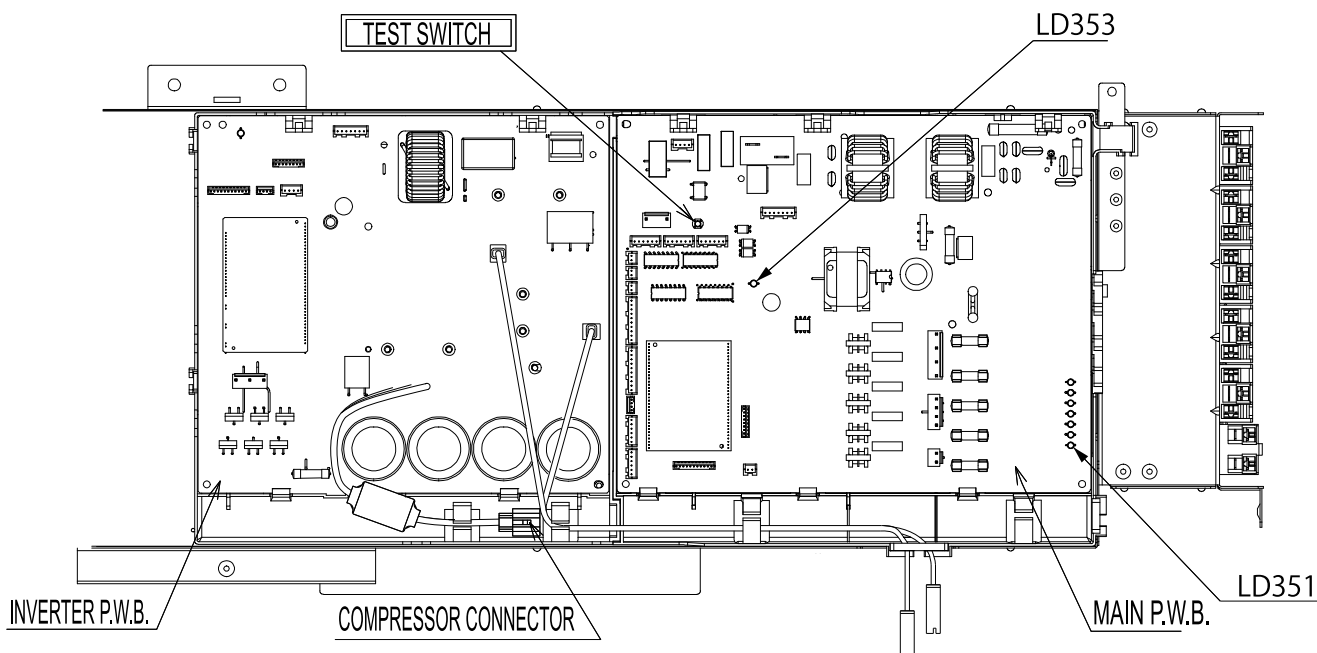

※ Cautions

1. Do not any circumstances operate the outdoor unit for more than 5 minutes.
2. Doing work with the compressor connector removed will cause the LD351 to blink 4 times. It will not start the operation.
3. For another test run, turn OFF the breaker and turn it back ON to reset the power supply. (The test switch is accepted only once after power ON. After operation by remote controller, it is not accepted.)
4. When the operation with the test switch is done, turn OFF the breaker.

How to operate the outdoor unit independently

1. Connect the large dia. pipe side and small dia. pipe side service valves using a pipe.

Connect the small diameter service valve and the large diameter service valve using the reducing union and copper pipe as shown on the right.

Charge refrigerant of 300g after vacuuming (※1)

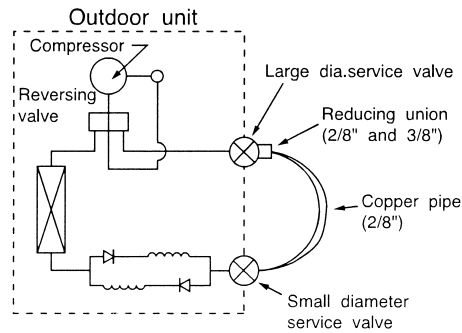

Parts to be prepared

- (1) Reducing union
2/8" (6.35mm)
3/8" (9.52mm)
- (2) Copper pipe (2/8" and 3/8")

Do not operate more than 5 minutes

The operation method is the same as "Collect refrigerant using test switch".

※1 The charging amount of 300g is equivalent to the load in normal operation.

Lighting mode of the self-diagnosis lamp

1 Mounting location of the self-diagnosis lamp

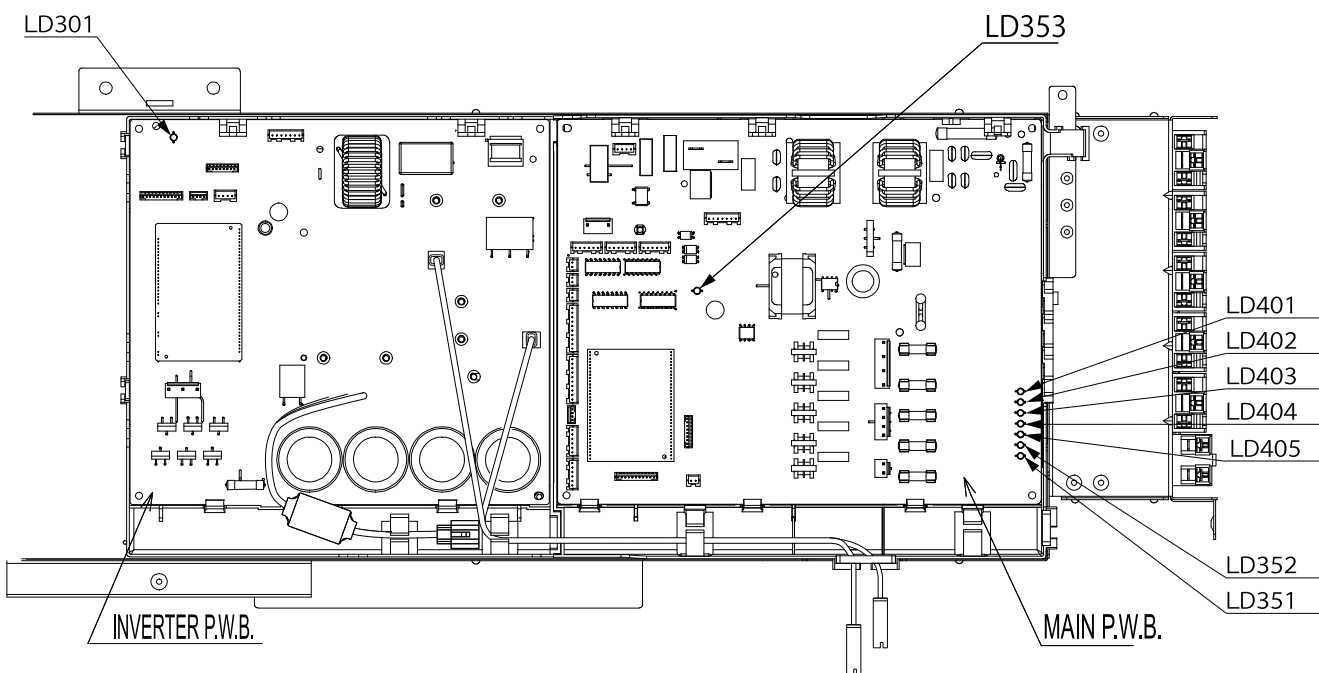

Refrigerant cycle check (gas leak or compressor failure)

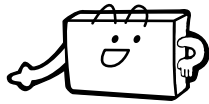

Operate the unit after re-connect the connector for compressor.

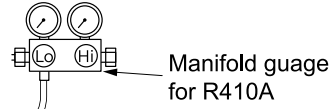

Manifold gauge for R410A



Refer to cycle inspection mode.



Is the self-diagnosis lamp shown as per this table?

LD351	2 times blink	3 times blink	4 times blink	5 times blink	ON
LD352	OFF	OFF	OFF	OFF	1 time blink
Time to blink	2~3sec			About 10sec	Within 30min
Suspect failure item	Compressor				Gas leak

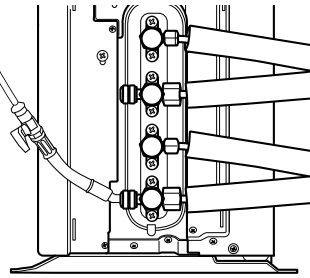

Outdoor electrical assembly

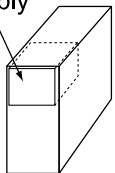

Normal

Abnormal (gas leak)



Outdoor electrical assembly
 ■ Check drive signal using PRD checker

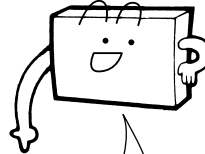

It is a gas leak.
 Please repair and re-charge the gas.



Normal

(When the self-diagnosis lamp is the same to above figure lighting mode)

Re-charge gas

Compressor is abnormal.
 Please change it and re-charge gas.

Change compressor

Perform final basic operation check

Checking Electrical Parts of Outdoor Unit

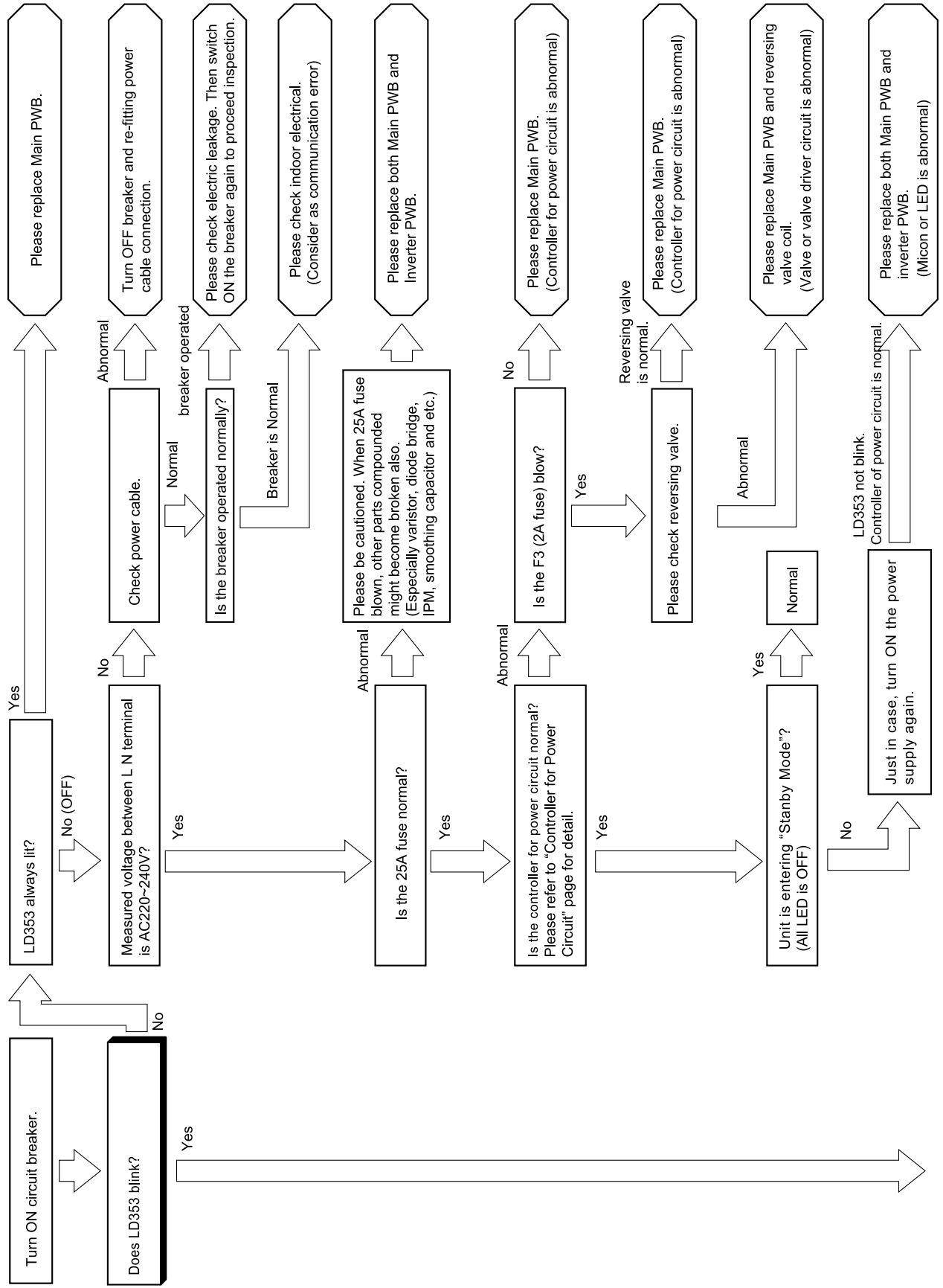

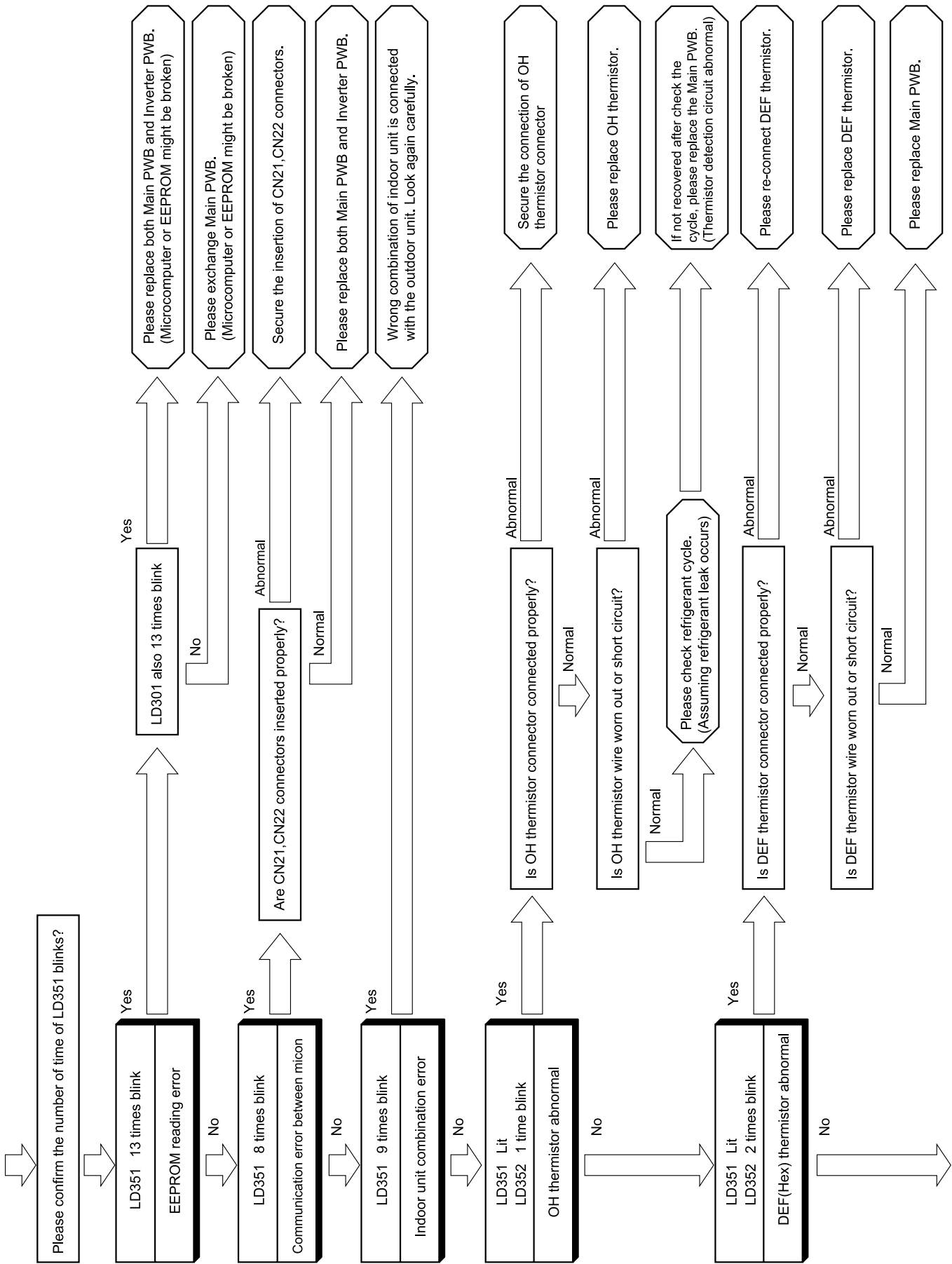

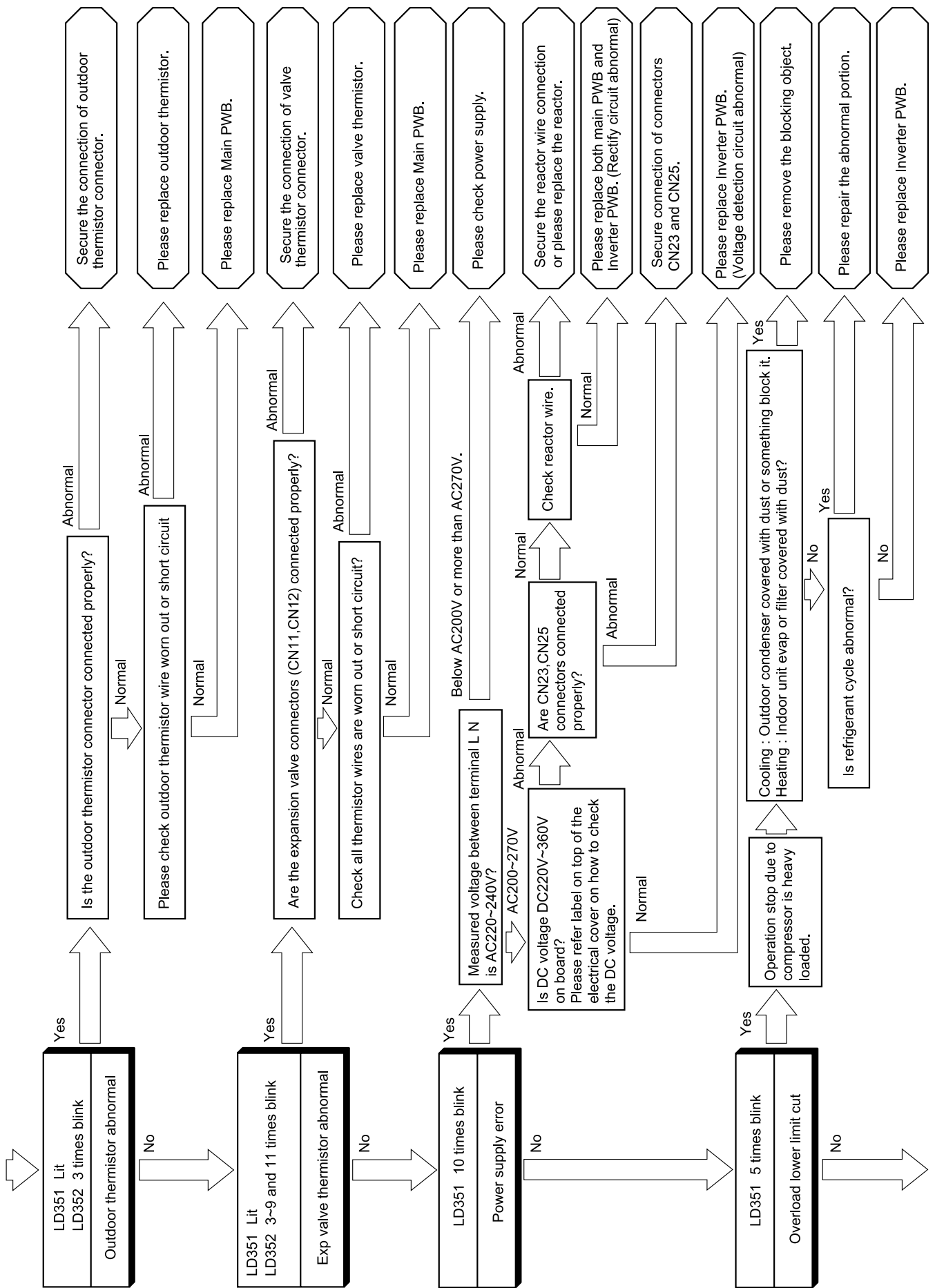

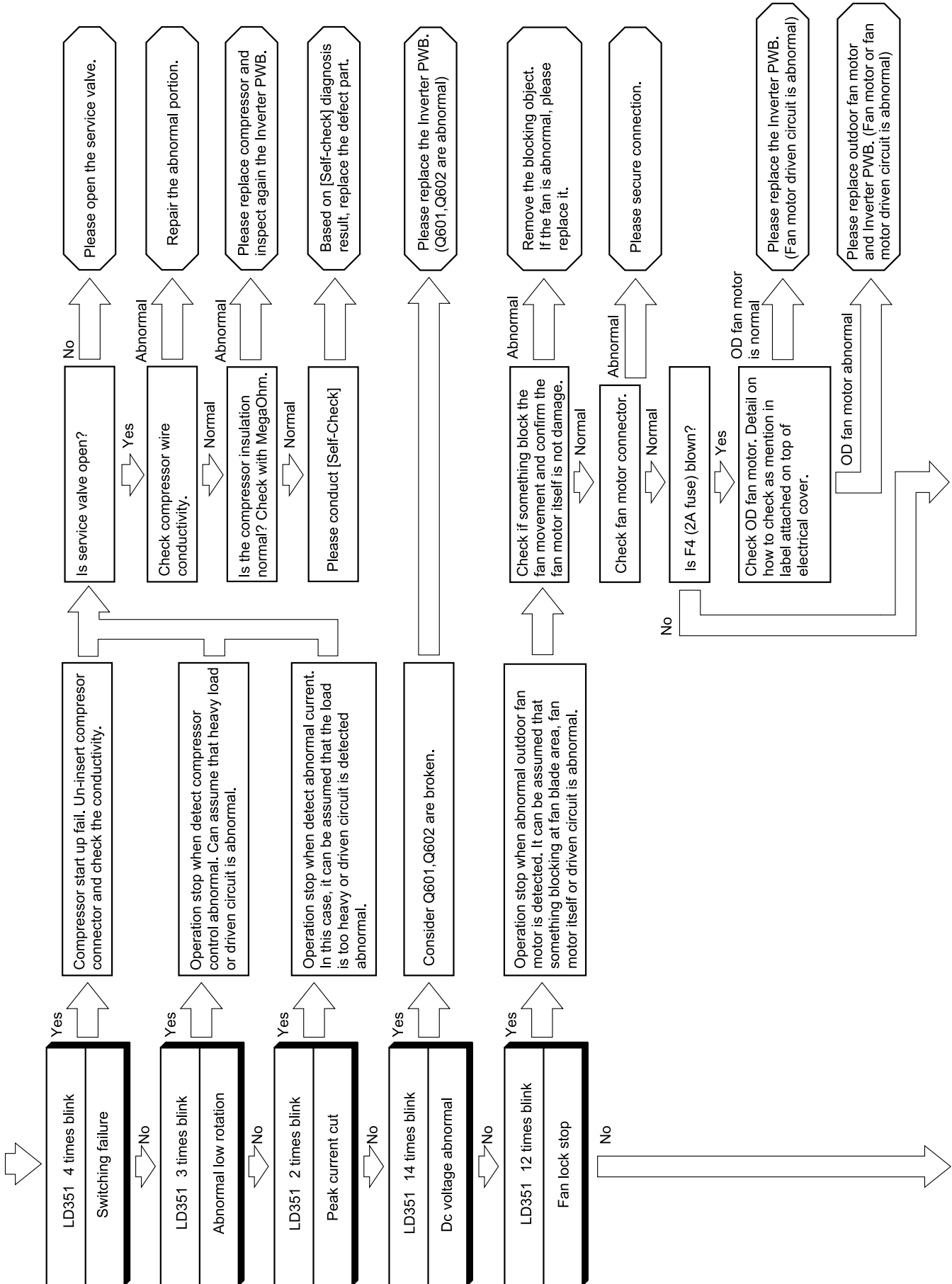

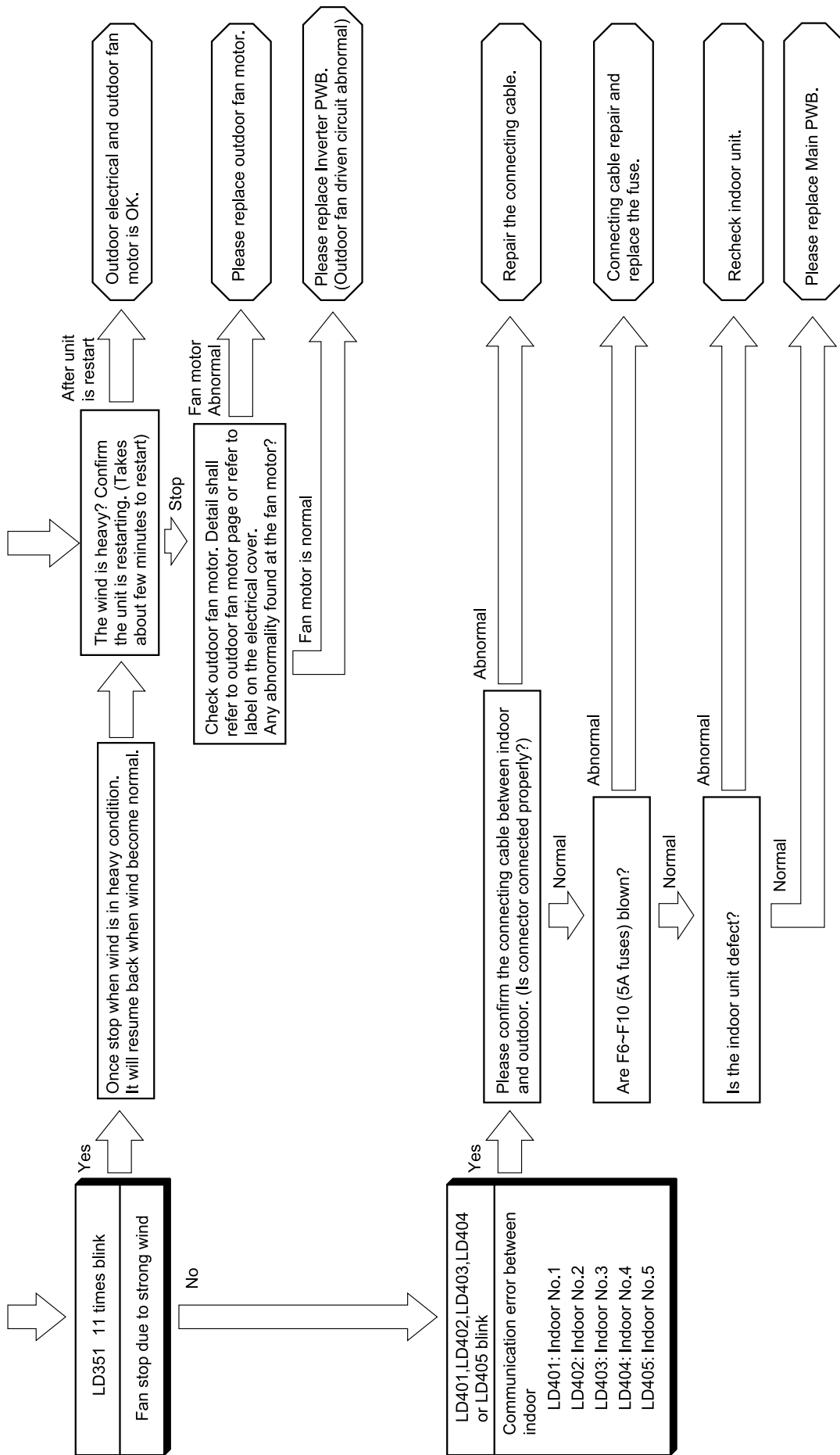

DISMANTEL AND ASSEMBLY PROCEDURE

■ RAM-90NP5B

1. Electrical parts (preparation to remove board)

- (1) Remove screw that fix the service valve cover and push it down to take it out.
- (2) Remove the screws on both sides of top cover and then remove the top cover.

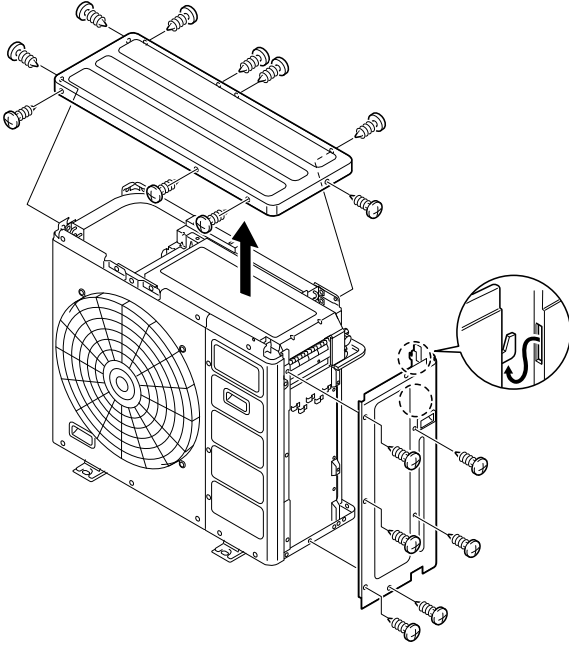

- (2) Remove the screws that holding the electrical cover and then remove the cover.

2. Dismantle procedure of inverter board

- (1) Un-insert connectors (4 places) and TAB terminal (4 places).

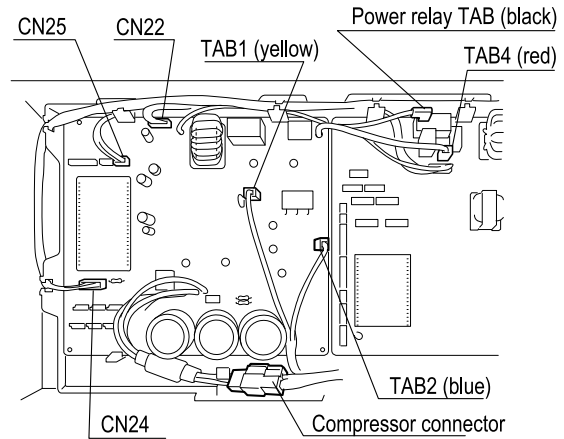

- (2) Remove screw (7 pieces) that fixed the board.

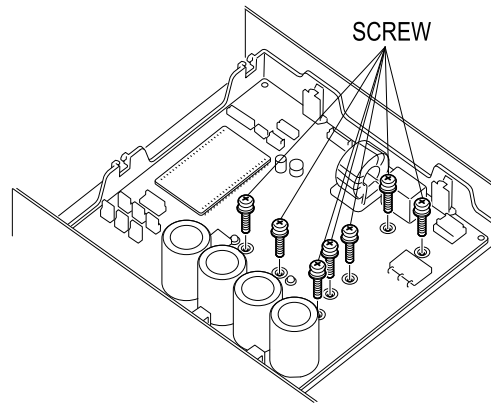

- (3) Take out the board by lift up in arrow direction after release the hook that hold the board in its place.

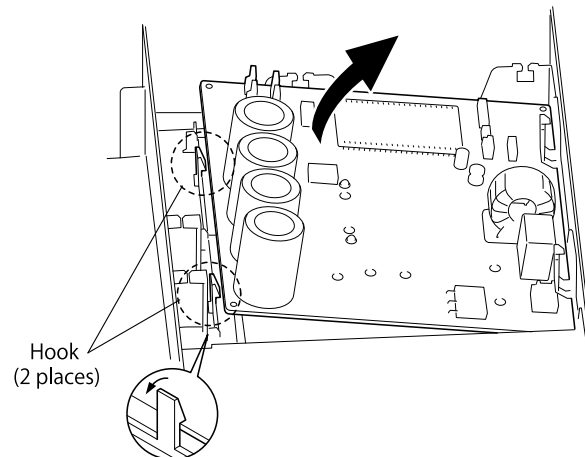

3. Dismantel procedure of main board

- (1) Un-insert connector (14 places), TAB terminal (5 places) and un-screw 1 piece earth screw.

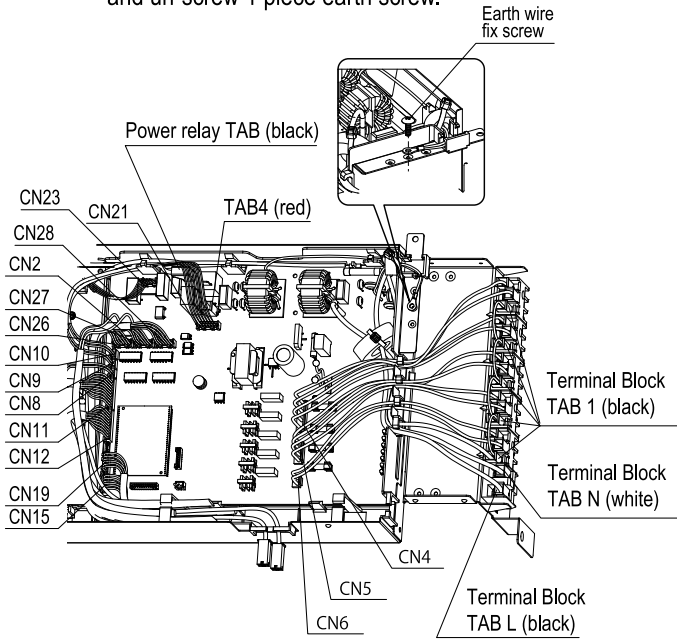

- (1) Release the hooks (3 places) that locking the board and by holding the cord clip lift up in arrow direction the board to take it out.

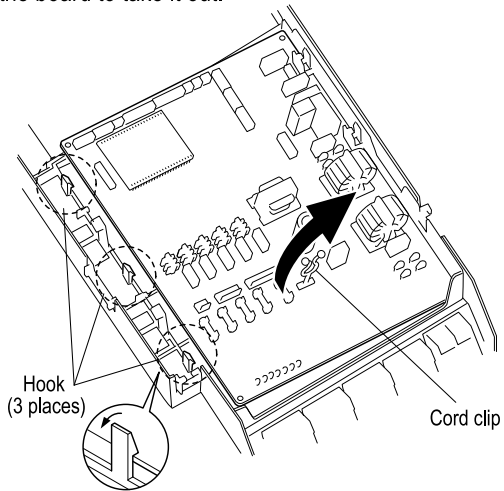

4. Assembly procedure of inverter board

- (1) Preparation before insert back the board.

- (i) Applied uniformly with small amount to 6 places of electronic part at back side of board.

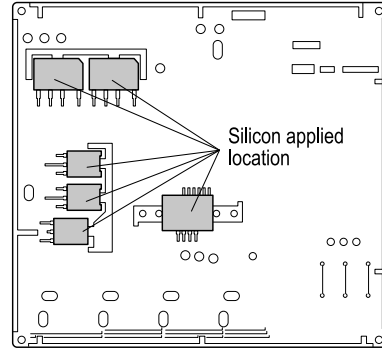

- (ii) Attach the silicon rubber to the IPM body. Arrange so that the holes of silicon rubber and the holes of IPM are concentric.

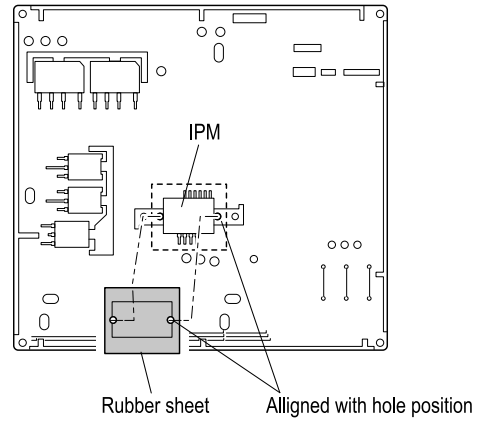

- (2) Insert the board into the pcb support and fix it with hooks (2 places).

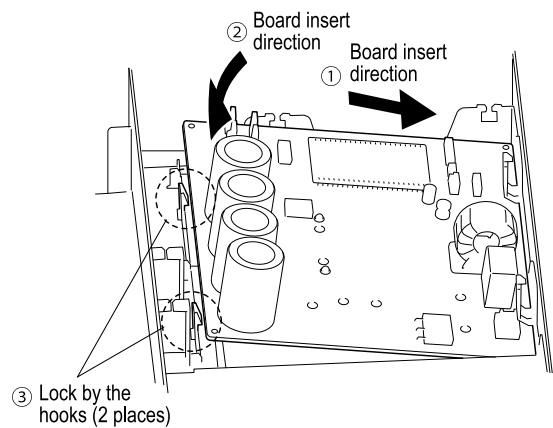

(3) Arrange the board position so that hole for fixing screw and holes at heat sink are concentric.

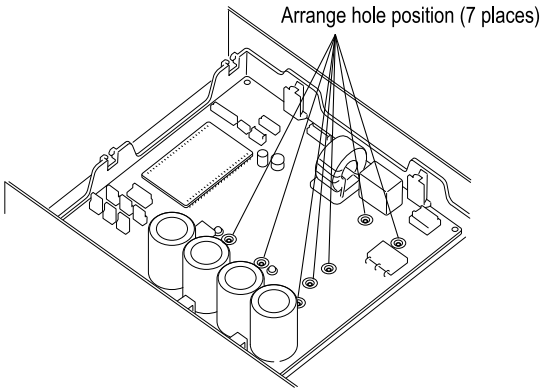

(3) Fix the board with screw (7 places).

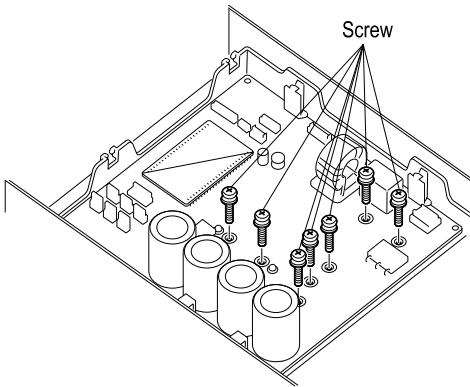

(3) Insert back connector (4 places) and TAB terminal (4 places) at it original location.

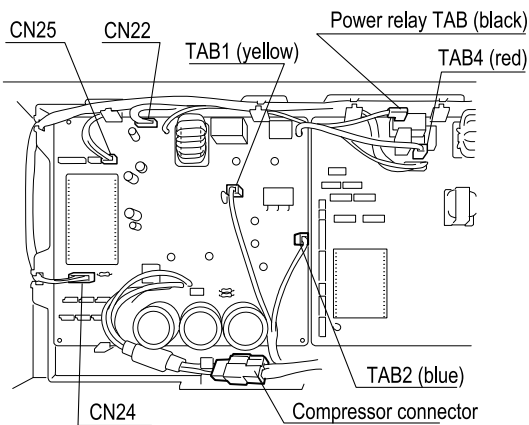

5. Assembly procedure of main board

(1) Insert back the board into pcb support and lock it with hook (3 places).

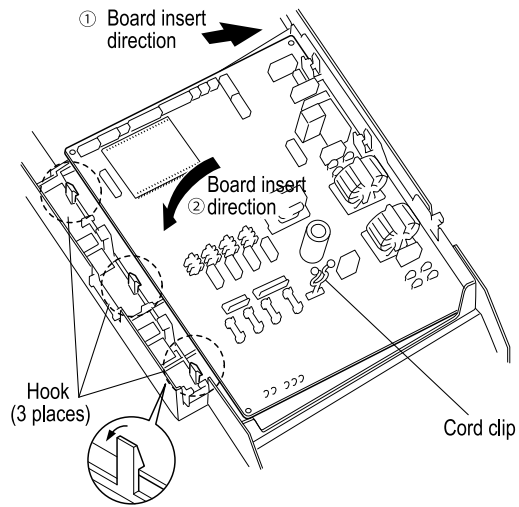

(2) Insert back the connectors (16 places), TAB terminals (9 places) and 1 piece of earth screw.

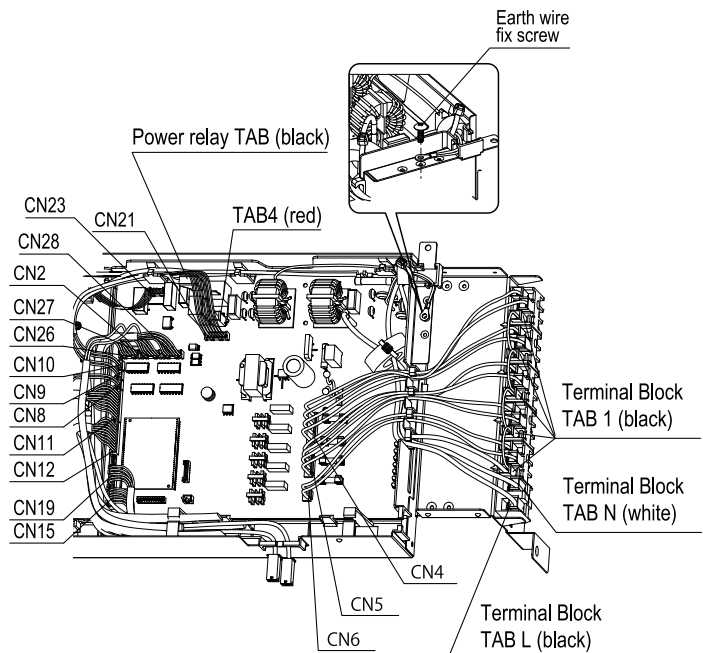

PARTS LIST AND DIAGRAM

OUTDOOR UNIT

MODEL : RAM-90NP5B

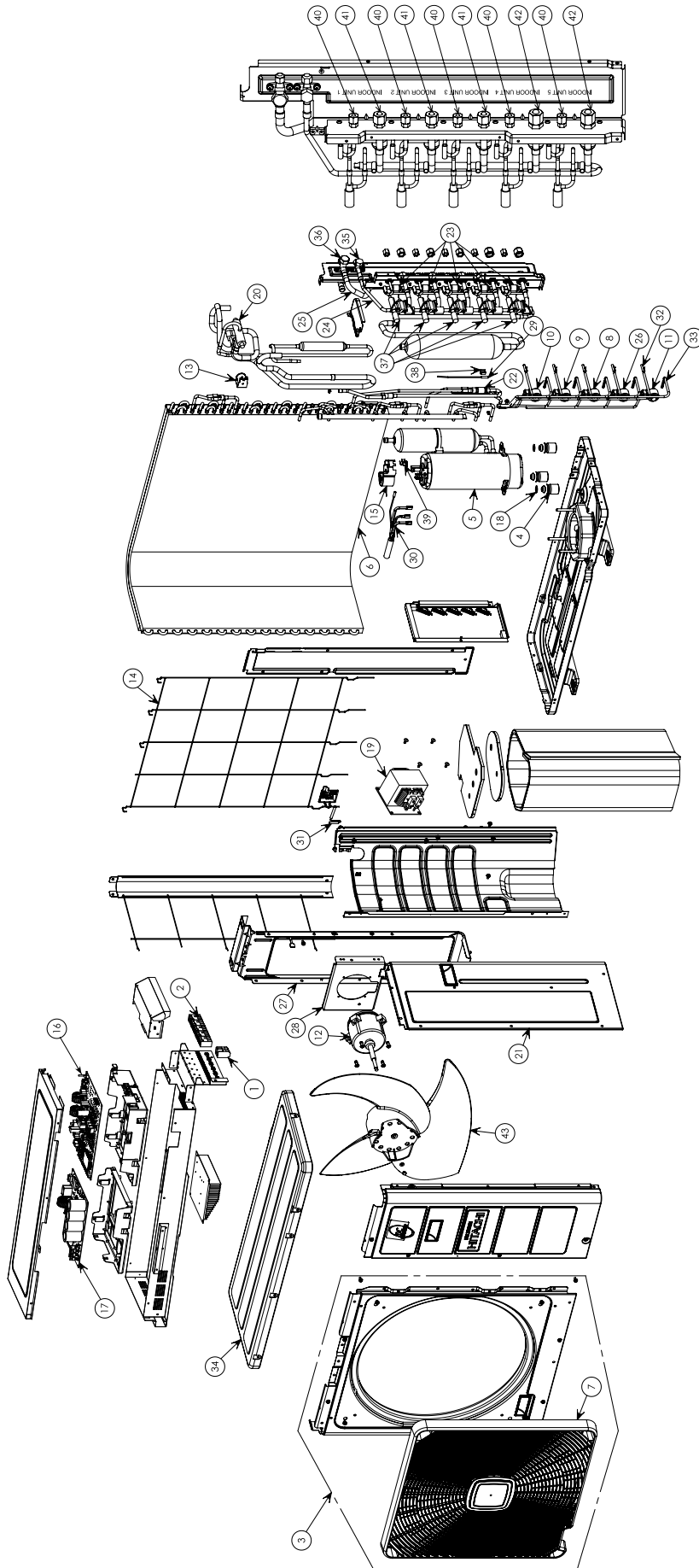

MODEL RAM-90NP5B

NO.	PART NO. RAM-90NP5B	Q'TY / UNIT	PARTS NAME
1	PMRAC-63CA1 S02	1	2P TERMINAL
2	PMRAC-VX13CET S04	5	3P TERMINAL
3	PMRAM-90NP5A S02	1	CABINET
4	RAC-2226HV 805	3	COMPRESSOR RUBBER
5	PMRAM-90NP5B S15	1	COMPRESSOR
6	PMRAM-90QH5 904	1	CONDENSER
7	PMRAM-90QH5 905	1	D-GRILL
8	PMRAM-90NP5B S05	1	EXPANSION VALVE COIL (B)
9	PMRAM-90NP5B S04	1	EXPANSION VALVE COIL (R)
10	PMRAM-90NP5B S03	1	EXPANSION VALVE COIL (W)
11	PMRAM-90NP5B S06	1	EXPANSION VALVE COIL (BC)
12	PMRAM-90NP5B S08	1	FAN MOTOR
13	PMRAM-90NP5B S09	1	MG-COIL (REVERSING VALVE)
14	PMRAC-70YHA S06	1	NET
15	PMRAC-25NH4 910	1	OLR COVER
16	PMRAM-90NP5B S01	1	P.W.B (MAIN)
17	PMRAM-90NP5B S02	1	P.W.B (INVERTER)
18	KPNT1 001	3	PUSH NUT
19	PMRAC-X18CD S04	1	REACTOR
20	PMRAC-S18CPA S02	1	REVERSING VALVE
21	PMRAM-90QH5 914	1	SIDE PLATE R
22	PMRAM-90QH5 915	1	STRAINER (CO-PIPE-AS 1)
23	PMRAM-90QH5 916	1	STRAINER (ST-PIPE-AS)
24	PMRAM-90QH5 917	1	3S PIPE-AS
25	PMRAM-90QH5 918	1	5S PIPE-AS
26	PMRAM-90NP5B S07	1	EXPANSION VALVE COIL Y
27	PMRAM-90QH5 919	1	SUPPORT (FAN MOTOR)
28	PMRAM-90QH5 920	1	FAN MOTOR BRACKET
29	PMRAM-90NP5B S10	1	THERMISTOR (DEFROST)

NO.	PART NO. RAM-90NP5B	Q'TY / UNIT	PARTS NAME
30	PMRAC-80YHA S14	1	THERMISTOR (OH)
31	PMRAM-90NP5B S11	1	THERMISTOR (OUTSIDE TEMPERATURE)
32	PMRAM-90NP5B S12	1	THERMISTOR-PIPE (W)
33	PMRAM-90NP5B S13	1	THERMISTOR-PIPE (N)
34	PMRAM-90QH5 926	1	TOP COVER
35	PMRAM-90QH5 927	1	VALVE (3S)
36	PMRAM-90QH5 928	1	VALVE (5S)
37	PMRAM-90NP5B S14	5	EXPANSION VALVE
38	PMRAM-65QH4 S07	1	SUPPORT (DEF-THERMISTOR)
39	PMRAC-25NH4 S09	1	SUPPORT (OH-THERMISTOR)
40	PMRAM-90QH5 S33	5	2 UNION
41	PMRAM-90QH5 S34	3	3 UNION
42	PMRAM-90QH5 S35	2	4 UNION
43	PMRAM-90NP5A S03	1	PROPELLER FAN

HITACHI

RAM-90NP5B

PM NO. 0586E

Printed in Malaysia