

TECHNICAL CATALOGUE

MONO SPLIT

RAK-18PSC
RAK-25PSC
RAK-35PSC



RAC-18WSC
RAC-25WSC
RAC-35WSC



HITACHI

Specifications in this catalogue are subject to change without prior notice in order for HITACHI to bring in the latest innovations to their customers

Whilst every effort is made to ensure that all dimensions and specifications are correct, any printers' error not rectified are outside the control of HITACHI, who cannot be held responsible for the same

CONTENTS

CONTENTS	1
1 SPECIFICATIONS	1-1
1.1. WALL TYPE (RAK-18PSC/25PSC/35PSC)	1-1
1.2. WALL TYPE (RAC-18WSC/25WSC/35WSC)	1-2
2 DIMENSIONAL DATA	2-1
2.1. WALL TYPE: RAK-18PSC/25PSC/35PSC	2-1
2.2. WALL TYPE: RAC-18WSC/25WSC/35WSC	2-2
3 CAPACITIES TABLE	3-1
3.1. CAPACITY CHARACTERISTIC CURVES	3-1
3.1.1. RAK-18PSC/RAC-18WSC	3-1
3.1.2. RAK-25PSC/RAC-25WSC	3-1
3.1.3. RAK-35PSC/RAC-35WSC	3-2
3.2. CORRECTION FACTORS ACCORDING TO PIPING LENGTH	3-3
3.3. CORRECTION FACTORS ACCORDING TO DEFROSTING OPERATION	3-4
4 SOUND DATA	4-1
4.1. RAC-18WSC	4-1
4.2. RAC-25WSC	4-2
4.3. RAC-35WSC	4-3
5 WORKING RANGE	5-1
5.1. POWER SUPPLY	5-1
5.2. WORKING RANGE	5-1
6 ELECTRICAL DATA	6-1
6.1. INDOOR UNIT	6-1
6.2. OUTDOOR UNIT	6-1
7 WIRING DIAGRAM	7-1
7.1. RAK-18PSC, RAK-25PSC, RAK-35PSC	7-1
7.2. RAC-18WSC, RAC-25WSC, RAC-35WSC	7-2
8 REFRIGERANT CYCLE	8-1
8.1. WALL TYPE: RAK-18PSC/25PSC/35PSC / RAC-18WSC/25WSC/35WSC	8-1
9 CONTROL AND FUNCTION	9-1
9.1. WIRELESS REMOTE CONTROL FUNCTION	9-1
9.2. AUTO CHANGEOVER	9-2
9.3. SHIFT VALUE	9-2
9.4. OPERATION LOCK	9-3
9.5. SETTING THE PREVENTION OF MUTUAL INTERFERENCE	9-3
9.6. ERROR CODE INFORMATION	9-4
9.7. ADDITIONAL FUNCTION VIA DIP-SWITCH SETTINGS	9-6
9.7.1. AUTO RESTART FUNCTION	9-6
9.7.2. HEATING/COOLING ONLY MODEL SELECTION	9-6
10 OPTION LIST	10-1
10.1 WIRED REMOTE CONTROL	10-1
10.1.1 SHIFT VALUE	10-1
10.1.2 ERROR CODE INFORMATION	10-2
10.2 H-LINK ADAPTOR	10-5
10.2.1 SAFETY SUMMARY	10-5
10.2.2 INSTALLATION WORK	10-5
10.2.3 ELECTRICAL WIRING	10-6
10.2.4 DIP SWITCH SETTING	10-7
10.2.5 TEST RUN	10-8
10.3 DRY CONTACT APPLICATION (USING DIP SWITCH)	10-9

1 SPECIFICATIONS

1.1. WALL TYPE (RAK-18PSC/25PSC/35PSC)

INDOOR	UNIT	RAK-18PSC	RAK-25PSC	RAK-35PSC
Nominal capacity adjustable		no	no	no
Nominal Cooling capacity (min - max)	kW	1.8 (0.5 - 2.8)	2.5 (0.5 - 3.4)	3.5 (0.5 - 4.1)
Cooling sensible capacity	kW	1.8	2.2	2.7
Nominal Heating capacity (min - max)	kW	2.3(0.6 -4.8)	3.2(0.6 -5.8)	4.0(0.6 - 6.6)
Noise level cooling (sound pressure) (SL / L / M / H)	dB(A)	22/28/34/40	22/28/34/42	23/28/34/44
Noise level heating (sound pressure) (SL / L / M / H)	dB(A)	22/30/34/41	22/30/34/42	23/30/34/44
Noise level (sound power)	dB(A)	54	56	58
Air flow cooling mode (SL / L / M / H)	m ³ /h	260/300/420/ 470	260/320/420/510	270/320/420/520
Air flow heating mode (SL / L / M / H)	m ³ /h	260/300/420/540	260/370/520/600	270/410/520/610
Fan Motor	W	30	30	30
Dehumidification	l/h	1.2	1.4	1.6
Dimensions (H x W x D)	mm	295x798x258	295x798x258	295x798x258
Weight	kg	12	12	12
Colour		White (N9.5)	White (N9.5)	White (N9.5)
Condensate Drain	mm	φ16mm	φ16mm	φ16mm
Running current (C/H)	A	0.30-3.83/0.28-7.04	0.30-4.17/0.28-9.78	0.30-5.87/0.28-10.65
Power supply		220-230V	220-230V	220-230V
Cable section (Interconnection)	mm ²	1.50x 3+EARTH/-	1.50x 3+EARTH/-	1.50x 3+EARTH/-
Piping diameter (Liq / Gas)	Inch	1/4" / 1/2"	1/4" / 1/2"	1/4" / 1/2"
Drain diameter (ext)	mm	φ16	φ16	φ16
Remote control (standard/optional) *		RAR-5W2/SPX-RCDB	RAR-5W2/SPX-RCDB	RAR-5W2/SPX-RCDB
Filter				
Pre-filter (Standard/Optional)		Micro Mesh Stainless/-	Micro Mesh Stainless/-	Micro Mesh Stainless/-

NOTE:

1. The nominal cooling and heating capacity is the combined capacity of the HITACHI standard split system, and are based on the ISO 5151.

Operation Conditions		Cooling	Heating
Indoor Air Inlet Temperature	dB	27.0 °C	20.0 °C
	WB	19.0 °C	15.0 °C
Outdoor Air Inlet Temperature	dB	35.0 °C	7.0 °C
	WB	24.0 °C	6.0 °C
Piping Length: 5.0 meters; Piping Lift: 0 meter dB: Dry Bulb; WB: Wet Bulb			

2. The Sound Pressure Level is based on the following conditions:

- 0.8 meter beneath indoor height center
- 1 meter from Discharge grille

The above data was measured in an anechoic chamber. Please take into consideration reflected sound of your specific site

1.2. WALL TYPE (RAC-18WSC/25WSC/35WSC)

OUTDOOR	UNIT	RAC-18WSC	RAC-25WSC	RAC-35WSC	
Nominal Cooling capacity (min - max)	kW	1.8 (0.5 - 2.8)	2.5 (0.5 - 3.4)	3.5 (0.5 - 4.1)	
Nominal Heating capacity (min - max)	kW	2.3(0.6 -4.8)	3.2(0.6 -5.8)	4.0(0.6 - 6.6)	
Nominal cooling power input (min - max)	kW	0.300 (0.070-0.880)	0.470 (0.070-0.960)	0.805 (0.070-1.350)	
Nominal heating power input (min - max)	kW	0.375 (0.065-1.620)	0.570 (0.065-2.250)	0.790 (0.065-2.450)	
EER / COP		6.00/6.13	5.32/5.61	4.35/5.06	
SEER / SCOP		7.41/4.60	8.50/4.68	8.50/4.72	
Energy class (SEER/SCOP)		A++/A++	A+++/A++	A+++/A++	
Noise level cooling (sound pressure)	dB(A)	46	48	49	
Noise level heating (sound pressure)	dB(A)	46	48	49	
Noise level (sound power)	dB(A)	60	62	63	
Air flow (Cooling / Heating)	m ³ /h	1860 / 1620	1860 / 1620	1920 / 1620	
Dimensions (H x W x D)	mm	600x792x299	600x792x299	600x792x299	
Weight	kg	40	40	40	
Colour		Beige (5Y7/2)	Beige (5Y7/2)	Beige (5Y7/2)	
Power supply		230V / 1Ph / 50Hz	230V / 1Ph / 50Hz	230V / 1Ph / 50Hz	
Recommended fuse size	A	25	25	25	
Starting current (C/H)	A	2.32/2.42	3.37/3.53	4.67/4.88	
Running current (C/H)	A	0.30-3.83/0.28-7.04	0.30-4.17/0.28-9.78	0.30-5.87/0.28-10.65	
Cable section (Power)	mm ²	1.50x 2+EARTH	1.50x 2+EARTH	1.50x 2+EARTH	
Cable section (Interconnection)	mm ²	1.50x 3+EARTH	1.50x 3+EARTH	1.50x 3+EARTH	
Piping diameter (Liq / Gas)		1/4" / 1/2"	1/4" / 1/2"	1/4" / 1/2"	
Minimum piping length	m	3	3	3	
Maximum piping length / height difference	m	20 / 10	20 / 10	20 / 10	
Current quantity of refrigerant / Chargeless	kg	1.35	1.35	1.35	
Chargeless / Additional refrigerant charge	m / g/m	20/-	20/-	20/-	
Working range (cooling / heating)	°C	-10~43/-20~21	-10~43/-20~21	-10~43/-20~21	
Refrigerant		R410A	R410A	R410A	
Condenser Fan		Propeller Fan	Propeller Fan	Propeller Fan	
Compressor	Type	SCROLL	SCROLL	SCROLL	SCROLL
	Oil Charge	380	380	380	380
	Oil Type	poe	poe	poe	poe
	Coil Resistance	2.23 at 20°C	2.23 at 20°C	2.23 at 20°C	2.23 at 20°C
	Quantity	1	1	1	1

NOTE:

1. The Sound Pressure Level is based on the following conditions:

- 1 meter from the unit front surface and 1 meter from floor level

The above data was measured in an anechoic chamber. Please take into consideration reflected sound of your specific site

2 DIMENSIONAL DATA

2.1. WALL TYPE: RAK-18PSC/25PSC/35PSC

UNIT:mm

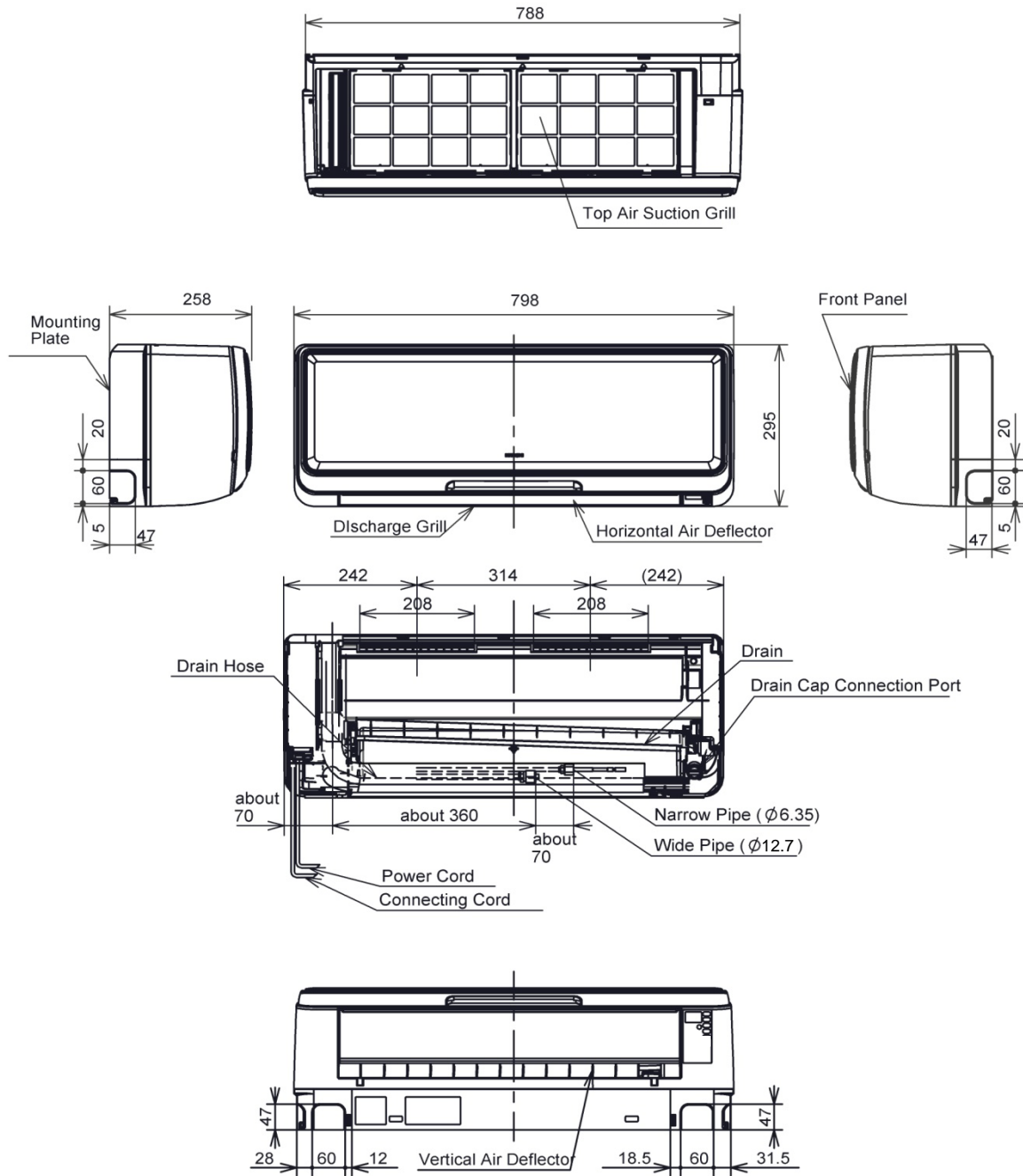

3 CAPACITIES TABLE

3.1. CAPACITY CHARACTERISTIC CURVES

The following charts show the characteristics of outdoor unit capacity, which corresponds with the operating ambient temperature of outdoor unit.

Condition:

①Pipe length / height difference : 5m / 0m

③Capacity loss due to white frost and defrost operation is not included.

②Indoor fan speed at High mode

3.1.1. RAK-18PSC/RAC-18WSC

COOLING [50Hz, 230V]

INDOOR		OUTDOOR TEMPERATURE (°CDB)																				
EWB	EDB	-10			21			27			32			35			40			43		
°C	°C	TC	SHC	PI	TC	SHC	PI	TC	SHC	PI	TC	SHC	PI	TC	SHC	PI	TC	SHC	PI	TC	SHC	PI
12.0	18	2636	2416	315	1692	1825	212	1566	1685	250	1476	1597	276	1422	1527	288	1332	1439	309	1278	1369	321
14.0	20	2636	2416	315	1818	1825	212	1692	1702	253	1584	1597	279	1530	1544	291	1422	1439	312	1368	1386	327
16.0	22	2636	2571	320	1944	1825	215	1800	1702	256	1692	1597	282	1638	1544	297	1530	1439	318	1476	1386	330
18.0	25	2827	2756	325	2070	1983	218	1908	1843	259	1800	1737	285	1728	1667	297	1620	1562	321	1548	1492	333
19.0	27	2922	2849	330	2142	2088	220	1980	1931	262	1872	1825	288	1800	1755	300	1692	1650	321	1620	1580	333
22.0	30	3240	2818	330	2376	2071	220	2196	1913	262	2070	1808	291	1998	1737	303	1800	1685	333	1674	1650	351
24.0	32	3462	2818	335	2538	2071	223	2340	1913	265	2214	1808	291	2124	1737	306	1872	1720	342	1710	1702	363

HEATING [50Hz, 230V]

INDOOR		OUTDOOR TEMPERATURE (°CDB)																							
	EDB	-15			-10			-7			-5			0			7			10			15		
	°C	TC	SHC	PI	TC	SHC	PI	TC	SHC	PI	TC	SHC	PI	TC	SHC	PI	TC	SHC	PI	TC	SHC	PI			
	16	2357	0	1081	2687	0	1151	2901	0	1204	3043	0	1239	3396	0	1302	2325	0	346	2537	0	356	2928	0	373
	18	2334	0	1070	2664	0	1135	2874	0	1179	3013	0	1208	3360	0	1271	2314	0	364	2528	0	371	2916	0	391
	20	2300	0	1055	2640	0	1120	2848	0	1159	2987	0	1185	3332	0	1250	2300	0	375	2473	0	388	2898	0	409
	22	2269	0	1117	2618	0	1108	2813	0	1137	2944	0	1156	3296	0	1250	2286	0	390	2500	0	402	2884	0	426
	24	2234	0	1026	2593	0	1094	2787	0	1115	2917	0	1128	3268	0	1190	2272	0	405	2486	0	418	2843	0	443

3.1.2. RAK-25PSC/RAC-25WSC

COOLING [50Hz, 230V]

INDOOR		OUTDOOR TEMPERATURE (°CDB)																				
EWB	EDB	-10			21			27			32			35			40			43		
°C	°C	TC	SHC	PI	TC	SHC	PI	TC	SHC	PI	TC	SHC	PI	TC	SHC	PI	TC	SHC	PI	TC	SHC	PI
12.0	18	2964	2410	400	2350	2250	332	2175	2076	392	2050	1968	432	1975	1882	451	1850	1774	484	1775	1687	503
14.0	20	2964	2410	400	2525	2250	332	2350	2098	396	2200	1968	437	2125	1903	456	1975	1774	489	1900	1709	512
16.0	22	2964	2565	406	2700	2250	337	2500	2098	401	2350	1968	442	2275	1903	465	2125	1774	498	2050	1709	517
18.0	25	3179	2750	412	2875	2444	341	2650	2271	405	2500	2141	447	2400	2055	465	2250	1925	503	2150	1839	522
19.0	27	3286	2843	418	2975	2574	345	2750	2379	410	2600	2250	451	2500	2163	470	2350	2033	503	2250	1947	522
22.0	30	3643	2812	418	3300	2552	345	3050	2358	410	2875	2228	456	2775	2141	475	2500	2076	522	2325	2033	550
24.0	32	3893	2812	425	3525	2552	350	3250	2358	415	3075	2228	456	2950	2141	479	2600	2120	536	2375	2098	569

EWB : Evaporator Wet Bulb temperature (°C)

EDB : Evaporator Dry Bulb temperature (°C)

(°CDB) : Outdoor Unit Inlet Air Dry Temperature (°C)

TC : Total Capacity (W)

SHC : Sensible Heating Capacity (W)

PI : Power Input

HEATING [50Hz, 230V]

INDOOR		OUTDOOR TEMPERATURE (°CDB)																							
		-15			-10			-7			-5			0			7			10			15		
°C	EDB	TC	SHC	PI	TC	SHC	PI	TC	SHC	PI	TC	SHC	PI	TC	SHC	PI	TC	SHC	PI	TC	SHC	PI	TC	SHC	PI
16		3279	0	1505	3556	0	1591	3738	0	1658	3859	0	1703	4160	0	1779	3235	0	526	3530	0	540	4074	0	567
18		3247	0	1489	3526	0	1569	3703	0	1624	3821	0	1661	4116	0	1738	3219	0	553	3517	0	564	4058	0	594
20		3200	0	1468	3494	0	1548	3670	0	1597	3788	0	1629	4082	0	1709	3200	0	570	3440	0	590	4032	0	621
22		3157	0	1555	3464	0	1532	3626	0	1566	3734	0	1589	4038	0	1709	3181	0	593	3478	0	612	4013	0	647
24		3108	0	1428	3432	0	1512	3592	0	1535	3699	0	1551	4004	0	1627	3162	0	616	3459	0	635	3955	0	673

3.1.3. RAK-35PSC/RAC-35WSC

COOLING [50Hz, 230V]

INDOOR		OUTDOOR TEMPERATURE (°CDB)																							
		-10			21			27			32			35			40			43					
°C	EDB	TC	SHC	PI	TC	SHC	PI	TC	SHC	PI	TC	SHC	PI	TC	SHC	PI	TC	SHC	PI	TC	SHC	PI	TC	SHC	PI
12.0	18	2954	2142	487	3011	2570	521	2787	2372	614	2870	2457	741	2765	2349	773	2590	2214	829	2485	2106	861			
14.0	20	2954	2142	487	3235	2570	521	3011	2397	621	3080	2457	749	2975	2376	781	2765	2214	837	2660	2133	877			
16.0	22	2954	2279	495	3460	2570	528	3203	2397	628	3290	2457	757	3185	2376	797	2975	2214	853	2870	2133	886			
18.0	25	3168	2444	502	3684	2792	534	3396	2595	635	3500	2673	765	3360	2565	797	3150	2403	861	3010	2295	894			
19.0	27	3275	2526	510	3812	2941	541	3524	2718	643	3640	2808	773	3500	2700	805	3290	2538	861	3150	2430	894			
22.0	30	3631	2499	510	4228	2916	541	3908	2694	643	4025	2781	781	3885	2673	813	3500	2592	894	3255	2538	942			
24.0	32	3880	2499	518	4517	2916	548	4164	2694	650	4305	2781	781	4130	2673	821	3640	2646	918	3325	2619	974			

HEATING [50Hz, 230V]

INDOOR		OUTDOOR TEMPERATURE (°CDB)																							
		-15			-10			-7			-5			0			7			10			15		
°C	EDB	TC	SHC	PI	TC	SHC	PI	TC	SHC	PI	TC	SHC	PI	TC	SHC	PI	TC	SHC	PI	TC	SHC	PI	TC	SHC	PI
16		3689	0	1609	4017	0	1716	4231	0	1766	4375	0	1799	4730	0	1864	4044	0	729	4412	0	749	5092	0	786
18		3653	0	1592	3983	0	1693	4192	0	1729	4332	0	1753	4680	0	1820	4024	0	766	4396	0	782	5072	0	823
20		3600	0	1570	3947	0	1670	4155	0	1700	4294	0	1720	4641	0	1790	4000	0	790	4300	0	818	5040	0	861
22		3551	0	1663	3913	0	1653	4105	0	1668	4232	0	1677	4591	0	1790	3976	0	822	4348	0	848	5016	0	897
24		3497	0	1527	3877	0	1632	4067	0	1635	4193	0	1637	4552	0	1704	3952	0	853	4324	0	880	4944	0	933

EWB : Evaporator Wet Bulb temperature (°C)
 EDB : Evaporator Dry Bulb temperature (°C)
 (°CDB) : Outdoor Unit Inlet Air Dry Temperature (°C)

TC : Total Capacity (W)
 SHC : Sensible Heating Capacity (W)
 PI : Power Input

3.2. CORRECTION FACTORS ACCORDING TO PIPING LENGTH

Correction Factor for **Cooling Capacity** according to Piping Length

The cooling capacity should be corrected according to the following formula:

$$CCA = CC \times F$$

- CCA: Actual Corrected Cooling Capacity (kcal/h)
- CC: Cooling Capacity in the Performance Table (kcal/h)
- F: Correction Factor Based on the Equivalent Piping Length

Correction Factor for **Heating Capacity** according to Piping Length

The heating capacity should be corrected according to the following formula:

$$HCA = HC \times F$$

- HCA: Actual Corrected Heating Capacity (kcal/h)
- HC: Heating Capacity in the Performance Table (kcal/h)
- F: Correction Factor Based on the Equivalent Piping Length

The correction factors are shown in the following figure.

Equivalent Piping Length for:

- One 90° Elbow is 0.5m.
- One 180° Curve is 1.5m.

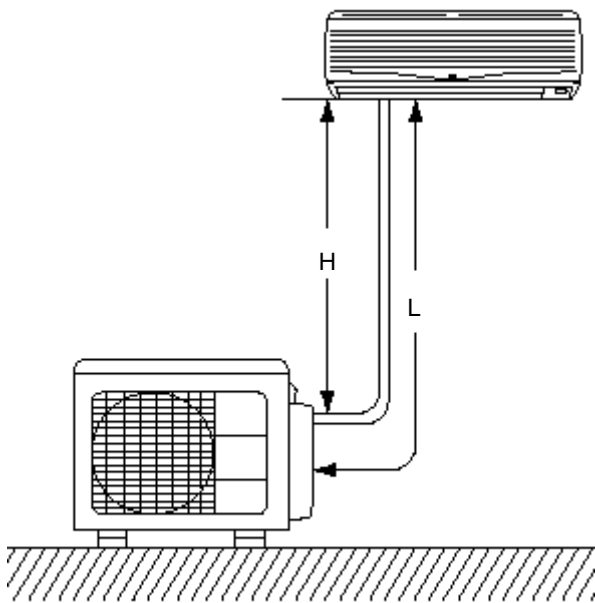

- H: Vertical Distance Between Indoor Unit and Outdoor Units in Meters
- L: Actual One-Way Piping Length Between Indoor Unit and Outdoor Unit in Meters
- EL: Equivalent Total Distance Between Indoor Unit and Outdoor Unit in Meters (Equivalent One-Way Piping Length)

Models : RAK-18PSC/RAC-18WSC, RAK-25PSC/RAC-25WSC, RAK-35PSC/RAC-35WSC

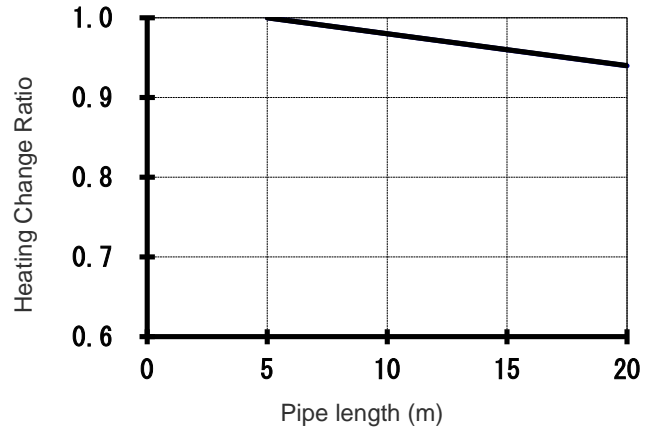
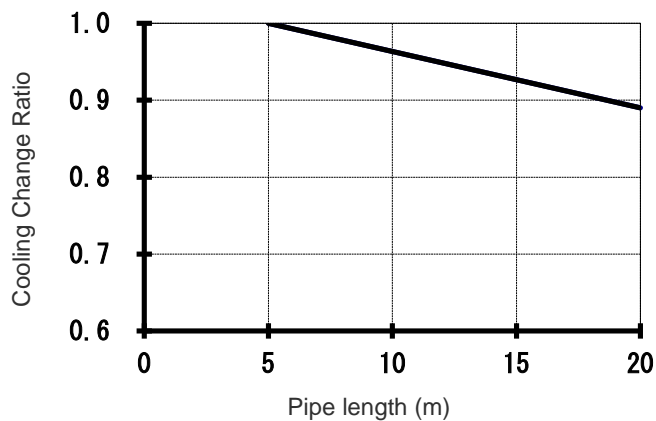

3.3. CORRECTION FACTORS ACCORDING TO DEFROSTING OPERATION

The heating capacity in the preceding paragraph, excludes the condition of the frost or the defrosting operation period. In consideration of the frost or the defrosting operation, the heating capacity is corrected by the equation below.

Corrected heating capacity = Defrost Correction factor x unit capacity

OUTDOOR TEMPERATURE (°CDB)	-15	-10	-5	0	7	10	15
Correction factor (humidity rate 85% RH)	0.95	0.95	0.91	0.81	1.0	1.0	1.0

Correction Factor

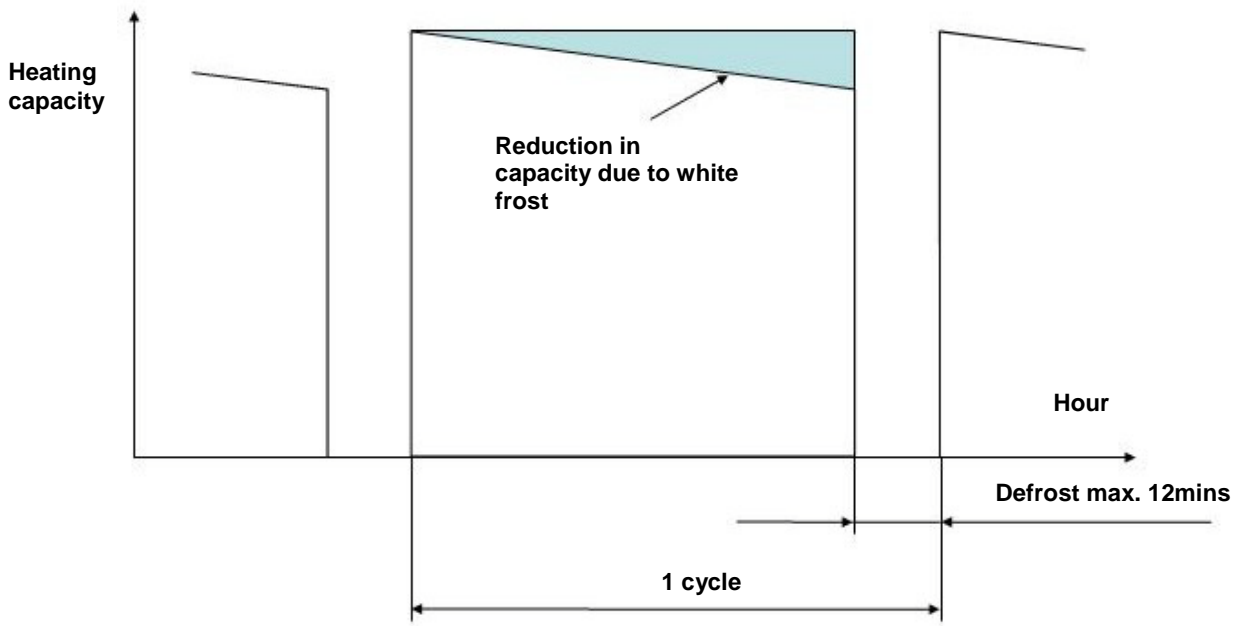

NOTE:

The correction factor is not valid for special conditions such as snowfall or operation in a transitional period.

4 SOUND DATA

4.1. RAC-18WSC

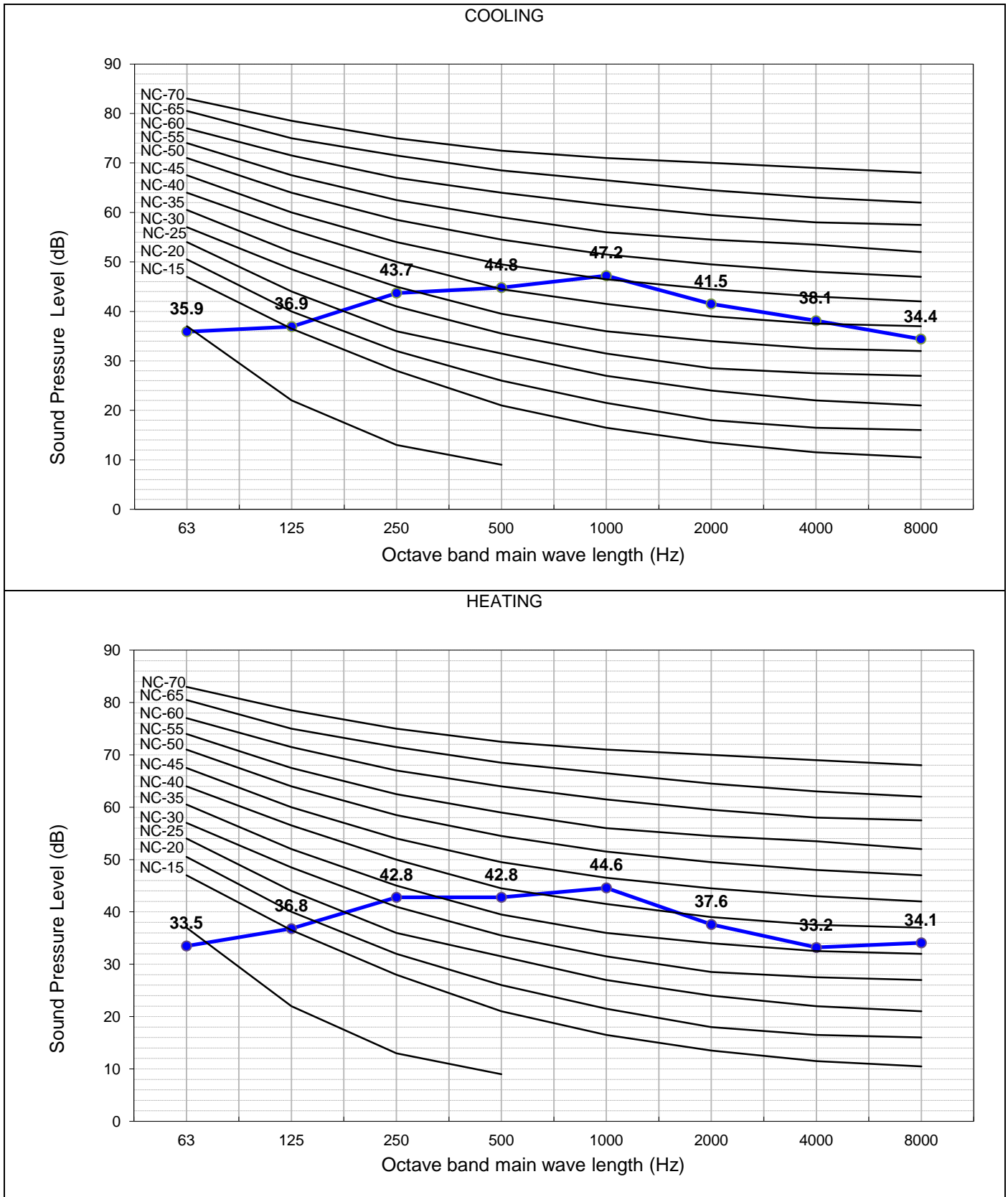

The Sound Pressure Level is based on the following conditions:

1 meter from the unit front surface and 1 meter from floor level

The above data was measured in an anechoic chamber. Please take into consideration reflected sound of your specific site

4.2. RAC-25WSC

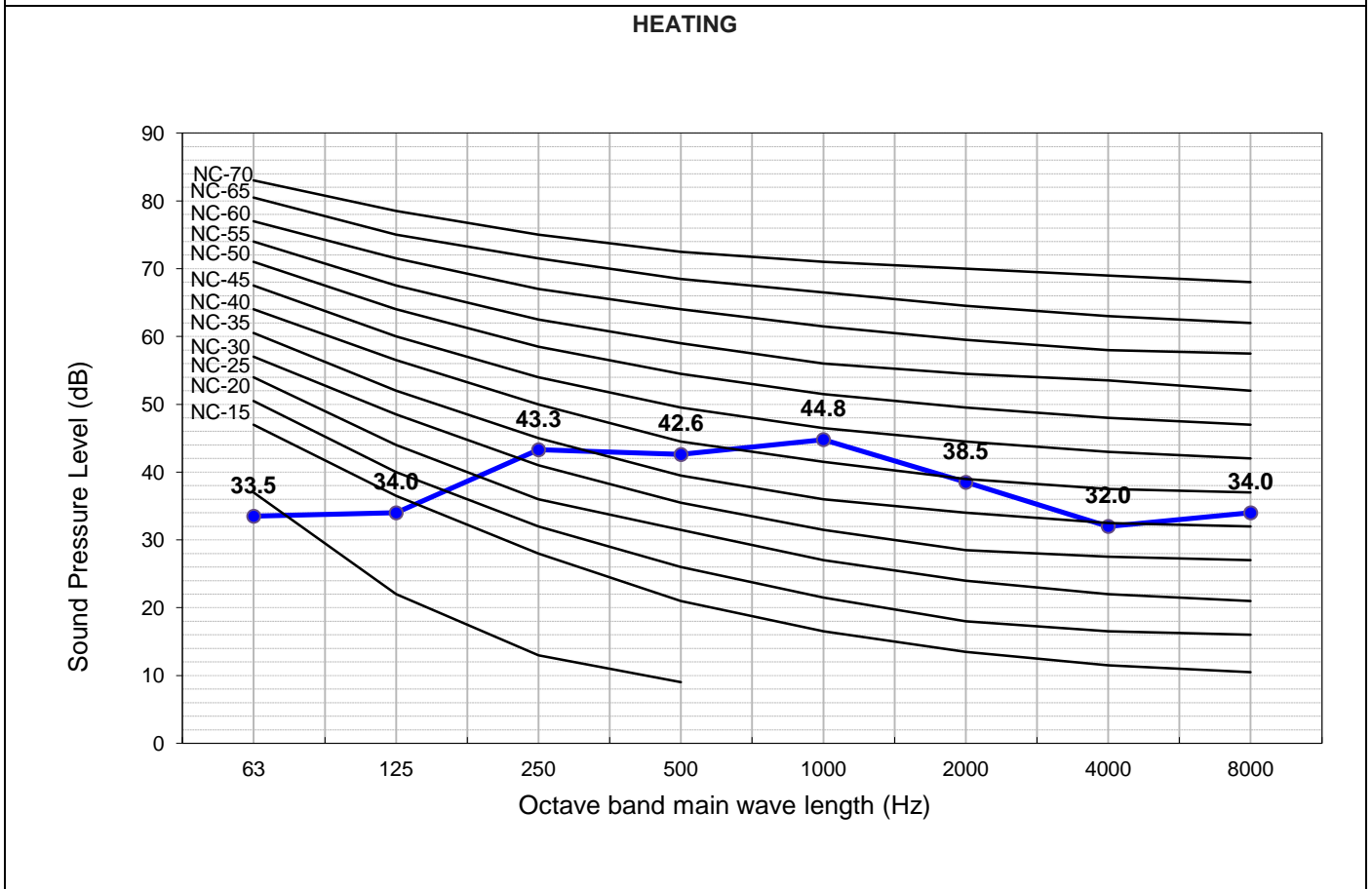
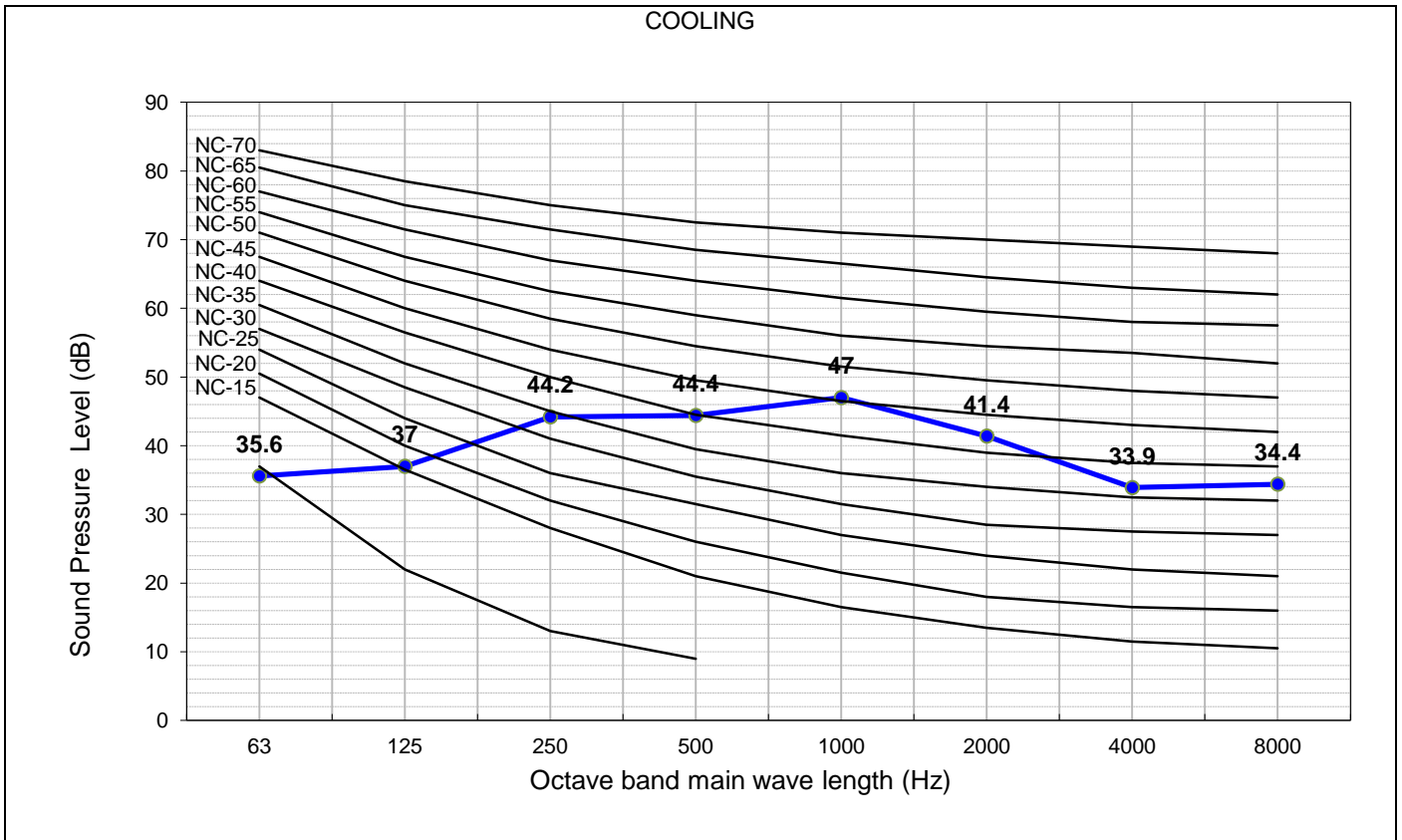

The Sound Pressure Level is based on the following conditions:

1 meter from the unit front surface and 1 meter from floor level

The above data was measured in an anechoic chamber. Please take into consideration reflected sound of your specific site

4.3. RAC-35WSC

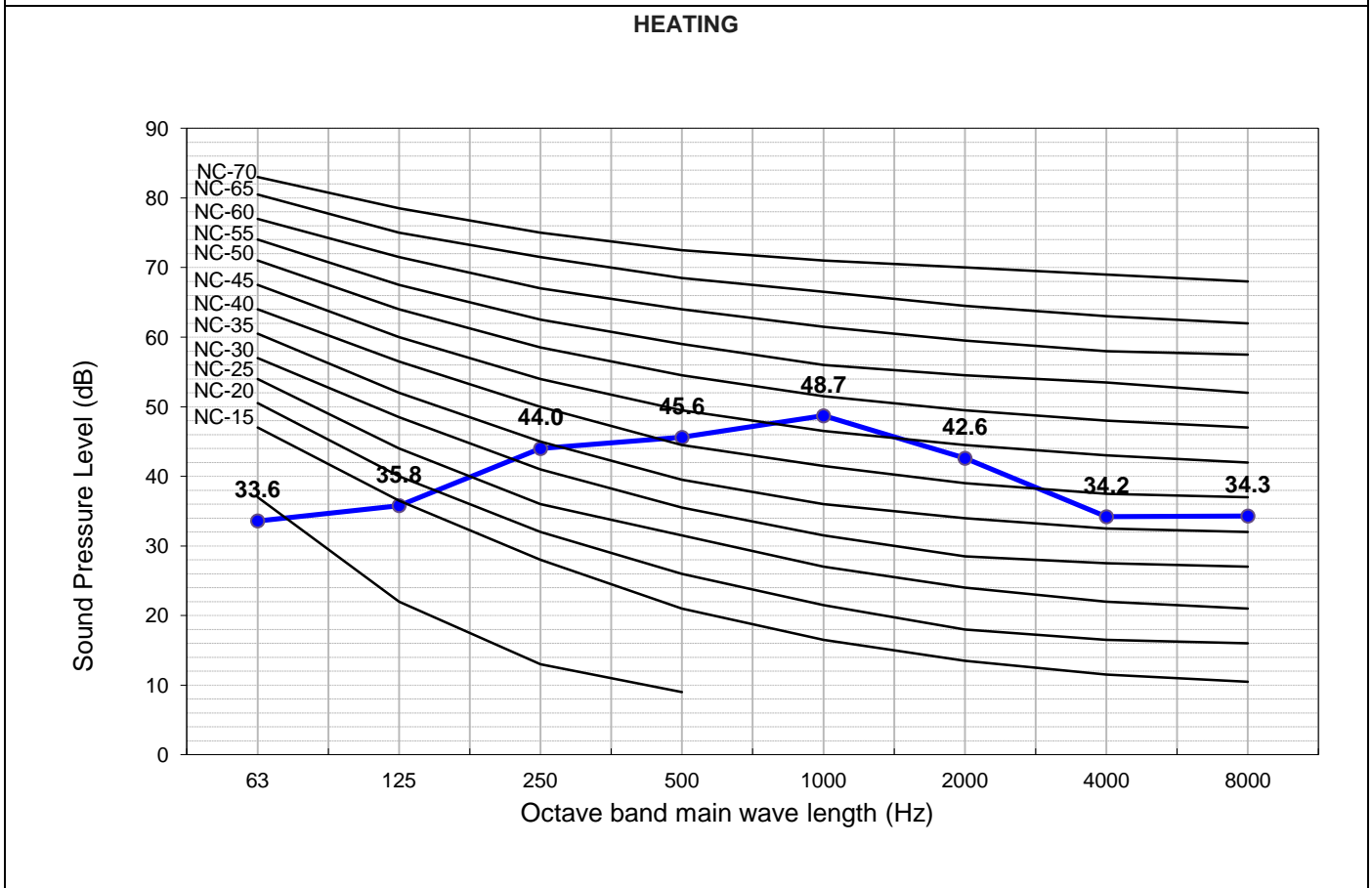
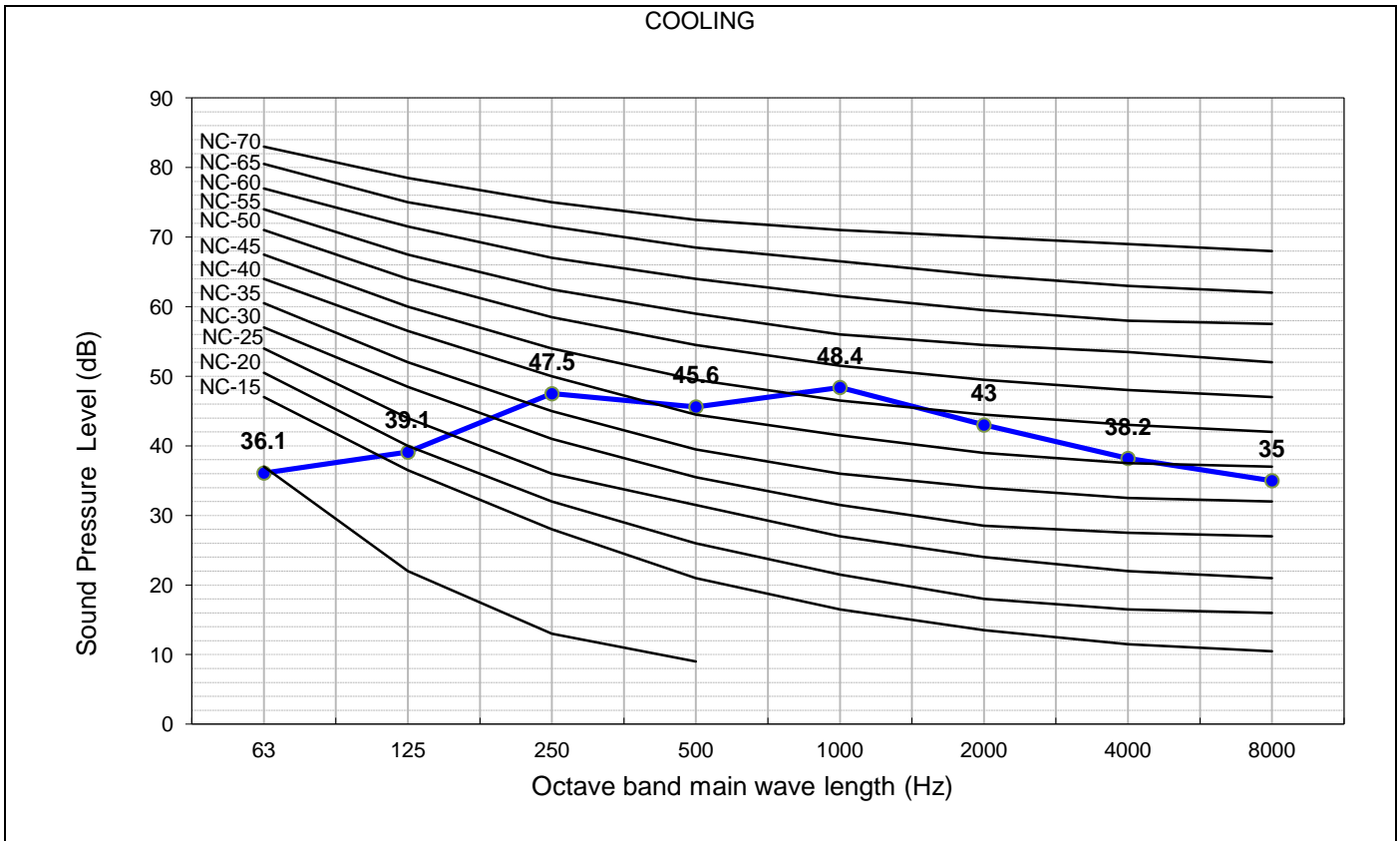

The Sound Pressure Level is based on the following conditions:

1 meter from the unit front surface and 1 meter from floor level

The above data was measured in an anechoic chamber. Please take into consideration reflected sound of your specific site

5 WORKING RANGE

5.1. POWER SUPPLY

Working Voltage	207V ~ 253V
Voltage Imbalance	Within a 3% Deviation from Each Voltage at the Main Terminal of Outdoor Unit
Starting Voltage	Higher than 85% of the Rated Voltage

5.2. WORKING RANGE

Applicable models:

RAC-18WSC
RAC-25WSC
RAC-35WSC

The temperature range is indicated in the following table.

Cooling

working range	min (°C)	max (°C)	rated (°C)
outdoor	-10	43	35
indoor	16	32	27

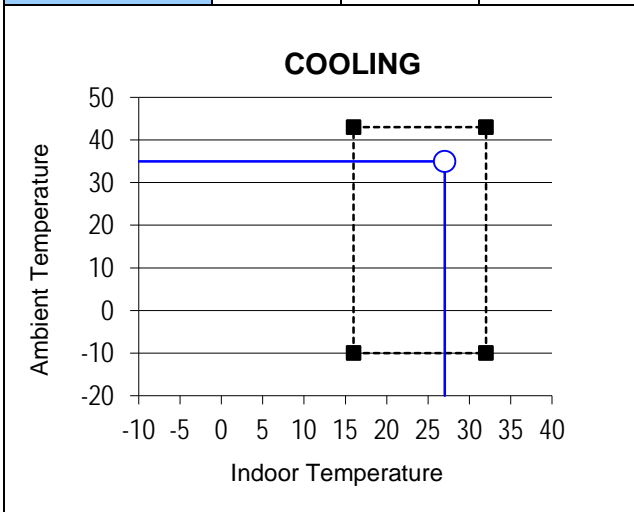

Heating

working range	min (°C)	max (°C)	rated (°C)
outdoor	-20	21	7
indoor	16	32	20

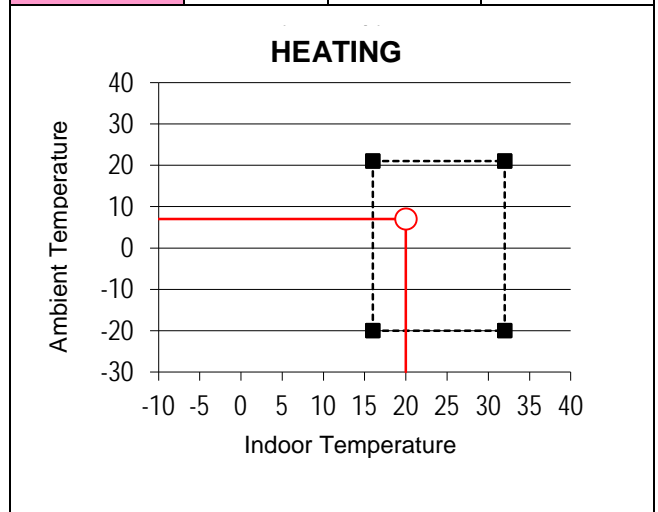

6 ELECTRICAL DATA

6.1. INDOOR UNIT

Model	Unit Main Power		Applicable Current		Indoor Fan Motor	
	VOL, PH, Hz	Fuse Rating (A)	STC	RNC	RNC	IPT
RAK-18PSC	230, 1, 50	3.15	(C) 2.32 (H) 2.42	(C) 7.04 (H) 3.83	0.3	30
RAK-25PSC	230, 1, 50	3.15	(C) 3.37(H) 3.53	(C) 9.78 (H) 4.17	0.3	30
RAK-35PSC	230, 1, 50	3.15	(C)4.67 (H) 4.88	(C) 10.65 (H) 5.87	0.3	30

VOL: Rated Unit Power Supply Voltage (V)

Hz: Frequency (Hz)

STC: Starting Current (A)

RNC: Running Current (A)

PH: Phase (ϕ)

IPT: Input (W)

6.2. OUTDOOR UNIT

Model	Unit Main Power				Compressor Motor					
	VOL, PH, Hz	Fuse Rating (A)	Min (V)	Max (V)	Locked Rotor Ampere (A)	STC	Cooling Operation		Heating Operation	
							RNC	IPT	RNC	IPT
RAC-18WSC	230, 1, 50	25	207	253		2.42	7.04	300	3.83	375
RAC-25WSC	230, 1, 50	25	207	253		3.53	9.78	470	4.17	570
RAC-35WSC	230, 1, 50	25	207	253		4.88	10.65	805	5.87	790

VOL: Rated Unit Power Supply Voltage (V)

HZ: Frequency (Hz)

STC: Starting Current (A)

RNC: Running Current (A)

PH: Phase (ϕ)

IPT: Input (W)

NOTE:

1. The above compressor data is based on 100% capacity combination of indoor units at the rated operating frequency
2. This data is based on the same conditions as the nominal heating and cooling capacities.
3. The compressor started by an inverter, resulting in extremely low starting current.

7 WIRING DIAGRAM

7.1. RAK-18PSC, RAK-25PSC, RAK-35PSC

BLK: BLACK YEL: YELLOW
 BLU: BLUE GRN: GREEN
 RED: RED WHT: WHITE
 GRY: GRAY

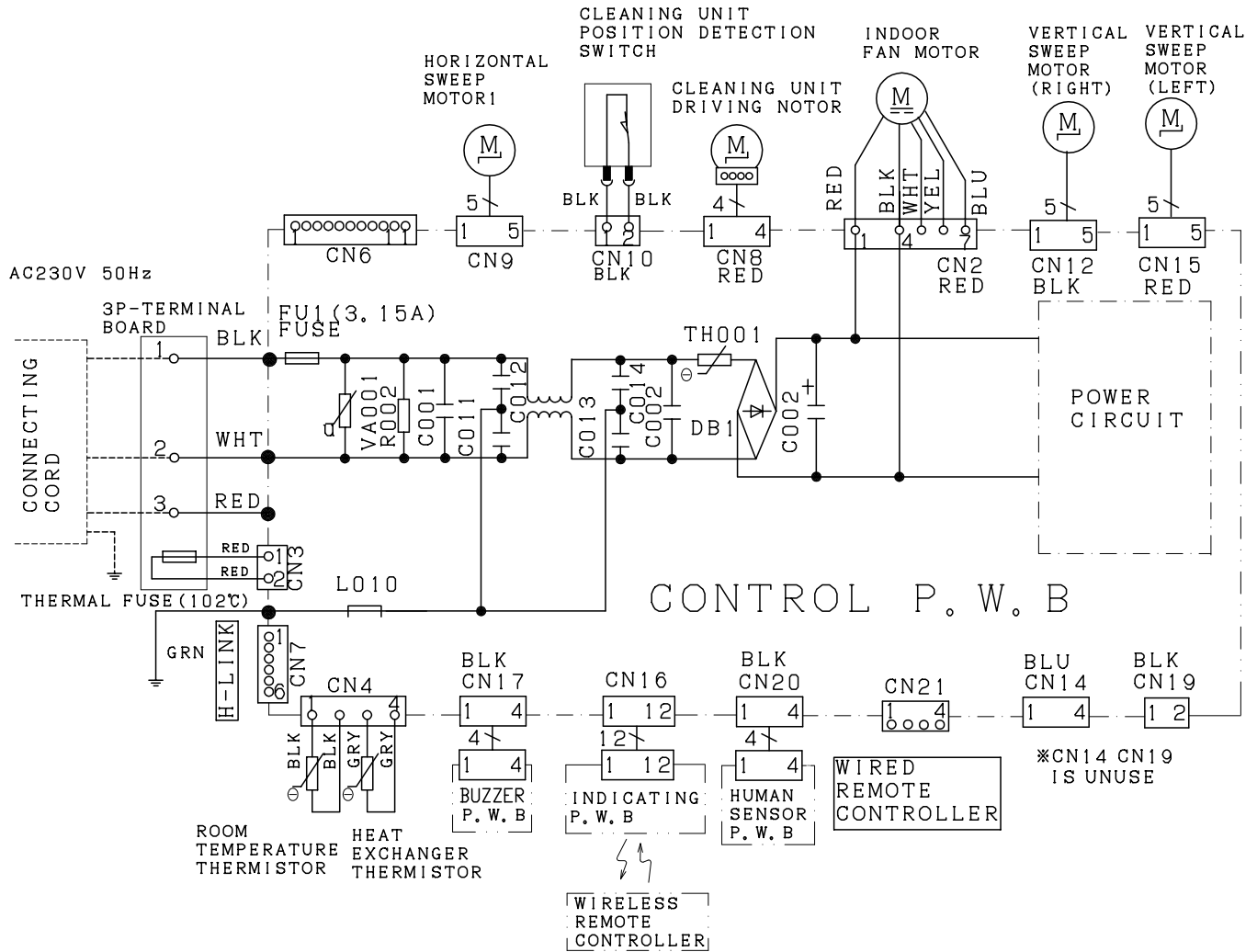

7.2. RAC-18WSC, RAC-25WSC, RAC-35WSC

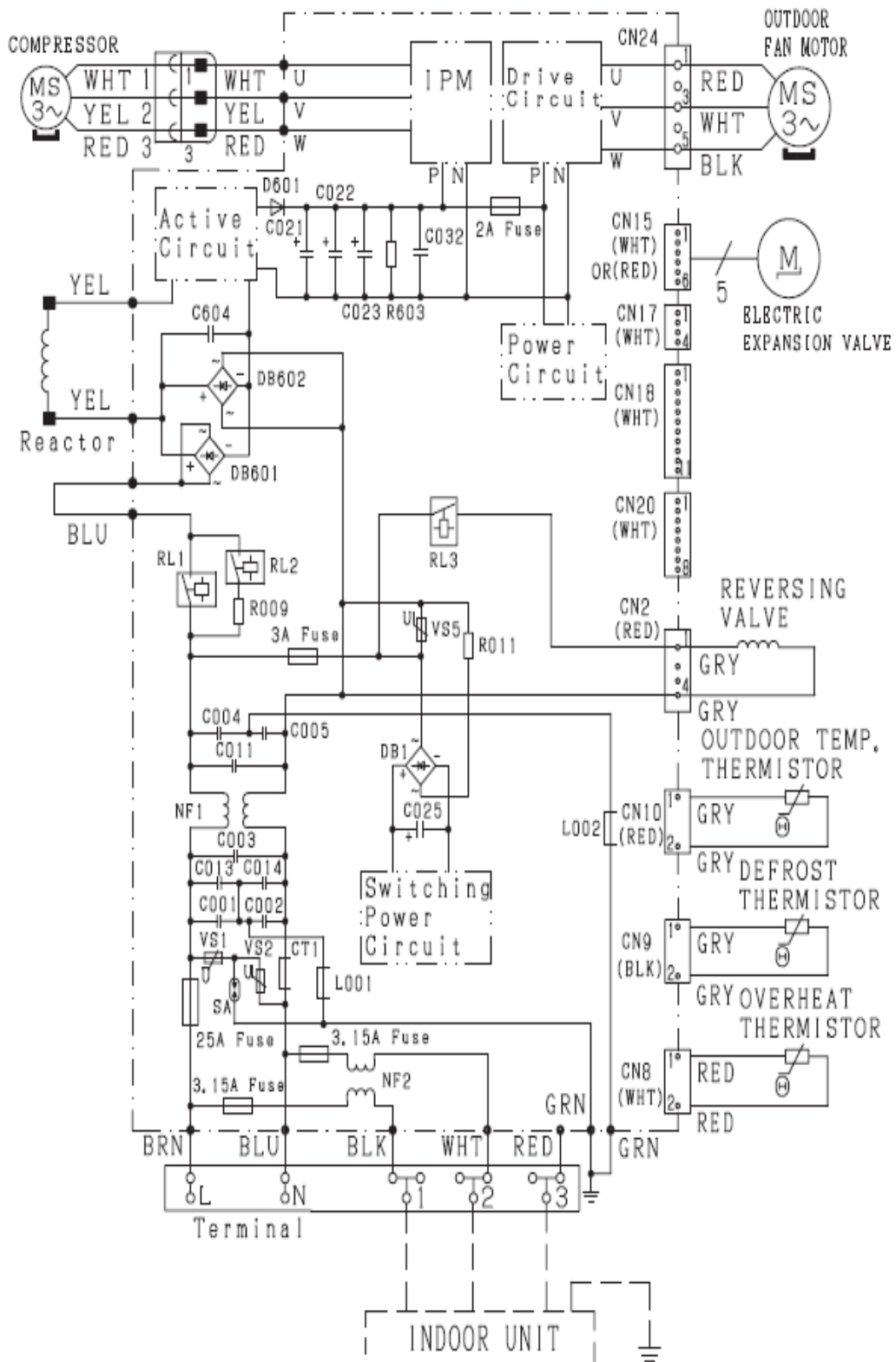





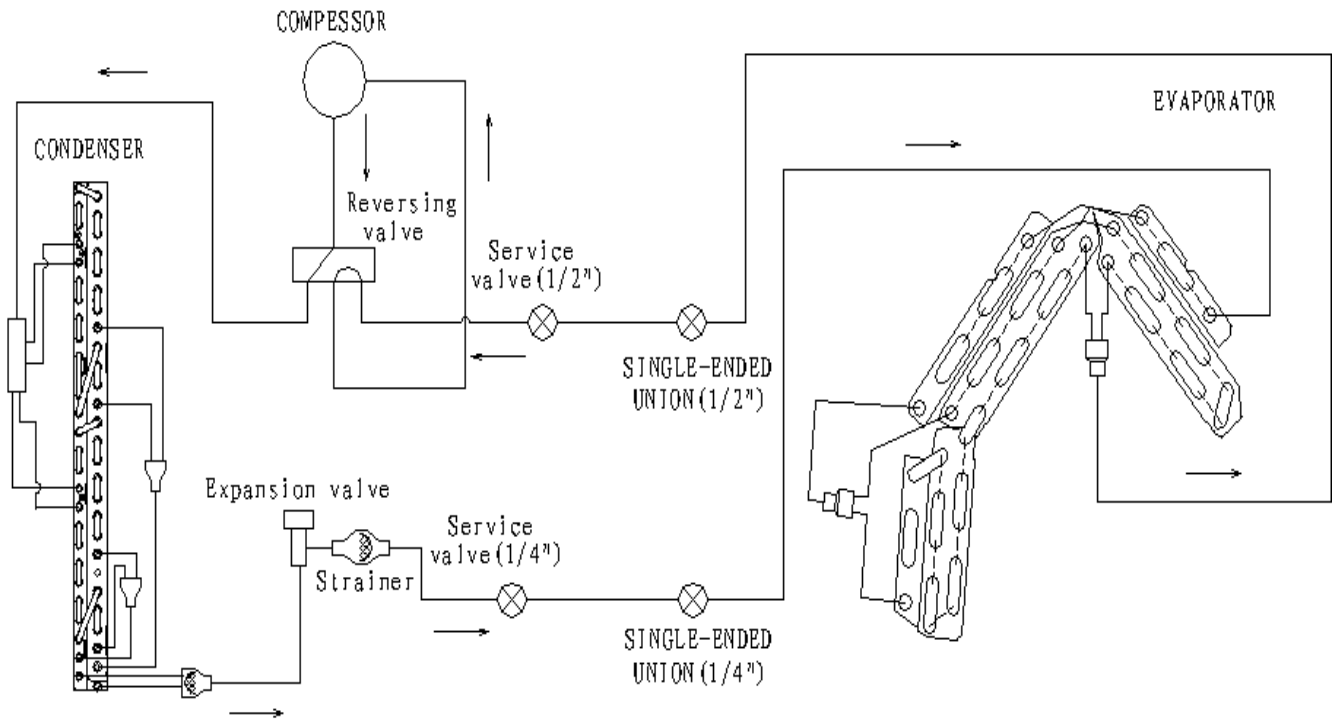















8 REFRIGERANT CYCLE

8.1. WALL TYPE: RAK-18PSC/25PSC/35PSC / RAC-18WSC/25WSC/35WSC



9 CONTROL AND FUNCTION

9.1. WIRELESS REMOTE CONTROL FUNCTION

BUTTONS	FUNCTION
	MODE Selector Use this button to select the operating mode. Every time you press this button, the mode will change from (AUTO) → (HEAT) → (DEHUMIDIFY) → (COOL) and → (FAN) cyclically.
	FAN SPEED Selector Button This determines the fan speed. Every time you press this button, the airflow rate will change from (AUTO) → (HIGH) → (MED) → (LOW) → (SILENT) (This button allows selection of optimal or preferred fan speed for each operation mode).
	START/STOP button Press this button to start operation. Press it again to stop operation.
	ECO button Use this button to set the ECO mode.
	POWERFUL button Use this button to set the POWERFUL mode.
	SILENT button Use this button to set the SILENT mode.
	INFO button 1) Press this button to display temperature for 10 seconds. 2) Press this button to check monthly power consumption. 3) Press this button to receive the current calendar and clock.
	ECO SLEEP TIMER button Use this button to set the ECO sleep timer.
	AUTO SWING (Vertical) button Controls the angle of the horizontal air deflector.
	WIND MODE button Controls the angle of the vertical air deflector, direct airflow and indirect airflow.
	LEAVE HOME button Prevent the room temperature from falling too much by setting temperature 10°C automatically when no one is at home.
WEEKLY TIMER buttons	
	ON/OFF TIMER button The device will turn on (off) and off (on) at the designated time.
	TIME button Press the button to set starting time of the program
	OK button Press the button to save the program. The button shall be pressed everytime after finishing a program setting.
	DELETE button 1) Press the button to delete the selected program. 2) Press the button for about 10 seconds by directing the remote controller towards the indoor unit while Mode A or B display blinks, programs for Mode A or B will be deleted both from the indoor unit and the remote controller after the beep sound from the indoor unit.
	DAY button Select the desired day of the week.
	PROGRAM NO. button Press this button to select a program number.
	CANCEL 1) Press the button to cancel the current setting process on the screen. 2) Press the button by directing the remote controller towards the indoor unit, then weekly timer setting will be canceled from indoor unit after the beep sound from the indoor unit. The program setting remains in the remote controller.
	SEND button Press the button for about 3 seconds by directing the remote controller towards the indoor unit after finishing the program setting. Timer lamp on the indoor unit will blink rapidly and after the beep sound from indoor unit, TIMER lamp will light up.
	CLOCK button Press the button to set calendar and clock.
	WEEKLY TIMER MODE button 1) Select Mode A or Mode B. 2 modes can be set and stored as a weekly timer. 2) By pressing the button longer than 3 seconds, program setting screen will appear.



RAR-5W2

9.2. AUTO CHANGEOVER

COOLING/HEATING mode is decided by the room temperature.

- A. COOLING/HEATING mode is decided during the **initial startup** of Automatic Operation
 Initial startup of Automatic Operation means the following either condition:
- Unit start up in Automatic Operation
 - Automatic Operation mode is pressed while the unit is running in manual mode

Startup room temperature	COOL / HEAT
>= Remote controller setting temperature	Unit runs in COOLING mode
< Remote controller setting temperature	Unit runs in HEATING mode

- B. COOLING/HEATING mode is decided in **intervals after the initial startup** of Automatic Operation (also known as Auto Changeover function)

Intervals	Duration
1 st interval	10 minutes
2 nd interval	15 minutes
Subsequent interval	Every 55 minutes

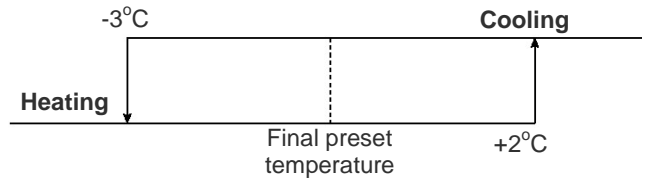

9.3. SHIFT VALUE

1. Press and hold \odot (START/STOP) button and \odot (ON) button.
2. Press \odot [RESET] button on the same time. Release \odot [RESET] button only, then release \odot (START/STOP) and \odot (ON) button once Screen 1 appears.

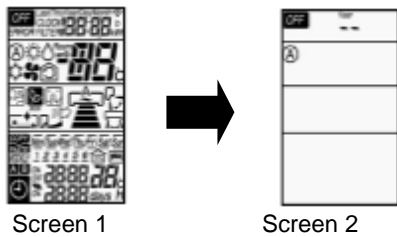

4. Press \odot (START/STOP) and Screen 4 appear.

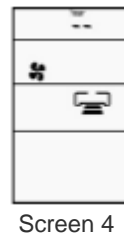

5. Select FAN (FAN SPEED) button to choose Heating Shift or Cooling Shift Mode (Screen 5).

By setting fan speed to HIGH FAN or MED FAN , it will go to Cooling Shift mode.
 By setting fan speed to LOW FAN or SILENT FAN , it will go to Heating Shift mode.

3. Press the MODE (MODE) button to display fan mode (Screen 3).

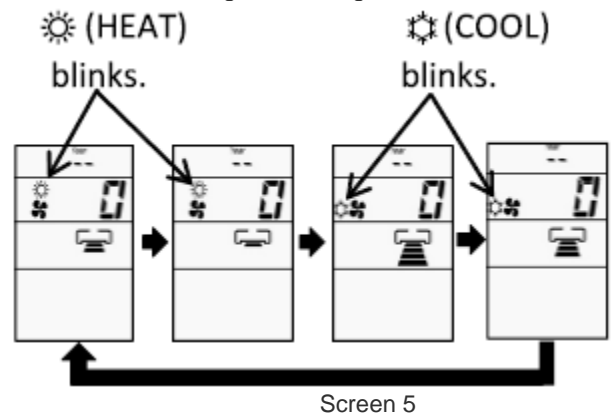
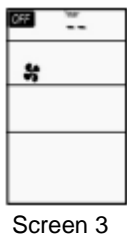

6. Press the Temperature button (V or ^) to adjust the shift value.

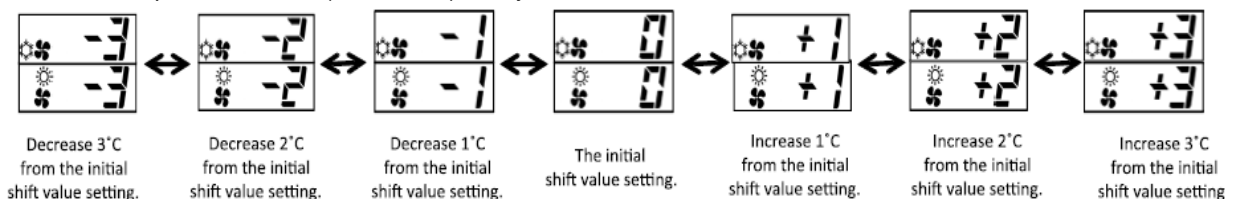







NOTE:

1. There are total of 7 shift values ranging from -3 to 3.
2. The displayed shift value, ☀ (HEAT) and ❄ (COOL) symbol on the remote controller display will be disappear after 10 seconds
3. The changed shift value will remain unchanged after turned off the power.
4. If "0" is displayed on the remote controller display, it indicates the shift value is now at the initial setting.

9.4. OPERATION LOCK

1. HEATING MODE

- a) Press and hold  (ECO) and  (POWERFUL) buttons, press  (RESET) button on the same time. Release  (RESET) button only when Screen 1 appear, then release  (ECO) button and  (POWERFUL) button.



Screen 1



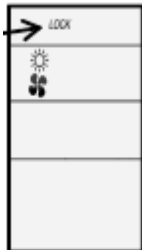

- b) Wait until only Screen 2 appear.





Screen 2

- c) The heating mode operation is locked.
 d) To unlock HEATING mode, repeat step (a). After all operations mode symbols displayed for 10 seconds, the operation mode symbol before cancellation will be display. The heating mode operation is unlocked.

2. COOLING AND DEHUMIDIFYING MODE

- a) Press and hold  (ECO) and  (SILENT) buttons for at least 5 seconds when the remote controller is OFF.
 b) Wait until only  and  displayed on the screen. The cooling and dehumidifying modes operation is locked.
 c) To unlock HEATING mode, repeat step (a). After all operations mode symbols displayed for 10 seconds, the operation mode symbol before cancellation will be display. The cooling and dehumidifying mode operation is unlocked.

9.5. SETTING THE PREVENTION OF MUTUAL INTERFERENCE

1. Please ensure the other indoor unit is OFF.
2. Press  (PROGRAM NO.) button,  (ON TIMER) button and  (RESET) button simultaneously. The remote controller will display Screen 1 and followed by Screen 2. The indoor unit beeps to indicate that it has just received the signal from remote controller.



Screen 1

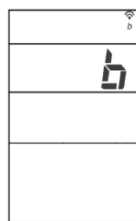



Screen 2

NOTE:

1. If indoor unit still not receive the correct signal from the correct remote controller, setting shall be made again. By setting again for the 2nd time, the signal address will change from B to A, then repeat again for the 3rd time.

9.6. ERROR CODE INFORMATION

1. In case failure occurs to the air conditioner, by pressing  (INFO) button, an error code will be displayed.
2. Direct the remote controller towards the receiver of indoor unit (within 2 meters in from of indoor unit) and press  (INFO) button.
3. Wait for 2 seconds for signal transmission and the error code will be displayed.

	TIMER LAMP BLINKING	LED301 BLINKING	CODE	MEANING
INDOOR	-	-	000 00	Normal
	1 time	-	001 00	Refrigerant cycle fault
	2 times	-	-	Outdoor unit is under forced operation
	3 times	9 times	003 00	Communication error between indoor and outdoor units
	9 times	-	009 00	Indoor thermistor defective
	10 times	-	010 00	Abnormal rotating numbers
	13 times	-	013 00	IC401 data reading error
OUTDOOR	4 times	2 times	002 01	Peak current cut
	4 times	3 times	003 01	Compressor abnormal low speed rotation
	4 times	4 times	004 01	Compressor switching failure
	4 times	5 times	005 01	Overload lower limit cut
	4 times	6 times	006 01	OH thermistor temperature rise
	4 times	7 times	007 01	Abnormal outdoor thermistor
	4 times	9 times	009 01	Communication error
	4 times	10 times	010 01	Abnormal power source
	4 times	11 times	011 01	Fan stop for strong wind
	4 times	12 times	012 01	Fan motor fault
	4 times	13 times	013 01	EEPROM reading error
	4 times	14 times	014 01	Active converter defective
	4 times	15 times	015 01	Abnormal PWB circuit
4 times	16 times	016 01	High load stop	

9.7. ADDITIONAL FUNCTION VIA DIP-SWITCH SETTINGS

A new DIP Switch is available on the PWBs of the indoor unit that provide additional functions via the settings on the switches.

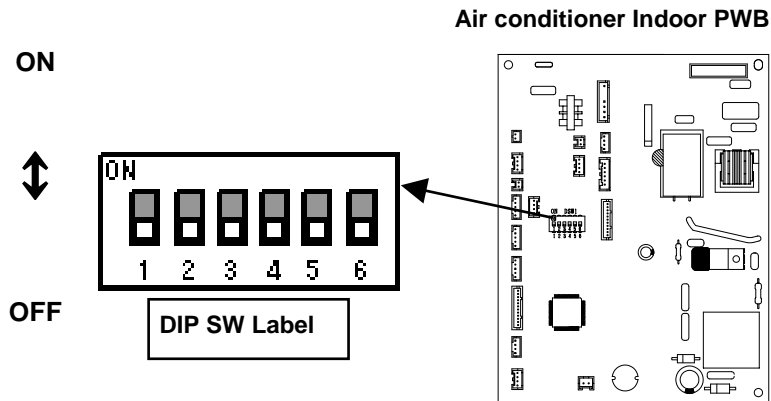

SW No.	I T E M	F U N C T I O N							
1	AUTO RESTART	OFF*	ENABLE	ON	DISABLE				
2	CARD KEY MODE	OFF*	DISABLE	ON	ENABLE				
3	CARD KEY LOGIC SELECT	OFF*	INPUT HIGH ACTIVE	ON	INPUT LOW ACTIVE				
4	HEATING/COOLING ONLY MODE SELECT	OFF*	HEATING & COOLING	OFF	HEATING ONLY	ON	COOLING ONLY	ON	HEATING & COOLING
5	HEATING/COOLING ONLY MODE SELECT	OFF*		ON		OFF		ON	
6	REMOCON ID SELECT	OFF*	SELECT ID : A	ON	SELECT ID : B				

NOTE:

* Marking is position of shipping [FACTORY default setting]

9.7.1. AUTO RESTART FUNCTION

The AUTO RESTART function can be enabled or disabled by setting Pin No. 1 on the DIP SWITCH above to the ON or OFF position accordingly.











9.7.2. HEATING/COOLING ONLY MODEL SELECTION

When this function is enabled, the operation mode could be locked to either Heating Only (Heating or Fan) or Cooling Only (Cooling, Fan or Dehumidifying) by setting the Pin No. 4 and 5 accordingly.

LOCKED MODE	REMARKS
HEATING ONLY	Unit will not enter into Cooling mode although cooling mode is selected using the remote controller.
COOLING ONLY	Unit will not enter into Heating mode although heating mode is selected using the remote controller.

10 OPTION LIST

10.1 WIRED REMOTE CONTROL

	BUTTONS	FUNCTION
 <p>RAR-5G2 (SPX-RCDB)</p>		MODE Selector Use this button to select the operating mode. Every time you press this button, the mode will change from (AUTO) → (HEAT) → (DEHUMIDIFY) → (COOL) and → (FAN) cyclically.
		FAN SPEED Selector Button This determines the fan speed. Every time you press this button, the airflow rate will change from (AUTO) → (HIGH) → (MED) → (LOW) → (SILENT) (This button allows selection of optimal or preferred fan speed for each operation mode).
		ON/OFF button Press this button to start operation. Press it again to stop operation.
		SLEEP button Use this button to set the SLEEP timer.
		SET button Timer setting reservation.
		OFF button Select the turn OFF timer.
		ON button Select the turn ON timer.
		CANCEL button Cancel timer reservation.
		AUTO SWING (Vertical) button Controls the angle of the horizontal air deflector.
		ROOM TEMPERATURE setting button Value will change quicke when keep pressing.

10.1.1 SHIFT VALUE

1. Press and hold (ON/OFF) button and (ON TIMER) button at the same time while giving a single press on the RESET button until remote controller now enter 'Shift value change mode'.
2. Press (ON/OFF) button so that the display indicates (FAN) speed.
3. Select (FAN SPEED) button to choose Heating Shift or Cooling Shift Mode.

By setting fan speed to HIGH (HIGH) or MED (MED), it will go to Cooling Shift mode.

By setting fan speed to LOW (LOW) or SILENT (SILENT), it will go to Heating Shift mode.







4. Press (ROOM TEMPERATURE) button to change the shift value (-3°C ~ 0 ~ 3°C).
5. Press (ON/OFF) button to end 'Shift value setting mode'.

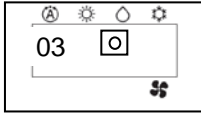

NOTE:

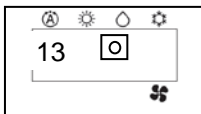
1. There are total of 7 shift values ranging from -3 to 3.
2. The changed shift value will remain unchanged after turned off the power.

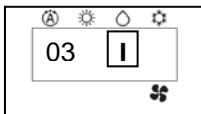
10.1.2 ERROR CODE INFORMATION

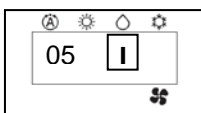
- In case failure occurs to the air conditioner, the error code will constantly appear on the wired remote controller display.

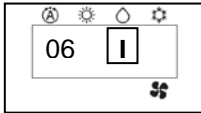
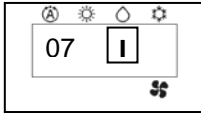
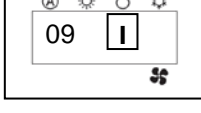
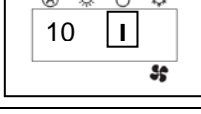
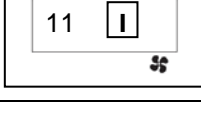
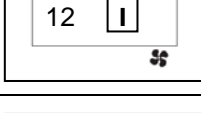
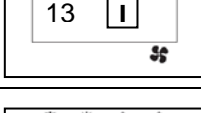
	TIMER LAMP BLINKING	LD301 BLINKING	CODE	MEANING
INDOOR	-	-	-	Normal
	1 time	-		Refrigerant cycle fault
	2 times	-	-	Outdoor unit is under forced operation
	3 times	9 times		Communication error between indoor and outdoor units
	9 times	-		Indoor thermistor defective
	10 times	-		Abnormal rotating numbers
	13 times	-		IC401 data reading error
OUTDOOR	4 times	2 times		Peak current cut
	4 times	3 times		Compressor abnormal low speed rotation
	4 times	4 times		Compressor switching failure
	4 times	5 times		Overload lower limit cut

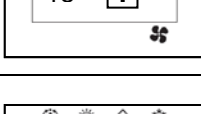
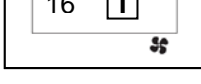
	TIMER LAMP BLINKING	LD301 BLINKING	CODE	MEANING
OUTDOOR	4 times	6 times		OH thermistor temperature rise
	4 times	7 times		Abnormal outdoor thermistor
	4 times	9 times		Communication error
	4 times	10 times		Abnormal power source
	4 times	11 times		Fan stop for strong wind
	4 times	12 times		Fan motor fault
	4 times	13 times		EEPROM reading error
	4 times	14 times		Active converter defective
	4 times	15 times		Abnormal PWB circuit
	4 times	16 times		High load stop

10.2 H-LINK ADAPTOR

10.2.1 SAFETY SUMMARY

DANGER:

- DO NOT pour water into the remote control switch (hereafter called "controller"). This product is equipped with electrical parts. This will cause serious electrical shock.

WARNING:

- DO NOT perform installation work and electrical wiring connection by yourself. Contact your distributor or dealer of HITACHI and ask them for installation work and electrical wiring by service person. The specified cable should be used to connect (i) room air conditioner and adaptor, and (ii) controller and adaptor.



CAUTION:



- DO NOT install the indoor unit, outdoor unit, controller and cable as such places as:
 - where there is oil vapor and dispersion of oil
 - where there is sulfuric environment (near the hot springs)
 - where there is a flammable gas
 - where there is salty environment (near the sea)
- DO NOT install the indoor unit, outdoor unit, controller and cable within approximately 3 meters from strong electromagnetic wave radiators, such as medical equipment. In case that the controller is installed in a place where there is electromagnetic wave direct-radiation, shield the controller and cables by covering with the steel box and running the cable through the metal conduit tube.
- In case that there is electric noise at the power source for the indoor unit, provide a noise filter.

10.2.2 INSTALLATION WORK

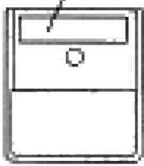
■ Before installation

Check the contents and the number of the accessories in the packing.

Adaptor	 <p>With two 1.8m cables</p>
1 piece of cover for hiding the covering	 <p>Attached 2 sided tapes</p>
Two-sided tape for attaching to Adaptor	 <p>110x40x3mm</p>

2 connectors for H-Link connection		
2 tapping screws for attaching to wall		φ3.0 x 10mm
2 screws for attaching to wooden wall		φ3.1 x 16mm

- 1) RAC adaptor can be installed to the wall as well as on the air conditioner itself
- 2) Install RAC adaptor in the vertical surface as shown below.

Upper side

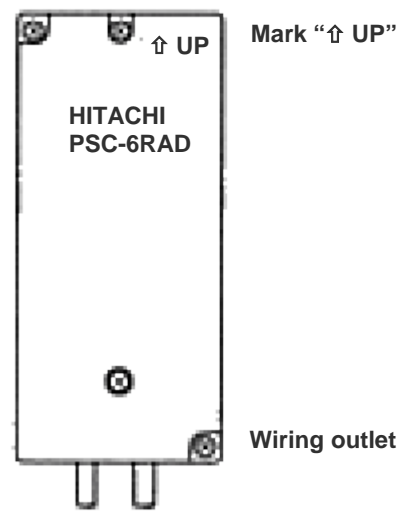

Bottom side

- 3) Installation procedure
 - a) When installing to the wall.
 - i) Fix the adaptor with 2 screws. Tapping screw is for metal surface, and other screw is for wooden surface.

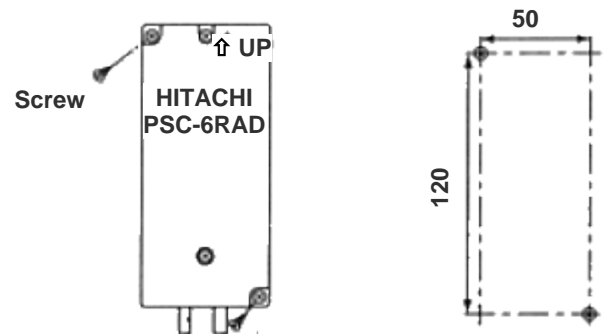

- ii) When using the cover
It can be installed at the right and left side of room air conditioner. Fix the cover and RAC adaptor with the two-sided tape (accessory).

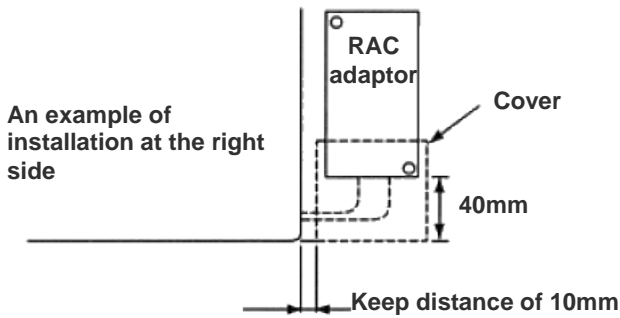

- b) When installing on the room air-conditioner
- In case that it cannot be installed to the wall due to the space or material problem, install the RAC adaptor with the two-sided tape (accessory) on the room air-conditioner.
- Confirm if the piping cover of the unit can be removed when performing the service maintenance, and then fix the RAC adaptor in the side of room air-conditioner with two-sided tape. (Available at the right as well as left side)
 - Clean the surface to be installed with a dry cloth.

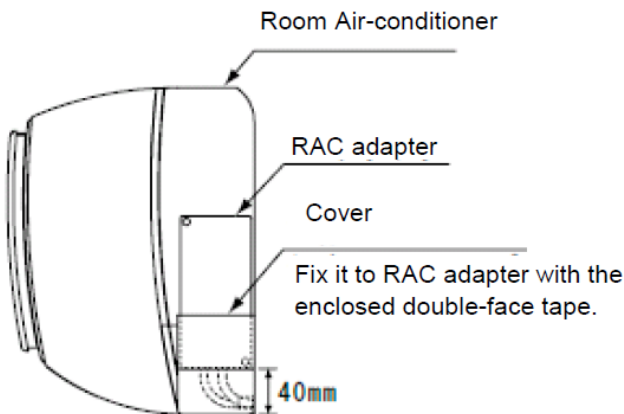
**NOTE:**

- Consider the following points since the adhesiveness changes according to the environmental conditions (temperature, humidity etc)
- The adhesiveness is decreased when there is humidity or oil.
- Warm the adhesive part and installation place of the two-sided tape to avoid the decrease of the adhesiveness in case the ambient temperature is low.
- DO NOT touch the adhesive part by fingers nor re-attach it many times. The adhesiveness has decreased and the RAC adaptor may fall off.
- DO NOT apply any force within 24 hours after installation.

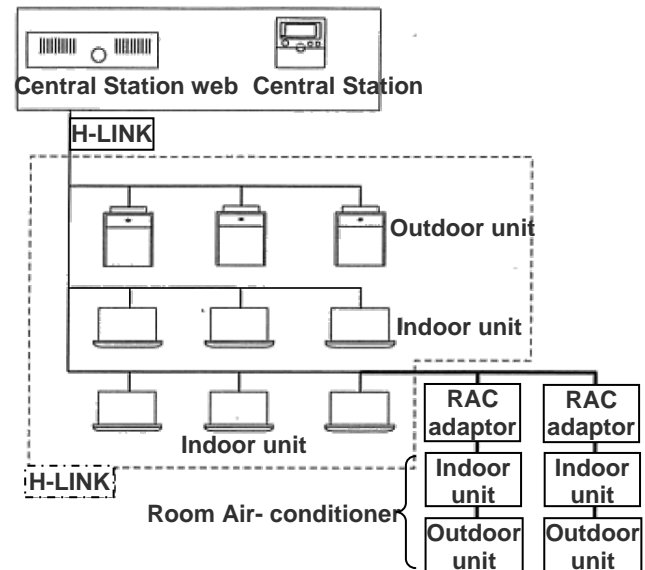
10.2.3 ELECTRICAL WIRING**■ System configuration****CAUTION:**

- Turn OFF the power supply of the room air-conditioner of the central control device when performing the wiring work
- DO NOT run all the H-LINK cable or power supply cable along the other signal cable, or malfunction may occur due to the noise, etc. If it is required to run along the other transmission cable, separate the cable more than 30cm, or run the cable through the metal tube and earth the tube.
- Follow local codes and regulations when performing electrical wiring and earth wiring.
- Transmissions cable used in H-LINK shall be 2 cores cable (0.7mm^2 to 1.25mm^2 for model: VCTF, VCT, CVV, MVVX, CVVX, VVR, VVF) or 2 cores twisted pair cable (model: KPEV, KPEV-Spec). Total length of cable shall be below 1000mm.
- DO NOT use wire with more than 3 cores.

■ Internal components and Wiring connections

Check the contents and the number of the accessories in the packing.

- Access
Open the cover by removing the ① and ② screws.

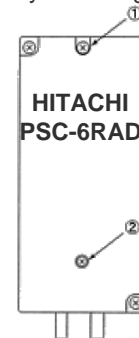

- Wiring Connection
Connection with Room Air-Conditioner
 - Remove the front cover of the room air-conditioner and the cover of electrical box.
 - The cable attached with the connector of the RAC adaptor shall be connected with the connector of indoor PCB

- iii) Install the electrical box cover paying attention not to clamp the cable. Read the installation manual of each room air-conditioner for confirming how to connect and how to assemble the cable of the RAC adaptor.

CAUTION:

- Disconnect the power plug before performing this work
- Turn OFF the break power source in case the power is supplied from the outdoor unit.
- Connection of Transmission Cable
H-LINK transmission cable connecting to RAC adaptor shall be connected to H-LINK.

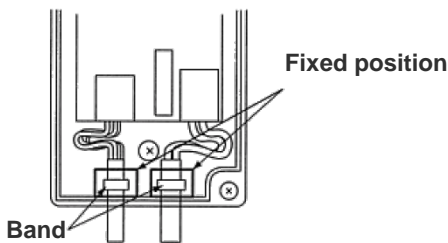
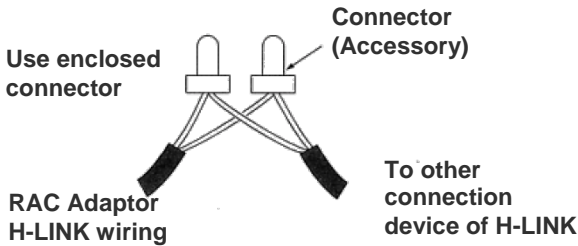

CAUTION:

- DO NOT connect incorrect wiring. It may cause the failure of the RAC Adaptor. Especially pay attention not to apply high voltage e.g. AC400/230V.
- DO NOT perform the wiring work while power to the central station or the RAC Adaptor is still being supplied. It may cause malfunction. Turn OFF devices when performing the wiring work.
- The RAC Adaptor side cable should not overload to the connector.
- DO NOT clamp the cable when attaching the RAC adaptor cover.
- Band should not be loose and in fixed position.

10.2.4 DIP SWITCH SETTING

- 1) Switch OFF the power of room air conditioner before setting the DIP switch. If the power is ON, the settings are INVALID.
- 2) The position of the DIP switch is shown below.

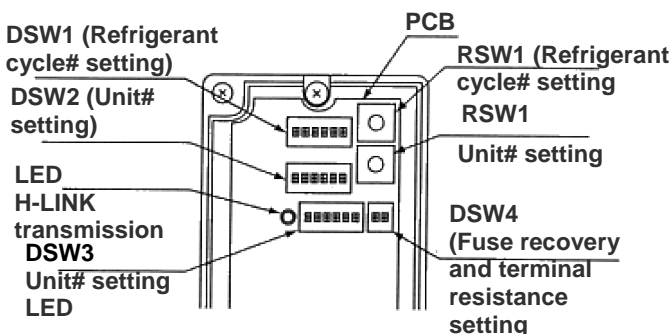

CAUTION:

- DO NOT turn ON various pins of DSW1 and DSW2

- 3) Set the refrigerant cycle# by RSW1 and DSW1

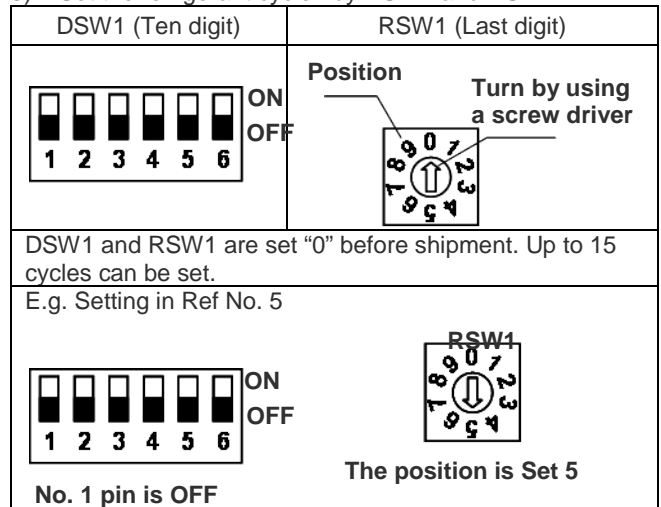

- 4) Set the unit No. by RSW2 and DSW2

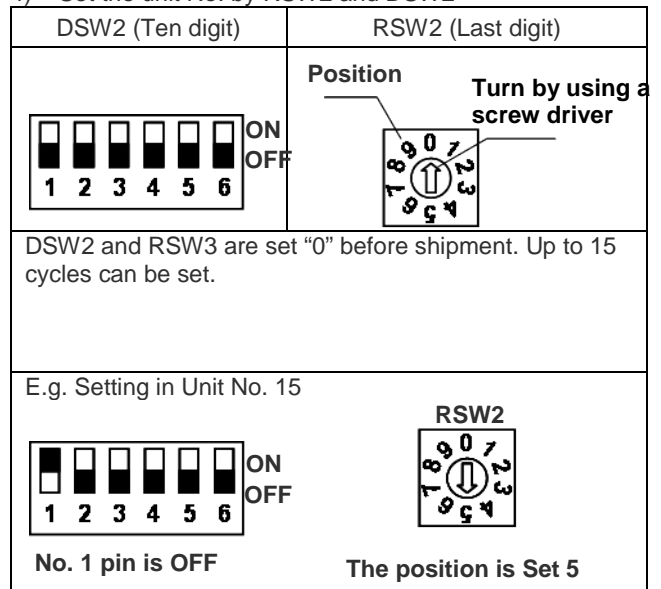

- 5) Slave unit.

In case of setting various RAC adaptors in the same refrigerant cycle, set the RAC adaptor with smallest Unit# as a master unit. In case of setting only one RAC adaptor in a refrigerant system, this adaptor should be a master unit. Set this procedure by DSW3.

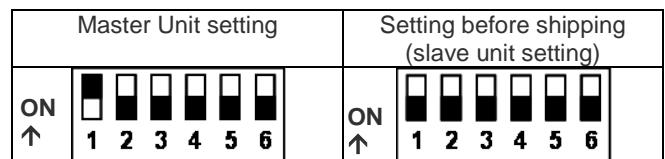

●: Master Unit setting

○: Setting before Shipping (Slave Unit setting)

		Indoor Unit#							
		0	1	2	3	4	5	6	7
Refrigerant Unit#	0	●	○	○	○	○			
	1			●	○	○			
	2				●	○	○	○	○
	3		●						
	4								

CAUTION:

– DO NOT set various main adaptors in the same refrigerant cycle.

- 6) Procedure when applying 200V voltage to H-LINK wiring incorrectly.

In case of applying 200V voltage to H-LINK wiring incorrectly, the fuse installed in a transmission circuit on PCB will blow out. In this case, reconnect the wiring correctly and turn ON No. 2 pin of DSW4 on PCB. The transmission circuit can be recovered. (If applying this error again, the transmission circuit can not be recovered)

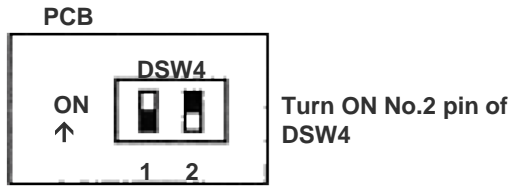

- 7) Terminating resistance is set in whole H-LINK system.
 - a) If H-LINK connecting devices like package air-conditioner are connected besides the RAC Adaptor, set the terminating resistance by those connecting devices. The terminating resistance should be set ON in only one position in whole H-LINK system.
 - b) In case that H-LINK is connected only by the RAC adaptor, set the terminating resistance by the RAC adaptor. The terminating resistance should be set ON in only one position in whole H-LINK system.

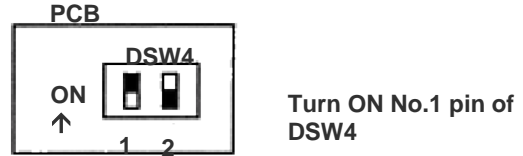

10.2.5 TEST RUN

Test run should be performed in the following after finishing the installation, wiring and setting. Refer to the installation manuals enclosed with the control system equipment.

- 1) Confirmation of RAC Adaptor Connection

Confirm if the RAC adaptor connection is recognized in the control system equipments. In case that it is not confirmed, check the transmission cable, refrigerant cycle #, indoor unit #, terminal resistance setting etc.
- 2) Registration

Confirm if the RAC adaptor connection is recognized.
- 3) Confirmation of RUN/STOP Operation.

Confirm if the room air-conditioner operate correctly by RUN/STOP from the central control system equipments. Check also if the room air-conditioner operation changes correctly by each setting.

10.3 DRY CONTACT APPLICATION (USING DIP SWITCH)

The dry contact system enables the operation of the air conditioner indoor unit to be controlled by using external dry contacts (with non voltage) such as card-key controller or window for facilities such as hotels.

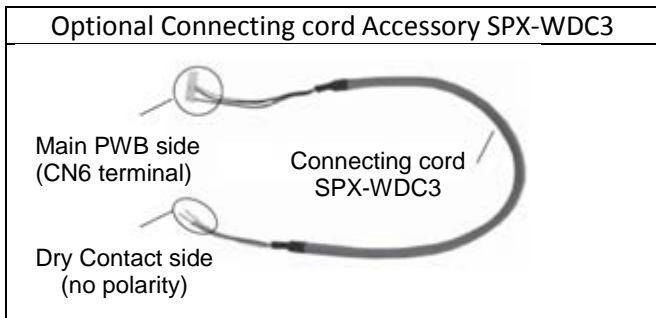

Note:

- 1) AUTO RESTART function set to "Enable" is needed (set pin#1 on the DIP SWITCH SW501 above to OFF position).
- 2) DRY CONTACT function is "Enable" by set pin No. 2 of the DIP SWITCH (DSW1) to ON position.
- 3) Select the proper setting for DRY CONTACT LOGIC INPUT pin No. 3 on DIP SWITCH (DSW1)
 - i) Set to OFF position (Hi Input) if the type of Dry Contact switch to be used (for the CARD KEY UNIT or Window) is of contact type a (Normally Open Type) as shown in below diagram.
 - ii) Set to ON position (Lo Input) if the type of Dry contact switch to be used (for the CARD KEY UNIT or Window) is of contact type b (Normally Close Type) as shown in below diagram.

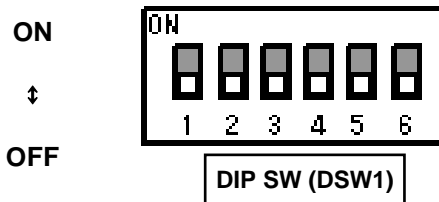

Pin No.	Function	Switch Position / Setting			
		OFF	Disable	ON	Enable
2	DRY CONTACT function	OFF	Disable	ON	Enable
3	DRY CONTACT Input Logic	OFF	HI Input Active	ON	LO Input Active

- Please decide the type of dry contact you will be using and set the position of the DIP Switch No. 2 and 3 accordingly

[1] CHECK DRY CONTACT OF CARD KEY UNIT

	AIR CONDITIONER Standby	AIR CONDITIONER Operating
	CARD KEY (Door Switch)	REMOVE
Contact type a	OPEN 	CLOSE
Contact type b	CLOSE 	OPEN

[2] SET THE POSITION OF DIP SWITCH

POSITION CONDITION OF DIP SWITCH	
INITIAL CONDITION (CARD KEY NO USE) No.2 : OFF No.3 : OFF	
 HI Input Active No.2 : ON No.3 : OFF	
 LO Input Active No.2 : ON No.3 : ON	

After all connection has been done as below diagram, ON the breaker and push ON button of wireless remote controller or wired remote controller to operate the air conditioner unit.

- When the CARD KEY is in insert condition, the air conditioner operation is allowable by remote controller.
- When the dry contact switch on the Card Key Unit is open (refer to diagram below for contact type a), the unit stops to operate (it takes 10 seconds to stop the unit operation after the dry contact switch on the card key turns off) and vice versa.
- When the card key is removed from the Card Key Unit, the wireless remote controller cannot be used.
- When the card key is removed from the Card Key Unit, the wired remote controller LCD display is activated; however it has no control over the unit.
- The suitable accessory Connecting Cord (accessory code#: SPX-WDC3) need to be used to connect the Card Key Unit's dry contact switch to the connector on the control board of the indoor unit. Please refer to Table 1 to select suitable accessory code# for the concerning indoor model.

Example of wiring connection to Card Key Unit will be as below (reference only)

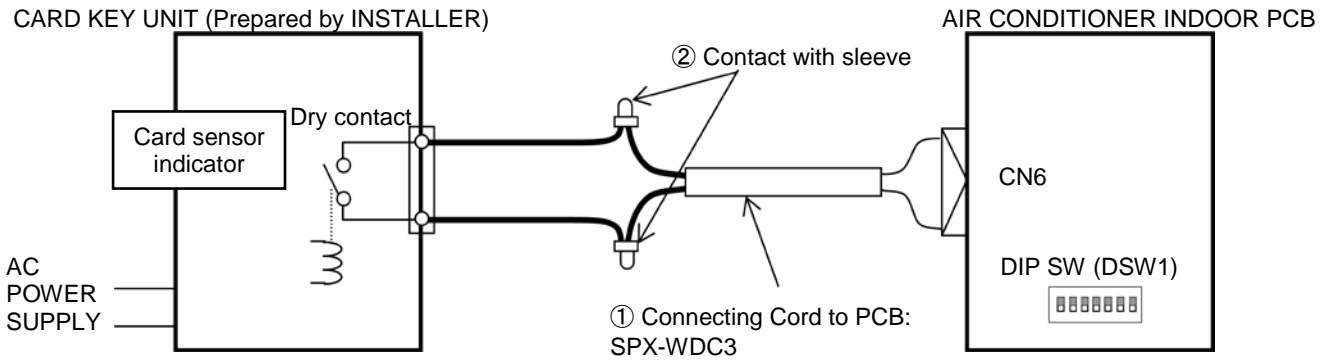

• CONNECTION EXAMPLE

i. Pin No. 3 of DIP SWITCH is set to OFF position (HI Input Active) for Dry Contact Type a

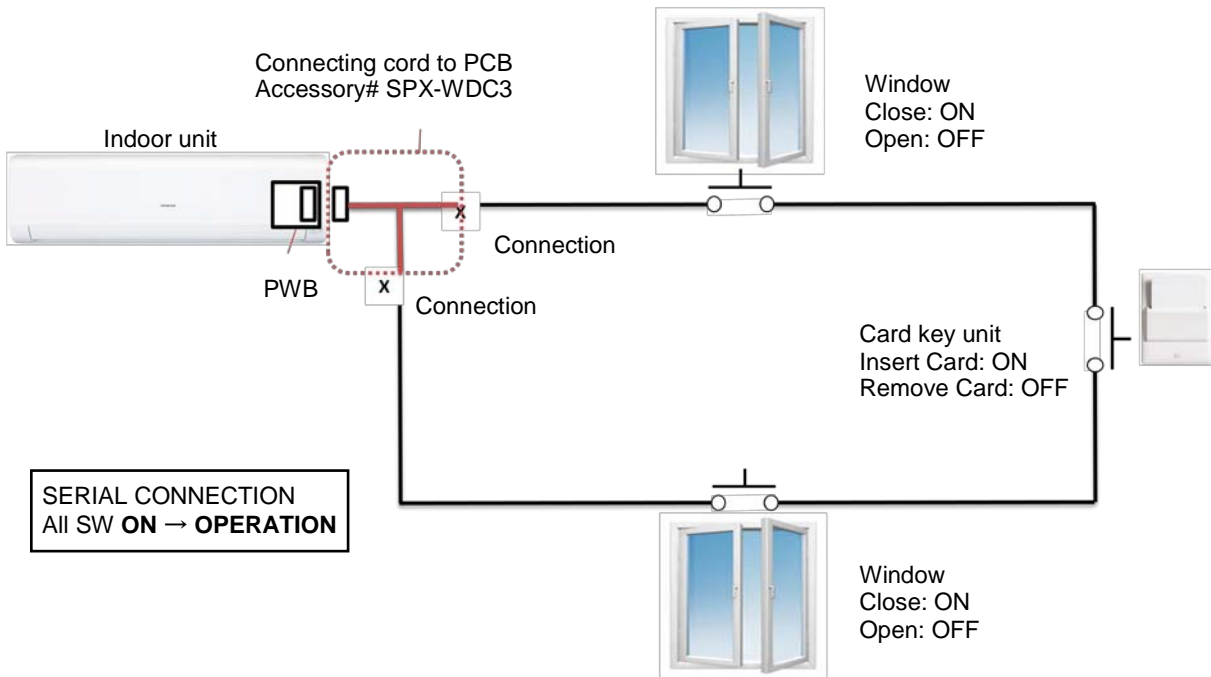

ii. Pin No. 3 of DIP SWITCH is set to ON position (LO Input Active) for Dry Contact Type b

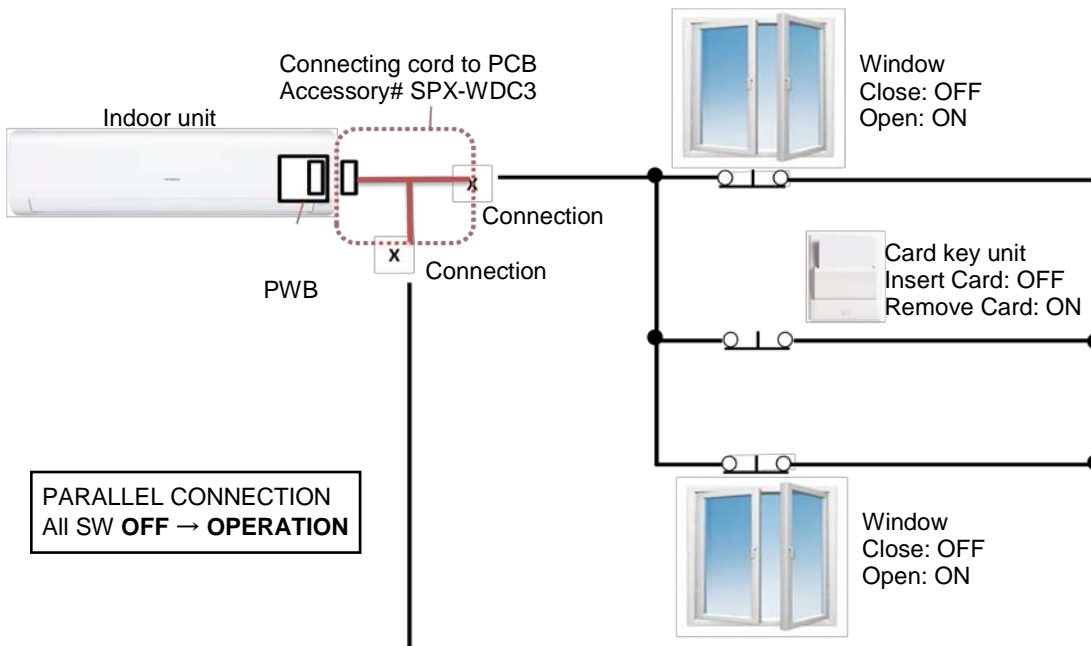

Please refer to the actual manual supplied with the optional connecting cords SPX-WDC3 for more details.

HITACHI

TC-ERP-Model

INDOOR

RAK-18PSC
RAK-25PSC
RAK-35PSC

OUTDOOR

RAC-18WSC
RAC-25WSC
RAC-35WSC