

AIR CONDITIONER

Cassette type

DESIGN & TECHNICAL MANUAL

INDOOR

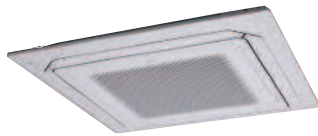

AUXG18KRLB
AUXG22KRLB

OUTDOOR



AOYG18KBTB
AOYG22KBTB

FUJITSU GENERAL LIMITED

Notices:

- Product specifications and design are subject to change without notice for future improvement.
- For further details, please check with our authorized dealer.

Trademarks

FGLair™ is trademark of Fujitsu General Limited in the United States, other countries or both.

Google Play™ is trademark of Google Inc.

App Store® is a service mark of Apple Inc., registered in the U.S. and other countries.

CONTENTS

Part 1. INDOOR UNIT	1
1. Specifications	2
2. Dimensions	4
2-1. Models: AUXG18KRLB and AUXG22KRLB	4
2-2. Installation space requirement	5
3. Wiring diagram	7
3-1. Models: AUXG18KRLB and AUXG22KRLB	7
4. Capacity table	8
4-1. Cooling capacity.....	8
4-2. Heating capacity	9
5. Fan performance	10
5-1. Air velocity distributions.....	10
5-2. Airflow	14
5-3. Fresh-air characteristics.....	15
5-4. Duct connection	16
6. Operation noise (sound pressure)	18
6-1. Noise level curve.....	18
6-2. Sound level check point	19
7. Safety devices	20
8. External input and output	21
8-1. External input.....	22
8-2. External output.....	23
8-3. Combination of external input and output.....	24
8-4. Details of function	26
9. Function settings	32
9-1. Function settings on indoor unit	32
9-2. Function settings by using remote controller	34
10. Accessories	39
10-1. Models: AUXG18KRLB and AUXG22KRLB	39
11. Optional parts	40
11-1. Controllers	40
11-2. Cassette grille	41
11-3. Others	42

CONTENTS (continued)

Part 2. OUTDOOR UNIT	45
1. Specifications	46
2. Dimensions	47
2-1. Models: AOYG18KBTB and AOYG22KBTB	47
3. Installation space	48
3-1. Models: AOYG18KBTB and AOYG22KBTB	48
4. Refrigerant circuit	51
4-1. Model: AOYG18KBTB	51
4-2. Model: AOYG22KBTB	52
5. Wiring diagrams	53
5-1. Model: AOYG18KBTB	53
5-2. Model: AOYG22KBTB	54
6. Capacity compensation rate for pipe length and height difference	55
6-1. Model: AOYG18KBTB	55
6-2. Model: AOYG22KBTB	56
7. Additional charge calculation	57
7-1. Model: AOYG18KBTB	57
7-2. Model: AOYG22KBTB	57
8. Airflow	58
8-1. Model: AOYG18KBTB	58
8-2. Model: AOYG22KBTB	58
9. Operation noise (sound pressure)	59
9-1. Noise level curve.....	59
9-2. Sound level check point	60
10. Electrical characteristics	61
11. Safety devices	62
12. Accessories	63
12-1.Models: AOYG18KBTB and AOYG22KBTB	63

Part 1. INDOOR UNIT

CASSETTE TYPE:

AUXG18KRLB

AUXG22KRLB

1. Specifications

Type				Cassette				
				Inverter heat pump				
Model name				AUXG18KRLB	AUXG22KRLB			
Power supply				230 V ~ 50 Hz				
Power supply intake				Outdoor unit				
Available voltage range				198—264 V				
Capacity	Cooling	Rated	kW	5.2	6.0			
			Btu/h	17,700	20,500			
		Min.—Max.	kW	0.90—5.90	0.90—6.70			
			Btu/h	3,100—20,100	3,100—22,900			
	Heating	Rated	kW	6.0	7.0			
			Btu/h	20,500	23,900			
Min.—Max.		kW	0.90—7.50	0.90—8.00				
		Btu/h	3,100—25,600	3,100—27,300				
Input power	Cooling	Rated	kW	1.36	1.71			
				Max.	2.79	2.90		
	Heating	Rated	1.58	1.82				
			Max.	2.79	2.90			
Current	Cooling	Rated	A	6.0	7.5			
	Heating			6.9	8.0			
Power factor	Cooling		%	98.6	99.1			
	Heating			99.6	98.9			
EER	Cooling		kW/kW	3.82	3.51			
COP	Heating			3.80	3.85			
Moisture removal			L/h (pints/h)	1.5 (2.6)	2.2 (3.9)			
Maximum operating current *1	Cooling		A	12.1	12.6			
	Heating			12.1	12.6			
Fan	Airflow rate	Cooling	m ³ /h	HIGH	1,050			
				MED	960			
				LOW	900			
				QUIET	780			
		Heating		HIGH	1,050			
				MED	960			
				LOW	900			
				QUIET	780			
	Type × Q'ty			Turbo fan × 1				
	Motor output			W				
Sound pressure level *2	Cooling		dB (A)	HIGH	33			
				MED	32			
				LOW	31			
				QUIET	28			
	Heating			HIGH	33			
				MED	32			
				LOW	31			
				QUIET	28			
				Heat exchanger type			mm	
				Dimensions (H × W × D)			210 × 2,127 × 13.3	
Fin pitch			210 × 2,061 × 13.3					
Rows × Stages			1.2					
Pipe type			2 × 10					
Fin type			Copper tube					
Dimensions (H × W × D)			Aluminum					
Weight	Net		mm	246 × 840 × 840				
	Gross			298 × 960 × 950				
Connection pipe	Size	Liquid	mm (in)	Ø 6.35 (Ø 1/4)				
		Gas		Ø 12.70 (Ø 1/2)				
Method			Flare					
Drain hose	Material		PVC(VP25)					
	Size		mm					
Operation range	Cooling		°C					
			18 to 32					
	Heating		%RH					
		80 or less						
		°C		16 to 30				
Cassette grille (Option)	Material			Polystyrene				
	Color			White				
				Approximate color of MUNSSELL N 9.25/				
	Dimensions (H × W × D)	Net	mm	53 × 950 × 950				
		Gross		110 × 1,000 × 1,010				
	Weight	Net	kg	6.0				
Gross		10.0						
Remote control (Option)				Wired remote controller, Wireless remote controller, Mobile app*3 (FGLair™)				

NOTES:

- Specifications are based on the following conditions:
 - Cooling: Indoor temperature of 27 °CDB/19 °CWB, and outdoor temperature of 35 °CDB/24 °CWB.
 - Heating: Indoor temperature of 20 °CDB/15 °CWB, and outdoor temperature of 7 °CDB/6 °CWB.
 - Pipe length: 5 m, Height difference: 0 m. (Between outdoor unit and indoor unit.)
- Protective function might work when using it outside the operation range.
- *1: Maximum operating current is the total current of the indoor unit and the outdoor unit.
- *2: Sound pressure level:
 - Measured values in manufacturer's anechoic chamber.
 - Because of the surrounding sound environment, the sound levels measured in actual installation conditions might be higher than the specified values here.
- *3: Available on Google Play™ store or on App Store®. Optional WLAN adapter is also required. For details, refer to the setting manual.

Specifications for ErP Lot10				
Model name		AUXG18KRLB		AUXG22KRLB
Energy efficiency class	Cooling	A ⁺⁺		
	Heating (Average)	A ⁺		
Pdesign	Cooling	kW	5.2 (35°C)	6.0 (35°C)
	Heating (Average)		4.4 (-10°C)	4.8 (-10°C)
SEER	Cooling	kWh/kWh	7.00	7.00
SCOP	Heating (Average)		4.30	4.40
Annual energy consumption	QCE	kWh/a	260	300
	QHE (Average)		1,431	1,527
Sound power level	Cooling	HIGH	dB (A)	47
	Heating			47

2-2. Installation space requirement

Provide sufficient installation space for product safety.

For 4-direction setting:

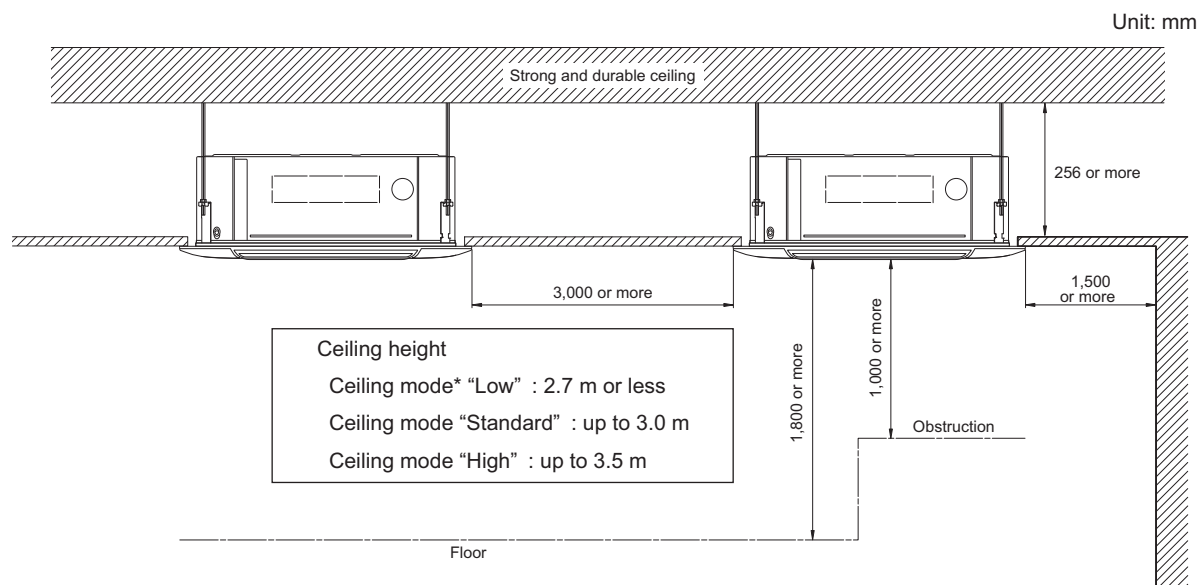

*: For switching the ceiling mode, refer to ["Contents of function setting"](#) on page 34.

For 3-direction setting:

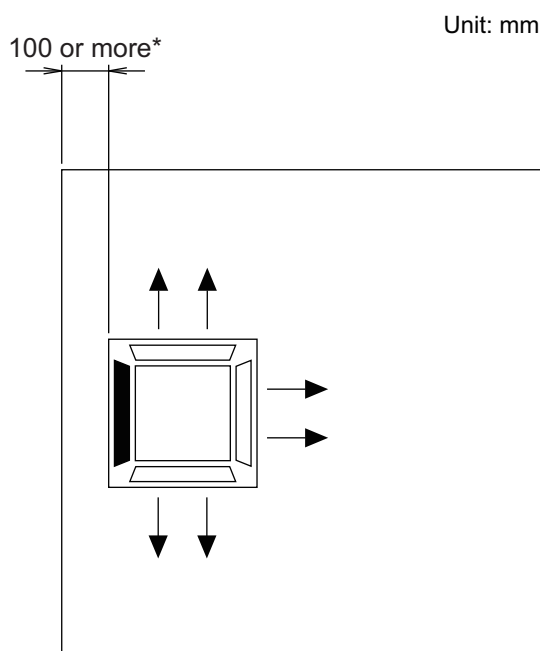

NOTES:

- To set "3-direction", optional Air outlet shutter plate (UTR-YDZK) must be installed, and the "outlet-direction" need to be switched to "3-way" by remote controller.
- *: When installing the indoor unit, be careful about the maintenance space.
- The ceiling height cannot be set in the 3-way outlet mode. Therefore, ceiling height setting change by function setting 20 is prohibited. For details, refer to ["Contents of function setting"](#) on page 34.

Human sensor (Option)

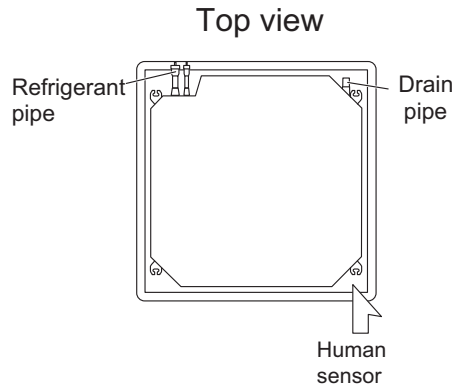

Example of sensitivity range:

When the installation height gets higher, the temperature sensitivity decreases.

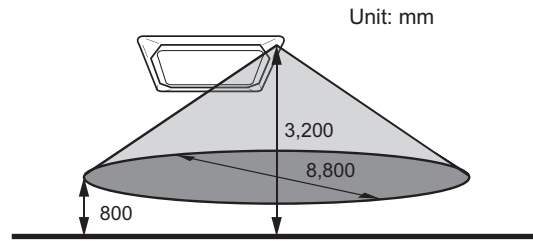

Equal sensitivity range of temperature	Ceiling height	3,200 mm
	Detecting position	800 mm from floor surface

⚠ CAUTION

Do not place large objects near the human sensor. Also keep heating units outside the sensor's detection area.

4. Capacity table

Capacity tables show each of following values calculated based on the outdoor temperature and the indoor temperature, under given Airflow Rate (AFR):

For cooling capacity: Total Capacity (TC), Sensible Heat Capacity (SHC), and Input Power (IP)

For heating capacity: Total Capacity (TC) and Input Power (IP)

4-1. Cooling capacity

■ Model: AUXG18KRLB

AFR		m ³ /h																		1,050					
		Indoor temperature																							
°CDB		18			21			23			25			27			29			32					
°CWB		12			15			16			18			19			21			23					
°CDB		TC	SHC	IP	TC	SHC	IP	TC	SHC	IP	TC	SHC	IP	TC	SHC	IP	TC	SHC	IP	TC	SHC	IP			
		kW			kW			kW			kW			kW			kW								
Outdoor temperature	-15	4.17	3.69	0.41	4.65	3.71	0.42	4.80	4.03	0.42	5.12	4.05	0.43	5.28	4.37	0.43	5.60	4.35	0.43	5.91	4.64	0.44			
	-10	4.20	3.71	0.36	4.68	3.74	0.36	4.84	4.06	0.36	5.16	4.07	0.37	5.32	4.40	0.37	5.64	4.38	0.37	5.96	4.67	0.38			
	0	3.99	3.62	0.55	4.44	3.64	0.56	4.60	3.96	0.56	4.90	3.97	0.57	5.05	4.29	0.57	5.35	4.27	0.58	5.66	4.55	0.58			
	5	3.91	3.60	0.59	4.36	3.62	0.60	4.50	3.93	0.60	4.80	3.94	0.61	4.95	4.26	0.61	5.25	4.24	0.62	5.54	4.52	0.62			
	10	4.05	3.65	0.40	4.51	3.68	0.40	4.67	4.00	0.40	4.98	4.01	0.41	5.13	4.33	0.41	5.44	4.31	0.41	5.75	4.59	0.42			
	15	3.92	3.61	0.49	4.36	3.63	0.50	4.51	3.95	0.50	4.81	3.96	0.51	4.96	4.28	0.51	5.26	4.26	0.52	5.56	4.54	0.52			
	20	4.83	3.99	0.94	5.39	4.02	0.95	5.57	4.37	0.96	5.94	4.38	0.97	6.12	4.73	0.97	6.49	4.71	0.98	6.85	5.02	0.99			
	25	4.59	3.83	1.07	5.11	3.85	1.09	5.29	4.19	1.09	5.64	4.20	1.10	5.81	4.54	1.11	6.16	4.52	1.12	6.51	4.82	1.13			
	30	4.35	3.69	1.20	4.84	3.71	1.22	5.01	4.03	1.22	5.34	4.05	1.23	5.50	4.37	1.24	5.83	4.35	1.25	6.16	4.64	1.26			
	35	4.11	3.53	1.31	4.58	3.55	1.33	4.73	3.86	1.34	5.04	3.87	1.35	5.20	4.18	1.36	5.51	4.16	1.37	5.82	4.43	1.39			
	40	3.68	3.44	1.21	4.10	3.46	1.23	4.24	3.77	1.23	4.52	3.78	1.24	4.66	4.08	1.25	4.94	4.06	1.26	5.22	4.33	1.28			
46	2.58	2.58	0.90	2.87	2.77	0.91	2.97	2.97	0.92	3.16	3.02	0.93	3.26	3.26	0.93	3.46	3.25	0.94	3.65	3.46	0.95				

■ Model: AUXG22KRLB

AFR		m ³ /h																		1,050					
		Indoor temperature																							
°CDB		18			21			23			25			27			29			32					
°CWB		12			15			16			18			19			21			23					
°CDB		TC	SHC	IP	TC	SHC	IP	TC	SHC	IP	TC	SHC	IP	TC	SHC	IP	TC	SHC	IP	TC	SHC	IP			
		kW			kW			kW			kW			kW			kW								
Outdoor temperature	-15	4.99	3.86	0.55	5.56	3.88	0.56	5.75	4.22	0.56	6.13	4.23	0.57	6.32	4.57	0.57	6.70	4.55	0.58	7.08	4.85	0.58			
	-10	5.03	3.87	0.46	5.61	3.89	0.47	5.80	4.23	0.47	6.18	4.24	0.48	6.37	4.58	0.48	6.75	4.56	0.48	7.13	4.86	0.49			
	0	4.91	3.81	0.47	5.46	3.83	0.48	5.65	4.16	0.48	6.02	4.18	0.49	6.21	4.51	0.49	6.58	4.49	0.49	6.96	4.79	0.50			
	5	4.77	3.76	0.60	5.32	3.78	0.61	5.50	4.11	0.61	5.86	4.12	0.62	6.04	4.45	0.62	6.40	4.43	0.63	6.76	4.72	0.63			
	10	4.74	3.75	0.59	5.28	3.77	0.60	5.46	4.10	0.60	5.82	4.11	0.61	6.00	4.44	0.61	6.36	4.42	0.62	6.72	4.71	0.62			
	15	4.59	3.68	0.70	5.11	3.70	0.72	5.29	4.02	0.72	5.64	4.04	0.73	5.81	4.36	0.73	6.16	4.34	0.74	6.51	4.63	0.74			
	20	5.77	4.20	1.25	6.43	4.23	1.27	6.65	4.60	1.28	7.09	4.61	1.29	7.31	4.98	1.30	7.75	4.96	1.31	8.19	5.28	1.33			
	25	5.43	4.07	1.39	6.05	4.09	1.41	6.25	4.45	1.42	6.66	4.46	1.43	6.87	4.82	1.44	7.28	4.80	1.45	7.69	5.11	1.47			
	30	5.08	3.93	1.52	5.66	3.96	1.55	5.85	4.30	1.56	6.24	4.32	1.57	6.43	4.66	1.58	6.82	4.64	1.60	7.20	4.94	1.61			
	35	4.74	3.80	1.65	5.28	3.82	1.68	5.46	4.15	1.68	5.82	4.17	1.70	6.00	4.50	1.71	6.36	4.48	1.73	6.72	4.77	1.74			
	40	4.50	3.68	1.79	5.01	3.70	1.81	5.18	4.02	1.82	5.52	4.04	1.84	5.69	4.36	1.85	6.03	4.34	1.87	6.37	4.63	1.89			
46	3.69	3.26	1.54	4.11	3.28	1.57	4.25	3.56	1.57	4.53	3.57	1.59	4.67	3.86	1.60	4.95	3.84	1.61	5.23	4.10	1.63				

4-2. Heating capacity

NOTE: Values mentioned in the table are calculated based on the maximum capacity.

■ Model: AUXG18KRLB

AFR	m ³ /h	1,050
-----	-------------------	-------

		Indoor temperature											
		°CDB		16		18		20		22		24	
		°CDB	°CWB	TC	IP	TC	IP	TC	IP	TC	IP	TC	IP
Outdoor temperature	-15	-16	5.05	1.66	4.93	1.70	4.81	1.73	4.69	1.76	4.57	1.80	
	-10	-11	5.69	1.77	5.56	1.80	5.42	1.84	5.28	1.88	5.15	1.91	
	-5	-7	6.33	1.87	6.18	1.91	6.03	1.95	5.88	1.99	5.73	2.03	
	0	-2	6.97	1.99	6.81	2.03	6.64	2.07	6.47	2.11	6.31	2.15	
	5	3	7.61	2.08	7.43	2.13	7.25	2.17	7.07	2.21	6.89	2.26	
	7	6	7.88	2.12	7.69	2.17	7.50	2.21	7.31	2.25	7.13	2.30	
	10	8	8.51	2.21	8.30	2.25	8.10	2.30	7.90	2.35	7.70	2.39	
	15	10	8.46	1.95	8.26	1.99	8.06	2.03	7.86	2.07	7.66	2.10	
	20	15	7.96	1.54	7.77	1.57	7.58	1.60	7.39	1.63	7.20	1.66	
	24	18	8.40	1.53	8.20	1.56	8.00	1.59	7.80	1.62	7.60	1.65	

■ Model: AUXG22KRLB

AFR	m ³ /h	1,050
-----	-------------------	-------

		Indoor temperature											
		°CDB		16		18		20		22		24	
		°CDB	°CWB	TC	IP	TC	IP	TC	IP	TC	IP	TC	IP
Outdoor temperature	-15	-16	5.60	2.10	5.46	2.15	5.33	2.19	5.20	2.23	5.06	2.28	
	-10	-11	6.14	2.19	6.00	2.23	5.85	2.28	5.70	2.33	5.56	2.37	
	-5	-7	6.70	2.27	6.54	2.31	6.38	2.36	6.22	2.41	6.06	2.45	
	0	-2	7.26	2.33	7.08	2.38	6.91	2.43	6.74	2.48	6.56	2.53	
	5	3	7.81	2.41	7.63	2.46	7.44	2.51	7.25	2.56	7.07	2.61	
	7	6	8.40	2.41	8.20	2.46	8.00	2.51	7.80	2.56	7.60	2.61	
	10	8	8.05	2.28	7.86	2.32	7.67	2.37	7.48	2.42	7.29	2.46	
	15	10	7.49	2.05	7.31	2.10	7.13	2.14	6.95	2.18	6.77	2.21	
	20	15	7.04	1.75	6.87	1.78	6.70	1.82	6.53	1.86	6.37	1.88	
	24	18	7.32	1.73	7.14	1.76	6.97	1.80	6.80	1.84	6.62	1.86	

5. Fan performance

5-1. Air velocity distributions

■ Model: AUXG18KRLB (4-way air outlet)

Measuring conditions	Fan speed	Operation mode
	HIGH	FAN

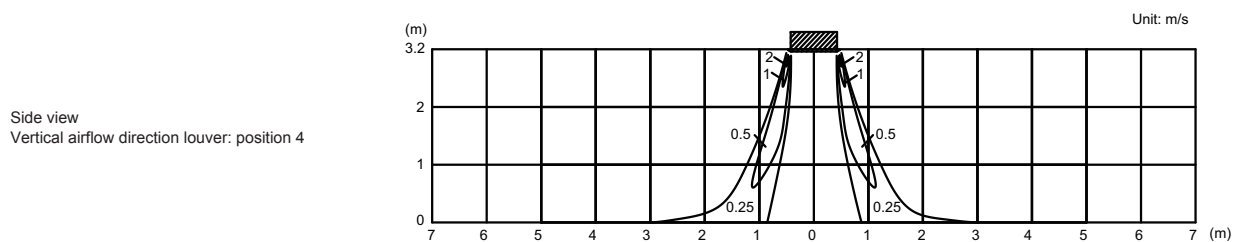
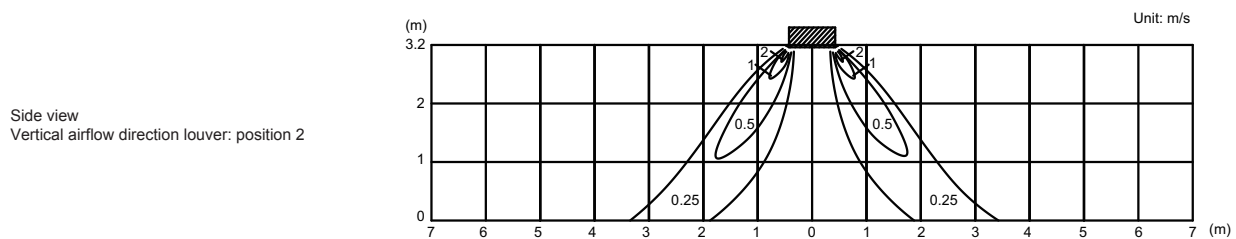
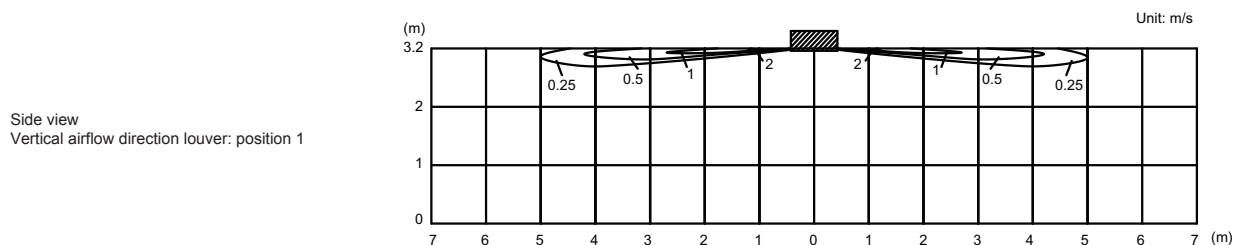
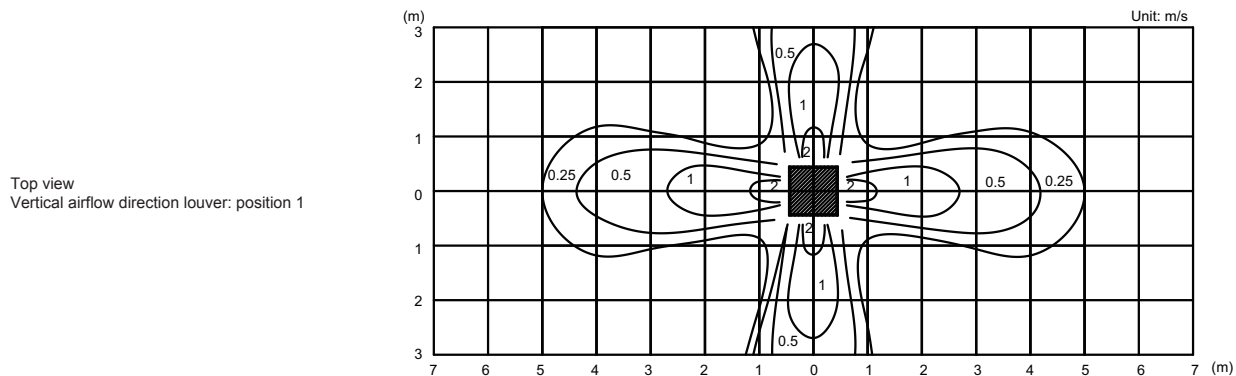

Model: AUXG22KRLB (4-way air outlet)

CASSETTE TYPE
AUXG18, 22KRLB

CASSETTE TYPE
AUXG18, 22KRLB

Measuring conditions	Fan speed	Operation mode
	HIGH	FAN

Top view
Vertical airflow direction louver: position 1

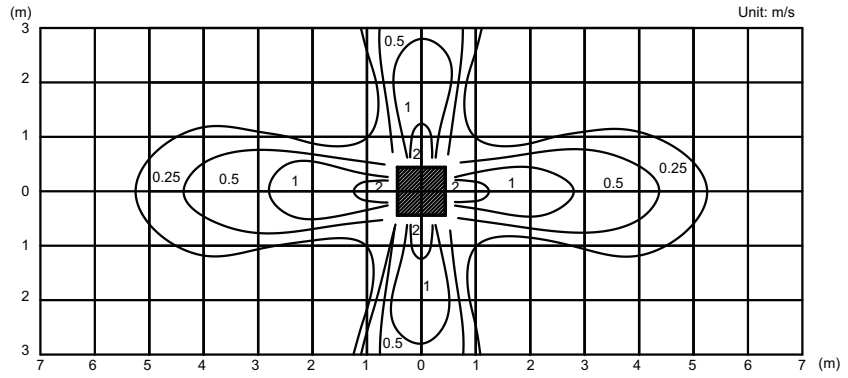

Side view
Vertical airflow direction louver: position 1

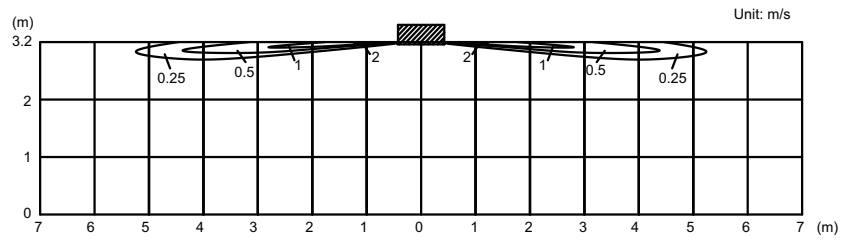

Side view
Vertical airflow direction louver: position 2

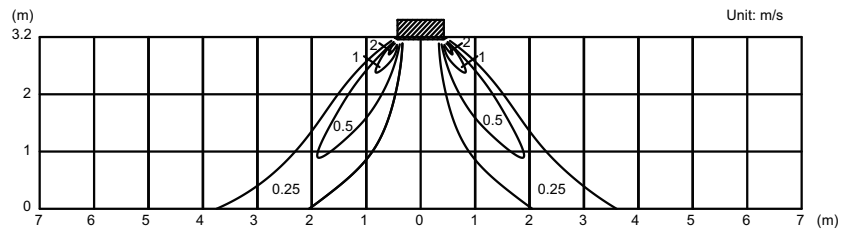

Side view
Vertical airflow direction louver: position 4

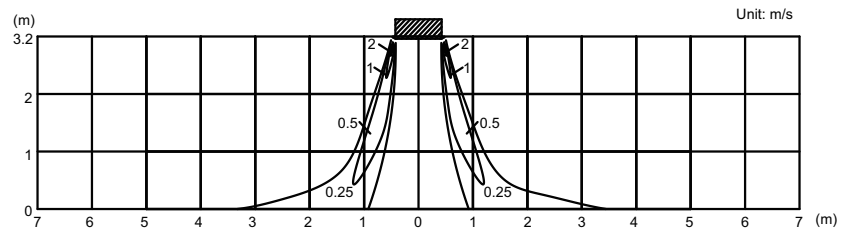

Model: AUXG18KRLB (3-way air outlet)

Measuring conditions	Fan speed	Operation mode
	HIGH	FAN

Top view
Vertical airflow direction louver: position 1

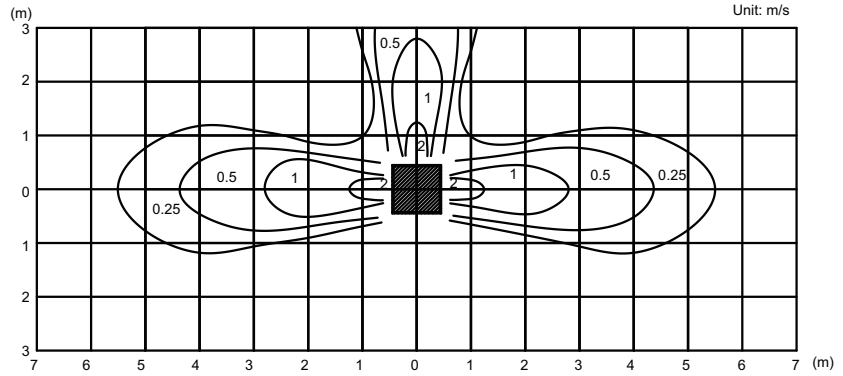

Side view
Vertical airflow direction louver: position 1

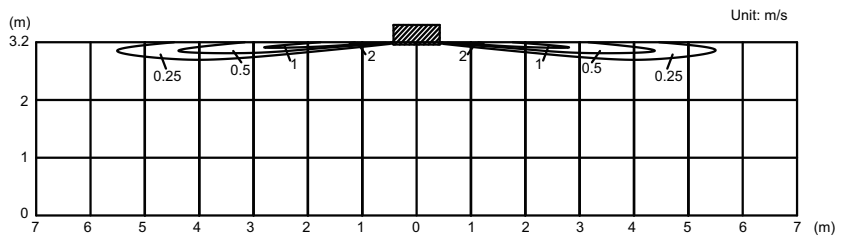

Side view
Vertical airflow direction louver: position 2

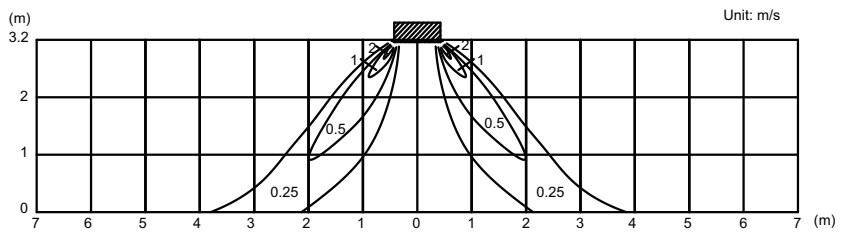

Side view
Vertical airflow direction louver: position 4

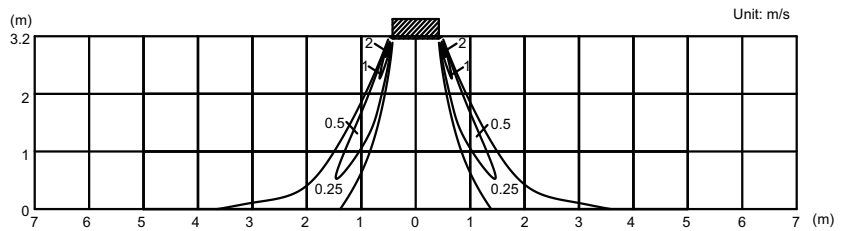

Model: AUXG22KRLB (3-way air outlet)

Measuring conditions	Fan speed	Operation mode
	HIGH	FAN

Top view
Vertical airflow direction louver: position 1

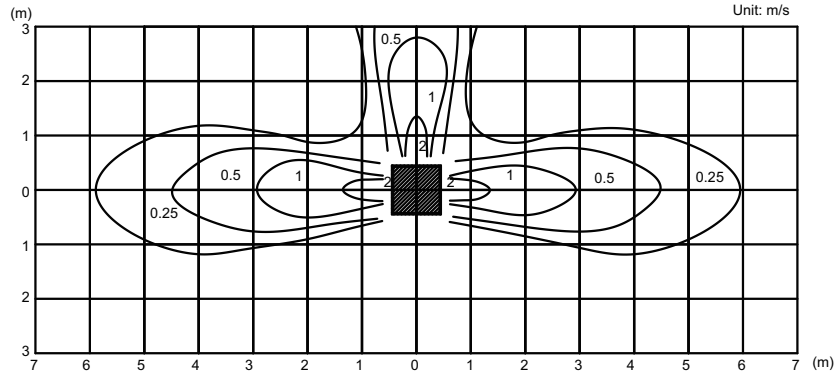

Side view
Vertical airflow direction louver: position 1

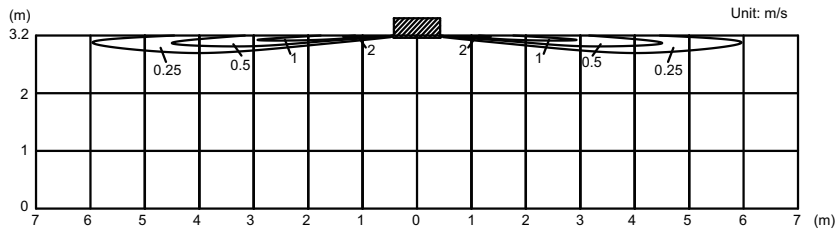

Side view
Vertical airflow direction louver: position 2

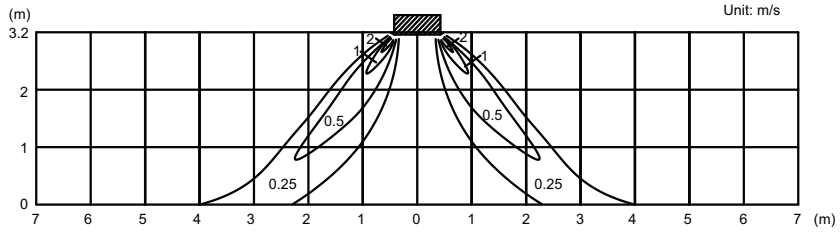

Side view
Vertical airflow direction louver: position 4

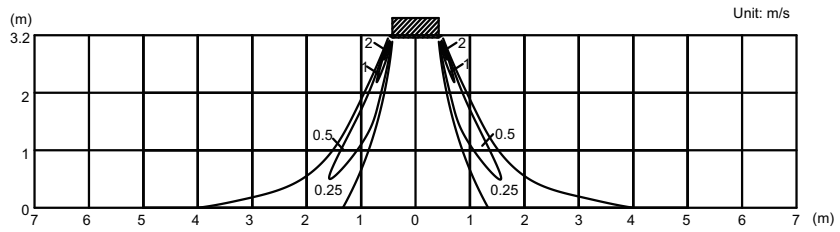

5-2. Airflow

■ Models: AUXG18KRLB and AUXG22KRLB (4-way air outlet)

● Cooling/Heating

Fan speed	Airflow	
HIGH	m ³ /h	1,050
	l/s	292
	CFM	618
MED	m ³ /h	960
	l/s	267
	CFM	565
LOW	m ³ /h	900
	l/s	250
	CFM	530
QUIET	m ³ /h	780
	l/s	217
	CFM	459

■ Models: AUXG18KRLB and AUXG22KRLB (3-way air outlet)

● Cooling/Heating

Fan speed	Airflow	
HIGH	m ³ /h	915
	l/s	254
	CFM	539
MED	m ³ /h	835
	l/s	232
	CFM	491
LOW	m ³ /h	785
	l/s	218
	CFM	462
QUIET	m ³ /h	680
	l/s	189
	CFM	400

5-3. Fresh-air characteristics

■ Airflow volume: static pressure of fresh-air intake characteristics

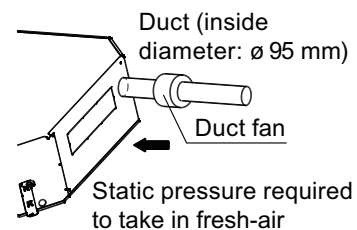
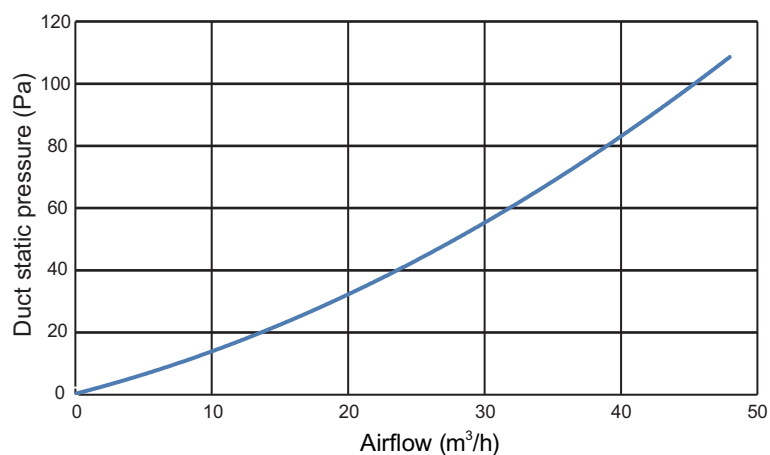

■ Installation

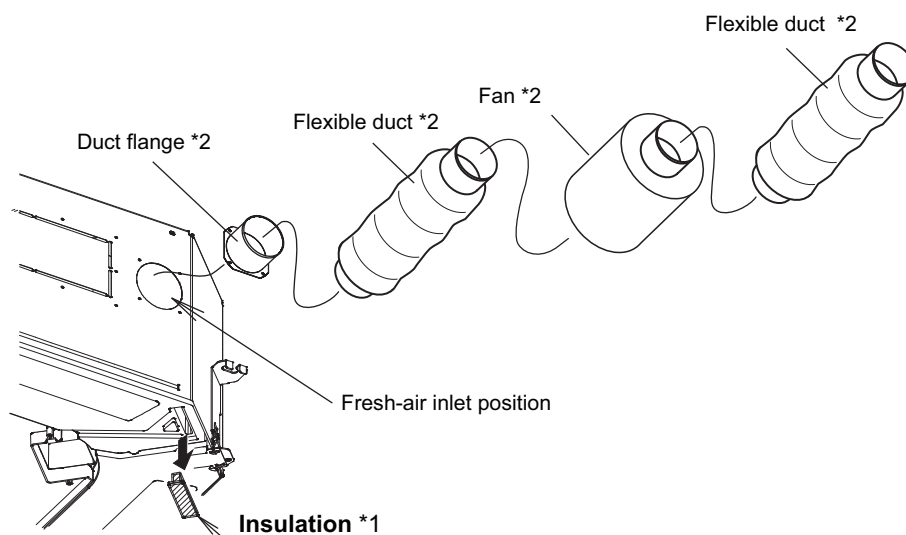

*1: In case of fresh-air intake, remove the insulation.

*2: Locally-purchased parts

For the fresh-air inlet position, refer to "[Dimensions](#)" on page 4.

5-4. Duct connection

■ Outlet air

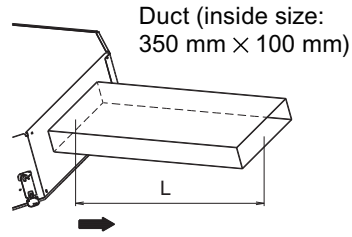

● Models: AUXG18KRLB and AUXG22KRLB

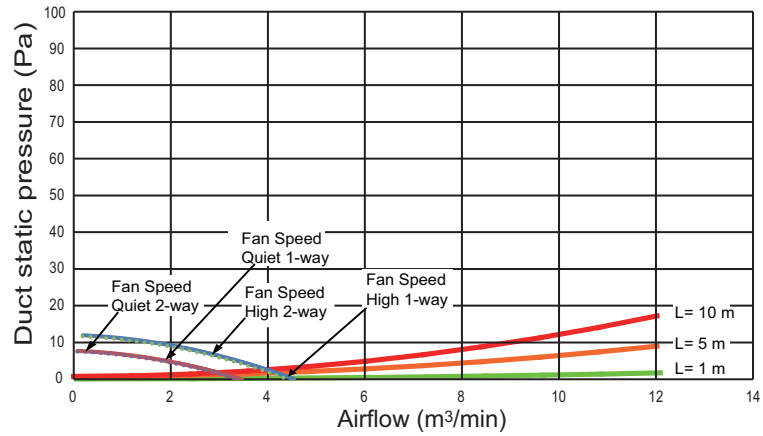

■ Precautions on air-outlet duct connection

- Connect the air-outlet duct to maximum 2 directions among the 4-duct connecting directions.

⚠ CAUTION

Do not connect ducts at 3 or more directions.

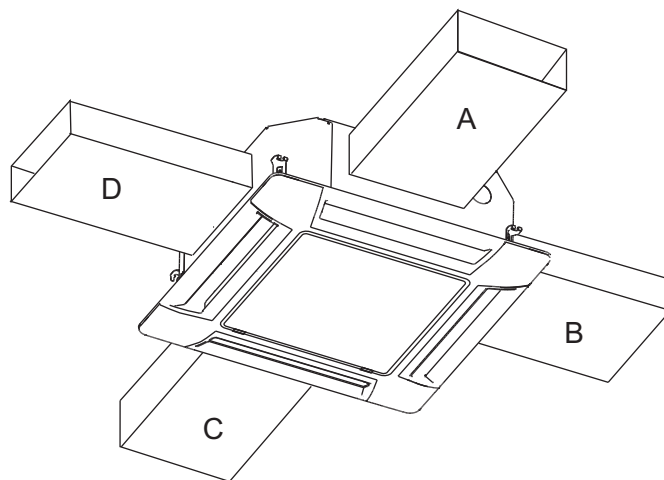

- When installing air-outlet duct in 2 directions, connect the ducts in a straight line.

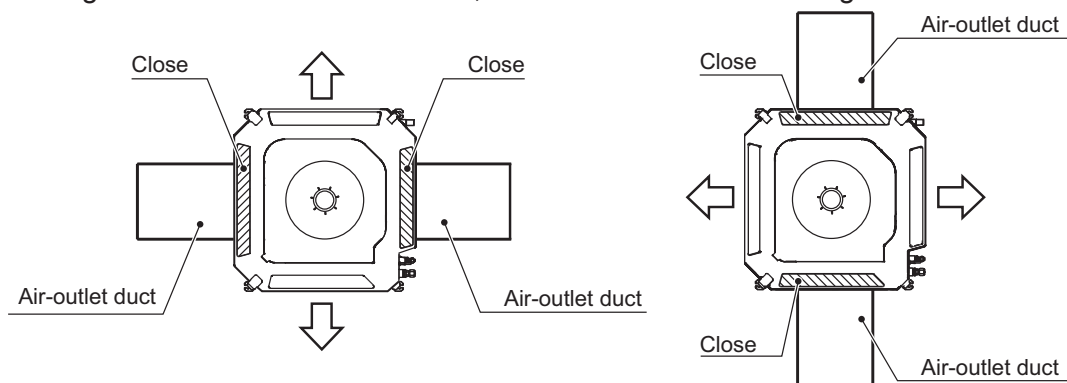

- Once the ducted direction is decided, be sure to close the outlet in the direction. Use optional Air outlet shutter plate (UTR-YDZK) to close the outlet.

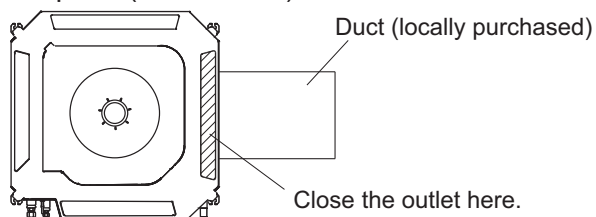

6. Operation noise (sound pressure)

6-1. Noise level curve

■ Models: AUXG18KRLB and AUXG22KRLB

● Cooling

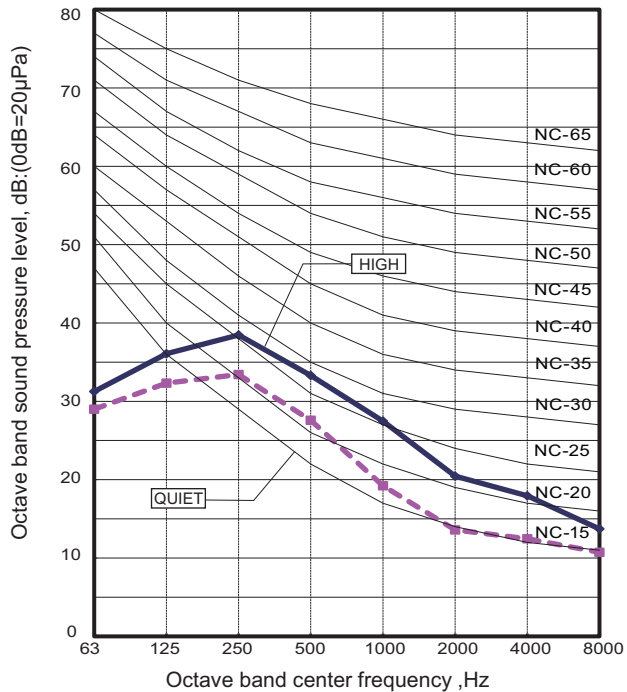

● Heating

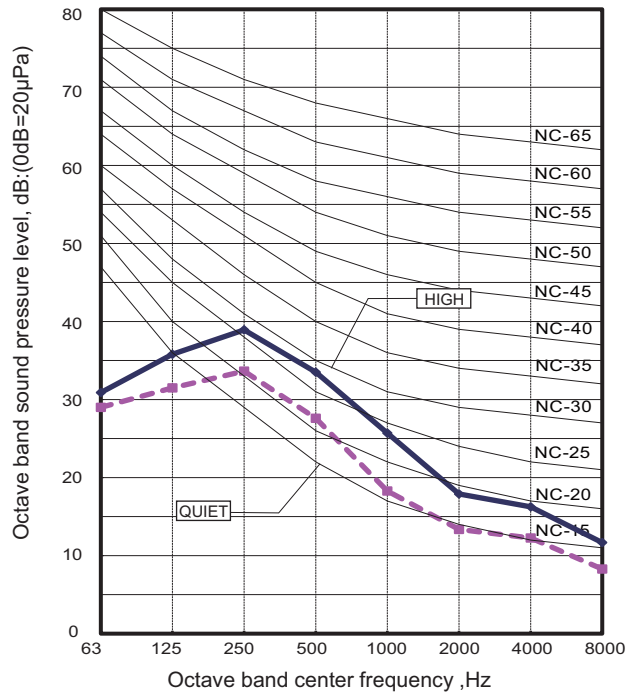

6-2. Sound level check point

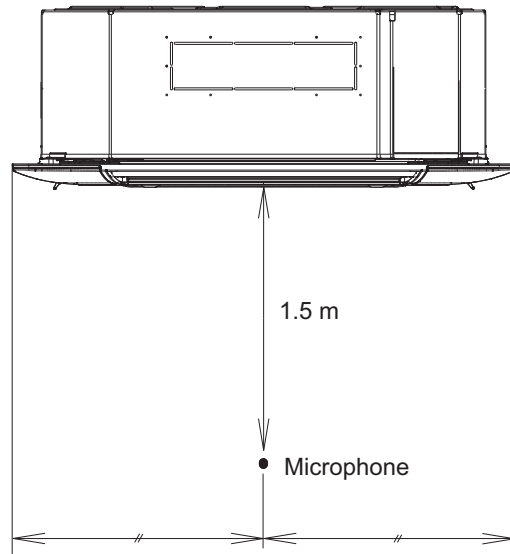
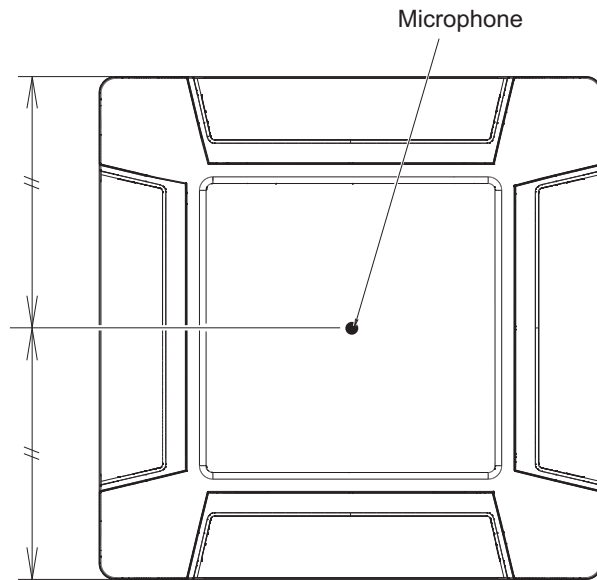

7. Safety devices

Type of protection	Protection form		Model	
			AUXG18KRLB	AUXG22KRLB
Circuit protection	Current fuse (PCB*)		250 V, 3.15 A	
Fan motor protection	Thermal protection program	Activate	125 ± 10 °C Fan motor stop	
		Reset	120 ± 10 °C Fan motor restart	

*: Printed Circuit Board

8. External input and output

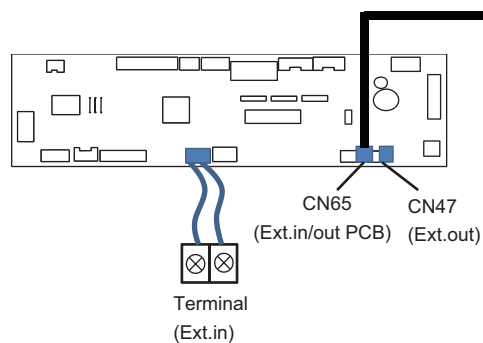

Fig. Indoor unit PCB

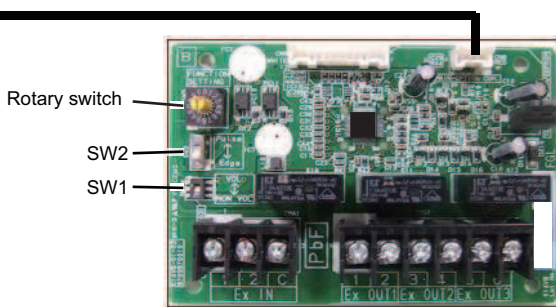

Fig. External input and output PCB

PCB	External input	External output	Connector	Input select	Input signal	External connect kit (Optional parts)
Indoor unit	Operation/Stop	-	Terminal	Dry contact	Edge	-
	-	Operation status	CN47	-	-	UTY-XWZXZG
		Error status				
		Indoor unit fan operation status				
External heater output						
External input and output (UTY-XCSX)	Operation/Stop	-	Input 1/ Input 2	Dry contact/ Apply voltage	Edge/ Pulse	-
	Forced thermostat off		Input 1		Edge	
	-	Operation status	Output 1	-	-	-
	Error status	Output 2				
	Indoor unit status	Output 3				
	External heater output					

8-1. External input

- "Operation/Stop" mode can be selected with function setting of indoor unit.
- A twisted pair cable (22AWG) should be used. Maximum length of cable is 150 m.
- The wire connection should be separate from the power cable line.

Indoor unit

Indoor unit functions such as Operation/Stop can be done by using indoor unit terminals.

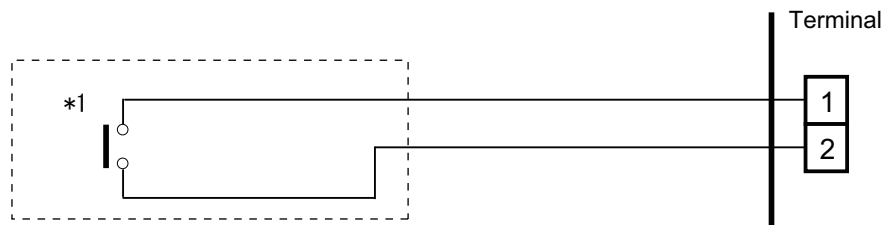

*1: The switch can be used on the following condition: DC 12 V to 24 V, 1 mA to 15 mA.

External input and output PCB

The indoor unit Operation/Stop can be set by using the input terminal on the PCB.

Input select

Use either one of these types of terminals according to the application. (Both types of terminals cannot be used simultaneously.)

- Dry contact

In case of internal power supply, set the slide switch of SW1 to "NON VOL" side.

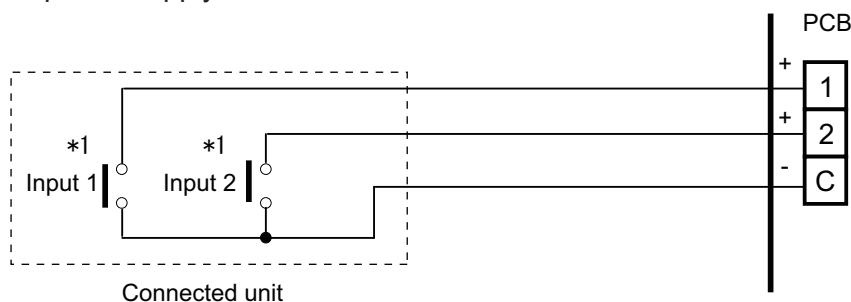

*1: The switches can be used on the following condition: DC 12 V to 24 V, 1 mA to 15 mA.

- Apply voltage

In case of external power supply, set the slide switch of SW1 to "VOL" side.

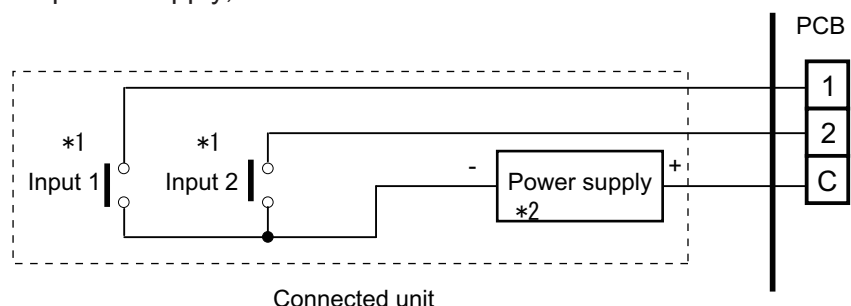

*1: The switches can be used on the following condition: DC 12 V to 24 V, 1 mA to 15 mA.

*2: Make the power supply DC 12 V to 24 V 10 mA or more.

8-2. External output

Use an external output cable with appropriate external dimension, depending on the number of cables to be installed.

Indoor unit

- A twisted pair cable (22AWG) should be used. Maximum length of cable is 25 m.
- Output voltage: High DC 12 V \pm 2 V, Low 0 V.
- Permissible current: 50 mA
- For details, refer to Chapter 8-3. "[Combination of external input and output](#)" on page 24.

When indicator, etc. are connected directly

Example: Function setting 60 is set to "00"

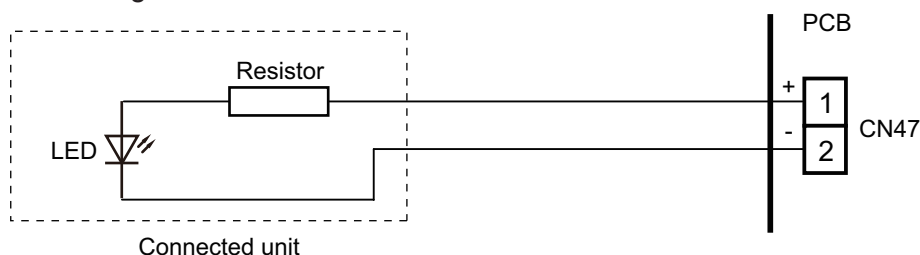

When connecting with a device equipped with a power supply

Example: Function setting 60 is set to "00"

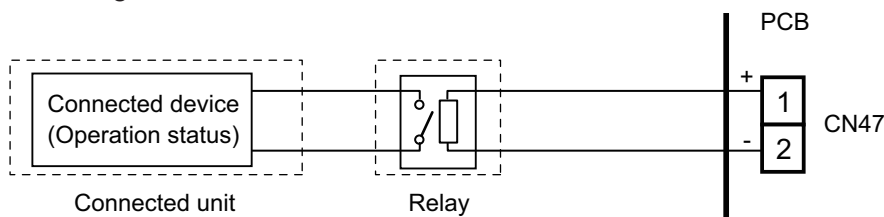

External input and output PCB

- A twisted pair cable (22AWG) should be used.
- Permissible voltage and current: DC 5 V to 30 V / 3 A, AC 30 V to 250 V / 3 A
- For details, refer to Chapter 8-3. "[Combination of external input and output](#)" on page 24.

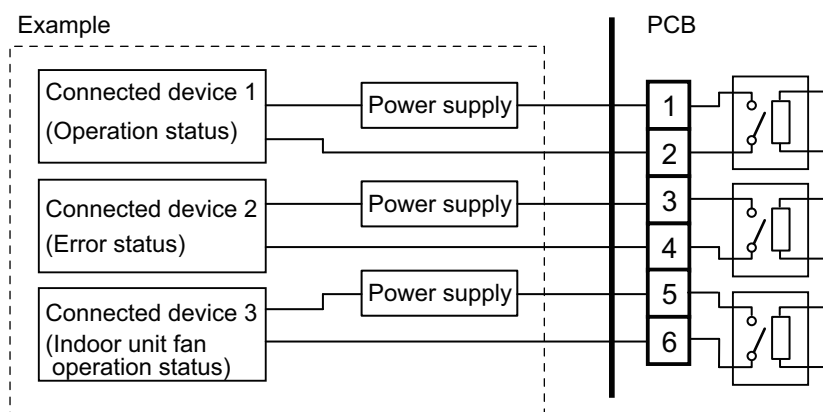

8-3. Combination of external input and output

By combining the function setting of the indoor unit and rotary switch setting of the External input and output PCB, you can select various combinations of functions.

Combination examples of external input and output are as follows:

Mode	Function setting	External input and output PCB (Rotary SW)	External input			
			Indoor unit Input	External input and output PCB		
				Terminal	Input 1	Input 2
0-1	60-00	1	Operation/Stop	Operation/Stop	Not available	Edge
				Operation	Stop	Pulse
0-2	60-00	2	Operation/Stop	Forced Thermostat OFF	Not available	Edge
1—8	60-01 to 60-08	3 - 9, A	(Setting prohibited)			
9	60-09	B	Operation/Stop	Forced Thermostat OFF	Not available	Edge
10	60-10	C	Operation/Stop	Forced Thermostat OFF	Not available	Edge
11	60-11	D	Operation/Stop	Forced Thermostat OFF	Not available	Edge

Mode	Function setting	External input and output PCB (Rotary SW)	External output			
			Indoor unit Output	External input and output PCB		
				CN47	Output 1	Output 2
0-1	60-00	1	Operation/Stop	Operation/Stop	Error status	Indoor unit fan operation status
0-2	60-00	2	Operation/Stop	Error status	Indoor unit fan operation status	External heater output
1—8	60-01 to 60-08	3 - 9, A	(Setting prohibited)			
9	60-09	B	Error status	Operation/Stop	Indoor unit fan operation status	External heater output
10	60-10	C	Indoor unit fan operation status	Operation/Stop	Error status	External heater output
11	60-11	D	External heater output	Operation/Stop	Indoor unit fan operation status	Error status

NOTE: Input of Operation/Stop depends on the setting of function setting 46.

00: Operation/Stop mode 1 (R.C. enabled)

01: (Setting prohibited)

02: Forced stop

03: Operation/Stop mode 2 (R.C. disabled)

Input signal type

- Indoor unit
Input signal type is only "Edge".

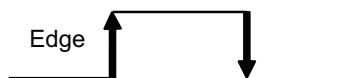

- External input and output PCB
The input signal type can be selected.

Signal type (edge or pulse) can be switched by the DIP switch 2 (SW2) on the External input and output PCB.

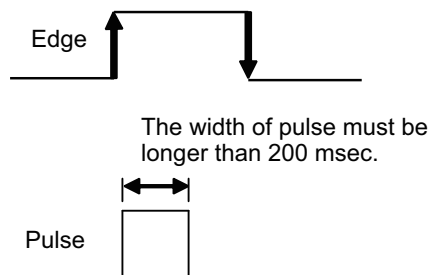

8-4. Details of function

■ Control input function

● When function setting is "Operation/Stop" mode 1

- In the case of "Edge" input

Function setting /	Rotary SW of External input and output PCB	External input		Input signal	Command
46-00	-	Input of indoor unit	Terminal	Off → On	Operation
				On → Off	Stop
	60-00 / 1	External input and output PCB	Input 1	Off → On	Operation
				On → Off	Stop

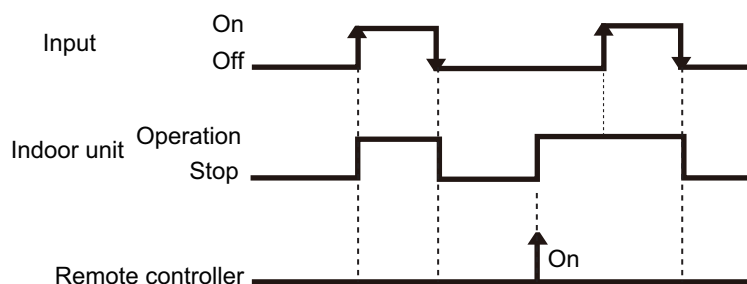

- In the case of "Pulse" input

Function setting /	Rotary SW of External input and output PCB	External input		Input signal	Command
46-00	60-00 / 1	External input and output PCB	Input 1	Pulse	Operation
			Input 2	Pulse	Stop

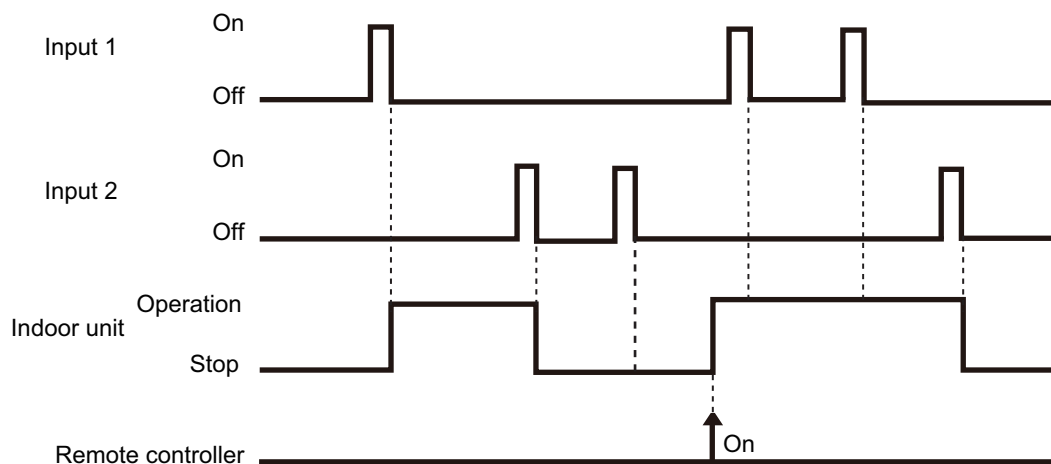

NOTES:

- The last command has priority.
- The indoor units within the same remote controller group operates in the same mode.

● When function setting is "Forced stop" mode

- In the case of "Edge" input

Function setting /	Rotary SW of External input and output PCB	External input		Input signal	Command
46-02	-	Input of indoor unit	Terminal	Off → On	Forced stop
				On → Off	Normal
	60-00 / 1	External input and output PCB	Input 1	Off → On	Forced stop
				On → Off	Normal

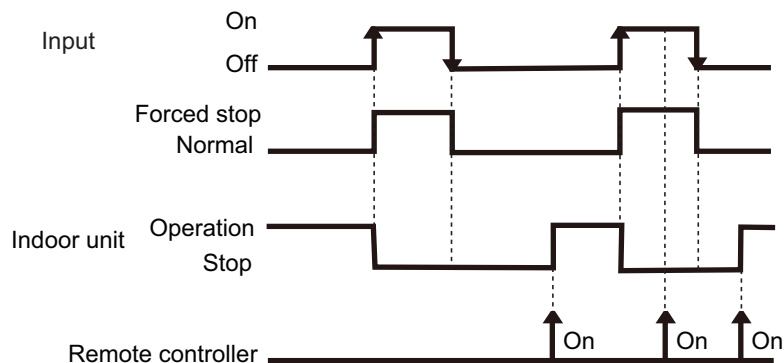

- In the case of "Pulse" input

Function setting /	Rotary SW of External input and output PCB	External input		Input signal	Command
46-02	60-00 / 1	External input and output PCB	Input 1	Pulse	Forced stop
			Input 2	Pulse	Normal

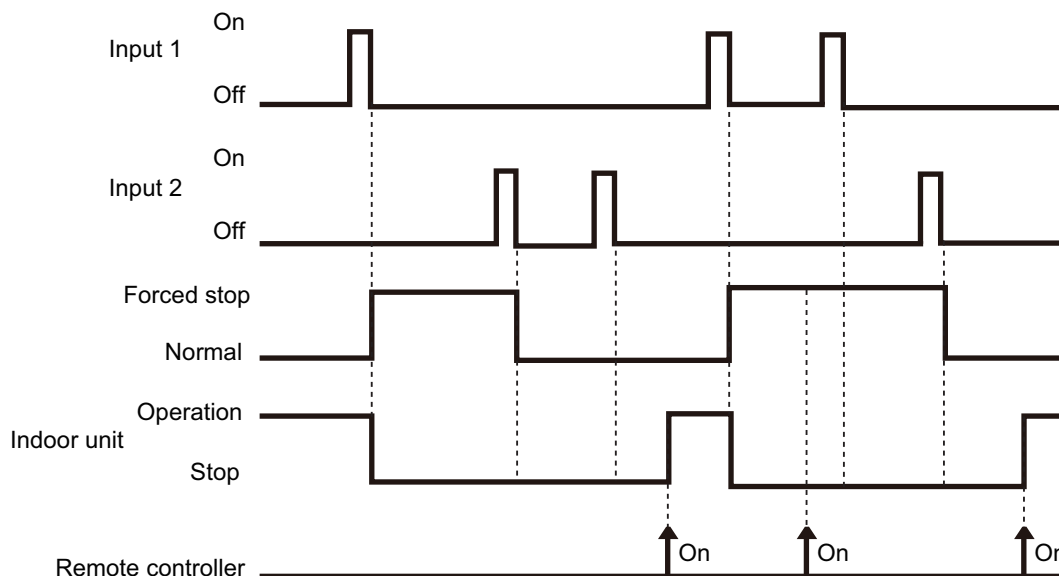

NOTES:

- When the forced stop is triggered, indoor unit stops and Operation/Stop operation by the remote controller is restricted.
- When forced stop function is used with forming a remote controller group, connect the same equipment to each indoor unit within the group.

● When function setting is "Operation/Stop" mode 2

- In the case of "Edge" input

Function setting /	Rotary SW of External input and output PCB	External input		Input signal	Command
46-03	-	Input of indoor unit	Terminal	Off → On	Operation
				On → Off	Stop (R.C. disabled)
	60-00 / 1	External input and output PCB	Input 1	Off → On	Operation
				On → Off	Stop (R.C. disabled)

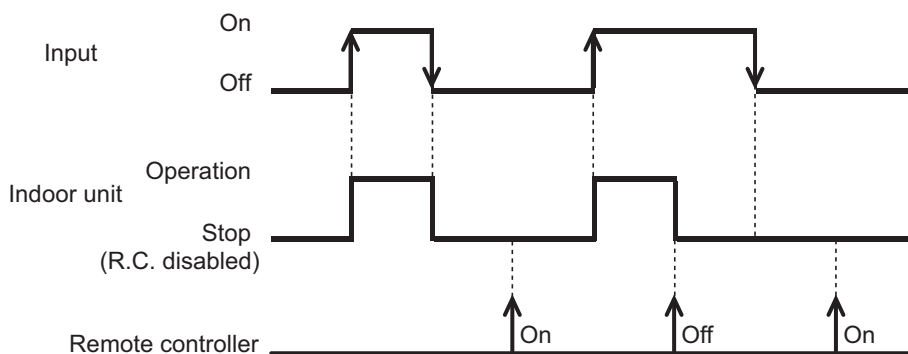

- In the case of "Pulse" input

Function setting /	Rotary SW of External input and output PCB	External input		Input signal	Command
46-03	60-00 / 1	External input and output PCB	Input 1	Pulse	Operation
			Input 2	Pulse	Stop (R.C. disabled)

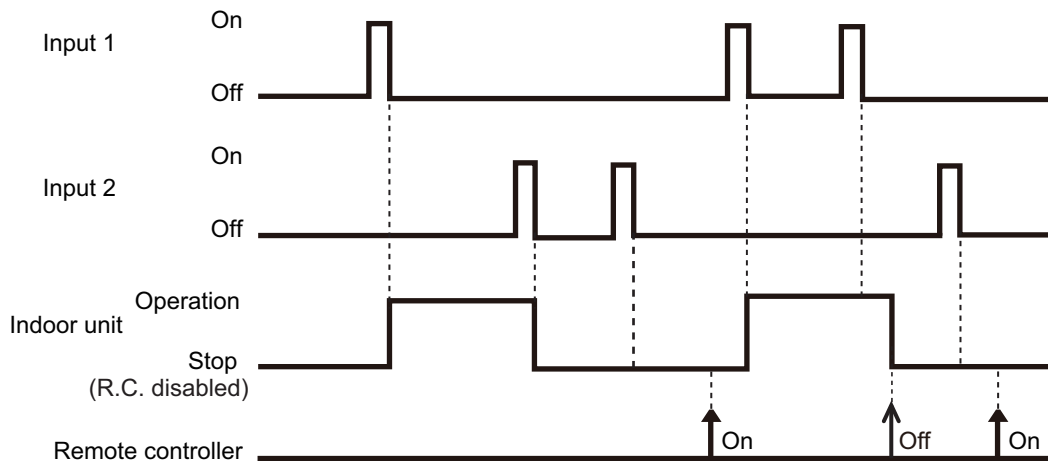

NOTES:

- When "Operation/Stop" mode 2 function is used with forming a remote controller group, connect the same equipment to each indoor unit within the group.

■ Forced thermostat off function

Function setting /	Rotary SW of External input and output PCB	External input		Input signal	Command
60-00 / 2 60-09 / B 60-10 / C 60-11 / D		External input and output PCB	Input 1	Off → On	Thermostat off
				On → Off	Normal operation

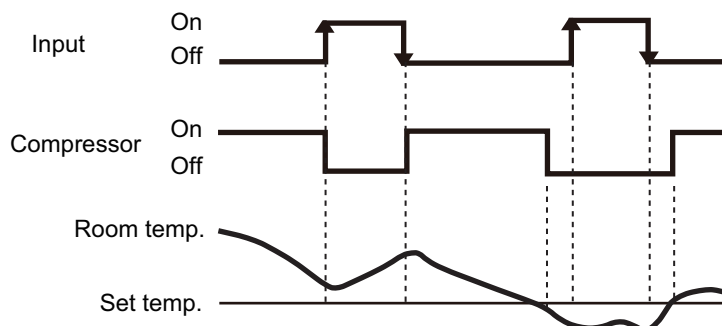

■ Control output function

Function setting /	Rotary SW of External input and output PCB	External output		Output signal	Command
60-00 / 1, 2		Output of indoor unit	CN47	Low → High High → Low	Operation Stop
60-00 / 1 60-09 / B 60-10 / C 60-11 / D		External input and output PCB	Output 1	Off → On	Operation
				On → Off	Stop

The output is low when the unit is stopped.

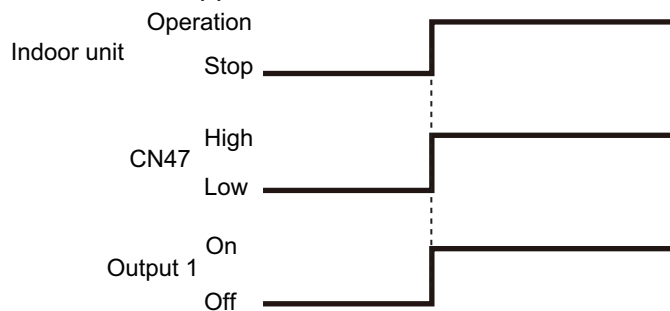

■ Error status

Function setting / Rotary SW of External input and output PCB	External output		Output signal	Command
60-09 / B	Output of indoor unit	CN47	Low → High	Error
			High → Low	Normal
60-00 / 2	External input and output PCB	Output 1	Off → On	Error
			On → Off	Normal
60-00 / 1 60-10 / C		Output 2	Off → On	Error
			On → Off	Normal
60-11 / D		Output 3	Off → On	Error
			On → Off	Normal

The output is ON when an error is generated for the indoor unit.

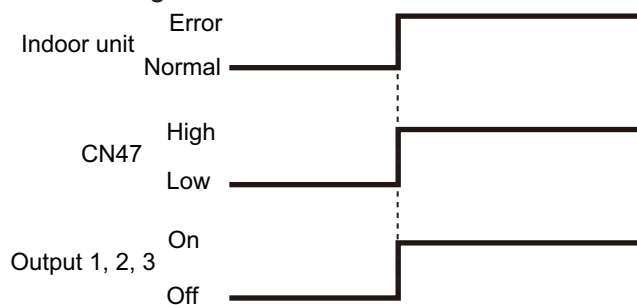

■ Indoor unit fan operation status

Function setting / Rotary SW of External input and output PCB	External output		Output signal	Command
60-10 / C	Output of indoor unit	CN47	Low → High	Fan run
			High → Low	Fan stop
60-00 / 2 60-09 / B 60-11 / D	External input and output PCB	Output 2	Off → On	Fan run
			On → Off	Fan stop
60-00 / 1		Output 3	Off → On	Fan run
			On → Off	Fan stop

Output signal	Condition
On Low → High	The indoor unit fan is operating.
Off High → Low	The fan is stopped or during cold air prevention. During thermostat off when in dry mode operation.

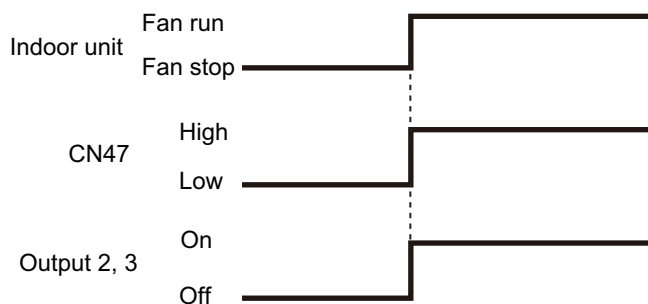

External heater output

Function setting / Rotary SW of External input and output PCB	External output	Output signal	Command
60-11 / D	Output of indoor unit CN47	Low → High	Heater on
		High → Low	Heater off
60-00 / 2 60-09 / B 60-10 / C	External input and output PCB Output 3	Off → On	Heater on
		On → Off	Heater off

Output signal	Condition
Low → High Off → On	Heater turns on as shown in diagram of heating temperature
High → Low On → Off	Heater turns off as shown in diagram of heating temperature <ul style="list-style-type: none"> • Other than Heating mode • Error occurred • Forced thermo off • Fan stop protection

Specifications of the signal output performance are as shown as follows:

Example: When set temperature (T_s) is set at 22 °C;

- And room temperature (T_r) increase above 12 °C, signal output is on.
- And T_r increase above 21 °C, signal output is off.
- And T_r decrease below 19 °C, signal output is on.
- And T_r decrease below 10 °C, signal output is off.

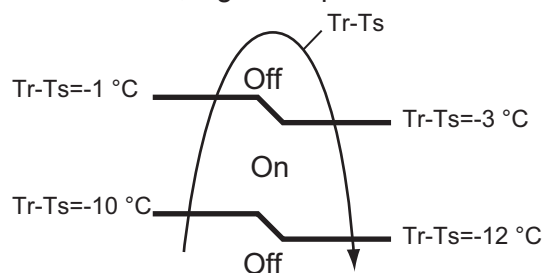

The output also turns off in defrost operation.

9. Function settings

To adjust the functions of this product according to the installation environment, various types of function settings are available.

NOTE: Incorrect settings can cause a product malfunction.

9-1. Function settings on indoor unit

By using some components on the PCB, you can change the function settings.

■ Component location

Components on the indoor unit main PCB used for the function settings are located as shown in the following figure.

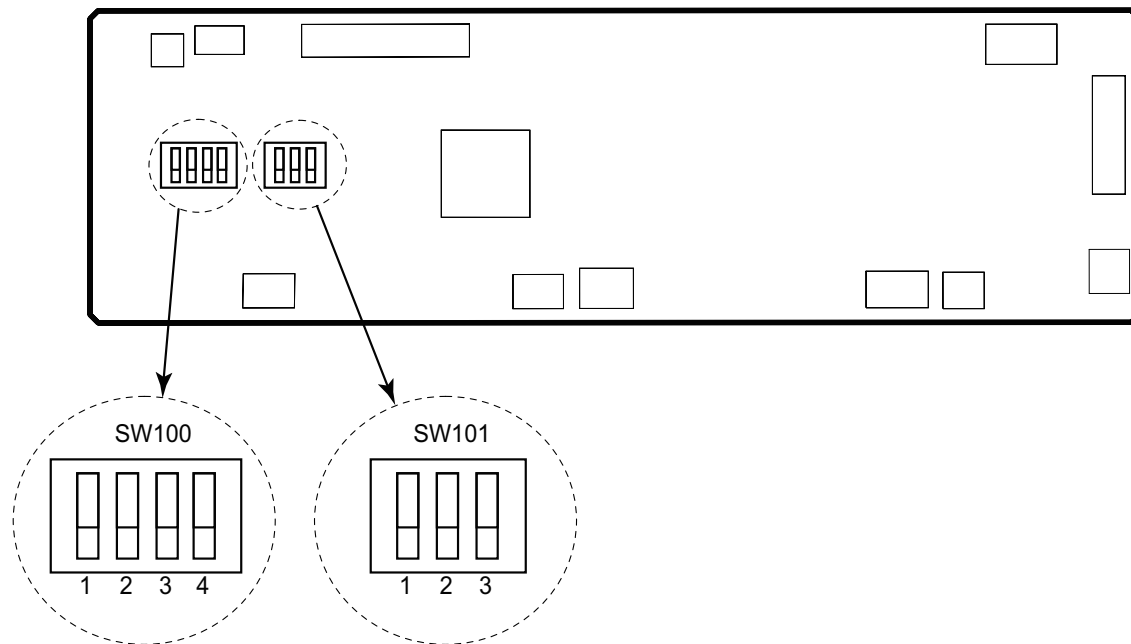

■ DIP switch setting

- **SW100: Remote controller address setting**

NOTE: Because this setting is normally done automatically when 2-core wired remote controller is installed, setting is unnecessary.

Multiple indoor units can be operated by using one wired remote controller.
Set the unit number of each indoor unit.

Remote controller address	DIP switch number				Factory setting
	1	2	3	4	
00	OFF	OFF	OFF	OFF	◆
01	ON	OFF	OFF	OFF	
02	OFF	ON	OFF	OFF	
03	ON	ON	OFF	OFF	
04	OFF	OFF	ON	OFF	
05	ON	OFF	ON	OFF	
06	OFF	ON	ON	OFF	
07	ON	ON	ON	OFF	
08	OFF	OFF	OFF	ON	
09	ON	OFF	OFF	ON	
10	OFF	ON	OFF	ON	
11	ON	ON	OFF	ON	
12	OFF	OFF	ON	ON	
13	ON	OFF	ON	ON	
14	OFF	ON	ON	ON	
15	ON	ON	ON	ON	

NOTES:

- When connecting Polar 3-core wired remote controller, set the remote controller address in the order of 0, 1, 2,, and 15.
- When different type of indoor units (such as wall-mounted type and cassette type, cassette type and duct type, or other combinations) are connected using group control system, some functions may no longer be available.

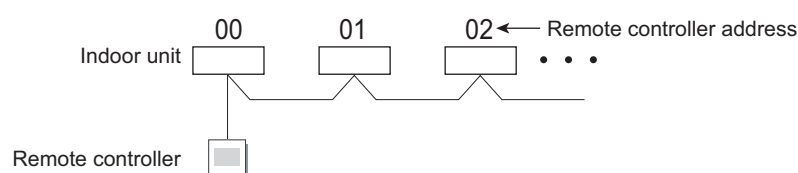

- **SW101: Setting change prohibited**

9-2. Function settings by using remote controller

Some function settings can be changed on the remote controller. After confirming the setting procedure and the content of each function setting, select appropriate functions for your installation environment.

■ Setting procedure by using remote controller

Remote controller is not attached for this product. For details of the installing remote controller, refer to following information.

- Overview information: Operating manual of the remote controller
- Setting procedure: Installation manual of the remote controller

■ Contents of function setting

Each function setting listed in this section is adjustable in accordance with the installation environment.

NOTE: Setting will not be changed if invalid numbers or setting values are selected.

● Function setting list

	Function no.	Functions
1)	11	Filter sign
2)	20	Ceiling height
3)	22	Outlet directions
4)	23	Vertical airflow direction range control
5)	30/31	Room temperature control for indoor unit sensor
6)	35/36	Room temperature control for wired remote controller sensor
7)	40	Auto restart
8)	42	Room temperature sensor switching
9)	44	Remote controller custom code
10)	46	External input control
11)	48	Room temperature sensor switching (Aux.)
12)	49	Indoor unit fan control for energy saving for cooling
13)	60	Switching functions for external output terminal

1) Filter sign

Select appropriate intervals for displaying the filter sign on the indoor unit according to the estimated amount of dust in the air of the room.

If the indication is not required, select "No indication" (03).

Function number	Setting value	Setting description	Factory setting
11	00	Standard (2,500 hours)	
	01	Long interval (4,400 hours)	
	02	Short interval (1,250 hours)	
	03	No indication	◆

2) Ceiling height

Select the appropriate ceiling height according to the place of installation.

Function number	Setting value	Setting description	Factory setting
20	00	Standard	◆
	01	High ceiling	
	02	Low ceiling	

For the specific height for each setting value, refer to "Installation space" in Chapter 2. "Dimensions" on page 4.

In case of cassette type models:

The ceiling height values are for the 4-way outlet. Do not change this setting in the 3-way outlet mode.

3) Outlet directions

Select the appropriate number of outlet directions according to the installation conditions.

Function number	Setting value	Setting description	Factory setting
22	00	4-way	◆
	01	3-way	

4) Vertical airflow direction range control

To prevent draft, change the setting to "Upward" (01).

Note that the airflow in certain usage conditions may leave the ceiling dirty. In such cases, the use of the optional Panel spacer is recommended.

Function number	Setting value	Setting description	Factory setting
23	00	Standard	◆
	01	Upward	

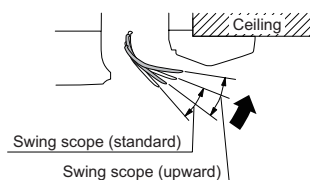

5) Room temperature control for indoor unit sensor

Depending on the installed environment, correction of the room temperature sensor may be required. Select the appropriate control setting according to the installed environment.

The temperature correction values show the difference from the Standard setting "00" (manufacturer's recommended value).

Function number		Setting value	Setting description	Factory setting	
30 (For cooling)	31 (For heating)	00	Standard setting	◆	
		01	No correction 0.0 °C		
		02	-0.5 °C	More cooling Less heating	
		03	-1.0 °C		
		04	-1.5 °C		
		05	-2.0 °C		
		06	-2.5 °C		
		07	-3.0 °C		
		08	-3.5 °C		
		09	-4.0 °C		
		10	+0.5 °C	Less cooling More heating	
		11	+1.0 °C		
		12	+1.5 °C		
		13	+2.0 °C		
		14	+2.5 °C		
		15	+3.0 °C		
		16	+3.5 °C		
17	+4.0 °C				

6) Room temperature control for wired remote controller sensor

Depending on the installed environment, correction of the wire remote temperature sensor may be required. Select the appropriate control setting according to the installed environment.

To change this setting, set Function 42 to Both "01".

Ensure that the Thermo Sensor icon is displayed on the remote controller screen.

Function number		Setting value	Setting description	Factory setting	
35 (For cooling)	36 (For heating)	00	Standard setting	◆	
		01	No correction 0.0°C		
		02	-0.5 °C	More cooling Less heating	
		03	-1.0 °C		
		04	-1.5 °C		
		05	-2.0 °C		
		06	-2.5 °C		
		07	-3.0 °C		
		08	-3.5 °C		
		09	-4.0 °C		
		10	+0.5 °C	Less cooling More heating	
		11	+1.0 °C		
		12	+1.5 °C		
		13	+2.0 °C		
		14	+2.5 °C		
		15	+3.0 °C		
		16	+3.5 °C		
17	+4.0 °C				

7) Auto restart

Enables or disables automatic restart after a power interruption.

Function number	Setting value	Setting description	Factory setting
40	00	Enable	◆
	01	Disable	

NOTE: Auto restart is an emergency function such as for power outage etc. Do not attempt to use this function in normal operation. Be sure to operate the unit by remote controller or external device.

8) Room temperature sensor switching

(Only for wired remote controller)

When using the wired remote controller temperature sensor, change the setting to "Both" (01).

Function number	Setting value	Setting description	Factory setting
42	00	Indoor unit	◆
	01	Both	

00: Sensor on the indoor unit is active.

01: Sensors on both indoor unit and wired remote controller are active.

NOTE: Remote controller sensor must be turned on by using the remote controller.

9) Remote controller custom code

(Only for wireless remote controller)

The indoor unit custom code can be changed. Select the appropriate custom code.

Function number	Setting value	Setting description	Factory setting
44	00	A	◆
	01	B	
	02	C	
	03	D	

10) External input control

"Operation/Stop" mode or "Forced stop" mode can be selected.

Function number	Setting value	Setting description	Factory setting
46	00	Operation/Stop mode 1	◆
	01	(Setting prohibited)	
	02	Forced stop mode	
	03	Operation/Stop mode 2	

11) Room temperature sensor switching (Aux.)

To use the temperature sensor on the wired remote controller only, change the setting to "Wired remote controller" (01).

This function will only work if the function setting 42 is set at "Both" (01).

When the setting value is set to "Both" (00), more suitable control of the room temperature is possible by setting function setting 30 and 31 too.

Function number	Setting value	Setting description	Factory setting
48	00	Both	◆
	01	Wired remote controller	

12) Indoor unit fan control for energy saving for cooling

Enables or disables the power-saving function by controlling the indoor unit fan rotation when the outdoor unit is stopped during cooling operation.

Function number	Setting value	Setting description	Factory setting
49	00	Disable	
	01	Enable	
	02	Remote controller	◆

00: When the outdoor unit is stopped, the indoor unit fan operates continuously following the setting on the remote controller.

01: When the outdoor unit is stopped, the indoor unit fan operates intermittently at a very low speed.

02: Enable or disable this function by remote controller setting.

NOTES:

- As the factory setting, this setting is initially activated.
- Set to "00" or "01" when connecting a remote controller that cannot set the Fan control for energy saving function or connecting a network converter.
To confirm if the remote controller has this setting, refer to the operating manual of each remote controller.







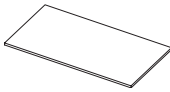
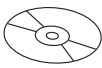
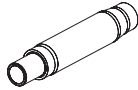

13) Switching functions for external output terminal

Functions of the external output terminal can be switched. For details, refer to "External input and output".

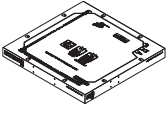
Function number	Setting value	Setting description	Factory setting
60	00	Operation status	◆
	01—08	(Setting prohibited)	
	09	Error status	
	10	Indoor unit fan operation status	
	11	External heater	

10. Accessories

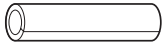
10-1. Models: AUXG18KRLB and AUXG22KRLB

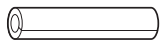
Part name	Exterior	Q'ty	Part name	Exterior	Q'ty
Operating manual		1	Insulation		1
Operating manual (CD-ROM)		1	Drain hose		1
Installation manual		1	Hose band		1
Template (Carton top)		1	Drain hose heat insulation		1
Washer		8	Cable tie (large)		4
Coupler heat insulation (large)		1	Cable tie (small)		2
Coupler heat insulation (small)		1			

11. Optional parts

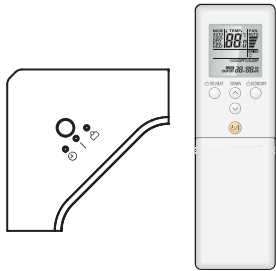

11-1. Controllers

Exterior	Part name	Model name	Summary
	Wired remote controller	UTY-RNRYZ*	Easy finger touch operation with LCD panel. Backlit LCD enables easy operation in a dark room. Wire type: Non-polar 2-wire
	Wired remote controller	UTY-RLRY	High visibility and easy operation. Room temperature can be accurately controlled using the built-in thermo sensor. Wire type: Non-polar 2-wire
	Wired remote controller	UTY-RVNYM	Large and full-dot liquid crystal screen, wide and large keys easy to press, user-intuitive arrow key. Wire type: Polar 3-wire
	Wired remote controller	UTY-RNNYM	Room temperature can be controlled by detecting the temperature accurately with built-in thermo sensor. Wire type: Polar 3-wire
	Simple remote controller	UTY-RSRY	Compact remote controller concentrates on the basic functions such as Start/Stop, fan control, temperature setting, and operation mode. Wire type: Non-polar 2-wire
	Simple remote controller	UTY-RHRY	Compact remote controller concentrates on the basic functions such as Start/Stop, fan control, and temperature setting. Wire type: Non-polar 2-wire
	Simple remote controller	UTY-RSNYM	Compact remote controller concentrates on the basic functions such as Start/Stop, fan control, temperature setting, and operation mode. Wire type: Polar 3-wire



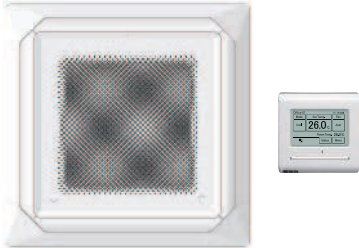

Exterior	Part name	Model name	Summary
	IR receiver kit with wireless remote controller	UTY-LBTYC	Unit control is performed by wireless remote controller.

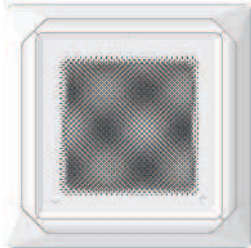

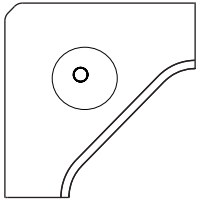
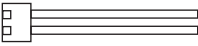

NOTE: Available functions may differ by the remote controller. For details, refer to the operation manual.

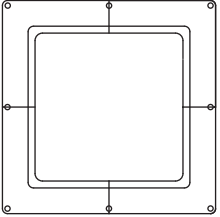
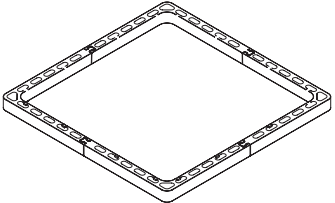
11-2. Cassette grille

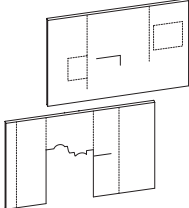
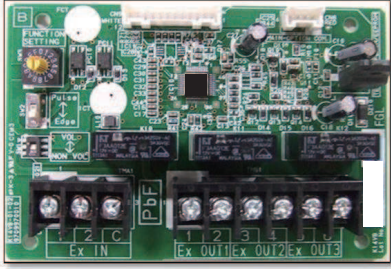
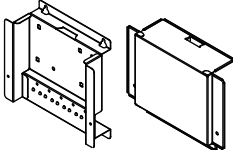
Exterior	Part name	Model name	Summary
	Cassette grille	UTG-UKYA-W	This cassette grille to blow airflow in 360° direction by unique seamless airflow louver design. Wired remote controller (UTY-RNRYZ*) is included.
	Cassette grille	UTG-UKYA-B	This cassette grille to blow airflow in 360° direction by unique seamless airflow louver design. Black color model.
	Cassette grille	UTG-UKYC-W	This cassette grille to blow airflow in 360° direction by unique seamless airflow louver design.

11-3. Others

Exterior	Part name	Model name	Summary
	Human sensor kit	UTY-SHZXC	For circular flow cassette type.
	External connect kit	UTY-XWZXZG	Use to connect with various peripheral devices and air conditioner PCB. For control output port.
	Air outlet shutter plate	UTR-YDZK	Installed at the air outlet when 3-directions mode is performed.
	Wide panel	UTG-AKXA-W	Hides the gap between the ceiling hole and the cassette grille.
	Panel spacer	UTG-BKXA-W	If there is not enough height in the ceiling space, by inserting this spacer between the cassette grille and the ceiling surface, the height of the unit body goes into the ceiling space become 50-mm lower.
	Fresh-air intake kit	UTZ-VXRA	By attaching Fresh-air intake kit to the indoor unit, it can be taken in fresh air of up to 10% of "high" air volume of the indoor unit.
	Insulation for high humidity	UTZ-KXRA	Install when the under-roof condition is expected to be the humidity of over 80% and the temperature of over 30 °C.
	External input and output PCB	UTY-XCSX	Use to connect with external devices and air conditioner PCB.
	External input and output PCB box	UTZ-GXRA	For installing the External input and output PCB.

Exterior	Part name	Model name	Summary
	Wireless LAN adapter	UTY-TFSXZ1	Remotely manage an air conditioning system using mobile devices such as smartphones and tablets. For connection indoor unit with UART interface.
	Modbus converter	UTY-VMSX	For connection between indoor unit with UART interface and a Modbus open network.
	KNX converter	UTY-VKSX	For connection between indoor unit with UART interface and a KNX open network.
	External switch controller	UTY-TERX	Air conditioner switching can be controlled by connecting other external sensor switches.

NOTE: Combined use of following optional parts and Wireless LAN adapter (UTY-TFSXZ1) is not allowed.

- External input and output PCB (UTY-XCSX)
- Modbus converter
- KNX converter

Part 2. OUTDOOR UNIT

SINGLE TYPE:

AOYG18KBTB

AOYG22KBTB

1. Specifications

OUTDOOR UNIT
AOYG18, 22KBTB

OUTDOOR UNIT
AOYG18, 22KBTB

Type				Inverter heat pump				
Model name				AOYG18KBTB		AOYG22KBTB		
Power supply				230 V ~ 50 Hz				
Available voltage range				198—264 V				
Starting current				A		7.1		
Fan	Airflow rate	Cooling	m ³ /h	2,160		2,240		
		Heating		1,830		1,960		
	Type × Q'ty		Propeller fan × 1					
	Motor output		W		49			
Sound pressure level *1		Cooling	dB (A)	50		51		
		Heating		50		51		
Sound power level		Cooling	dB (A)	62		63		
		Heating		62		63		
Heat exchanger type	Dimensions (H × W × D)		mm	588 × 881 × 18.19		588 × 881 × 18.19		
				588 × 851 × 18.19		588 × 851 × 18.19		
	Fin pitch		1.3					
	Rows × Stages		2 × 28		2 × 28			
	Pipe type		Copper tube					
	Fin type		Type (Material)		Aluminum			
		Surface treatment		PC fin				
Compressor	Type × Q'ty		W		DC Twin rotary × 1			
	Motor output		900		1,060			
Refrigerant	Type (Global warming potential)		R32 (675)					
	Charge		g		1,020		1,250	
Refrigerant oil	Type		FW68S		RmM68AF			
	Amount		cm ³		350		400	
Enclosure	Material		Steel sheet					
	Color		Beige Approximate color of Munsell 10YR 7.5/1.0					
Dimensions (H × W × D)	Net		mm		632 × 799 × 290			
	Gross		692 × 940 × 375					
Weight	Net		kg		36		38	
	Gross		40		42			
Connection pipe	Size	Liquid	mm (in)	Ø 6.35 (Ø 1/4)				
		Gas		Ø 12.70 (Ø 1/2)				
	Method		Flare					
	Pre-charge length		20					
	Max. length		m		30			
Max. height difference		20		25				
Operation range		Cooling	°C	-15 to 46				
		Heating		-15 to 24				
Drain hose	Material		PP					
	Size		mm		Ø 13.0 (I. D.), Ø 16.0 to Ø 16.8 (O. D.)			
NOTES:								
<ul style="list-style-type: none"> • Specifications are based on the following conditions: <ul style="list-style-type: none"> – Cooling: Indoor temperature of 27 °CDB/19 °CWB, and outdoor temperature of 35 °CDB/24 °CWB. – Heating: Indoor temperature of 20 °CDB/15 °CWB, and outdoor temperature of 7 °CDB/6 °CWB. – Pipe length: 5 m, Height difference: 0 m. • Protective function might work when using it outside the operation range. • *1: Sound pressure level <ul style="list-style-type: none"> – Measured values in manufacturer's anechoic chamber. – Because of the surrounding sound environment, the sound levels measured in actual installation conditions might be higher than the specified values here. 								

2. Dimensions

2-1. Models: AOYG18KBTB and AOYG22KBTB

Unit: mm

OUTDOOR UNIT
AOYG18, 22KBTB

OUTDOOR UNIT
AOYG18, 22KBTB

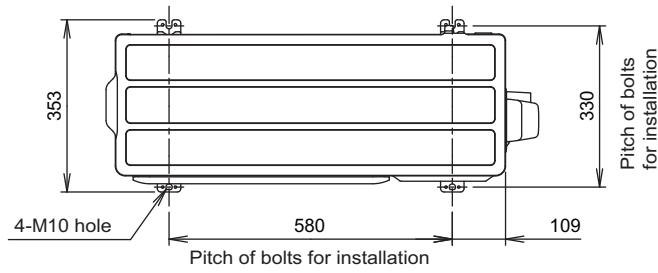

Top view

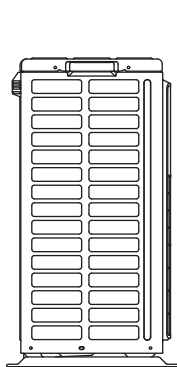

Side view

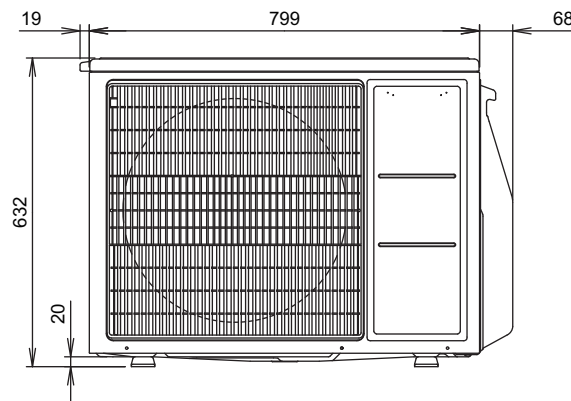

Front view

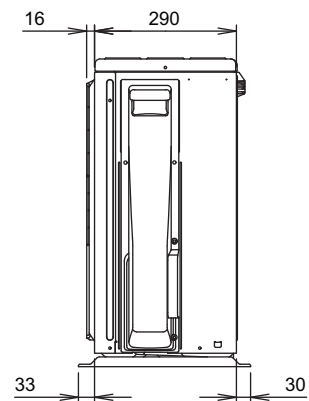

Side view

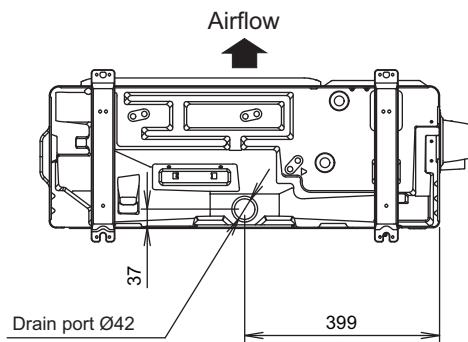

Bottom view

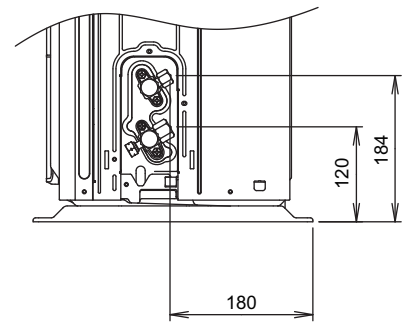

Side view (Valve part)

3. Installation space

3-1. Models: AOYG18KBTB and AOYG22KBTB

■ Space requirement

Provide sufficient installation space for product safety.

⚠ CAUTION

Keep the space shown in the installation examples.

If the installation is not performed accordingly, it could cause a short circuit and result in a lack of operating performance.

● Single outdoor unit installation

- When the upper space is open:

Unit: mm

Obstacles at rear only

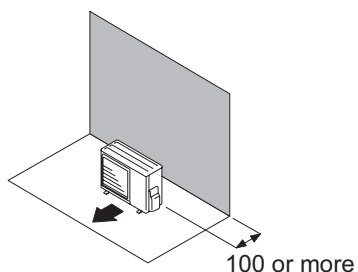

Obstacles at rear and sides

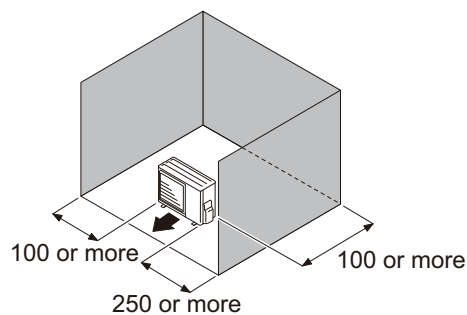

Obstacles at front

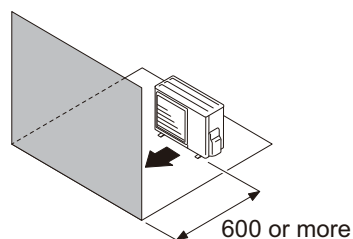

Obstacles at front and rear

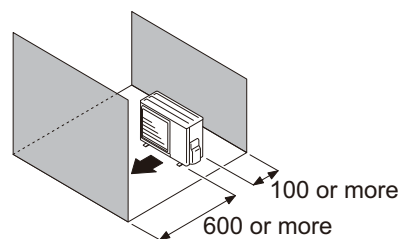

- When there is an obstruction in the upper space:

Unit: mm

Obstacles at rear and above

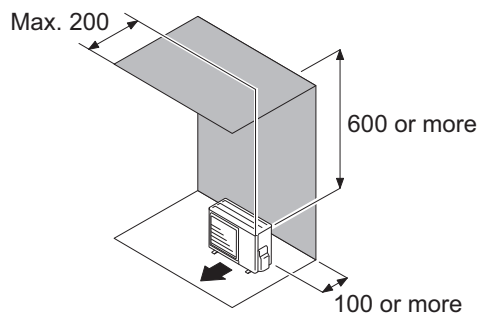

Obstacles at rear, sides, and above

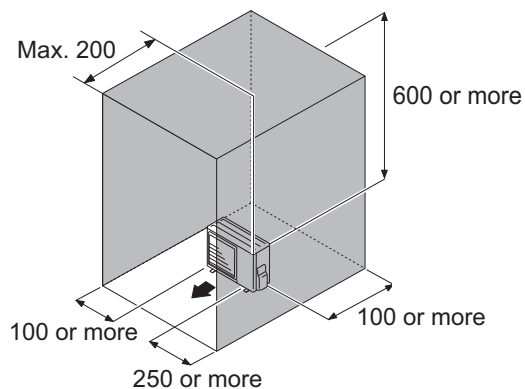

● Multiple outdoor unit installation

- Provide at least 250 mm of space between the outdoor units if multiple units are installed.
- When routing the piping from the side of an outdoor unit, provide space for piping.
- No more than 3 units must be installed side by side.
When 3 units or more are arranged in a line, provide the space as shown in the following example **“When an obstruction in the upper space:”**.
- **When the upper space is open:**

Unit: mm

Obstacles at rear only

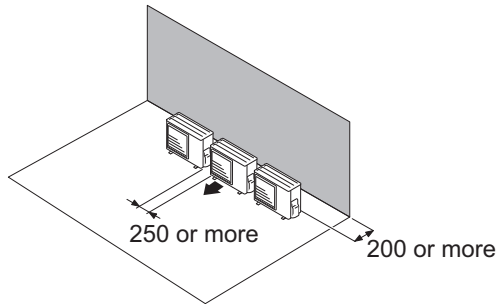

Obstacles at front only

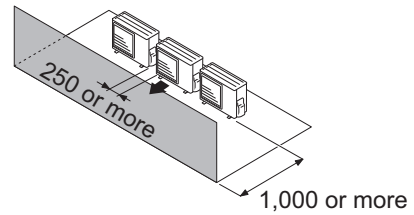

Obstacles at front and rear

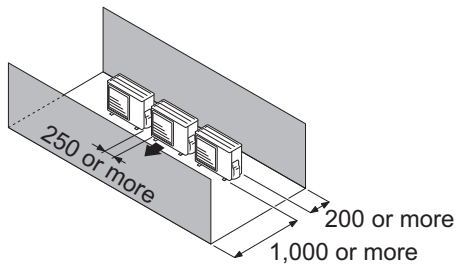

- **When an obstruction in the upper space:**

Unit: mm

Obstacles at rear and above.

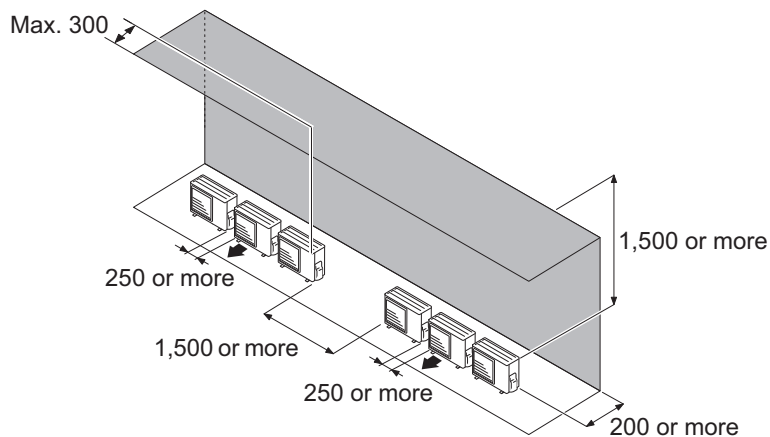

● Outdoor units installation in multi-row

Unit: mm

Single parallel unit arrangement

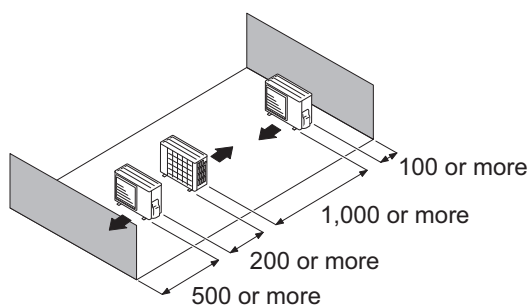

Multiple parallel unit arrangement

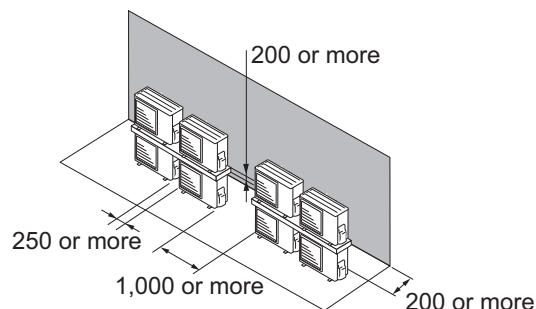
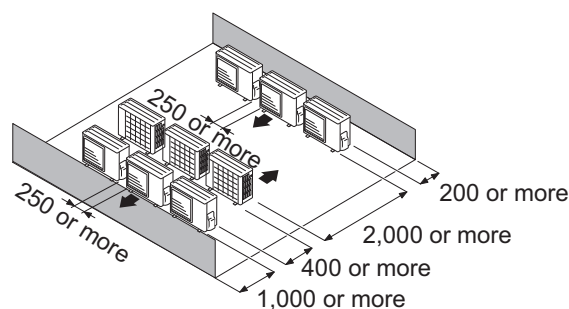

NOTES:

- If the space is larger than stated above, the condition will be the same as when there is no obstacle.
- When installing the outdoor unit, be sure to open the front and left side to obtain better operation efficiency.

⚠ CAUTION

- Do not install the outdoor unit in two-stage where the drain water could freeze. Otherwise the drainage from the upper unit may form ice and cause a malfunction of the lower unit.
- When the outdoor temperature is 0 °C or less, do not use the accessory drain pipe and drain cap. If the drain pipe and drain cap are used, the drain water in the pipe may freeze in extremely cold climate. (For reverse cycle model only.)
- In area with heavy snowfall, if the inlet and outlet of the outdoor unit is blocked with snow, it might become difficult to get warm, and it is likely to cause product malfunction. Construct a canopy and a pedestal, or place the unit on a high stand that is locally installed.

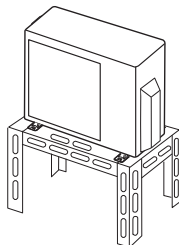

4. Refrigerant circuit

4-1. Model: AOYG18KBTB

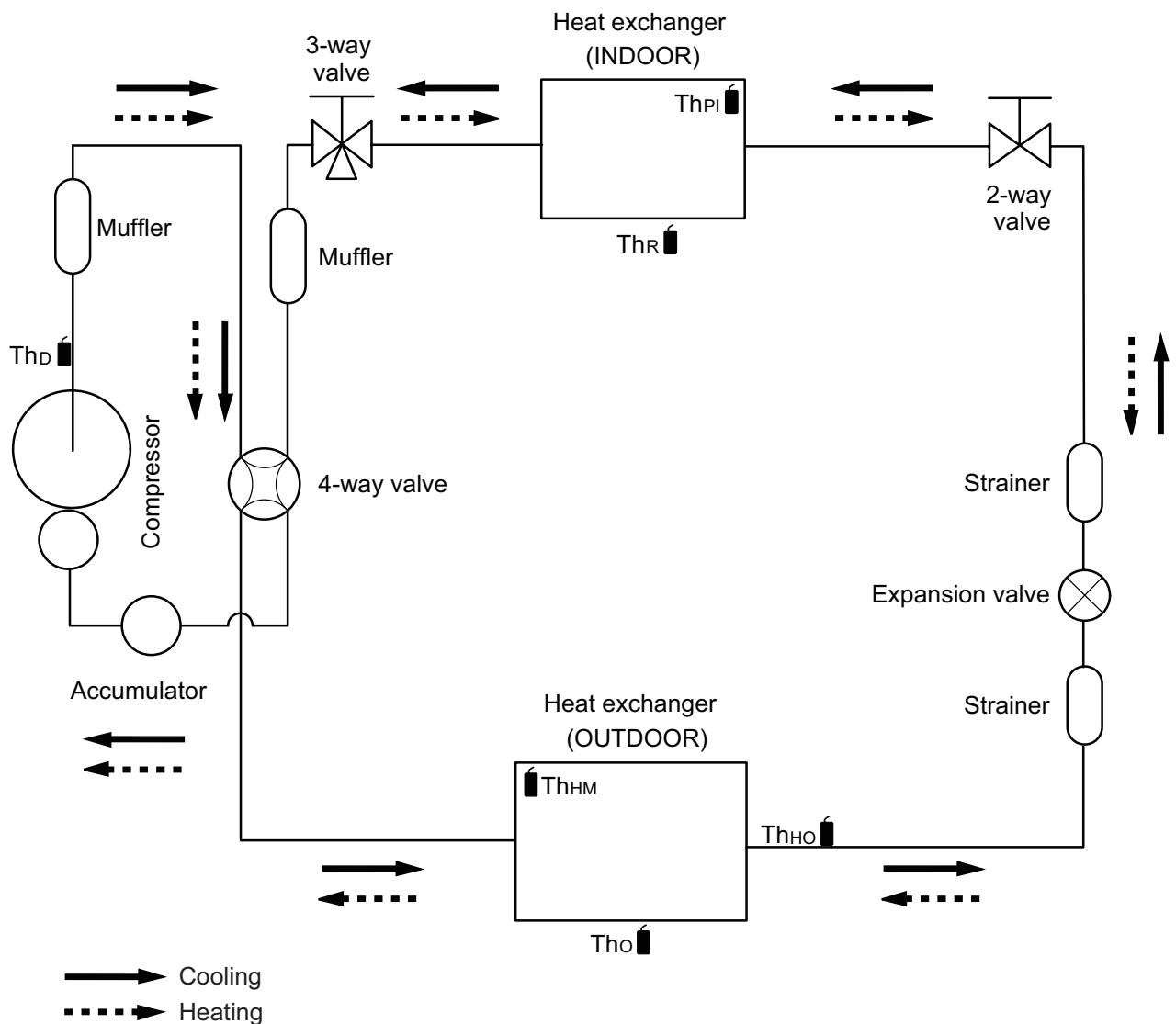

Th_D : Thermistor (Discharge temperature)

Th_O : Thermistor (Outdoor temperature)

Th_{HO} : Thermistor (Heat exchanger out temperature)

Th_{HM} : Thermistor (Heat exchanger middle temperature)

Th_R : Thermistor (Room temperature)

Th_{PI} : Thermistor (Pipe temperature)

4-2. Model: AOYG22KBTB

OUTDOOR UNIT
AOYG18, 22KBTB

OUTDOOR UNIT
AOYG18, 22KBTB

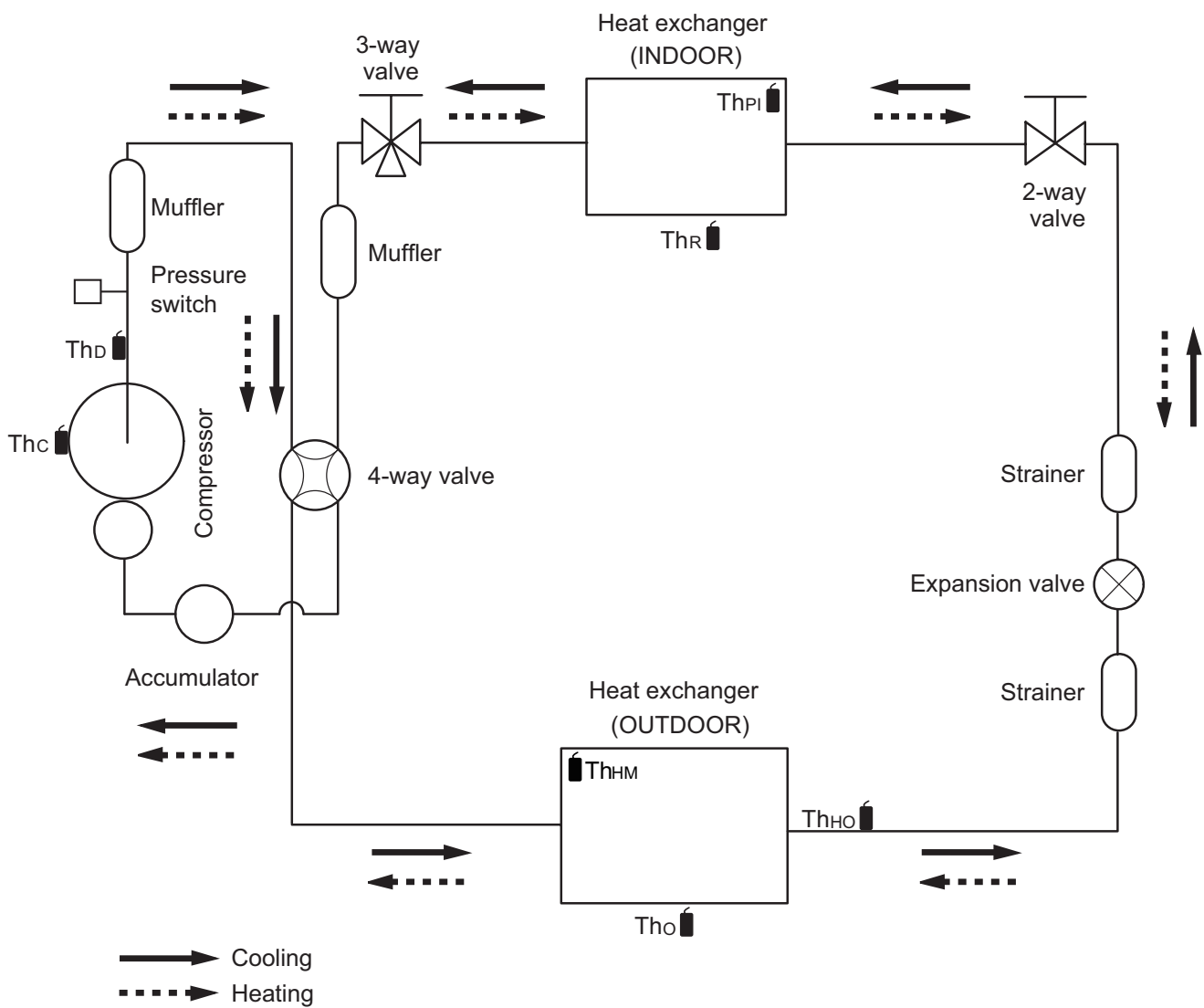

- Thc : Thermistor (Compressor temperature)
- Thd : Thermistor (Discharge temperature)
- Tho : Thermistor (Outdoor temperature)
- Thho : Thermistor (Heat exchanger out temperature)
- Thhm : Thermistor (Heat exchanger middle temperature)
- Thr : Thermistor (Room temperature)
- Thpi : Thermistor (Pipe temperature)

5. Wiring diagrams

5-1. Model: AOYG18KBTB

OUTDOOR UNIT
AOYG18, 22KBTB

OUTDOOR UNIT
AOYG18, 22KBTB

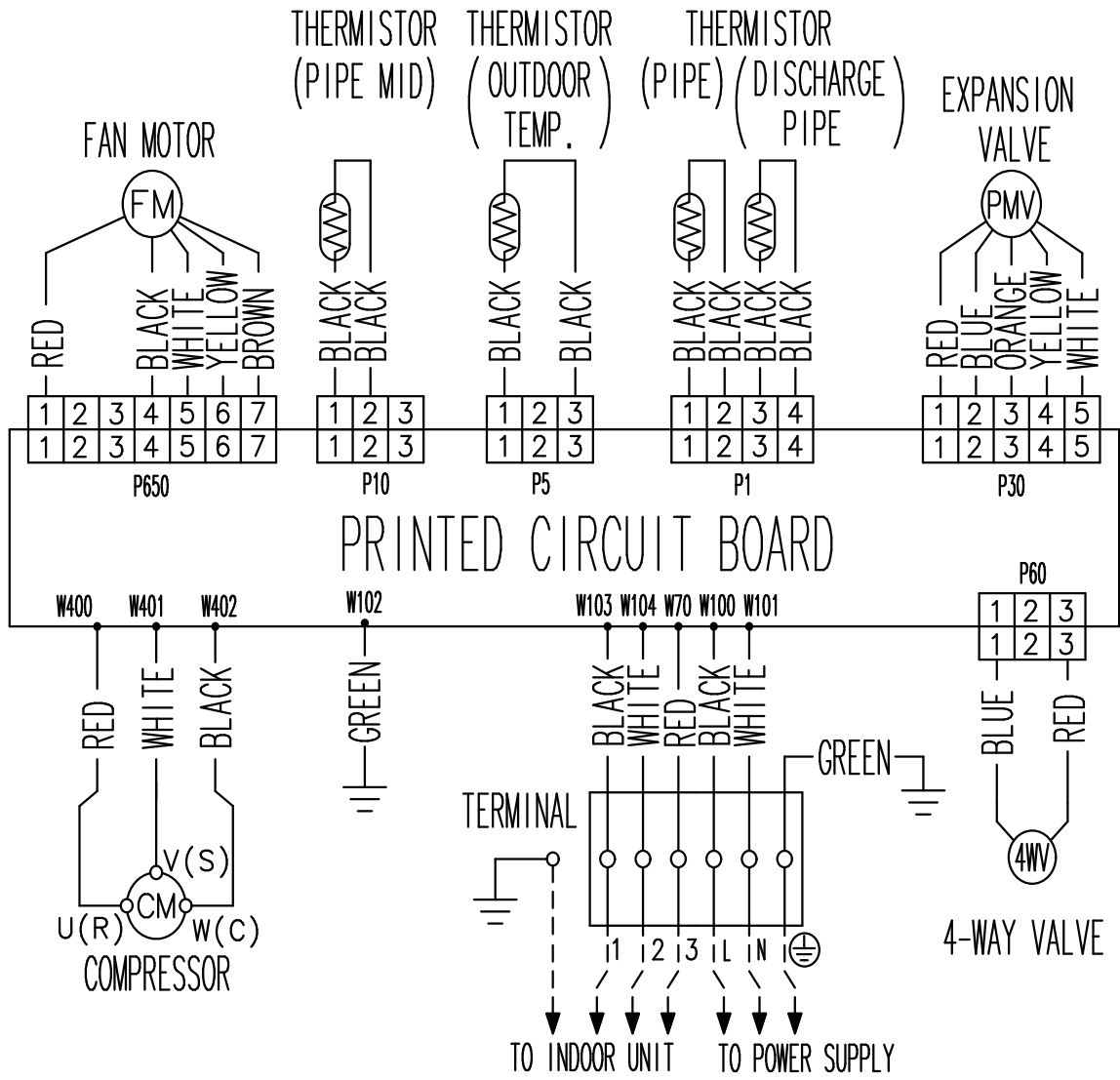

5-2. Model: AOYG22KBTB

OUTDOOR UNIT
AOYG18, 22KBTB

OUTDOOR UNIT
AOYG18, 22KBTB

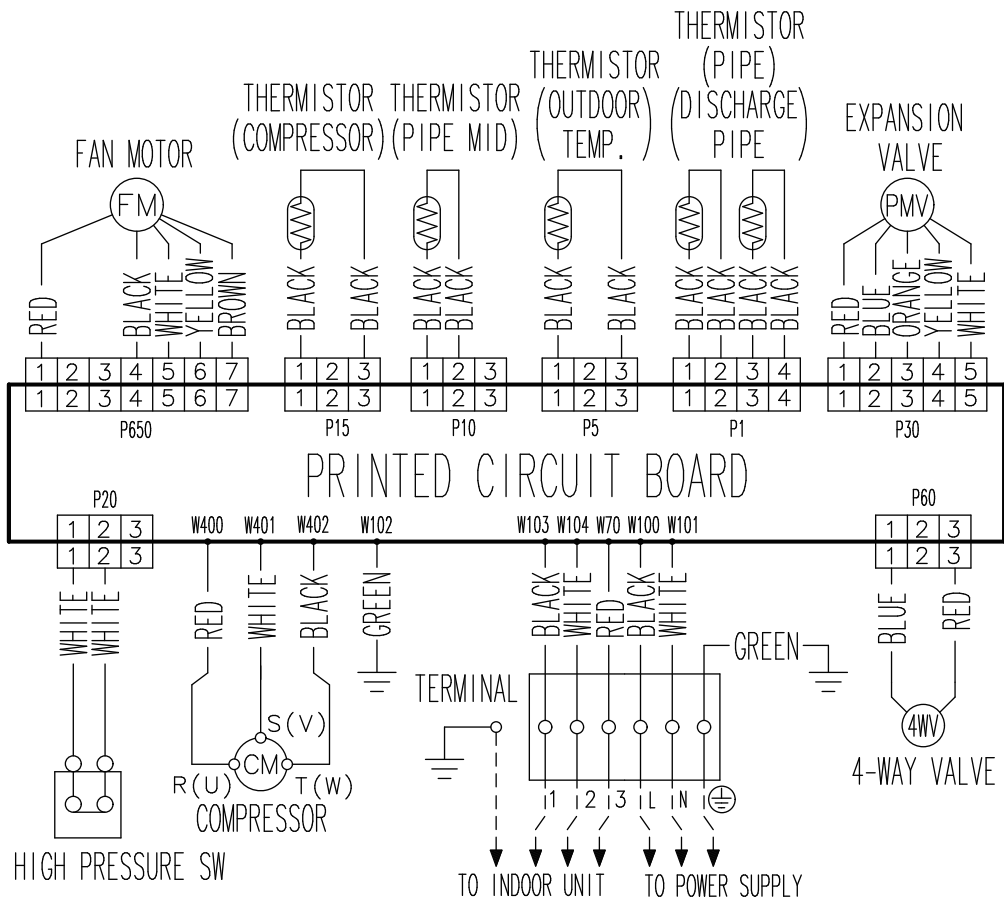

6. Capacity compensation rate for pipe length and height difference

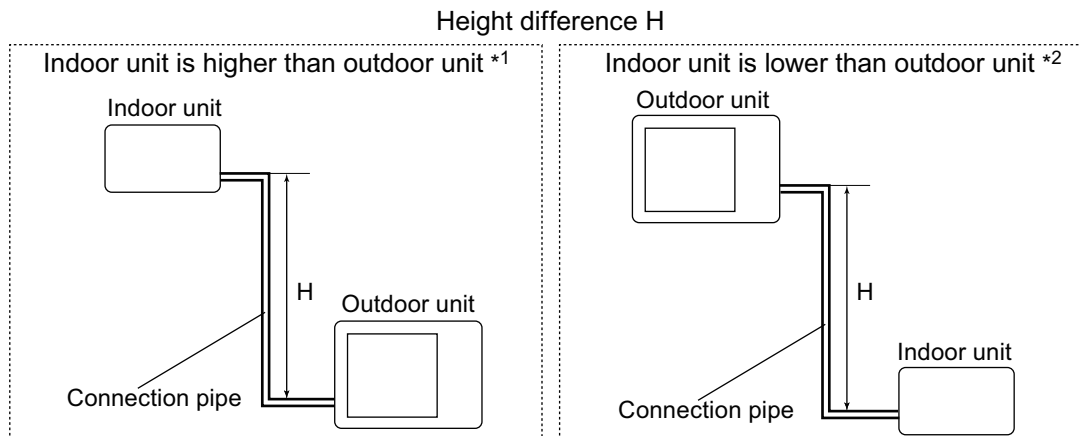

6-1. Model: AOYG18KBTB

NOTE: Values mentioned in the table are calculated based on the maximum capacity.

COOLING			Pipe length (m)						
			5	7.5	10	15	20	25	30
Height difference H (m)	Indoor unit is higher than outdoor unit *1	20	—	—	—	—	0.932	0.930	0.924
		15	—	—	—	0.953	0.950	0.947	0.941
		10	—	—	0.983	0.968	0.966	0.962	0.956
		7.5	—	0.988	0.987	0.972	0.970	0.966	0.960
		5	0.992	0.992	0.991	0.976	0.974	0.970	0.964
	Indoor unit is lower than outdoor unit *2	0	1.000	1.000	0.999	0.984	0.982	0.978	0.972
		-5	1.000	1.000	0.999	0.984	0.982	0.978	0.972
		-7.5	—	1.000	0.999	0.984	0.982	0.978	0.972
		-10	—	—	0.999	0.984	0.982	0.978	0.972
		-15	—	—	—	0.984	0.982	0.978	0.972
		-20	—	—	—	—	0.982	0.978	0.972

HEATING			Pipe length (m)						
			5	7.5	10	15	20	25	30
Height difference H (m)	Indoor unit is higher than outdoor unit *1	20	—	—	—	—	0.894	0.867	0.839
		15	—	—	—	0.920	0.894	0.867	0.839
		10	—	—	0.982	0.920	0.894	0.867	0.839
		7.5	—	1.000	0.982	0.920	0.894	0.867	0.839
		5	1.000	1.000	0.982	0.920	0.894	0.867	0.839
	Indoor unit is lower than outdoor unit *2	0	1.000	1.000	0.982	0.920	0.894	0.867	0.839
		-5	0.995	0.995	0.977	0.916	0.889	0.862	0.836
		-7.5	—	0.993	0.975	0.913	0.887	0.860	0.832
		-10	—	—	0.972	0.911	0.885	0.858	0.830
		-15	—	—	—	0.902	0.876	0.849	0.821
		-20	—	—	—	—	0.863	0.834	0.809

6-2. Model: AOYG22KBTB

NOTE: Values mentioned in the table are calculated based on the maximum capacity.

COOLING			Pipe length (m)						
			5	7.5	10	15	20	25	30
Height difference H (m)	Indoor unit is higher than outdoor unit *1	25	—	—	—	—	0.909	0.909	0.903
		15	—	—	—	0.953	0.950	0.947	0.941
		10	—	—	0.983	0.968	0.966	0.962	0.956
		7.5	—	0.988	0.987	0.972	0.970	0.966	0.960
		5	0.992	0.992	0.991	0.976	0.974	0.970	0.964
	Indoor unit is lower than outdoor unit *2	0	1.000	1.000	0.999	0.984	0.982	0.978	0.972
		-5	1.000	1.000	0.999	0.984	0.982	0.978	0.972
		-7.5	—	1.000	0.999	0.984	0.982	0.978	0.972
		-10	—	—	0.999	0.984	0.982	0.978	0.972
		-15	—	—	—	0.984	0.982	0.978	0.972
-25	—	—	—	—	0.982	0.978	0.972		

HEATING			Pipe length (m)						
			5	7.5	10	15	20	25	30
Height difference H (m)	Indoor unit is higher than outdoor unit *1	25	—	—	—	—	0.894	0.867	0.839
		15	—	—	—	0.920	0.894	0.867	0.839
		10	—	—	0.982	0.920	0.894	0.867	0.839
		7.5	—	1.000	0.982	0.920	0.894	0.867	0.839
		5	1.000	1.000	0.982	0.920	0.894	0.867	0.839
	Indoor unit is lower than outdoor unit *2	0	1.000	1.000	0.982	0.920	0.894	0.867	0.839
		-5	0.995	0.995	0.977	0.916	0.889	0.862	0.836
		-7.5	—	0.993	0.975	0.913	0.887	0.860	0.832
		-10	—	—	0.972	0.911	0.885	0.858	0.830
		-15	—	—	—	0.902	0.876	0.849	0.821
-25	—	—	—	—	0.851	0.821	0.795		

7. Additional charge calculation

7-1. Model: AOYG18KBTB

Refrigerant type		R32
Refrigerant amount	g	1,020

■ Refrigerant charge

Total pipe length	m	20 or less	25	30 (Max.)	20 g/m
Additional charge	g	0	100	200	

7-2. Model: AOYG22KBTB

Refrigerant type		R32
Refrigerant amount	g	1,250

■ Refrigerant charge

Total pipe length	m	20 or less	25	30 (Max.)	20 g/m
Additional charge	g	0	100	200	

8. Airflow

8-1. Model: AOYG18KBTB

● Cooling

m ³ /h	2,160
l/s	600
CFM	1,271

● Heating

m ³ /h	1,830
l/s	508
CFM	1,077

8-2. Model: AOYG22KBTB

● Cooling

m ³ /h	2,240
l/s	622
CFM	1,318

● Heating

m ³ /h	1,960
l/s	544
CFM	1,154

9. Operation noise (sound pressure)

9-1. Noise level curve

Model: AOYG18KBTB

Cooling

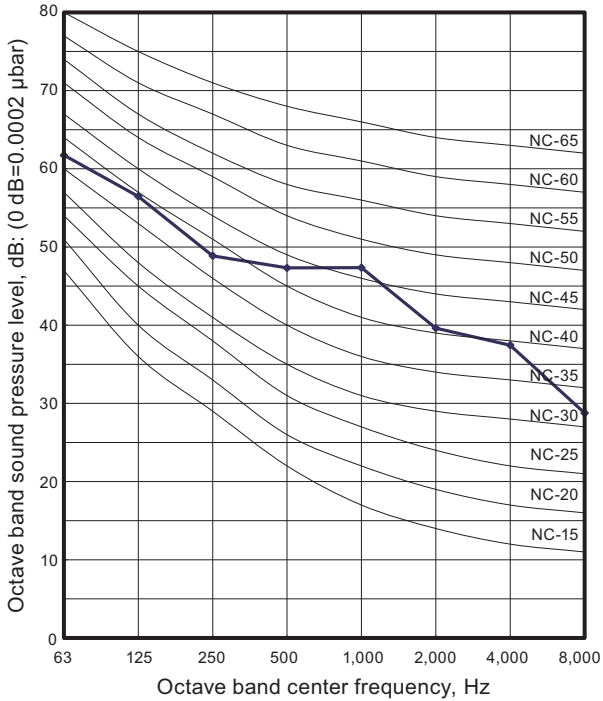

Heating

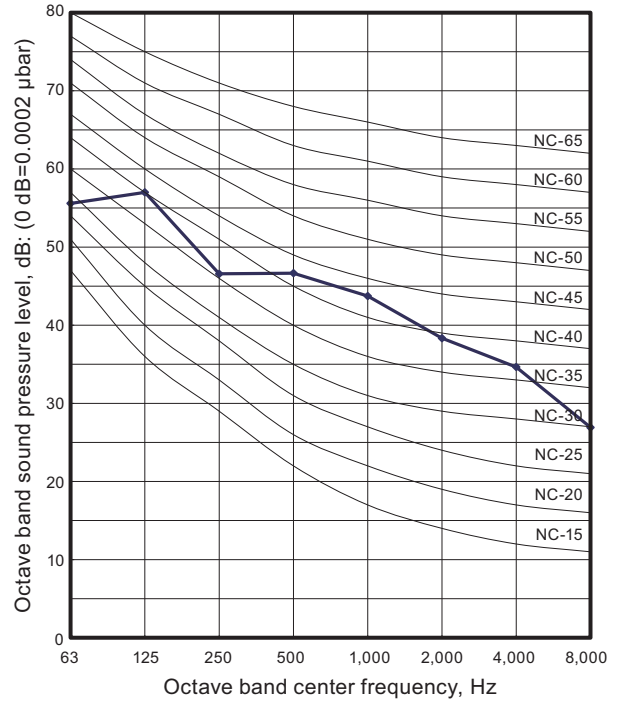

Model: AOYG22KBTB

Cooling

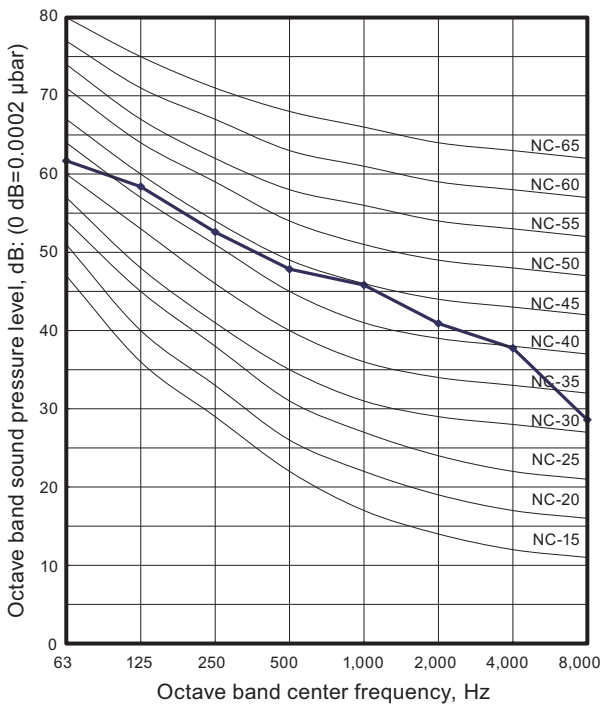

Heating

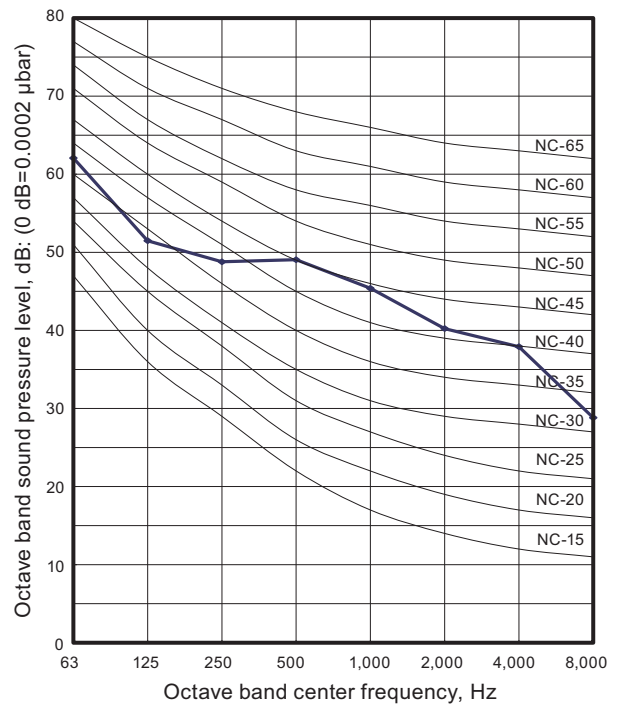

OUTDOOR UNIT
AOYG18, 22KBTB

OUTDOOR UNIT
AOYG18, 22KBTB

9-2. Sound level check point

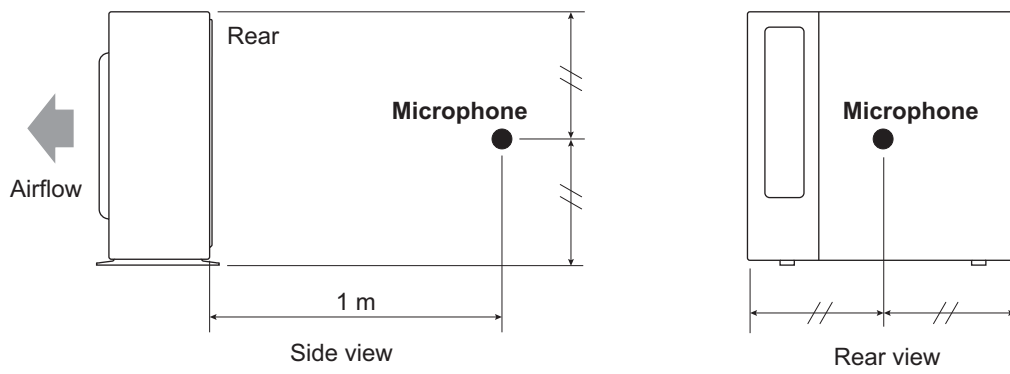

NOTE: Detailed shape of the actual outdoor unit might be slightly different from the one illustrated above.

10. Electrical characteristics

Model name			AOYG18KBTB	AOYG22KBTB
Power supply	Voltage	V	230 ~	
	Frequency	Hz	50	
Max operating current *1		A	12.1	12.6
Starting current		A	7.1	8.2
Wiring spec. *2	Circuit breaker current		A	16
	Power cable		mm ²	1.5
	Connection cable *3	Cross-sectional area	mm ²	1.5
		Limited wiring length	m	31

*1: Maximum operating current is the total current of the indoor unit and the outdoor unit.



*2: Selected sample based on Japan Electrotechnical Standards and Codes Committee E0005. As the regulations of wire size and circuit breaker differ in each country or region, select appropriate devices complied to the regional standard.

11. Safety devices

Type of protection	Protection form		Model		
			AOYG18KBTB	AOYG22KBTB	
Circuit protection	Current fuse (Main PCB)		250 V, 25 A		
			250 V, 5 A		
			250 V, 3.15 A		
Fan motor protection	Terminal protection program	Activate	125±10 °C Fan motor stop		
		Reset	120±10 °C Fan motor restart		
Compressor protection	Terminal protection program (Discharge temp.)	Activate	110 °C Compressor stop		
		Reset	After 7 minutes Compressor restart		
	Terminal protection program (Compressor temp.)	Activate	—	108 °C Compressor stop	
		Reset	—	After 3 minutes, and 80 °C or less Compressor restart	
	Thermal protection program (Outdoor temp.) (Only in COOL or DRY mode)	Activate	-20 °C Compressor stop		
		Reset	-15 °C Compressor restart		
High pressure protection	Pressure switch	Activate	—	4.2 ⁺⁰ _{-0.15} MPa Compressor stop	
		Reset	—	3.2 ±0.15 MPa Compressor restart	

12. Accessories

12-1. Models: AOYG18KBTB and AOYG22KBTB

Part name	Exterior	Q'ty	Part name	Exterior	Q'ty
Installation manual		1	Drain pipe		1