

INSTRUCTION MANUAL

•INSTALLATION •SETTING •OPERATING

BACnet[®] Gateway for VRF System

UTY-ABGX

Ver. 2.3



PART NO. 9708568010-06

FUJITSU GENERAL LIMITED

LICENSE AGREEMENT
For
“BACnet® Gateway for VRF System”

IMPORTANT-READ CAREFULLY

This “BACnet® GATEWAY for VRF SYSTEM” License Agreement (“LICENSE AGREEMENT”) is a legal agreement between you and Fujitsu General Limited (“FGL”) for the use of VRF BACnet® GATEWAY products consisting of computer software and online, electronic and/or printed documentation (collectively “SOFTWARE PRODUCT” or “SOFTWARE”). By installing, copying, or otherwise using the SOFTWARE PRODUCT, you accept to be bound by all of the terms and conditions of this LICENSE AGREEMENT. If you do not agree to any of the terms and conditions of this LICENSE AGREEMENT, you shall not use the SOFTWARE PRODUCT and shall promptly return the SOFTWARE PRODUCT to the place where you have obtained it.

1. COPYRIGHT AND OWNERSHIP.

The SOFTWARE PRODUCT is protected by copyright laws and international copyright treaties as well as other intellectual property laws and treaties. The SOFTWARE PRODUCT is licensed to you, not sold. FGL owns the title, copyright, and other intellectual property rights in the SOFTWARE PRODUCT.

2. GRANT OF LICENSE.

FGL hereby grants you the limited, non-exclusive and non-transferable rights to use the SOFTWARE PRODUCT only for the purpose of controlling the VRF air-conditioning system products (VRF) provided you comply with all terms and conditions of this LICENSE AGREEMENT. You may copy the SOFTWARE PRODUCT solely for backup or archival purposes.

3. DESCRIPTION OF OTHER RIGHTS AND LIMITATIONS.

(1) LIMITATIONS ON REVERSE ENGINEERING, DECOMPILATION, AND DISASSEMBLY.

You shall not modify, alter, reverse engineer, decompile, or disassemble the SOFTWARE PRODUCT. You shall not alter or remove any copyright, trademark or other proprietary notice of FGL from the SOFTWARE PRODUCT.

(2) NO RENTAL, LEASE AND TRANSFER.

You shall not rent, lease or transfer the SOFTWARE PRODUCT to any person and/or entity (-ies).

(3) TERMINATION.

Without prejudice to any other rights, FGL may terminate this LICENSE AGREEMENT if you fail to comply with any terms and conditions of this LICENSE AGREEMENT. In such an event, you shall promptly return all originals and copies of the SOFTWARE PRODUCT to FGL.

4. INSTALLATION AND USE OF SOFTWARE PRODUCT.

You may install and use the enclosed SOFTWARE PRODUCT on a single computer under one of the operating environment identified in the documentation accompanying the SOFTWARE. You shall not network the SOFTWARE or otherwise use it on more than 1 computer at the same time. The infrastructure necessary to use the SOFTWARE PRODUCT (PC, accessories, etc.) shall be prepared separately by you.

5. NO WARRANTY.

FGL EXPRESSLY DISCLAIMS ANY WARRANTY FOR THE SOFTWARE PRODUCT. THE SOFTWARE PRODUCT IS PROVIDED “AS IS” WITHOUT WARRANTY OF ANY KIND, EITHER EXPRESSED OR IMPLIED, INCLUDING, WITHOUT LIMITATION, STATUTORY WARRANTIES, MERCHANTABILITY OR FITNESS FOR A PARTICULAR PURPOSE OR NON-INFRINGEMENT OF THIRD PARTY’S RIGHTS. THE ENTIRE RISKS ARISING OUT OF USE OR PERFORMANCE OF THE SOFTWARE PRODUCT REMAIN WITH YOU. HOWEVER, IF YOU NOTIFY FGL OF PHYSICAL DEFECT OF THE MEDIA CONTAINING SOFTWARE WITHIN (90) DAYS FOLLOWING YOUR RECEIPT OF THE SOFTWARE PRODUCT, FGL WILL REPLACE THE DEFECTIVE MEDIA WITH NEW MEDIA.

6. LIMITATION OF LIABILITY.

IN NO EVENT SHALL FGL BE LIABLE TO YOU OR TO ANY THIRD PARTY FOR ANY DIRECT OR INDIRECT DAMAGES WHATSOEVER (INCLUDING, WITHOUT LIMITATION, DAMAGES FOR LOSS OF BUSINESS PROFIT, BUSINESS INTERRUPTION OR LOSS OF BUSINESS INFORMATION, DAMAGES ARISING OUT OF DATA OR INFORMATION DERIVED FROM OR BASED ON THE ELECTRICITY CHARGE APPORTIONMENT FUNCTION IN THE SOFTWARE OR ANY OTHER PECUNIARY LOSS), ARISING OUT OF THE USE OR INABILITY TO USE THE SOFTWARE , EVEN IF FGL HAS BEEN ADVISED OF THE POSSIBILITY OF SUCH DAMAGES.

7. ENTIRE AGREEMENT.

This LICENSE AGREEMENT (including any addendum or amendment to this LICENSE AGREEMENT included with the SOFTWARE PRODUCT) is the entire agreement between you and FGL relating to the SOFTWARE PRODUCT and supersedes all prior contemporaneous oral or written communications, proposals and representations with respect to the SOFTWARE PRODUCT or any other subject covered by this LICENSE AGREEMENT.

8. INDEMNITY.

You agree to indemnify and hold FGL, and its subsidiaries, affiliates, officers, agents, co-branders or other partners, and employees, harmless from any damage, claim or demand, including without limitation reasonable attorneys' fees, made by any third party due to or arising out of use of the SOFTWARE PRODUCT.

9. GOVERNING LAW AND JURISDICTION.

This LICENSE AGREEMENT is governed by the laws of JAPAN. You and FGL hereby irrevocably consent to the exclusive jurisdiction and venue in the Tokyo District Court and other higher courts having jurisdiction in Japan for the settlement of disputes arising under or in connection with this LICENSE AGREEMENT.

Contents

1. Usage Precautions	6
1-1 Precautions When Using the BACnet® Gateway	6
2. How To Use This Manual	7
2-1 Manual Composition	7

Introduction

3. Overview	9
3-1 Features	9
4. Materials To Be Prepared Beforehand	10

Installation

5. Installation	12
5-1 Installation Flow	13
5-2 Hardware Installation (Transmission Adaptor)	14
5-2-1 Transmission Adaptor Installation	14
5-2-2 Wiring and Turning on the Units Power	16
5-3 Software Installation	17
5-4 Software Uninstallation	25
5-4-1 BACnet® Gateway Uninstallation	26
5-4-2 WIBU-KEY Driver Uninstallation	27
5-4-3 Microsoft® SQL Server® 2008 R2 Uninstallation	29

Settings

6. Basic Settings	32
6-1 When Starting for the First Time	32
6-2 "Selection of Unit Data Acquisition Method"	33
6-3 "Login Setting"	33
6-4 "Initial Setting"	34
6-5 "Adaptor Setting"	36
6-6 "Unit Registration"	37
6-7 "Description Property Setting"	40
6-8 "Change Password"	41
7. Electricity Charge Apportionment (ECA) Setting	42
7-1 Basic Setting Flow	42
7-2 Overview	43
7-3 "Model Name Setting"	46

Operation

8. Operation	48
8-1 Starting and Ending the BACnet® Gateway	48
8-2 Main Screen	50
8-3 “Data Import/Export”	52
8-3-1 “Unit List (EDE) Export”	52
8-3-2 “All Data Import”	53
8-3-3 “All Data Export”	54
8-4 “View”	55
8-5 “Control”	57
8-5-1 “Operation Setting”	57
8-5-2 “Device Communication Disable”	58
8-5-3 “Device Communication Disable_Initiation”	59
8-5-4 “Device Communication Enable”	60
8-5-5 “Out of Service”	61
8-6 “Error”	62
8-6-1 Displays “Error Information”	62
8-6-2 Displays “Error History”	63
8-7 “Help”	63
8-7-1 Displays “Manual”	63
8-7-2 Displays “Interface Specification Document”	64
8-7-3 Displays Application “Version Information”	64

Appendix

9. Product Specifications	66
9-1 Operating Conditions	66
9-2 Accessories	66
10. Error Code Table	67
11. FAQ	68
11-1 General	68
11-2 Trouble Shooting BACnet® Installation	71

- * Microsoft® and Windows® are registered trademarks of Microsoft Corporation in the United States.
- * Adobe® Reader® are registered trademarks of Adobe Systems Incorporated in the United States.
- * Intel®, Pentium® and Celeron® are registered trademarks of Intel Corporation or its subsidiaries in the United States.
- * ECHELON®, LONWORKS®, and the Echelon logo are trademarks of Echelon Corporation registered in the United States and other countries.
- * BACnet® is a registered trademark of the American Society of Heating, Refrigerating and Air-Conditioning Engineers, INC (ASHRAE).
- * XLON® is a registered trademark of DH electronics GmbH.
- * Portions of this software ©2001-2009 PolarSoft Inc.

1. Usage Precautions

1-1 Precautions When Using the BACnet® Gateway

1. Please read and agree to the LICENSE AGREEMENT FOR “BACnet® Gateway” at the beginning of this manual before using the BACnet® Gateway.
2. Please confirm that the PC for the BACnet® Gateway meets the operating condition of the “Product Specifications” described in the Appendix of this manual.
3. Please read and fully understand this manual before using the BACnet® Gateway.
4. Be careful not to shutdown or turn off the power supply of the PC or unplug its transmission adaptor. Do not terminate the BACnet® Gateway program unless necessary. Otherwise, normal operation of the BACnet® Gateway may not be performed.
5. To ensure continuous normal operation of this software, set the PC so that it would not go into an energy saving mode such as standby mode, sleep mode or execute hibernation. If the PC goes into a standby, sleep mode or execute hibernation, this software may not function properly. The method for releasing the energy saving or hibernation of the PC depends on the Windows versions. For windows® 7, right click the desktop to select "Personalize" and click "Screen Saver" icon to select "Change power settings". Check "Power saver" in the "Preferred plans" and select "Change plan settings" to set "Never".
6. The DVD for this software and the software protection key (WIBU-KEY) will not be reissued. Keep and handle them with great care after installing.
7. BACnet® Gateway programs perform schedules, operation recording and electricity apportionment data control based on date and time set in the personal computer. Adjust date and time periodically and by a small amount. Changing date and time may affect the functions listed above. When the date/time of the PC running BACnet® Gateway is adjusted to roll back in time, the data collected for the electricity charge apportionment for that period will be deleted and be newly collected. When the date/time is adjusted to roll forward in time, there will be no data for that period. Such cases will result in incorrect calculation results for the electricity charge apportionment so the user should be careful when adjusting date/time for the PC.
8. When program execution environment of Windows® is corrupted or abnormal, or if other software is installed or running on the same PC, operation of BACnet® Gateway may be interfered and may not install or run properly. It is usually extremely difficult to detect such conditions, if it occurs. It is recommended that BACnet® Gateway be installed on a new PC, dedicated for the use of BACnet® Gateway.
9. BACnet® Gateway product is provided with software, drivers, components listed below. If the same kind of software, drivers, components with different version is installed on the same PC, BACnet® Gateway may not install or run properly.
 - (1) Microsoft® SQL Server® Express
 - (2) OpenLDV (U10 USB Network Interface driver)
 - (3) WIBU-KEY driver
10. This product may be updated without prior notice. If by chance you encounter any trouble with this product, check with your dealer for updates.

2. How To Use This Manual

2-1 Manual Composition

This manual is composed of 5 sections.

- Introduction
- Installation
- Settings
- Operation
- Appendix

Before installing the software, read the Introduction first and check the Overview of the BACnet® Gateway and the notes and cautions.

When installing the BACnet® Gateway to the PC, read the Installation and Settings sections. Complete installation to the PC in accordance with the procedure described.

When performing operations related to various functions of the BACnet® Gateway after installation, refer to the relevant parts of the operation section.

The Appendix is made up of product specifications, error code table, and FAQ. Read them as required.

Interface Specification document is also available and should be referred to along with this manual.

Introduction

3. Overview
4. Materials To Be Prepared Beforehand

3. Overview

3-1 Features

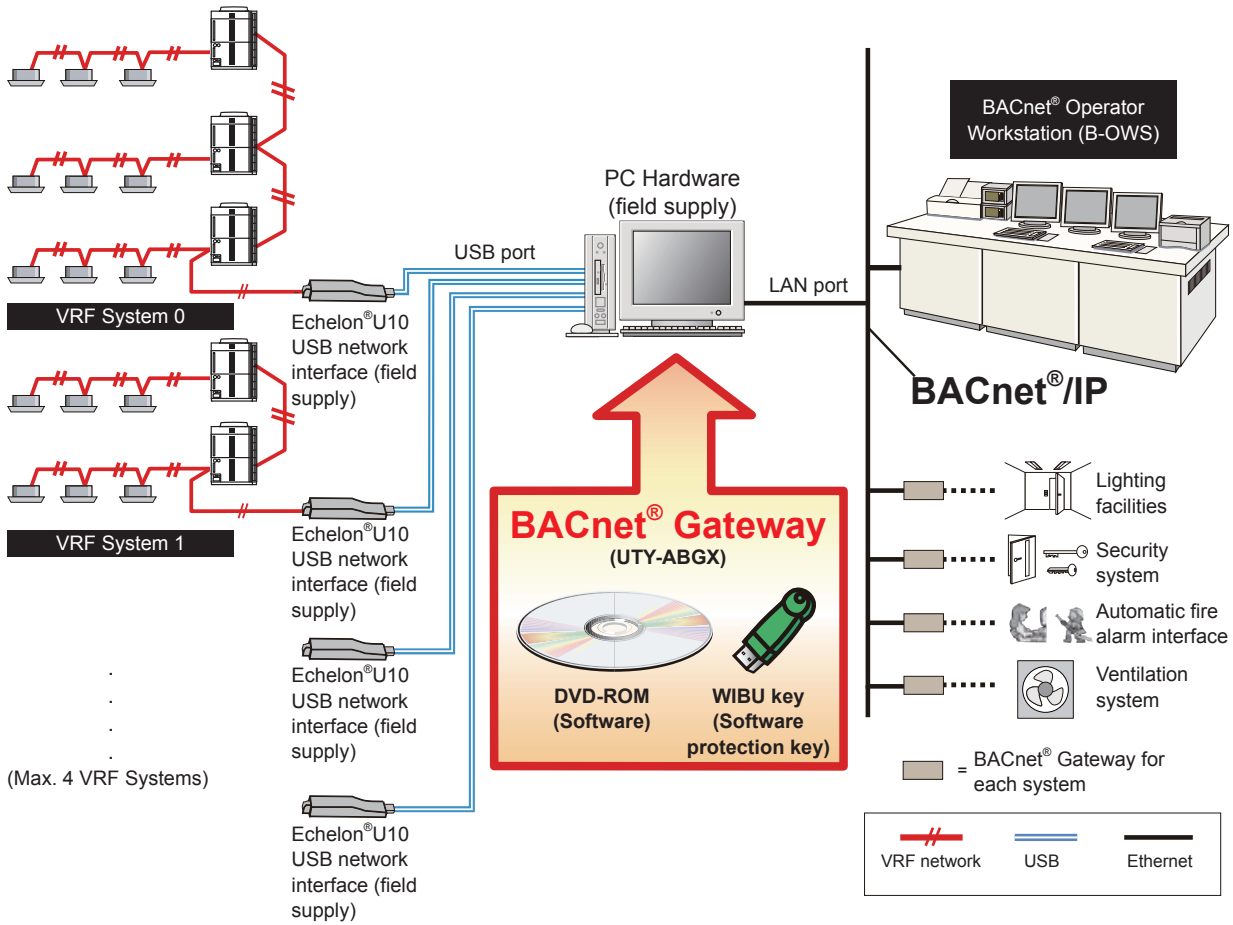

- BACnet® Specification of UTY-ABGX
- ANSI / ASHRAE Standards 135-2004
 - BACnet® Application Specific Controller (B-ASC)
 - BACnet® / IP over Ethernet

The maximum number of connecting systems

VRF System	4 systems
------------	-----------

For the numbers of the Units that can connect with 1 VRF System, Indoor and Outdoor Units are up to 400 units and up to 100 units respectively.

* VRF System Address:

The numbers from 0 to 3, which are assigned to each VRF System in the BACnet® Gateway.

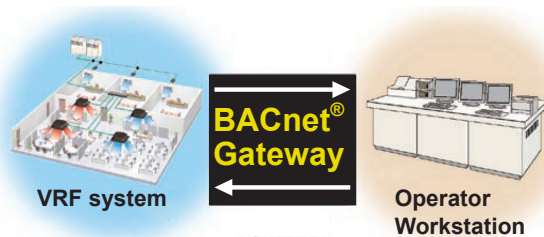

4. Materials To Be Prepared Beforehand

Materials necessary at installation

- WIBU-KEY (packed together with product)
- U10 USB Network Interface (adaptor with connection to VRF network work finished)
- Administrator ID and password for Windows login (arbitrarily decided by the user. 2 byte characters cannot be used.)
- BACnet® Gateway setup DVD (For details, see the next page.)
- IP address

When number of USB ports for WIBU-KEY and U10 USB Network Interface are insufficient;

- USB hub

Setup DVD configuration (Reference)

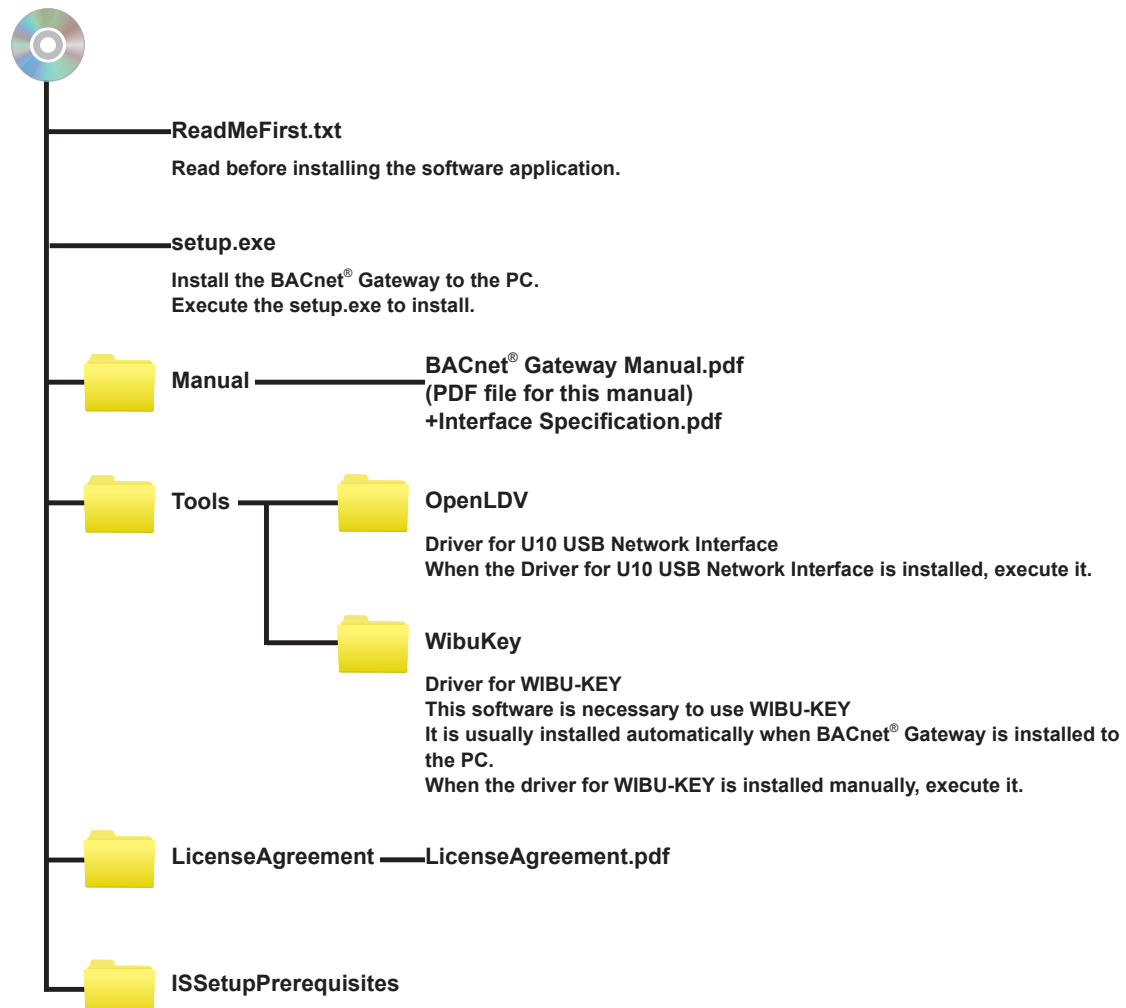

Installation

5. Installation

5. Installation

This section describes the procedure when installing the BACnet® Gateway software to the PC which connects directly to the VRF network. The PC communicates directly with the indoor and outdoor units.

The PC and VRF network are connected by a Transmission Adaptor (U10 USB Network Interface).

This section also describes how to uninstall the software when BACnet® Gateway software becomes unnecessary and also, how to reinstall the installed software due to software upgrading or other reasons.

5-1 Installation Flow

Installation/Setting Flow

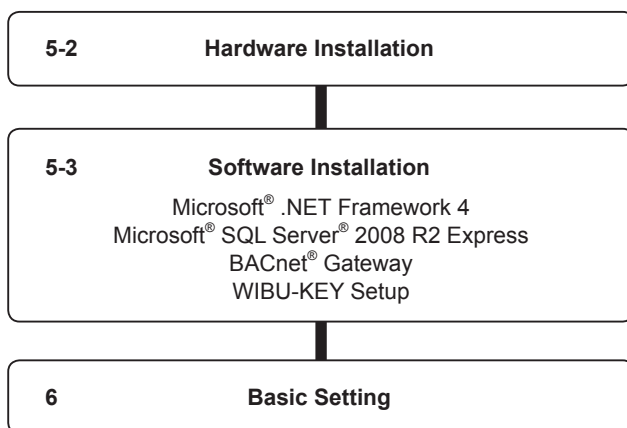

WARNING!

- ① BACnet® Gateway is tested to install and operate under new Windows environment. When program executional environment of Windows is corrupted or abnormal, or other softwares that interfere with the operation of BACnet® Gateway is installed or running, BACnet® Gateway may not install or run properly. It is usually extremely difficult to detect such conditions, if it occurs.
- ② BACnet® Gateway product is provided with softwares, drivers, components listed below. If the same kind of softwares, drivers, components with different version is installed on the same PC, BACnet® Gateway may not install or run properly.
 - (1) Microsoft® SQL Server® Express
 - (2) Open LDV (U10 USB Network Interface driver)
 - (3) WIBU-KEY-driver
- ③ Do not insert U10 USB network interface adaptor to the USB slot of the PC BEFORE its driver is installed.
- ④ Do not turn on the power of indoor/outdoor units until all installation work is completed.
- ⑤ Do not insert WIBU-KEY to the USB port of the PC until instructed.

5-2 Hardware Installation (Transmission Adaptor)

5-2-1 Transmission Adaptor Installation

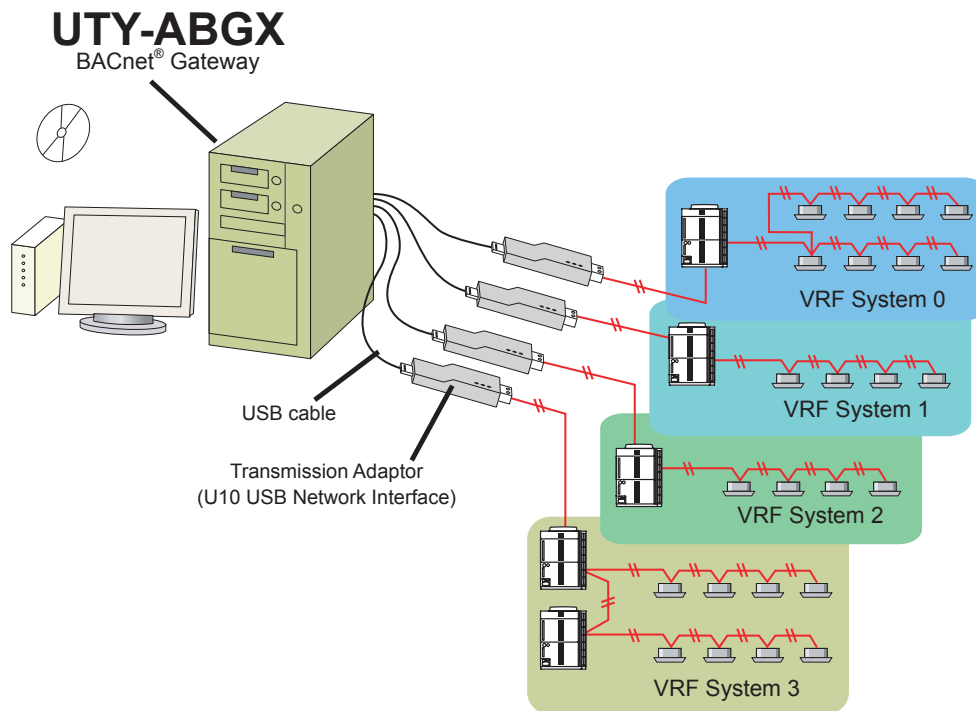

The BACnet® Gateway can connect up to 4 VRF Systems. Since 1 Transmission Adaptor connects to 1 system, up to 4 Transmission Adaptors are connected.

Following chart shows the detail of the U10 USB Network Interface Adaptor. These adaptors are not included in the BACnet® Gateway product and must be procured in advance.

Name & Shapes	Q'ty	Remark
Transmission Adaptor (U10 USB Network Interface -TP/FT-10 Channel) (Field Supply)	Procure the necessary number in accordance with the number of connection systems.	Model : 75010R (Echelon® Corporation)

It is necessary that set Transmission adaptor respectively because of the S/V series and V-II/J-II/VR-II series can not be connected to the same communication line.

Installing U10 USB Network Interface Adaptor

To use this product, turn on the power of the PC and install necessary drivers/software for this product (BEFORE connecting it to any USB port), following the ***QUICK START*** enclosed with this product.

- ① When using multiple U10 USB Network Interface adaptors, confirm in advance, which U10 USB Network Interface adaptor connects to which VRF Network (Attach labels to the U10 USB Network Interface adaptors If possible). These information will become necessary during the setup procedure of BACnet® Gateway (You will be required to specify which U10 USB Network Interface adaptor corresponds to which VRF network).

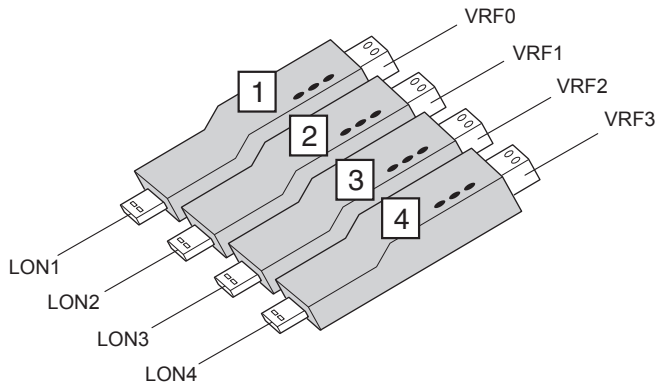

Keeping a record of a table such as shown below is recommended.

LON No.	Adaptor No.	VRF System No.
LON1	Adaptor 1	VRF 0
LON2	Adaptor 2	VRF 1
LON3	Adaptor 3	VRF 2
LON4	Adaptor 4	VRF 3

Note. "LONx" is used to identify U10 USB Network Interface adaptor. LON numbers are given in the order they are inserted to a PC for the first time and basically, never changes, even if you change USB slot afterwards.

- ② Connect the U10 USB Network Interface adaptor to the personal computer USB port. When there are multiple U10 USB Network Interface adaptors, connect each U10 USB Network Interface adaptor in the order of its LON number.

5-2-2 Wiring and Turning on the Units Power

Once the wiring has been installed, the power can be turned on. Follow the procedure below for turning on the power.

- ① Connect VRF network cables to the corresponding U10 USB Network Interface adaptors.
- ② Turn on the power for all connected indoor units.
- ③ Turn on the power for all connected outdoor units.

Note

Make sure that USB equipment (USB hub, etc.) that this product is connected to, is not overloaded (power supplied thru the interface does not exceeds the maximum limit).

- ④ Turn on the power for BACnet® Gateway PC, if it is not yet turned on.

5-3 Software Installation

The following software is installed here.

- Microsoft® .NET Framework 4
- Microsoft® SQL Server® 2008 R2 Express
- BACnet® Gateway
- WIBU-KEY driver

Before starting the installation of this product, check each of the followings.

- Install Adobe® Reader® (Ver. 9.0 or later) prior to the installation. (Adobe® Reader® does not come with this product).
- Have the installation DVD of the Windows version (Windows® XP, Windows Vista® or Windows® 7) used for the PC ready.

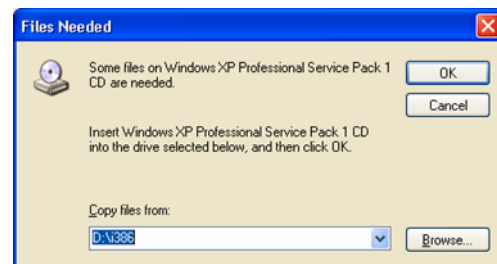
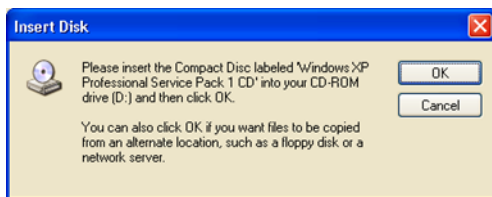

- Remove all program as described in “5-4 Software Uninstallation” , if you have the same or previous version of BACnet® Gateway.
- Do NOT insert WIBU-KEY (Software protection key) enclosed with this product to the PC until product installation is completed.
- You are required to login to the computer as Administrator (or equivalent) to the PC to install this product. (Enter the ID with single-byte characters.)
- Stop all running programs before you start the installation.
- If Anti-Virus software product is installed, temporarily disable the software during the installation of this product.

① Execute setup.exe in the root folder on the BACnet® Gateway setup DVD.

- Microsoft® .NET Framework 4
.NET Framework 4 is installed automatically if it is not already installed.
- Microsoft® SQL Server® 2008 R2 Express
Microsoft® SQL Server® 2008 R2 Express is installed automatically if it is not already installed.

- ② Select the language.
Select the desired language.
- ③ Click the “OK” button.

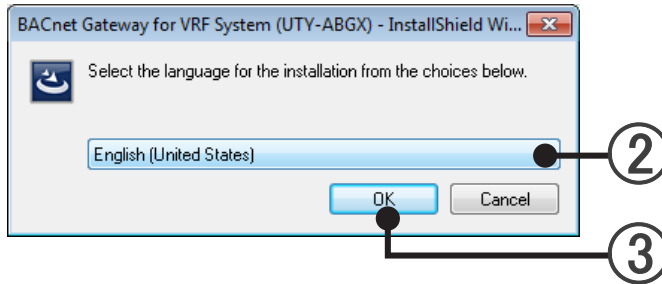

- ④ Click the “Install” button.

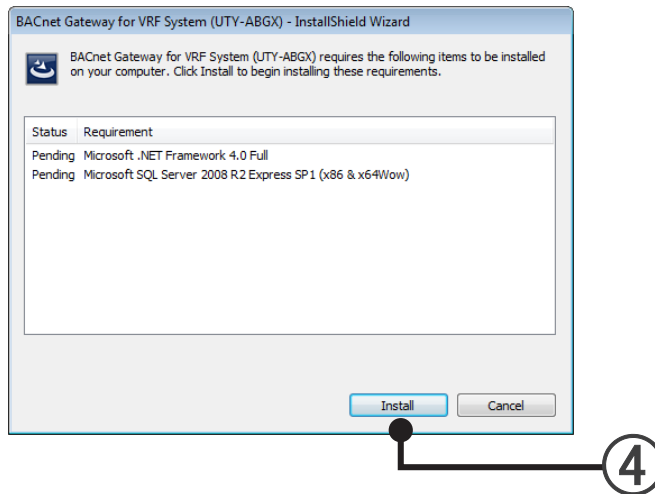

- ⑤ When “Install” is selected, installation begins.
a When “ReadMeFirst.txt” is selected, ReadMe is displayed.

Note

Be sure to read it for important information.

- b When “Manual” is selected, the manual is displayed.

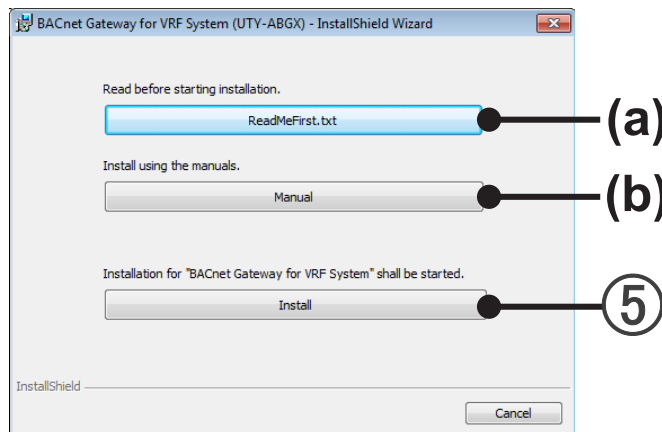

- BACnet® Gateway

⑥ Install BACnet® Gateway. Click the “Next” button.

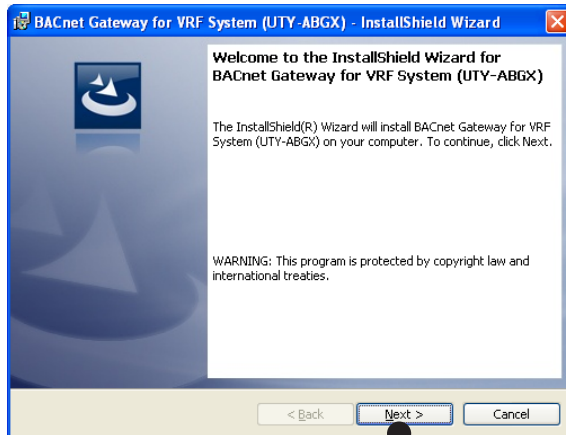

⑦ If the BACnet® Gateway end user “License Agreement” is displayed, confirm the contents. If you can agree to the terms of the “License Agreement”, check “I accept the terms in the license agreement” and click the “Next” button.

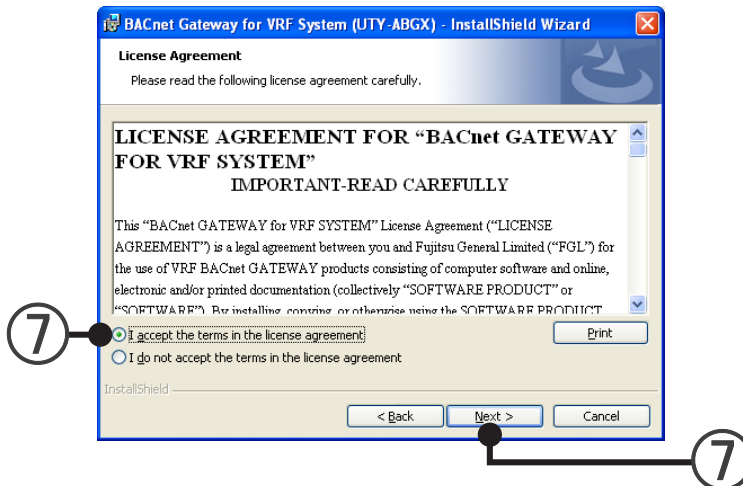

⑧ Specify the installation “Destination Folder” and click the “Next” button. (To change the installation “Destination Folder”, click the “Change” button and select the folder to be installed.)

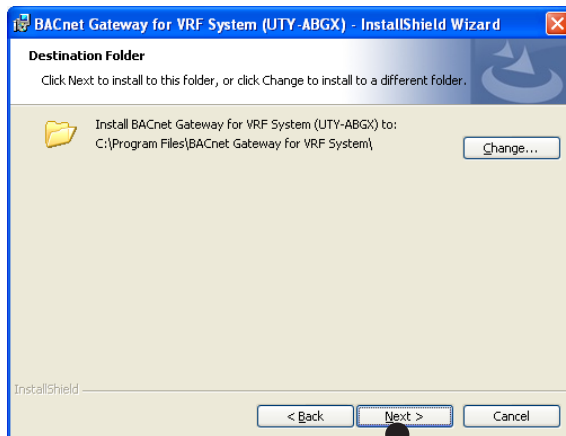

- ⑨ If the installation setting contents are correct, click the “Install” button.

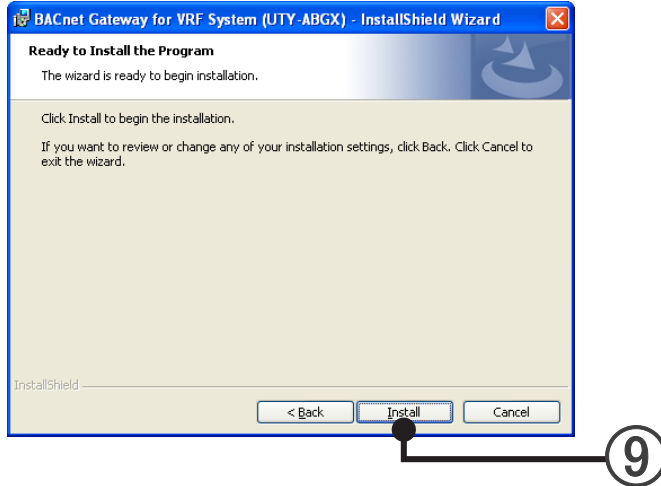

Installation starts.
The necessary drivers are also installed at the same time.

- WIBU-KEY driver

- ⑩ A description of WIBU-KEY Setup is displayed. Confirm the contents. Click the “Next” button.

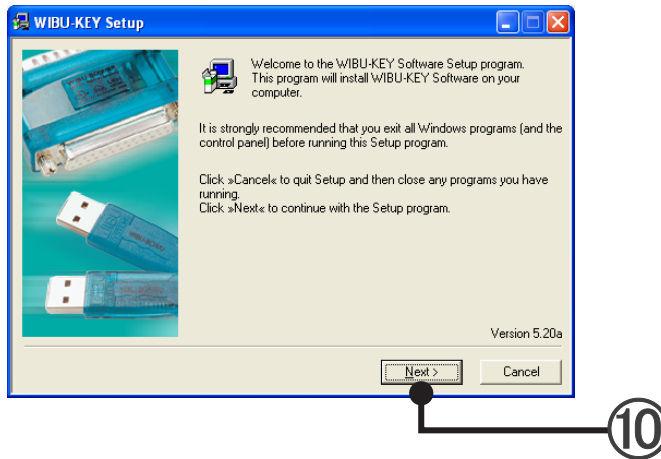

- ⑪ Select the language.
Check the desired language.

- ⑫ Click the “Next” button.

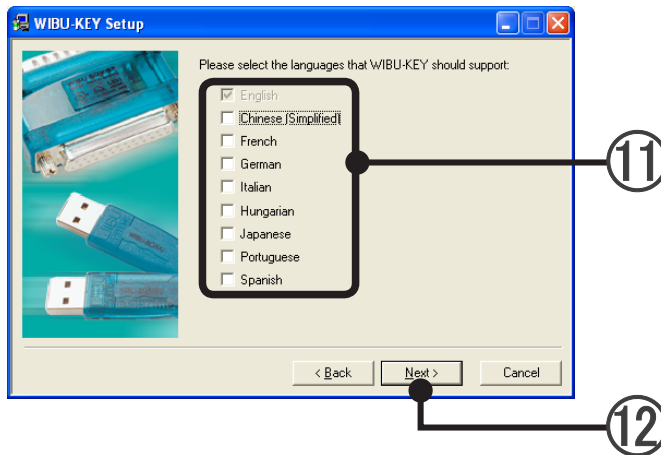

- 13 When the screen to specify the installation “Destination Folder” is displayed, specify the installation “Destination Folder” and click the “Next” button.

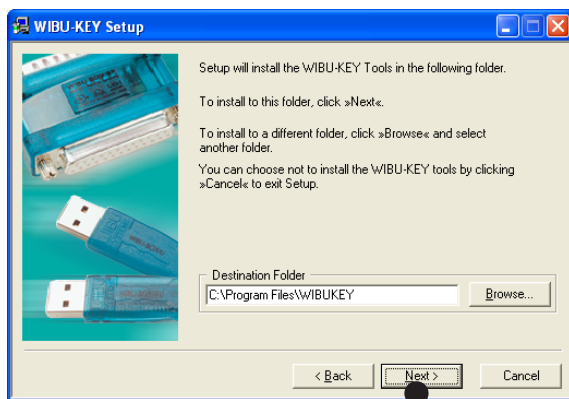

- 14 Click the “Yes” button.

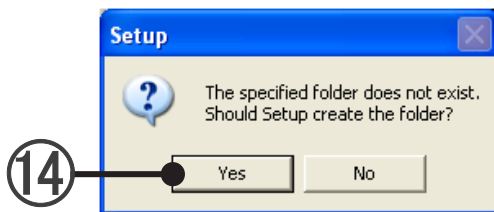

- 15 The WIBU-KEY components selection screen is displayed. Uncheck all the checkboxes and click the “Next” button.

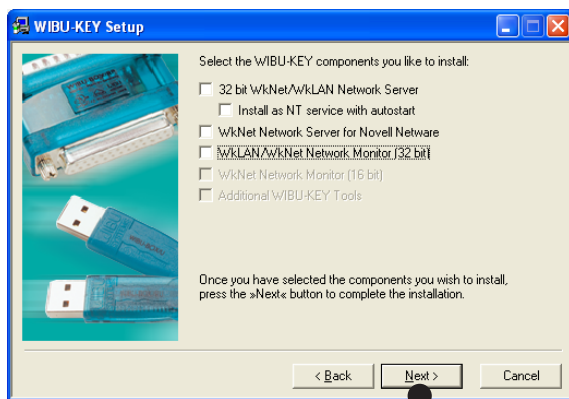

- 16 If the WIBU-KEY driver installation contents are displayed, confirm the contents and click the “Next” button.

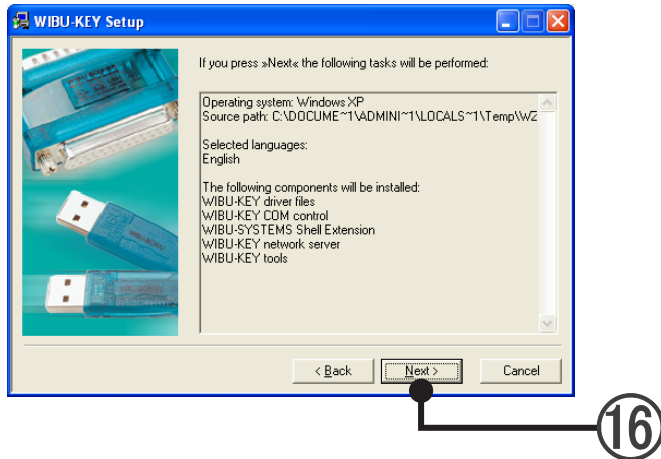

- 17 Installation starts.
When “Next” button is enabled, click the “Next” button.

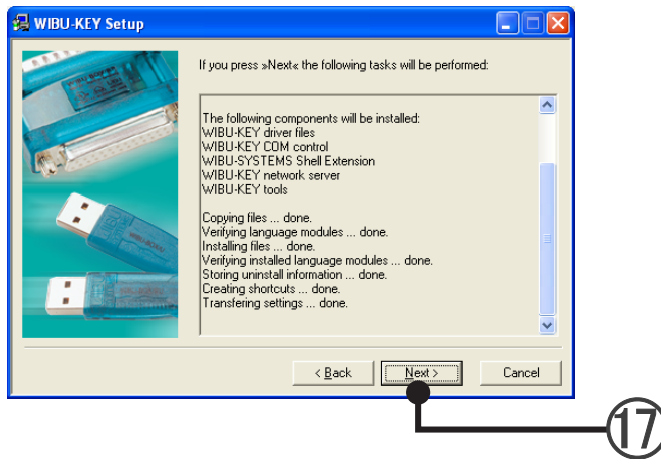

- 18 WIBU-KEY Setup is complete.
Uncheck the checkbox and click the “Finish” button.

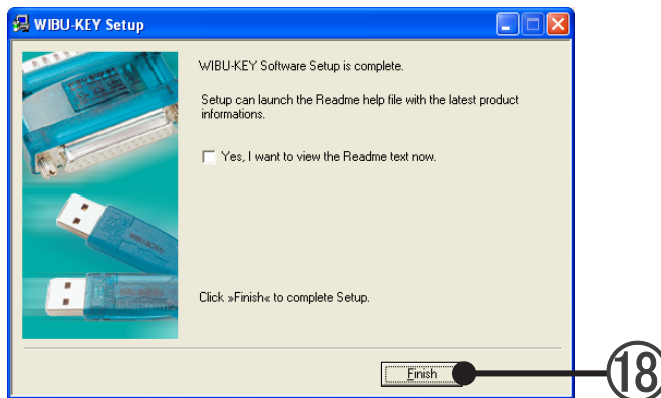

- 19) WIBU-KEY Setup was successful.
Click the "OK" button.

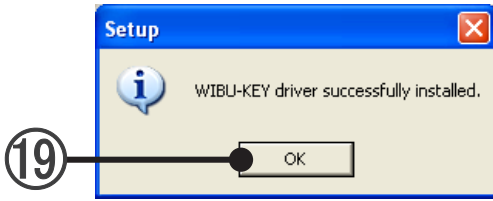

- 20) A message appears saying whether or not you want to start the BACnet® Gateway automatically.

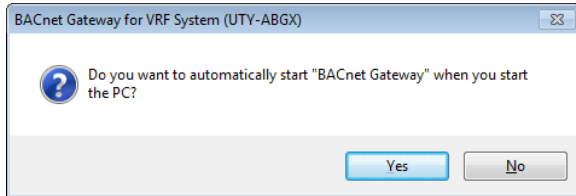

When the "Yes" button is clicked, the BACnet® Gateway is registered at the following location and automatically starts when the PC is booted.

For VISTA/7: The BACnet® Gateway is registered at the task scheduler.

When deleting, start the task scheduler and delete.

Control Panel - Administrative Tools - Task Scheduler

For XP: Shortcut is created at Startup.

When deleting, delete the shortcut files of the following folders:

C:\Documents and Settings\Administrator\Start Menu\Programs\Startup

VISTA/7

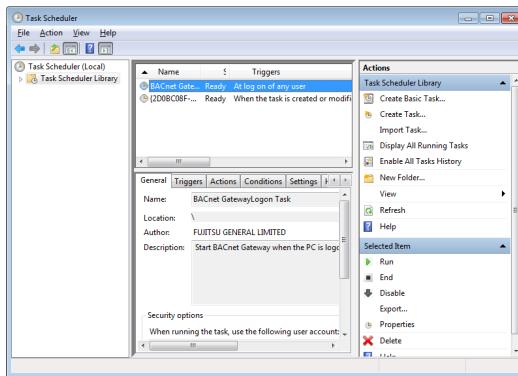

XP

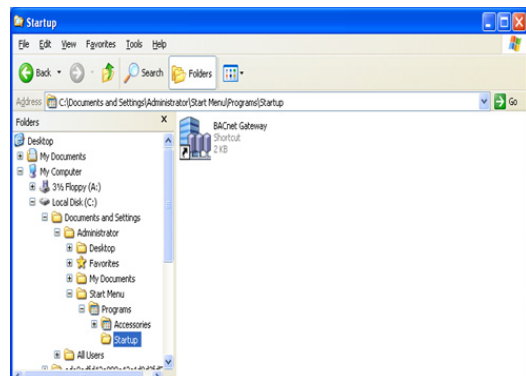

- ②① If this screen is displayed, installation of the BACnet® Gateway for VRF System to the PC is complete. Click the “Finish” button



- ②② After the end of installation, reboot the PC. Click the “Yes” button.

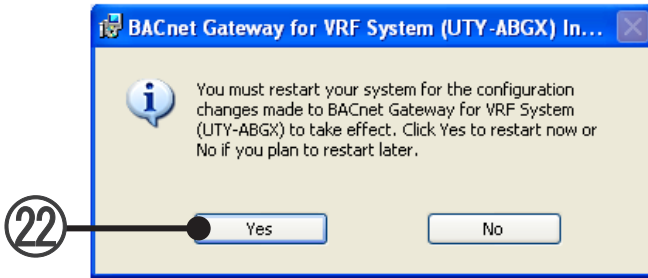

- ②③ After reboot the PC, connect the WIBU-KEY and the U10 USB Network Interface adaptor to USB port of the PC.

5-4 Software Uninstallation

When uninstalling the software from PC, follow the procedures shown below.

When you intend to reinstall BACnet® Gateway later, export “All Data” at this point.
→8-3-3 “All Data Export”

5-4-1 BACnet® Gateway Uninstallation

5-4-2 WIBU-KEY Driver Uninstallation

5-4-3 Microsoft® SQL Server® 2008 R2 Uninstallation and Native Client Uninstallation

5-4-1 BACnet® Gateway Uninstallation

Note

- When you need to keep the data for later use, export the data before uninstalling the BACnet® Gateway.
Write all the data by exporting. → 8-3 “Data Import/Export”

- Select the menu items in order of “start”→“Control Panel”→“Program and Features”.
- Select the “BACnet® Gateway for VRF System (UTY-ABGX)”.
- Click the “Uninstall” button.

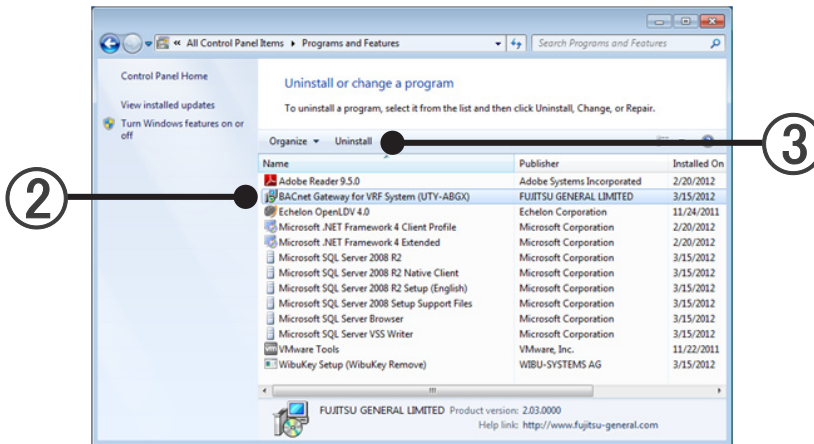

- When the “Yes” button is clicked, uninstallation begins.

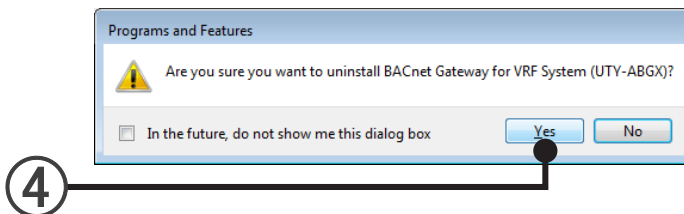

- When the screen displaying the uninstallation process closes, uninstallation is complete.
- Close the “Program and Features” screen by clicking the [x] at the top right-hand corner of the screen.
* A folder named the BACnet® Gateway remains in the folder designated the BACnet® Gateway installation folder at installation even though uninstallation is performed.
There is no problem even if this folder remains as is, but it doesn’t matter if the folder is deleted.

5-4-2 WIBU-KEY Driver Uninstallation

Execute only when you know for certain that the WIBU-KEY driver is not used by programs other than the BACnet® Gateway.

If unknown, do not uninstall the WIBU-KEY driver

Remove WIBU-KEY from the PC before uninstalling it.

- ① Select the menu items in order of “start”→“Control Panel”→“Program and Features”.
- ② Select “WIBU-KEY Setup (WIBU-KEY Remove)”.
- ③ Click the “Uninstall/Change” button.

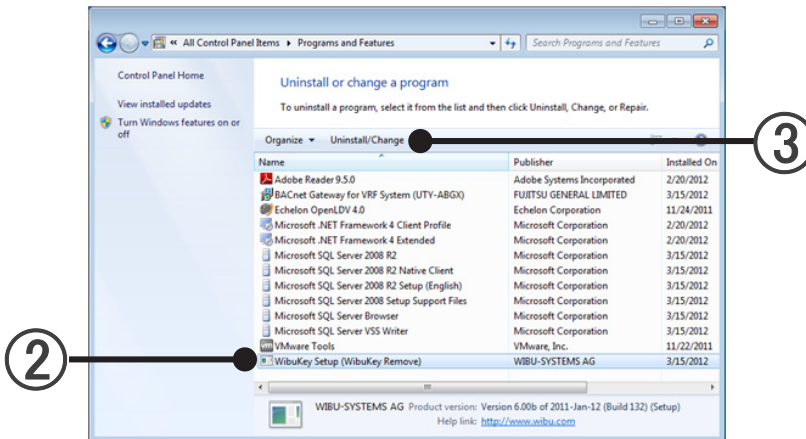

- ④ Click the “Next” button.

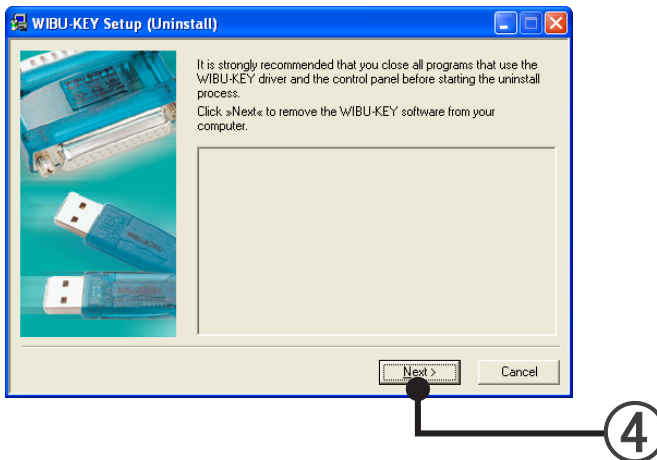

- ⑤ Check “Ignore, Setup will replace file at system startup (reboot required).”

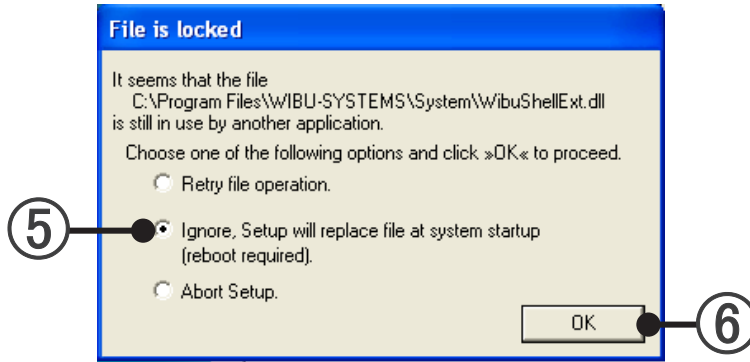

- ⑥ Click the “OK” button.
- ⑦ When this screen is displayed, uninstallation of the WIBU-KEY driver is complete. Click the “Finish” button.

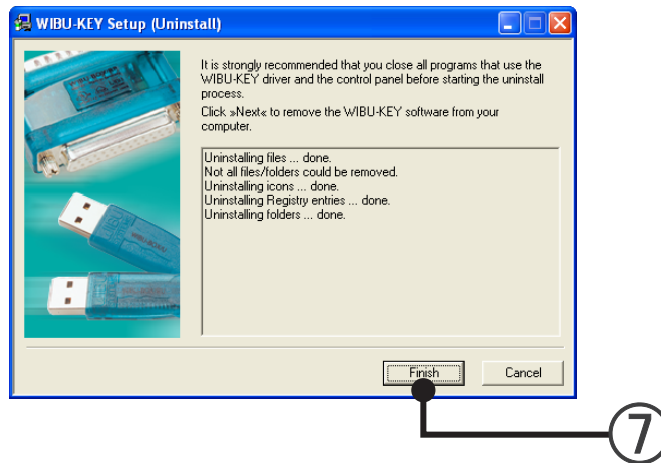

- ⑧ Close the “Program and Features” screen by clicking the [x] at the top right-hand corner of the screen.

5-4-3 Microsoft® SQL Server® 2008 R2 Uninstallation

Execute only when you know for certain that Microsoft® SQL Server® 2008 R2 is not used by programs other than the BACnet® Gateway.

If unknown, do not uninstall the program.

- ① Select the menu items in order of “start”→“All Programs”→“Microsoft SQL Server 2008 R2”→“Configuration Tools”→“SQL Server Configuration Manager”.
- ② Select “SQL Server Services”.
- ③ Right-click “SQL Server (SQLEXPRESS)”.
- ④ Select “Stop”.
- ⑤ When [x] is clicked, “SQL Server Configuration Manager” is completed.

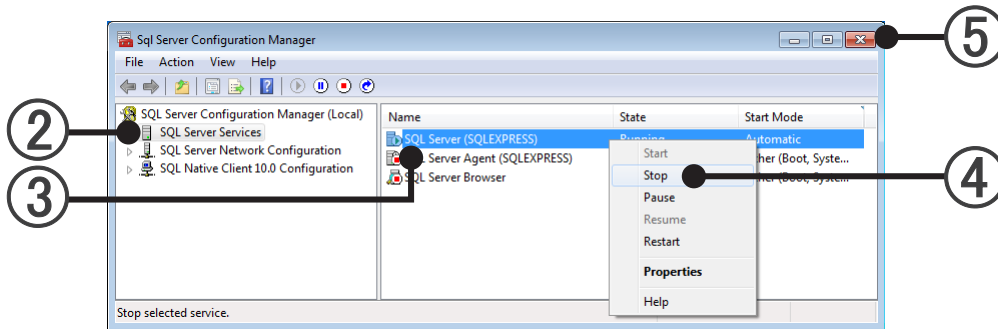

- ⑥ Select the menu items in order of “start”→“Control Panel”→“Program and Features”.
- ⑦ Select “Microsoft SQL Server 2008 R2”.
- ⑧ Click the “Uninstall/Change” button.

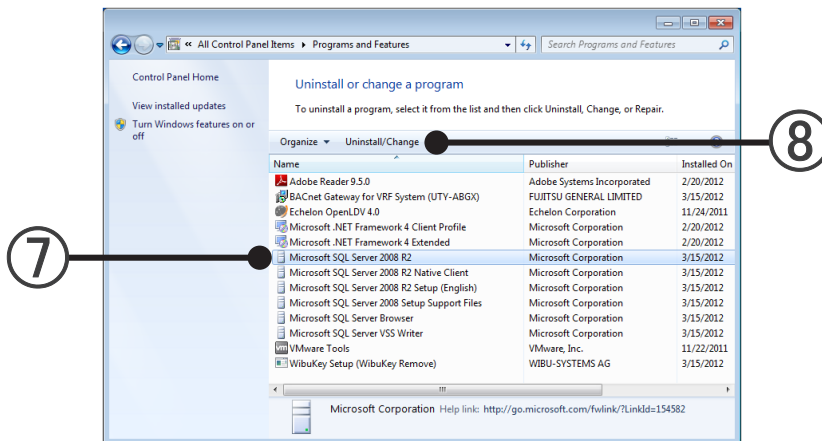

- ⑨ After this, follow the instructions on the screen.
For details, refer to the Microsoft website.
- ⑩ When uninstall is ended, uninstall "Microsoft SQL Server Native Client" in the same manner

Settings

6. Basic Settings
7. Electricity Charge Apportionment (ECA) Setting

6. Basic Settings

In this section, the basic settings necessary before use in the PC are explained. The settings that are also necessary when equipment configuration changes are also explained here.

When starting the system for the first time after installation, make the settings in accordance with the flow described below. At the 2nd and subsequent starting, make the necessary settings in accordance with subsequent paragraphs, as required.

6-1 When Starting for the First Time

When starting the BACnet® Gateway for the first time, perform the settings in accordance with this flow.

- Setting for First Time Use

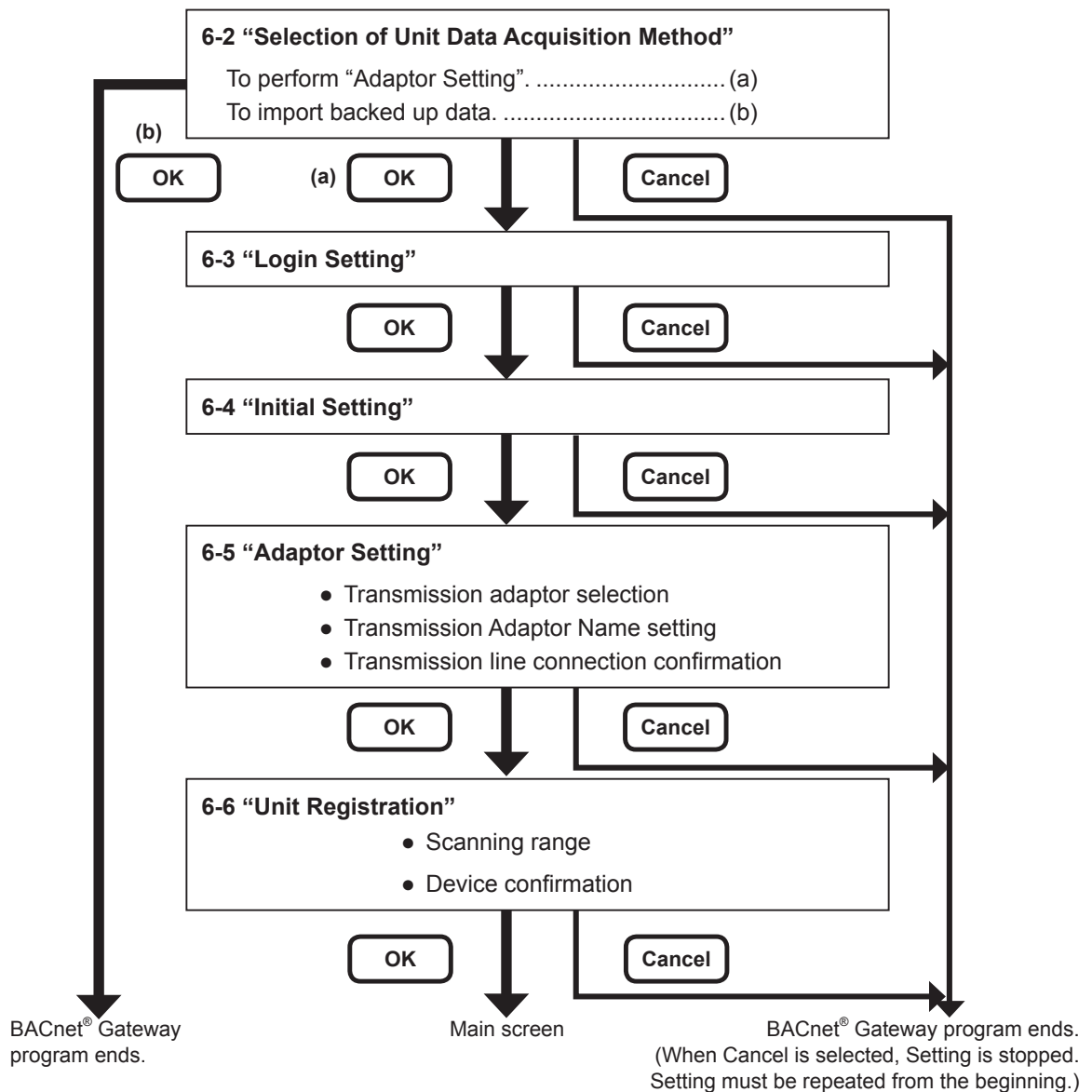

- Items Which Can Be Arbitrarily Set

- 6-7 "Description Property Setting"
- 6-8 "Change Password"

6-2 “Selection of Unit Data Acquisition Method”

This setting is performed only at first start settings.

- ① To perform 6-5 “Adaptor Setting” processing, select (a).
To import backed up data, select (b).
- ② Click the “OK” button.

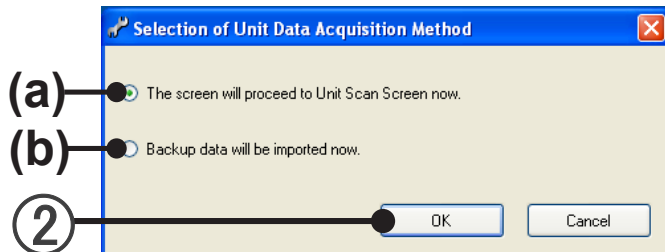

6-3 "Login Setting"

This setting is performed first start settings.

- ① Login ID
Enter the administrator's login ID.
(Within 20 characters of alphabet and numeric)
- ② Password
Enter the administrator's Password.
(Within 20 characters of alphabet, numeric, and symbol)
Password can be changed. See 6-8 Change Password.
- ③ Password Confirmation
Enter the administrator's Password again for confirmation
- ④ Omit Login screen at startup
When checked, the password input screen is omitted when the application is started from the next time.
At the end of an application, at DB importing, etc. the password input screen is displayed the same as up to now.
This setting can be changed by 6-4 Initial Setting screen and 6-8 Change Password screen.

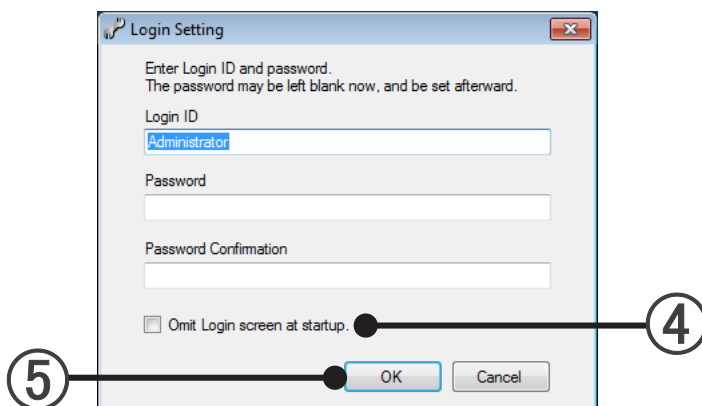

- ⑤ Click the “OK” button.

6-4 “Initial Setting”

Makes any settings and changes necessary before operation.

- ① When you want to reset Initial Setting, open the “Initial Setting” screen.
Select the menu items in order of “Setting” → “Initial setting” from the Menu bar.

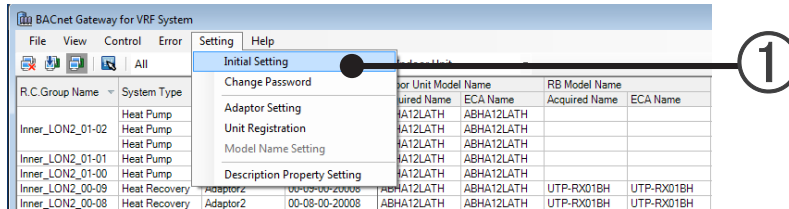

- ② Input or check each item of the screen shown below.
Always set “IP Address” and “Subnet Mask”.
Change other items as required.

When “Omit Login screen at startup” is checked, the password screen is omitted at application starting from the next time.

At the end of an application, at DB importing, etc. the password input screen is displayed the same as up to now.

- ③ Click the “OK” button.

Items	Contents
"IP Address"	Enter the IP address used in BACnet® communications. (IPv4 only)
"Subnet Mask"	Enter the subnet mask corresponding to the IP address used in BACnet® communications.
"Device Instance No."	Enter the Instance No. of the local Device.
"Device Object Name"	Enter the object name of the local Device. (Up to 50 ASCII characters)
"Max_APDU_Length_Accepted"	Select the acceptable APDU length.
"APDU_Timeout (m sec)"	Enter the APDU timeout time in milliseconds.
"Number_of_APDU_Retries"	Select the number of retries when time out occurs.
"APDU_Segment_Timeout (m sec)"	Enter the internal time at which APDU segment is resent, in milliseconds.
"I-Am Service Broadcast Sending (at 60-second intervals)"	Check when you want to send I-Am Service periodically. (60-second intervals)
"Unconfirmed COV Notification Service Broadcast Sending"	COV notification is sent by broadcast even when SubscribeCOV service is not subscribed. Refer to the interface specifications for the target object. * Depending on the number of units and their status, large number of packets are sent.
"Process ID"	Process ID used when sending COV notification.
"Synch. VRF System Time to Time Synchronization/UTCT Time Synchronization."	Check if you want to send "system time setting" to VRF units when TimeSynchronization/UTCTimeSynchronization Service is received.
"Register as Foreign Device with BBMD"	Check when you register as an external device to BBMD.
"BBMD at IP Address"	BBMD IP address.
"BBMD at UDP Socket"	BBMD UDP port No.
"Temperature Units" *1	"Celsius" or "Fahrenheit" can be selected. Select the units to be used at temperature display.
"Capacity Units"	"BTU" or "kW" can be selected. The selected unit will be used for displaying the capacity values in the main screen.
"Omit Login screen at startup"	When "Omit Login screen at startup" is checked, the password screen is omitted at application starting from the next time. At the end of an application, at DB importing, etc. the password input screen is displayed the same as up to now.

Also, the following property values of the following objects will be converted automatically.

*1	Property Identifier	For CELSIUS	For FAHRENHEIT
AI_Object	Present_Value	CELSIUS Temperature	FAHRENHEIT Temperature
	Units	DEGREES-CELSIUS	DEGREES-FAHRENHEIT
	High_Limit	Default:30.0	Default:88.0
	Low_Limit	Default:10.0	Default:48.0
AO_Object	Present_Value	CELSIUS Temperature	FAHRENHEIT Temperature
	Units	DEGREES-CELSIUS	DEGREES-FAHRENHEIT
	Priority_Array	CELSIUS Temperature	FAHRENHEIT Temperature
	Relinquish_Default	Default:26.0	Default:80.0
	High_Limit	Default:30.0	Default:88.0
	Low_Limit	Default:10.0	Default:48.0

Notes on the temperature unit setting screen

Temperature unit can only be selected from this screen. It is not possible to change the temperature unit from BMS.

The temperature unit should not be changed during operation. If changed, the user must notify the BMS of the change.

6-5 “Adaptor Setting”

Sets the Device Name and confirms the Device State of the Transmission adaptor (U10 USB Network Interface) that connects the “BACnet® Gateway”.

- ① When you want to reset “Adaptor Setting”, open the “Adaptor Setting” screen. Select the menu items in order of “Setting”→“Adaptor setting” from the Menu bar.

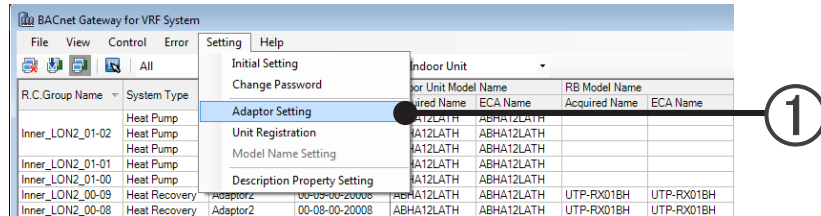

- ② The Adaptor Name can be set for easy identification by the user. Click the Adaptor Name you want to set and enter the text. (Default name: “AdaptorX”) Up to 20 characters (alphabet, numeric, and symbol) can be set. The Adaptor Name cannot be duplicated. Only the connected adaptor can be set.
- ③ Usable device setting and confirmation are possible.

“Device”	Name	A usable devices list (LONx) or “Not Used” can be pulled down and selected.	
	“Status”	Displays the device status.	
		“Ready”	The specified adaptor can be used.
		“Busy”	The specified adaptor is being used by another system.
		“Error”	The specified adaptor cannot be used.
(Blank)	Not displayed when an adaptor is not connected.		
“Check”	When the “Wink” button is clicked, the SVC lamp of the specified device lights (for approx. 2 second) and you can confirm which Transmission line the adaptor is connected to. (Only when the Device Status is Ready)		

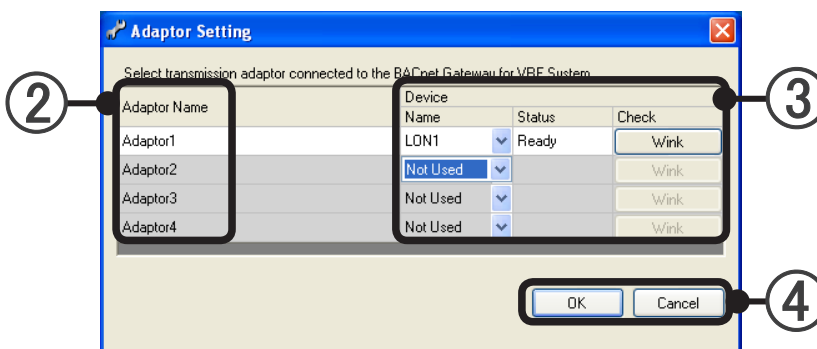
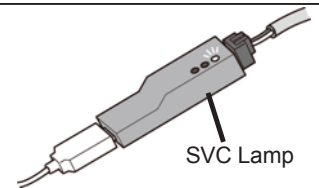

- ④ “OK”: Saves the settings and ends setting work.
“Cancel”: Ends setting work without saving the settings.

Note

Adaptor Name is a name which can be arbitrarily set so that the user can easily identify connection of the Transmission adaptor (U10 USB Network Interface). (Default name: “AdaptorX”)

“Device Name” is a name automatically allocated to the network when a “Transmission adaptor” (U10 USB Network Interface) is connected. (User may select the LONx number)

6-6 “Unit Registration”

Scans by the network and detects and registers usable R.C. groups and outdoor units. The units registered by scanning are managed by BACnet® Gateway.

- ① When you want to reset “Unit Registration”, open the “Unit Registration” screen. Select the menu items in order of “Setting”→“Unit Registration” from the Menu bar.

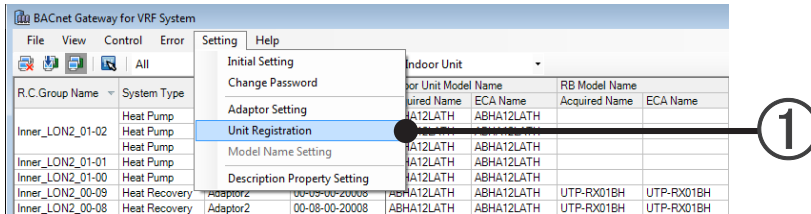

- ② Set the scan Targets.
Scan targets

“Adaptor Name”	Selects the name of the adaptor which is to perform scanning. (Name set at par. 6-5 “Adaptor Setting”) Unit Registration is necessary for each adaptor. When an adaptor is set at a blank line, a blank line is added below it. The same adaptor can be set on multiple lines and different refrigerant system can also be specified.	
	“Secure Reg.”	
Specifies by checkbox whether or not secure registration is to be performed when scanning Checked: Secure registration (Recommended) Not checked: No secure registration When scanning is performed by secure registration, operation of the units is stopped. When you do not want to stop operation, uncheck the checkbox. See par. 11-1 No.4.		
“Ref. No.”	“Start”	When partially scanning, specify the start number of the refrigerant system by pull-down menu or key input. See par.11-1 No.8.
	“End”	When partially scanning, specify the end number of the refrigerant system by pull-down menu or key input.
“Device”	“Name”	Displays the name of the device used by the relevant network.
	“Status”	Displays the status of the device used by the relevant network. Normal: “Ready” Abnormal: “Error” Not connected: “Blank”
	“Check”	When the (a) “Wink” button is clicked, the SVC lamp of the Transmission adaptor used by the relevant network lights (for approx. 2 second) and connection of the selected adaptor can be identified. (Effective only when the status of the Transmission adaptor is normal.)

Description of screen

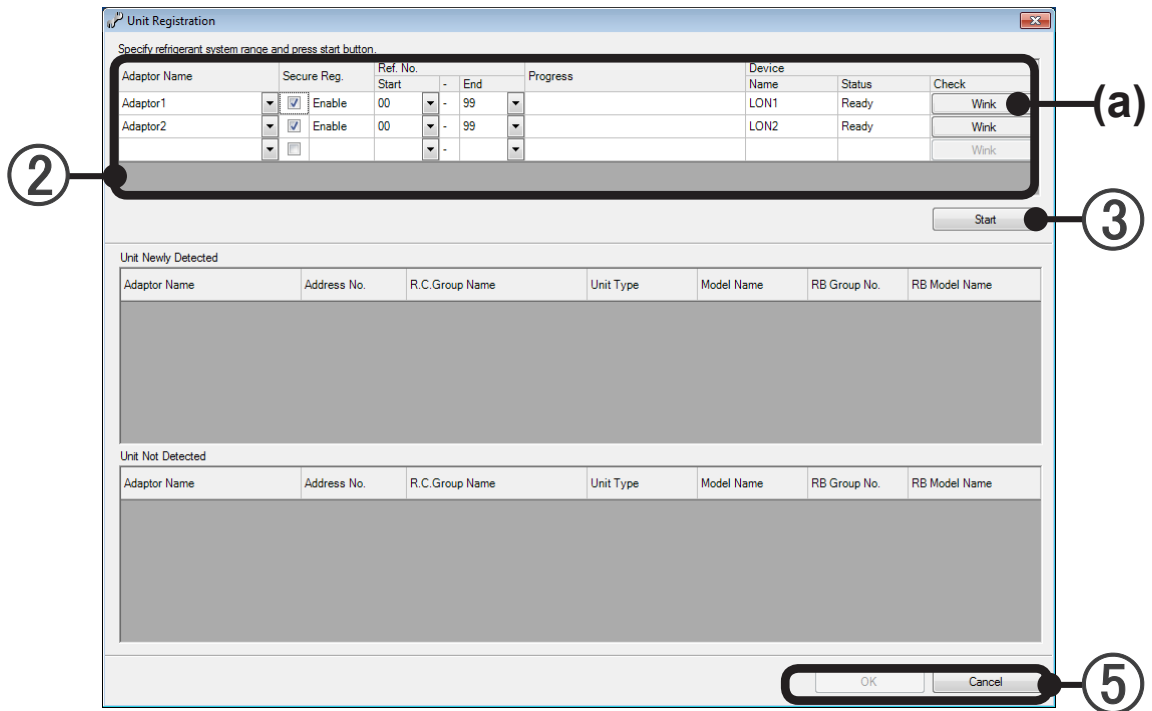

- ③ Click the “Start” button.
- ④ Click the “OK” button. (The following screen is displayed only when “Secure Reg” is checked.)

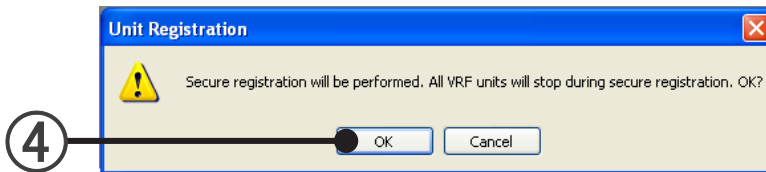

Starts scanning. (Disabled when there is no scanning target.)

The time required by scanning differs with the size of the system. Use the indicator displayed at (b) during scanning as a guideline.

While scanning is being performed, the “Stop” button (c) is displayed. To stop scanning, click this button.

Note

All systems connected to 1 Transmission adaptor (U10 USB Network Interface) are stopped during scanning for secure reg.

VRF network list display during scanning

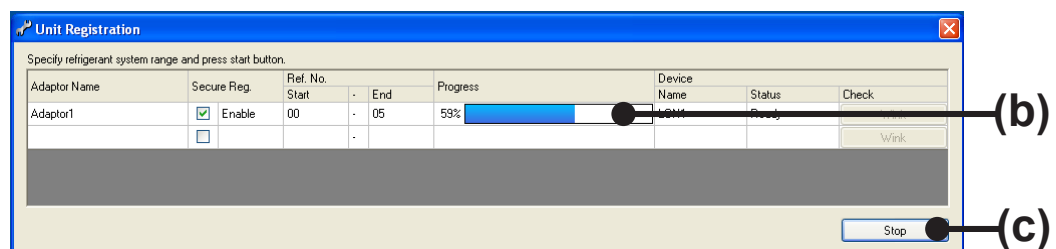

When scan ends, “Done” is displayed at the progressive bar display.

Note

If the following message is displayed after scanning is completed, the necessary information cannot be acquired.

"Information was not acquired for some units. Perform unit registration again."

In this case, always perform scan again to acquire all the necessary information.

If advanced to next as is, normal operation will become impossible.

Especially, if there is a unit for which information could not be acquired when electricity charge apportionment is performed, the refrigerant system including that unit will not be handled by the electricity charge apportionment function.

When these information missing units are included in "Unit Newly Detected", since they are displayed in red characters, treat them as the index of refrigerant system specification when rescanning.

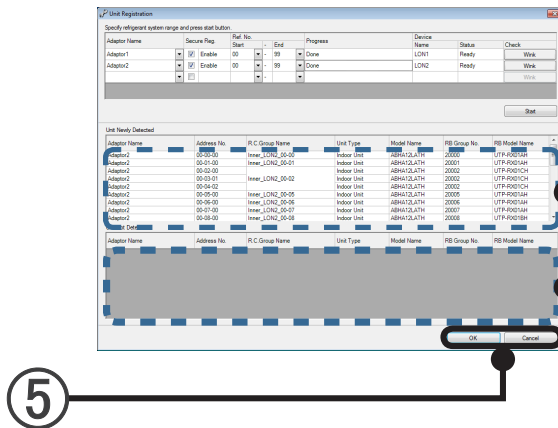

“Unit newly detected” list:

After the end of scanning, displays the units newly detected.

At initial scanning, all the units are displayed.

After the 2nd scanning, only the units newly detected are displayed.

Model names for S/V series will not be displayed.

“Unit not detected” list:

When scanning was performed for the 2nd and subsequent times, displays the units which are already registered but were not detected this time.

Note

- As a result of performing scan, a unit of the same address may be displayed in the “Unit Newly Detected” list and “Unit not detected” list.

This occurs when a registered unit was changed to a different model and set to the same address as the previous unit, etc.

Since the registration information of the previous unit is erased when registration is completed, continue at that setting.

- When intentionally removing a unit from registration, etc, because the unit is removed from the electric power charge apportionment objective or other reason, confirm it here. (Perform scanning after turning off the power of the unit removed from registration.)
- Depending on the R.C. connected to the indoor unit, "R.C. address" part of the "Address No." column may show different value from that being set to the indoor unit.

The same applies to the "Address No." and "Address" column of other screens.

The numbers in the "Address No." corresponds to "Refrigerant system address" - "Unit address" - "R.C. address".

- ⑤ “OK” button: Saves the detected unit configuration detected by scanning.
- “Cancel” button: Ends scanning without saving the scanned result.

6-7 “Description Property Setting”

Values of description properties of all objects within the selected unit can be modified at once.

- ① Select the menu items in order of “Setting”→“Description Property Setting” from the Menu bar.

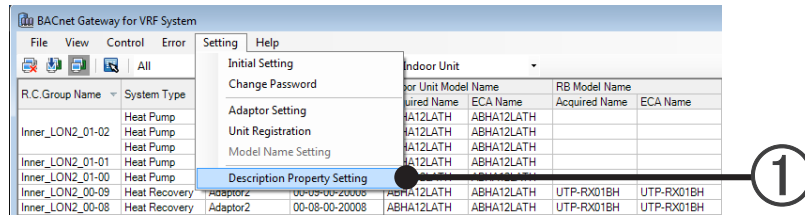

- ② Up to 50 characters can be entered.

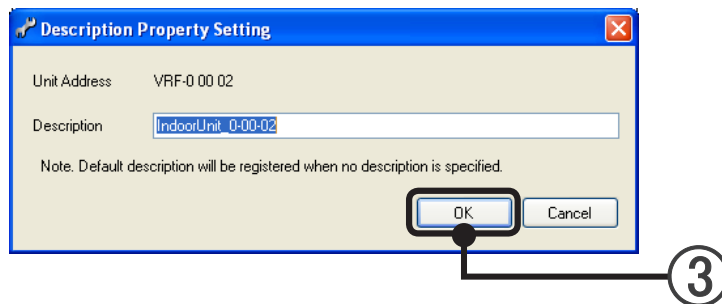

- ③ Click the “OK” button.

6-8 "Change Password"

Change the password.

- ① Select the menu items in order of "Setting"→"Change Password " from the Menu bar.

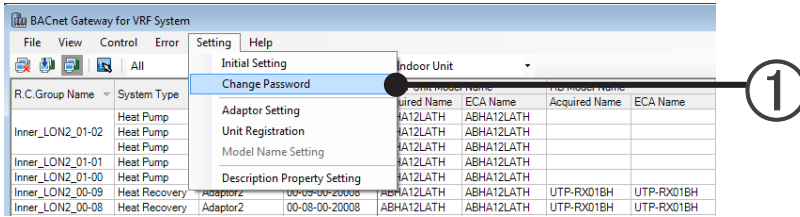

- ② Enter the current password.
- ③ Enter the new password.
(Within 20 characters of alphabet, numeric, and symbol)
- ④ Enter the new password again for confirmation.

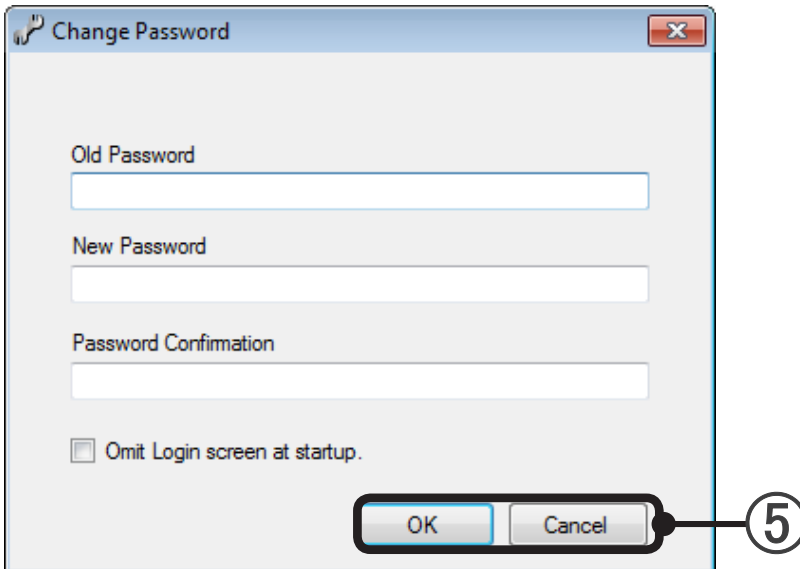

When "Omit Login screen at startup" is checked, the password screen is omitted at application starting from the next time.

At the end of an application, at DB importing, etc. the password input screen is displayed the same as up to now.

- ⑤ "OK" button: Saves the new password.
"Cancel" button: Ends without saving the revised contents.

7. Electricity Charge Apportionment (ECA) Setting

Performs basic settings related to electricity charge apportionment necessary before operation. You may also update the settings due to facility and tenant changes.

At initial starting after installation, perform setting in accordance with the following flow. For settings and changes after operation starts, perform the necessary settings in accordance with the contents of par. 7-2 and subsequent paragraphs.

7-1 Basic Setting Flow

Perform initial setting in accordance with this flow.

7-2 Understand electricity charge apportionment and confirming caution items.

7-3 "Model name setting"
Set all the places where Model Name of the main screen is displayed in red.

- Use ReadProperty Service or ReadPropertyMultiple Service from B-OWS to read the value of Present_Value property of the MI 0200000(ECA Status) object and confirm that it is "2".

- Use WriteProperty Service to write the command value at the Present _Value property of the MO 0100000 object from B-OWS.
 - 1:When ending electricity charge apportionment data collection
 - 2:When starting electricity charge apportionment data collecting by calculation including indoor units
 - 3:When stating electricity charge apportionment data collection by calculation not including indoor units

1. Purpose of electricity charge apportionment

The electricity charge apportionment function apportions air conditioner electricity charges to tenants. Generally, indoor units are divided among and used by each tenant, and calculation of the electricity charge for each tenant is easy. But since outdoor units are shared by multiple tenants, calculation of the electricity charge for each tenant is not easy.

The electricity charge apportionment function allows distribution of the electricity charges of outdoor units, which are a large part of the air conditioner power consumption, according to the air conditioner usage of each tenant.

2. Features of electricity charge apportionment of BACnet® Gateway

- (1) Power meter is not used and electricity apportionment calculation is performed from the electricity charges billed from the electric power company.
- (2) Apportionment calculation is performed according to indoor unit usage.
- (3) In addition to electricity charge calculation of outdoor units only, electricity charge calculation including indoor units is also possible.
- (4) In case of heat recovery system(VR-II series), power consumption of RB units may be also be included in the calculation.

3. Precautions for Using Electricity Charge Apportionment Function

- (1) The electricity charge apportionment function requires correct setting and use in accordance with the descriptions in this manual and Interface Specification Manual.
If correct operation based on correct setting is not performed, a reasonable result may not be obtained.
- (2) The electricity charge apportionment function does not calculate official electricity charges like those established by the laws and regulations of each country.
- (3) Gaining an understanding of the descriptions, etc. in this manual and using the electricity charge apportionment function accordingly should be performed by the responsibility of the user.
- (4) The electricity charges used in electricity charge apportionment calculation should only be that of the power consumed by the air conditioner.
- (5) For the electricity charge apportionment function to function properly, BACnet® Gateway must operate continuously. If BACnet® Gateway is shut down or stopped by a power failure, etc. while the data needed by calculation is being acquired, correct electricity charge apportionment calculation may be not be possible.
- (6) Electricity charge apportionment is performed for units identified by scanning. When the unit configuration is changed, perform scanning to re-identify the target units.
- (7) Constantly maintain the units which are the target of electricity charge apportionment calculation in the normal operating state.
If it is turned off for a long time, etc., data acquisition and correct calculation may not be possible.
- (8) The electricity charge for units or refrigerant systems which are the target of electricity charge apportionment calculation are calculated even when it is turned off. To remove them from electricity charge apportionment calculation, turn off the power of the unit or refrigerant system which is to be removed and re-scan to remove the unit from the calculation target.
- (9) Electricity charge apportionment calculation identifies units by address. When the address of a unit was changed by automatic addressing function, etc., perform scanning to re-identify the correct address.
- (10) Even when an indoor unit operation time is zero, the rate (proportion) of the electricity charge apportionment is not zero because of the power consumed in the outdoor unit in standby.
- (11) The apportionment calculation for the electricity charge cannot be performed for air conditioners other than VRF, such as single split type, that are connected to the VRF System via convertors.

- (12) The S/V series and V-II/J-II/VR-II series adopt different refrigerant system control and the electricity charge apportionment function adopts different method reflecting the difference. So the same operation condition for units may not yield the same result for S/V and V-II/J-II/VR-II series.
- (13) The electricity charge apportionment function of VRF system can only be performed from 1 controller or 1 gateway simultaneously.

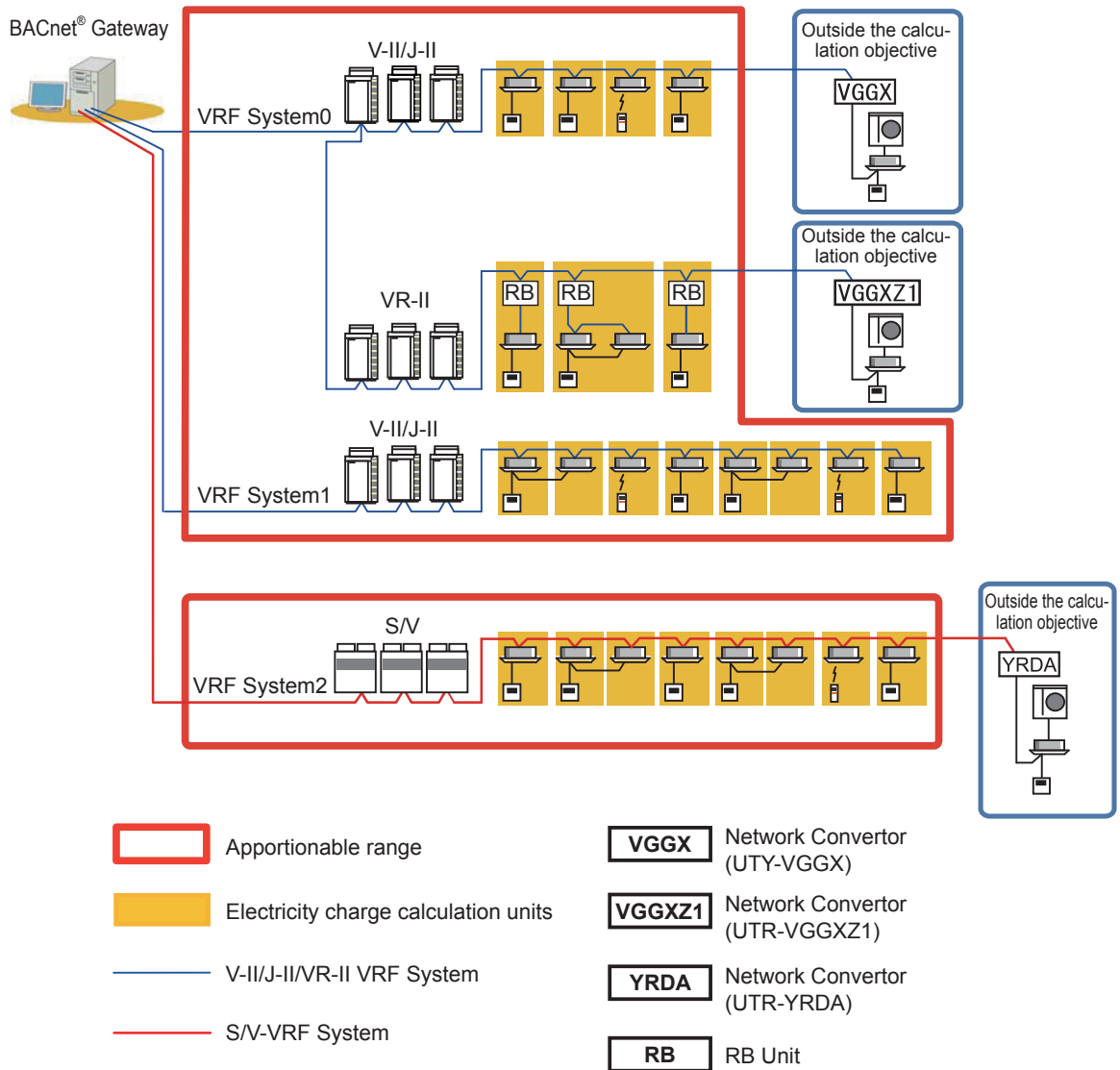

4. Electricity charge apportionment error

Errors and their main causes related to electricity charge apportionment, detected by the BACnet[®] Gateway are described.

(1) Generation conditions

Generated when a unit that does not send the information necessary for electricity charge apportionment (non-communicating unit) is detected during the period electricity charge apportionment data collection is performed.

Judgment, performed for the outdoor unit and the indoor unit, is based on whether there is no communication for more than 30 minutes or not.

(2) Processing of errors by BACnet® Gateway

- Electricity charge apportionment error with the unit address are displayed for the non-communicating unit.

The generation time and recovery time are recorded in the error history as with the other errors.

- In the electricity charge apportionment calculation, non-communicating unit is handled the same as an indoor unit whose operation is stopped by a remote controller.

(3) Recovery conditions

When the data necessary for electricity charge apportionment can be acquired from the relevant unit, the electricity charge apportionment error is reset.

(4) Main error generation causes

- Electricity charge apportionment errors are mainly generated when the power breaker of a unit is switched off.

(Because apportionment data is not sent when the power breaker is switched off.)

When the power breaker of only part of the units in a refrigerant system is switched off, outdoor unit trouble may occur.

Therefore, if there is a unit whose power breaker is switched off, quickly recover the power by switching on the breaker.

7-3 “Model Name Setting”

Model Name is automatically acquired at scanning.

When the data was collected normally, Model Name is Displayed at “Acquired Name” and “ECA Name”.
When the data could not be collected normally, Model name is displayed in red. In this case, set Model Name individually.

* S/V Series cannot obtain Model Name even by scanning. (This function cannot be used.)

- 1 Select the menu items in order of “Setting”→“Model Name Setting” from the Menu bar.

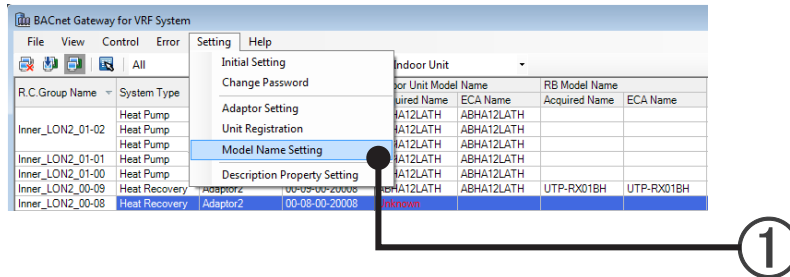

- 2 Select “Model Name”.

For the outdoor unit or indoor unit without any RB unit connected.

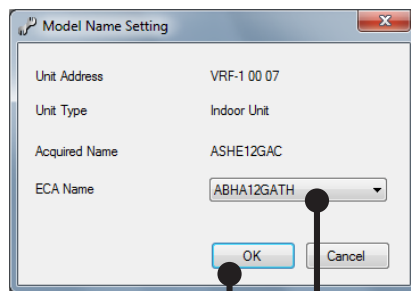

For the indoor unit with RB unit connected

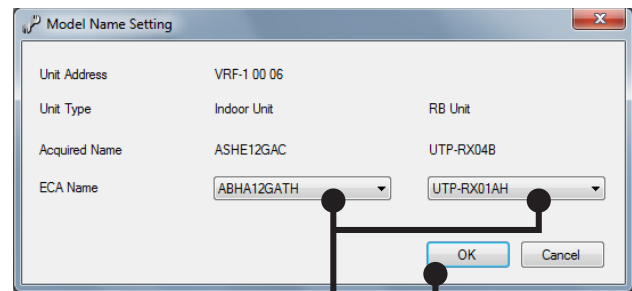

- 3 Click the “OK” button.

Operation

8. Operation

8. Operation

8-1 Starting and Ending the BACnet® Gateway

■ Starting the BACnet® Gateway

Make sure that USB Adaptor Connections (Refer to 5-2 Hardware Installation.) are completed and the Ethernet cable for the BACnet® Gateway is connected to LAN port of the PC before starting up the application.

- ① Select "BACnet® Gateway for VRF System" from the Windows start menu.

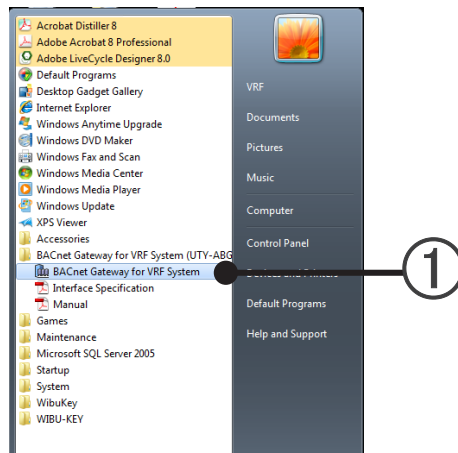

- ② Enter the Login ID.
- ③ Enter the Password.

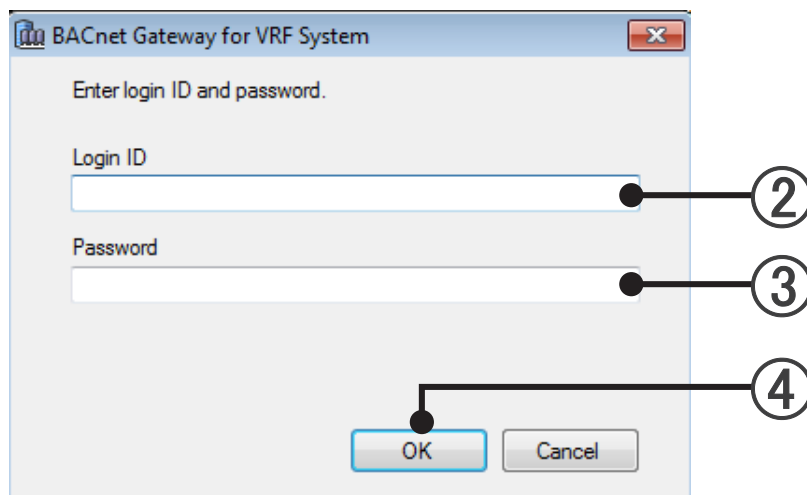

- ④ Click the "OK" button.
- ⑤ When "BACnet® Gateway for VRF System" boots up, the main screen is displayed. (Refer to 8-2 Main Screen.)

■ Ending the BACnet® Gateway

- ① Select the menu items in order of “File”→“Exit” from the Menu bar

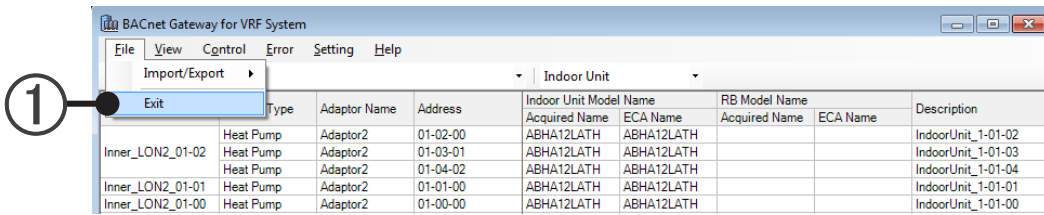

- ② Enter the Login ID.

- ③ Enter the Password.

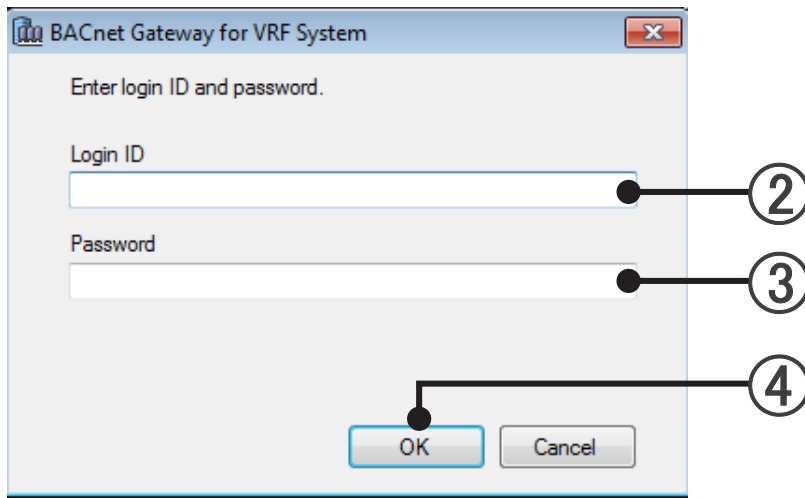

- ④ Click the “OK” button.

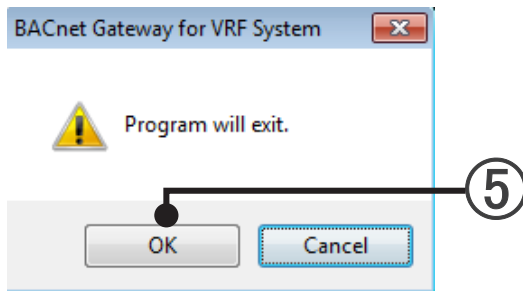

- ⑤ Click the “OK” button.

8-2 Main Screen

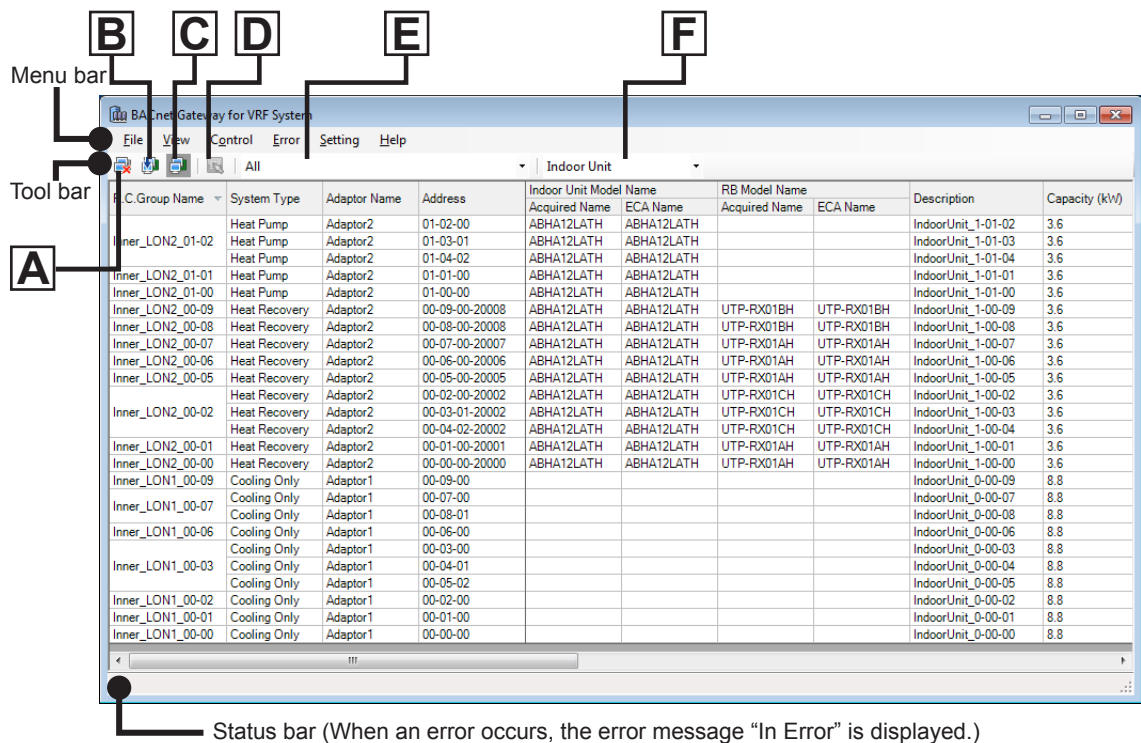

Status bar (When an error occurs, the error message "In Error" is displayed.)

This software has the following functions

	Menu bar (Command name)		Contents		Tool bar
1	"File"	"Import / Export"	"Unit List(EDE) Export"	Exports "Unit List(EDE)" data to a CSV format file.	-
			"All Data Import"	Imports the data backed up by "All Data Export".	-
			"All Data Export"	Backs up the internal data.	-
		"Exit"	-	The BACnet® Gateway ends.	-
2	"View"	"VRF System"	"All (All adaptors)"	Displays the Status information of all the indoor units or outdoor units connected to this system.	[E]
			"Adaptor**"	Displays the Status information of the indoor unit or outdoor unit of the selected adaptor. * A maximum of 4 adaptors can be connected. Menus for only the number of connected adaptors are displayed	[E]
		"Unit"	"Indoor Unit"	Displays the Status information of the Indoor Unit connected to the adaptor selected by [VRF System] menu.	[F]
			"Outdoor Unit"	Displays the Status information of the Outdoor Unit connected to the adaptor selected by [VRF System] menu.	[F]

		Menu bar (Command name)		Contents	Tool bar
3	"Control"	"Operation Setting"	-	The following setting screen of indoor unit is displayed. ①Operation "on/off" ②"Operation mode" switching ③"Set temperature" switching ④"Fan speed" switching (Outdoor Unit cannot be set.)	D
		"Device Communication Disable" (*1)	-	Device communications is disabled. * When this setting is performed, communication with the VRF System is not stopped.	A
		"Device Communication Disable_Initiation" (*1)	-	The initiation of communications is disabled. *When this setting is performed, communication with the VRF System is not stopped.	B
		"Device Communication Enable" (*1)	-	Communications is enabled.	C
		"Out of Service"	"False"	Set Out_Of_Service properties of all BACnet® objects to "False".	-
4	"Error"	"Error Notification"	-	Displays the current error information.	-
		"Error History"	-	Displays the error information history.	-
5	"Setting"	"Initial Setting"	-	Set when installing equipment. Refer to par. 6. Basic Settings.	-
		"Change Password"	-		-
		"Adaptor Setting"	-		-
		"Unit Registration"	-		-
		"Model Name Setting"	-		-
		"Description Property Setting"	-		-
6	"Help"	"Manual"	-	Instruction manual (this manual) is displayed.	-
		"Interface Specification Document"	-	Interface Specification Document is displayed.	-
		"Version Information"	-	Version information is displayed.	-

*1. About Device Communication Control Service

The 3 functions "Device Communication Disable", "Device Communication Disable_Initiation" and "Device Communication Enable" can be set for a Device itself. (Time Duration, Password cannot be set) This setting can be set from a BACnet® Device (B-OWS, etc.) This value can be overwritten from B-OWS.

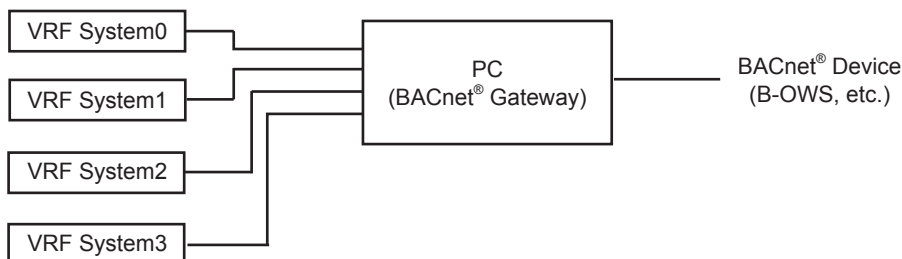

8-3 “Data Import/Export”

8-3-1 “Unit List (EDE) Export”

1. Description of function

Export “Unit List(EDE)” data to a CSV format file.

About “EDE”

The contents of “EDE “ sheet and “State-Texts” sheet of The Engineering Data Exchanger (EDE) template created by BACnet® Interest Group Europe is output in CSV format. In addition, the “set-table” field of the “EDE” sheet is not used.

2. Operating procedure

- ① Select the menu items in order of “File”→“Import/Export”→“Unit List (EDE) Export” from the Menu bar.

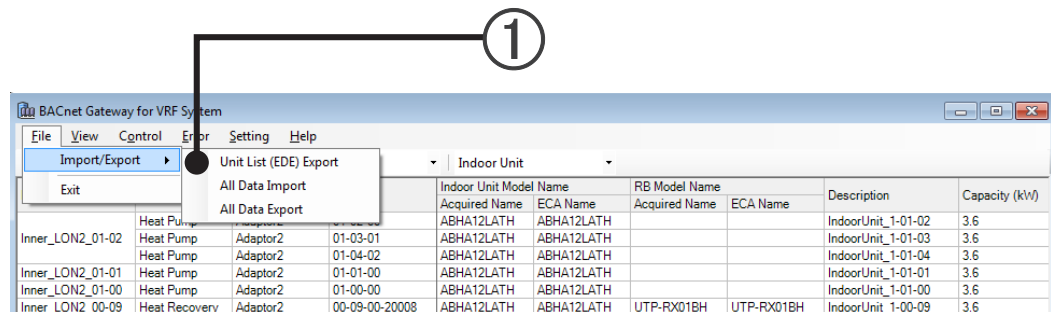

- ② Specify the Export destination folder and click “OK”.
The folder to be saved shall be created in advance.

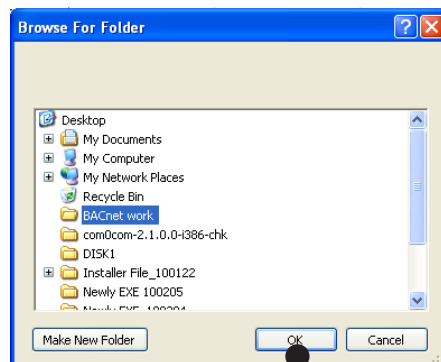

- ③ When “OK” is clicked, the export is complete.

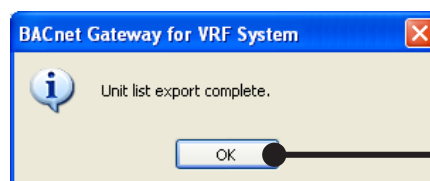

8-3-2 “All Data Import”

1. Description of function

Import the data backed up by “All Data Export”.

2. Operating procedure

- ① Select the menu items in order of “File”→“Import/Export”→“All Data Import” from the Menu bar.

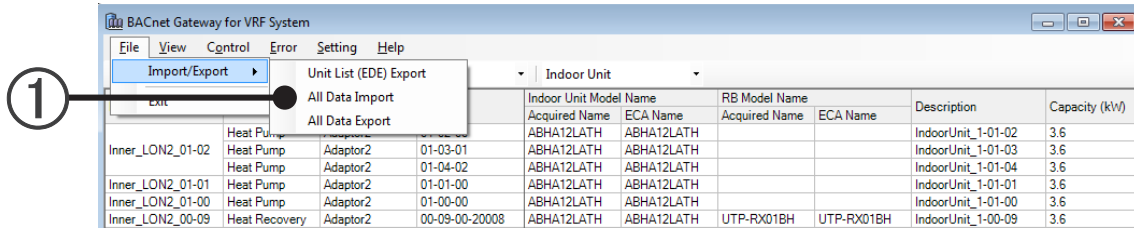

- ② Enter the Login ID.

- ③ Enter the Password.

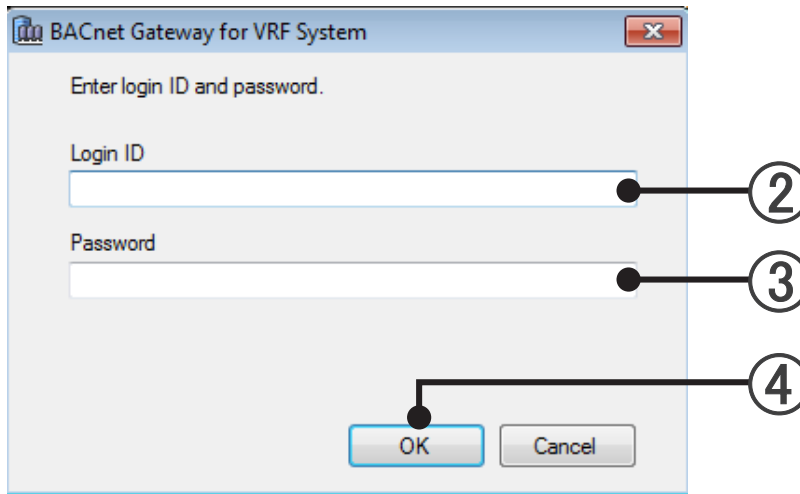

- ④ Click the “OK” button.

- ⑤ Specify the file to be imported and click “Open”.

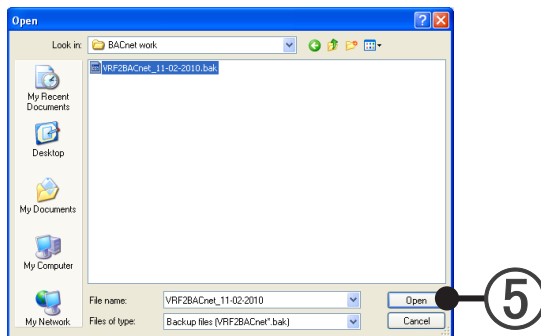

- ⑥ When “OK” is clicked, the import starts.

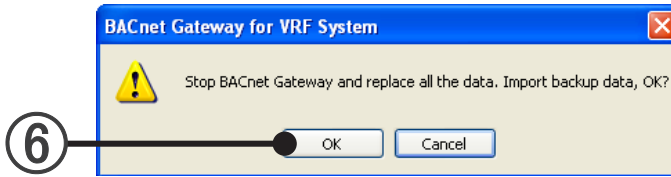

- ⑦ When “OK” is clicked, the import is complete.

- ⑧ After the main screen is closed, restart BACnet® Gateway.

8-3-3 “All Data Export”

1. Description of function

Back up the “All Data” (internal data).

All Data : Connected U10 USB Network Interface adaptor data, scanned unit data, and data set by B-OWS.

2. Operating procedure

- ① Select the menu items in order of “File”→“Import/Export”→“All Data Export” from the Menu bar.

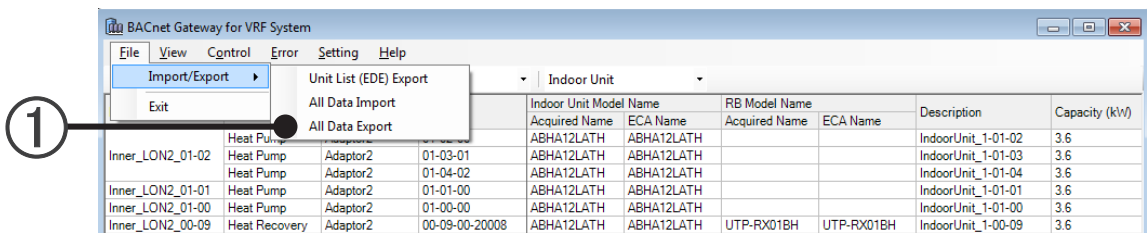

- ② Specify the export destination folder and click “OK”.
The folder to be saved shall be created in advance.

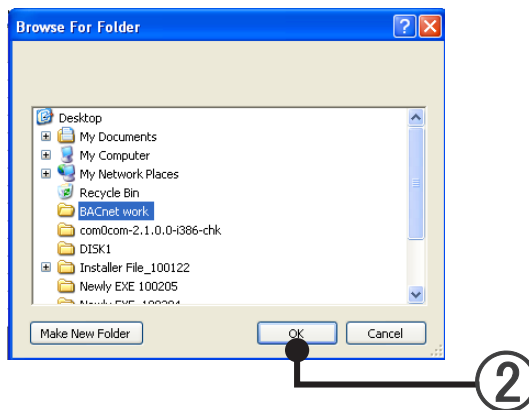

- ③ When “OK” is clicked, the export is complete.

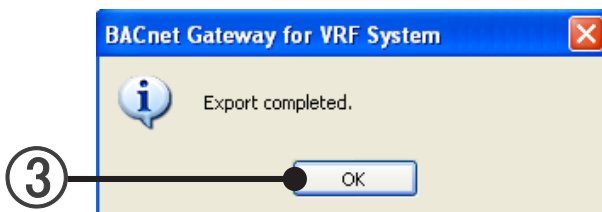

8-4 “View”

1. Description of function

The Indoor unit and Outdoor unit Status information can be viewed.

2. Operating procedure

- ① Select the VRF System (“All” or “Adaptor*”) that you wish to display.

* Menus for only the number of connected adaptors are displayed

Select the menu items in order of “View”→“VRF System”→“All” or “Adaptor*” from the Menu bar

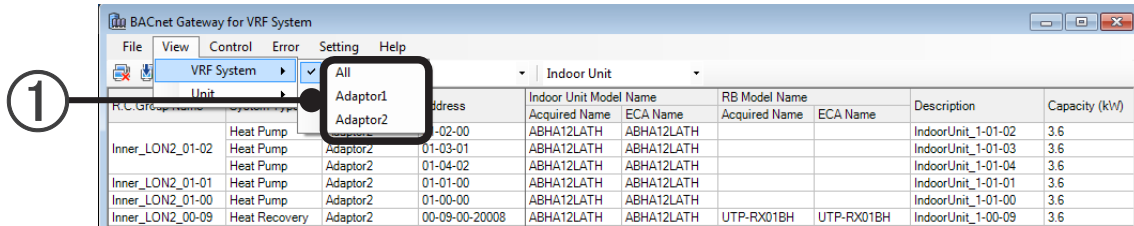

- ② Select the displayed unit (indoor unit or outdoor unit).

Select the menu items in order of “View”→“Unit”→“Indoor Unit” or “Outdoor Unit” from the Menu bar

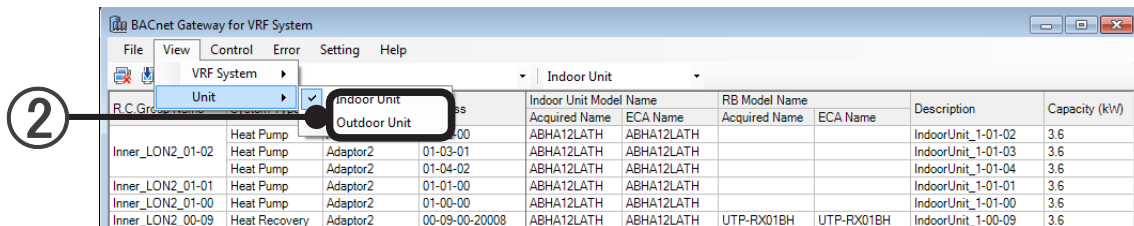

Example) When set to “All” and “Indoor unit”

R.C.Group Name	System Type	Adaptor Name	Address	Indoor Unit Model Name	Acquired Name	ECA Name	RB Model Name	Acquired Name	ECA Name	Description	Capacity (kW)
	Heat Pump	Adaptor2	01-02-00	ABHA12LATH	ABHA12LATH					IndoorUnit_1-01-02	3.6
Inner_LON2_01-02	Heat Pump	Adaptor2	01-03-01	ABHA12LATH	ABHA12LATH					IndoorUnit_1-01-03	3.6
	Heat Pump	Adaptor2	01-04-02	ABHA12LATH	ABHA12LATH					IndoorUnit_1-01-04	3.6
Inner_LON2_01-01	Heat Pump	Adaptor2	01-01-00	ABHA12LATH	ABHA12LATH					IndoorUnit_1-01-01	3.6
Inner_LON2_01-00	Heat Pump	Adaptor2	01-00-00	ABHA12LATH	ABHA12LATH					IndoorUnit_1-01-00	3.6
Inner_LON2_00-09	Heat Recovery	Adaptor2	00-09-00-20008	ABHA12LATH	ABHA12LATH	UTP-RX01BH	UTP-RX01BH			IndoorUnit_1-00-09	3.6

3. Items displayed in the Status List.

I.U.=Indoor unit O.U.=Outdoor unit

Items	Remarks	I.U.	O.U.
“R.C.Group Name”	Remote controller group name	○	-
“Unit Group Name”	Outdoor group name	-	○
“System Type”	Displays the type of refrigerant system (cooling only , heat pump or heat recovery)	○	○
“Adaptor Name”	Connected U10 USB Network Interface adaptor name.	○	○

Items	Remarks	I.U.	O.U.
"Address"	Displays the address for each unit. "Refrigerant system address"- "Unit address"- "R.C. address" or "Refrigerant system address"- "Unit address"- "R.C. address"- "RBG No" For V-II/J-II/VR-II series following notations apply for the address suffix to show how the units are controlled in AUTO mode; /M Master indoor unit /S Slave controlled by master indoor unit /O Externally controlled Those without suffixes are units that not any of the aboves.	○	○
"Indoor Unit Model Name"	Unit model name	○	-
	"Acquired Name"	○	-
	"ECA Name"	○	-
"RB Model Name"	RB model name	-	○
	"Acquired Name"	-	○
	"ECA Name"	-	○
"Outdoor Unit Model Name"	Unit model name	○	-
	"Acquired Name"	○	-
	"ECA Name"	○	-
"Description"	Explanation for Indoor/Outdoor units	○	○
"Capacity"	Capacity of Indoor units	○	
"TYPE"	Indoor unit type *Universal shows Floor or Ceiling.	○	-
"Operation Status"	Operation Status	○	-
	"OP"	○	-
	"MODE"	○	-
	"Set Temp."	○	-
	"Fan Speed"	○	-
"Reliability"	Shows any of the values other than "No_Fault_Detected", of the reliability properties of the objects contained in the unit.	○	○
"Out of service"	Shows "True" if any one of the values of the Out_Of_Service properties of the objects contained in the unit is "True".	○	○
"Error"	State separate from original instruction and operation	○	○
	"Code"	○	○
	"Contents"	○	○
	"Time of Occurrence"	○	○
	"Total Count of Occurrences"	○	○
"Emergency Stop"	Displayed when emergency stop signal sent/received	○	○
"Priority Operation Mode"	Cooling/heating priority operation (Heat pump of S/V Series only)	-	○

8-5 “Control”

8-5-1 “Operation Setting”

1. Description of function

Indoor unit “On/Off”, “Operation Mode”, “temperature setting”, and “Fan speed” can be set.

2. Operating procedure

- ① Select indoor unit.

Select the menu items in order of “View”→“Unit”→“Indoor Unit” from the Menu bar

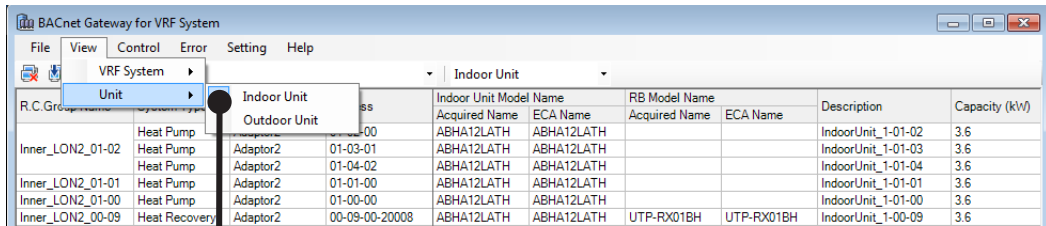

①

- ② Click the unit (line) that you wish to select.

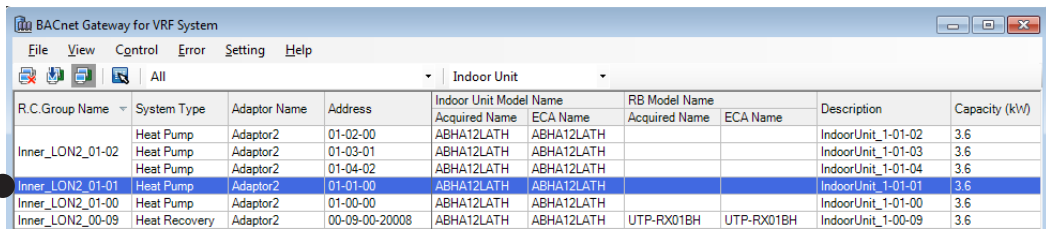

②

- ③ Select the menu items in order of “Control”→“Operation Setting” from the Menu bar

or

Click the **D** button.

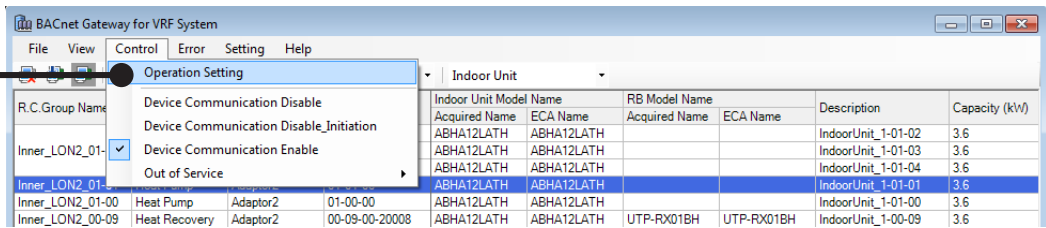

③

D

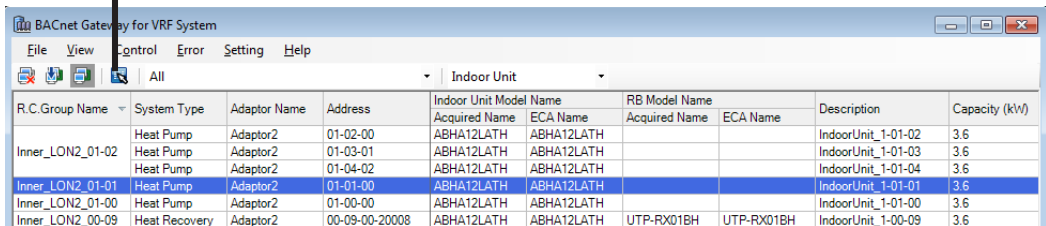

- ④ “Operation Setting” screen is displayed.
When the set button is pressed, “On/Off”, “Operation Mode”, “Set Temp. ”, and ”Fan Speed” can be set.
* Function which cannot be set is not pressed.

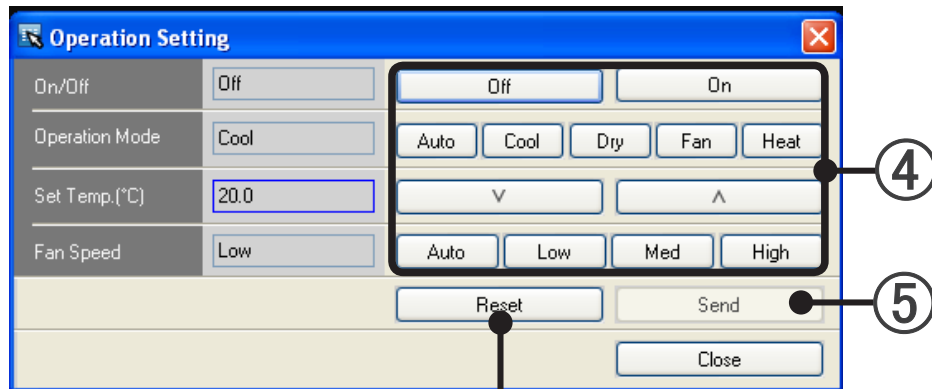

“Reset” button: When this button is pressed, returns to the setting state when this screen was displayed.

Function List

“On / Off”	Switches operation of the selected Indoor Unit On/Off.
“Operation Mode”	Switches Operation Mode to “Auto”, “Cool”, “Dry”, “Fan” or “Heat”.
“Set Temp”	Changes the set temperature.
“Fan Speed”	Switches Fan speed to “Auto”, “Low”, “Med” or “High”.

- ⑤ Click the “Send” button.
Indoor unit setting is switched.

8-5-2 “Device Communication Disable”

1. Description of function

Device communications is disabled.

- * When this setting is performed, communication with the VRF System is not stopped.

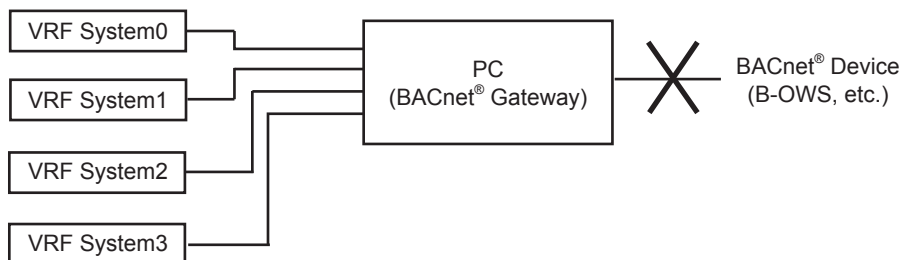

2. Operating procedure

- ① Select the menu items in order of “Control”→“Device Communication Disable” from the Menu bar
or
Click the **A** button.

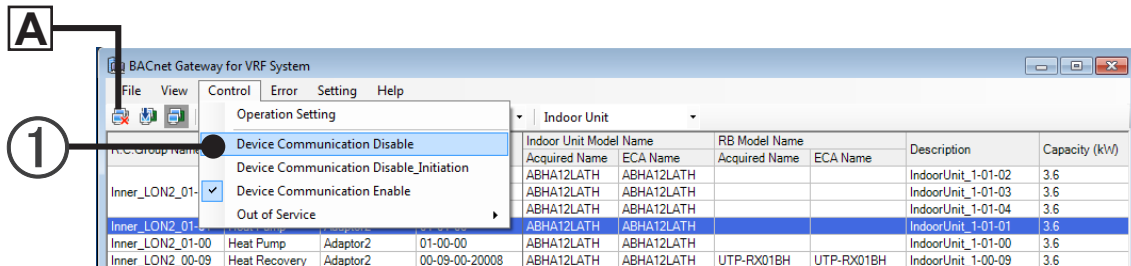

- ② Click the “OK” button on the window of “Disable device communications” shown below.



8-5-3 “Device Communication Disable_Initiation”

1. Description of function

The initiation of communications shall be disabled.

- * When this setting is performed, communication with the VRF System is not stopped.

2. Operating procedure

- ① Select the menu items in order of “Control”→“Device Communication Disable_Initiation” from the Menu bar
or
Click the **B** button.

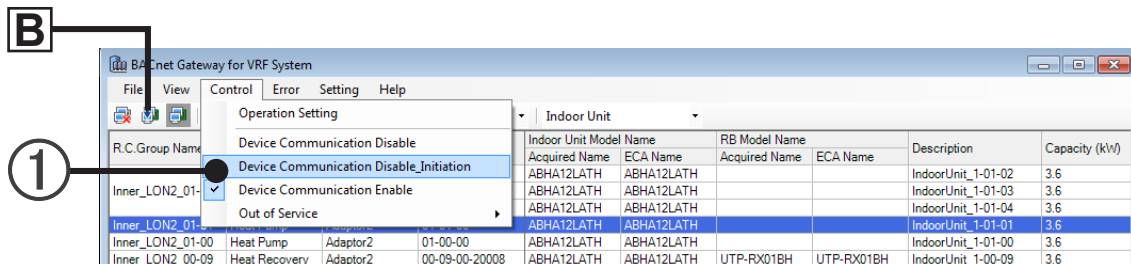

- ② Click the “OK” button on the window of “Disable initiation of communications” shown below.



8-5-4 “Device Communication Enable”

1. Description of function

Communications is enabled.

2. Operating procedure

- ① Select the menu items in order of “Control”→“Device Communication Enable” from the Menu bar
or
Click the **C** button.

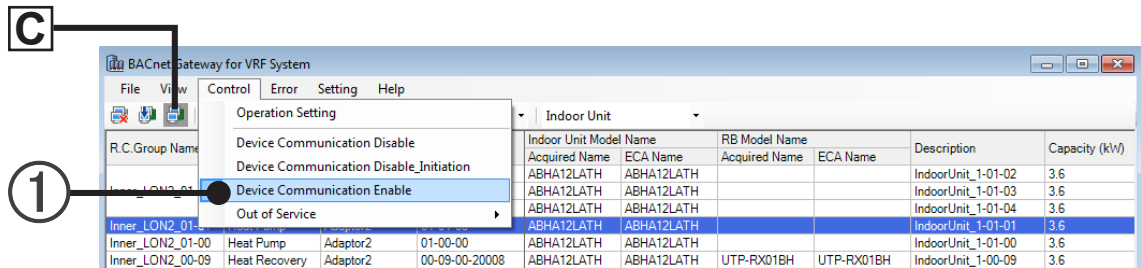

- ② Click the “OK” button on the window of “Enable device communications” shown below.



8-5-5 “Out of Service”

1. Description of function

Set Out_Of_Service properties of all BACnet® objects to “False”.

2. Operating procedure

- ① Select the menu items in order of “Control”→“Out of Service”→“False” from the Menu bar

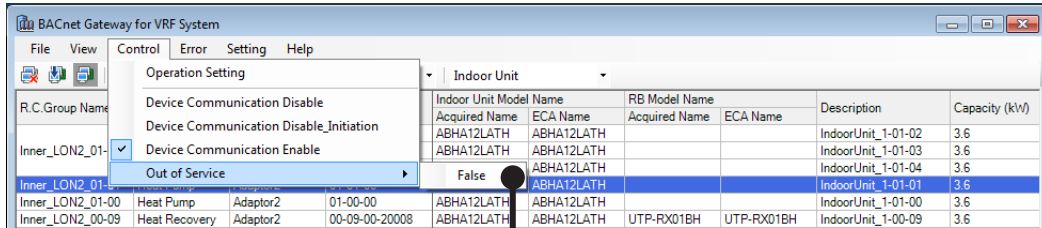

①

- ② Click the “OK” button on the window of “All objects will be put in service.” shown below.

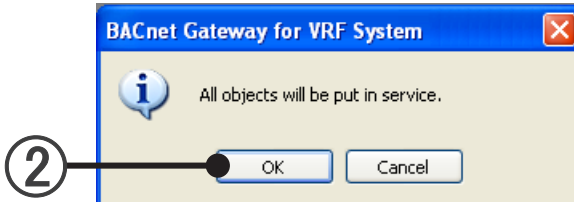

②

8-6 “Error”

“Error information” and “Error History” can be viewed.

8-6-1 Displays “Error Information”

- ① Select the menu items in order of “Error”→“Error Notification” from the Menu bar
or
Automatically opens at error generation.

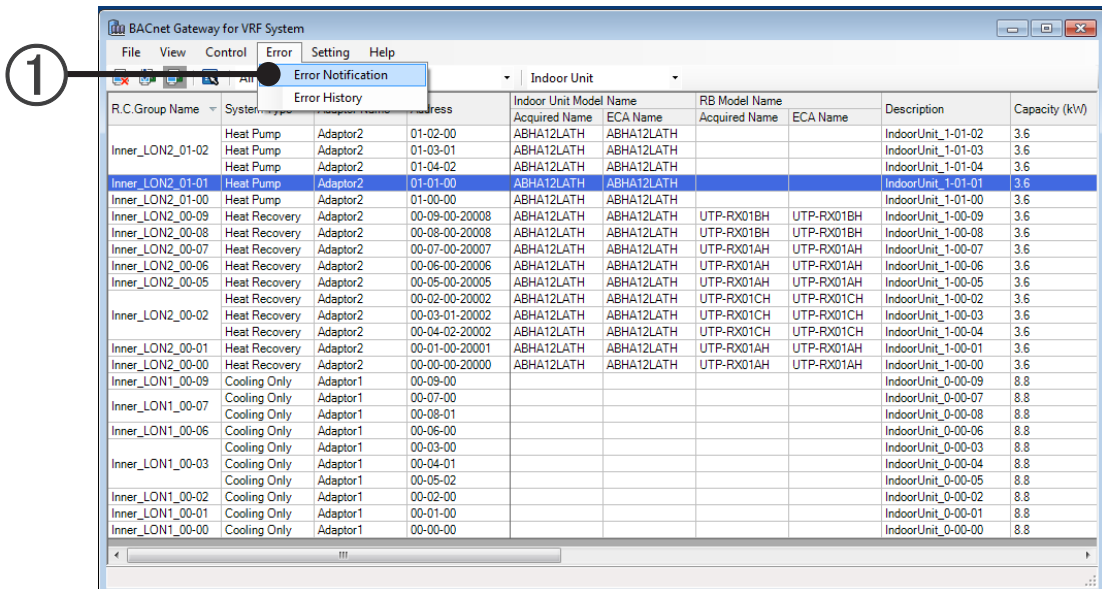

- ② “Error Notification” screen is displayed.

“Error Notification” screen

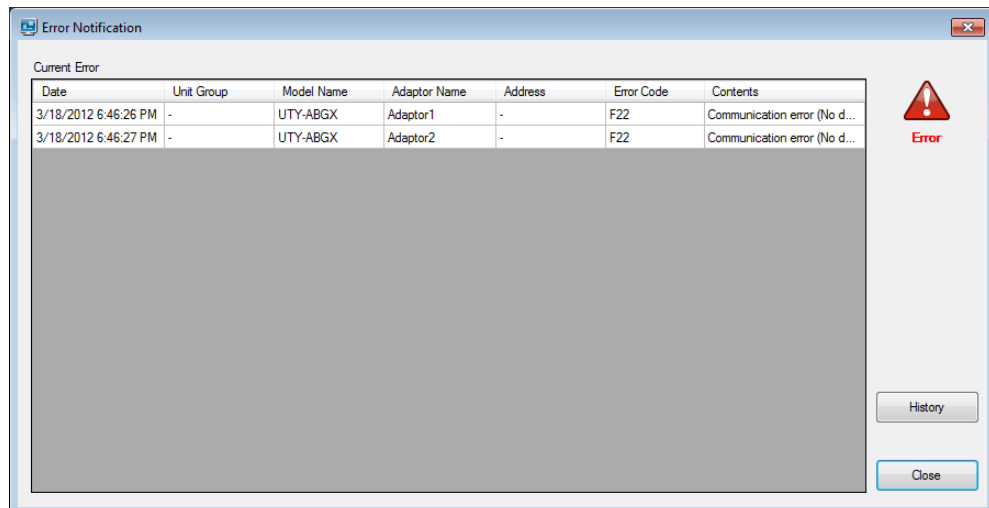

Items displayed in the ERROR List of Indoor/Outdoor Unit.

Items	Remarks
“Date”	Date error occurred
“Unit Group”	When "Indoor Unit" is selected, "R.C.Group Name" is displayed. When "Outdoor Unit" is selected, "Unit Group Name" is displayed. Otherwise, ""-"" is displayed.
“Model Name”	Unit model name* *The letter "-" as the last letter of the Model Name signifies that the Model Name for the corresponding unit was written after shipment. The letter ":" is not part of the Model Name.
“Adaptor Name”	Connected U10 USB Network Interface adaptor name.
“Address”	Displays the address for each unit. Display contents: "Refrigerant system address "-Unit address"-R.C address".
“Error Code”	Error code
“Contents”	Contents

8-6-2 Displays “Error History”

- ① Select the menu items in order of “Error”→“Error History” from the Menu bar
or
Click the “History” button of the “Error Notification” screen.
- ② “Error History” screen is displayed.

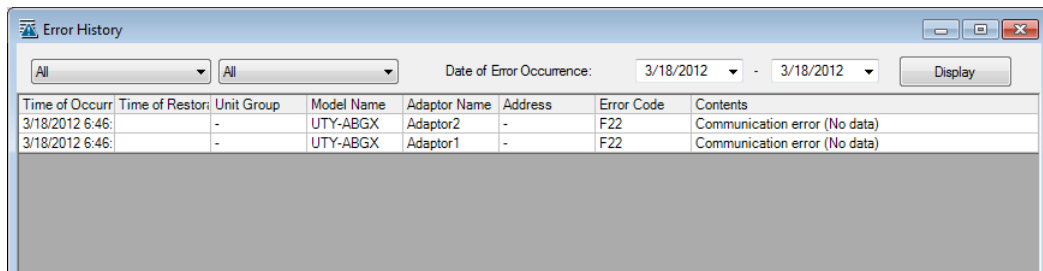

Operation

8-7 “Help”

“Instruction manual”, “Interface Specification Document”, and Version information of BACnet® Gateway is displayed.

8-7-1 Displays “Manual”

- ① Select the menu items in order of “Help”→“Manual” from the Menu bar

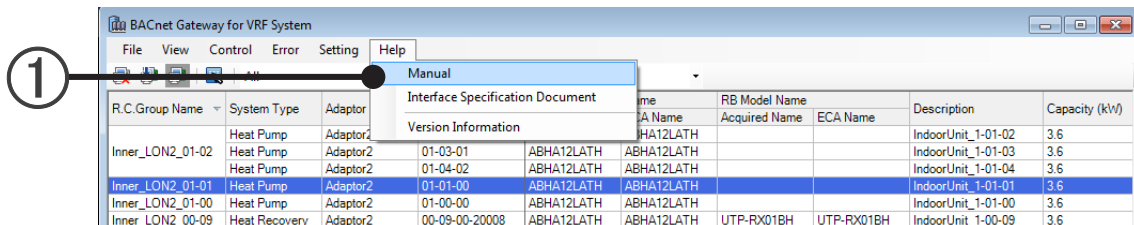

- ② “Instruction manual” (this manual) is displayed.

8-7-2 Displays “Interface Specification Document”

- ① Select the menu items in order of “Help”→“Interface Specification Document” from the Menu bar
- ② “Interface Specification Document” is displayed.

8-7-3 Displays Application “Version Information”

- ① Select the menu items in order of “Help”→“Version Information” from the Menu bar
- ② “Version Information” is displayed.

Appendix

- 9. Product Specifications
- 10. Error Code Table
- 11. FAQ

9. Product Specifications

9-1 Operating Conditions

PERSONAL COMPUTER SPECIFICATIONS

Operating system	•Microsoft® Windows® XP SP3 (32-bit) Professional •Microsoft® Windows® Vista® SP2 (32-bit) Home Premium, Business •Microsoft® Windows® 7 SP1 (32/64-bit) Home Premium, Professional [Supported languages] English, Chinese, French, German, Russian, Spanish, and Polish
CPU	Intel® Core™ i3 2GHz or higher
Memory	2GB or more (Windows® XP, Vista®, 7 32-bit) 4GB or more (Windows® 7 64-bit)
HDD	40GB or more of free space
Display	1024 x 768 or higher resolution
Interface	USB port (x2-5) is required Ethernet port is required
Software required	Adobe® Reader® 9.0 or later
Hardware required	DVD-ROM Drive

9-2 Accessories

DVD-ROM (Application and Manual).....	(1)
USB Software Protection key	(1)

10. Error Code Table

The BACnet® Gateway error codes are shown below. When an error occurred at the BACnet® Gateway, check the codes below and contact your service personnel.

Refer to the Interface Specification document for the Indoor unit and Outdoor unit error codes.

Error code	Error contents
F11	Database access error
F12	Database connection error
F13	Software restart error
F14	Program run time error
F15	Error at execution of various special operations
F16	Insufficient vacant space on HDD used by database
F21	Transmission adaptor connection failed
F22	Transmission error (data not acquired)
F23	External input power meter error
F31	Communication between processes error
F32	Software protection key not recognized (including fault WIBU-KEY obstruction)
F33	Server/client communication error
F41	HDD capacity error
F42	System requirements error
F43	Time error

11. FAQ

11-1 General

No.	Question
	Answer
1.	The PC power was dropped during unit scanning. What happens to the data scanned up to the point? Is data integrity maintained?
	The scanned data is saved when scanning is completed and the "OK" button is pressed. When the power was dropped before this, the data scanned up to that point is lost. Restart scanning from the beginning. → 6-6 "Unit Registration".
2.	When scanning, U10 USB Network Interface is not displayed as a selection choice. What should I do?
	U10 USB Network Interface driver is not installed. Install the OpenLDV supplied with the U10. Power is not supplied. If an USB hub is used or many USB units are connected, the power supply may be insufficient. Connect the USB units directly to the PC, or reduce the number of USB units connected.
3.	Can the U10 USB Network Interface used with the BACnet® Gateway also be used with service tools and other software?
	The adaptor can also be used with service tools. However, 1 adaptor cannot be used simultaneously by the BACnet® Gateway and service tools.
4.	What is the difference between Secure Reg enable and disable at "Unit Registration"?
	Secure Reg. is a mode which stops operation of all the units and confirms scanning for "Unit Registration". Secure Reg. disable is a mode which performs scanning in parallel without stopping operation of the units. Since scanning is an important function for recognition of the units to be managed by the BACnet® Gateway, it is recommended that, as a rule, it be performed by enabling Secure Reg. If unavoidable, disable Secure Reg only when scanning must be performed without stopping operation of the units. In any case, whether or not units were recognized correctly must be confirmed after scanning. However, when scanning was performed with Secure Reg disabled, re-scanning may be necessary due to "Unit Registration" failures.
5.	Scanning was performed, but all the units were not recognized. What should I do?
	When work is performed normally and scanning is performed after confirmation and units are not recognized, first check that the power of the unrecognized units is turned on. Other causes may be: •Unit trouble •Installation work problem Contact your service personnel.
6.	Scanning was performed, and all the units were recognized, but R.C. group information is not correct. What should I do?
	They may be an abnormality in the wiring which defines the R.C. group or incorrect setting of the address in the indoor unit R.C. group. Refer to the service manual and perform setting correctly.
7.	Scanning was performed and all the units were recognized, but the unit information is not correct. What should I do?
	It is possible that communication with the unit is incomplete. Enter a secure reg. check mark and re-scan. → 6-6 "Unit Registration".
8.	Scanning takes a very long time. What can I do?
	When the existing refrigerant system numbers are known in advance, the scanning time may be shortened by specifying the refrigerant range to be scanned at the scan execution screen. For example, when rescanning, etc. when recognition by scanning isn't very good, the scanning time can be shortened by specifying the range of only the refrigerant systems at which recognition was poor. In addition, scanning by "secure reg." is faster than scanning "without secure reg.". → 6-6 "Unit Registration".

No.	Question
	Answer
9.	I want to replace the PC with a new PC. Can the data be transferred?
	The BACnet® Gateway has data “Export” and “Import” functions. For details, see the “Import/Export” page.
10.	Unit expansion, replacement, and removal were performed. How can I reflect these changes at the BACnet® Gateway?
	Perform scanning again. → 6-6 “Unit Registration”.
11.	VRF System expansion, replacement, and removal were performed.
	After setting the U10 USB Network Interface adaptor correctly, recognize the units by scanning. → 6-4 “Initial Setting” , 6-5 “Adaptor Setting” , 6-6 “Unit Registration”
12.	The state displayed on the screen does not change even though operation setting is performed.
	When operation setting was performed at multiple units or at a group containing multiple units, it may take some time for the state of that unit to change to the set contents.
13.	Can a transmission adaptor (UTR-YTMA) be used with the BACnet® Gateway?
	Transmission adaptor (UTR-YTMA) cannot be used with the BACnet® Gateway.
14.	Can a WIBU-KEY used by a UTR-YLBA be used by the BACnet® Gateway?
	Since the UTR-YLBA and BACnet® Gateway are separate products, the WIBU-KEY used by the UTR-YLBA cannot be used by the BACnet® Gateway.
15.	Can a XLON® used by a UTR-YLBA be used by the BACnet® Gateway?
	No. it cannot be used.
16.	When an error, etc. occurs at SQL Server 2008 R2 installation while this application is installed
	For the identification of reason and the countermeasures, check the contents of log file in the following folder. C:\Program Files\Microsoft SQL Server\100\Setup Bootstrap\Log
17.	Why is an electricity charge generated even though none of the indoor units is being used?
	Since power is consumed by the outdoor unit even when all the indoor units are not in use, an electricity charge is generated. To prevent generation of an electricity charge, turn off the power of that indoor unit and perform scan to remove the indoor unit from the electricity charge apportionment function objectives.
18.	Why isn't the operation time and electricity charge proportional?
	If the room temperature has reached the set temperature even if the operation is turned ON by a remote controller, the indoor unit will not operate and the power consumption will be that much lower. In addition, if the difference between the room temperature and the set temperature is large, more power is consumed than when the difference is small. Therefore, the operation time and electricity charge may not necessarily be proportional.
19.	Why is the electricity charge of operated indoor units so much smaller than that of indoor units that are not operated at all?
	Electricity charge includes the power consumed by the outdoor unit in addition to that of the indoor unit. The outdoor unit consumes power constantly so that operation at any time is possible even though indoor units are not operating. This is called the “standby power”. Since the standby power differs between the models of outdoor units, if the number of indoor units per outdoor unit is assumed to be the same, the indoor units which use an outdoor unit will consume more power than indoor units which use with high standby power. This question is an example of when the difference of this standby power was larger than the power consumed by operation. This is a normal result. Generally, this kind of difference is made small by selecting the model of outdoor unit based on appropriate facility design.

No.	Question
	Answer
20.	Why has the electricity charge suddenly increased even though the use is the same as in the past?
	One of the reason could be that some tenants have moved out. The electricity charge is apportioned between blocks. When the number of blocks decreases or increases by moving in and out of tenants, the electricity charge increases and decreases. As an example, if the basic charge is set so that it is equally apportioned between the blocks, then the electricity charges decreases if tenants move in and increases if tenants move out. The building owners and managers should perform appropriate settings in accordance with his/her policy as to how things should be in such cases.
21.	Characters displayed on the screen are strange. What should I do?
	Region is not set. Refer to 5-3 "Regional Setting" and set the region. OS or PC trouble Contact the manufacturer of your PC.

11-2 Trouble Shooting BACnet® Installation

Trouble Shooting Procedures

If you can not perform monitorings and controls of VRF system form B-OWS, the first step for the trouble shooting is to localize the trouble.

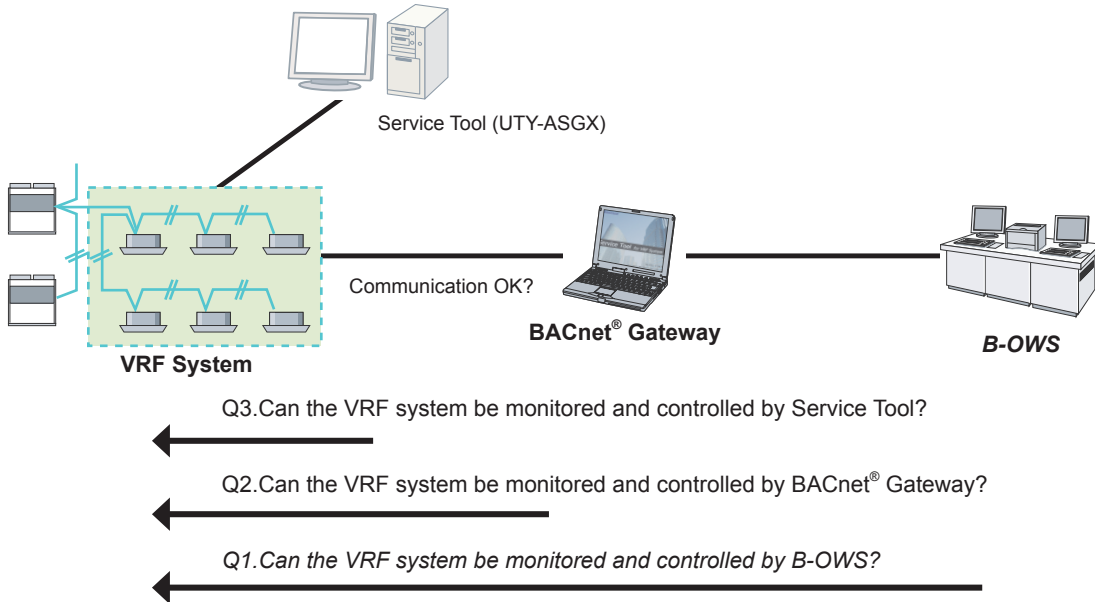

B-OWS : Operator Workstation, workstation used in the building management system.

Answer each questions in the diagram to see what sort of troubles are suspected.

Q1. Can the VRF system be monitored and controlled by B-OWS?

If no, any of the troubles below is suspected;

- S1) VRF system is faulty or is not setup properly.
- S2) Communication between BACnet® Gateway and VRF system is not normal.
- S3) BACnet® Gateway is faulty or is not setup properly.
- S4) Communication between the B-OWS and BACnet® Gateway is not normal.
- S5) B-OWS is faulty or is not setup properly.

Q2. Can the VRF system be monitored and controlled by BACnet® Gateway?

If no, any of the troubles below is suspected;

- S1) VRF system is faulty or is not setup properly.
- S2) Communication between BACnet® Gateway and VRF system is not normal.
- S3) BACnet® Gateway is faulty or is not setup properly.

Q3. Can the VRF system be monitored and controlled by Service Tool?

If no, the trouble below is suspected;

- S1) VRF system is faulty or is not setup properly.

For each of the troubles suspected, perform the following checks to identify the problem.

S1. VRF system is faulty or is not setup properly.

If the VRF system itself is not working properly, consult the the Service Manuals for VRF system.

S2. Communication between BACnet® Gateway and VRF system is not normal.

If the communication within the VRF system is not working properly, consult the Service Manuals for VRF system.

S3.BACnet® Gateway is faulty or is not setup properly.

Refer to the Instruction Manual (this manual) of BACnet® Gateway.

See also A1.Initial setting for PC.

S4.Communication between the B-OWS and BACnet® Gateway is not normal.

See A2.Networking Troubles.

S5.B-OWS is faulty or is not setup properly.

Refer to the manual that comes with the B-OWS.

Be sure that settings are correct for connecting with the BACnet® Gateway.

A1:Initial Setting for PC

(1) Network Setting for the PC

Perform appropriate setting for the transparent connection of UDP/IP unicast and multicast communication.

- IP Address / Netmask Setting
- UDP port 0xBAC0(47808) made available and enabled
When checking whether the UDP port is already in use, execute a “netstat -a” command from the Windows Command Prompt. At that time, end BACnet® Gateway before executing the command.
If the UDP port should be in use, stop using the relevant application.

A2:Networking Troubles

(1) Checking Unicast Communication

Ping to/from BACnet® Gateway – B-OWS using Windows Command Prompt.

Ex. “Ping 192.168.16.2”

If you get the response, unicast is reachable.

(2) Checking Broadcast Communication

Trace route to/from BACnet® Gateway – B-OWS using Windows Command Prompt.

Ex. “Tracert 192.168.16.2”

Trouble Shooting the Interworking Troubles

BACnet® is an open network protocol interpreted and implemented by different vendors.

In some occasions, you may encounter interworking troubles.

If the trouble could not be located in the procedures above, interworking troubles may be suspected.

Analyzing interworking troubles involve capturing BACnet® communication packets and analyzing the protocol using tools (ex.Wireshark) and expertise on BACnet®.

Followings are some hints on the checks you need to perform in order to trouble shoot interworking problems.

1. Has B-OWS recognized BACnet® Gateway?
If the B-OWS does not recognize BACnet® Gateway, then the initial setting may be wrong or networking problem is suspected.
2. Has B-OWS established connection to the BACnet® Gateway?
If the B-OWS cannot establish connection with BACnet® Gateway (eg.B-OWS has issued error after series of communication), then packets must be captured to see where and what has gone wrong.
3. Has B-OWS registered units in VRF System correctly?
If the B-OWS cannot register units in VRF System correctly, then registration must be checked first using BACnet® Gateway user interface. If there are no problems on the BACnet® Gateway, then packets must be captured to see where and what has gone wrong.
4. What Service is Malfunctioning?
If any service cannot be performed on the B-OWS, then packets must be captured to see where and what has gone wrong.