

INSTRUCTION MANUAL

•INSTALLATION •SETTING •OPERATING

System Controller for VRF System

UTY-APGX

Ver. 2.3



PART NO. 9708870007-5

FUJITSU GENERAL LIMITED

LICENSE AGREEMENT

For

“SYSTEM CONTROLLER for VRF SYSTEM”

IMPORTANT-READ CAREFULLY

This “SYSTEM CONTROLLER for VRF SYSTEM” License Agreement (LICENSE AGREEMENT) is a legal agreement between you and Fujitsu General Limited (FGL) for the use of VRF SYSTEM CONTROLLER (“VRF CONTROLLER (for server computer) / VRF EXPLORER (for client computer)”) products designated below, which includes computer software and printed materials, and may include online or electronic documentation (collectively “SOFTWARE PRODUCT” or “SOFTWARE”). By installing, copying, or otherwise using the SOFTWARE PRODUCT, you accept to be bound by all of the terms and conditions of this LICENSE AGREEMENT. If you do not agree to any of the terms and conditions of this LICENSE AGREEMENT, you may not use the SOFTWARE PRODUCT and shall promptly return the SOFTWARE PRODUCT to the place where you have obtained it.

1. COPYRIGHT AND OWNER SHIP.

The SOFTWARE PRODUCT is protected by copyright laws and international copyright treaties, as well as other intellectual property laws and treaties. The SOFTWARE PRODUCT is licensed to you, not sold. FGL owns the title, copyright, and other intellectual property rights in the SOFTWARE PRODUCT.

2. GRANT OF LICENSE.

FGL hereby grants you the limited, non-exclusive and non-transferable rights to use the SOFTWARE PRODUCT only for the purpose of controlling the VRF air-conditioning system products (VRF) provided you comply with all terms and conditions of this LICENSE AGREEMENT. You may copy the SOFTWARE PRODUCT solely for backup or archival purposes.

3. DESCRIPTION OF OTHER RIGHTS AND LIMITATIONS.

(1) LIMITATIONS ON REVERSE ENGINEERING, DECOMPILATION, AND DISASSEMBLY.

You may not modify, alter, reverse engineer, decompile, or disassemble the SOFTWARE PRODUCT, you shall not alter or remove any copyright, trademark or other proprietary notice of FGL from the SOFTWARE PRODUCT.

(2) RENTAL.

You may not rent or lease the SOFTWARE PRODUCT.

(3) SOFTWARE TRANSFER

You may not transfer the SOFTWARE PRODUCT to any person and/or entity (-ies) either payable or free of charge.

(4) TERMINATION

Without prejudice to any other rights, FGL may terminate this LICENSE AGREEMENT if you fail to comply with the terms and conditions of this LICENSE AGREEMENT. In such an event, you shall promptly return all originals and copies of the SOFTWARE PRODUCT to FGL.

4. INSTALLATION AND USE OF SOFTWARE PRODUCT.

(1) VRF CONTROLLER (for server computer)

You may install and use VRF CONTROLLER on a single computer (“server computer”) under one of the operating environment identified in the documentation accompanying the SOFTWARE.

The server computer necessary to use VRF CONTROLLER (PC, accessories, etc.), shall be prepared separately by you.

(2) VRF EXPLORER (for client computer)

You may install and use VRF EXPLORER on any of your computers (“client computers”) under one of the operating environment identified in the documentation accompanying the SOFTWARE.

You may not network VRF EXPLORER or otherwise use it in excess of 5 client computers at the same time.

The client computers necessary to use VRF EXPLORER (PC, accessories, etc.), shall be prepared separately by you.

5. NO WARRANTY.

FGL EXPRESSLY DISCLAIMS ANY WARRANTY FOR THE SOFTWARE PRODUCT AND ANY RELATED DOCUMENTATION. THE SOFTWARE PRODUCT AND ANY RELATED DOCUMENTATION ARE PROVIDED "AS IS" WITHOUT WARRANTY OF ANY KIND, EITHER EXPRESSED OR IMPLIED, INCLUDING, WITHOUT LIMITATION, STATUTORY WARRANTIES, THE IMPLIED WARRANTIES MERCHANTABILITY OF FITNESS FOR A PARTICULAR PURPOSE OR NON-INFRINGEMENT OF THIRD PARTY'S RIGHTS. THE ENTIRE RISK ARISING OUT OF USE OR PERFORMANCE OF THE SOFTWARE PRODUCT REMAINS WITH YOU. HOWEVER, IF WITHIN (90) DAYS FOLLOWING YOUR PURCHASE OF THE SOFTWARE, YOU NOTIFY FGL OF PHYSICAL DEFECT OF THE MEDIA CONTAINING SOFTWARE, FGL WILL REPLACE THE DEFECTIVE MEDIA WITH NEW MEDIA.

6. LIMITATION OF LIABILITY.

IN NO EVENT SHALL FGL BE LIABLE FOR ANY DAMAGES WHATSOEVER (INCLUDING, WITHOUT LIMITATION, DAMAGES FOR LOSS OF BUSINESS PROFIT, BUSINESS INTERRUPTION OR LOSS OF BUSINESS INFORMATION, DAMAGES ARISING OUT OF DATA OR INFORMATION DERIVED FROM OR BASED ON THE ELECTRICITY CHARGE APPORTIONMENT FUNCTION IN THE SOFTWARE OR ANY OTHER PECUNIARY LOSS) DIRECT OR INDIRECT, TO YOU OR TO ANY THIRD PARTY, ARISING OUT OF THE USE OR INABILITY TO USE THE SOFTWARE, EVEN IF FGL HAS BEEN ADVISED OF THE POSSIBILITY OF SUCH DAMAGES.

7. ENTIRE AGREEMENT.

This LICENSE AGREEMENT (including any addendum or amendment to this LICENSE AGREEMENT included with the SOFTWARE PRODUCT) is the entire agreement between you and FGL relating to the SOFTWARE PRODUCT and supersedes all prior contemporaneous oral or written communications, proposals and representations with respect to the SOFTWARE PRODUCT or any other subject covered by this LICENSE AGREEMENT.

8. INDEMNITY.

You agree to indemnify and hold FGL, and its subsidiaries, affiliates, officers, agents, co-branders or other partners, and employees, harmless from any damage, claim or demand, including without limitation reasonable attorneys' fees, made by any third party due to or arising out of use of the SOFTWARE.

9. GOVERNING LAW AND JURISDICTION.

This LICENSE AGREEMENT is governed by the laws of JAPAN. You and FGL hereby irrevocably submit to the exclusive jurisdiction of the Tokyo District Court and other higher courts having jurisdiction in Japan for the settlement of disputes arising under or in connection with this LICENSE AGREEMENT.

LICENSE AGREEMENT
For
“SYSTEM CONTROLLER for VRF SYSTEM”

Other License Agreements

This product includes encryption program written by Eric Young (eay@cryptsoft.com).

Copyright (C) 1995-1998 Eric Young (eay@cryptsoft.com)

All rights reserved.

This package is an SSL implementation written by Eric Young (eay@cryptsoft.com).

The implementation was written so as to conform with Netscapes SSL.

This library is free for commercial and non-commercial use as long as the following conditions are adhered to.

The following conditions apply to all code found in this distribution, be it the RC4, RSA, lhash, DES, etc., code; not just the SSL code.

The SSL documentation included with this distribution is covered by the same copyright terms except that the holder is Tim Hudson (tjh@cryptsoft.com).

Copyright remains Eric Young's, and as such any Copyright notices in the code are not to be removed.

If this package is used in a product, Eric Young should be given attribution as the author of the parts of the library used.

This can be in the form of a textual message at program startup or in documentation (online or textual) provided with the package.

Redistribution and use in source and binary forms, with or without modification, are permitted provided that the following conditions are met:

1. Redistributions of source code must retain the copyright notice, this list of conditions and the following disclaimer.

2. Redistributions in binary form must reproduce the above copyright notice, this list of conditions and the following disclaimer in the documentation and/or other materials provided with the distribution.

3. All advertising materials mentioning features or use of this software must display the following acknowledgement:

"This product includes cryptographic software written by Eric Young (eay@cryptsoft.com)"

The word 'cryptographic' can be left out if the routines from the library being used are not cryptographic related :-).

4. If you include any Windows specific code (or a derivative thereof) from the apps directory (application code) you must include an acknowledgement:

"This product includes software written by Tim Hudson (tjh@cryptsoft.com)"

THIS SOFTWARE IS PROVIDED BY ERIC YOUNG "AS IS" AND ANY EXPRESS OR IMPLIED WARRANTIES, INCLUDING, BUT NOT LIMITED TO, THE IMPLIED WARRANTIES OF MERCHANTABILITY AND FITNESS FOR A PARTICULAR PURPOSE ARE DISCLAIMED. IN NO EVENT SHALL THE AUTHOR OR CONTRIBUTORS BE LIABLE FOR ANY DIRECT, INDIRECT, INCIDENTAL, SPECIAL, EXEMPLARY, OR CONSEQUENTIAL DAMAGES (INCLUDING, BUT NOT LIMITED TO, PROCUREMENT OF SUBSTITUTE GOODS OR SERVICES; LOSS OF USE, DATA, OR PROFITS; OR BUSINESS INTERRUPTION)

HOWEVER CAUSED AND ON ANY THEORY OF LIABILITY, WHETHER IN CONTRACT, STRICT LIABILITY, OR TORT (INCLUDING NEGLIGENCE OR OTHERWISE) ARISING IN ANY WAY OUT OF THE USE OF THIS SOFTWARE, EVEN IF ADVISED OF THE POSSIBILITY OF SUCH DAMAGE.

This product includes software developed by OpenSSL Project(<http://www.openssl.org/>) to be used for OpenSSL toolkit.

Copyright (c) 1998-2008 The OpenSSL Project. All rights reserved.

Redistribution and use in source and binary forms, with or without modification, are permitted provided that the following conditions are met:

1. Redistributions of source code must retain the above copyright notice, this list of conditions and the following disclaimer.

2. Redistributions in binary form must reproduce the above copyright notice, this list of conditions and the following disclaimer in the documentation and/or other materials provided with the distribution.

3. All advertising materials mentioning features or use of this software must display the following acknowledgment:

"This product includes software developed by the OpenSSL Project for use in the OpenSSL Toolkit. (<http://www.openssl.org/>)"

4. The names "OpenSSL Toolkit" and "OpenSSL Project" must not be used to endorse or promote products derived from this software without prior written permission. For written permission, please contact openssl-core@openssl.org.

5. Products derived from this software may not be called "OpenSSL" nor may "OpenSSL" appear in their names without prior written permission of the OpenSSL Project.

6. Redistributions of any form whatsoever must retain the following acknowledgment:

"This product includes software developed by the OpenSSL Project for use in the OpenSSL Toolkit (<http://www.openssl.org/>)"

THIS SOFTWARE IS PROVIDED BY THE OpenSSL PROJECT "AS IS" AND ANY EXPRESSED OR IMPLIED WARRANTIES, INCLUDING, BUT NOT LIMITED TO, THE IMPLIED WARRANTIES OF MERCHANTABILITY AND FITNESS FOR A PARTICULAR PURPOSE ARE DISCLAIMED. IN NO EVENT SHALL THE OpenSSL PROJECT OR ITS CONTRIBUTORS BE LIABLE FOR ANY DIRECT, INDIRECT, INCIDENTAL, SPECIAL, EXEMPLARY, OR CONSEQUENTIAL DAMAGES (INCLUDING, BUT NOT LIMITED TO, PROCUREMENT OF SUBSTITUTE GOODS OR SERVICES; LOSS OF USE, DATA, OR PROFITS; OR BUSINESS INTERRUPTION) HOWEVER CAUSED AND ON ANY THEORY OF LIABILITY, WHETHER IN CONTRACT, STRICT LIABILITY, OR TORT (INCLUDING NEGLIGENCE OR OTHERWISE) ARISING IN ANY WAY OUT OF THE USE OF THIS SOFTWARE, EVEN IF ADVISED OF THE POSSIBILITY OF SUCH DAMAGE.

Contents

1. Usage Precautions	11
1-1 Precautions when using the System Controller	11
2. How To Use This Manual	12
2-1 Manual composition	12

Introduction

3. Overview	14
3-1 Features	14
3-2 System Controller composition	15
3-3 Example of use	17
3-4 Function list	19
4. Materials To Be Prepared Beforehand	21

Server PC Installation

5. Installation (Server PC)	24
5-1 Installation flow	25
5-2 Hardware installation (transmission adaptor)	26
5-2-1 Transmission adaptor installation	26
5-2-2 Wiring and turning on the units power	28
5-3 Software installation (applications, drivers)	29
5-3-1 Installation notes	29
5-3-2 Software install	30
5-3-3 Installation completion and initial starting	33
5-4 Uninstall and version upgrade	35
5-4-1 System Controller uninstall	36
5-4-2 WIBU-KEY driver uninstallation	37
5-4-3 Microsoft® SQL Server® uninstallation	38
5-4-4 Microsoft® SQL Server® Native Client uninstallation	43

Client PC Installation

Client PC Installation	45
6. Network Setting	46
6-1 Network setting (server PC side setting)	48
6-1-1 Incoming setting (for dial-up connection)	49
6-2 Network setting (client PC side setting)	55
6-2-1 LAN connection setting	56
6-2-2 Dial-up connection setting	60

7. Installation (Client PC)	64
7-1 Installation flow	64
7-1-1 Software install	65
7-1-2 Initial starting	68
7-1-3 Object site setting	69
7-1-4 Master data acquisition	71
7-2 Uninstall and version upgrade	72
7-2-1 System Controller uninstall	73

Settings

8. Basic Settings	76
8-1 User management settings	80
8-1-1 User Setting screen	80
8-1-2 New user registration	82
8-1-3 Registered user editing	83
8-2 System Time Settings	84
8-2-1 System Time Setting screen	84
8-3 Initial setting	86
8-3-1 Site name setting	87
8-3-2 Transmission adaptor setting	88
8-3-3 Unit registration	89
8-3-4 Unit name registration	92
8-3-5 Layout editing	95
8-3-5-1 Layout Edit screen	95
8-3-5-2 Site editing	98
8-3-5-3 Building editing	101
8-3-5-4 Unit arrangement	103
8-3-5-5 Floor editing	105
8-3-6 Group setting	109
9. Electricity Charge Apportionment Setting	115
9-1 Overview	116
9-2 Electricity charge apportionment main screen	121
9-2-1 Main screen	122
9-3 Basic Setting	124
9-4 Indoor unit electricity calculation setting	125
9-5 Parameter setting	127
9-6 Contract setting	130
9-6-1 Contract list creation	131
9-6-2 New contract creation and editing	132
9-7 Block setting	134
9-7-1 Block schedule setting	134
9-7-2 Specify Block screen	136
9-7-3 Common block setting	140

10. Error E-mail Notification Setting	141
10-1 E-mail Setting screen	141
10-2 Out going mail server setting	142
11. User Environment Setting	143
11-1 Environment Setting screen	144
11-1-1 Alarm sound setting	144
11-1-2 Temperature units setting	145
11-1-3 Screen size setting	145

VRF Controller Operation

12. Starting And Ending The VRF Controller	147
12-1 VRF Controller starting method	147
12-2 Ending the VRF Controller	149
13. Task Tray Operation	150
13-1 VRF Explorer starting	150
13-2 Security setting	151
13-3 Port Setting	152
13-4 Data import/export	153
13-4-1 All data	153
13-4-2 Only the registration and layout data	157
13-5 Version	160
13-6 End	161

VRF Explorer Operation

Standard Operation Case	163
14. Overview Of VRF Explorer	164
14-1 Composition of VRF Explorer	164
14-1-1 Screens making up VRF Explorer	164
14-1-2 Screen transition	166
15. Starting And Ending The VRF Explorer	167
15-1 Starting the VRF Explorer	167
15-2 Ending the VRF Explorer	168
16. Site Navigator	169
16-1 Site Navigator	171
16-1-1 Site Navigator	171
16-1-2 Communication connection to site	173
16-1-3 Disconnection of communication to site	174
16-1-4 Site details display	175
16-2 Site setting	176
17. Basic Operation	178
17-1 VRF Explorer screen composition	178
17-1-1 Composition of main screen	178

17-1-2	Function screens	184
17-2	Overview of monitor screens	185
17-2-1	Monitor screens	186
17-3	Layout display	189
17-3-1	Monitoring in the site display mode	189
17-3-2	Monitoring in the building 3D display mode	191
17-3-3	Monitoring in the floor display mode	195
17-4	List display	198
17-5	Tree display	202
17-6	Associated operation	204
17-7	Display Option setting	208
18. Operation Control		209
18-1	Quick operation	209
18-2	Detail operation	212
18-2-1	Basic operation	212
18-2-2	Extended operation	217
18-3	Memory operation	219
18-3-1	Load operation pattern	219
18-3-2	Save operation pattern	220
19. Schedule Operation		221
19-1	Schedule Setting screen	221
19-2	Overview (flow) of schedule operation creation	224
19-3	Operation pattern creation	225
19-3-1	Pattern Setting screen	225
19-3-2	Overview of operation pattern creation	226
19-3-3	Operation pattern setting items	228
19-4	Pattern assignment to calendar	231
19-4-1	Selection of schedule operation target	231
19-4-2	Assigning operation pattern to calendar (daily)	232
19-4-3	Assigning operation pattern to calendar (every day of week)	233
19-4-4	Assigning the OFF day on the calendar	234
19-4-5	Calendar updating	236
19-5	Period Setting	237
19-6	Exceptional day (holiday, etc.) setting	238
19-6-1	Exceptional Day Setting screen	238
19-6-2	Overview of exceptional day creation	239
20. Error Monitoring		241
20-1	Overview of error notification	241
20-2	Status display	241
20-3	Error Notification screen	242
20-4	Identifying the location of unit that generated the error	243
20-5	Unit error history	244
20-5-1	Error History screen display method	244
20-5-2	Error History screen	245
20-5-3	History display method	246
20-5-4	Writing of history	247

20-5-5	Sorting history display	247
21.	Operation Management	248
21-1	Operation history	248
21-1-1	Operation History screen	248
21-1-2	History display method	251
21-1-3	Writing of history	252
21-1-4	History display sorting	252
22.	Electricity Charge Apportionment	253
22-1	Electricity charge apportionment main screen	253
22-1-1	Electricity Charge Apportionment main screen	254
22-2	Apportionment calculation execution	255
22-2-1	Apportionment Calculation screen	255
22-2-2	Calculation result screen	257
22-2-3	Calculation history	259
22-3	Bill creation	261
22-3-1	Bill setting	261
22-3-2	Bill printing preview	263
23.	Low Noise Operation	264

Appendix

24.	Product Specifications	267
24-1	Operating condition	267
24-2	Specifications	268
25.	Troubleshooting	269
25-1	Troubleshooting	269
25-2	Error code table	271
26.	FAQ	272
26-1	Frequently asked questions and answers	272
26-2	Questions and answers related to electricity charge apportionment	274
27.	Definition Of Terms	275

“**AIRSTAGE**” is a worldwide trademark of FUJITSU GENERAL LIMITED and is a registered trademark in Japan ,the U.S.A and other countries or areas.

*Microsoft® and Windows® are registered trademarks of Microsoft Corporation in the United States.

*Adobe® Reader® are registered trademark of Adobe Systems Incorporated in the United States.

*Intel®, Pentium® and Celeron® are registered trademark of Intel Corporation or its subsidiaries in the United States.

*Echelon®, LONWORKS®, and the Echelon logo are trademarks of Echelon Corporation registered in the United States and other countries.

1. Usage Precautions

1-1 Precautions when using the System Controller

1. Please read and agree to the LICENSE AGREEMENT FOR “SYSTEM CONTROLLER FOR VRF SYSTEM” at the beginning of this manual before using the System Controller.
2. Please confirm that the PC for the System Controller meets the operating condition of the “Product Specifications” described in the Appendix of this manual.
3. Please read and fully understand this manual before using the System Controller.
4. Be careful not to shutdown or turn off the power supply of the server pc or unplug its transmission adaptor. Do not terminate the VRF Controller program unless necessary. Otherwise, normal operation of the System Controller may not be performed.
5. To ensure continuous normal operation of this software, set the PC so that it would not go into an energy saving mode such as standby mode, sleep mode or execute hibernation. If the PC goes into a standby, sleep mode or execute hibernation, this software may not function properly. The method for releasing the energy saving or hibernation of the PC depends on the Windows versions.
6. The DVD for this software and the software protection key (WIBU-KEY) will not be reissued. Keep and handle them with great care after installing.
7. System Controller programs perform schedules, operation recording and electricity apportionment data control based on date and time set in the personal computer. Please correct the time periodically to make the date will not be changed. Changing date and time may affect the functions listed above.
8. When program execution environment of Windows is corrupted or abnormal, or if other software is installed or running on the same PC, operation of System Controller may be interfered and may not install or run properly. It is usually extremely difficult to detect such conditions, if it occurs. It is recommended that System Controller be installed on a new PC, dedicated for the use of System Controller.
9. System Controller product is provided with software, drivers, components listed below. If the same kind of software, drivers, components with different version is installed on the same PC, System Controller may not install or run properly.
 - (1) Microsoft® DirectX® 9.0c
 - (2) Microsoft® SQL Server®
 - (3) OpenLDV (U10 USB Network Interface driver)
 - (4) WIBU-KEY driver
10. The VRF Explorer is not guaranteed to work using the Remote Desktop. Do not connect to the PC running VRF Explorer, using Remote Desktop.
11. This product may be updated without prior notice. If by chance you encounter any trouble with this product, check with your dealer for updates.

2. How To Use This Manual

2-1 Manual composition

This manual is made up of 7 sections.

- Introduction
- Server PC Installation
- Client PC Installation
- Settings
- VRF Controller Operation
- VRF Explorer Operation
- Appendix

Before installing the software, first read the Introduction and check the overview of the system controller and the caution items. For technical terms, refer to the definition of terms in the Appendix.

When installing the system controller to the server PC, read the Server PC Installation and Settings sections. Complete installation to the server PC in accordance with the described procedure.

When installing to the client PC, read the Client PC Installation section. Finish installation to the client PC in accordance with the described procedure.

When performing operations related to the various functions of the system controller after installation, refer to the relevant parts of the operation sections (VRF Controller Operation and VRF Explorer Operation).

When you want to see the corresponding description even in an operation case that used the system controller, refer to Standard Operation Case at the head of the VRF Explorer Operation Section.

The Appendix is made up of product specifications, troubleshooting, FAQ, and definition of terms. Read them as required.

Introduction

3. Overview
4. Materials To Be Prepared Beforehand

3. Overview

3-1 Features

1. Configuration and performance befitting the VRF highest level control/management functions

- ① Supports VRF Series S/V-V-II/J-II/VR-II
 - Different series can be mixed at network systems
- ② Scalability supports all sites from small scale to large scale
 - Supports up to 4 network systems (equivalent to 1,600 indoor units).
- ③ Functional high level interchangeability with other VRF controllers
- ④ Remote monitoring and control function
 - Remote monitoring and control function supports VRF system operation from up to 5 remote sites.
 - * Note) Dedicated software must be installed at the remote site.
- ⑤ Remote central management function
 - Central management (up to 10 places) of VRF air conditioning system of multiple VRF sites supports building operation energy saving.
- ⑥ Improvement of electricity charge apportionment function
 - The apportionment function has been improved by adopting an electricity charge apportionment calculation method matched to V-II/J-II/VR-II Series refrigerant control.
- ⑦ Refined user interface
 - The status of units can be monitored and operated from site, 3D building, floor, and other multiple layouts.
- ⑧ Refined group operation
 - Hierarchal tree structure free group definition is possible. Status monitoring and operation that specified groups from a tree view on the screen are possible.

2. Adaptation for new PC environment

- ① Operation on Windows 7, is guaranteed.
- ② Supports compact and lightweight USB transmission adaptor (U10 USB Network Interface adaptor).

3-2 System Controller composition

The System Controller consists of VRF Controller (Server software) and VRF Explorer (Client software). Each software is used according to its role.

VRF Controller and VRF Explorer are installed to the Server PC.

VRF Explorer is installed to the Client PC.

Server PC	PC which is directly connected to the VRF System by using a U10 USB Network Interface. Server PC is the PC in which VRF Controller is installed and run. A VRF Explorer is also installed to the server PC, and the user can manage VRF System operation by server PC.
Client PC	PC which is connected to a server PC over an internet or other network and manages operation of the VRF System via the server PC. VRF Explorer is installed and run.
VRF Controller (Server software)	One of the 2 programs making up the System Controller. It communicates with the VRF System and passes status information to the VRF Explorer and receives operation setting information from the VRF Explorer. Since the user provides service to the client software (VRF Explorer) used to actually manage operation, it is called server software. Since it is run in the background on the PC, it is difficult to realize that it is running and when running, an icon appears on the task tray. Operations which can be performed by the user related to the VRF Controller are related to menus which are displayed by right clicking the icons on the task tray. The VRF Controller must be used together with a WIBU-KEY packed with together with this product.
VRF Explorer (Client software)	One of the 2 programs making up the System Controller. It is software used by the user to actually manage operation. Since it communicates with a server directly connected to the VRF network and is run by receiving service from the server, it is called client software. VRF Explorer mainly consists of two screens: Site Navigator screen for monitoring group site and VRF Explorer main screen related to a specified site in it. Using this product (VRF Explorer included on the server PC), VRF Explorer can be installed on an unlimited number of machines.

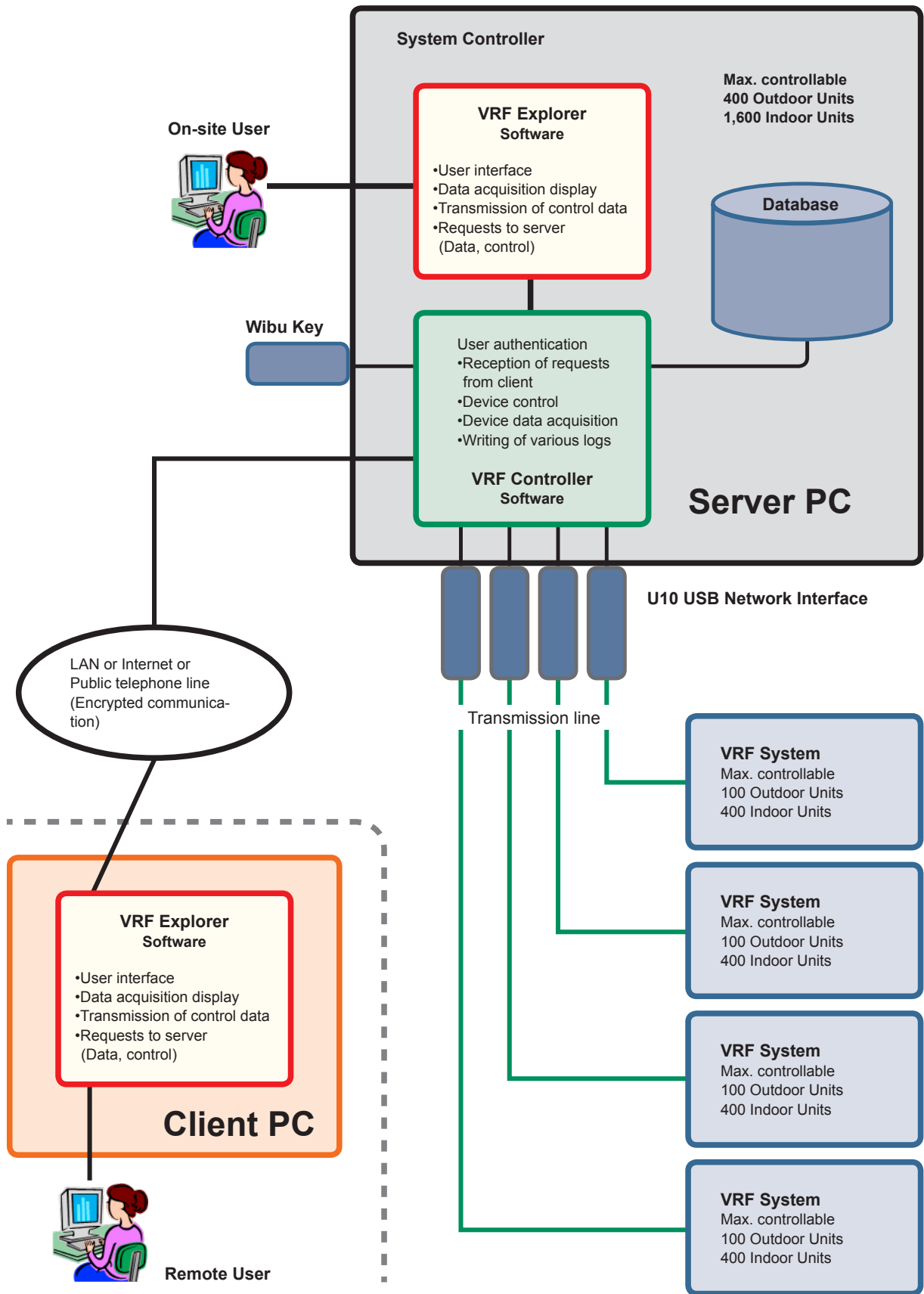

3-3 Example of use

1. Use with 1 server (1:1 connection)

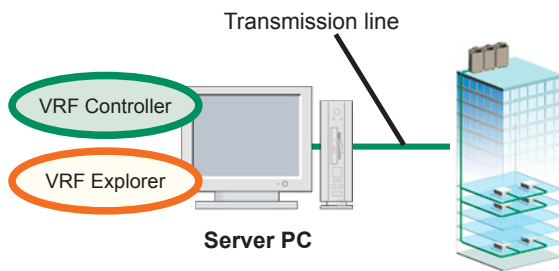

2. Remote monitoring and control (n:1 connection)

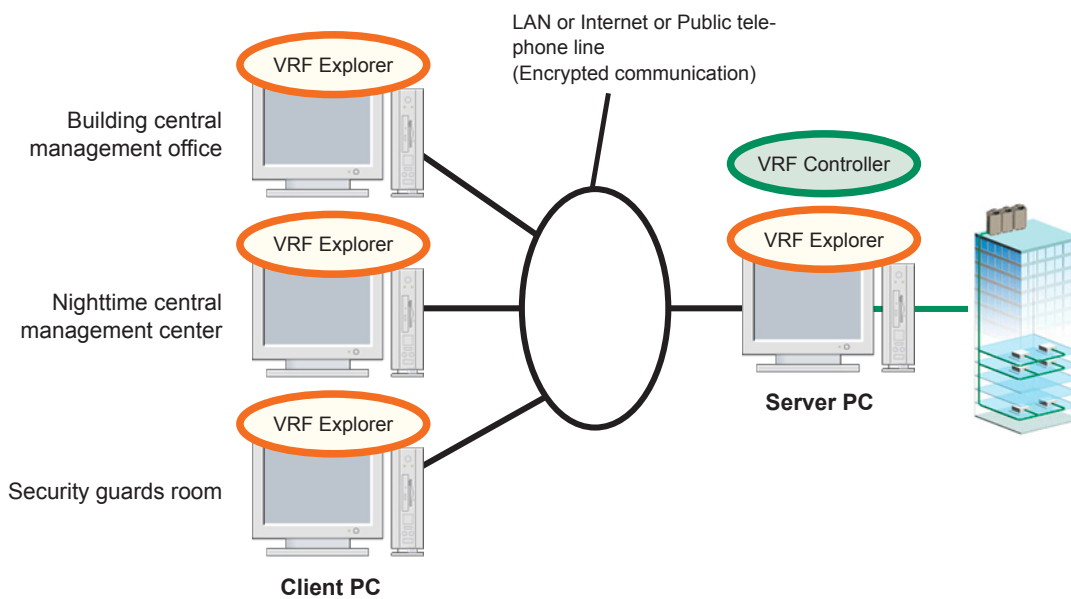

3. Remote central management (1:n connection)

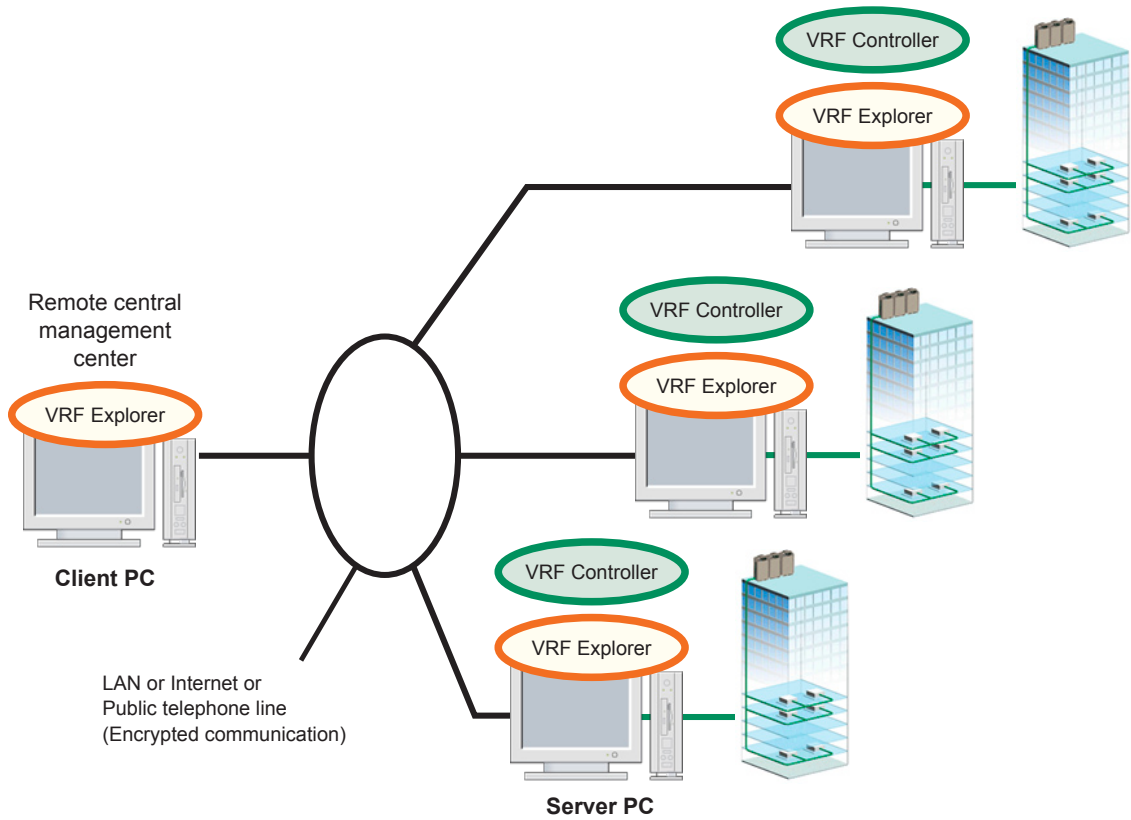

Note

- Up to 5 client PC can connect to the server PC at the same time.
- Up to 10 server PC can be registered at a client PC.
- When a telephone line is used, the connection between server PC and client PC becomes 1:1.

3-4 Function list

* Meaning of symbols of "Remote function" column. ○---Same function as local control / ×---No function

Type	Function	Overview	Objective Series		Remote function
			S/V	V-II/J-II/VR-II	
Centralized management	Multiple site display	Overall display of multiple sites so that forget to turn off/error generation can be monitored in site units. Allows registration of up to 10 sites.	○	○	○
Status monitoring	Site display	Overall display of multiple sites so that forget to turn off/error generation can be monitored in building units. Allows registration of up to 20 sites.	○	○	○
	Building 3D display	Performs 3D layout display of buildings in building units and displays the operation status (On/Off/Error/Test/Emergency stop) of attributed R/C group. Also allows operation control in overall buildings, floor units, and R/C group units.	○	○	○
	Floor display	Performs the display of indoor unit operation status in floor units. Also allows operation control in floor units, and R/C group units.	○	○	○
	List display	Displays the operation status of the indoor units and outdoor units of the selected building in list format. Also allows operation control.	○	○	○
	Tree display	Displays the groups set at the selected building by tree structure. Also allows display of operation status (On/Off/Error/Test/Emergency stop) and operation control in R/C group units from on a tree.	○	○	○
Error management	Error notification	Displays error information on a pop-up screen when an error occurs.	○	○	○
	Error e-mail notification	Notify the error information by e-mail when an error occurs.	○	○	×
History management	Error history	Allows display of the error history of each indoor unit and outdoor unit.	○	○	○
	Operation history	Display indoor- and outdoor-unit operating histories.	○	○	○
Operation control	Control	Allows control of selected indoor units by the following operations: •On/Off •Operation mode •Room temperature setting •Air flow rate and direction •Economy (energy save)	○	○	○
	Management	Allows management of selected indoor units by the following operations: •R/C prohibition •Temperature upper and lower limit setting •Filter sign reset	○	○	○
	Memory operation	Saves 1 operation setting state of an entire building and reproduces it with 1 button. (Reproduction of special operation pattern at the start of work is assumed)	○	○	○
	Pattern operation	Saves 1 operation setting state of the operation control screen and reproduces it with 1 button. (Shot of setting reset when hotel room vacated is assumed)	○	○	○

Type	Function	Overview	Objective Series		Remote function
			S/V	V-II/J-II/VR-II	
Operation control	Temperature upper and lower limit setting	Sets the upper and lower limits of the indoor unit set temperature.	×	○	○
Schedule	Schedule timer	Yearly/weekly schedule setting is possible. Week of year, Day of month, Day of week, holiday/special day setting is possible.	○	○	○
	Low noise operation	The low noise mode set to the outdoor unit is executed by the weekly schedule.	×	○	○
Scanning	Adaptor setting	Communication adaptor (U10 USB NetWork Interface) used to set the connection to VRF Controller. The name setting and the connection status of the communication adaptor can be confirmed.	○	○	×
	Unit registration	Acquires model data of indoor units and outdoor units of a specified refrigerant system. (Model data: Node identification included).	○	○	×
	Unit name registration	Assigns a unique management No. to indoor units acquired by scanning and associates logical address and physical address. Presents 3 kinds of allocation: default name allocation, manual allocation, and automatic allocation in the order of indoor unit operation.	○	○	×
	Group setting	Performs allocation setting of up to 1,600 groups in 3 nodes.	○	○	○
	Layout editing	Performs building 3D display and floor layout editing.	○	○	○
Electricity charge apportionment	Apportionment charge calculation	Calculates the power consumption charge for each tenant according to the apportionment related setting conditions and operation status of each indoor unit.	○	○	○
	Apportionment charge bill creation	Allows issuance of predefined bills for charges for each tenant calculated at the calculated result screen of the electricity charge apportionment function.	○	○	○
	Tenant (block) setting	Allocates tenants and indoor units which are the objective of electricity charge apportionment.	○	○	○
	Common facilities apportionment setting	Allocates tenants (blocks) which become common facilities at electricity charge apportionment. Also allows apportionment of allocated tenant power consumption to tenants other than common facilities.	○	○	○
	Externally linked devices setting	Arbitrarily sets the various power consumptions (w) which are necessary at electricity charge apportionment. (Objective: Externally linked devices which are connected to indoor unit or outdoor unit)	×	○	○
Others	User management setting	Sets the user name and user authorization which become the operation objective.	○	○	○
	User environment setting	Performs display related environment setting.	○	○	○
	Import/export of database	Allows import/export of database for smooth environmental transition when a PC is replaced.	○	○	×
	Import/export of layout data	Allows import/export of layout data for smooth customer introduction by building layout data provided in advance.	○	○	×

4. Materials To Be Prepared Beforehand

Materials necessary at installation

- Work drawings or unit layout
- Site building layout map (used in building layout)
- Diagram of each floor (used in floor layout creation)
- WIBU-KEY (packed together with product)
- U10 USB Network Interface (adaptor with connection to VRF network work finished)
- Administrator ID and password (arbitrarily decided by the user)
- System Controller setup DVD (For details, see the next page.)

When number of USB ports for WIBU-KEY and U10 USB Network Interface use is insufficient

- USB hub

In the case of remote connection (server PC continuously connected to local LAN)

- IP address for connection to server PC

In the case of remote connection (server PC continuously connected to internet)

- Server PC fixed IP address, or Host name when dynamic DNS used.
- Confirmation of opening to internet of ports used by system controller (port No:9983, 9984)
- * When unknown, please contact the network administrator.

In the case of remote connection (dial-up)

- Telephone number for connection to server PC

When starting electricity charge apportionment data acquisition

- Group apportionment contents of tenant blocks
- Electricity charge contract information

When making settings which send e-mail notification when an error occurs

- E-mail address (sender, receiver)
- SMTP server name

Setup DVD configuration (Reference)

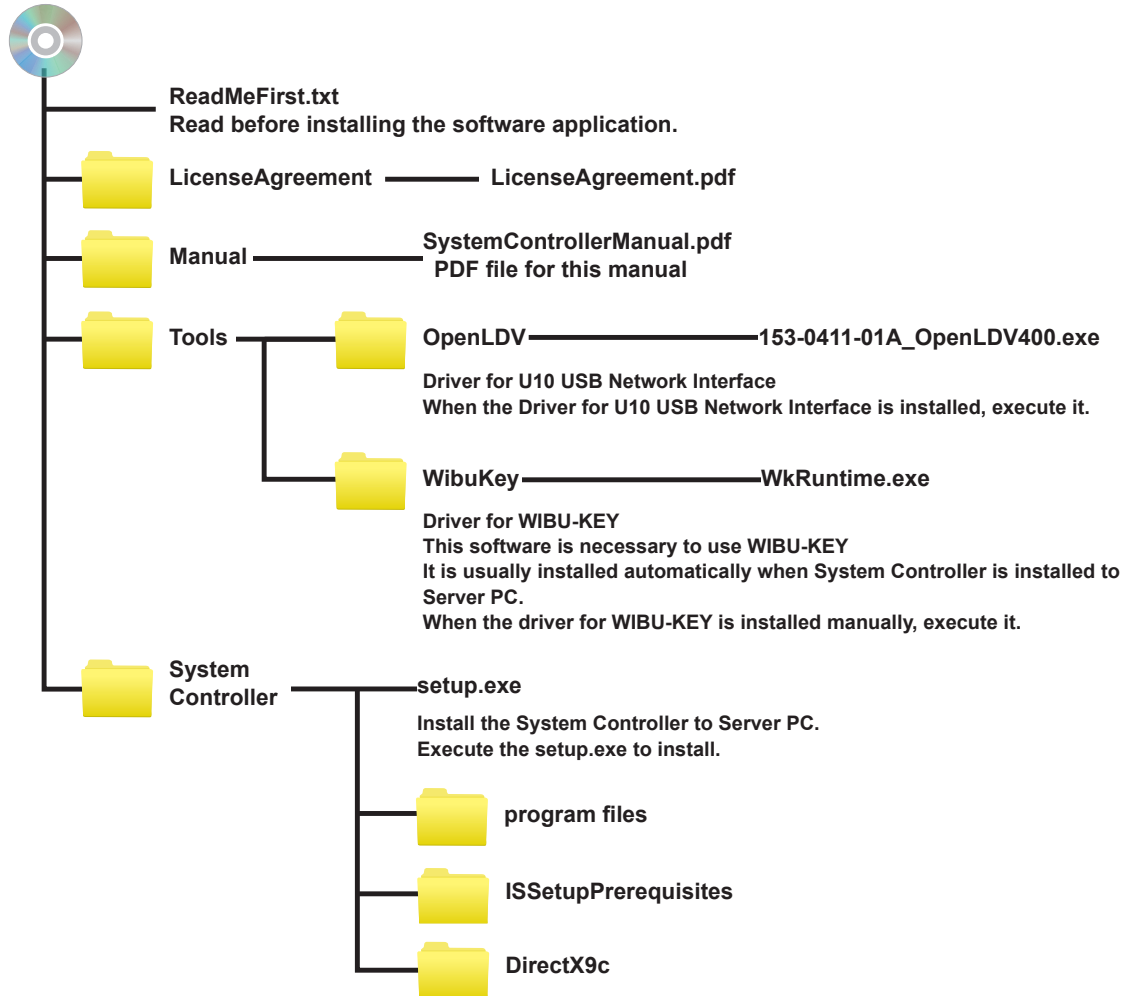

Server PC Installation

5. Installation (Server PC)

5. Installation (Server PC)

This section describes the procedure when installing the server software (VRF Controller), and client software (VRF Explorer), etc. of System Controller to the server PC which connects directly to the VRF network. The server PC communicates directly with the indoor and outdoor units. Installation to a server PC is always necessary from the standpoint of System Controller use.

The server PC and VRF network are connected by a transmission adaptor (U10 USB Network Interface).

This section describes how to uninstall the software when server software is unnecessary and how to reinstall the installed software due to software upgrading or other reasons.

5-1 Installation flow

Installation/setting flow

Installation

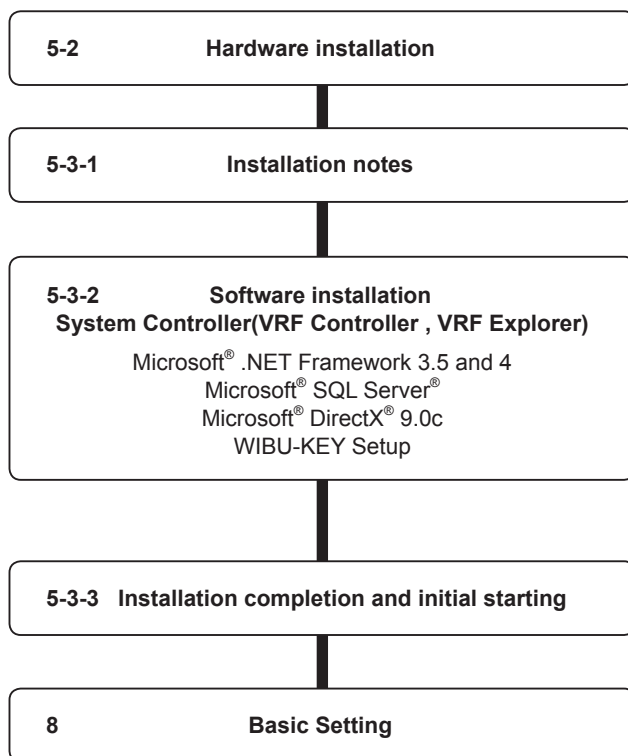

WARNING!

- ① System Controller is tested to install and operate under new Windows environment. When program executional environment of Windows is corrupted or abnormal, or other softwares that interfere with the operation of System Controller is installed or running, System Controller may not install or run properly. It is usually extremely difficult to detect such conditions, if it occurs.
- ② System Controller product is provided with softwares, drivers, components listed below. If the same kind of softwares, drivers, components with different version is installed on the same PC, System Controller may not install or run properly.
 - (1) Microsoft® DirectX® 9.0c
 - (2) Microsoft® SQL Server®
 - (3) Open LDV (U10 USB Network Interface driver)
 - (4) WIBU-KEY-driver
- ③ Do not insert U10 USB network interface adaptor to the USB slot of the PC BEFORE its driver is installed.
- ④ Do not turn on the power of indoor/outdoor units until all installation work is completed.
- ⑤ Do not insert WIBU-KEY to the USB slot of the PC until instructed.

5-2 Hardware installation (transmission adaptor)

5-2-1 Transmission adaptor installation

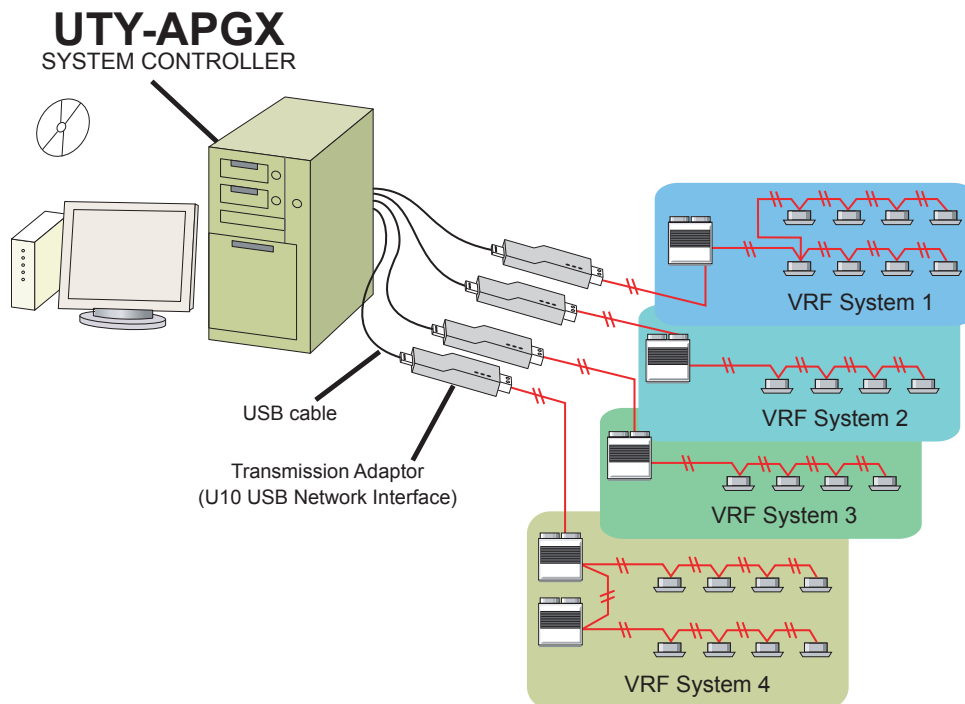

The System Controller can connect up to 4 VRF systems. Since 1 transmission adaptor connects to 1 system, up to 4 transmission adaptors are connected.

Following chart shows the detail of the U10 USB Network Interface Adaptor. These adaptors are not included in the System Controller product and must be procured in advance.

Name & Shapes	Q'ty	Remark
Transmission Adaptor (U10 USB Network Interface -TP/FT-10 Channel)  (Field Supply)	1 to 4 procure the necessary number in accordance with the number of connection systems.	Model : 75010R (Echelon® Corporation)

It is necessary that set Transmission adaptor respectively because of the S/V series and V-II/J-II/VR-II series can not be connected to the same communication line.

Installing U10 USB Network Interface Adaptor

To use this product, turn on the power of the PC and install necessary drivers/software for this product (BEFORE connecting it to any USB port), following the "Quick Start Guide" enclosed with this product.

Note

"OpenLDV 4.0 Network Driver" or newer is required

- When using multiple U10 USB Network Interface adaptors, confirm in advance, which U10 USB Network Interface adaptor connects to which VRF Network (Attach labels to the U10 USB Network Interface adaptors if possible). These information will become necessary during the setup procedure of System Controller (You will be required to specify which U10 USB Network Interface adaptor corresponds to which VRF network).

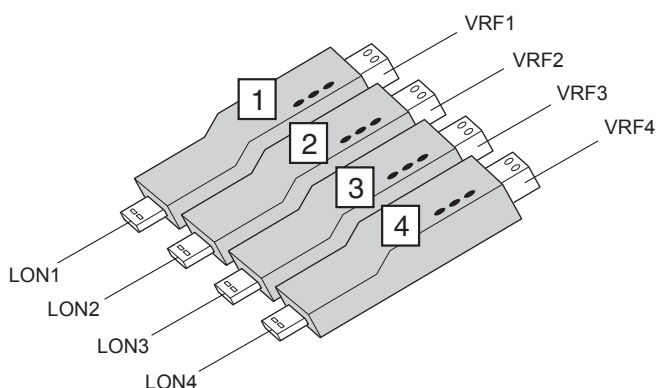

Keeping a record of a table such as shown below is recommended.

LON No.	Adaptor No.	VRF System No.
LON1	Adaptor 1	VRF 1
LON2	Adaptor 2	VRF 2
LON3	Adaptor 3	VRF 3
LON4	Adaptor 4	VRF 4

Note. "LONx" is used to identify U10 USB Network Interface adaptor. LON numbers are given in the order they are inserted to a PC for the first time and basically, never changes, even if you change USB slot afterwards.

- Connect the U10 USB Network Interface adaptor to the personal computer USB port. When there are multiple U10 USB Network Interface adaptors, connect each U10 USB Network Interface adaptor in the order of its LON number.

5-2-2 Wiring and turning on the units power

Once the wiring has been installed, the power can be turned on. Follow the procedure below for turning on the power.

- ① Connect VRF network cables to the corresponding U10 USB Network Interface adaptors.
- ② Turn on the power for all connected indoor units.
- ③ Turn on the power for all connected outdoor units.

Note

- *1. Make sure that USB equipment (USB hub, etc.) that this product is connected to, is not overloaded (power supplied thru the interface does not exceeds the maximum limit).

- ④ Turn on the power for System Controller PC, if it is not yet turned on.

5-3 Software installation (applications, drivers)

5-3-1 Installation notes

Before starting the installation of this product, check each of the followings.

- Install Adobe Reader (Ver. 9.0 or later) prior to the installation. (Adobe Reader does not come with this product).
- Have the installation DVD of the Windows version (Windows Vista or Windows 7) used for the PC ready.
- Remove all program as described in “5-4 Uninstall and version upgrade” , if you have the same or previous version of System Controller.
- Do NOT insert WIBU-KEY (Software protection key) enclosed with this product to the PC until product installation is completed.
- You are required to login to the computer as Administrator (or equivalent) to the PC to install this product.
- Stop all running programs before you start the installation.
- If Anti-Virus software product is installed, temporarily disable the software during the installation of this product.

5-3-2 Software install

The following software is installed here.

- Microsoft® .NET Framework 3.5 and 4
- Microsoft® SQL Server®
- System Controller (VRF Controller , VRF Explorer)
- Microsoft® DirectX® 9.0c
- WIBU-KEY driver

- ① Execute setup.exe in the System Controller folder on the System Controller setup DVD.
- ② Select the same language as that of the Windows® (If you select a different language, characters may not be displayed correctly).

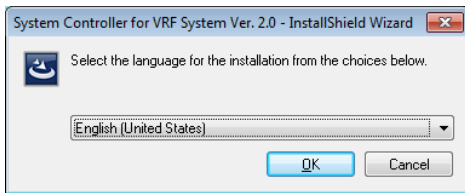

- ③ When "Install" is selected, installation begins.
a When "ReadMeFirst.txt" is selected, ReadMe is displayed.

Note

Be sure to read it for important information.

b When "Manual" is selected, the manual is displayed.

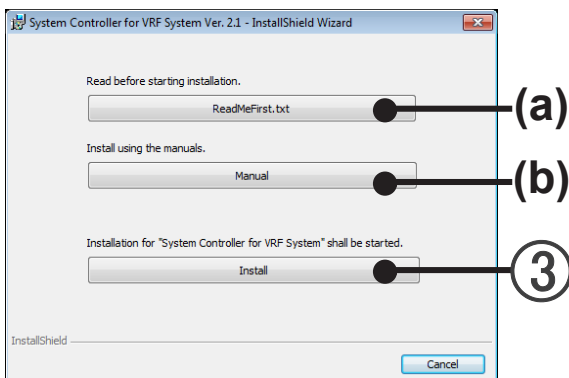

- ④ Install System Controller. Click the [Next] button.

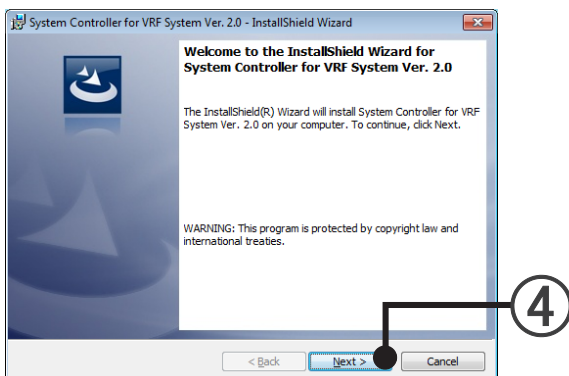

- ⑤ Select "Server (VRF Controller + VRF Explorer)" then Click the [Next] button.

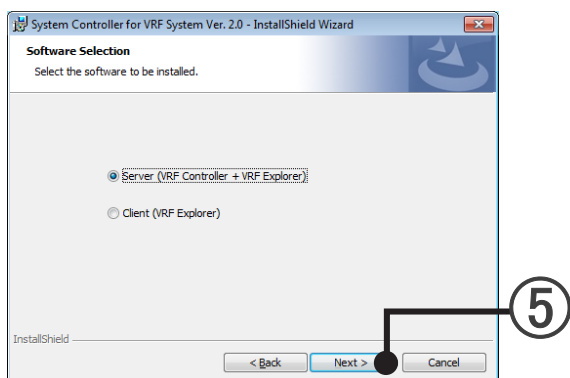

- ⑥ If the System Controller end user "licensing Agreement" is displayed, confirm the contents. If you can agree to the terms of the licensing agreement, check "I accept the terms in the license agreement" and click the [Next] button.

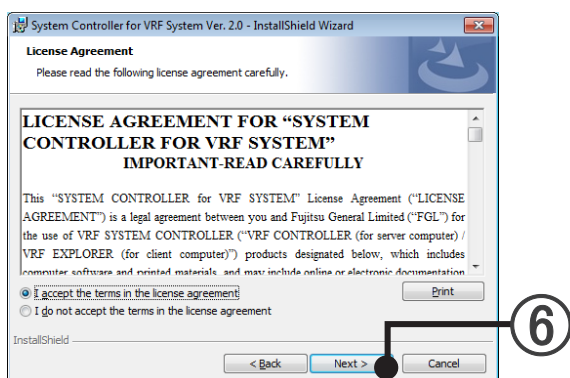

- ⑦ Specify the installation destination folder and click the [Next] button.

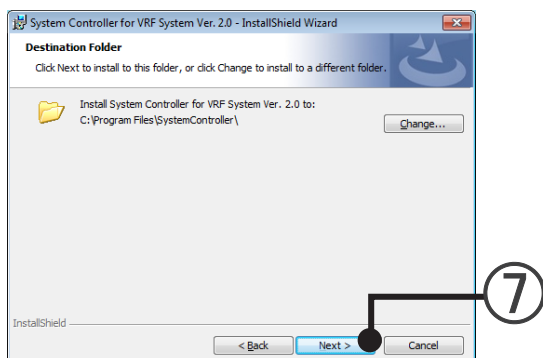

- ⑧ If the installation setting contents are correct, click the [Install] button.

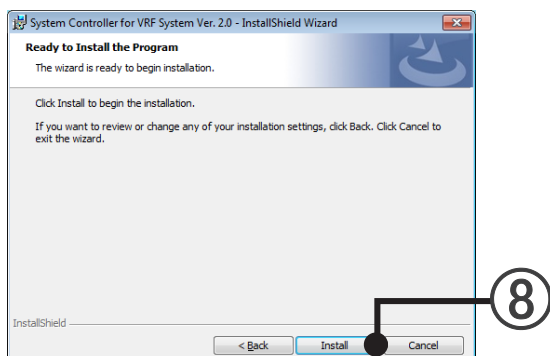

WIBU-KEY Setup

- ① A description of WIBU-KEY Setup is displayed. Confirm the contents. Click the [Next] button.
- ② Select the language. Check the desired language.
- ③ Click the [Next] button.

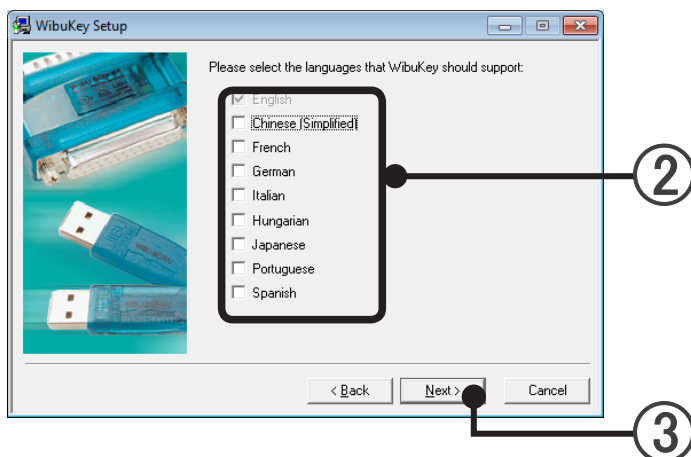

- ④ When the screen to specify the installation destination folder is displayed, specify the installation destination folder and click the [Next] button.
- ⑤ The WIBU-KEY components selection screen is displayed. Uncheck all the checkboxes and click the [Next] button.

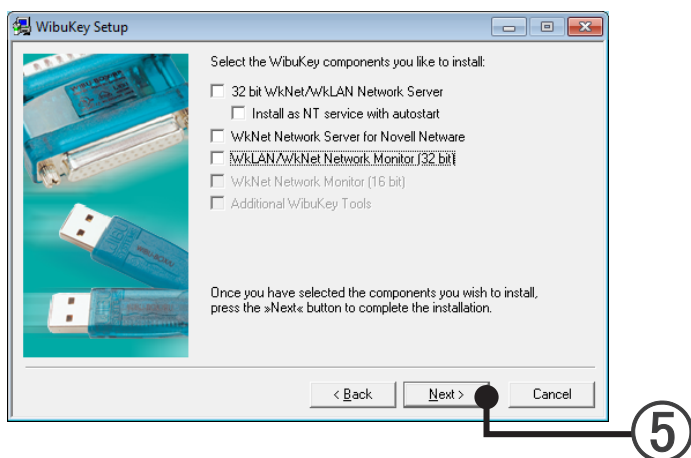

- ⑥ If the WIBU-KEY driver installation contents are displayed, confirm the contents and click the [Next] button.
- ⑦ Installation starts. When [Next] button is enabled, click the [Next] button.

- ⑧ WIBU-KEY Setup is complete.
Uncheck the checkbox and click the [Finish] button.

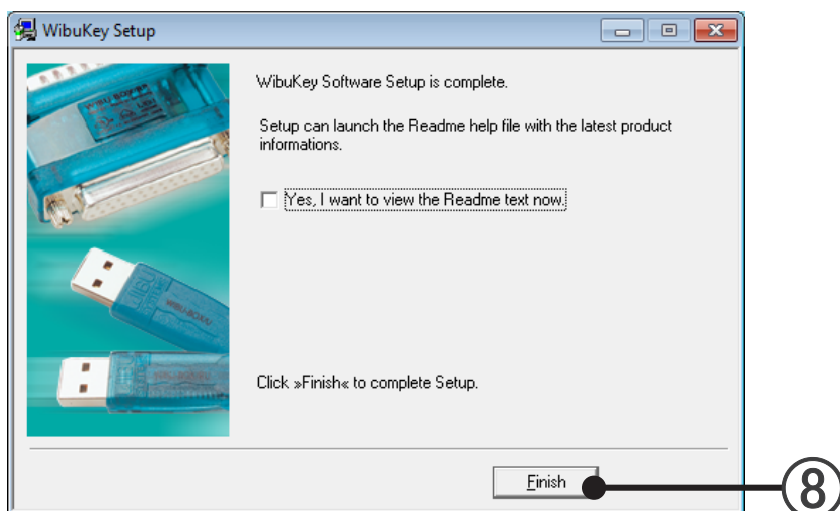

- ⑨ WIBU-KEY Setup was successful.
Click the [OK] button.

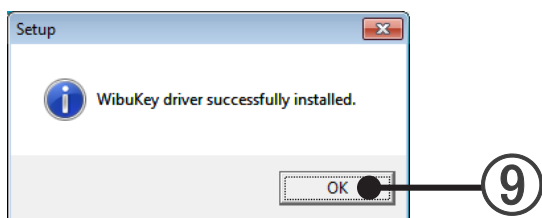

Necessary components for the System Controller such as Microsoft® SQL Server® or Microsoft® DirectX® 9.0c etc will be automatically installed.

5-3-3 Installation completion and initial starting

- ① If this screen is displayed, installation of the System Controller for VRF System (VRF Controller, VRF Explorer) to the Server PC is complete.
Click the [Finish] button.

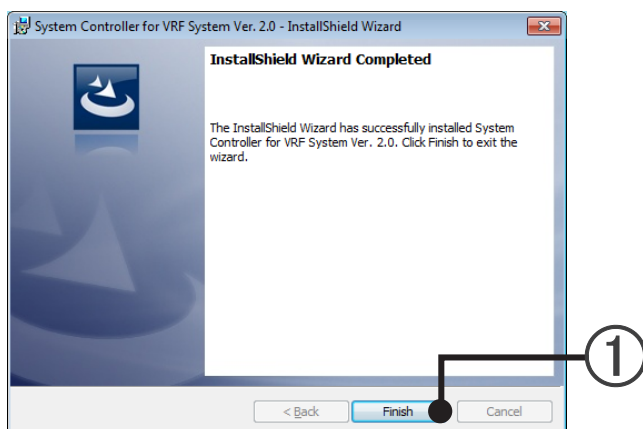

- ② If the Windows® restart confirmation screen opens, click the [Yes] button and restart the server PC.

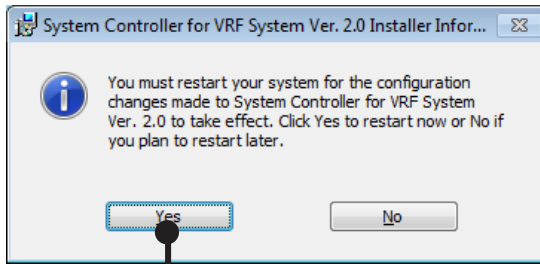

- ③ When server PC restarts, connect U10 USB Network Interface and WIBU-KEY to the USB port.

- ④ The VRF Controller starts.

Select “Start” → “All Programs” → “System Controller for VRF System” → “VRF Controller”.

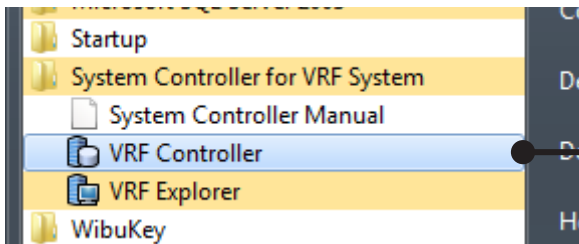

- ⑤ If “Windows Security Alert” is displayed, click the [Allow access] button.

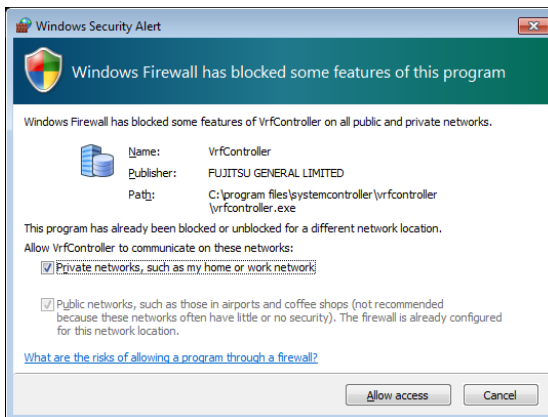

- ⑥ If the “Login Setting” screen opens, perform the initial starting setting.

→ 8. Basic Setting

5-4 Uninstall and version upgrade

For uninstallation and version upgrade in the server PC, follow the procedures shown below.

Note

For upgrade, when the method of upgrading is supplied with the new version of the System Controller, give it priority.

Flowchart for uninstallation and upgrade

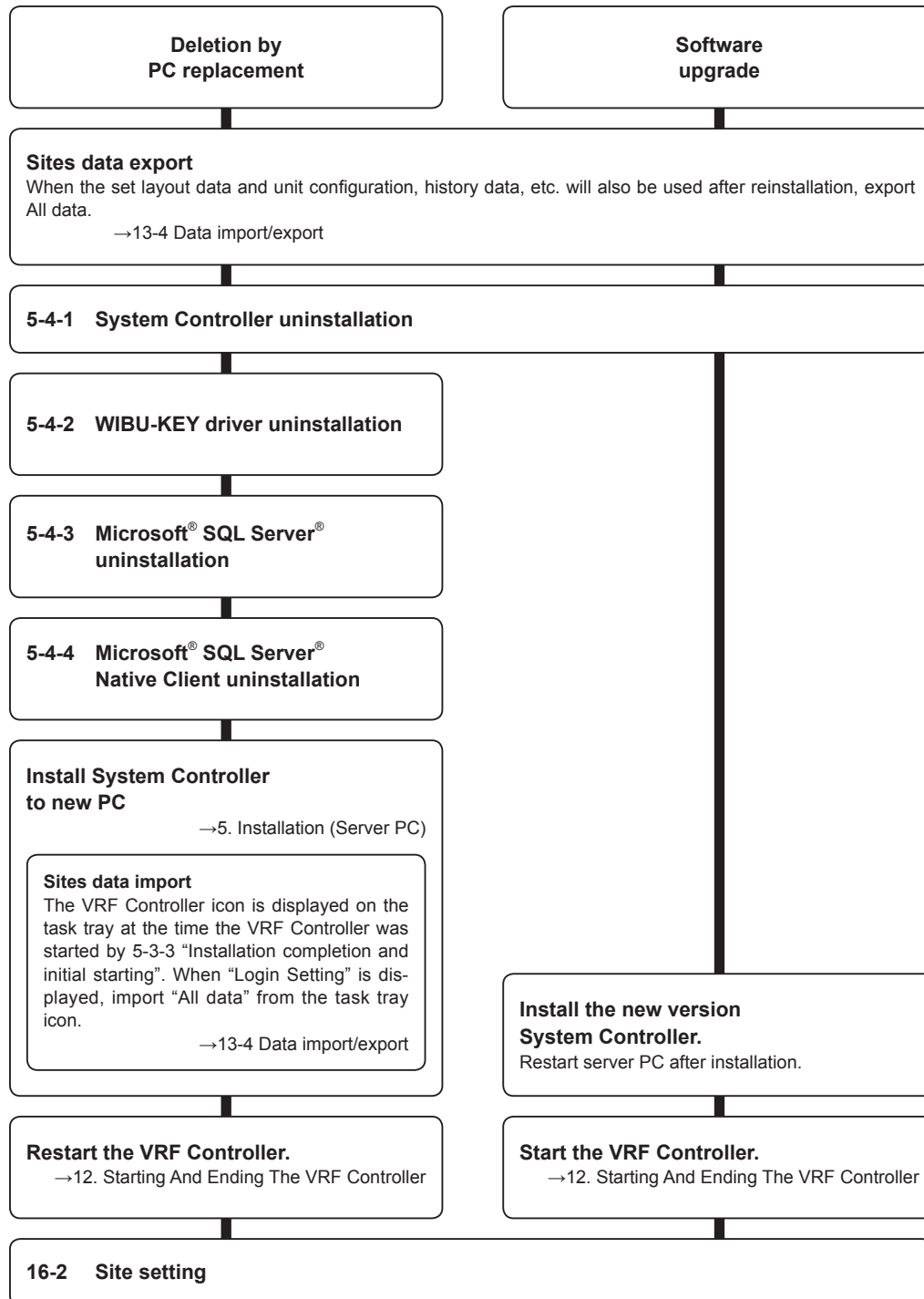

Note

When import is performed for PC replacement, the VRF Controller is disconnected and an error message at the right may be displayed. However, restart the VRF Controller as is.

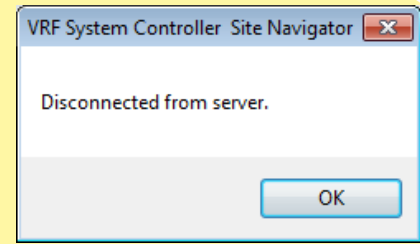

5-4-1 System Controller uninstall

Note

- When the site data during use is expected to be used, export the data before uninstalling the System Controller.
Write all the data by exporting. → 13-4 Data import/export.

- ① Display "start" → "Control Panel" → "Programs and Features".

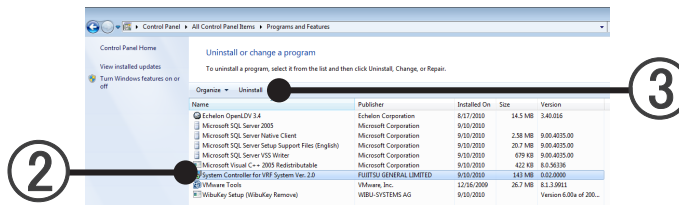

- ② Select "System Controller for VRF System".
- ③ Click the [Uninstall] button.
- ④ When the [Yes] button is clicked, uninstallation begins.

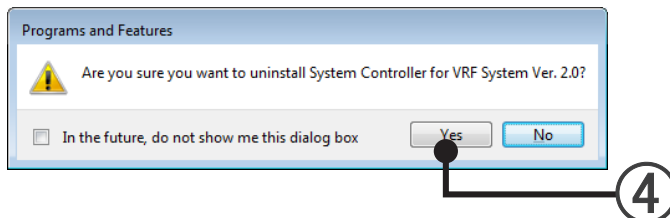

- ⑤ When the screen displaying the uninstallation process closes, uninstallation is complete.
- ⑥ Close the "Programs and Features" screen by clicking the [x] at the top right-hand corner of the screen.
 - * A folder named System Controller remains in the folder designated the System Controller installation folder at installation even though uninstallation is performed.
There is no problem even if this folder remains as is, but it doesn't matter if the folder is deleted.
 - * This completes uninstallation of the System Controller server software (VRF Controller, VRF Explorer), but "WIBU-KEY Setup" and "Microsoft® SQL Server®" remain installed. There is no problem even if they remain, but when you know that other programs will not use "WIBU-KEY Setup" and "Microsoft® SQL Server®", they can also be uninstalled.
 - * When uninstalled even if used by other programs, the other programs will not run properly.

5-4-2 WIBU-KEY driver uninstallation

Execute only when you know for certain that the WIBU-KEY driver is not used by programs other than the System Controller.

If unknown, do not uninstall the WIBU-KEY driver

Remove WIBU-KEY from server PC before uninstalling it.

- 1 Display “start” → “Control Panel” → “Programs and Features”.

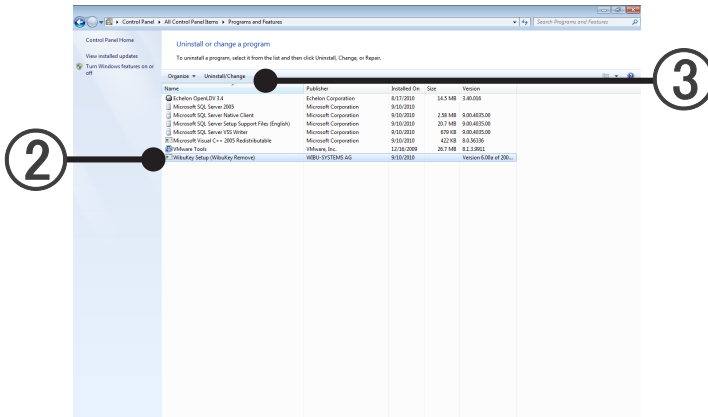

- 2 Delete WIBU-KEY driver.
Select “WIBU-KEY Setup (WIBU-KEY Remove)”.

- 3 Click the [Uninstall/Change] button.

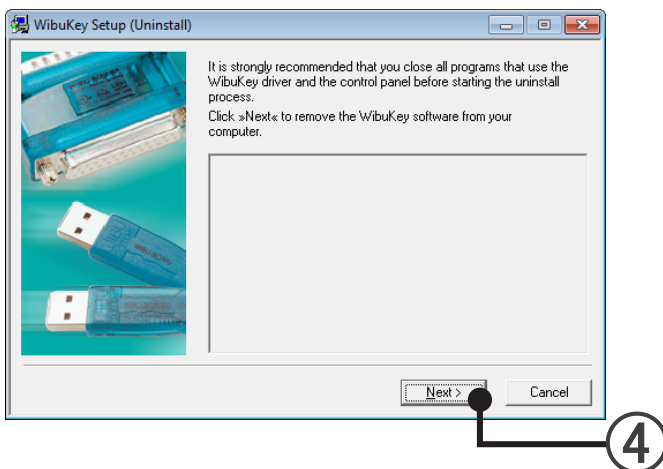

- 4 Click the [Next] button.

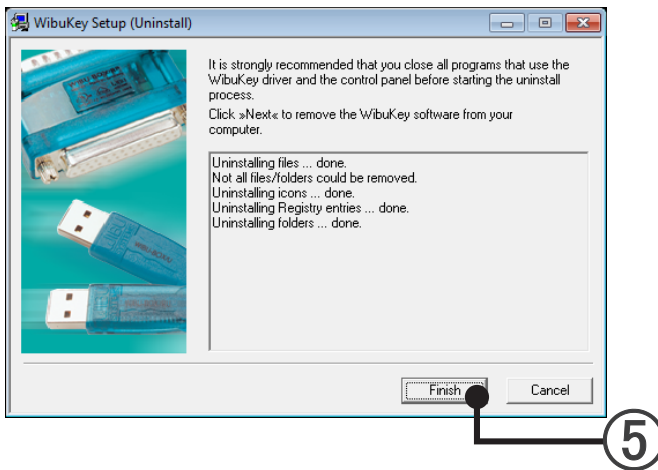

- ⑤ When this screen is displayed, uninstallation of the WIBU-KEY driver is complete. Click the [Finish] button.
- ⑥ Close the “Programs and Features” screen by clicking the [x] at the top right-hand corner of the screen.

5-4-3 Microsoft® SQL Server® uninstallation

Execute only when you know for certain that Microsoft® SQL Server® is not used by programs other than the System Controller.

If unknown, do not uninstall the program.

- ① Select the menu items in order of “start”→“All Programs”→“Microsoft SQL Server 2008 R2”→“Configuration Tools”→“SQL Server Configuration Manager”.
- ② Select SQL Server Services.
- ③ Right-click on SQL Server (SQLEXPRESS).
- ④ Select Stop.

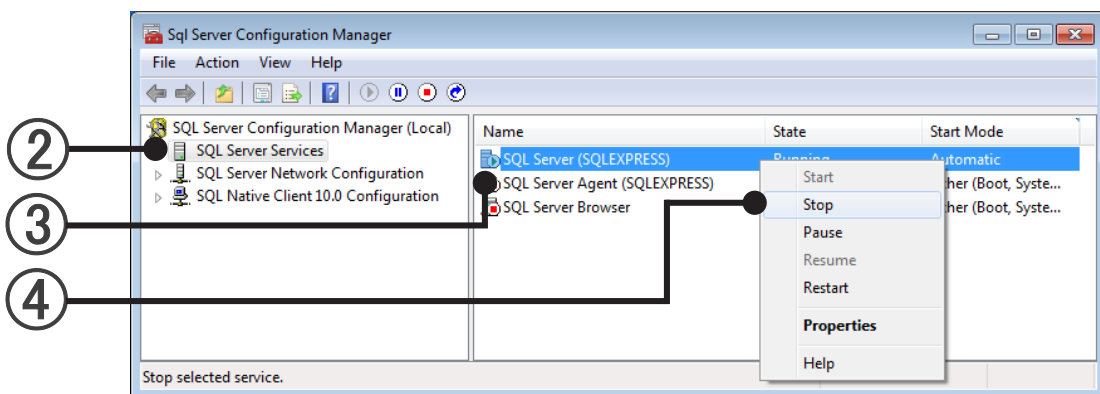

- ⑤ Close SQL Server Configuration Manager with [X].

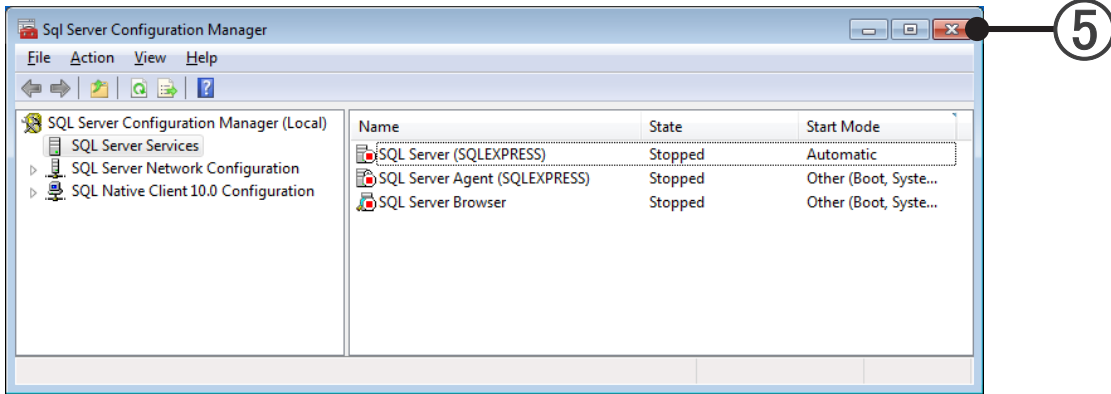

- ⑥ Display “start” → “Control Panel” → “Programs and Features”.

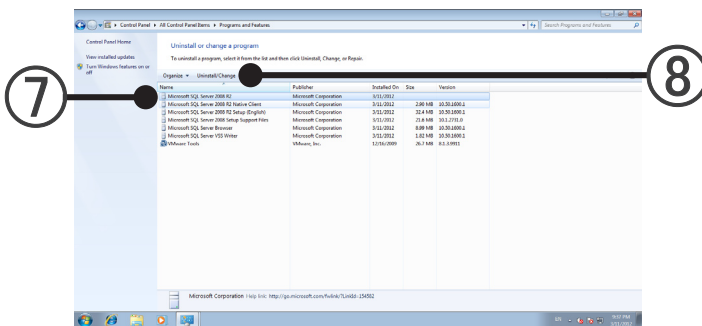

- ⑦ Select “Microsoft SQL Server 2008 R2”.

- ⑧ Click the [Uninstall/change] button.

⑨ Click the [Remove].

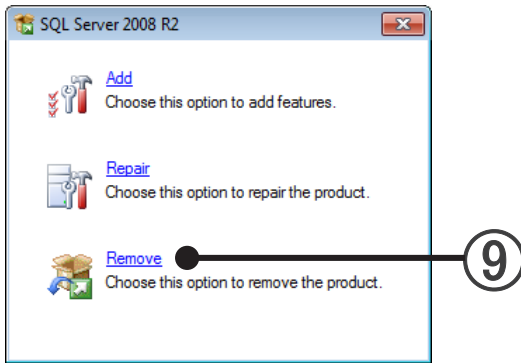

⑩ Click the [OK] button.

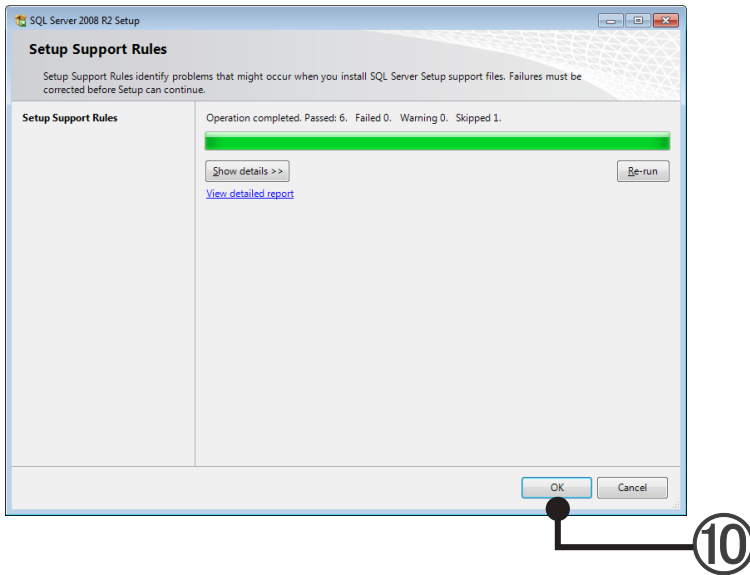

⑪ Click the [Next] button.

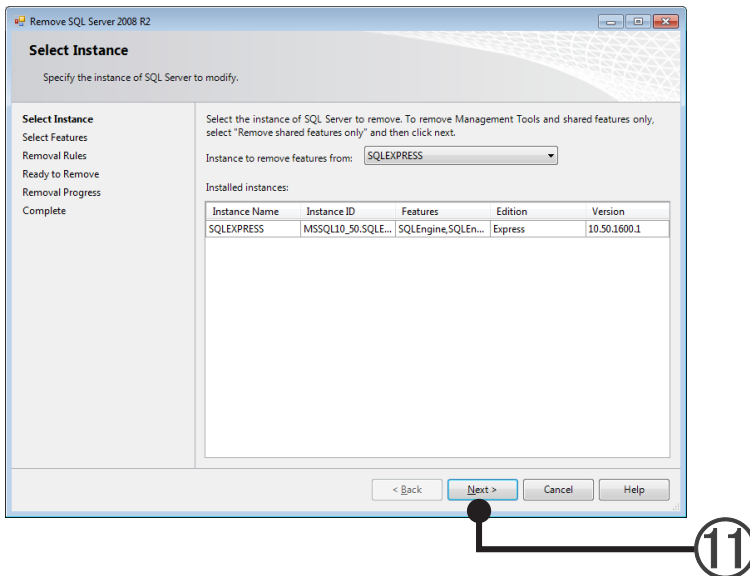

12 Click the [Select All] button.

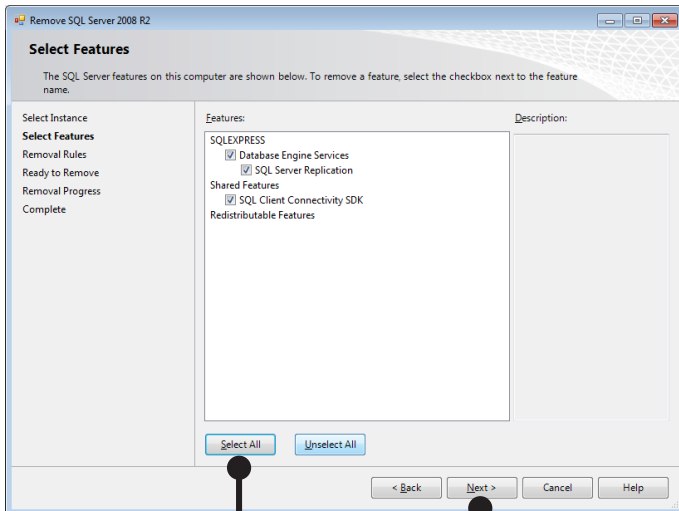

12

13

13 Click the [Next] button.

14 Click the [Next] button.

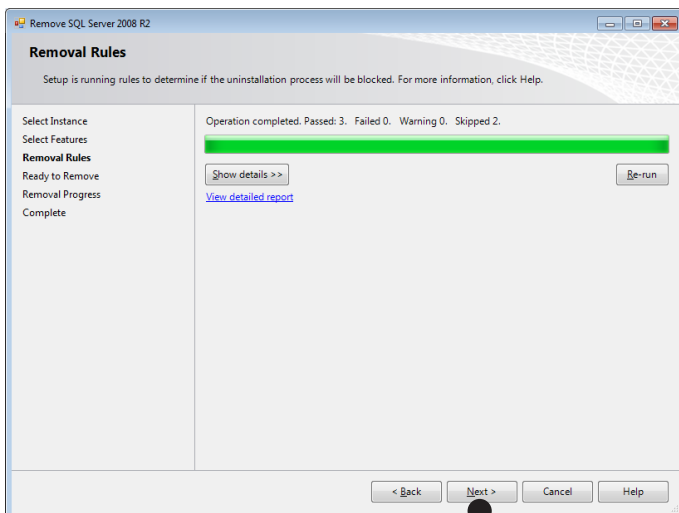

14

15 Click the [Remove] button.

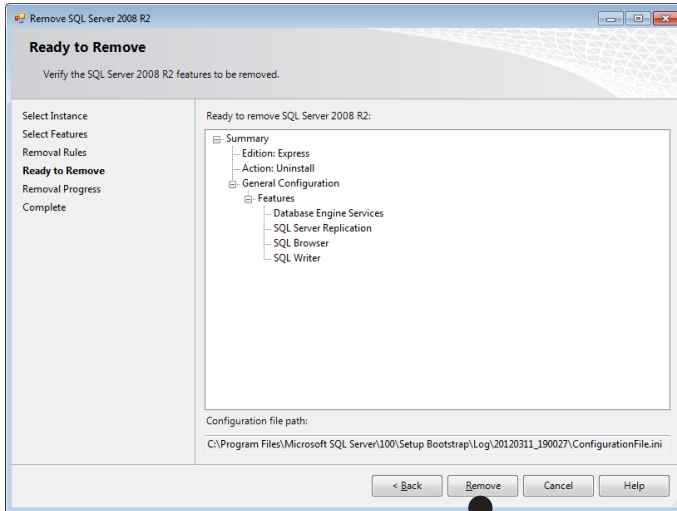

15

16 Click the [Close] button.

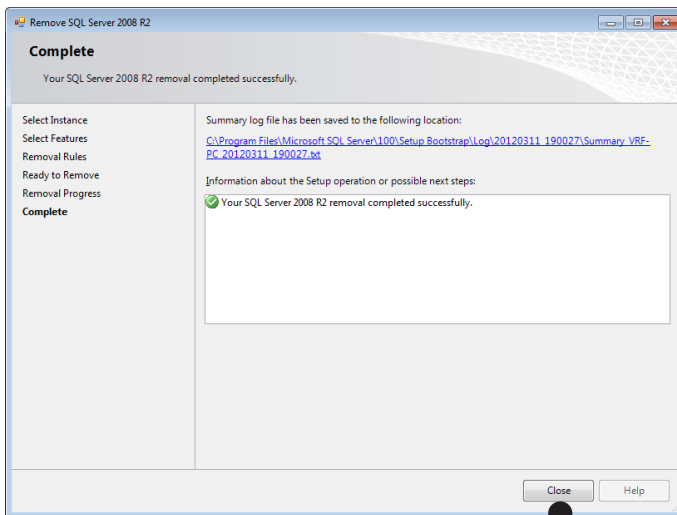

16

17 Close the "Programs and Features" screen by clicking the [x] at the top right-hand corner of the screen.

5-4-4 Microsoft® SQL Server® Native Client uninstallation

Execute only when you know for certain that Microsoft® SQL Server® is not used by programs other than the System Controller.

When unknown, do not execute.

In addition, do not execute when Microsoft® SQL Server® products other than “Microsoft SQL Server” are installed.

- 1 Display “start” → “Control Panel” → “Programs and Features”.

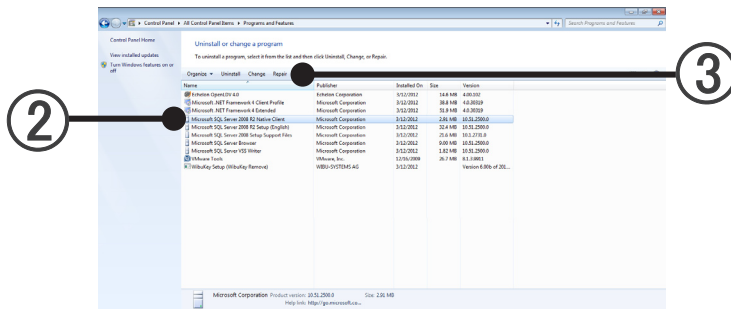

- 2 Select “Microsoft SQL Server 2008 R2 Native Client”.
- 3 Click the [Uninstall] button.
- 4 Click the [Yes] button.

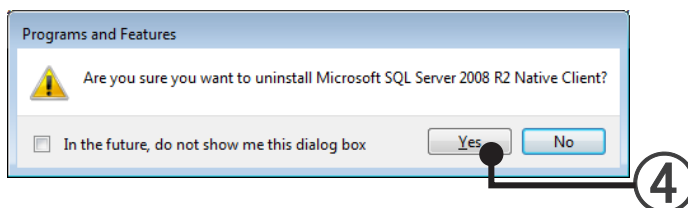

When the screen displaying the uninstall process closes, uninstallation is complete.

- 5 Close the “Programs and Features” screen by clicking the [x] at the top right-hand corner of the screen.

Note

When installing the System Controller, “Microsoft® .NET Framework 3.5” and “Microsoft® .NET Framework 4” may be installed at the same time.

Since “Microsoft® .NET Framework 3.5” and “Microsoft® .NET Framework 4” may also be used by other programs, if it is uninstalled, the other programs may not run properly.

If not inconvenient, do not uninstall “Microsoft® .NET Framework 3.5”, and “Microsoft® .NET Framework 4” and let it remain as is.

Client PC Installation

6. Network Setting
7. Installation (Client PC)

Client PC Installation

This section describes the procedure when installing the System Controller client software (VRF Explorer), etc. to a PC different from the server PC. Generally, this installation is performed when you want to manage and operate sites using a PC at a location separated from the server PC.

This section also describes how to uninstall the software when the client software has become unnecessary and how to reinstall software that has already been installed due to upgrading of the software version or other reason.

Installation flow

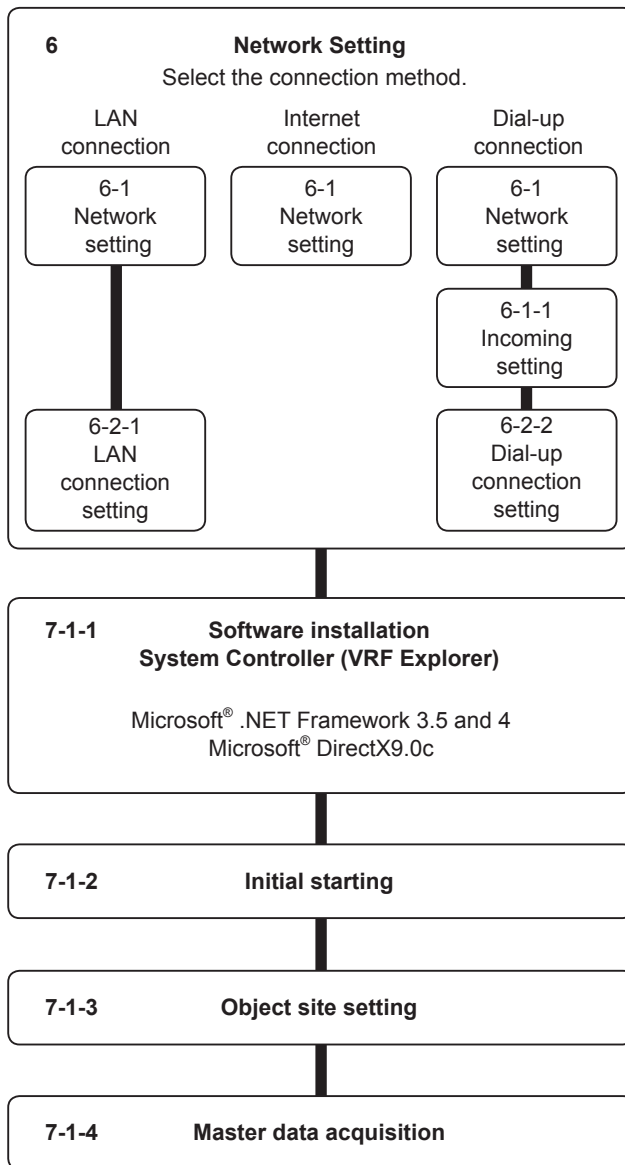

6. Network Setting

To use by installing the System Controller (VRF Explorer only) to a client PC, connection of the network to a System Controller (VRF Controller) installed to a server PC is necessary. There are 3 connection methods.

1. LAN connection (intranet connection)

This method connects the client PC and server PC over a LAN (intranet)

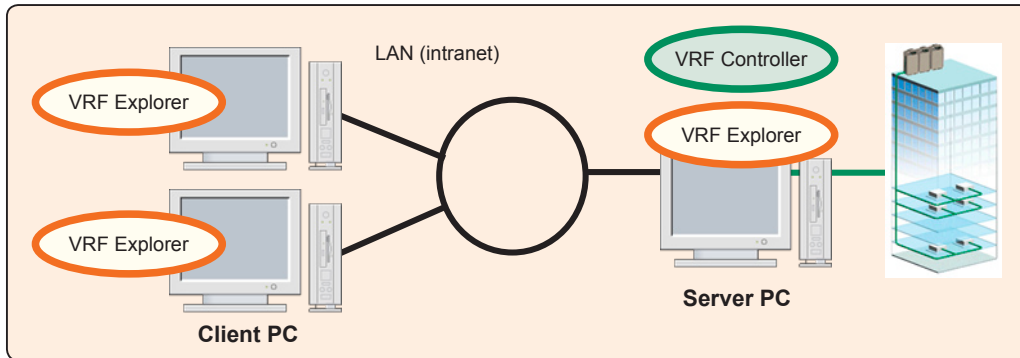

→6-2-1 LAN connection setting

2. Internet connection

This method connects the client PC and server PC over the internet. There is a method which connects to the internet through an intranet and a method which connects to the internet directly through a provider using an access router, etc. without going through an intranet.

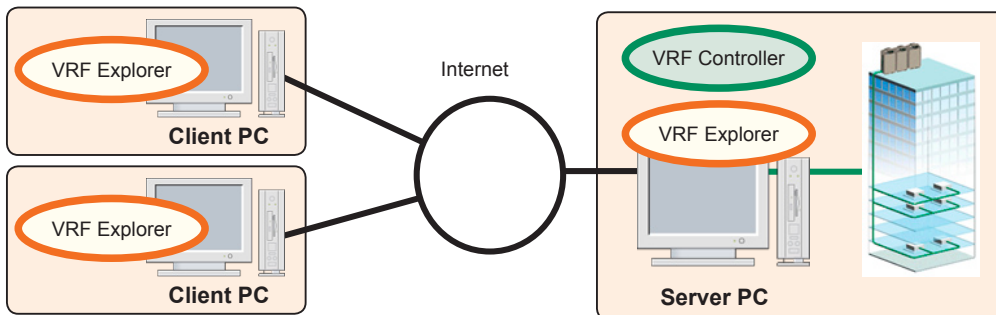

Note

Since a public line internet is used, care must be given to security. A fixed IP which can specify the server PC from the client PC is necessary. When connecting through an intranet, firewall setting is necessary. For details, contact your network administrator.

3. Dial-up connection

This method connects the client PC and server PC by calling a telephone using a telephone line and placing it into the talk state.

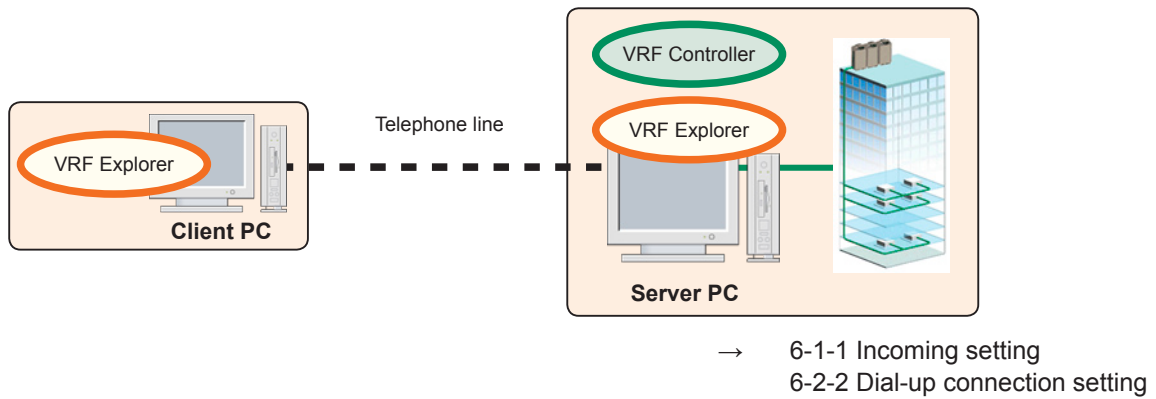

Note

Telephone charges are generated. Since the connection is 1:1, simultaneous connection from multiple client PC or connection to multiple server PC are impossible. Constant monitoring is impossible as long as the telephone is not connected.

6-1 Network setting (server PC side setting)

To exchange data between server and client, perform the following settings (necessary with all connection methods).

Security software setting

When introducing security software, register “VrfController.exe” and “VrfExplorer.exe” at the security software. The setting method differs with the security software.

Regarding the following setting, the necessary settings differ with the server and client connection method. Perform setting after confirming the connection method

1. Internet connection

The permission of the network administrator may be necessary to communicate outside the intranet. Please contact both the server side and client side network administrator.

When connecting through a provider, establishment of a line with the provider is necessary. For details, please contact the provider used. In any case, a fixed IP address is necessary at the server side PC.

2. Dial-up connection

Incoming setting is necessary. → 6-1-1 Incoming setting.

6-1-1 Incoming setting (for dial-up connection)

When the client performs the connecting by dial-up, make the following settings.

■ Modem setting

Perform connection setting based on the connection procedure of the modem to be used.

■ Remote connection setting

Windows Vista

- ① Display the network setting screen by sequentially selecting the menus as follows:
“start”→“Control Panel”→“Network and Internet”→ “Network and Sharing Center”→“Manage network connections”
- ② In the Network Connections screen, press “Alt” key. When the menu bar appear on the top, click “File”, then “New Incoming Connection...”

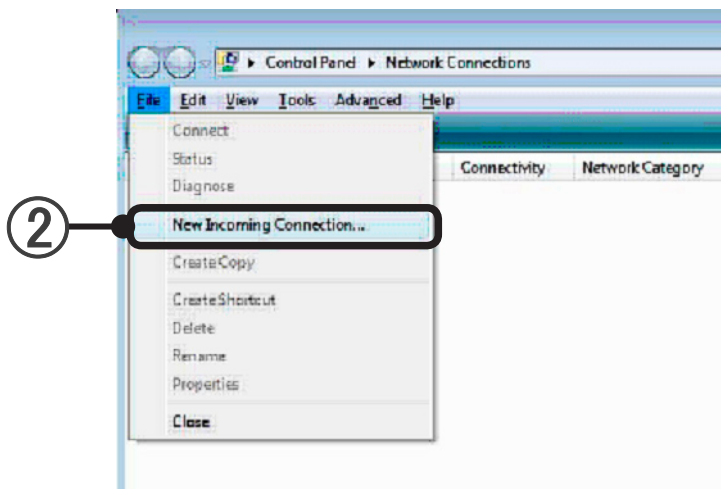

- ③ This screen sets the users who can connect to the computer. The users of the Operating System of the machines are displayed. Check the users allowed to connect from the displayed list. (*1)
Verification is performed by the Operating System at incoming. For connection from the client, the user set here and the password of that user must be input. (*2)
Information

*1. When creating a new user, click [Add someone...] and create the user from the displayed screen.

*2. Perform connection from the client from the screen par. 6-2-2 Dial-up setting.

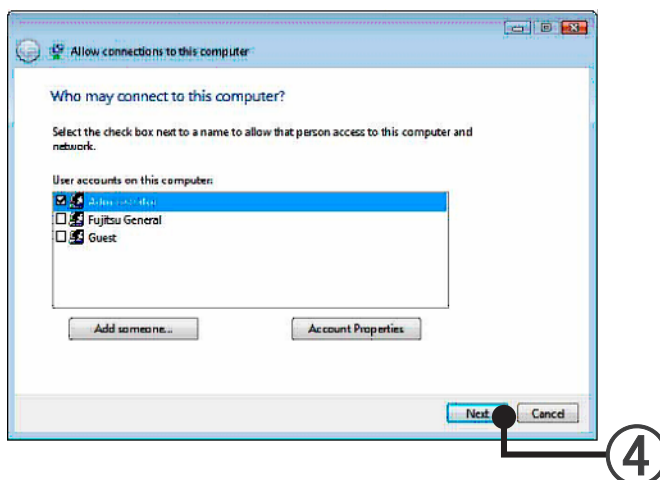

- ④ Click [Next].

- ⑤ Select the model to be used and click [Next].

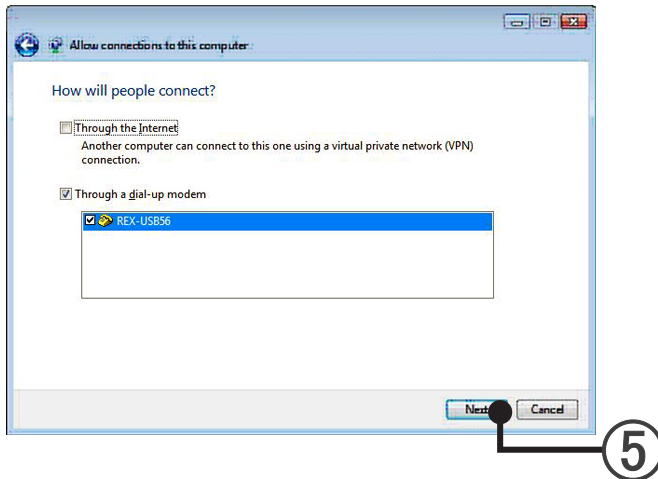

- ⑥ Confirm that “Internet Protocol Version 4 (TCP/IPv4)” is checked. If “Internet Protocol Version 4 (TCP/IPv4)” is not checked, check it.

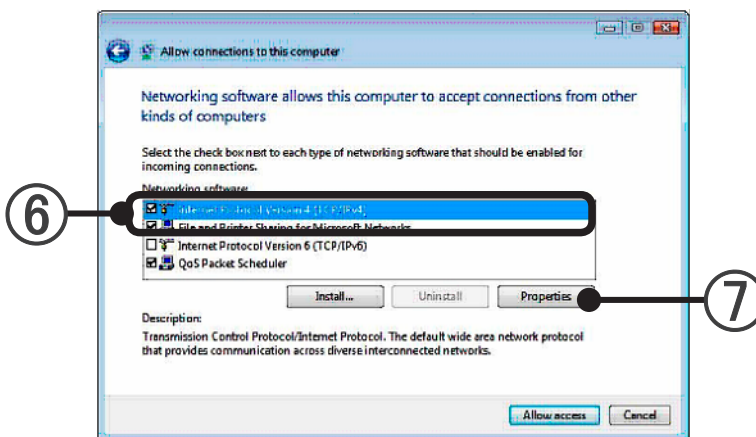

- ⑦ In the Internet Protocol (TCP/IP) selected state, click [Properties].

- ⑧ This screen sets the IP address allocated at incoming connection. Select “Specify TCP/IP address” and sets the “From” and “To” IP addresses serially to match the installation environment in accordance with the network administrator’s instructions.
- Normally IP addresses are specified serially, beginning from 192.168. . , but when connecting the personal computer which performs the setting to another network (for instance, LAN), be sure that the set IP addresses do not duplicate those of a personal computer on the other network.
- For incoming connection, the IP address specified by “From” becomes the IP address of this machine and the IP address specified by “To” is set at the client IP address. The example below shows setting when the local personal computer is made 192. 168. 100. 100 and the client IP address is set to 192. 168. 100. 101.

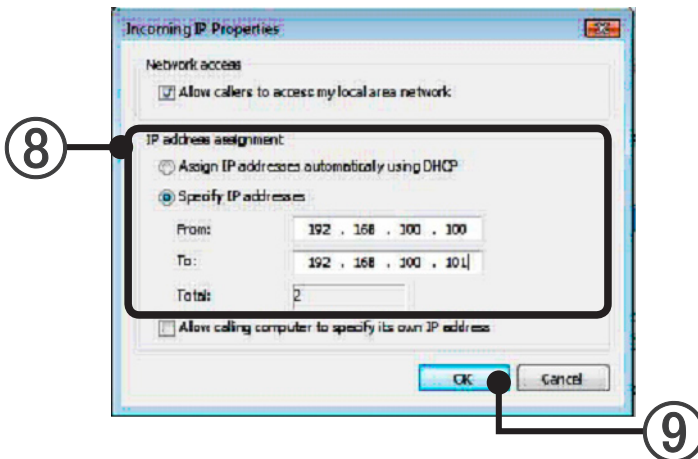

- ⑨ Close the screen by clicking [OK].
Then click [Allow access] in the screen.

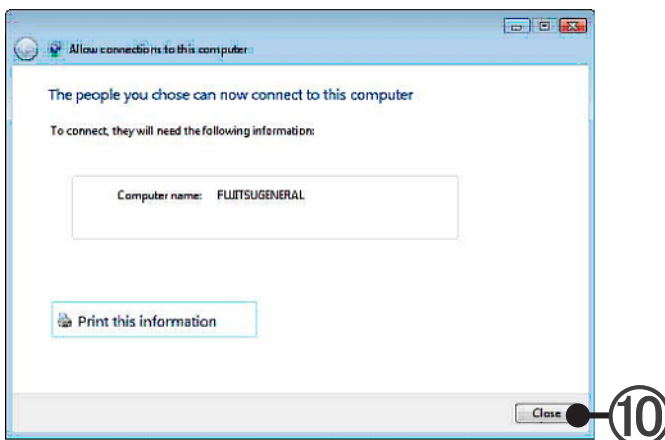

- ⑩ Click [Close].
- Close the “Network Connections” screen.
 - Close the “Network and Sharing center”.

Windows 7

- ① Display the network setting screen by sequentially selecting the menus as follows:
“start”→“Control Panel”→ “Network and Sharing Center”→“Change adaptor settings”
- ② In the Network Connections screen, press “Alt” key. When the menu bar appear on the top, click “File”, then “New Incoming Connection...”

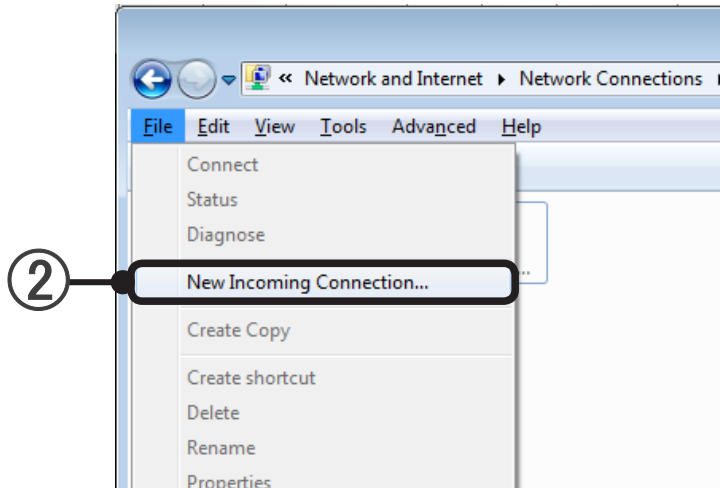

- ③ This screen sets the users who can connect to the computer. The users of the Operating System of the machines are displayed. Check the users allowed to connect from the displayed list. (*1)
Verification is performed by the Operating System at incoming. For connection from the client, the user set here and the password of that user must be input. (*2)
Information

- *1. When creating a new user, click [Add someone...] and create the user from the displayed screen.
- *2. Perform connection from the client from the screen par. 6-2-2 Dial-up setting.

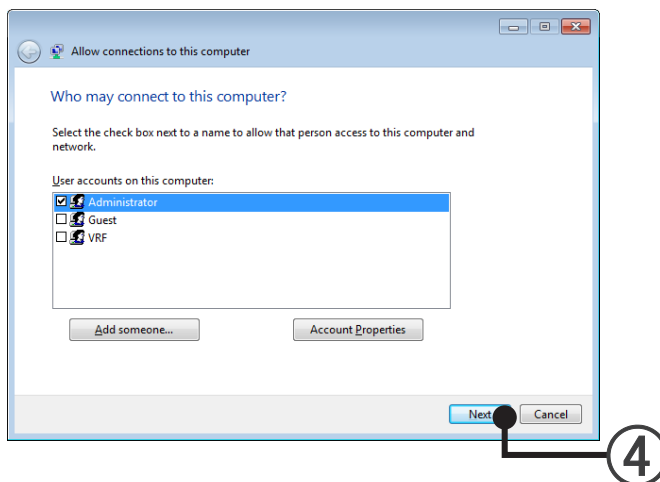

- ④ Click [Next].

- ⑤ Select the modem to be used and click [Next].

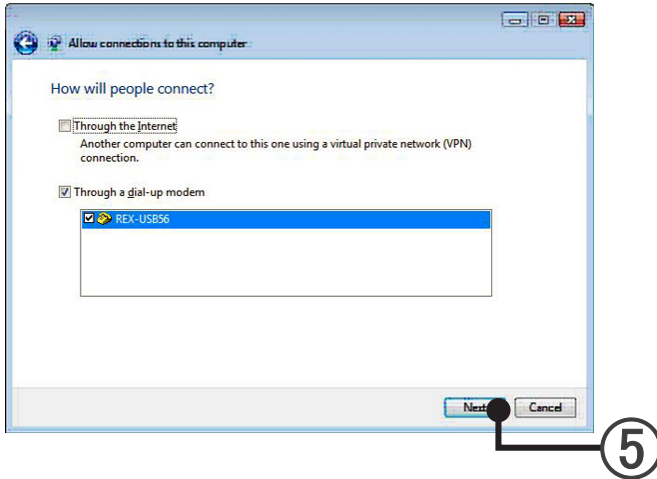

- ⑥ Confirm that "Internet Protocol Version 4 (TCP/IPv4)" is checked. If "Internet Protocol Version 4 (TCP/IPv4)" is not checked, check it.

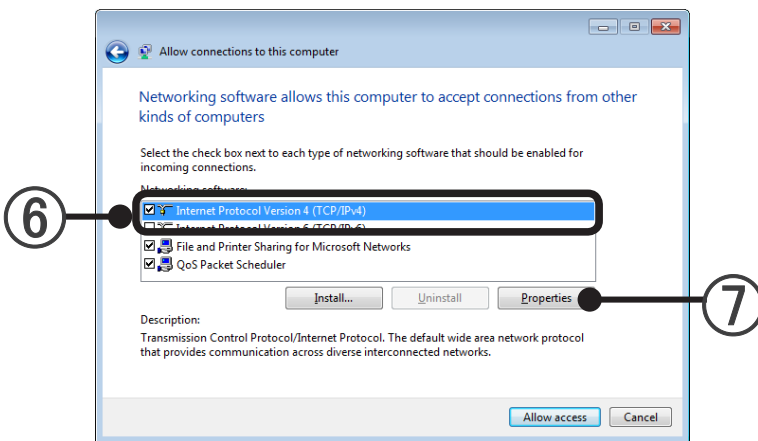

- ⑦ In the Internet Protocol (TCP/IP) selected state, click [Properties].

- ⑧ This screen sets the IP address allocated at incoming connection. Select “Specify TCP/IP address” and sets the “From” and “To” IP addresses serially to match the installation environment in accordance with the network administrator’s instructions.
- Normally IP addresses are specified serially, beginning from 192.168. . , but when connecting the personal computer which performs the setting to another network (for instance, LAN), be sure that the set IP addresses do not duplicate those of a personal computer on the other network.
- For incoming connection, the IP address specified by “From” becomes the IP address of this machine and the IP address specified by “To” is set at the client IP address. The example below shows setting when the local personal computer is made 192. 168. 100. 100 and the client IP address is set to 192. 168. 100. 101.

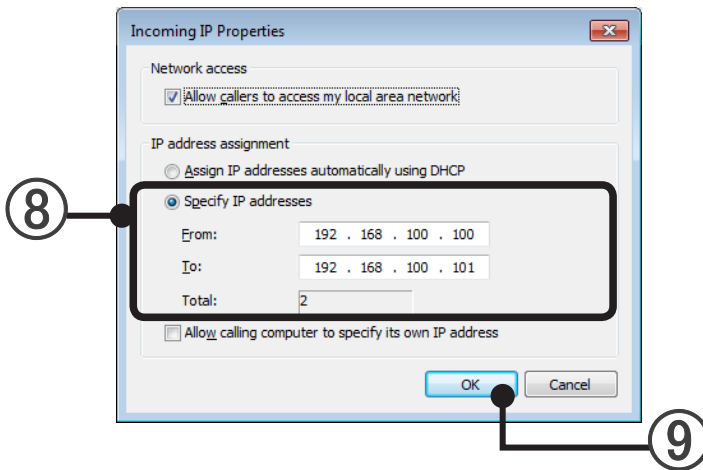

- ⑨ Close the screen by clicking [OK].
Then click [Allow access] in the screen.

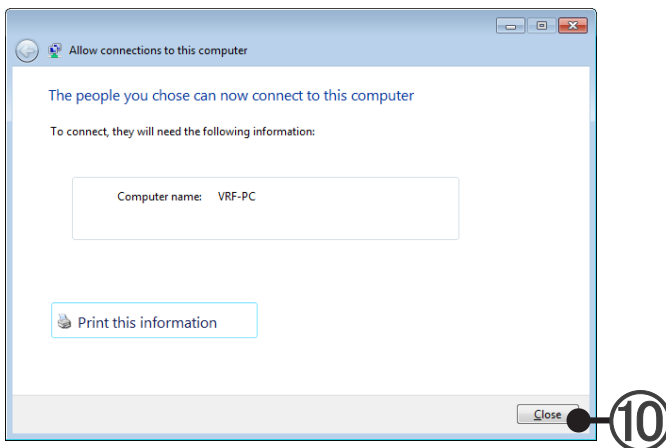

- ⑩ Click [Close].
- Close the “Network Connections” screen.
 - Close the “Network and Sharing center”.

6-2 Network setting (client PC side setting)

The setting contents vary depending on the server and client connection method. Perform setting after confirming the connection method.

The System Controller can be used in the following network connection modes:

1. LAN connection

In this mode, the System Controller can be accessed by multiple terminals on the user's premises connected by intranet.

Required environment : LAN connection environment

- Network Interface

- LAN cable

- Hubs or Routers may become necessary

→ See par. 6-2-1 LAN connection setting

2. Internet connection

Setting is not particularly necessary at the client terminal, but if not authorized by the network administrator, connection may be impossible.

3. Dial-up connection

This mode uses a telephone line to dial-up connect to a server installed on the user's premises.

Required environment: Telephone line, modem

→ See par. 6-2-2 Dial-up connection setting

6-2-1 LAN connection setting

Perform LAN setting to match the usage environment. Contact the network administrator for the IP address, subnet mask, and other settings.

Windows Vista

- ① Display the LAN setting screen by sequentially selecting the menus as follows:

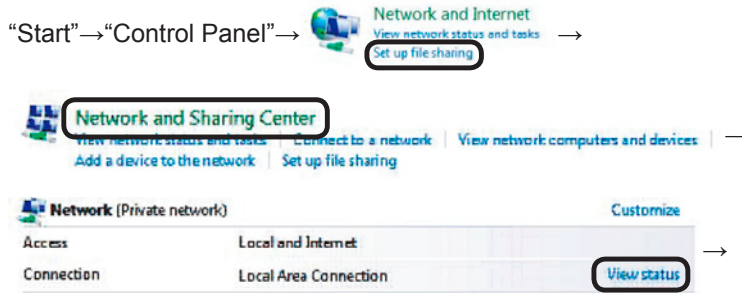

Note

- When the control panel display is Classic View, select the menus in the following order:

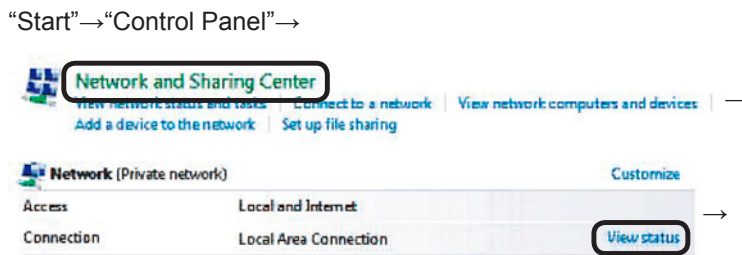

- ② Select by checking "Internet Protocol (TCP/IP)".

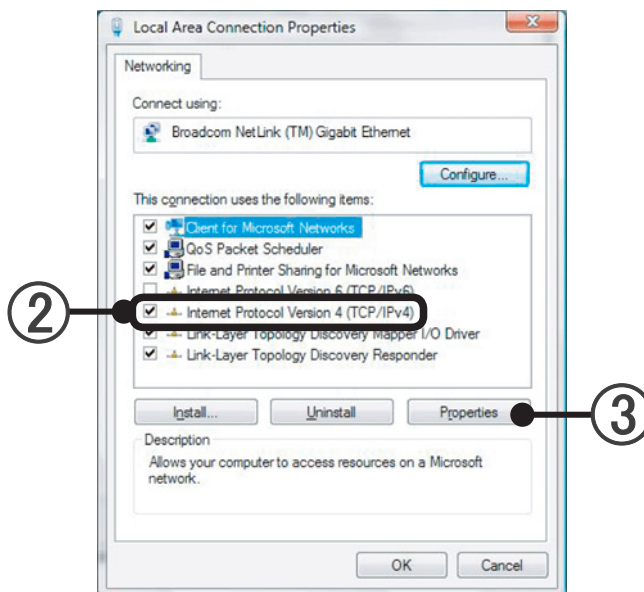

- ③ Click [Properties].

- ④ Select the IP address acquisition/specification method, input IP address to be set, subnet mask, default gateway, and DNS service setting items, which are inputted items of this screen, to match the installation environment in accordance with the network administrator's instructions.

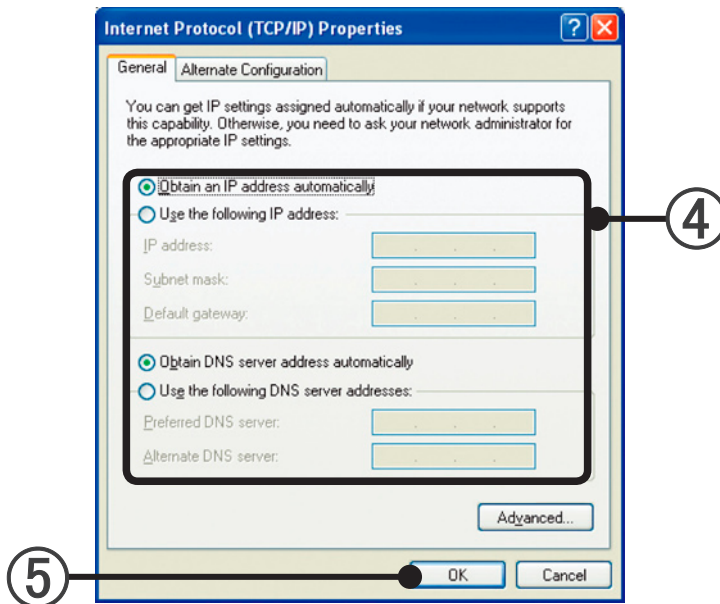

- ⑤ Exit setting by clicking [OK] .

Windows 7

- ① Display the LAN setting screen by sequentially selecting the menus as follows:

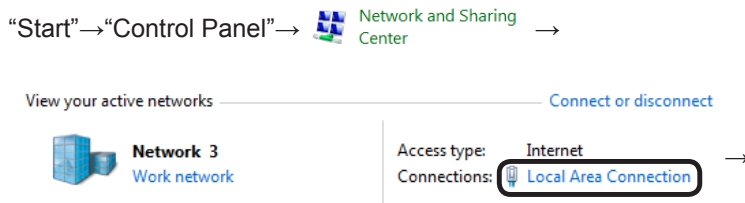

- ② Click [Properties].

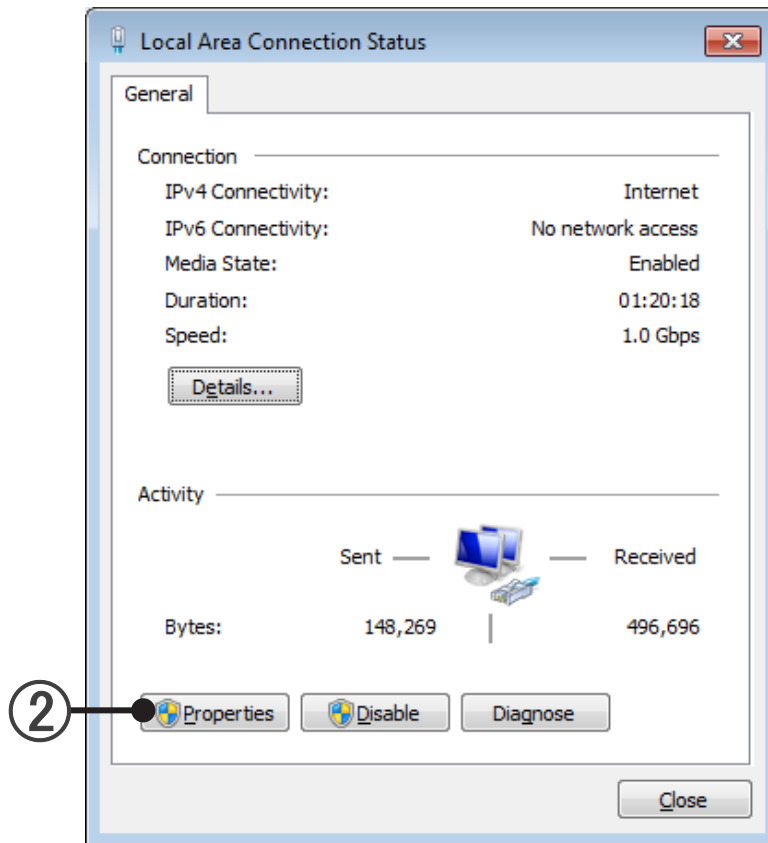

- ③ Select by checking “Internet Protocol (TCP/IP)”.

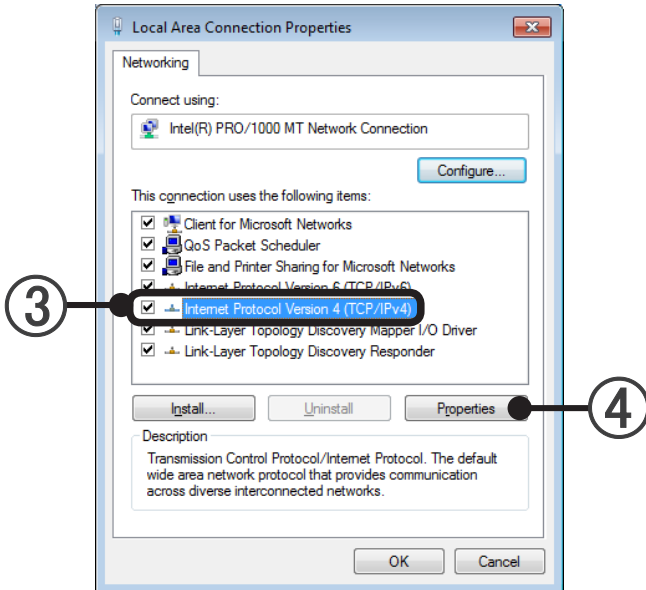

- ④ Click [Properties]

- ⑤ Select the IP address acquisition/specification method, input IP address to be set, subnet mask, default gateway, and DNS service setting items, which are inputted items of this screen, to match the installation environment in accordance with the network administrator's instructions.

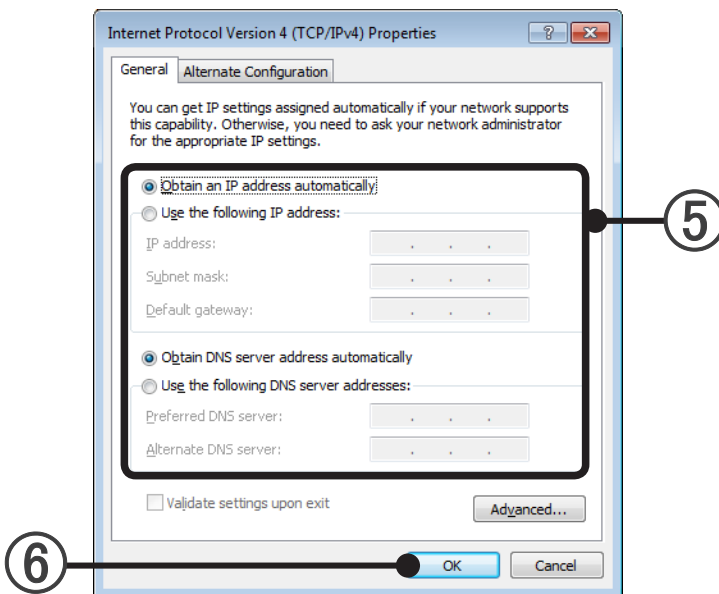

- ⑥ Exit setting by clicking [OK].

6-2-2 Dial-up connection setting

Windows Vista

- ① Display the network setting screen by sequentially selecting the menus as follows:

“Start”→“Control Panel”→  Network and Internet →  Network and Sharing Center →



Note

- When the control panel display is Classic View, select the menus in the following order:

“Start”→“Control Panel”→  Network and Sharing Center →



- ② Select “Connect to a workplace”.

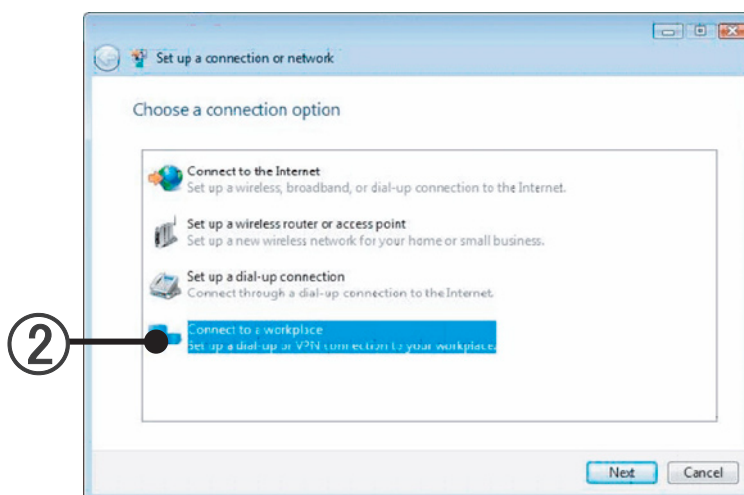

- ③ Select “Dial directly”.

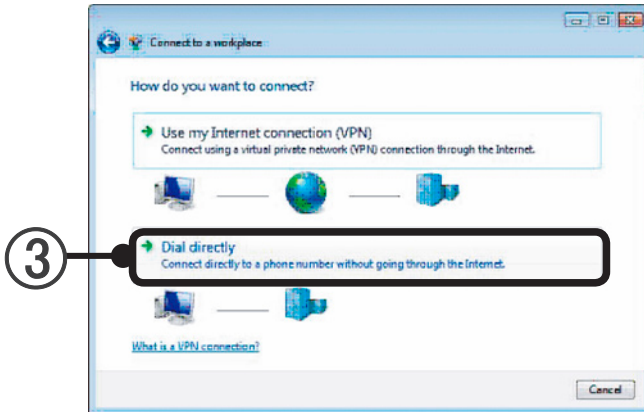

- ④ Type the Telephone number, Destination name (arbitrary), and check on the “Allow other people to use this connection” if there are no special problems. This connection setting can be used by all users of the computer used.

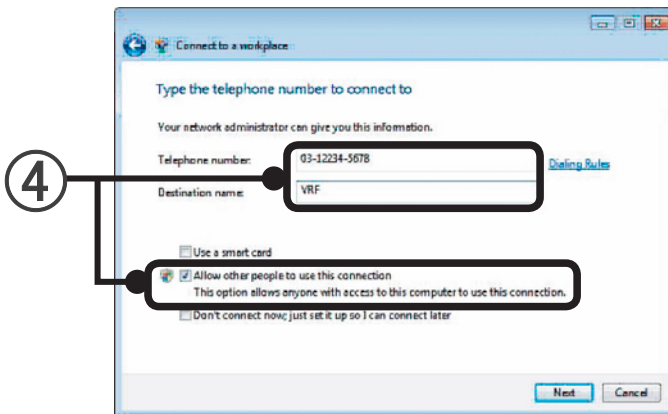

- ⑤ When performing connection, do it from this screen. Here close the screen by clicking [Cancel].

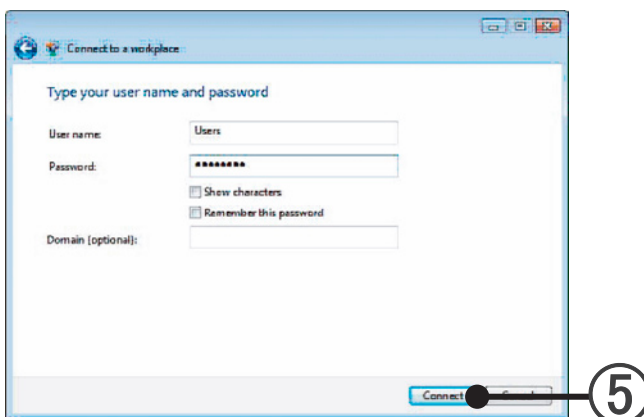

* When performing connection, input the user name/password specified 6-1-1 Incoming setting.

Windows 7

- ① Display the network setting screen by sequentially selecting the menus as follows:

“Start” → “Control Panel” →  Network and Sharing Center →

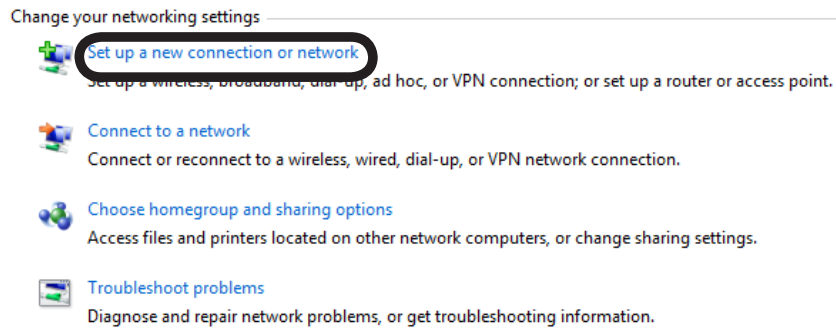

- ② Select “Connect to a workplace”.

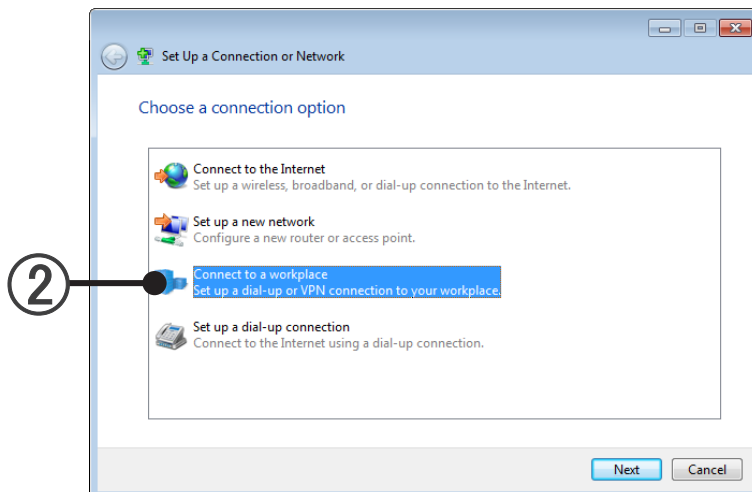

- ③ Select “Dial directly”.

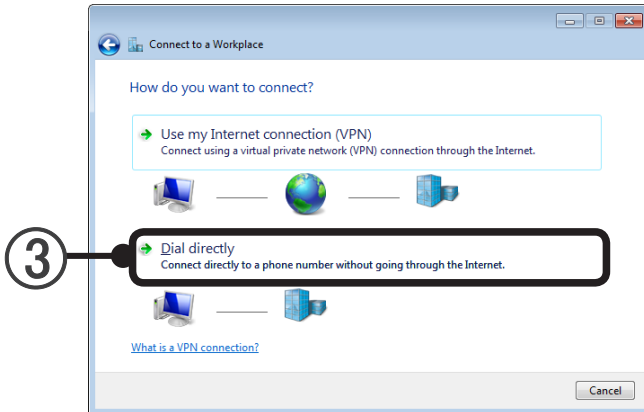

- ④ Type the Telephone number, Destination name (arbitrary), and check on the “Allow other people to use this connection” if there are no special problems. This connection setting can be used by all users of the computer used.

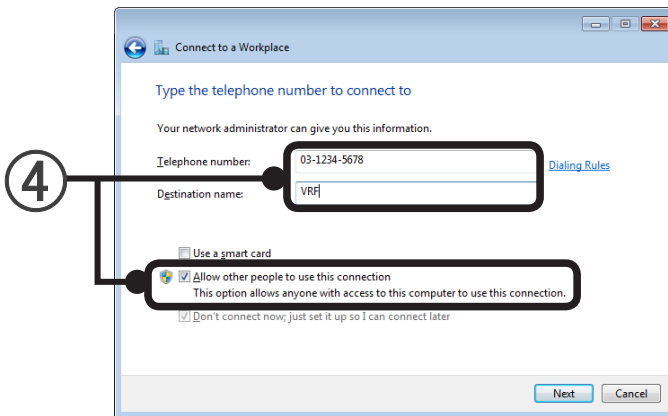

- ⑤ When performing connection, do it from this screen. Here close the screen by clicking [Cancel].

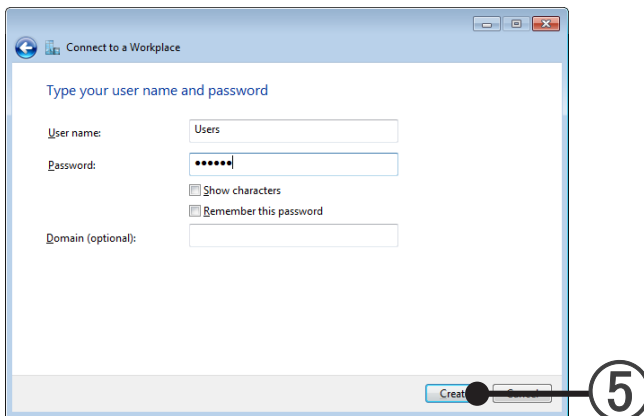

* When performing connection, input the user name/password specified 6-1-1 Incoming setting.

7. Installation (Client PC)

7-1 Installation flow

- Installs the System Controller (client is VRF Explorer only) to the client PC.

Installation flow

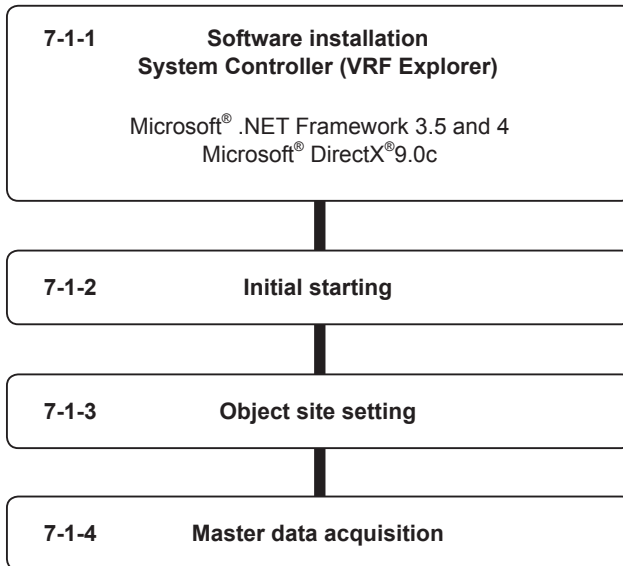

7-1-1 Software install

The following software is installed here.

- Microsoft® .NET Framework 3.5 and 4
- System Controller (VRF Explorer only)
- Microsoft® DirectX® 9.0c

- ① Execute setup.exe in the System Controller folder on the System Controller setup DVD.
- ② Select the same language as that of the Windows® (If you select a different language, characters may not be displayed correctly).

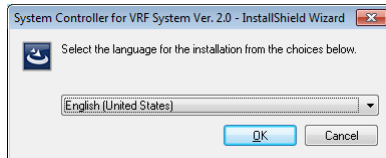

- ③ When "Install" is selected, installation begins.
a When "ReadMeFirst.txt" is selected, ReadMe is displayed.

Note

Be sure to read it for important information.

- b When "Manual" is selected, the manual is displayed.

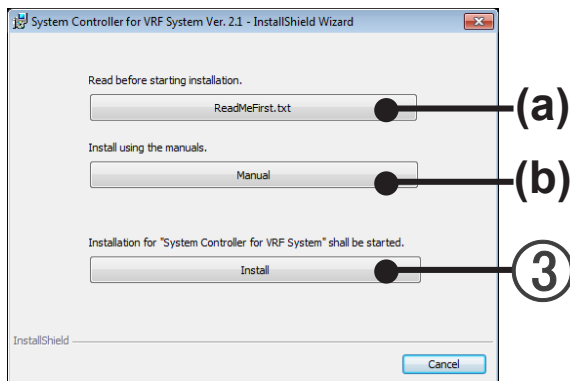

- ④ This screen is displayed. Click the [Next] button.

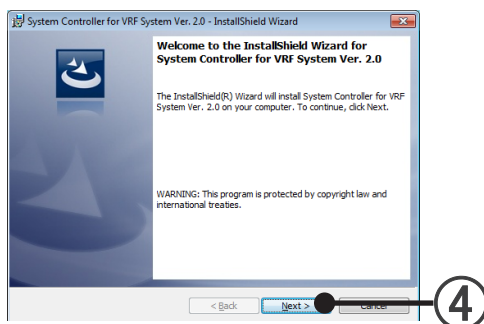

- ⑤ Select Client (VRF Explorer) then press [Next] button.

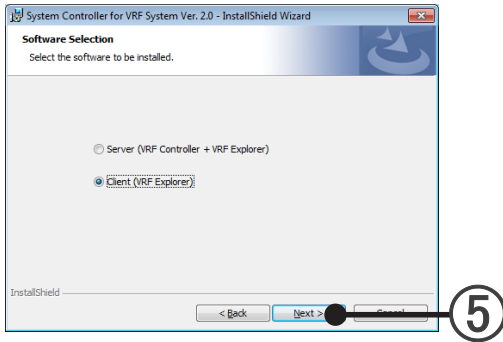

- ⑥ Since the System Controller end user licensing agreement is displayed, confirm the contents. To agree to the terms of the license, check "I accept the terms in the license agreement" and click the [Next] button.

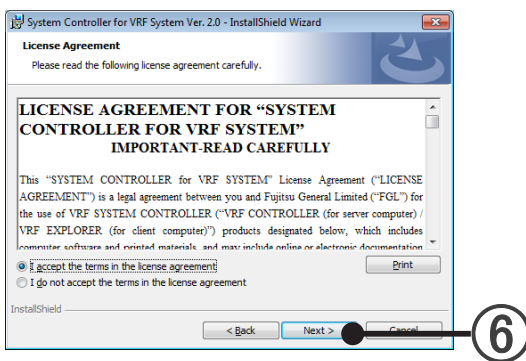

- ⑦ Specify the installation destination folder and click the [Next] button.

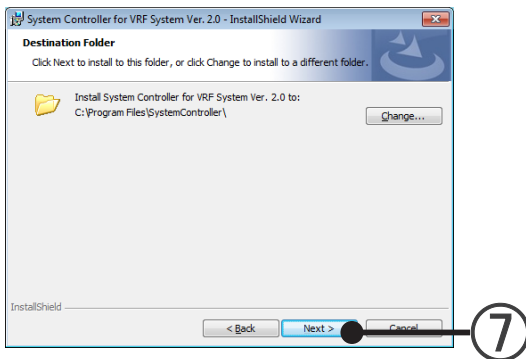

- ⑧ If the installation setting contents are correct, click the [Install] button.

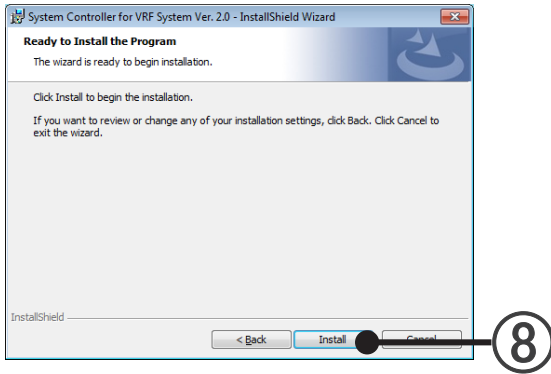

Installation starts.

The necessary drivers are also installed at the same time.

“Microsoft® DirectX®9.0c” is also installed automatically.

When following error appears during the installation of the System Controller; “Internal error 25259.

DirectX -9: An internal error occurred.” execute the following program and install DirectX.

Execute DXSETUP.exe in the DirectX9c folder on the system controller setup DVD.

- ⑨ After copying of all the files is complete, this screen is displayed.
Click the [Finish] button.

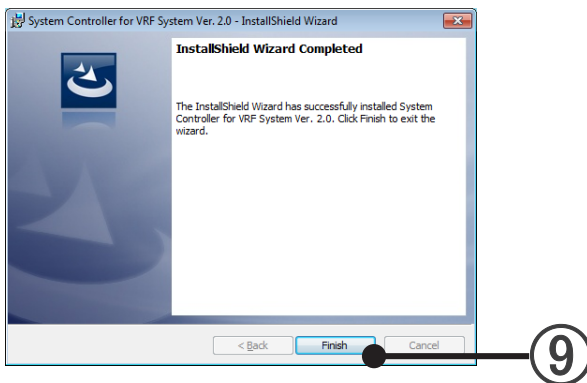

This completes installation of the System Controller for VRF System Client (VRF Explorer).
Next, initially start and make the various settings. → See par. 7-1-2 Initial starting

7-1-2 Initial starting

- ① Start from Windows® start.
Select “Start” → “All programs” → “System Controller for VRF System” → “VRF Explorer”

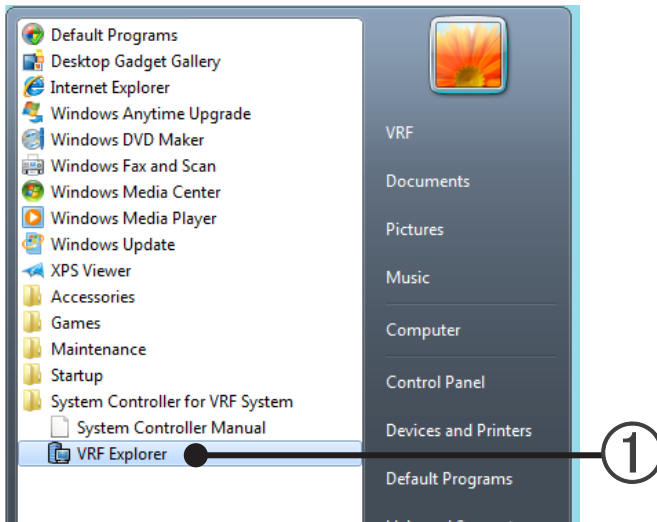

- ② System Controller starts.



Continued at par. 7-1-3 object site setting.

7-1-3 Object site setting

Set the site connected from the VRF Explorer.

- ① Since "Site Navigator" is displayed, click [Setup].

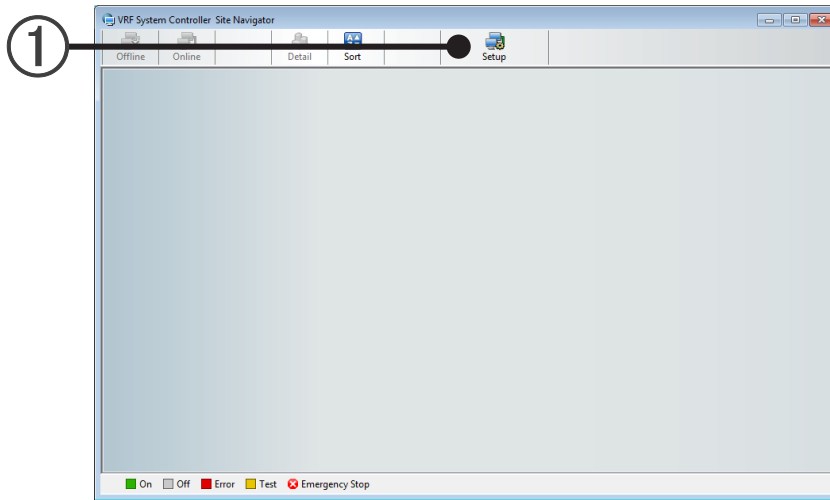

- ② Since "Site Setting" is displayed, enter the site name at "Site Name".

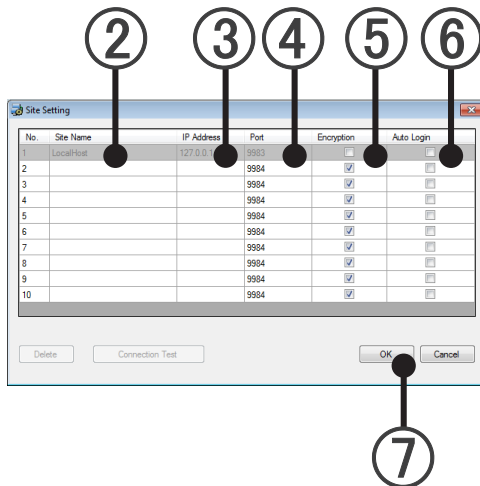

- ③ Enter the IP address of the server PC (VRF Controller) to be connected.
For LAN connection, enter the intranet IP address.
For internet connection, enter the global IP address of the server.
For dial-up connection, enter the IP address of the server PC set at par. 6-1-1 Incoming setting.
- ④ The Port No. to be set is displayed. → See par.13-3 Port Setting
- ⑤ Check Encryption and match with the setting of the connection destination VRF Controller.
→ See par.13-2 Security setting

Checked: Encrypt
Unchecked: Do not encrypt
- ⑥ Login automatically without entering password.
This can be checked at login screen.
- ⑦ Click [OK].

- ⑧ This registered 1 connection destination site.
Select a displayed offline state “Site” icon.

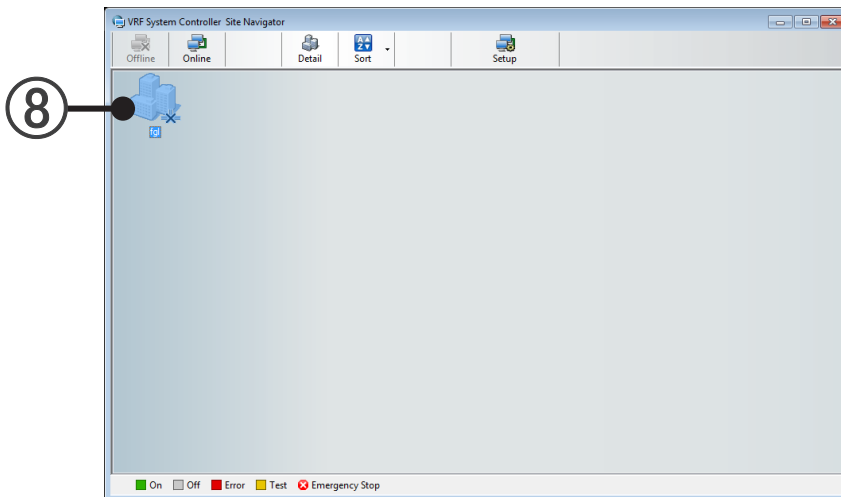

- ⑨ Click [Online] (Site icon can also be double clicked.)

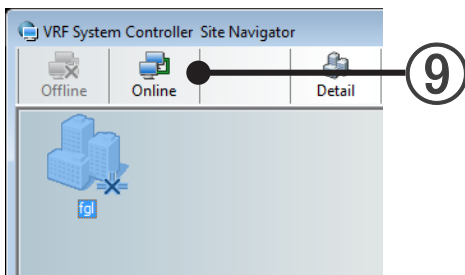

* When “Failed to correct” is displayed, see “Not connected from client PC to server PC” in the “25-1 Trouble-shooting”.

- ⑩ Since the login screen is displayed, enter the allocated Login ID and Password.

* When the login ID and Password are not known, please contact the administrator of the connection destination VRF Controller.

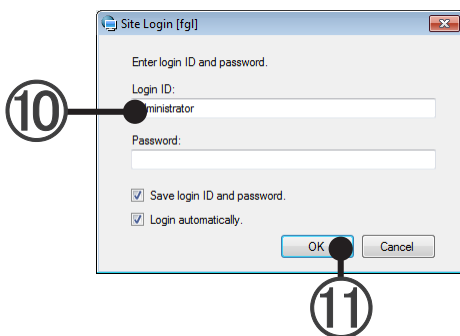

- ⑪ Click [OK].

Since it is the first connection to the site, the “Master data acquisition” screen is displayed.

Continued at par 7-1-4 Master data acquisition.

7-1-4 Master data acquisition

Acquire the newest master data from the server.

- ① When a layout image is set, the checkbox of (b) is enabled.
When acquiring the layout image also, check the checkbox.
Click the (a) [OK] button and acquire the master data.

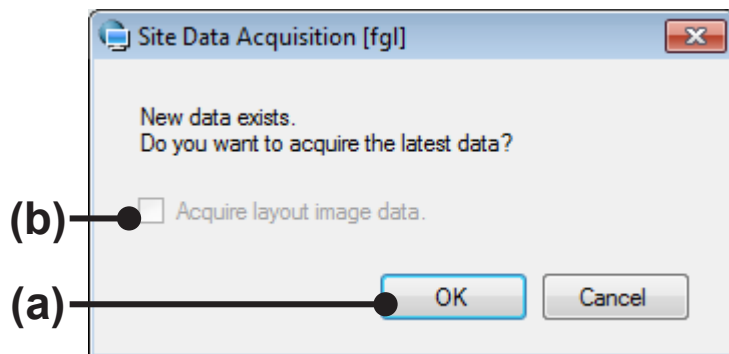

- ② The "Site" icon enters the connected state.

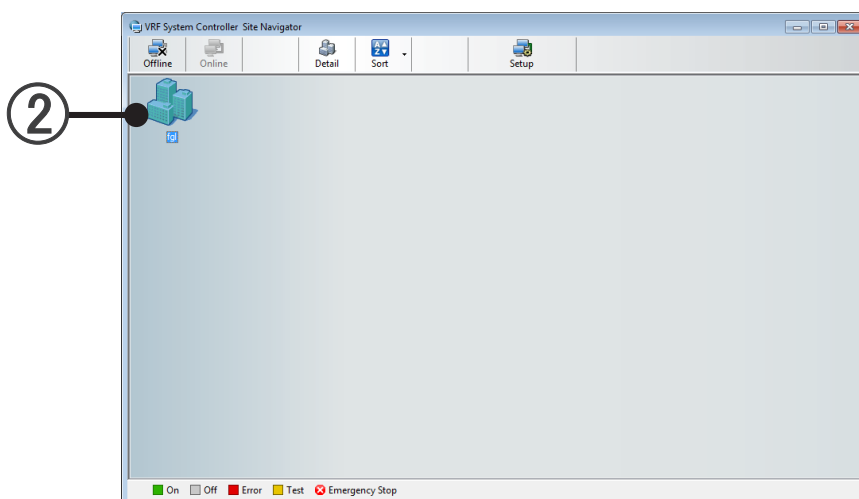

This allows use of the VRF Explorer.

For the VRF Explorer operation method, see VRF Explorer Operation section.

7-2 Uninstall and version upgrade

For uninstallation and version upgrade in the Client PC, follow the procedures shown below.

Note

For upgrade, when the method of upgrading a version supplied with a new version of the System Controller is announced, give it priority.

When the version upgrading method is not supplied with the new version System Controller, refer to the procedure described in par. 7-1-1 Software install.

Flowchart for uninstallation and upgrade

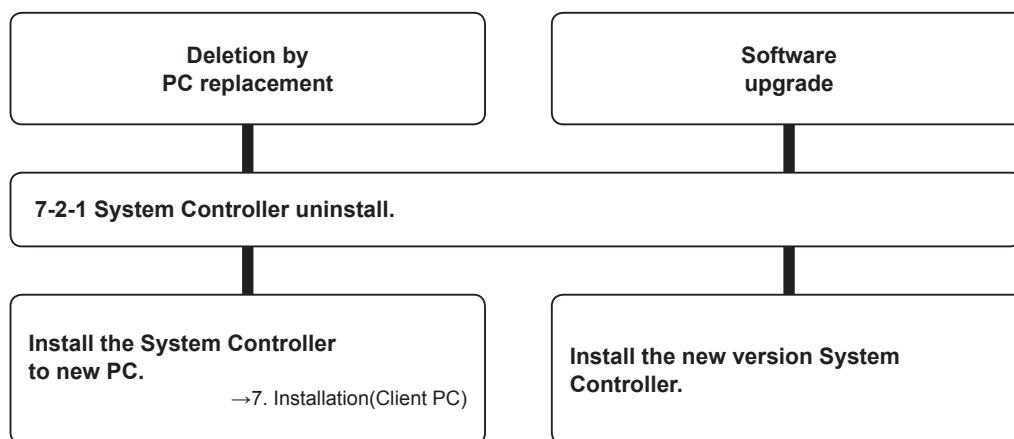

7-2-1 System Controller uninstall

Windows Vista

- 1 Display "Start" → "Control Panel" → "Add or Remove Programs"

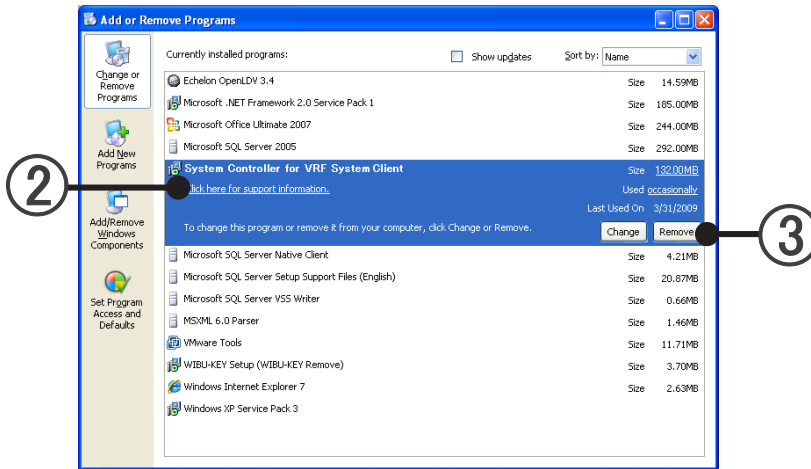

- 2 Select "System Controller for VRF System".
- 3 Click the [Remove] button.

Windows 7

- 1 Display "Start" → "Control Panel" → "Programs and Features"

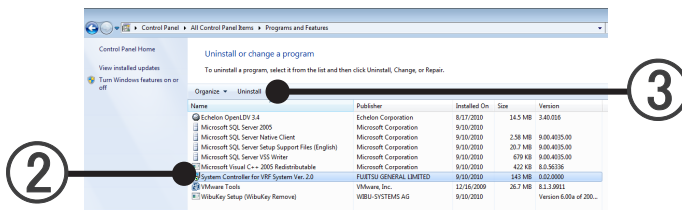

- 2 Select "System Controller for VRF System".
- 3 Click the [Uninstall] button.
- 4 When the [Yes] button is clicked, uninstallation begins.

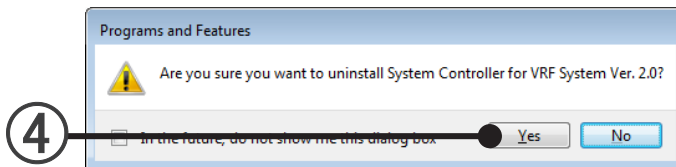

- ⑤ When the screen displaying the uninstallation process closes, uninstallation is complete.
- ⑥ Close the “Programs and Features” screen by clicking the [×] at the top right-hand corner of the screen.
 - * A folder named “SystemController” remains in the folder designated as the System Controller installation folder at installation even though uninstallation is performed
There is no problem even if this folder remains, but it doesn’t matter even if the folder is deleted.

Note

When installing the System Controller, “Microsoft®.NET Framework 3.5” and “Microsoft®.NET Framework 4” may be installed at the same time.

Since “Microsoft®.NET Framework 3.5” and “Microsoft®.NET Framework 4” may also be used by other programs, if it is uninstalled, the other programs may not run properly.

If not inconvenient, do not uninstall “Microsoft®.NET Framework 3.5”, and “Microsoft®.NET Framework 4” and let it remain as is.

Settings

8. Basic Settings
9. Electricity Charge Apportionment Setting
10. Error E-mail Notification Setting
11. User Environment Setting

8. Basic Settings

The basic settings necessary before use in the server PC are made. They are also made when the settings are updated due to equipment and tenant changes.

When starting the system for the start time after installation, make the settings in accordance with the flow described below. At the 2nd and subsequent starting, make the necessary settings in accordance with par. 8-1 and subsequent paragraphs, as required.

Settings flow at initial starting

When initially starting the system, make the settings in accordance with this flow. The ★ symbol indicates essential items.

The screen display method is described at the beginning of each setting item, but this is not related to the setting flow at initial starting.

The screen is switched to the necessary screen automatically by clicking the [Next] button on each setting screen.

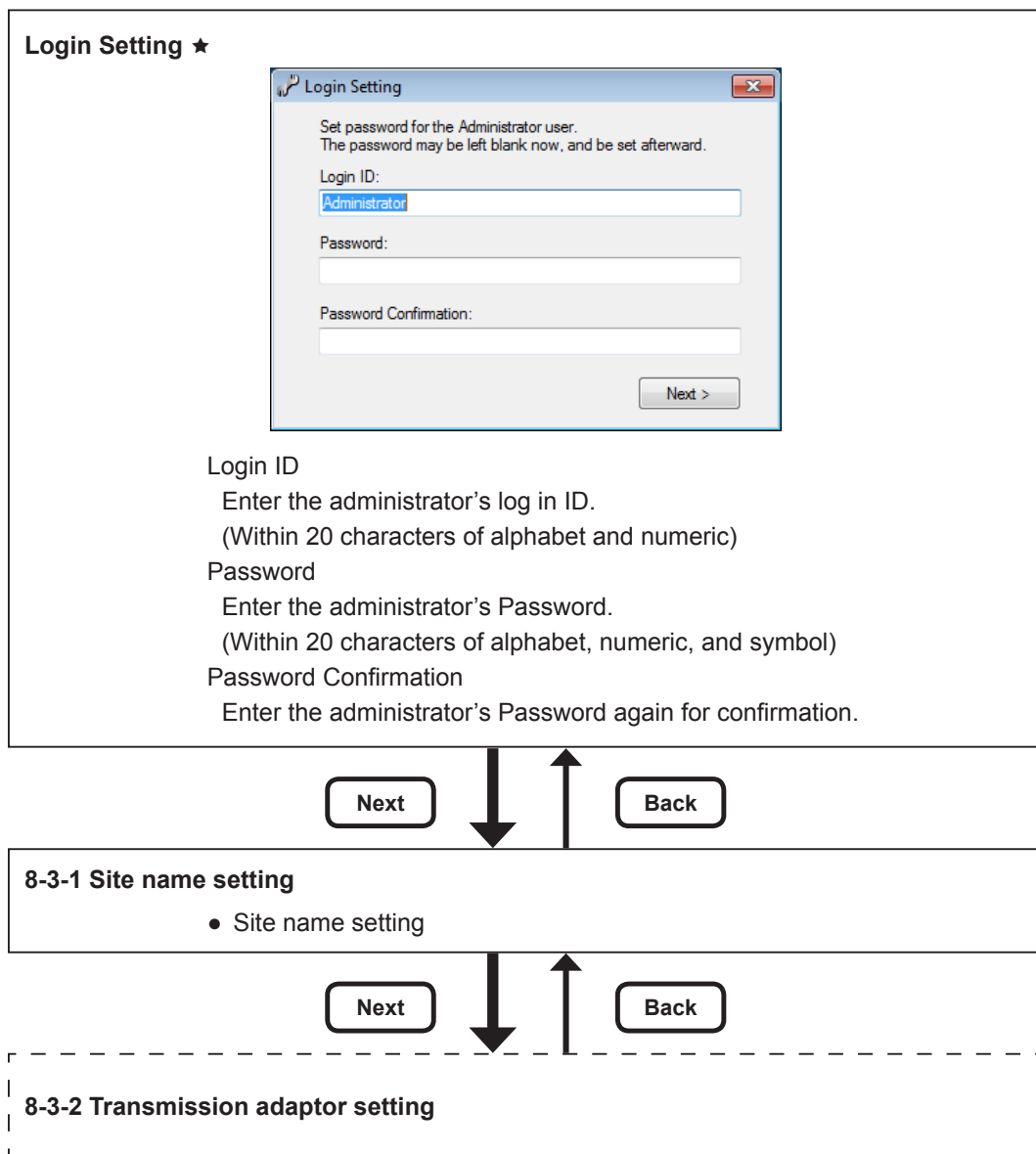

(Next page)

(Former page)

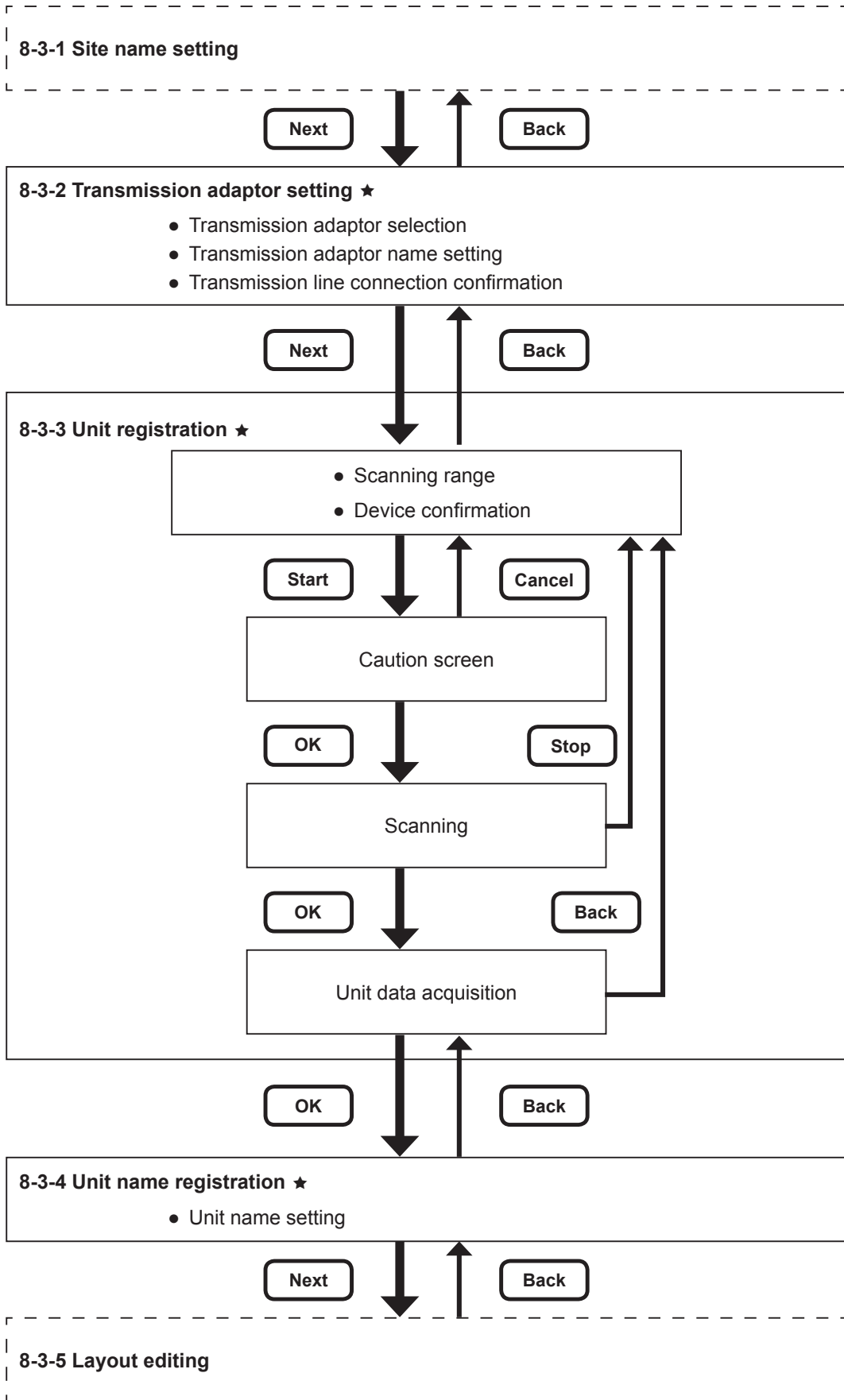

(Next page)

(Former page)

8-3-4 Unit name registration

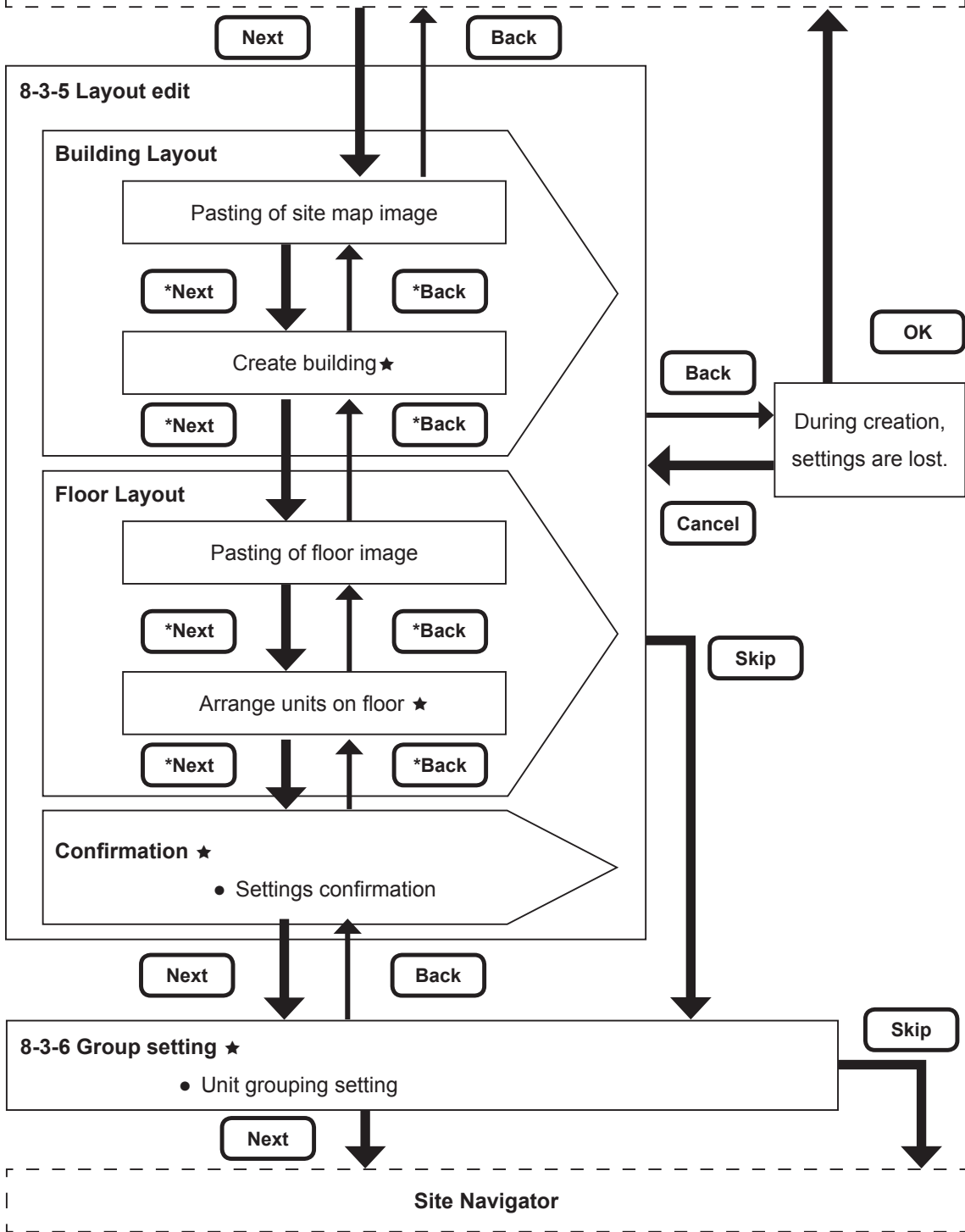

Note

- * When editing the layout, use the [Next] and [Back] buttons at the top right-hand side of the screen. In layout editing, free movement is possible with these buttons.

When the [Back] button at the bottom right-hand side of the screen is clicked, the confirmation screen appears. It shows whether data being generated is discarded and a return to “8-3-4 Unit name registration” or not.

(Return to “8-3-4 Unit name registration” can be stopped by clicking the [Cancel] button on the confirmation screen.)

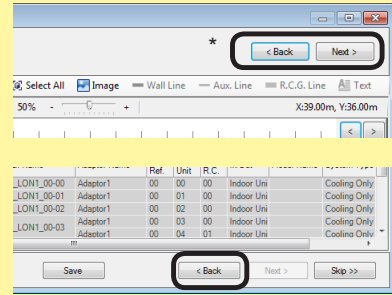

8-1 User management settings

Displays the list of the user to be registered.

New user registration and user registered contents change and deletion can be performed.

① Select main screen menu → "Setting" → "User Setting".

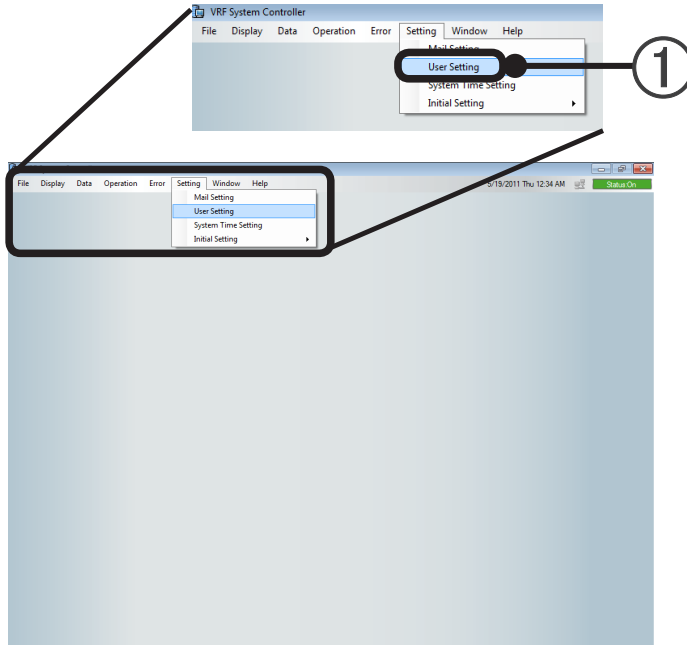

The "User Setting" screen opens. Advance to par. 8-1-1 "User Setting" screen.

8-1-1 User Setting screen

Description of screen

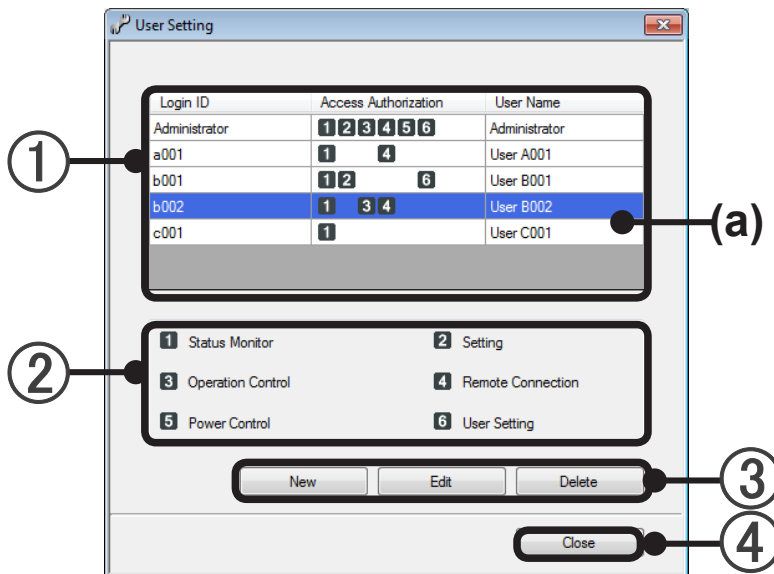

- ① User list: Displays the log in ID, access authorization, and user name of the registered users.
 - (a) The selected users are displayed against a blue background.
- ② Access Authorization list: Displays the access authorization setting item of ①.

	Item	Operable contents
1	Status Monitor	Site display, Building 3D display, Floor display, List display, Error notification, Operation history, Error history, User environment setting
2	Setting	Site name setting*, Unit registration*, Unit name registration*, Layout editing, Group setting, Transmission adaptor setting*, Error e-mail notification
3	Operation Control	Operation control, Memory operation, Schedule operation
4	Remote Connection	Remote connection
5	Power Control	Electricity charge apportionment setting, Apportionment calculation execution, Bill creation , Energy saving
6	User Setting	User management setting (these settings)

* The setting is possible only at a local connection.

Note

The administrator can perform all the operations shown above.
Only the administrator can operate the VRF Controller.

- ③ [New]: Registers new users.
When this button is clicked, the User Registration screen opens. (See par. 8-1-2.)
- [Edit]: The access authorization, user name, and password of the selected user can be changed. When this button is clicked, the User Registration screen opens. (See par. 8-1-3.)
- [Delete]: Deletes a registered user.
(The Administrator cannot be deleted.)
- ④ [Close]: Closes the User Setting screen.

8-1-2 New user registration

Creates a new user who can log in to the system controller.

To display this screen, click the ③ [New] button on the par. 8-1-1 User Setting screen.

The screenshot shows a 'User Registration' dialog box with the following elements and callouts:

- ①: Login ID* text box
- ②: Access Authorization section containing checkboxes for Status Monitor, Setting, Operation Control, Remote Connection, Power Control, and User Setting.
- ③: User Name text box
- ④: Password text box
- ⑤: Password Confirmation text box
- ⑥: OK, Cancel, and Apply buttons at the bottom.

- ① Enter the Login ID. [Essential] (Cannot be changed after setting is complete.)
(Used when logging in.) (Within 20 characters of alphabet and numeric)
- ② Select the function allowed by [Access Authorization]. [Essential]
Since Status Monitor is always valid, uncheck the checkbox.
- ③ Enter User Name. (Within 20 characters of alphabet, numeric, and symbol)
- ④ Enter Password. (Used when logging in.)
(Within 20 characters of alphabet, numeric, and symbol)
- ⑤ Re-enter and confirm Password.
- ⑥ [OK]: Registers the settings and ends registration.
[Cancel]: Ends registration without registering the settings.
(When [Apply] was performed during setting work, the contents cannot be canceled by [Cancel].)
[Apply]: Registers the contents with the input screen remaining open.

8-1-3 Registered user editing

Edits registered users of the system controller.

To display this screen, click the ③ [Edit] button on the par. 8-1-1 User Setting screen.

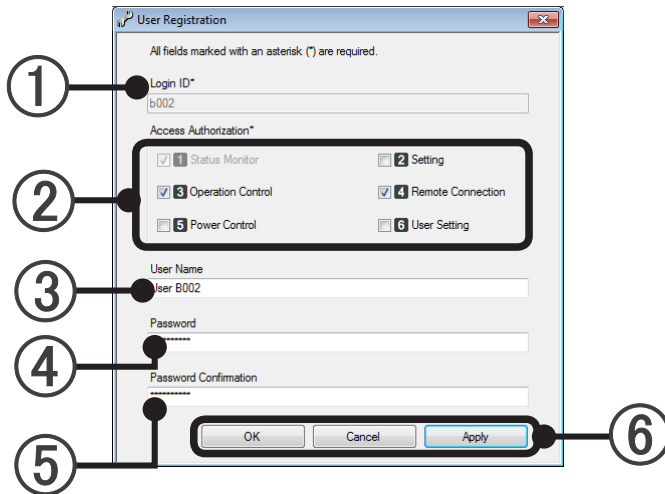

- ① Login ID is displayed. (Cannot be changed.) (Used when logging in.)
- ② Select the function allowed by [Access Authorization]. [Essential] Status Monitor is always valid, and can not be unchecked.
- ③ Enter User Name. (Within 20 characters of alphabet, numeric, and symbol)
- ④ Enter password. (Used when logging in.) (Within 20 characters of alphabet, numeric, and symbol)
- ⑤ Re-enter and confirm Password.
- ⑥ [OK]: Registers the settings and ends registration.
[Cancel]: Ends registration without registering the settings. (When [Apply] was performed during setting work, the contents cannot be canceled by [Cancel].)
[Apply]: Registers the contents with the input screen remaining open.

Note

Registered Login ID cannot be changed.
If the change was performed for a user being logged in, the change is reflected from the next log in.

8-2 System Time Settings

Set the time for the controllers connected to the VRF network. (V-II only)

- ① Select the item to be set from main screen menu → “Setting” → “System Time Setting”.

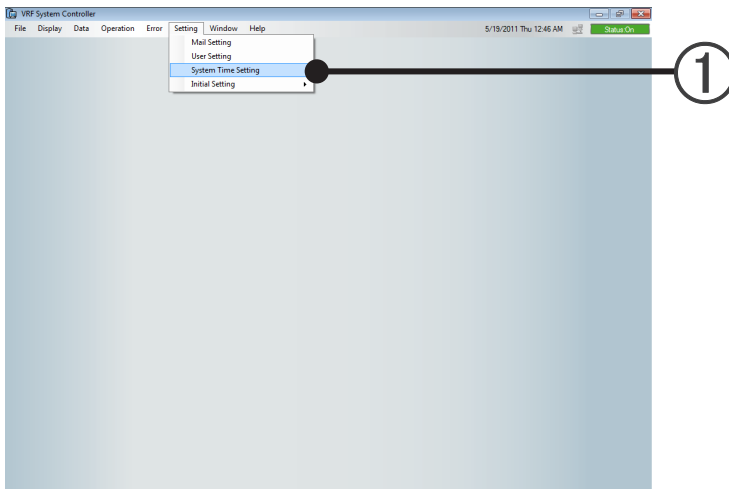

8-2-1 System Time Setting screen

Description of screen

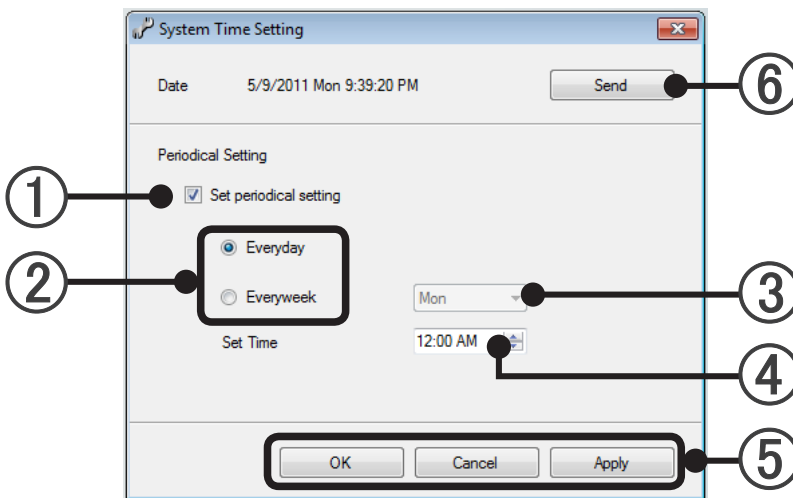

Periodical setting

Periodically set the time at specified day of every day or every week.

- ① [Set periodical setting] Periodical setting is enabled by checking.
- ② [Everyday, Everyweek] Select everyday or everyweek time setting.
- ③ Select the day of week periodical setting is to be performed. Setting is possible only when Everyday was selected at step ②.
- ④ Specify the time periodical setting is to be performed.

- ⑤ When the [OK] button is clicked, the set contents are reflected and System Time Setting ends.
[Cancel]: If there is data being edited, discards the data being edited and ends setting.
[Apply]: Saves the set contents without ending setting.
(System Time Setting screen is displayed as it is.)

Manual setting

Set the time to the current time.

(Manual setting cannot be performed from remote PC.)

- ⑥ [Send] Displays a send confirmation message.

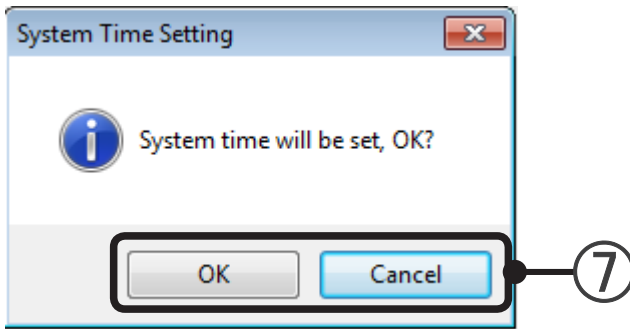

- ⑦ [OK]: When clicked, sends the current time to the VRF network.
[Cancel]: Returns to the System Time Setting screen without sending time data.

8-3 Initial setting

Makes any settings and changes necessary before operation.

- ① Select the item to be set from main screen menu → “Setting” → “Initial Setting”.

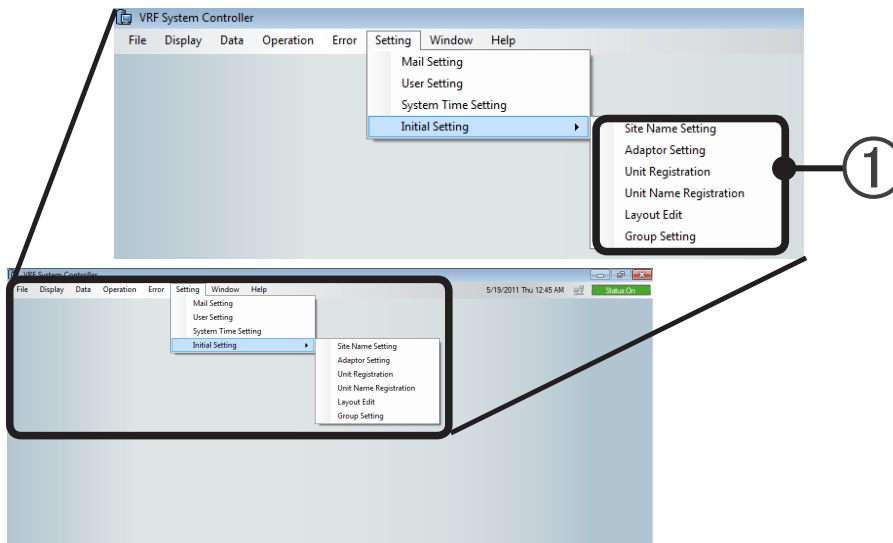

Item	Contents
Site Name Setting	The site name can be set and changed. (For details, see par. 8-3-1.)
Adaptor Setting	The transmission adaptor (U10 USB Network Interface) name can be changed and the connection state can be confirmed. (For details, see par. 8-3-2.)
Unit Registration	The connection state of each unit can be confirmed by network scan (For details, see par. 8-3-3.) Note) During scanning at secure reg. unit operation is stopped.
Unit Name Registration	R/C group and outdoor unit group name can be set and changed. (For details, see par.8-3-4.)
Layout Edit	Site, building, and floor layout display can be edited. (For details, see par. 8-3-5.)
Group Setting	An arbitrary group can be set by combining R/C group and outdoor group. (Up to 3 floors) Batched control and data can be obtained by setting a group. Group setting by different refrigerant systems and duplicate setting at multiple groups are also possible. (For details, see par. 8-3-6.)

8-3-1 Site name setting

Sets and changes the site name.

To display this screen, select main screen menu → “Setting” → “Initial Setting” → “Site name setting”.

Description of screen

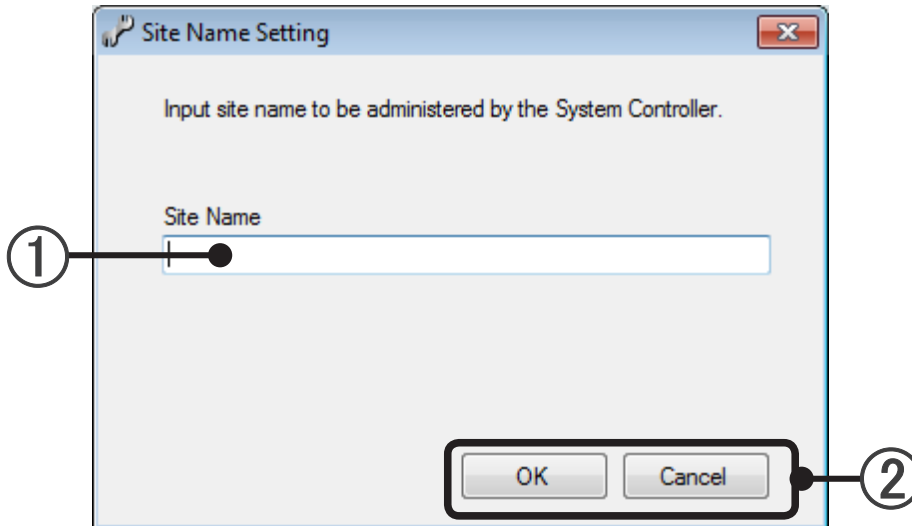

- ① Enter the site name. (Within 20 characters of alphabet, numeric, and symbol)

Note

The Site Name entered at ① is the name of a site directly controlled from the VRF Controller. It does not necessarily have to match the “Site Name” on the Site Navigator when connecting from the VRF Explorer.

- ② [OK]: Saves the settings and ends setting work. (At initial starting, [Back]: Returns to log in setting)
[Cancel]: Ends setting without saving the settings. (At initial starting, [Next]: Advances to Transmission adaptor setting)

To perform setting at initial starting, advance to par. 8-3-2 Transmission adaptor setting by clicking the [Next] button.

8-3-2 Transmission adaptor setting

Sets the name and confirms the connection state of the Transmission adaptor (U10 USB Network Interface) that connects the VRF Controller.

To display this screen, select main screen menu → “Setting” → “Initial Setting” → “Adaptor setting”.

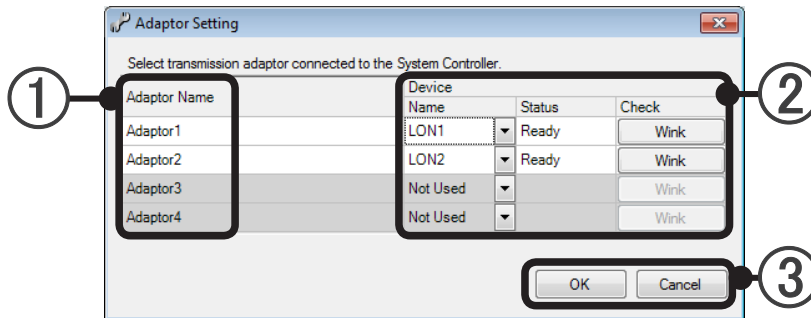

- ① The adaptor name can be set for easy identification by the user. Click the adaptor name you want to set and enter the text. (Default name: “AdaptorX”)

Up to 20 characters (alphabet, numeric, and symbol) can be set. The adaptor name cannot be duplicated. Only the connected adaptor can be set.

- ② Usable device setting and confirmation are possible.

Name	A usable devices list (LONx) or “Not Used” can be pulled down and selected.	
Status	Displays the device status.	
	Ready	The specified adaptor can be used.
	Busy	The specified adaptor is being used by another system.
	Error	The specified adaptor cannot be used.
	(Blank)	Not displayed when an adaptor is not connected.
Check	When the [Wink] button is clicked, the SVC lamp of the specified device lights (for approx. 2 second) and you can confirm which Transmission line the adaptor is connected to. (Only when the device status is Ready)	

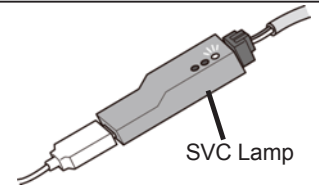

- ③ [OK]: Saves the settings and ends setting work. (At initial starting, [Back]: Returns to site name setting)
 [Cancel]: Ends setting work without saving the settings. (At initial starting, [Next]: Advances to unit registration)

Note

Adaptor Name is a name which can be arbitrarily set so that the user can easily identify connection of the Transmission adaptor (U10 USB Network Interface). (Default name: “AdaptorX”)

“Device Name” is a name automatically allocated to the network when a “Transmission adaptor” (U10 USB Network Interface) is connected. (User may select the LONx number)

It is necessary that set Transmission adaptor respectively because of the S/V series and V-II/J-II/VR-II series can not be connected to the same communication line.

To perform setting at initial starting, advance to par. 8-3-3 Unit registration by clicking the [Next] button.

If it is changed to “Not Used”, all data on the connected adaptor will be deleted.

8-3-3 Unit registration

Scans by the network and detects and registers usable R/C groups and outdoor units.
 The units registered by scanning are managed by system controller.
 To display this screen, select main screen menu → “Setting” → “Initial Setting” → “Unit Registration”.

Description of screen

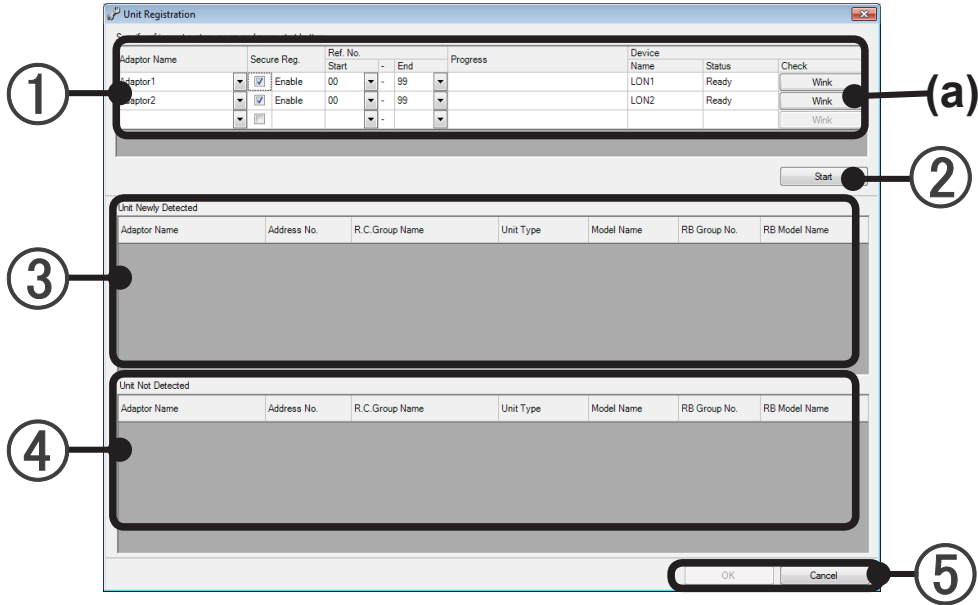

Note

When the PC system time is turned back by time change operation and the start date of contract or block for electricity charge apportionment is at some future date, the contract and block are deleted at the completion of scanning.

① VRF network list: Sets the scan targets.

Adaptor Name	Selects the name of the adaptor which is to perform scanning. (Name set at par. 8-3-2 Transmission adaptor setting.) Unit registration is necessary for each adaptor. When an adaptor is set at a blank line, a blank line is added below it. The same adaptor can be set on multiple lines and different refrigerant system can also be specified.	
Secure Reg.	Specifies by checkbox whether or not secure registration is to be performed when scanning Checked: Secure registration (Recommended) Not checked: No secure registration When scanning is performed at secure registration, operation of the units is stopped. When you do not want to stop operation, uncheck the checkbox. See par. 26-1 No.6.	
Ref. No.	Start	When partially scanning, specify the start number of the refrigerant system by pull-down menu or key input. See par.26-1 No.10.
	End	When partially scanning, specify the end number of the refrigerant system by pull-down menu or key input.
Device	Name	Displays the name of the device used by the relevant network.
	Status	Displays the status of the device used by the relevant network. Normal: "Ready" Abnormal: "Error" Not connected: "Blank"
	Check	When the (a) [Wink] button is clicked, the SVC lamp of the Transmission adaptor used by the relevant network lights (for approx. 2 second) and connection of the selected adaptor can be identified. (Effective only when the status of the Transmission adaptor is normal.)

② [Start] button:

Starts scanning. (Disabled when there is no scanning target.)

Note) All systems connected to 1 Transmission adaptor (U10 USB Network Interface) are stopped during scanning at secure reg.

The time required by scanning differs with the size of the system. Use the indicator displayed at (b) during scanning as a guideline.

While scanning is being performed, the [Stop] button (c) is displayed. To stop scanning, click this button.

① VRF network list display during scanning

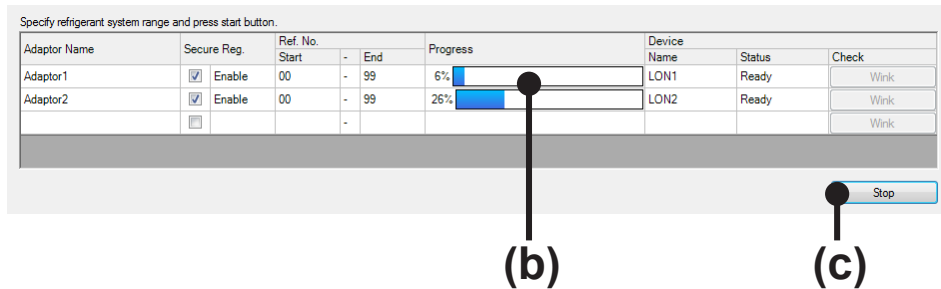

Note

If the following message is displayed after scanning is completed, the necessary information cannot be acquired.

"Information was not acquired for some units. Perform unit registration again."

In this case, always perform scan again to acquire all the necessary information.

If advanced to next as is, normal operation will become impossible.

Especially, if there is a unit for which information could not be acquired when electricity charge apportionment is performed, the refrigerant system including that unit will not be handled by the electricity charge apportionment function.

When these information missing units are included in "Unit Newly Detected", since they are displayed in red characters, treat them as the index of refrigerant system specification when rescanning.

③ Unit newly detected list:

After the end of scanning, displays the units newly detected.

At initial scanning, all the units are displayed.

After the 2nd scanning, only the units newly detected are displayed.

Model names for S/V series will not be displayed.

Note

- When there is a newly detected unit, layout setting is necessary. (See par. 8-3-5 Layout editing.)
- Depending on the R/C connected to the indoor unit, "R/C address" part of the "Address No." column may show different value from that being set to the indoor unit.
The same applies to the "Address No." and "Address" column of other screens.
The numbers in the "Address No." corresponds to "Refrigerant system address" - "Unit address" - "R/C address".

④ **Unit not detected list:**

When scanning was performed for the 2nd and subsequent times, displays the units which are already registered and were not detected this time.

Note

- As a result of performing scan, a unit of the same address may be displayed in the Unit Newly Detected list and Undetected Unit list.
This occurs when a registered unit was changed to a different model and set to the same address as the previous unit, etc.
Since the registration information of the previous unit is erased when registration is completed, continue at that setting.
- When intentionally removing a unit from registration, etc, because the unit is removed from the electric power charge apportionment objective or other reason, confirm it here. (Perform scanning after turning off the power of the unit removed from registration.)

- ⑤ [OK] button: Saves the detected unit configuration detected by scanning.
(At initial starting, [Back]: Returns to Transmission adaptor setting)
- [Cancel] button: Ends scanning without saving the scanned result.
(At initial starting, [Next]: Advances to unit name registration)

To perform setting at initial starting, advance to par. 8-3-4 Unit name registration by clicking the [Next] button.

8-3-4 Unit name registration

Allocates unit names to the R/C group of indoor unit and outdoor unit group registered by scanning so that the user can easily identify units.

(Names allocated automatically can also be used.)

Unit name registration options

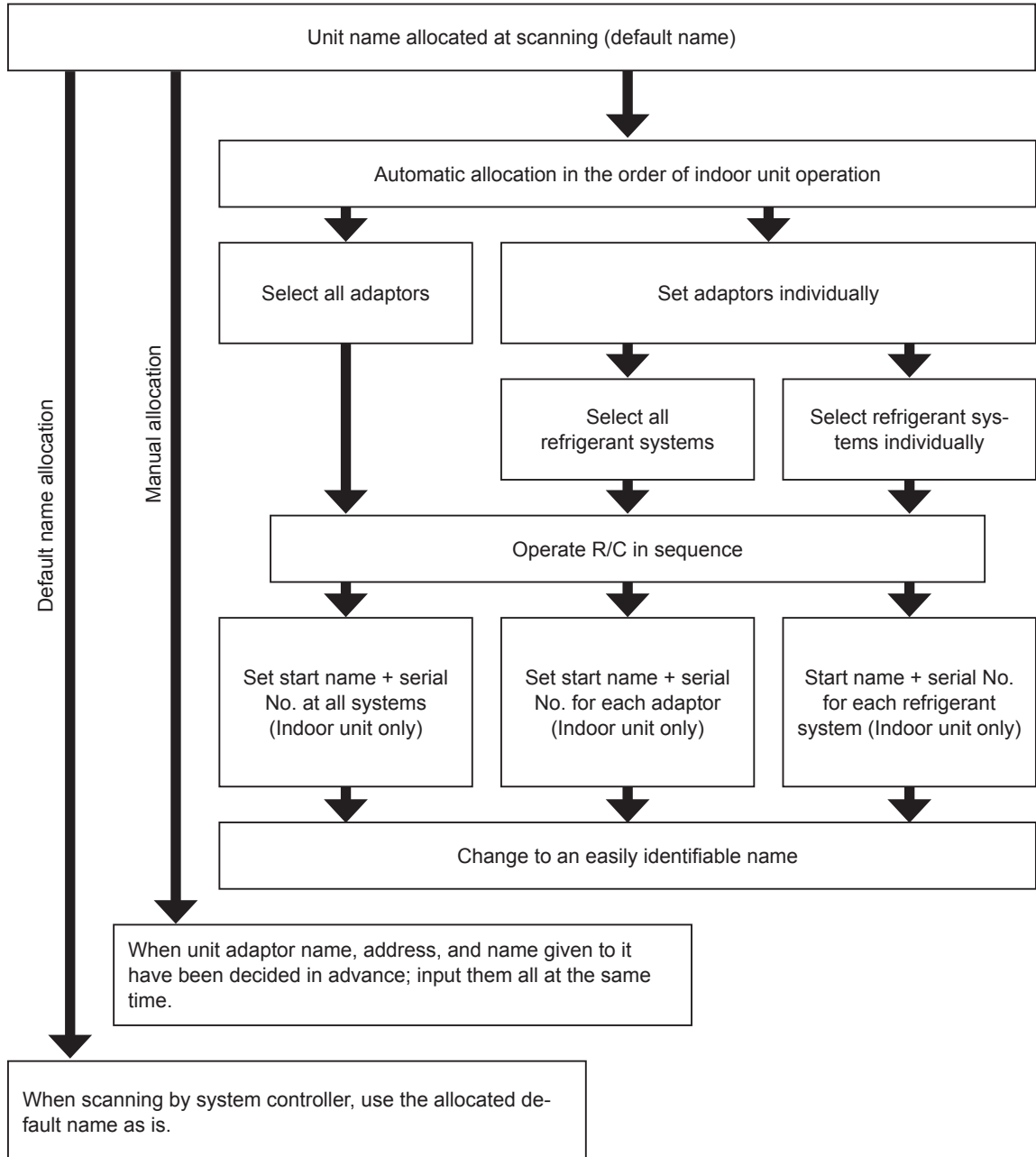

At automatic allocation in the order of indoor unit operation, assign serial numbers to the units in the order in which the units are operated.

Note

When automatic allocation in the order of indoor unit operation was performed, register the relationship between unit and serial No.. After automatic allocation in the order of indoor unit operation is finished, change the names based on that registration to names by which the units can be easily identified.

To display this screen, select main screen menu → “Setting” → “Initial Setting” → “Unit Name Registration”

Description of Unit name registration screen

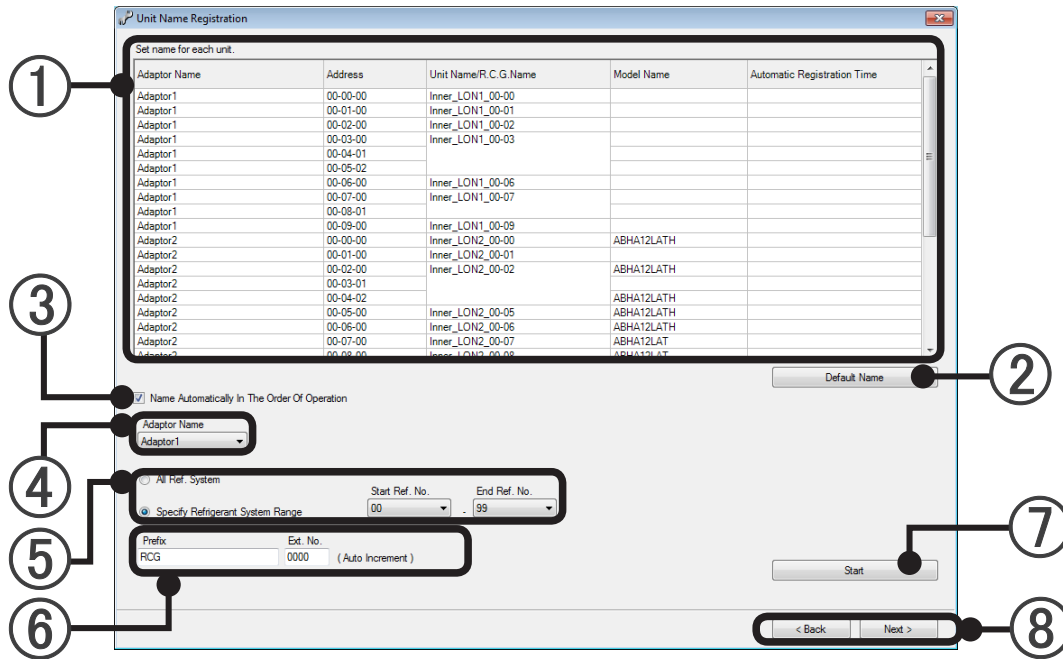

- ① **Unit list:** Displays a list of all the units registered by scanning. Changing to ascending order/descending order sorting of the selected column is possible by clicking the header part of the list.

Adaptor Name	The names of the connected adaptors are displayed. (Name set by par. 8-3-2 Transmission adaptor setting.)
Address	“Refrigerant system address” – “Unit address” – “R/C address”
Unit Name/ R.C.G. Name	R.C.G. Name, outdoor unit group name When ③ is not checked, editing is possible. Within 20 characters (Alphabet, numeric, and symbol). Blanks are not allowed.
Model Name	Model name*
Automatic Registration Time	Displays the operation ON detection time

*The letter “.” as the last letter of the Model Name signifies that the Model Name for the corresponding unit was written after shipment. The letter “.” is not part of the Model Name.

- ② **[Default Name] button:**
Returns all the R/C group and outdoor unit group names to their default names.
- ③ **Name Automatically In The Order Of Operation checkbox:** When checked, ④, ⑤, and ⑥ can be set and automatic allocation can be performed in indoor unit operation order. Unit name cannot be changed from the unit list of ①.
- ④ **Adaptor Name:**
To perform automatic name setting over an entire VRF network, select “All”.
(When “All” was selected, ⑤ cannot be set.)
To perform setting by specifying a refrigerant system range, select “Specify Refrigerant System Range” and specify the start number and end number of refrigerant system.
If you select “All” and then execute, all units will stop.

⑤ Refrigerant system name:

To perform automatic name setting at all the refrigerant systems, select "All Ref. System".

(The unit names in the refrigerant systems become the same Start name + serial No.)

To perform setting by specifying a refrigerant system range, select "Specify Refrigerant System Range" and specify the start number and end number.

(Arbitrary Start name + Serial No. for each specified refrigerant system.)

When the selected start No. is larger than the end No., the end number is automatically set to the same value as the start No..

When the selected end No. is smaller than the start No., the start No. is automatically set to the same value as the end No..

⑥ R/C group name setting:

The R/C group and the name of the start name and serial No. combination are set for each refrigerant system specified at ⑤. (Indoor unit only)

Prefix	Ext. No.	[Auto Increment]
RCG	000	

Prefix: Specifies the arbitrary character string given to beginning of the name set at a detected R/C group. (Within 16 characters of alphabet, numeric, and symbol)

Ext. No.: Specifies the start value and number of digits of the number given at the end of the name set at a detected R/C group. Numerical string only.

When the number exceeded the specified number of digits, the necessary Numerical string only. (Within 4 digits)

0 → 1 digit starting from 0 (0, 1, 2, ---9, 10, 11---)

0021 → 4 digits starting from 21 (0021, 0022, 0023---)

⑦ [Start (Stop)] button:

Starts the operation detection mode. The operation detection mode is ended by [Stop] button.

In the operation detection mode, the target network and refrigerant system range units are monitored.

Serial numbers are assigned to units in the relevant refrigerant system range in the order in which the units were operated by R/C and they are displayed at the top line of ① Unit list.

⑧ [OK]:

Saves the edited contents and ends editing work.

(At initial starting, [Back]: Returns to unit registration)

[Cancel]: Ends editing work without saving the scanned result.

(At initial starting, [Next]: Advances to layout editing)

To perform setting at initial starting, advance to par. 8-3-5 Layout editing by clicking the [Next] button.

8-3-5 Layout editing

Creates and edits the site, building, and floor monitoring screen layout.

To display this screen, select main screen menu → “Setting” → “Initial Setting” → “Layout Edit”

8-3-5-1 Layout Edit screen

(Example of screen with site edit selected)

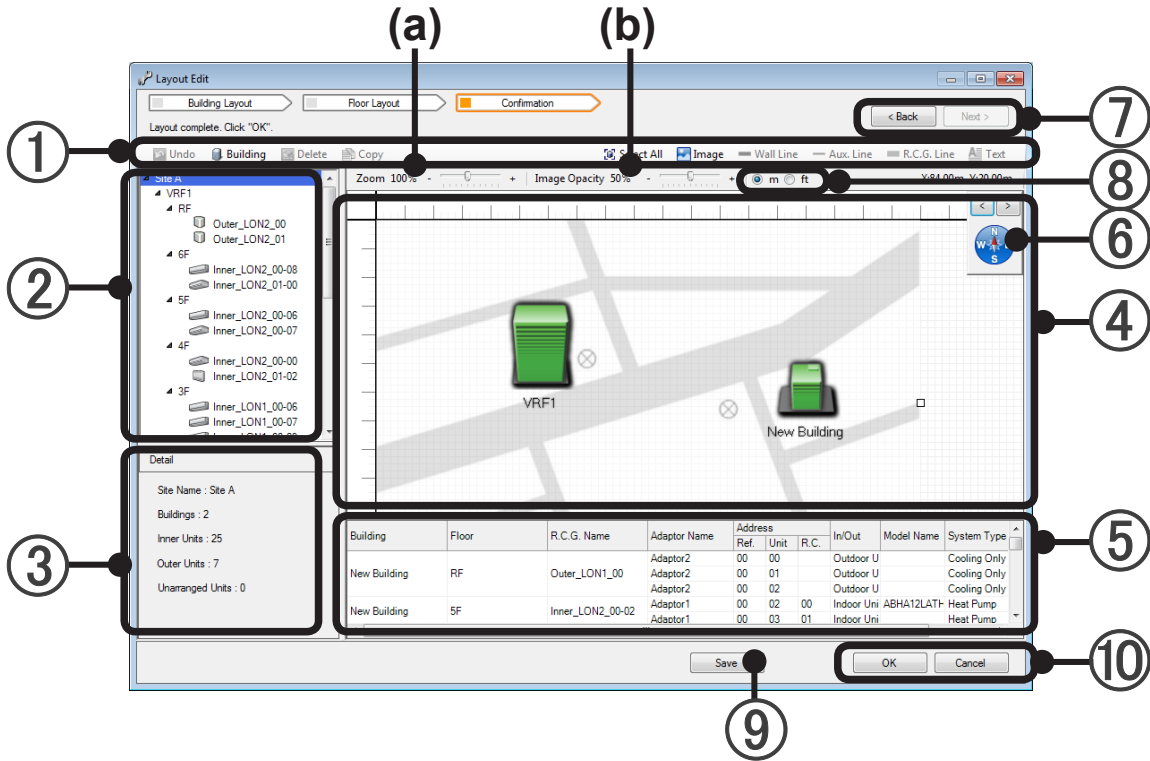

* At initial starting, part of this screen is different.

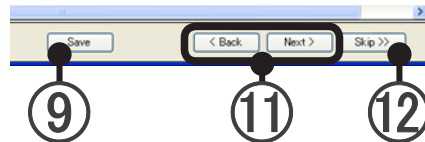

- ① **Tool bar:** Selects the work item.
(The illustration is for description. The items which can be selected differ with the work contents.)



Undo	Deletion of building and unit, line, or other object can be undone only once.
Building	Creates a new building.
Delete	Deletes a building and unit, line or other object.
Copy	The floor information (except unit and RCG Line) can be copied to another floor.



Select All	Selects all the items on the edit screen (4).
Image	Site editing and floor editing. Pastes an image of a map, floor plan, etc.
Wall Line	Floor editing. Creates a new building wall line.
Aux. Line	Floor editing. Creates an auxiliary line.
R.C.G. Line	Floor editing. Creates an R/C group line.
Text	Floor editing. Pastes a text.

For details, see par. 8-3-5-3 Building editing, 8-3-5-2 Site editing, 8-3-5-4 Unit arrangement, and 8-3-5-5 Floor editing.

- ② Tree view: Site, building, floor, unit, and group can be displayed and selected.
 The edit screen ④ is switched according to the selected item.
 When the selected item is clicked again, the name can be changed.
 (Within 20 characters of alphabet, numeric, and symbol)

(Example of screen with building selected)

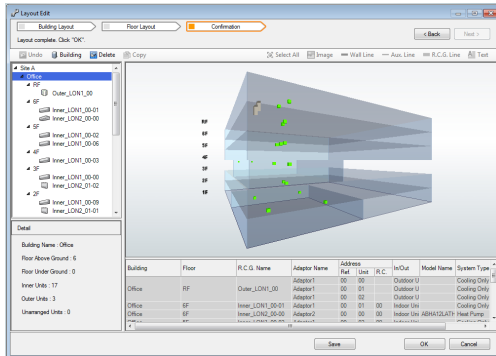

(Example of screen with floor selected)

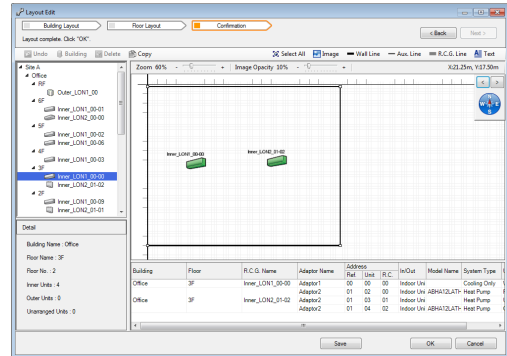

- ③ Information display: Displays the information of the item selected at the tree ②.

- ④ Edit screen: Edits the item selected at the tree ②.

Zoom inside the screen can be adjusted at (a) and the opacity of the background image can be adjusted at (b).

Screen move

The entire screen can be moved by dragging the mouse using left button.

Zoom

Zoom in and zoom out are possible by turning the mouse wheel.

Icon move

A building and unit can be selected and moved using the cursor keys (↑↓←→).

- ⑤ Unit list: Displays a list of the units belonging to the item selected at the tree view of ②.

* When there is a unit which is not arranged, it is always displayed here against a red background.

- ⑥ Azimuth: Sets the bearing at site editing and floor editing.

Make this a guideline which takes sunshine into account. North can be set with the [<] and [>] buttons.



- ⑦ [Next] button: Advances to the next setting in Layout editing.

[Back] button: Returns to the preceding setting in Layout editing.

Note

[Next] and [Back] of ⑦ are move buttons only in Layout editing.

Movement among settings can be performed freely during layout work.

- ⑧ Unit of length: Select the unit of length from meter (m) or foot (ft).

Note

The conversion rate of length differs from the actual rate. (1m = 4ft)

- ⑨ [Save] button: Saves the settings midway in the work.
- ⑩ [OK] button: Saves the settings and ends setting work.
[Cancel] button: Ends setting work without saving the settings.
(When [Save] was performed during work, it cannot be undone by [Cancel].)
- ⑪ [Back] button: Returns to par. 8-3-4 Unit name registration. (Displayed at initial starting only)
(When [Save] of ⑧ is not performed, the work contents are discarded.)
[Next] button: Saves the work contents and advances to par. 8-3-6 Group setting after setting is complete.
(Displayed at initial setting only)
- ⑫ [Skip] button: Advances to par. 8-3-6 Group setting without completing Layout editing.
(Displayed at initial starting only)
The skipped setting items can be set later, but complete them before beginning operation.

Note

The [Next], [Back], and [Skip] buttons of ⑩ and ⑪ are displayed at initial starting only.

8-3-5-2 Site editing

The site layout screen can be edited. The building (see par. 8-3-5-3) layout and background image are loaded. (Image format: .jpg, .png)

Make 1000m(4000ft)x1000m(4000ft) the guideline for the size of the editing area.

Note

The size of read background image will affect performance. So please make the total size of build layout or background image to be less than 50MB at a maximum.

When multiple adjacent buildings were set, etc., a map or other image can be loaded at the background and the actual image approached and the buildings easily identified. (The user shall provide the images.)

Example of loading of map image



Example of loading of pattern image

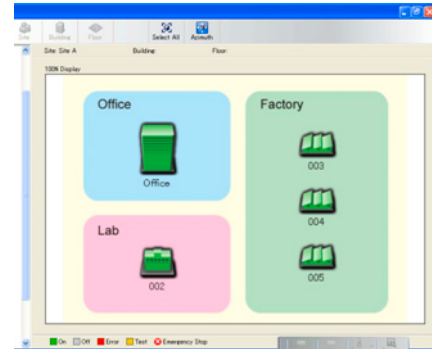
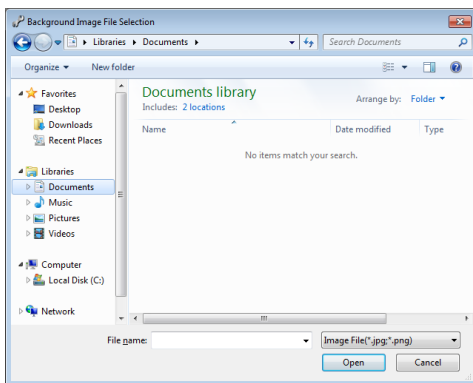
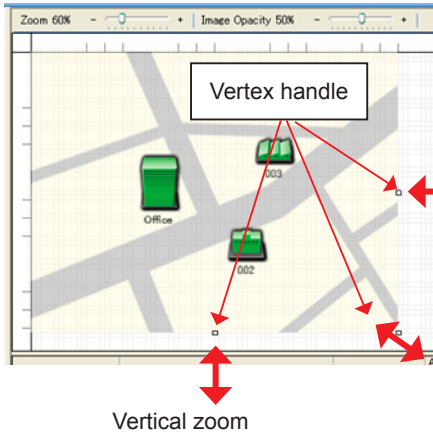

Image loading method

1. Click the [Image] button on the ① tool bar.
2. Select an arbitrary image file from the file selection dialog box.
(Default: My Documents folder)



Laying out the background [image] and buildings



The size and aspect ratio can be adjusted by clicking the vertex handle of the background image. Align with arranged background image and lay out by dragging the buildings.

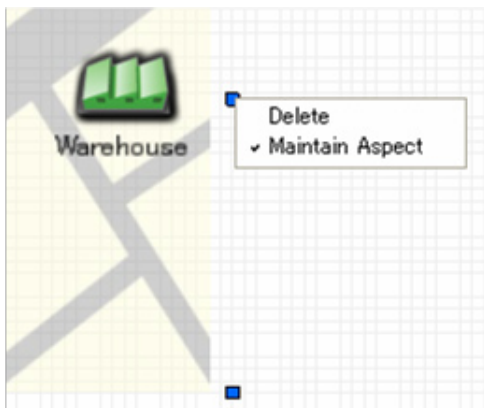

Vertex handle right click menu

“Delete”:

Deletes the images from the top of the layout screen.

Maintain Aspect:

When checked, zoom can be performed while maintaining the aspect ratio.

Opacity of background image

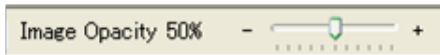
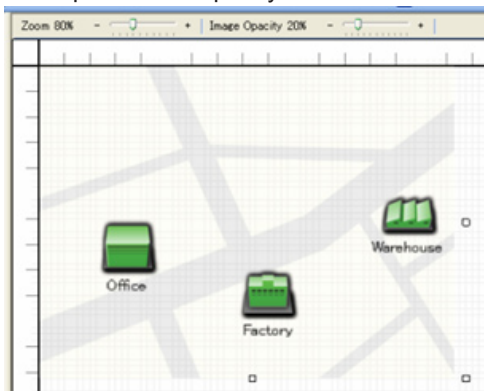

Image opacity adjustment tracking bar:

When the building icon is obscured by the background image and difficult to see, adjust it here.

Example of 20% opacity



Example of 100% opacity



Edit screen zoom function



Zoom tracking bar:

The Edit screen display size can be adjusted. (It can also be adjusted by mouse wheel operation.)

Example of zoom out display

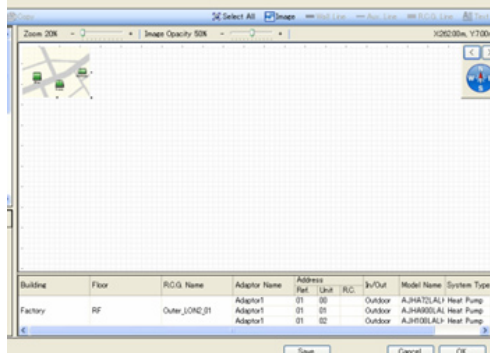

Example of zoom in display

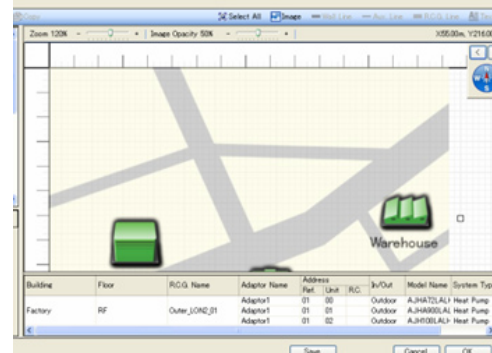

Note

- The zoom tracking bar adjusts the screen display size. It cannot adjust the size of the background image.
- Adjustment is possible by image opacity adjustment tracking bar only when layout is edited.

8-3-5-3 Building editing

Create a new building.

Create a "Building" with the units to be controlled arranged. (Up to 20 buildings can be created.)

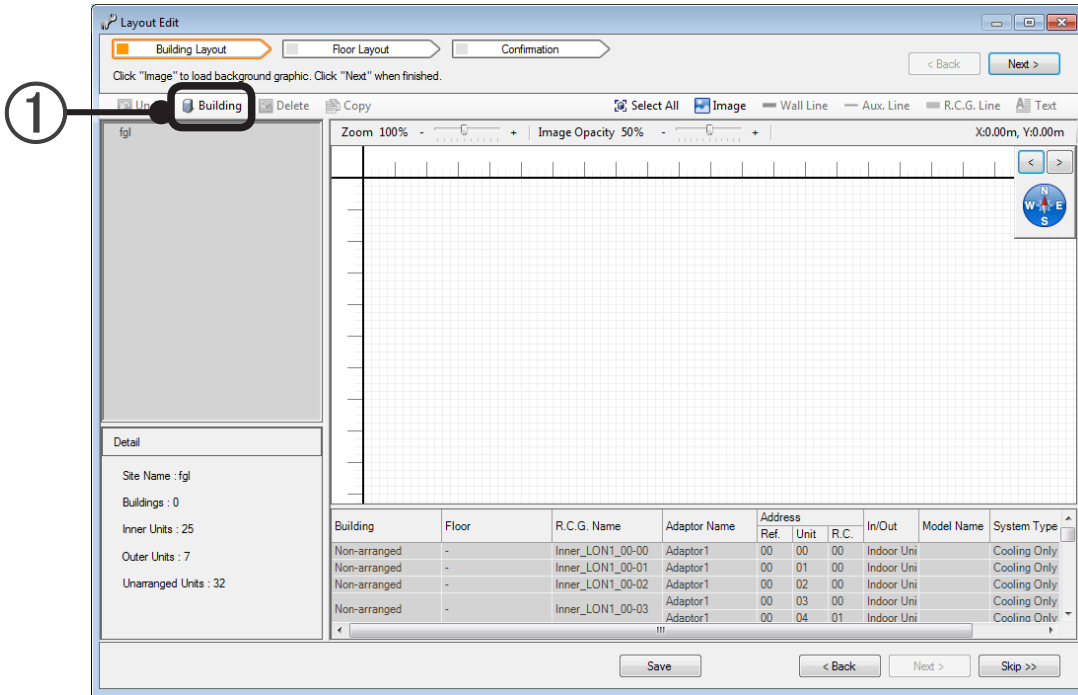

1 Click the [Building] button. The Building Setup window opens.

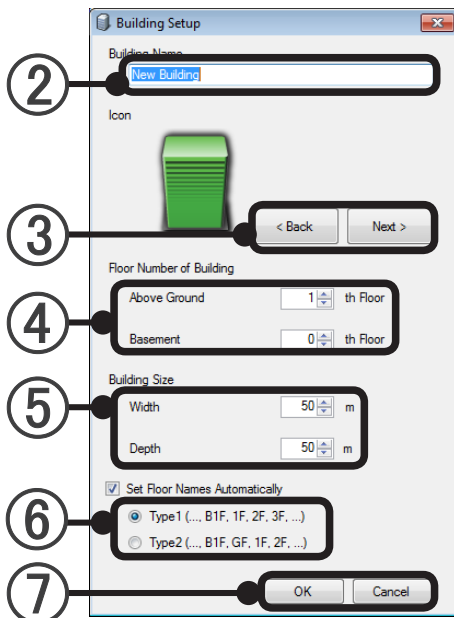

- 2 Input the building name. (Up to 20 characters of alphabet, numeric, and symbol can be input, but only the first 7 characters are displayed on the Site monitor mode screen.)
- 3 The building icon can be changed. (Select an icon closely resembling the actual image.)
- 4 Set the number of floors above ground and the number of basements of the building. (Up to 50th floor in a total of above ground and basement can be set.)
- 5 Set the width and depth of the building. (Setting range: 1 to 200 m (4 to 800 ft), Cannot be changed later)
- 6 Automatic setting of floor names can be selected. If checked, floor name (Type1) or (Type2) can be selected.
- 7 At the end of setting, click the [OK] button. When the [Cancel] button is clicked, building creation is aborted and the Building Setup screen is closed.

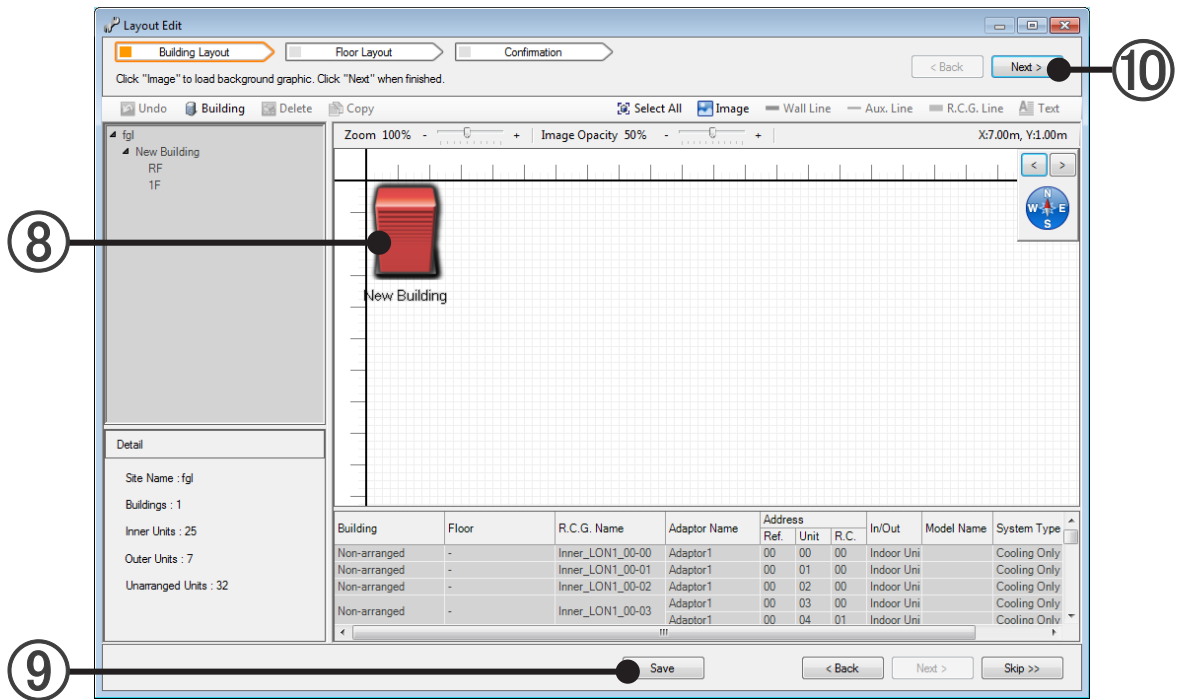

- ⑧ Create a new Building. Since the location is not specified when red, drag the building to a suitable position. A multiple building can be created by repeating steps ① to ⑦. Later the settings can be changed and a background image pasted.
- For details, see par 8-3-5-2 Site editing.

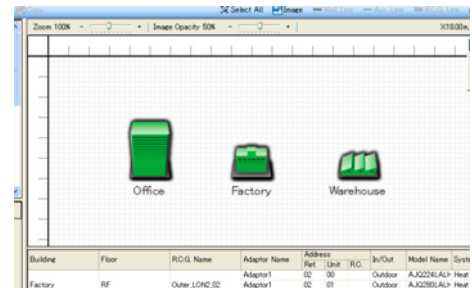

Building information change

Select "Setup" by right clicking the icon of the building to be changed. Settings ②, ③, ④, and ⑥ can be changed.



Building deletion

Select the icon of the building to be deleted and click "Delete" on the tool bar. Or right click on the icon of the building to be deleted and select "Delete".

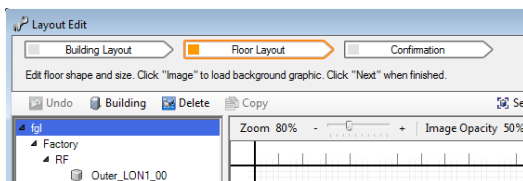

or



- ⑨ Work can be saved with the [Save] button.
- ⑩ When finished, click the [Next] button at the top right-hand corner of the screen.

8-3-5-4 Unit arrangement

Arrange the units on each Floor of the created Building in accordance with the actual installation.
 (The screen is the example of initial starting. The settings can be changed later. In this case, click the (a) [Skip] button.)

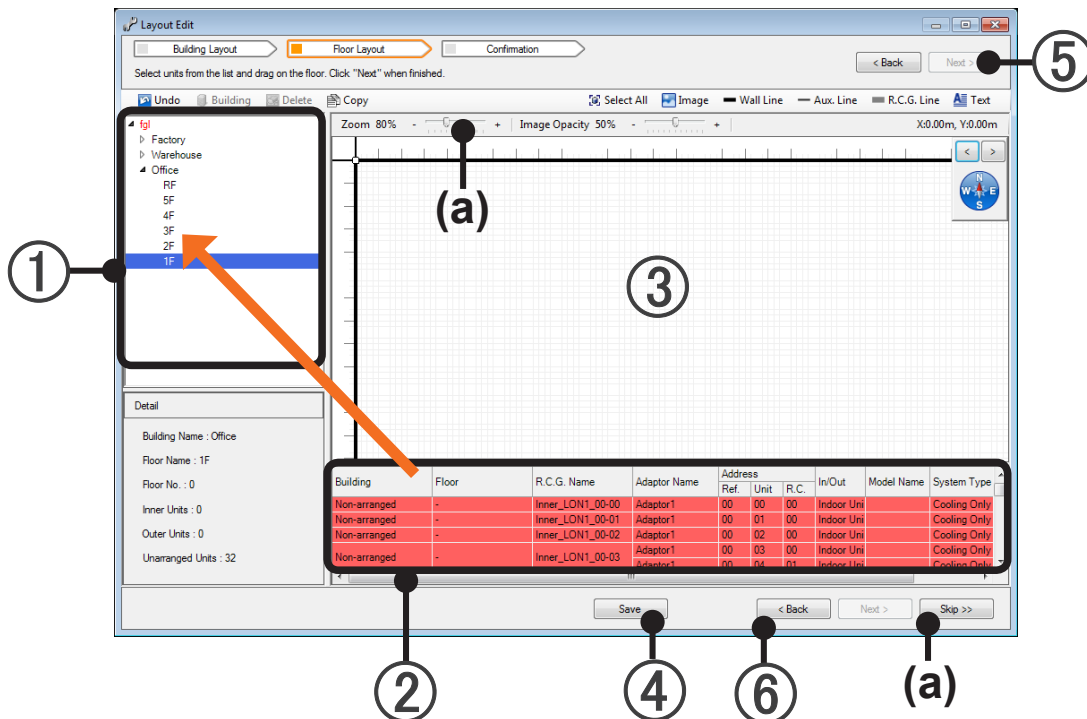

- ① Select the floor on which the units are to be arranged at the tree view screen.
You can change the floor name by using right-click.
- ② Drag the units to be arranged in the unit list to the arrangement destination floor of ① or ③ floor layout.
The arranged units are displayed on ① tree view screen
Arrange the units by referring to the work specifications, etc.
(When setting multiple buildings, pay careful attention to the arrangement destinations.)
- ③ When a floor is selected at the ① tree view screen, the ③ Edit screen simulates the floor plan of the selected floor and displays the icons of the units arranged on the floor. Since in the initial state the units are arranged in a row from the left top, the units can be arranged like that by dragging the icon of each unit while adjusting the scale by moving the (a) zoom bar (also possible with the mouse wheel).
Pasting of a map or other background image, creating the wall lines of a more complex building, displaying zones by auxiliary line, and displaying R/C group lines and text are also possible.
For details, see par. 8-3-5-5 Floor editing.
- ④ Save the work with the [Save] button.
- ⑤ At the end of setting, click the [Next] button.
- ⑥ To return to par. 8-3-4 Unit name registration and redo, click the [Back] button.
* Only at initial starting. If the work is not saved at ④, the work contents of ① to ③ will be lost.

Note

If there are unarranged units, layout display at the monitoring screen cannot be performed after setting. (List display is possible.) Always arrange all the units.

Confirmation by 3D view

Previews the layout of the entire building.

- ① When a building is selected at the tree view, the entire building is displayed in 3D and the layout of each unit on each floor can be previewed.

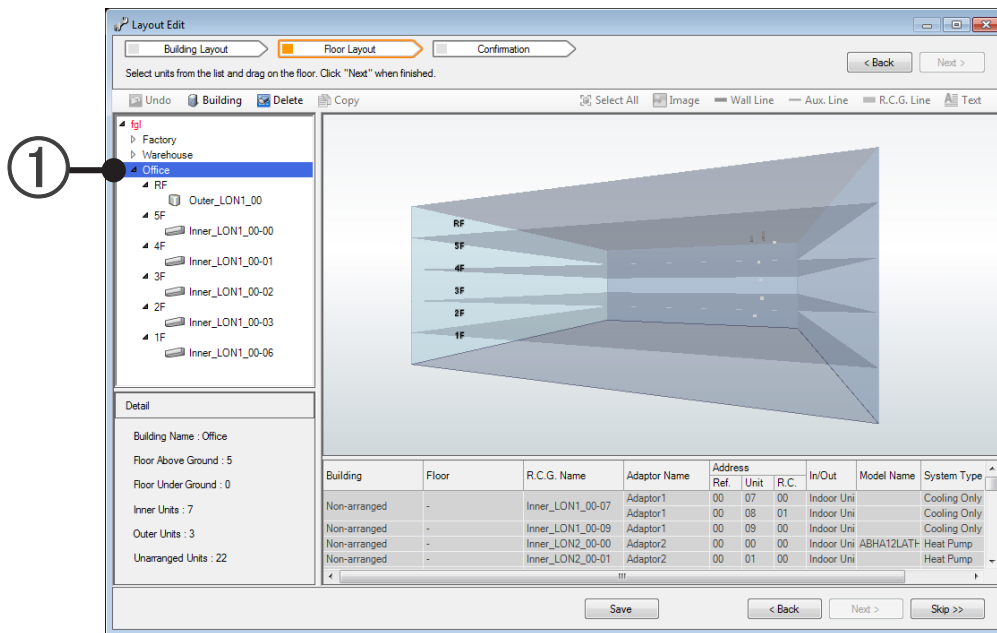

The 3D view of the building reflects the floor editing (par. 8-3-5-5) wall line setting. A view more closely resembling the actual layout is possible.

Switch to the Floor Edit (par. 8-3-5-5) screen by selecting the tree view floor.

While performing floor editing (par. 8-3-5-5), check the entire job by switching to the building overall preview screen.

Screen move

The entire screen can be moved by dragging the mouse using the left button.

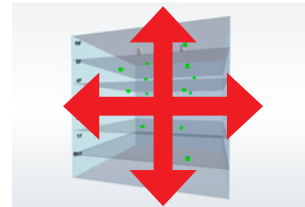

Viewpoint move

The building can be rotated up, down, left, and right by dragging the mouse using the right button.

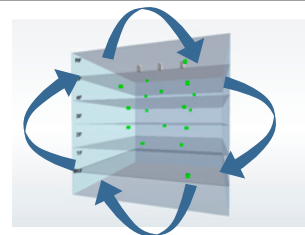

Zoom

Zoom in and zoom out are possible by turning the mouse wheel. (This operation can also be performed using the + and – keys on the keyboard.)

Note

The unit list cannot be selected during confirmation by 3D view.

8-3-5-5 Floor editing

The layout of the selected floor and units can be edited. Buildings with a more complex shape are also edited. Select the floor to be set in the ① tree view.

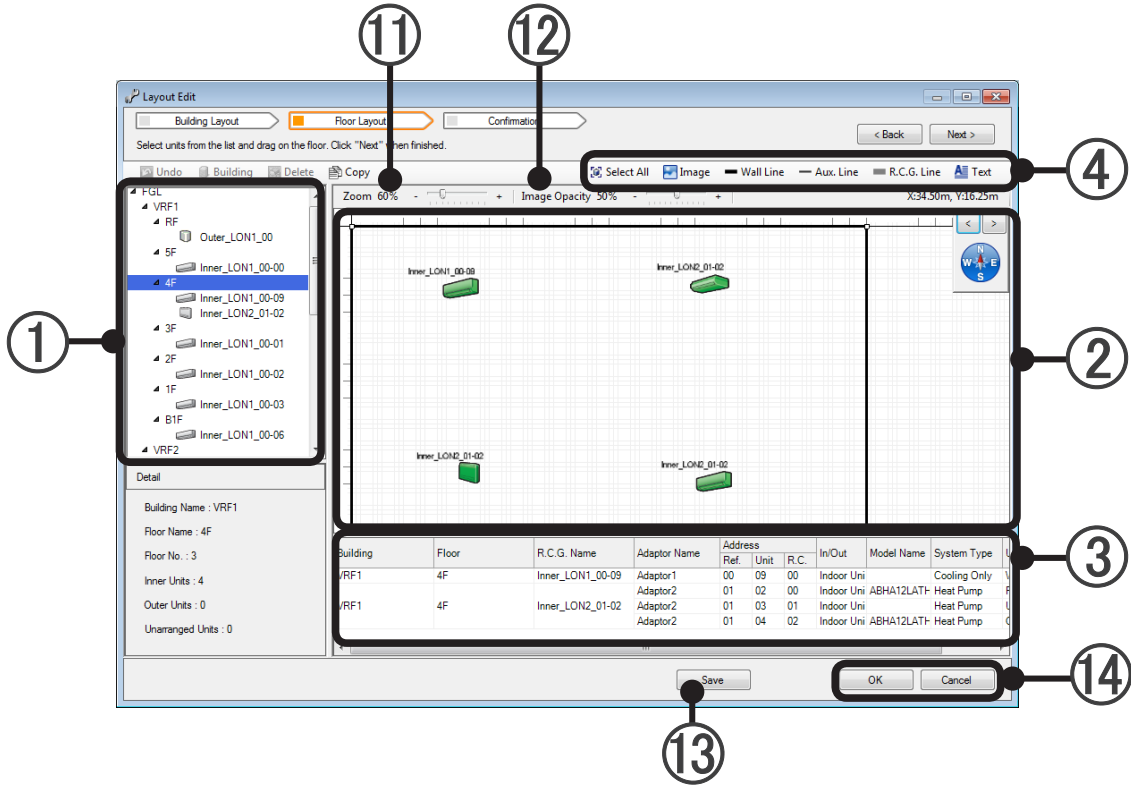

- ① Tree view
When the floor to be edited is selected on the tree view, the floor is displayed at the ② edit screen.
- ② Edit screen
This screen is displayed if there is a wall line (outline) of the building and units assigned to the floor selected at ①.
When a unit is selected at the edit screen, the selected unit is highlighted in the ③ unit list. The unit can also be selected from the unit list.
- ③ Unit list
Units unassigned and assigned to the selected floor are displayed. (Unassigned unit are displayed against a red background.)
 - Unit arrangement
Arrange the units by simulating actual installation by dragging the units with the mouse.

Note

Arrange the units by confirming the position of each unit in an R/C group and outdoor unit group by work specifications, etc.

④ Tool icons

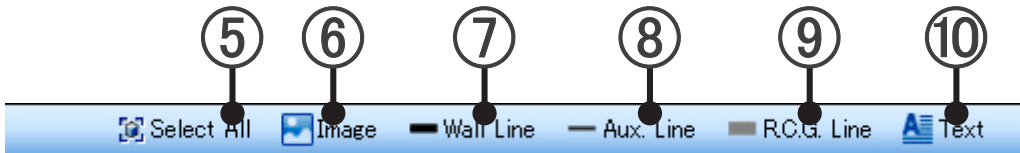

⑤ [Select All] button: Selects all the items on a floor.

⑥ Image tool: Arranges the background image on the edit screen. (Image format: .jpg, .png)
Implementation drawings can be used or a newly created floor plan can be arranged as a rough copy. (The user shall provide the images.)
The size of background image will affect performance. So please make the total size of background image to be less than 50MB at a maximum.

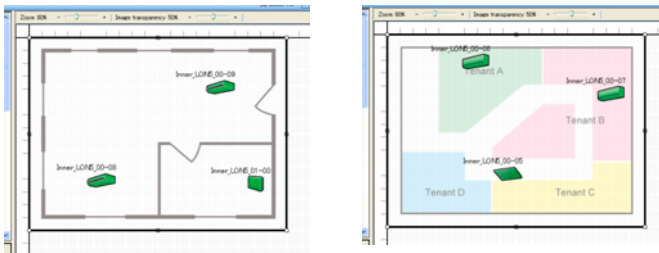

⑦ "Wall Line" tool: Creates a new wall line.

Please paint with "Wall Line" on the outside wall of building. "Wall Line" will be reflected on 3D building.
When ⑦ is selected and the edit screen is clicked, a 1m(4ft)X1m(4ft) wall line is created. (Up to 4 places/floor)
The wall line can be edited as follows.
(Wall line editing is also performed on existing wall lines.)

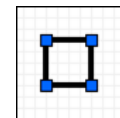

- Wall line and vertex shift: An arbitrary position and size can be created by dragging the wall line (side) and vertex handle. Multiple wall lines (separate building, etc.) can also be created. Since the color of the line changes when adjacent vertexes and aligned horizontally or vertically, use it as a guideline.

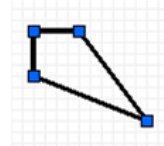

- Vertex addition: Vertex addition can be selected by right clicking the vertex of a wall line (side). (The number of peaks is within 50. Intersecting wall lines cannot be created.)
More complex wall lines can be created by adding vertexes and wall lines. (Up to 4 wall lines can be created per 1 floor.)

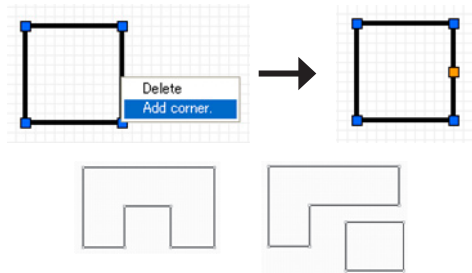

- Vertex deletion:
Select the "Delete Corner" by right clicking the vertex handle. (The number of vertexes cannot be less than 2. Also, vertexes cannot be deleted when wall lines intersect.)

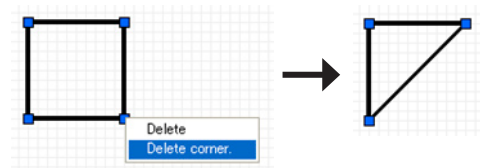

- Wall line deletion: Select the wall line (side) and click the “Delete” key or right click the wall line and select “Delete”. (When there is not even one wall line on the floor, deletion is impossible.)

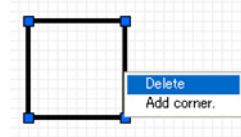

- ⑧ “AUX. Line” tool: Creates an auxiliary line. Please paint with "AUX.Line" on each maintenance wall. "AUX.Line" will be reflected on floor display only. It can be freely used, and is convenient for lines, etc. which show the unit positions and tenant boundaries on a floor. An auxiliary line is created when ⑧ is selected and 2 arbitrary points on the edit screen are clicked. A line having an arbitrary position and length can be created by dragging the line (side) or vertex handle. (Vertexes cannot be added.)

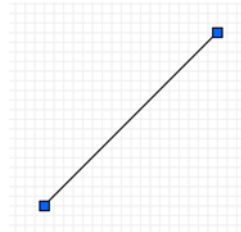

- Auxiliary line deletion: Select the line (side) and click the “Delete” key or right click the line and select “Delete”.

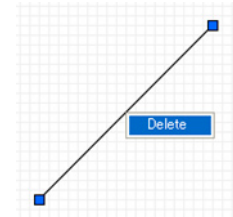

- ⑨ “R.C.G. Line” tool: Creates an R/C group connecting line. When ⑨ is selected and 2 units in the R/C group on the edit screen are selected, a line is created. The R/C group can be easily identified by displaying a connecting line. (Different line from constructed R/C group cannot be created.)

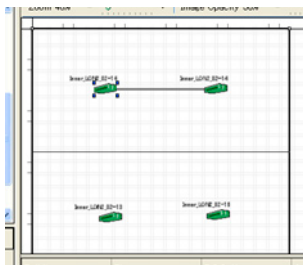

Building	Floor	R.C.G. Name	Adaptor Name	Address		R/C	In/Out	Model Name	System Type
				Rel.	Unit				
Factory	1F	Inner_I0N2_02-13	Adaptor1	02	13	00	Indoor	ARQB02SALL Heat Pump	
Factory	1F	Inner_I0N2_02-14	Adaptor1	02	14	00	Indoor	ARQB04SALL Heat Pump	
Factory	1F	Inner_I0N2_02-15	Adaptor1	02	15	01	Indoor	ARQB04SALL Heat Pump	
Factory	1F	Inner_I0N2_02-16	Adaptor1	02	16	00	Indoor	ARQB06SALL Heat Pump	

Use the ③ unit list to confirm the connection sequence. RC No. 00 is the Main Unit. When there are multiple Slave Units, create connecting lines in No. order. (The illustration shows the state in which Main Unit is selected at an R.C group.)

- ⑩ “Text” tool: An arbitrary character string can be created. When ⑩ is selected and an arbitrary position on the edit screen is clicked, text can be input. The unit names, tenant names, etc. on the floor and arbitrary comments can be displayed. The text can be moved by dragging the vertex handle. (Line feed cannot be performed and font type and size cannot be changed.) Within 20 characters of alphabet, numeric, and symbol.



- Text deletion: Select the text and click the “Delete” key or right click the text and select “Delete”.

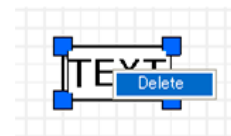

- ⑪ “Zoom” slider: The size of the display screen can be changed.
- ⑫ “Opacity” slider: The opacity of the images arranged on the display screen can be changed during Site Editing and Floor Editing.
- ⑬ [Save] button: Saves the work contents midway through the work.
- ⑭ [OK] button: Saves the settings and ends setting work.
[Cancel] button: Ends setting work without saving the settings. (When [Save] was performed during work, you cannot return to the previous state.)

Floor layout copy

“Outer Wall Lines”, “Auxiliary Lines”, “Text”, and “Back Ground” in the created layout can be copied to another floor. (Units and RCG lines cannot be copied.)

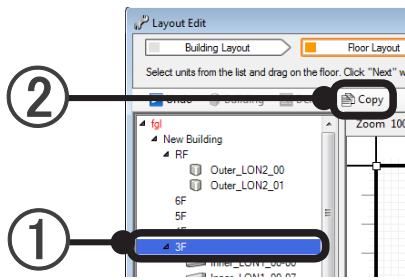

- ① Select the copy source floor on the tree view.
- ② Click the [Copy] button.
(The “Copy” button cannot be clicked if a hierarchy below the floor on the tree view is not selected.)

A “Copy Floor Layout” dialog box opens.

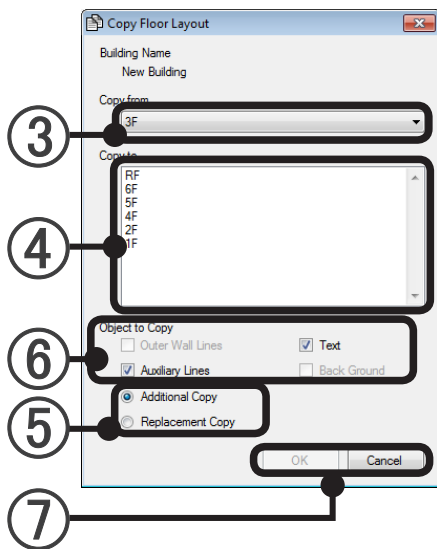

- ③ Confirm the copy source floor.
(Can be changed by pull-down menu.)
- ④ Select the copy destination floor.
(Multiple floors can be selected by +Shift key or + ctrl key)
- ⑤ Select the copy method.

<p>“Additional Copy”: Adds new information to the copy destination information.</p>

<p>“Replacement Copy” Deletes the copy destination information and replaces it with new information.</p>
--

- ⑥ Select the item to be copied.

<p>Building outer wall. (Only when “Replacement Copy” is selected at ⑤.)</p>
--

<p>Text</p>

<p>Auxiliary line</p>

<p>Background (Only when a background image is arranged on the copy source floor and “Replacement Copy” is selected at ⑤.)</p>
--

- ⑦ [OK]: Executes copy with the set contents and ends.
[Cancel]: Ends without executing copy.

To perform setting at initial starting, advance to par. 8-3-6 Group setting by clicking the [Next] button.

Note

When layout is edited, the monitoring screen is closed. To display the monitoring screen after the edit completes, click the main menu screen → “Display” → “Unit Layout”

8-3-6 Group setting

Arbitrary group setting and change are possible at multiple units, outdoor units, R/C group, and outdoor unit group. (Up to 3 hierarchies)

Batch control and data acquisition are possible by setting a group.

Group setting at different refrigerant systems and duplicated setting at multiple groups are also possible.

Group concept

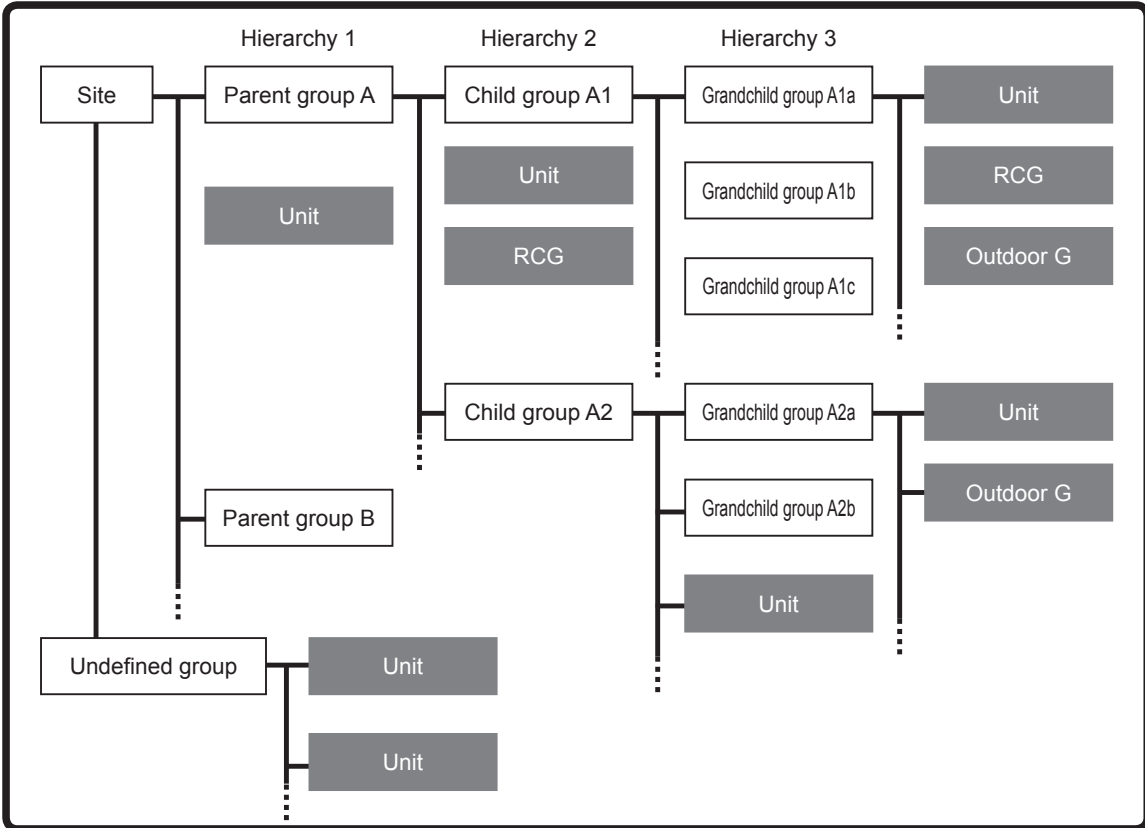

Settings

Example of group setting

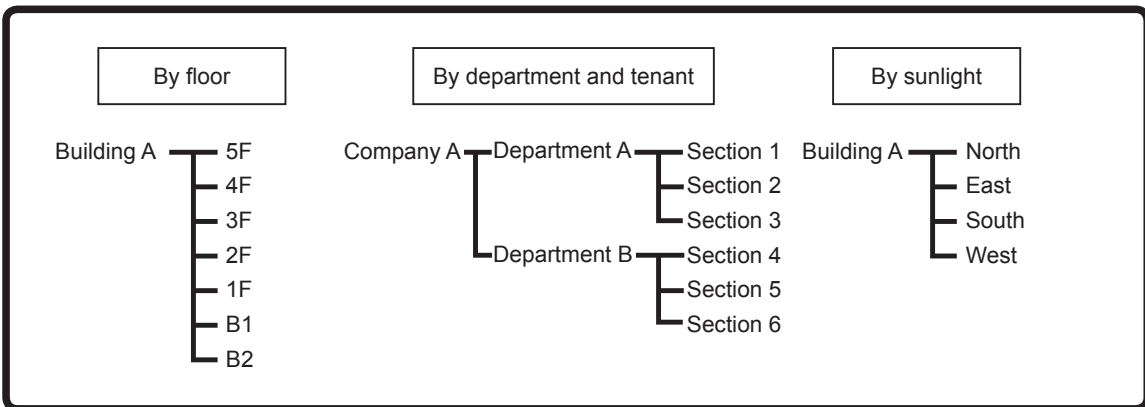

Perform group setting.

To display this screen, select main screen menu → “Setting” → “Initial Setting” → “Group Setting”

Description of Group Setting screen

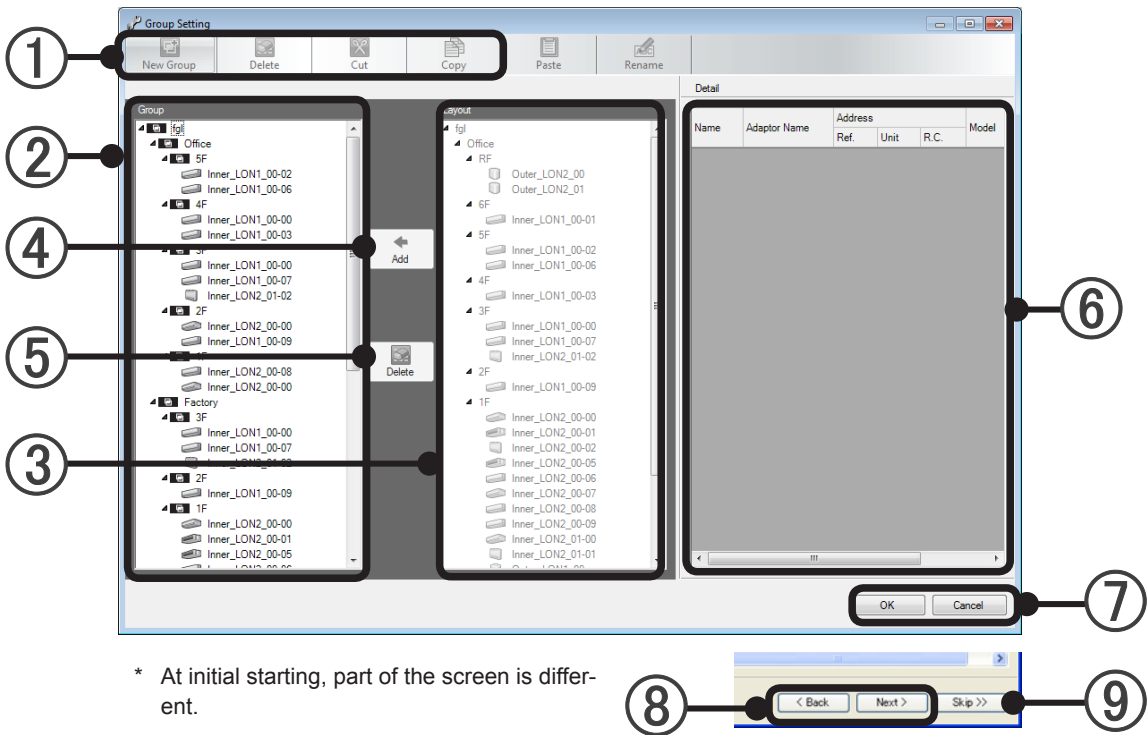

* At initial starting, part of the screen is different.

- ① Tool bar: Selects the work item.
(Depending on the work contents, the items which can be selected are different.)

New Group	Creates a new group under the hierarchy (group) selected at ②.
Delete	Deletes the Group selected at ② or releases a unit in a group. This is the same function as the ⑤ [Delete] button.
Cut	Performs cutting when you want to move a selected group and unit. Movement is complete when the move destination is selected as is and [Paste] is clicked.
Copy	Performs copy when you want to duplicate a selected group and unit. Duplication is complete when the move destination is selected as is and [Paste] is clicked.
Paste	When the [Cut] move destination and [Copy] destination are selected and clicked, the group and unit are pasted.
Rename	When the group and unit whose name you want to change are selected and this button is clicked, the new name can be input (Within 20 characters of alphabet, numeric, and symbol).

Note

Regarding the tool bar work items, the same operations are possible by right clicking the mouse on the unit and hierarchy you want to set.

- ② Group tree: Tree view of the currently set groups. Units which can be selected but are not set in a group are displayed in Undefined Group at the very bottom.
- ③ Layout tree: Tree view of the units installed at the site for each building and floor.
- ④ [Add] button: Sets the units selected at ③ at the group of the position selected at ②.
- ⑤ [Delete] button: Deletes a group set at ② or releases a unit.
This is the same function as the [Delete] button in the ① tool bar.

- ⑥ Information list: Displays the selected unit information by either group tree or layout tree. (Editing cannot be performed on the information list.)

Name	Displays R/C group or outdoor unit group name. (Name set by par. 8-3-4 Unit name registration.)	
Adaptor Name	Displays the name of the connected adaptor. (Name set by par. 8-3-2 Transmission adaptor setting).	
Address	Ref.	Displays the refrigerant system number.
	Unit	Displays the unit number in the refrigerant system.
	R.C.	Displays the R/C group connection order. "0" is the master unit. (Blank when outdoor unit selected)
Model	Displays the icons in an R/C group and outdoor unit group in a list.	
Model Name	Displays the model name of the units in an R/C group and outdoor unit group in a list.*	

*The letter "." as the last letter of the Model Name signifies that the Model Name for the corresponding unit was written after shipment. The letter "." is not part of the Model Name.

- ⑦ [OK]: Saves the edited contents and ends.
[Cancel]: Ends without saving the edited contents
- ⑧ [Back] button: Returns to par. 8-3-5 Layout editing. (Displayed at initial starting only)
[Next] button: Saves the work contents and completes initial setting. (Displayed at initial starting only)
- ⑨ [Skip] button: Completes initial setting without completing "Group" setting. (Displayed at initial starting only)
Skipped setting items can be set later, but complete them before operation.

Note

The [Next], [Back], and [Skip] buttons of ⑧ and ⑨ are displayed at initial starting only.

New group creation

Parallel group creation

1. Select the site in the ② group tree at which the group is to be created.
2. Click the ① [New group] button.
3. A group is created at a hierarchy below the Site selected at 1. (In this state, "Group name" can be keyed in.)
4. When the ① [New Group] button is clicked continually in the Site selected state, parallel groups are created.

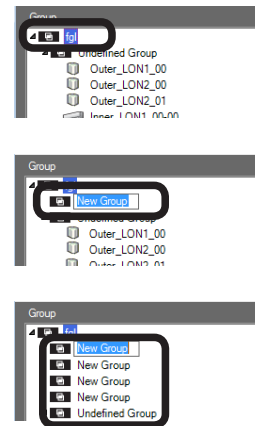

[Creation by right click]

Groups can also be created by right clicking the site at which a group is to be created in the ② group tree and selecting “New Group”.

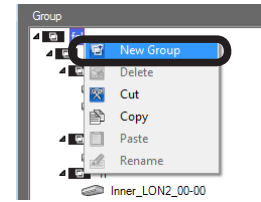

Creation of a group having a hierarchy

1. Select the group you want to add to the hierarchy in the ② group tree.
2. Click the ① [New group] button.
3. A group is created at a hierarchy below the group selected at 1.
4. When the group created at step 3 is selected and the ① [New Group] button is clicked, a group of a still lower hierarchy is created. (Up to 3 hierarchies)

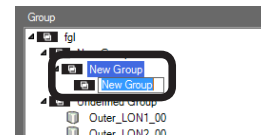
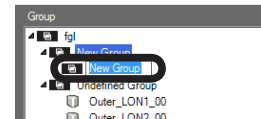
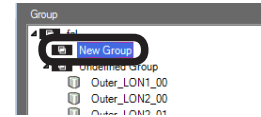

Group name change (All the newly created group names become New Group)

1. Select the group whose name you want to change in ② group tree.
2. Click the ① [Rename] button.
3. The group name selected at step 1 can be changed by text key input.

[Change by right click]

The name can also be changed by right clicking the group whose name you want to change in the ② group tree and selecting Rename.

Site name cannot be changed by this operation. (See par. 8-3-1 Site name setting.) “Undefined Group” names cannot be changed.

Arrange units to the created group.

(Arrangement by duplicating units to different groups is also possible.)

1. Select the group at which units in the ② group tree are to be arranged. (Cannot be arranged to “Undefined Group”.)
2. Select the unit or units you want to arrange in the ③ layout tree. (Multiple selection is possible by “+Shift key” or “+Ctrl key”.)
3. Click the ④ [Add] button.
4. The units are arranged in the group selected at step 1. (The arranged units are not displayed at “Undefined Group” in the ② Group tree.)

[Arrangement by right click]

Right click the unit you want to arranged in the ③ layout tree and select “Copy”.

Arrangement is also possible by right clicking the arrangement destination group in the ② group tree and selecting “Paste”. (Selection from “Undefined Group” of ② is also possible.)

Check for duplicate arranged units

1. Select the unit whose duplication you want to check in the ② group tree.
2. If there is a duplicate unit, the relevant unit in the ② group tree will be highlighted.

Moving created group and arranged units to a different hierarchy and group (When a group is moved, the units under that group follow it. In addition, movement to a position exceeding 3 hierarchies is impossible.)

1. Select the group and units whose hierarchy you want to move in the ② group tree. (Multiple selection is possible by “+Shift key” or “+Ctrl key”.)
2. Click the ① [Cut] button.
3. Select the move destination group or site.
4. Click the ① [Paste] button.
5. The group and units move to under the group or site selected at step 3.

[Movement by right click]

Right click the group and units to be moved in the ② group tree and select “Cut”. Right click one group or site above the move destination and select “Paste”.

[Movement by dragging]

Movement is possible by dragging the group and units to be moved in the ② group tree.

Delete a created group and release arranged units.

1. Select the group and unit you want to delete or release in the ② group tree. (Multiple selection is possible by “+Shift key” or “+Ctrl key”.) “Undefined Group” and “Site” cannot be deleted.
2. Click the [Delete] button of ① or ⑤. The units which are released and not belonging to any group are displayed at “Undefined Group” in the ② group tree.

[Deletion and removal by right click]

Right click the group and unit to be deleted and released in the ② group tree and select “Delete”.

Create a group with the same configuration as layout setting.

When layout setting is complete, a group with the same configuration as the arranged unit configuration can be easily created.

1. When “Building Name” is selected in the ③ layout tree and dragged directly under “Site Name” in the ② group tree, a group of the same configuration is created
When the arrangement destination shifted, delete “Building” in the ② group tree and then redo.

The same operation can also be performed using the ④ [Add] button.

1. Select “Site Name” in the ② group tree.
2. Select “Building Name” in the ③ layout tree.
3. Click the ④ [Add] button.

Note

When the group is set, the monitoring screen is closed. To display the monitoring screen after the setting completes, click the main menu screen → “Display” → “Unit Layout”

When setting at initial starting is complete, the VRF Explorer “Site Navigator” screen appears.

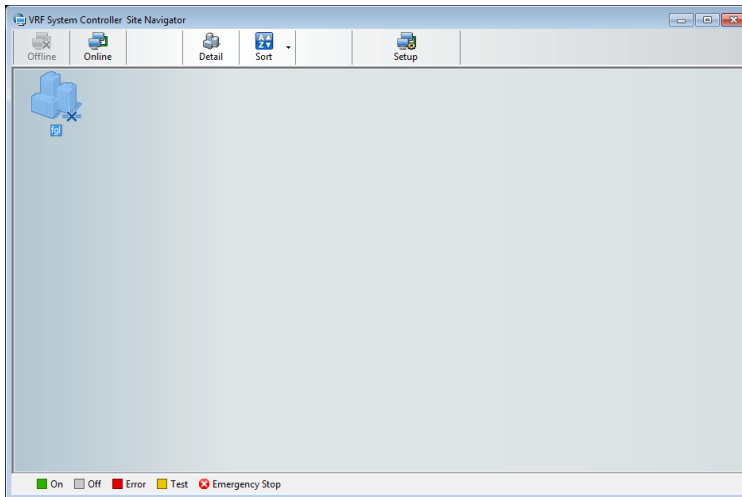

To connect to a site and continue monitoring, control, etc., double click the Site icon and log in and display the VRF Explorer main screen.

For details, see pars. 16-1-2 Communication connection to site and 16-1-4 Site details display.

9. Electricity Charge Apportionment Setting

Performs basic settings related to electricity charge apportionment necessary before operation. May also update the settings due to facility and tenant changes.

At initial starting after installation, perform setting in accordance with the following flow. For settings and changes after operation starts, perform the necessary settings in accordance with the contents of par. 9-1 and subsequent paragraphs.

Flow at initial setting

Perform initial setting in accordance with this flow.

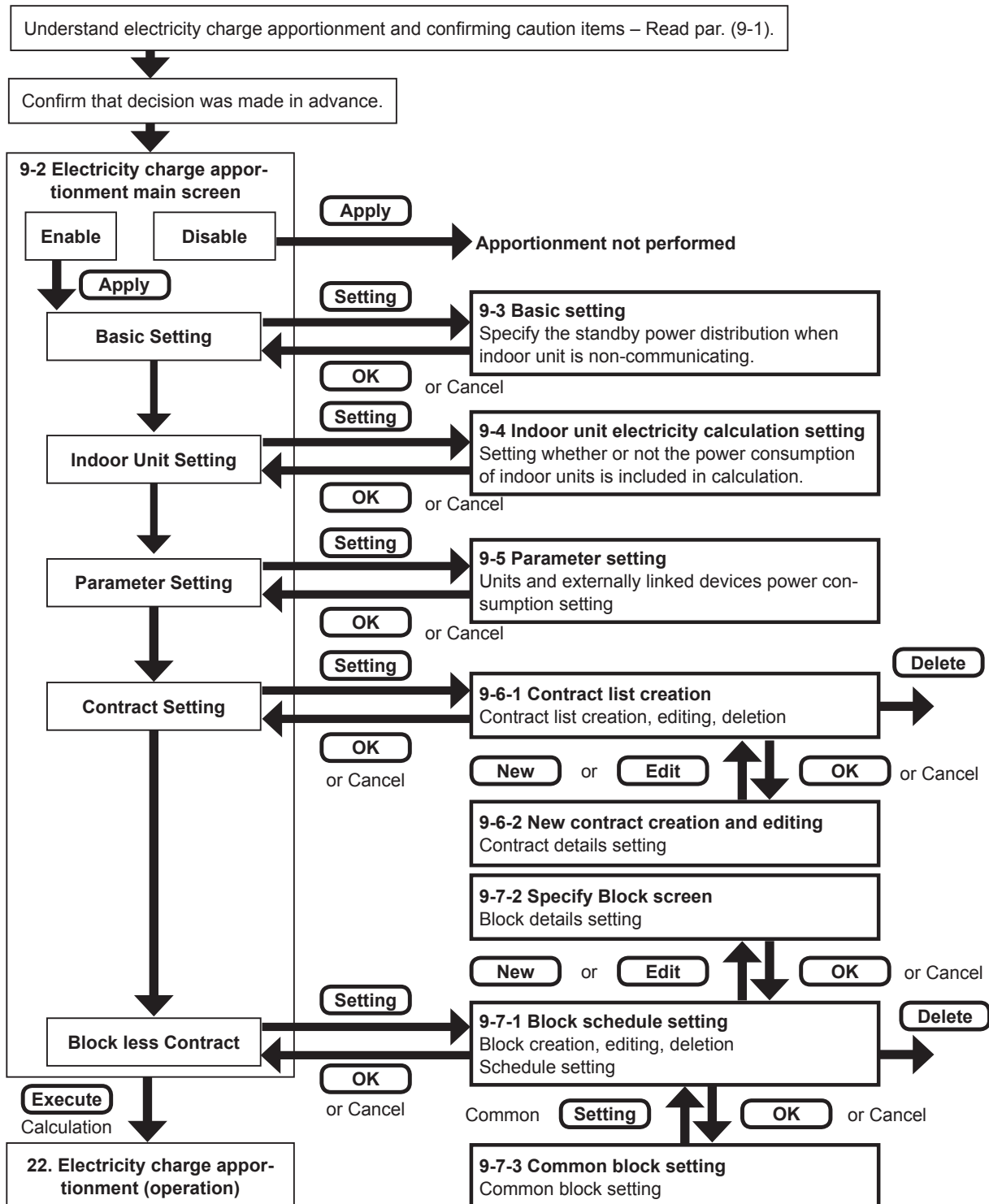

9-1 Overview

1. Purpose of electricity charge apportionment

The electricity charge apportionment function apportions air conditioner electric charges to tenants. Generally, indoor units are divided among and used by each tenant, and calculation of the electricity charge for each tenant is easy. But since outdoor units are shared by multiple tenants, calculation of the electric charge for each tenant is not easy.

The electricity charge apportionment function allows distribution of the electricity charges of outdoor units, which are a large part of the air conditioner power consumption, according to the air conditioner usage ability of each tenant.

2. Features of electricity charge apportionment of System Controller

- (1) Power meter is not used and electricity apportionment calculation is performed from the electricity charges billed from the electric power company.
- (2) Apportionment calculation is performed according to indoor unit usage ability.
- (3) In addition to electric charge calculation of outdoor units only, electric charge calculation including indoor units is also possible.
- (4) Flexible definition according to the electric charge contract configuration, block configuration, and usage period is possible.
- (5) Since the data for 1 year is saved, recalculation of the past is possible.

3. Basic electricity charge apportionment terms

The terms related to electricity charge apportionment which appear in this section are defined below.

Apportionment	Distribution proportional to basic quantity.
Contract	Billing objective of electricity charge from electric power company.
Block	Aggregate of indoor units used by building tenants. A block used exclusively by a specific tenant is called a tenant block and a block shared by multiple tenants is called a common block.
Energy used	Energy used by indoor units and outdoor units to perform air conditioning.
Electricity charge	Electricity charge billed from an electric power company. Consists of basic charge billed without regard to amount used, metering charge billed only for the amount used, additional charge billed for special reasons, etc.
Undefined block	Special block which is allocated the power consumption, etc. of indoor units which are not allocated to a tenant block or common block. Generally, electric charges considered to be borne by the building owner or manager are apportioned to an undefined block.
Parameters	Detailed unit information used in electricity charge calculation by the electric charge apportionment function.

4. Usage Precautions

- (1) The electricity charge apportionment function requires correct setting and use in accordance with the descriptions in this manual.
If correct operation based on correct setting is not performed, a reasonable result may not be obtained.
- (2) The electricity charge apportionment function does not calculate official electricity charges like those established by the laws and regulations of each country.
- (3) Gaining an understanding of the descriptions, etc. in this manual and using the electricity charge apportionment function accordingly are the responsibility of the user.
- (4) The electricity charges used in electricity charge apportionment calculation are only for the power consumed by the air conditioner.
- (5) For the electricity charge apportionment function to function properly, the VRF Controller in the server PC must be operated continuously. If the VRF Controller is shut down or stopped by a power failure, etc. while the data needed by calculation is being acquired, correct electricity charge apportionment calculation may be impossible.
- (6) Electricity charge apportionment is performed for units identified by scanning. When the unit configuration was changed, perform scanning to re-identify the objective units.
- (7) Constantly maintain the units which are the objective of electricity charge apportionment calculation in the normal operating state.
If units are left in abnormal state (power not supplied or in error), data acquisition and calculation will not be correct. The electricity charge apportionment function should not be performed during such period.
- (8) When all the indoor units managed by the system controller are not allocated to a block, etc, the electric charges may be allocated to an undefined block. The electricity charges apportionment function cannot be used to reapportion the electricity charges allocated to an undefined block. For cases which generate an undefined block, etc., see the later description.
- (9) Electricity charge apportionment calculation identifies units by address. When the address of a unit was changed by automatic addressing function, etc., perform scanning to re-identify the correct address and update the block setting, if necessary.
- (10) The electricity charge apportionment function of VRF system can only be performed from 1 controller or 1 gateway simultaneously.
- (11) You cannot calculate the start day of data collection.
- (12) Please correct the time periodically to make the date will not be changed.
The calculation of ECA will be as follow by correct time.
 - In the case of set time back, ECA data will be deleted before returned time and collect data newly.
 - In the case of set time ahead, ECA data will disappear during skip time.
 In the case that set time back to change date, please scan for the apportionment can not be calculated accurately.
- (13) When the outdoor unit power is turned off, since data is not sent, power amount measurement of the power meter is stopped.
- (14) When outdoor unit does not communicate, the apportionment calculation of the appropriate refrigerant system is not performed correctly because the data needed for apportionment is not obtained.
- (15) Specifications of electricity charge apportionment are subject to change without prior notice.
- (16) Specifications of electricity charge apportionment may be different depending on the series.
- (17) With heat recovery, the apportionment result may be different even under the same operating condition, depending on the cooling/heating operation ratio, etc. of indoor units in the same refrigerant system.
For example, the case where there are both cooling units and heating units is more efficient than the case where all units operate in cooling mode within a refrigerant system.

5. Items Decided Before Use

Before using the electricity charge apportionment function, decide each of the items below and perform setting and operation correctly based on them.

(1)	Apportionment objective range	Whether or not indoor units are included in the apportionment objectives.
(2)	Basic/additional charges apportionment method	Select from among apportionment proportional to the number, capacity, and usage ability of indoor units or equal apportionment to blocks
(3)	Common block apportionment method	Burden ratio of each block and building owner
		When apportioning to blocks, select the apportionment method from the number of indoor units, capacity, equal, or individual.
(4)	Processing of undefined blocks	An undefined block is a block with an integrated electricity charge that could not be apportioned to a tenant block by the electricity charge apportionment function. The building owner or manager may have to process the electric charges apportioned to an undefined block separately from this electricity charge apportionment function. Decide beforehand the method of processing the undefined block when an undefined block was generated. See the later description so that undefined block electricity charges are not generated as much as possible.
(5)	Contents of contract	Contents of block division in contract, present/absence of basic/additional charges, nighttime, weekend charges time, etc.

6. Overview of apportionment method

Electricity charge apportionment is performed by a suitable method corresponding to the S/V Series and V-II/J-II/VR-II Series refrigerant control system.

The following outlines the V-II/J-II/VR-II Series electricity charge apportionment method, but the conceptual processing method is also the same for the S/V Series

6.1 Fixed period processing

This processing is performed periodically for all the objective units when the electricity charge apportionment function is enabled.

- (1) The energy used by and usage ability of each outdoor unit and indoor unit are calculated in accordance with the operation status of each unit.
- (2) The energy used by outdoor units is apportioned to indoor units according to the usage ability of the indoor unit and the total energy used by each indoor unit is calculated for each refrigerant system.

6.2 Charge calculation processing

This processing calculates the electricity charge for the period of each block based on the bill from the electric power company.

(1) Basic and additional charges

- Apportioned to each block in accordance with the selected apportionment method.
- Apportionment is performed in day units.
- Apportioned between real blocks.
- Not apportioned to common blocks.
- Since charges are not distributed when there are no real blocks, when using basic and additional charges, set an owner block, etc. so that blank period blocks are not generated.

(2) Meter rate charges

- The total energy used by each indoor unit calculated by fixed period processing is accumulated through the calculation period as the total energy used by each block. Indoor units not allocated to a block are integrated as an undefined block.
- Meter rate charges are apportioned to each block in accordance with the proportion of the calculated total energy used by each block.

(3) Common block

- The result of accumulation of meter rate charges above becomes the source of apportionment for common blocks.
- Charges are apportioned to blocks specified as distribution destinations in accordance with the selected apportionment method.
- Apportionment is performed in day units
- Apportionment is apportioned among real blocks.
- The period when there are no real blocks is integrated at undefined blocks.

7. Cases for which Undefined Blocks are Generated

Cases for which undefined blocks are generated and measures to be taken when you do not want the undefined blocks to be generated, are described below.

(1) When there is an R/C group which belongs to a contract, but is not allocated to a block, its power consumption is apportioned to an undefined block.

To prevent generation of an undefined block

- Allocate all R/C groups to blocks.
- When that is not possible, either allocate it to a common block, or power off the indoor unit and perform re-scan so that it is removed from the electricity charge apportionment object.

(2) When the electricity charges of a common block are to be freely distributed to tenant blocks and the total is not 100%, the power consumption under 100% is apportioned to an undefined block.

- To prevent generation of an undefined block, make sure that the total distributed power consumption is 100%. In addition, when the period of the allocated blocks do not match, an undefined block is generated for periods that do not match.

(3) On the day with no block defined, with just common blocks or with blocks but when some units remain unallocated, those energy consumption are apportioned to undefined blocks.

- To prevent generation of an undefined block, disable the electricity charge apportionment function during that period.

8. Electricity charge apportionment error

Errors and their main causes related to electricity charge apportionment detected by the System Controller are described.

(1) Generation conditions

- Generated when a unit that does not send the information necessary for electricity charge apportionment (non-communicating unit) is detected during the period electricity charge apportionment data collection is performed.

Judgment, performed for the outdoor unit and the indoor unit, is based on whether there is no communication for more than 30 minutes or not.

(2) Processing of errors by the System Controller

- Electricity charge apportionment error with the unit address are displayed for the non-communicating unit.
The generation time and recovery time are recorded in the error history as with the other errors.
- In the electricity charge apportionment calculation, non-communicating unit is handled as follows:
 - Non-communicating indoor unit: Handled the same as an indoor unit whose operation is stopped by a remote controller
 - Non-communicating outdoor unit: When the non-communicating unit is a master unit, since the minimum data necessary for electricity charge apportionment is not collected, apportionment calculation of the relevant refrigerant system is not performed. (Charge becomes "0".) When a slave unit is the non-communicating unit, calculation is performed as if the slave unit does not exist.
- Whether or not the outdoor unit standby power is apportioned to non-communicating indoor units can be set from the basic setting screen.

(3) Recovery conditions

- When the data necessary for electricity charge apportionment can be acquired from the relevant unit, the electricity charge apportionment error is reset.

(4) Main error generation causes

- Electricity charge apportionment errors are mainly generated when the power breaker of a unit is switched off.

(Because apportionment data is not sent when the power breaker is switched off.)

When the power breaker of only part of the units in a refrigerant system is switched off, outdoor unit trouble may occur.

Therefore, if there is a unit whose power breaker is switched off, quickly recover the power by switching on the breaker.

9-2 Electricity charge apportionment main screen

Performs electricity charge apportionment setting.

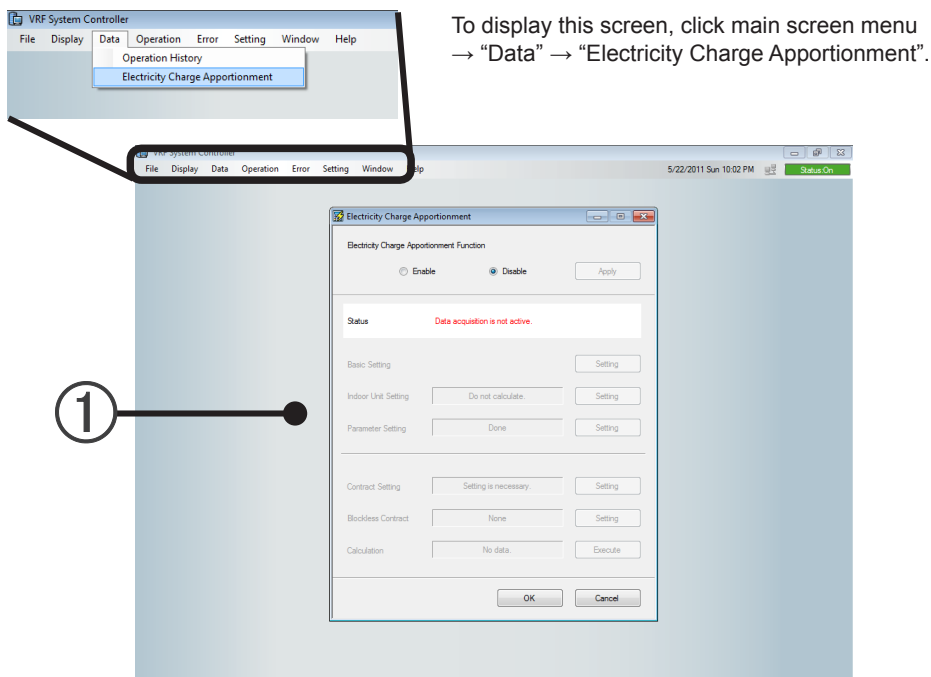

To display this screen, click main screen menu → “Data” → “Electricity Charge Apportionment”.

- ① Electricity charge apportionment main screen
(The screen is in the unset state. The contents which can be selected vary depending on the setting)

■ Function lock

Only the user that started the electricity charge apportionment main screen for the first time can use the electricity charge apportionment function.

If another user attempts to open the electricity charge apportionment main screen while the electricity charge apportionment function is being used, the message shown below is displayed.

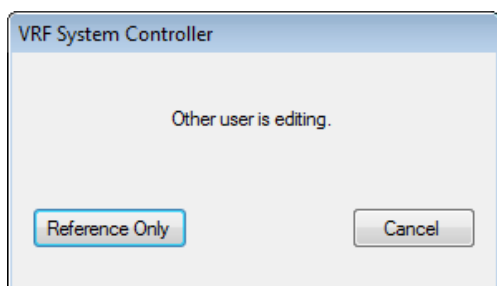

[Reference Only]

Displays the electricity charge apportionment main screen in the locked state. (Only the [OK] button is enabled)

[Cancel]

Ends the electricity charge apportionment function without displaying the electricity apportionment main screen.

Note

When performing electricity charge apportionment setting by remote connection, required time varies depending on the network communication speed. To avoid this, perform electricity charge apportionment setting on server PC preferably.

9-2-1 Main screen

The screen is for description purposes.

The contents which can be selected vary depending on the setting.

You cannot calculate the start day of data collection.

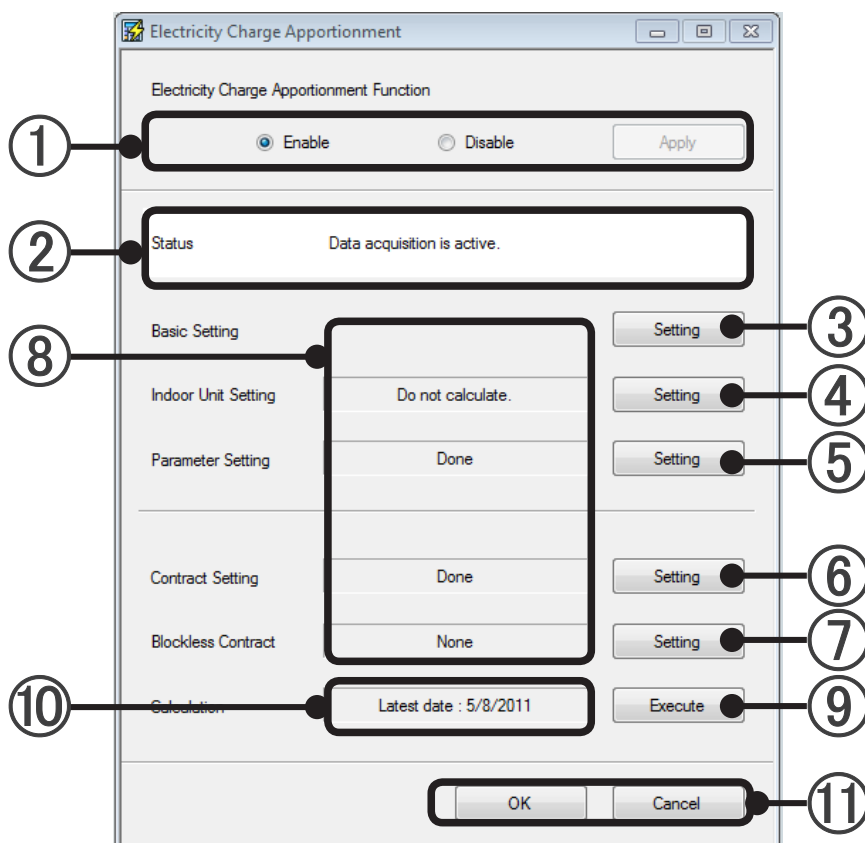

- ① Selects whether or not electric charge apportionment is to be performed and is entered by [Apply] button.
- ② Displays the data acquisition state. If "Data acquisition is active." is displayed, data acquisition is performed normally.
If ④ to ⑥ are not set correctly, "Data acquisition is not active." is displayed in red.
In this case, data acquisition are not performed and apportionment calculation cannot be performed.
- ③ Basic setting
Overall setting is performed at electricity charge apportionment calculation. (For details, see par. 9-3.)

- ④ Sets whether or not the power consumption of indoor units is included in electricity charge apportionment calculation. (For details, see par. 9-4.)
- Display contents of ⑧ “Calculate for all units”: Includes the power of all indoor units in apportionment calculation.
- “Do not calculate”: Does not include the power of all indoor units in apportionment calculation.
- “Custom setting”: Includes the power of some indoor units in apportionment calculation.
- ⑤ Sets the parameters of each unit. (For details, see par. 9-5.)
- Display contents of ⑧ “Done”: Ends parameter setting of all units.
- “Setting is necessary”: There is a unit which whose parameters cannot be set.
- ⑥ Performs contract setting. (For details, see par. 9-6.)
- Display contents of ⑧ “Done”: Ends contract setting.
- “Setting is necessary”: There are no contract settings or there is a contract without a unit.
- ⑦ Performs block setting. (For details, see par. 9-7.)
- Display contents of ⑧ “Done”: Ends block setting at all contracts.
- Display other than this displays the number of contracts without set blocks.
- ⑧ The current state of settings ④ to ⑦ is displayed.
- ⑨ Performs electricity charge apportionment calculation. Apportionment Calculation screen opens. (For details, see par. 22-2-1.)
- ⑩ The latest date for which calculation is possible is displayed.
- ⑪ [OK]: Saves the edited contents and ends setting.
[Cancel]: Ends setting without saving the edited contents.
- However, when the [OK] button is clicked in each setting screen at ④ to ⑦ and ⑨, the edited contents cannot be canceled.

9-3 Basic Setting

Sets whether or not outdoor unit standby power is apportioned to non-communicating indoor units.

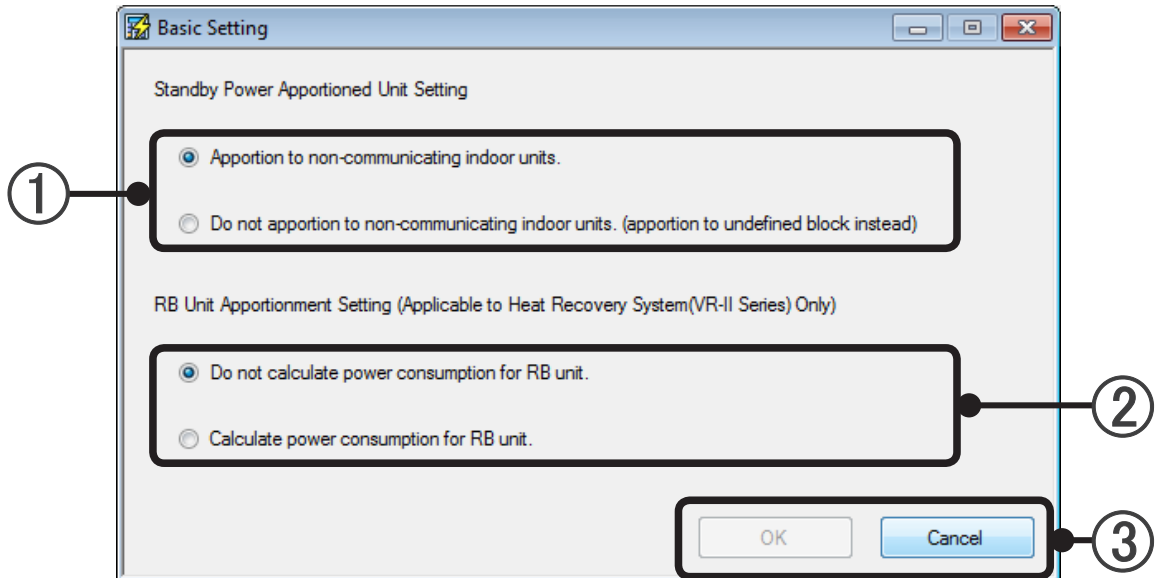

- ① Set whether or not the outdoor unit standby power is to be apportioned to non-communicating indoor units.
 - Apportion to non-communicating indoor units
Standby power is apportioned even to non-communicating indoor units
 - Do not apportion to non-communicating indoor units.(apportion to undefined block instead)
Outdoor unit standby power is not apportioned to non-communicating indoor units.
(Standby power not apportioned to non-communicating indoor units is apportioned to the owner block (Undefined Block).)
- ② Set the apportioning method of RB unit.
 - Do not calculate RB Unit's power consumption.
The calculation of RB unit is not performed.
 - Calculate RB Unit's power consumption
The calculation of RB unit is performed.
- ③ [OK]: Saves the edited contents and ends setting.
[Cancel]: Ends setting without saving the edited contents.

Note

When system controller and outdoor unit cannot communicate due to tripping of a unit power breaker or a network error, since the minimum data needed for apportionment calculation cannot be acquired, electricity charge apportionment calculation is not performed.

9-4 Indoor unit electricity calculation setting

To display this screen, click the [Setting] button of the “Indoor Unit Setting” item on the electricity charge apportionment main screen.

Whether or not the electricity charge of indoor units is included in calculation is decided by this screen.

Description of Indoor Unit Setting

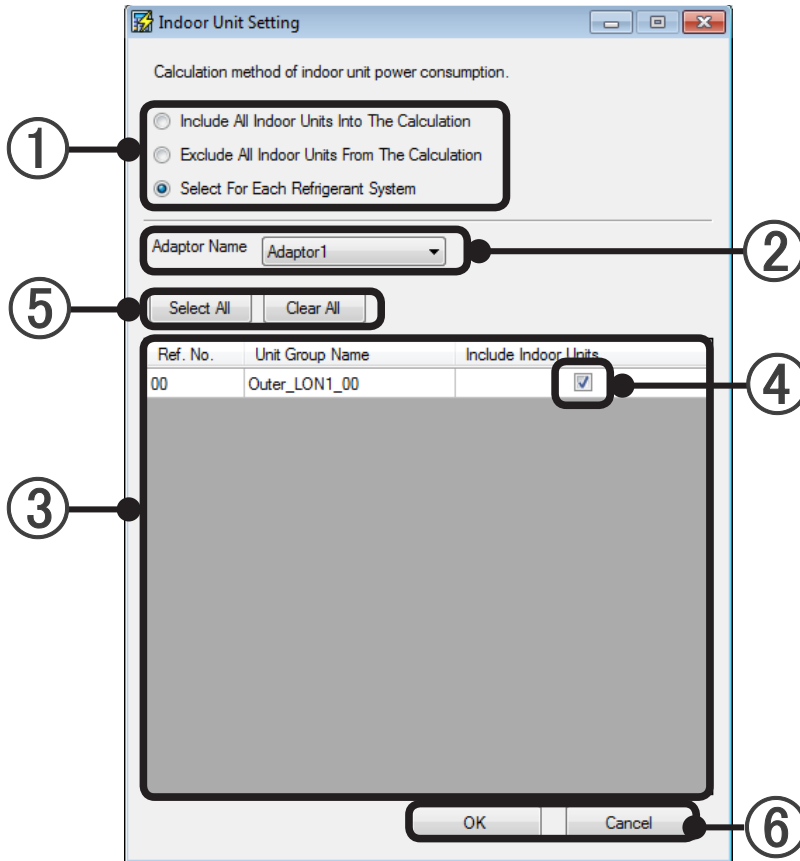

① Selects the indoor unit calculation type.

“Include All Indoor Units Into The Calculation.”	The electricity charge of indoor units is also included in calculation. Select when the power meter is shared by the indoor unit and outdoor unit power source and when the power meter of the same contract destination as an outdoor unit is installed at an indoor unit power source. (Settings ② to ⑤ cannot be performed.)
“Exclude All Indoor Units From The Calculation.”	The indoor unit electricity charge is not included in calculation. Select when a power meter independently contracted with the electric power company by tenants is installed at the indoor unit power source, etc. (Settings ② to ⑤ cannot be performed.)
“Select For Each Refrigerant System”	Select when setting whether or not indoor unit power consumption is included in calculation for each refrigerant system.

Select according to the power meter position and contact with the electric power company.

Note

If a setting is changed during data acquisition, the results of calculation after setting will also change.

When “Select For Each Refrigerant System” is selected at ①, set items ② to ⑤.

- ② Selects the adaptor (U10 USB Network Interface) which is to perform setting by pull-down menu.
- ③ Displays a list of the refrigerant systems connected to the adaptor selected at ②.
- ④ Selects whether or not indoor units are included individually for each refrigerant system by checkbox.
- ⑤ When clicked, [Select All] or [Clear All] of ④ is checked.
This is convenient when starting from the highest number when selecting the refrigerant systems individually at ④. Reflected by range (adaptor units) displayed at ③.
- ⑥ [OK]: Saves the edited contents and ends setting.
[Cancel]: Ends setting without saving the edited contents.

Note

- When setting is finished with [Select All] or [Clear All] checked at ⑤, the setting of ① becomes “Include All Indoor Units From The Calculation.” or “Exclude All Indoor Units From The Calculation.”
- When the power meter or other contract contents were changed by resident or tenant updating, change the setting at the same time.

9-5 Parameter setting

To display this screen, click the [Setting] button of the “Parameter Setting” item on the electricity charge apportionment main screen.

Setting of the model name of the unit which is to perform electricity charge apportionment calculation and the externally linked devices are performed by means of this screen.

Since model name setting is necessary in electricity charge apportionment calculation, perform it certainly. (Normally, if scanning is performed, the model name is set automatically.)

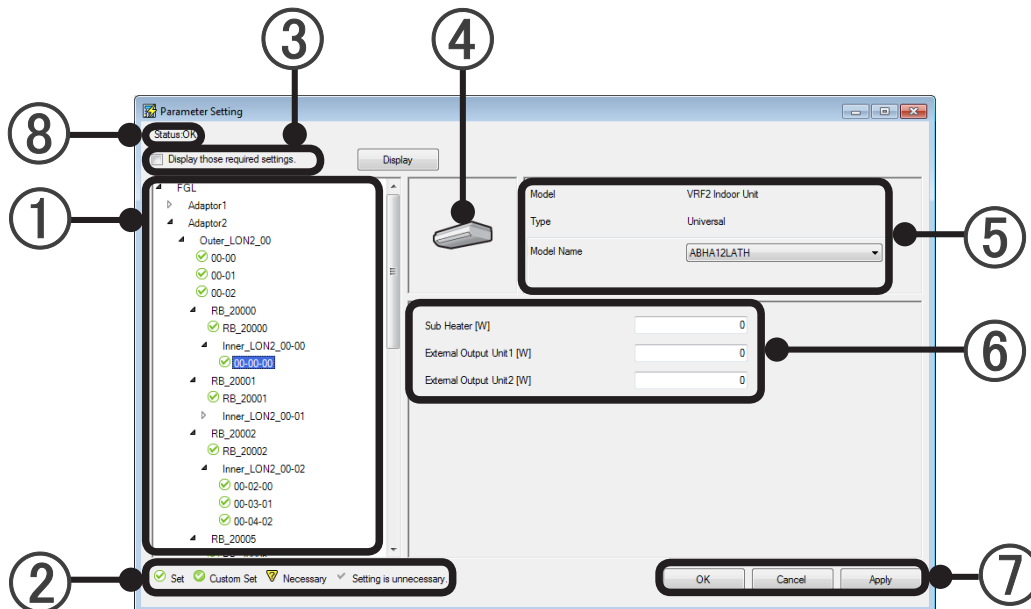



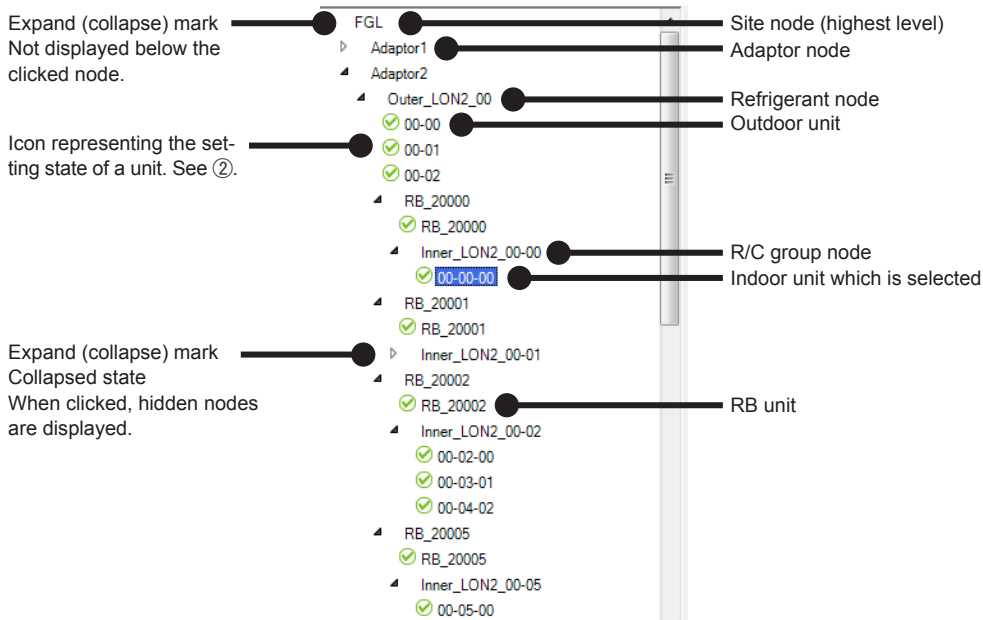

- 1 Selects the unit (outdoor unit, indoor unit, RB unit) which is to be set from the list hierarchically displayed in tree view site, adaptor, refrigerant, and R/C group order.



Note

The “Tree View” may not be displayed on the screen depending on the contents. In this case, display it by scrolling the screen using the scroll bar at the side of the screen.

② Description of icons representing the setting state of the units in the “Tree View”.

 Set	V-II/J-II/VR-II Series unit set without externally linked devices
 Custom Set	V-II/J-II/VR-II Series unit set with externally linked devices
 Necessary	V-II/J-II/VR-II Series Unit whose parameter is unclear. When you install a new unit and replace the board, it may be incompatible with the version of system controller. When this icon is displayed, electricity charge apportionment calculation is performed without ending setting. Please contact your dealer.
 Setting is unnecessary	S Series or V Series unit (Setting is unnecessary)

③ Refinement

Display only those units for which parameters have not been set.

Once all unit settings have been configured, the unit name will no longer be displayed.

④ Displays the “unit icon”

⑤ Displays the Model, type, and model name of the Unit.

When the model name is displayed in red bold characters, it is a model which is not compatible with the system controller. Please contact your dealer.

In the case of RB unit, type is not displayed.

⑥ Sets the power consumption of auxiliary heater, ventilation fan, or other linked device added to the unit in watt. hr. (within 7 digits, integer number only) Manual setting at all relevant units is necessary. (Except the automatic setting objective at scanning.)

Example of outdoor unit display

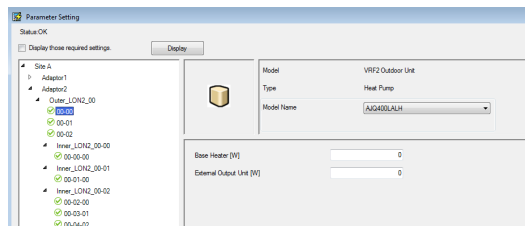

Example of indoor unit display

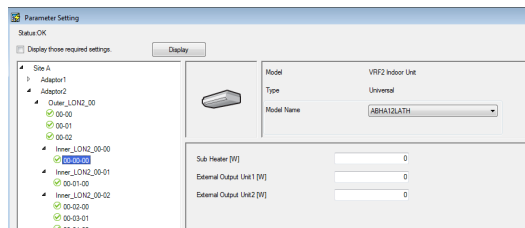

Example of RB unit display

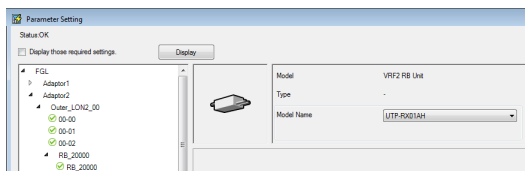

- ⑦ [OK]: Saves the edited contents and ends setting.
[Cancel]: Ends setting without saving the edited contents.
(When [Apply] was performed during work, it cannot be canceled by [Cancel].)
[Apply]: Saves the edited contents without ending setting.
- ⑧ Displays whether setting are done for all units.
Status: OK - setting are done for all units.
Status: Necessary - Some units still need to be set parameters.

Note

- Except for indoor- and outdoor-units, items cannot be displayed in Tree View.
- If not even one indoor unit or outdoor unit is connected, there may be a display at ① Tree View, but setting is unnecessary.
- When a unit was added or replaced, quickly perform scanning and end unit registration and parameter setting.
- Even if the model name has been set, it will not be reflected in the unit list. Model name setting uses the electricity charge apportionment parameter.

9-6 Contract setting

Overview of contract

- Performs data acquisition at which the scan unit becomes the apportionment objective.
- Create a contract for each bill (bill for which you want to apportion) from the electric power company.
- Create blocks (become the bill output unit of the apportionment function) in the contract.
- 1 refrigerant system cannot be set to span multiple contracts.

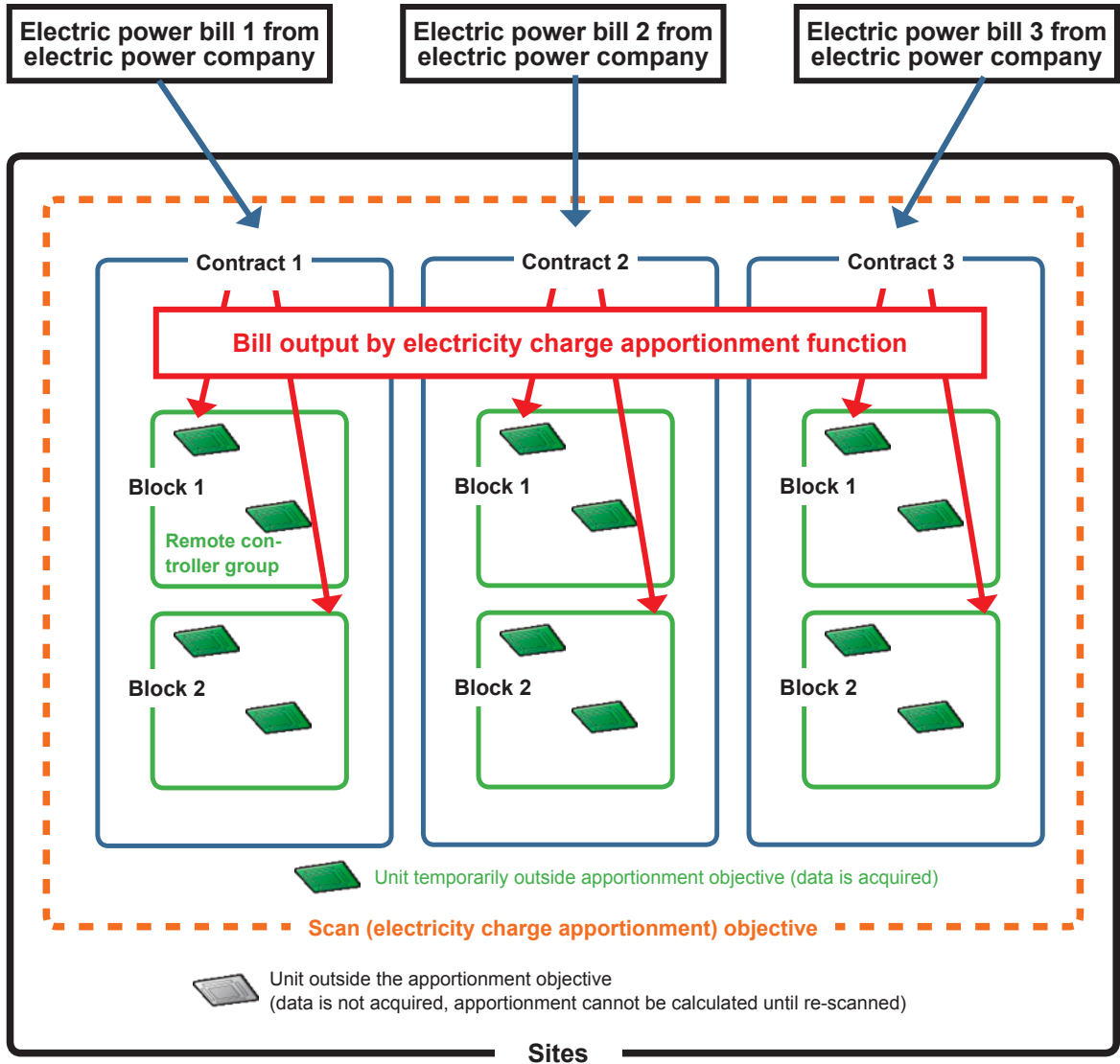

9-6-1 Contract list creation

To display this screen, click the [Setting] button of the “Contract Setting” item on the electricity charge apportionment main screen.

Contracts equaling the number of contracts (number of bills) with the electric power company are created at this screen. Apportionment calculation is performed for each of the contracts created here.

Description of Contract List screen

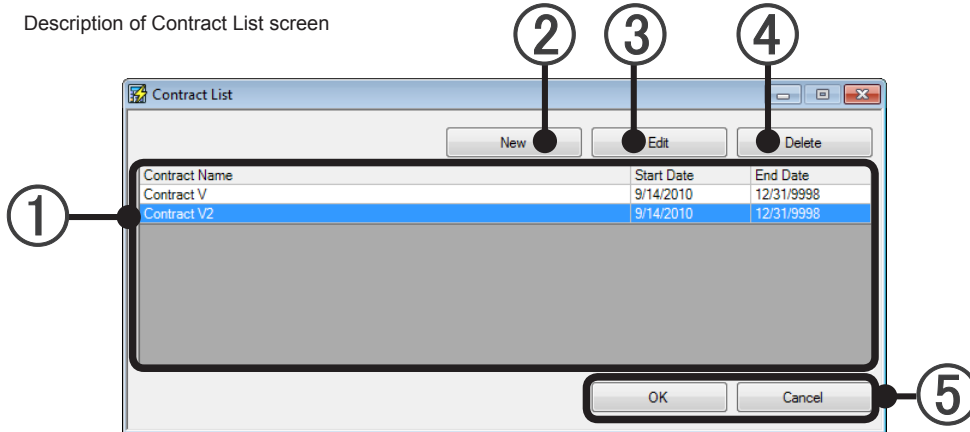

- ① Lists set contracts and contract periods.
- ② Creates and adds new contract setting. (See par. 9-6-2.)
- ③ Changes the contract setting selected at ①. (See par. 9-6-2.)
- ④ Deletes the contract setting selected at ①.
Block settings in this contract are simultaneously deleted.
- ⑤ [OK]: Saves the edited contents and ends setting.
[Cancel]: Ends setting without saving the edited contents.

9-6-2 New contract creation and editing

Performs setting for each contract created at par. 9-6-1.

To display this screen, click the [New] button or [Edit] button at par. 9-6-1 Contract list creation.

Description of contact setting screen

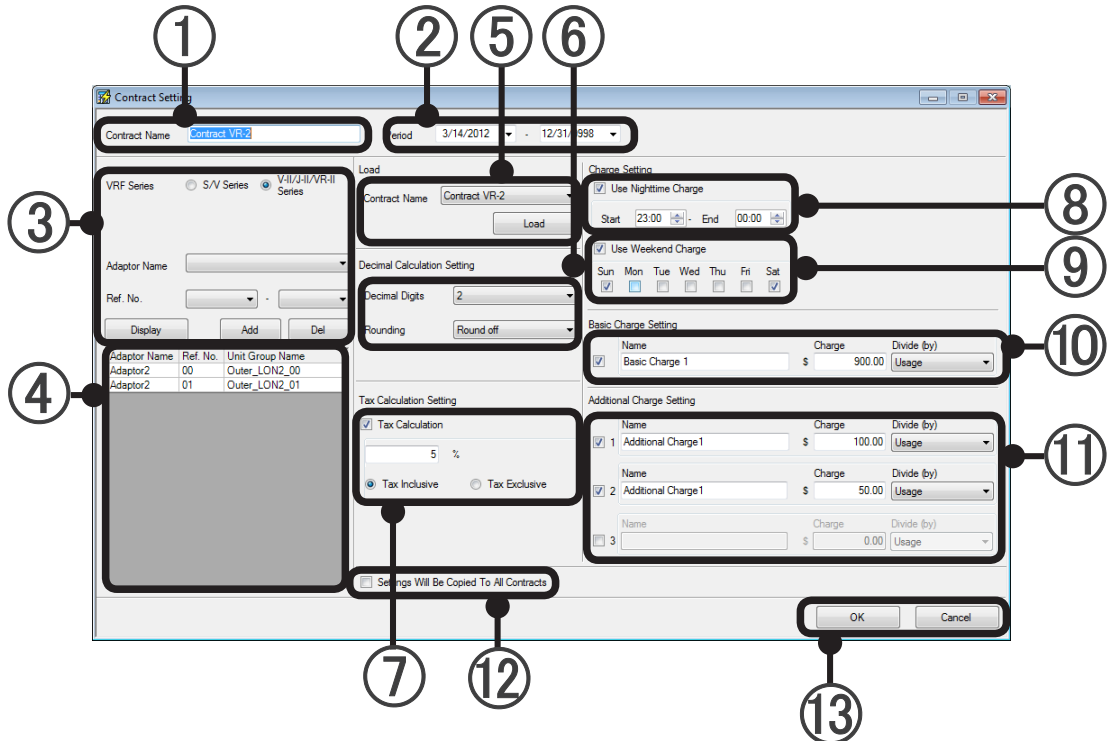

- ① Inputs and edits the name of the contract. (Within 20 characters of alphabet, numeric, and symbol)
- ② Contract start and end dates setting. (Calendar is opened by pull-down menu. Key input is also possible.) After setting, the refrigerant systems which can be selected during this period at ③ are updated by clicking the [Display] button of ③.
- ③ Refrigerant system setting and change
 1. Select the contract system type.
 2. Select the objective adaptor (U10 USB Network Interface).
 3. Select the refrigerant system range by pull-down menu. (Cannot be selected when all systems were set.)
 4. When the [Add] button is clicked, the refrigerant systems are displayed in the list at ④.

Deleting refrigerant system from setting

1. Select the refrigerant system to be deleted at the list of ④.
2. Click the [Del] button.

Redisplaying the refrigerant systems

1. Since the refrigerant systems which can be selected at ③ are updated when [Display] is clicked when the contract period was changed at ②, reset the refrigerant systems.

- ④ List of refrigerant systems set at the contract.

- ⑤ The contents of items ⑥ to ⑪ can be used in contracts which have already been set.
Select the contract name to be referenced by pull-down menu and load it using the [Load] button.
- ⑥ Sets the number of display digits after the decimal point. (Calculation is performed at this setting.)
- Number of digits after the decimal point which is displayed. Select by pull-down menu. (0 to 5)
 - Method of rounding of fractions below the display. Select by pull-down menu. (Round off, count fractions as one, truncate)
- ⑦ Tax calculation setting. Enabled when checkbox is checked.
Input the tax rate at the text box. (0~99.99)
Selects whether the amount of the calculated result is to be handle “Tax inclusive” or “tax exclusive”.
When the billed amount includes the tax, select “Tax inclusive” and when the tax is separate, select “Tax exclusive”.
- ⑧ Nighttime charge setting. Set when the electricity charge unit price is different in the daytime and at nighttime.
Enabled when checkbox is checked.
Set the start time and end time of the time frame corresponding to nighttime charge. (Set in 30 minutes units and evening of current day to morning of next day)
- ⑨ Weekend charge setting. Set when the electricity charge unit price is different on weekdays and weekends.
Enabled when checkbox is checked.
Select the day of week corresponding to weekend charge. (Multiple days can be selected)
- ⑩ Basic charge setting. Enabled when checkbox is checked.
“Name”: An arbitrary name can be set. (Within 20 characters of alphabet, numeric, and symbol)
“Charge”: Inputs the basic charge. (Numeric only within 11 digits. Can be changed during calculation)
* Input up to the number of digits after the decimal point set at ⑥.
“Divide”: Select the charge distribution method by pull-down menu
(Equal distribution, distribution according to number of units, distribution by amount of electricity used, distribution according to total indoor unit capacity)
- ⑪ Additional charge setting. Up to 3 additional charges can be set. Enabled when checkbox is checked.
Perform input sequentially, beginning from additional charge 1.
“Name”: An arbitrary name can be set. (Within 20 characters of alphabet, numeric, and symbol)
“Charge”: Inputs the additional charge. (Numeric only within 11 digits. Can be changed during calculation)
* Input up to the number of digits after the decimal point set at ⑥.
“Divide”: Select the additional charge distribution method by pull-down menu
(Equal distribution, distribution according to number of units, distribution by amount of electricity used, distribution according to total indoor unit capacity)
- ⑫ When checked and [OK] is clicked, items ⑥ to ⑪ are made the same setting for all the contracts.
- ⑬ [OK]: Saves the edited contents and ends setting.
[Cancel]: Ends setting without saving the edited contents.

Note

At contract addition, change or end, end setting up to the relevant date.
If changes are made later, correct calculation will not be performed.
You cannot calculate the start day of data collection.
Set Basic Charge to the basic amount charged by the electricity company, if there is a basic charge.
If there is no basic charge, you do not need to set this.

9-7 Block setting

9-7-1 Block schedule setting

To display this screen, click the [Setting] button of the “Block less contract” item on the electric charge apportionment main screen.

Setting of the move-in/move-out schedule of supposed tenant blocks is performed for each contract. Common blocks can also be set.

Description of screen

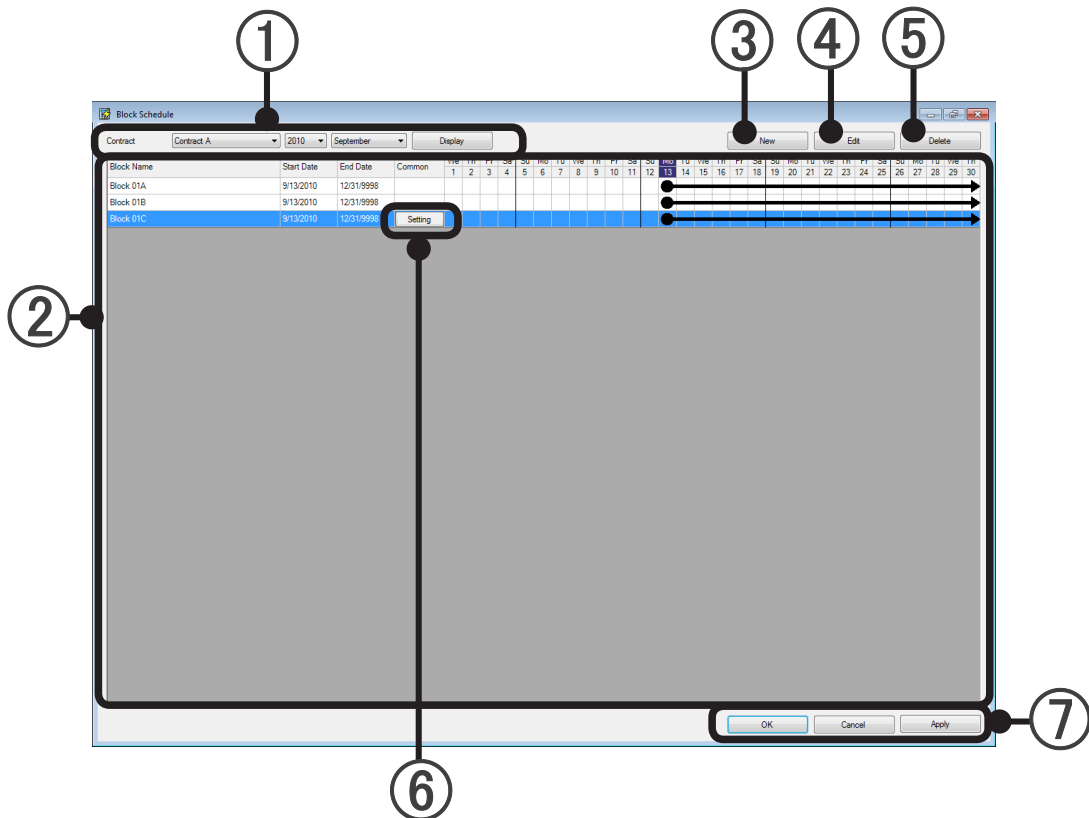

- ① Selects the contract name, year, and month to be displayed.
When the [Display] button is clicked, the blocks set at ② are displayed.
- ② The block setting state of the contents selected at ① is displayed. The block setting period is represented on the calendar by a line.
 - When the block setting period spans the previous month and the next month or more
 - When the block setting period starts from in the displayed month
 - When the block setting period ends in the displayed month
(Units of periods not belonging to a block are attributed to an “Undefine” block.)

Note

The calendar display of ② may not appear on the screen depending on the number of set blocks and the PC monitor size.

In this case, display it by scrolling the screen with the scroll bar at the end of the screen.

- ③ New block creation button. (See par. 9-7-2.)
Creates a new block. When the [New] button is clicked, the “Specify Block” screen opens. The created blocks are displayed at ②.
- ④ Block edit button. (See par. 9-7-2.)
Edits the setting contents of the block. When the [Edit] button is clicked after a block is selected at ②, the “Specify Block” screen opens.
- ⑤ Block delete button.
Deletes the block. When the [Delete] button is clicked after a block is selected at ②, that block is deleted.
- ⑥ Common block [setting] button.
(See par 9-7-2. Displayed when set to common block at the “Specify block” screen.)
When clicked, the “Common Specify Block” screen opens. Always set when there is a common block.
(If common block setting is not complete, correct calculation cannot be performed.)
* Perform common block setting after creating all the tenant blocks.
- ⑦ [OK]: Saves the setting and ends it.
[Cancel]: Ends the setting without saving it.
(When [Apply] was performed during work, it cannot be canceled by [Cancel].)
[Apply]: Saves the block schedule setting without ending it.

Note

When a new contract was created and when a block (resident or tenant) was updated, end setting before the block period starts.
In addition, when the block period end date was decided, end setting before the end date.

9-7-2 Specify Block screen

To display this screen, click the [New] button or the [Edit] button of the par. 9-7-1 “Block schedule setting” screen.

Creates a new block or edits an existing block. Registers and edits R/C groups belonging to the block.

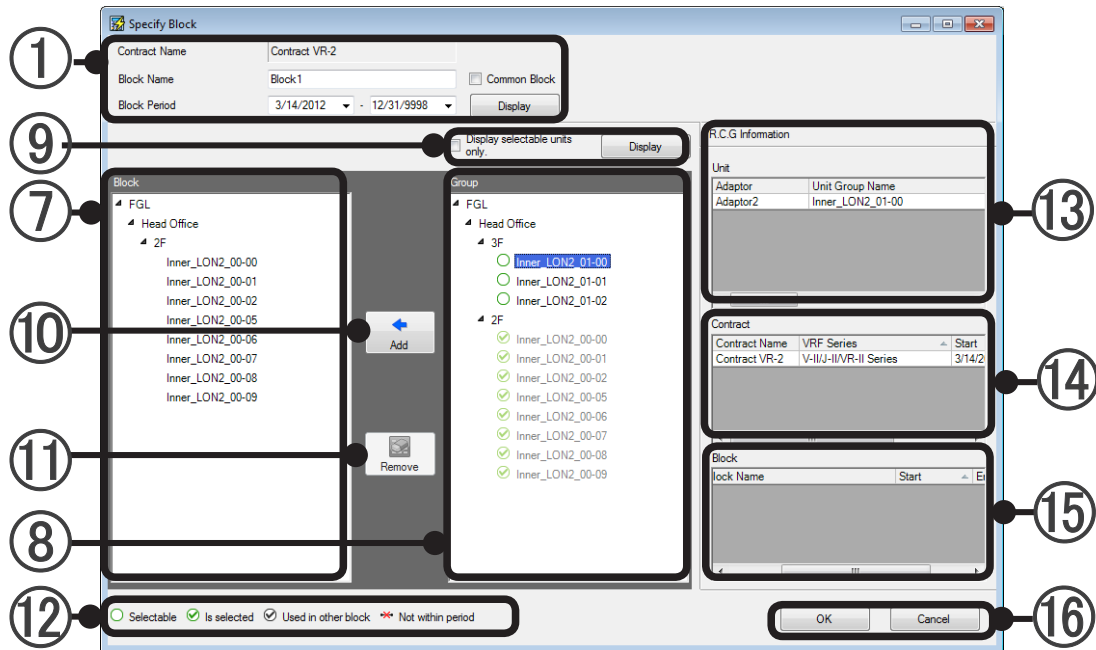

① Block basic setting

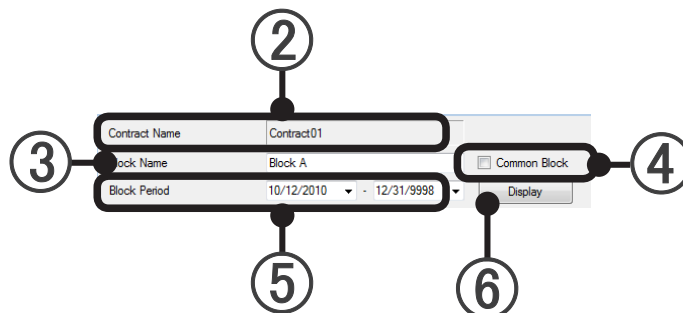

- ② Contract name: Displays the name of the contract to which the block belongs.
- ③ Block name setting:
An arbitrary name can be text input. (Within 20 characters of alphabet, numeric, and symbol)
- ④ Common setting:
Can be set as a common block. Enabled by checking the checkbox. The [Setting] button at the block schedule setting screen is enabled.
- ⑤ Block period setting:
Sets the start and end dates of the objective period of the block. Can be set by key input or from the calendar displayed by pull-down menu. Setting within the contract period is possible.
- ⑥ [Display] button: When clicked, the setting state for the period specified at ⑤ is displayed at ⑦ and ⑧.
- ⑦ Block list:
Tree view of the R/C groups registered at the block being set.

- ⑧ Group list:
Tree view of the R/C groups by group. R/C groups not set at a group are displayed as “Undefined” Group.
Registered R/C groups are displayed in gray and cannot be set.
* R/C groups without electricity charge apportionment function are not displayed.

- ⑨ Refinement button
Display only those units for which parameters have not been set.

- ⑩ [Add] button
Registers the R/C groups and groups selected at ⑧ group list at the block of ⑦.

- ⑪ [Remove] button
Deletes the R/C group and group set at a block at ⑦.

- ⑫ Description of icon displayed at 8. Represents the state of the unit.

<input type="radio"/> Selectable	R/C group which can be registered
<input checked="" type="checkbox"/> Is selected	R/C group already registered at the block being set
<input checked="" type="checkbox"/> Used in other block	R/C group already registered at another block
<input checked="" type="checkbox"/> Not within period	Unit that does not exist within the period specified by ⑤

- ⑬ Unit information: Displays the “Adaptor”, “Unit Group Name”, “Address”, “Unit Type”, “Operation Start Date”, “Operation End Date”, “Model Name*”, “System Type (Cooling Only, Heat Pump, etc)”, and “Model” of the R/C group selected at ⑧.

*The letter “.” as the last letter of the Model Name signifies that the Model Name for the corresponding unit was written after shipment. The letter “.” is not part of the Model Name.

- ⑭ Contract information: Displays the “contract name”, “VRF Series name”, “contract start date”, and “contract end date” of the R/C group selected at ⑧.

- ⑮ Block information: Displays the “contract name”, “block name”, “block start date”, and “block end date” of the R/C group selected at ⑧.

- ⑯ [OK]: Saves the setting and ends it.
[Cancel]: Ends the setting without saving it.

New block setting flow

1. Contract name confirmation. Block name and period setting.

When registering the block as a common block, check “Common Block”.
Reflect the setting on the screen by clicking the [Display] button.

2. Select the R/C group to be registered at the block from the ⑧“Group” list. When the ⑨[Add] button is clicked, the R/C group is registered at the ⑦ “Block” list.

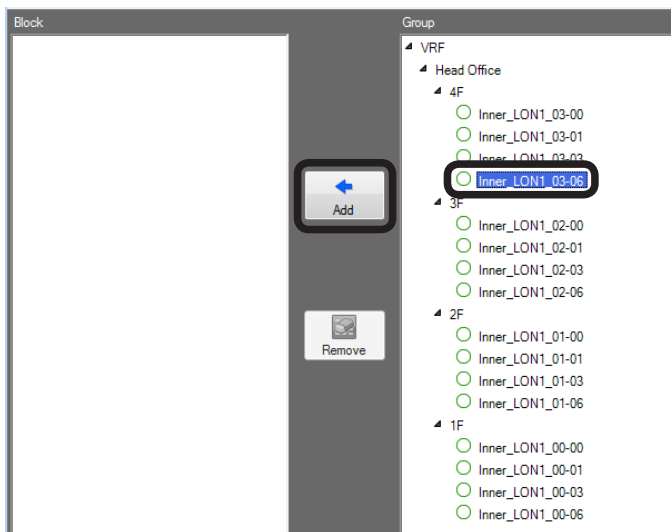

3. The R/C group registered at the block is displayed in the ⑦ “Block” list and becomes the registered display by ⑧“Group” list.

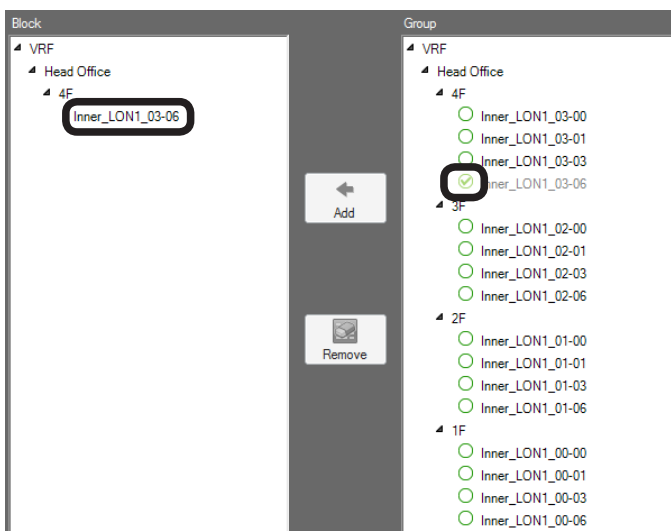

4. To delete an R/C group from a block, select the R/C group to be deleted from the ⑦ “Block” list and click the ⑩[Remove] button.

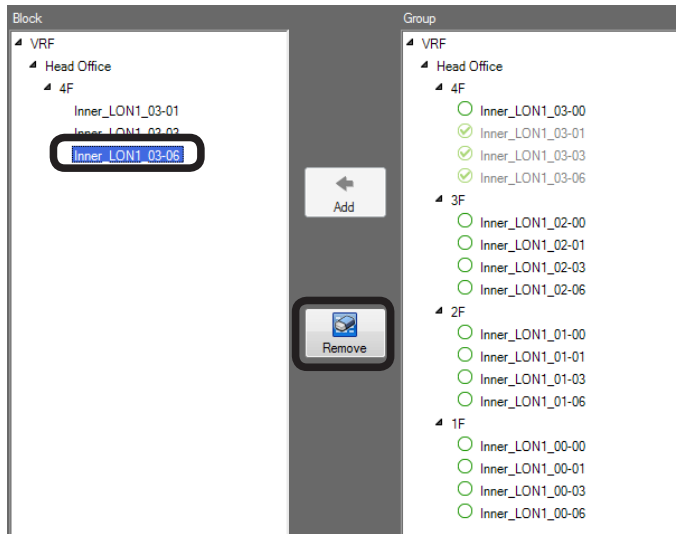

5. The selected R/C group is deleted from the block and can be selected at the ⑧ “Group” list.

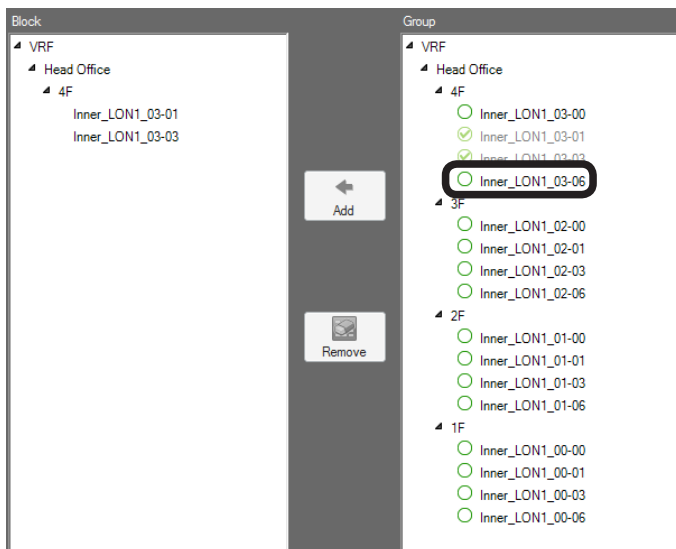

6. After registration is complete, end setting by clicking the [OK] button. To end by canceling the setting, click the [Cancel] button.

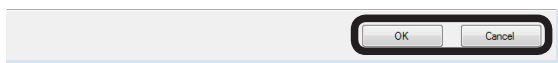

Note

To register each building and floor which already has the units laid out to a block, select the relevant building name or floor name from the ⑧ “Group” list and click the ⑨ [Add] button.

9-7-3 Common block setting

Sets the block with Common Block ④ checked at par. 9-7-2 Specify Block screen.

To display this screen, click the ⑥ Common block [setting] button of par. 9-7-1 Block schedule setting.

Sets the method the power consumed by common blocks is apportioned to tenant blocks.

Description of screen

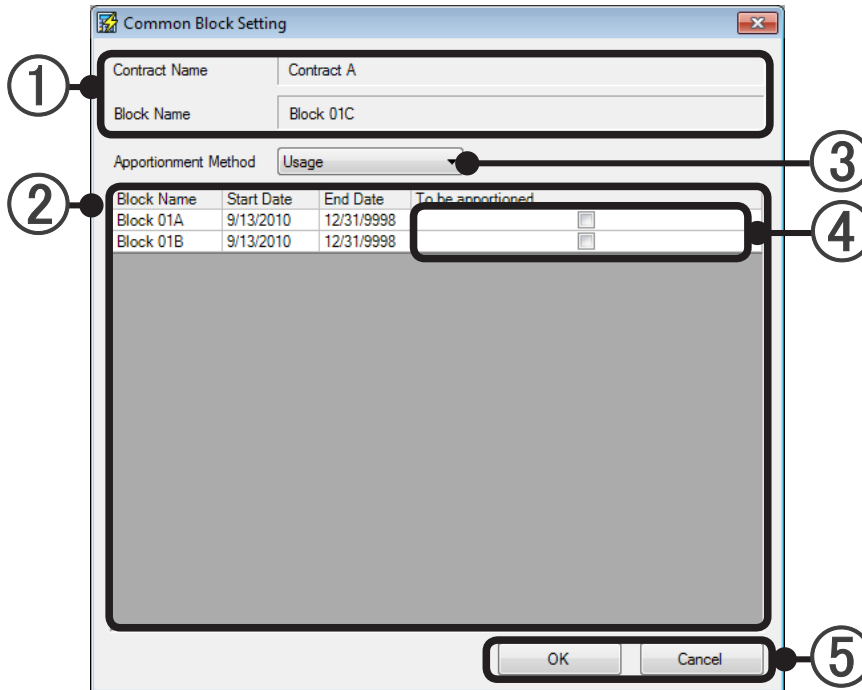

- ① Confirms the contract name and block name.
- ② Displays the block name and period of tenant blocks in the same contract as a common block in a list.
- ③ Selects the apportionment method by pull-down menu. See the block apportioned at ④.

“Equally”: Apportion equally to the selected blocks

“Unit quantity”: Apportion by proportion of number of units

“Usage”: Apportion by proportion of amount of power used (metering) (Recommended)

“Capacity”: Apportion by allowable capacity of unit

Set by checkbox.

“Manually”: Apportion by arbitrary setting.— Manual setting of apportionment ratio. In the initial state at selection, 100% of the consumed power is apportioned to “Undefine” blocks as imaginary blocks and displayed. Since key input is possible at field (4), adjust so that the total apportionment ratio to the tenant block is 100%. If an apportionment ratio to an “Undefine” block remains, the “Undefine” block will be charged at apportionment calculation.

- ⑤ [OK]: Saves the setting and ends it.
- [Cancel]: Ends the setting without saving it.

Note

After all settings are finished, electricity charge apportionment data acquisition is started. Close the “Electricity Charge Apportionment” screen (par. 9-2-1). When performing electricity charge apportionment calculation, see par. 22. Electricity charge apportionment.

10. Error E-mail Notification Setting

Automatically sends an error notification e-mail to the preset e-mail address whenever an error occurs.

10-1 E-mail Setting screen

To display this screen, select the main screen menu → “Setting” → “Mail setting”

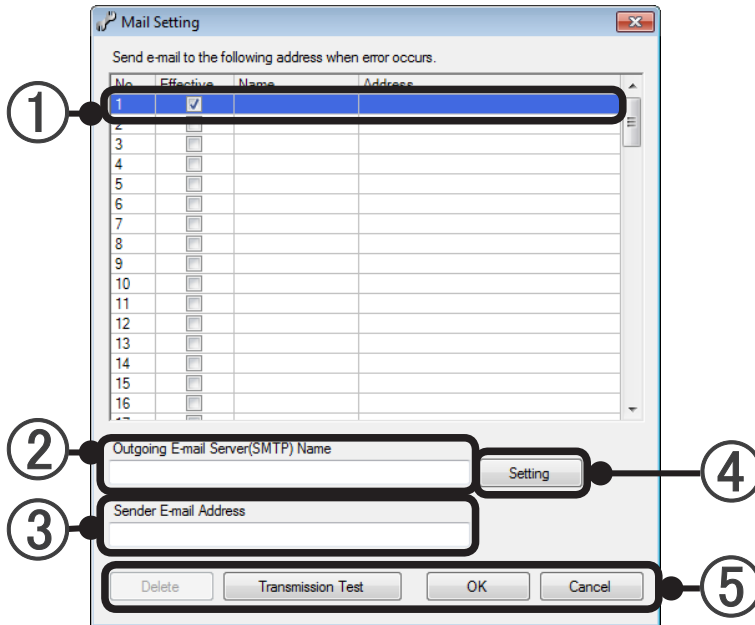

- ① Enters the receiver's name and E-mail address. (Up to 100 names and addresses can be registered)
“No.”: Line numbers from 1 to 100 are displayed.
“Effective”: When checked, enables setting of that line.
* When “Effective” is unchecked, an e-mail is not sent.
“Name”: Enters the receiver's name. (Within 20 characters of alphabet, numeric, and symbol)
“Address”: Enters the receiver's e-mail address.
(Within 50 characters of alphabet, numeric, and symbol)
- ② Enters the SMTP server name for e-mail transmission.
(Within 50 characters of alphabet, numeric, and symbol)
* The SMTP service name differs with the network environment. If the SMTP server name is unknown, check with the network administrator.
- ③ Enters the sender's e-mail address. (Within 50 characters of alphabet, numeric, and symbol)
- ④ Press [Setting] button to change to Out going mail server setting screen.
- ⑤ Closes the E-mail Setting screen after setting is complete.
[OK]: Saves the edited contents and ends setting.
[Cancel]: Ends setting without saving the edited contents.
[Delete]: Delete the selected item.
[Transmission Test]: Sends test by email. (Confirm that the email reached its destination.)

Note

Error E-mail transmission conditions

Errors are checked at 5 minute intervals and only errors being generated are sent.
However, errors that were sent and errors which were reset within 5 minutes are not sent.

10-2 Out going mail server setting

In the case that a authentication required mail server is used when a mail was sent, please set logon information.

Authentication method will be either "POP before SMTP" or SMTP authentication.

The screenshot shows a dialog box titled "Outgoing Mail Server" with a close button (X) in the top right corner. The dialog is divided into two sections: "Incoming Mail Server" and "Outgoing Mail Server".

- 1** points to the "Effective" checkbox.
- 2** points to the "Incoming Mail Server" radio button.
- 3** points to the "Incoming mail (POP3)" text input field.
- 4** points to the "Account name" text input field.
- 5** points to the "Password" text input field.
- 6** points to the "Outgoing Mail Server" radio button.
- 7** points to the "Port" spin box.
- 8** points to the "Account name" text input field.
- 9** points to the "Password" text input field.

At the bottom of the dialog are "OK" and "Cancel" buttons.

① Effective

With check: Authentication will act when a mail is sent.
Please set Incoming Mail Server or Outgoing Mail Server.
No check: Authentication will not act when a mail is sent.

② Incoming Mail Server

The mail is sent under the authentication method of "POP before SMTP"

③ Incoming mail(POP3):

Please input the name of incoming mail server.

④ Account name:

Please input the account name of incoming mail server.

⑤ Password:

Please input the password of incoming mail server.

⑥ Outgoing Mail Server

The mail is sent by SMTP authentication.

⑦ Port:

Please input the Port number of incoming mail server.(default: 25)

⑧ Account name:

Please input the account name of outgoing mail server.

⑨ Password:

Please input the password of outgoing mail server.

Note

POP before SMTP: It is a method to sent a mail after the authentication incoming mail server is acted before the mail is sent.

(Only System Controller login into incoming mail server, so the mail will not be received.)

SMTP authentication: It is a method of outgoing mail server authentication when sent a mail.

11. User Environment Setting

Performs setting related to VRF Explorer representation. The following settings are performed here.

“Alarm”: Alarm sound setting

“Unit”: Temperature units setting

“Screen size”: Status monitor (site/building/floor) display setting

To display this screen, select main screen menu → “File” → “Environment Setting”.

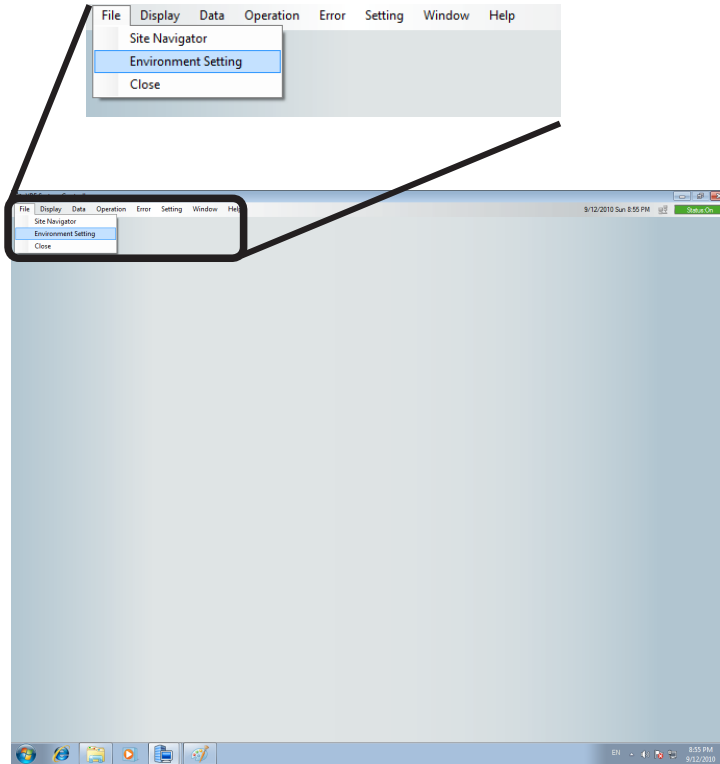

The environment setting screen opens. Advance to “Environment Setting” screen (par. 11-1).

Note

The settings made here become effective when the VRF Explorer main screen closed and then re-opened. After the end of setting, select main screen menu → “File” → “Close” and right click site icon and select “Detail” of the “Site Navigator” screen. (Selecting the site icon and clicking the tool icons “Detail” button is also possible.)

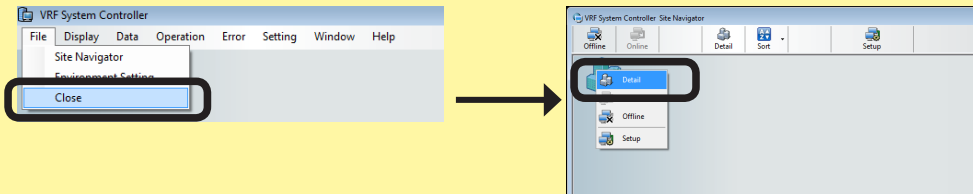

11-1 Environment Setting screen

Description of screen

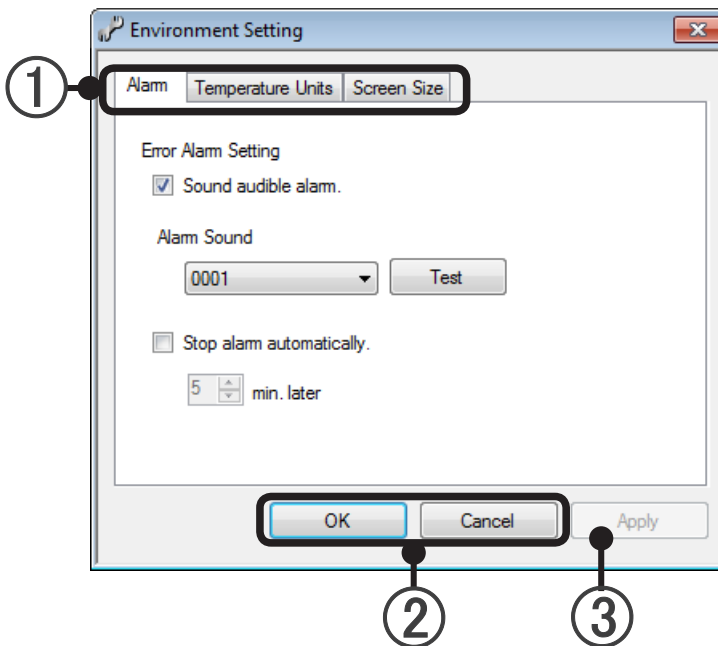

- ① Setting type tab: Switches the setting item.
- ② Closes the screen after the end of setting.
[OK]: Saves the edited contents and ends setting.
[Cancel]: Ends setting without saving the edited contents.
- ③ [Apply]: Saves the settings without closing the screen.
If there is even 1 setting, selection is possible.
* When [Apply] is clicked; it cannot be canceled by [Cancel].

11-1-1 Alarm sound setting

Performs setting related to the alarm sound when an error occurs.

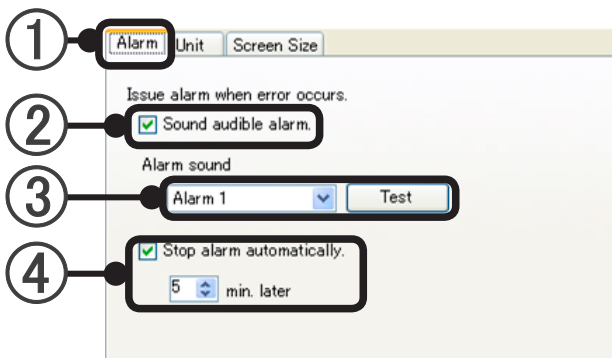

- ① Select the “Alarm” tab.
- ② Sound audible alarm checkbox: Selects whether or not an audible alarm is generated when an error occurs (When not checked, settings ③ and ④ cannot be made.)
- ③ Selects the type of alarm sound. The [Test] button generates the alarm sound for the test.
- ④ Stop alarm automatically checkbox: When checked, the time until the alarm sound is stopped automatically can be set by up/down buttons or key input. (1 to 60 minutes)

11-1-2 Temperature units setting

Sets the temperature display units.

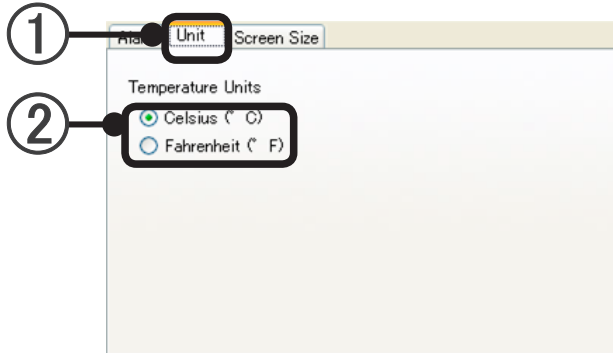

- ① Select the “Unit” tab.
- ② Temperature Units option button:
“Celsius” or “Fahrenheit” can be selected. Select the units to be used at temperature display.

11-1-3 Screen size setting

Selects the display size of the layout display section when moving between buildings and between floors at the monitor screen.

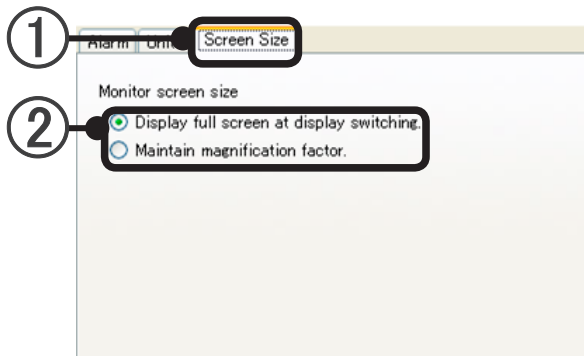

- ① Select “Screen Size” tab.
- ② Monitor screen size option button:
Select whether to return to full screen display or to use zoom rate during display when moving between buildings and between floors at the monitor screen.

VRF Controller Operation

- 12. Starting And Ending The VRF Controller
- 13. Task Tray Operation

12. Starting And Ending The VRF Controller

VRF Controller

The VRF Controller connects to the VRF System at the server PC and controls and monitors the system based on operation commands from the VRF Explorer. During VRF System operation, always keep the VRF Controller in the running state.

12-1 VRF Controller starting method

- 1 Start the VRF Controller from Windows® starting.
Select “Start” → “All Programs” → “System Controller for VRF System” → “VRF Controller”.

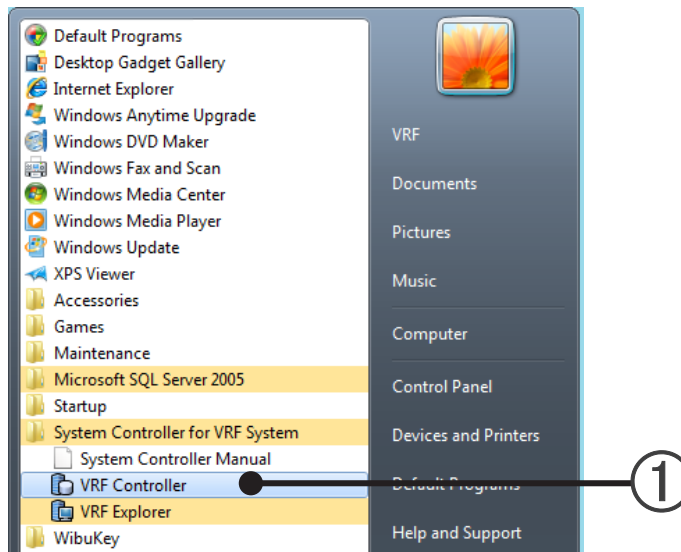

Note

When the message “Failed to recognize software protection key” appears, WIBU-KEY is not connected to server PC.
Connect WIBU-KEY to the USB port and restart the VRF Controller.

- 2 When the Login screen appears, enter the administrator’s password.

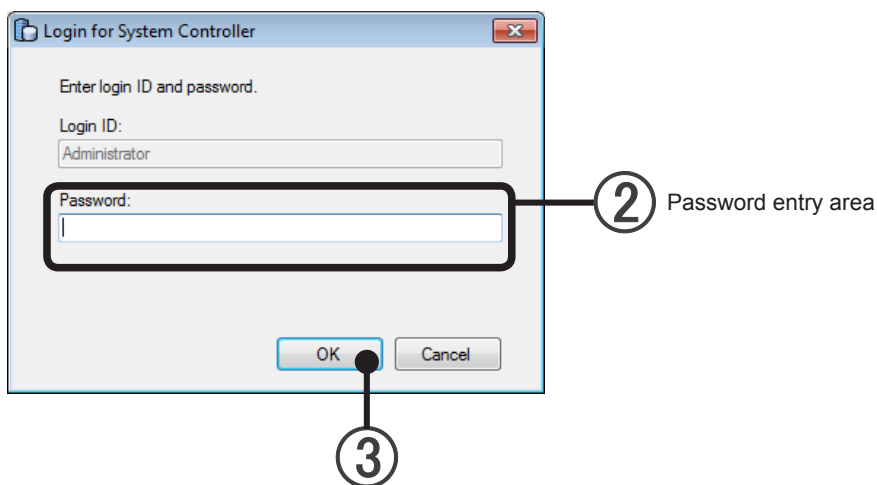

- 3 Click the [OK] button.

- ④ The VRF Controller starts.
While running, the VRF Controller resides on the Windows task tray.



- ⑤ The VRF Explorer starts automatically and the site group monitor screen appears.
→ See par. 16 Site Navigator

12-2 Ending the VRF Controller

Normally, the VRF Controller runs constantly. End the controller only when necessary for maintenance, or similar reasons.

- 1 End the VRF Controller.

Right click the VRF Controller icon on the task tray and select task tray menu → “End”.

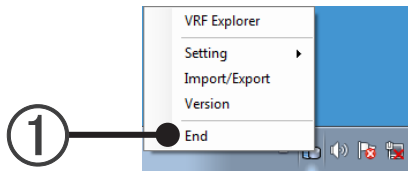

- 2 A Login screen appears. Enter the administrator's password.

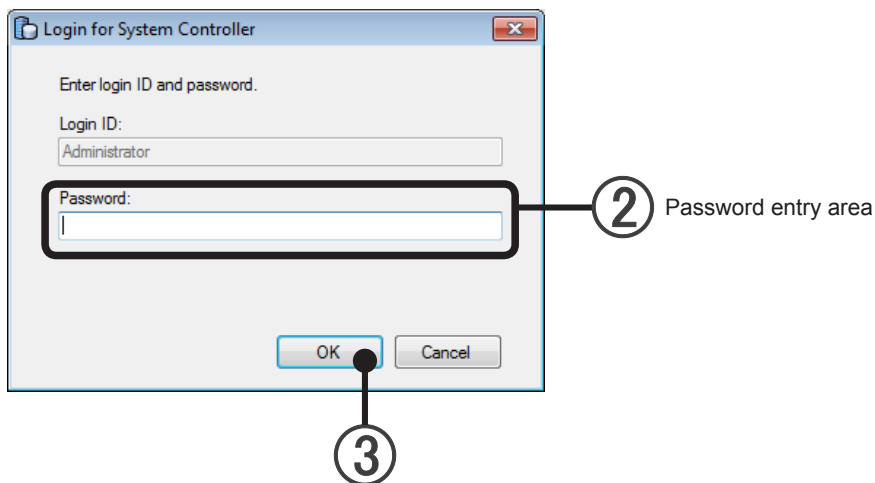

- 3 Click the [OK] button.
- 4 A confirmation screen appears. Click the [OK] button.

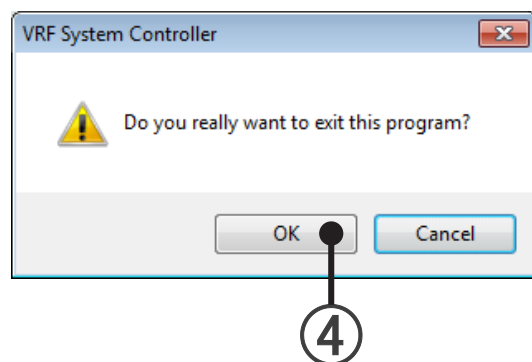

- 5 The VRF Controller ends.

Note

- When the VRF Controller ends, its functions as a System Controller stop. Therefore, air conditioner operation and management using the VRF Explorer can no longer be performed.
- While the VRF Controller is stopped, operation history, error history and other VRF System related data collection is not performed.
- When the VRF Controller is ended during Electricity Charge apportionment data collection period when the Electricity Charge apportionment function is used, correct Electricity Charge apportionment calculation may become impossible.

13. Task Tray Operation

While the VRF Controller is running, it resides on the Windows task tray and a small icon is displayed. All VRF Controller operations are performed using this icon.

- ① Right click the VRF Controller icon in the task tray menu.

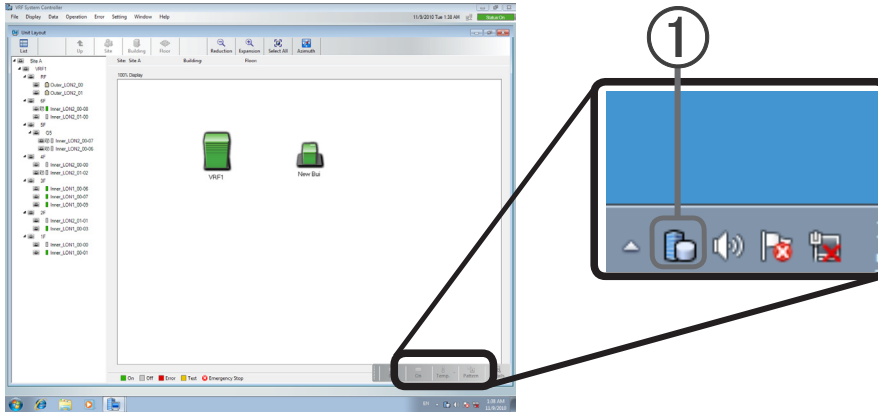

- ② A task tray menu appears. Select the operation you want to perform.

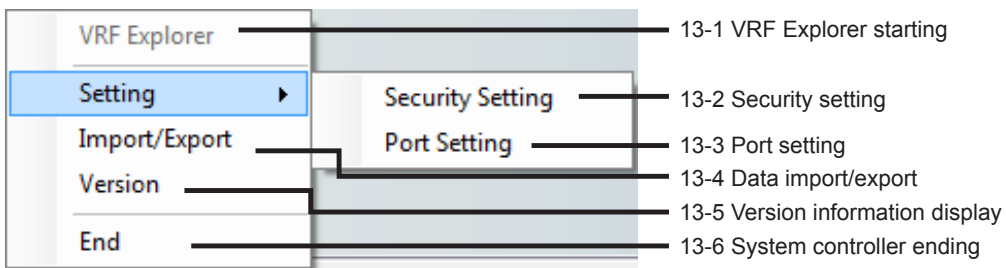

Note

- At Windows Default setting, the task tray is displayed at the bottom right-hand side of the screen.

13-1 VRF Explorer starting

Start the VRF Explorer.

- ① Select "VRF Explorer" from the task tray menu.
- ② The VRF Explorer starts and the Site Navigator appears.
→ See par. 16 Site Navigator

13-2 Security setting

Security setting sets the data encryption. Only the administrator can make this setting.

- ① Select "Security Setting" from the task tray menu.
- ② A Login screen appears. Enter the administrator's password.
- ③ A "Security Setting" screen appears. Click one of the items.

A: Encrypt transmitted data
B: Do not encrypt transmitted data

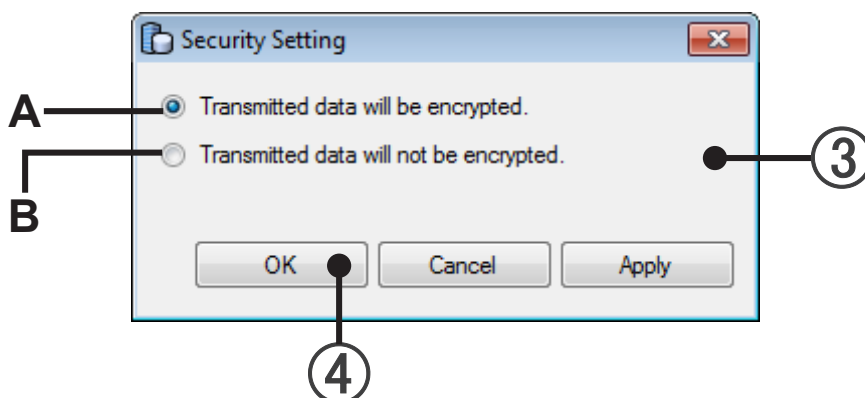

- ④ When the [OK] button is clicked, the set contents are reflected and security setting ends.

[Cancel] button

Ends security setting without saving the set contents.

[Apply] button

Saves the set contents.

(Security setting screen is displayed as it is.)

Note

- Normally select "Transmitted data will be encrypted". If there are exceptional circumstances, "Transmitted data will not be encrypted" can be selected.
- If the encryption settings are different, the VRF Controller and VRF Explorer cannot communicate. Match the VRF Explorer setting to the VRF Controller setting.
→ See par. 16-2 Site setting

13-3 Port Setting

Set the port of VRF Controller.

- ① Select "Port Setting" from the task tray menu.
- ② A Login screen appears. Enter the administrator's password.

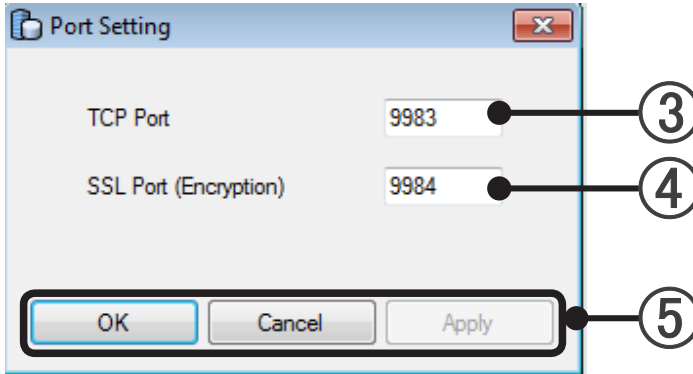

- ③ Enter TCP Port in 1024 to 65535 range. Initial value 9983
Specify the port No. which is not used by other applications.
When "Transmitted data will not be encrypted." is selected at 13-2 Security setting, this TCP Port can be used.
- ④ Enter SSL Port in 1024 to 65535 range. Initial value 9984
Specify the port No. which is not used by other applications.
When "Transmitted data will be encrypted." is selected at 13-2 Security setting, this SSL Port can be used.
- ⑤ When the [OK] button is clicked, the set contents are reflected and Port setting ends.
[Cancel] button
Ends Port Setting without saving the edited contents.
[Apply] button
Saves the set contents without ending setting.
(Port setting screen is displayed as it is.)

Note

Normally Port No. is not necessary to change.
Change the Port No. only when it is necessary to change due to network security.
When the Port No. is changed, set the VRF Explorer Port No. to the same number.
If the Port numbers of VRF Controller and VRF Explorer are different, they cannot be connected. Set the same Port No. in the "Site Setting" at "Navigator" screen. (See par. 16-2 Site Setting.)

13-4 Data import/export

Imports/exports registration data, layout data, and image data. Only the administrator can make this setting.

- Whether the data is all data or only the registration and layout data can be selected.
- The various collected data, etc. are backed up by exporting all the data.
- Server PC replacement and maintenance are performed easily and smoothly by using import/export of all data.
- The floor layout and unit layout can be easily redone any number of times by exporting the registration and layout data.

Registration data: Indoor unit and outdoor unit and other registration data acquired by system scan

Layout data: Unit layout data, floor layout data

Image data: Background image data at site display, floor background image data at floor display

- It may not be possible to Import/Export, depending on folder access rights. In such a case, use the “My Documents” folder.
- Please use import/export file with one language only. It may cause troubles just like display can not be acted on right etc.

13-4-1 All data

Import all the data.

- ① Select “Import/Export” from the task tray menu.
- ② A Login screen appears. Enter the administrator’s password.
- ③ An Import/Export screen appears. Select by clicking “All Data”.

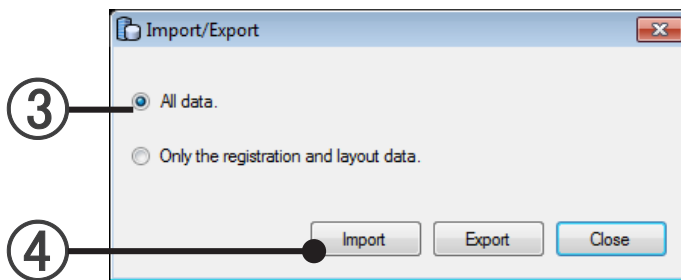

- ④ Click the [Import] button.
- ⑤ A file selection dialog box opens. Select the 6 files (extension: bak) to be imported. Multiple files can be selected by selecting each file while pressing the Ctrl key.

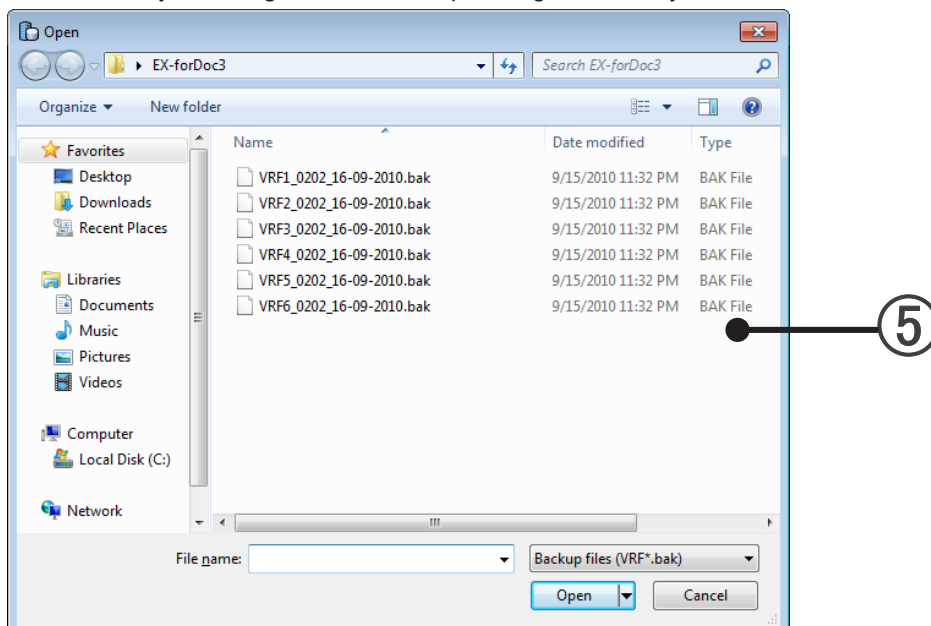

- ⑥ To import data, the VRF Controller must be stopped.
A confirmation screen appears. If okay, click the [OK] button.

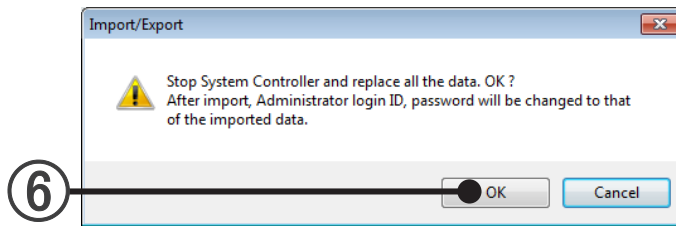

Note

The VRF Controller stops and the data are imported.

- ⑦ An import image or do not import image inquiry screen appears. To import an image, click the [Yes] button.

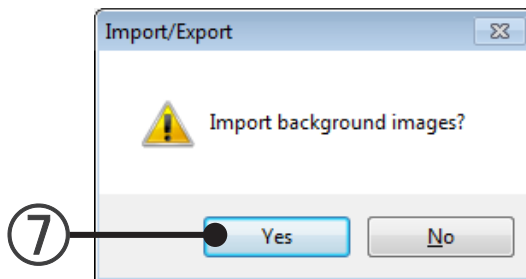

- ⑧ When the [Yes] button was clicked, a file selection dialog box opens. Select the image file.

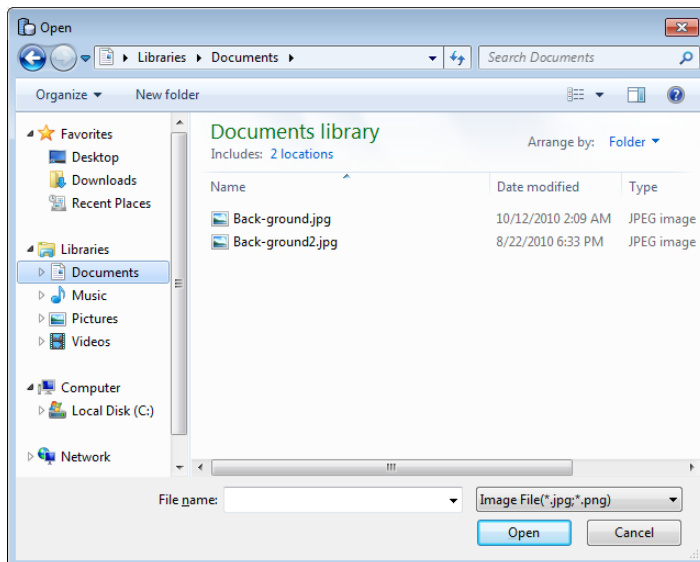

- ⑨ When import is complete, the message shown below appears. After clicking [OK] button, end the VRF Controller.

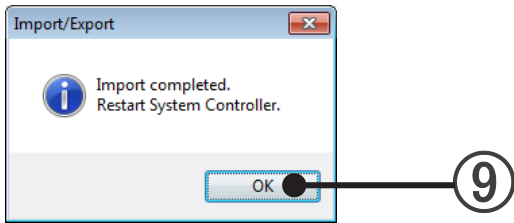

Note

To restart the VRF Controller, perform 12-1 VRF controller starting method after performing 12-2 Ending the VRF controller

The administrator's password will be changed to the imported data.

Export all the data.

- ① Select "Import/Export" from the task tray menu.
- ② A Login screen appears. Enter the administrator's password.
- ③ An Import/Export screen appears. Select by clicking "All Data".
- ④ Click the [Export] button.

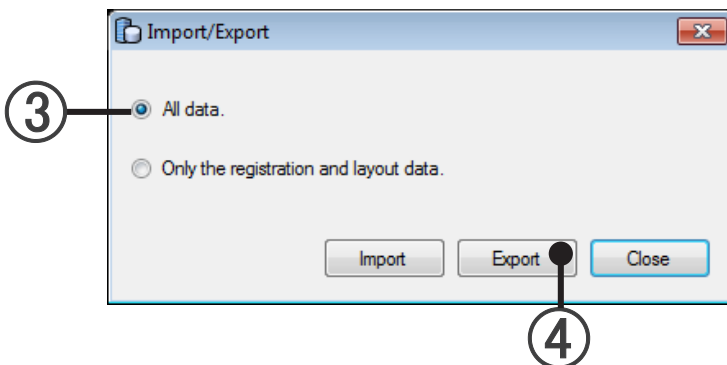

- ⑤ A folder selection dialog box opens. Select a folder or create a new folder and click the [OK] button. Data export begins.

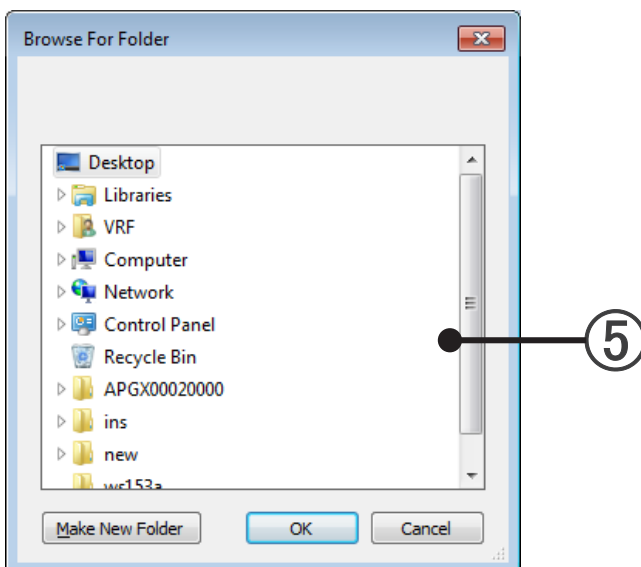

- ⑥ An export image or do not export image inquiry screen appears. To export an image, click the [Yes] button.

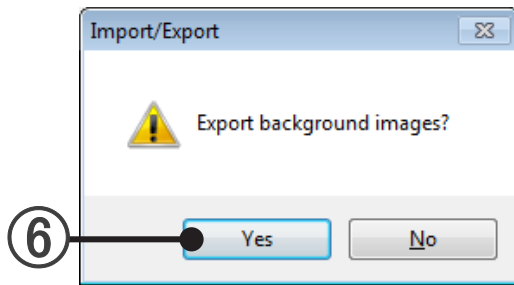

- ⑦ When export is complete, the message shown below appears. When the [OK] button is clicked, export work is completed.

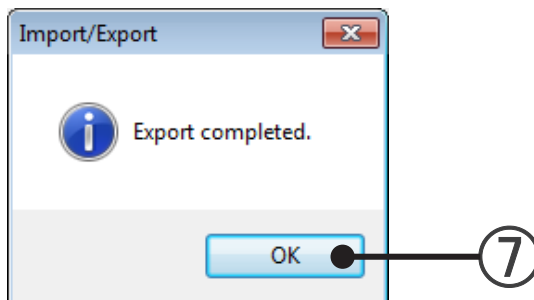

- ⑧ Close the Import/Export screen by clicking the [Close] button.

Note

When all data are exported, 6 data files (extension: bak) are created in the specified folder.
When an image file is exported, an image file is also created.
Do not change the exported file name.

13-4-2 Only the registration and layout data

Import the registration and layout data.

- ① Select "Import/Export" from the task tray menu.
- ② A Login screen appears. Enter the administrator's password.
- ③ An Import/Export screen appears. Select by clicking "Only the registration and layout data".

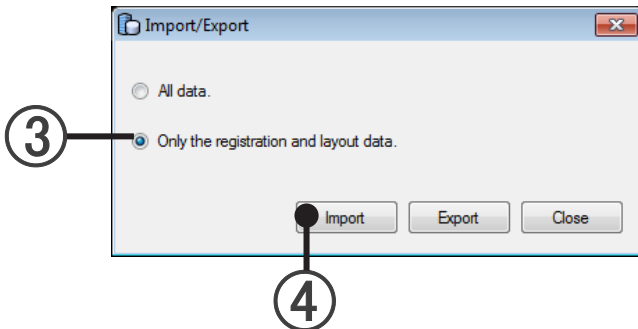

- ④ Click the [Import] button.
- ⑤ A folder selection dialog box opens. Select the folder containing the data files (extension: csv) to be imported.

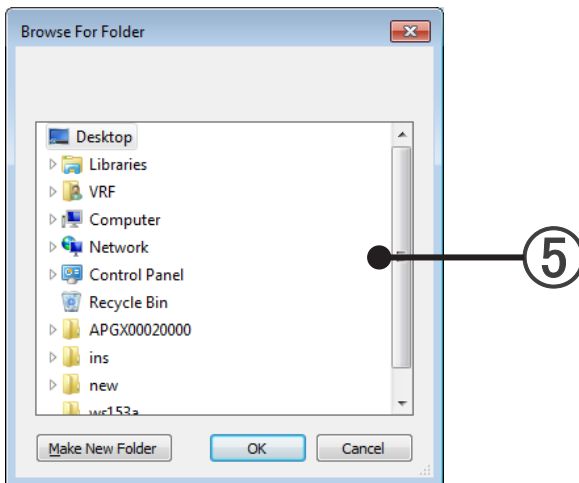

Note

If the data to be imported and the current unit registration are different, a confirmation message will be displayed.

- ⑥ To import data, the VRF Controller must be stopped. A confirmation screen appears. If okay, click the [OK] button.

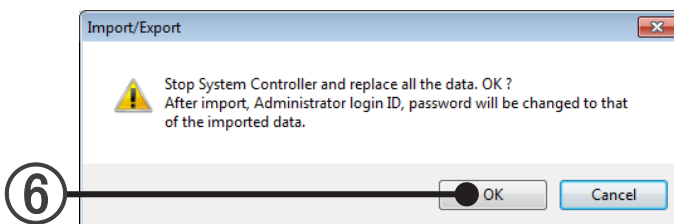

Note

The VRF Controller stops and the data are imported.

- ⑦ An import image or do not import image inquiry screen appears. To import an image, click the [Yes] button.

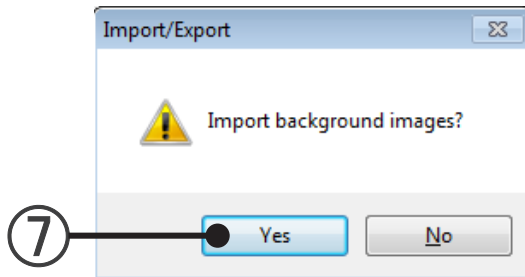

- ⑧ When the [Yes] button was clicked, a file selection dialog box opens. Select the image file.

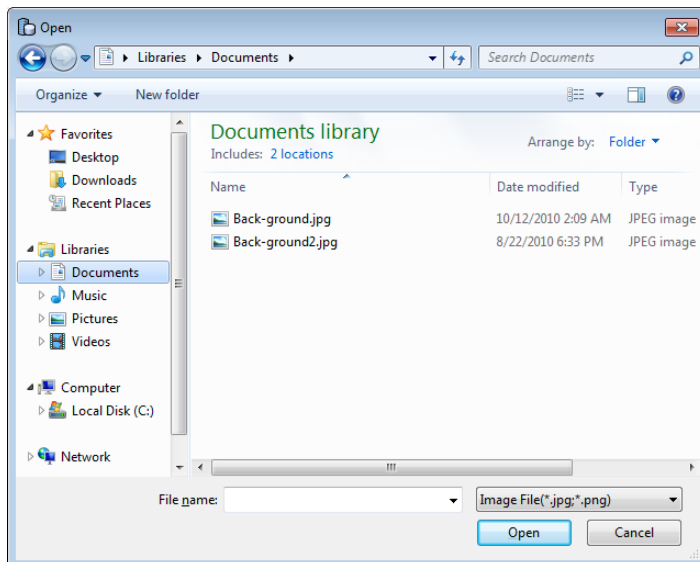

- ⑨ When import is complete, the message shown below appears. After clicking [OK] button, restart the VRF Controller.

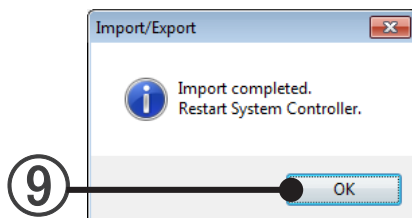

Note

To restart the VRF Controller, after performing “12-2 Ending the VRF Controller”, perform “12-1 VRF Controller starting method”.

You cannot import files created with the old version (0.1.0.0, 0.1.0.1) of the system controller.

Export the registration and layout data.

- ① Select "Import/Export" from the task tray menu.
- ② A Login screen appears. Enter the administrator's password.
- ③ An Import/Export screen appears. Select by clicking "Only the registration and layout data".

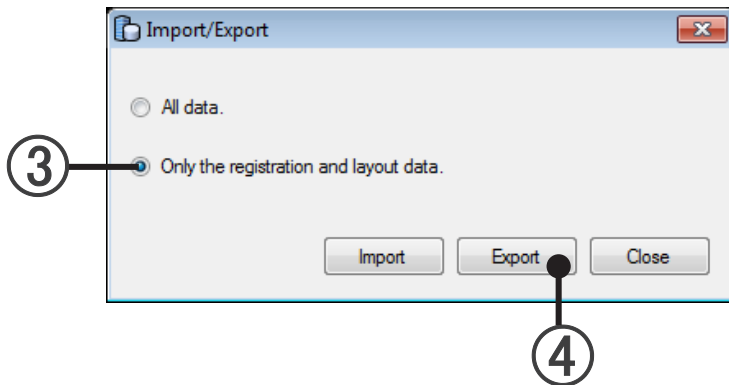

- ④ Click the [Export] button.
- ⑤ A folder selection dialog box opens. Select a folder or create a new folder and click the [OK] button. Data export begins.

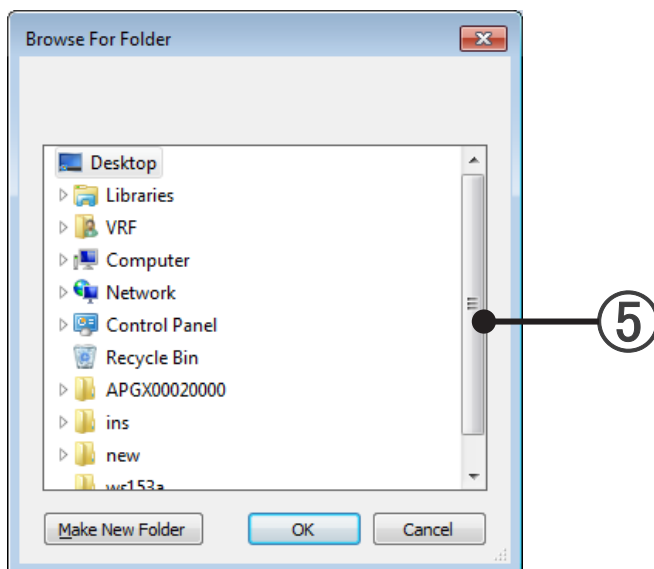

- ⑥ An export image or do not export image inquiry screen appears. To export an image, click the [Yes] button.

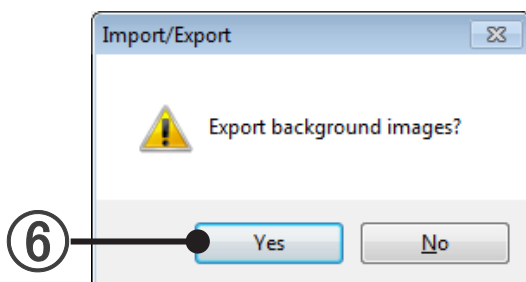

- ⑦ When export is complete, the message shown below appears.
When the [OK] button is clicked, export work is completed.

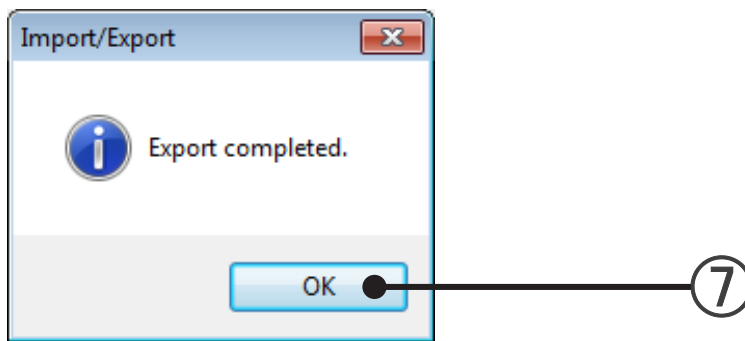

- ⑧ Close the Import/Export screen by clicking the [Close] button.

Note

When registration and layout data are exported, multiple data files (extension: csv) are created in the specified folder.
When an image file is exported, an image file is also created.
Do not change the exported file name.

13-5 Version

The version information can be viewed.

View the version information.

- ① Select "Version" from the task tray menu.
② The screen shown below appears.



- ③ To end the screen, click the screen.

13-6 End

Ends the VRF Controller. End the controller only when necessary for maintenance, or similar reasons.

End the VRF Controller.

- ① Select "End" from the task tray menu.

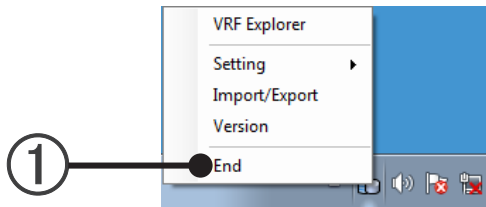

- ② A Login screen appears. Enter the administrator's password.
- ③ A confirmation screen appears. Click the [OK] button.

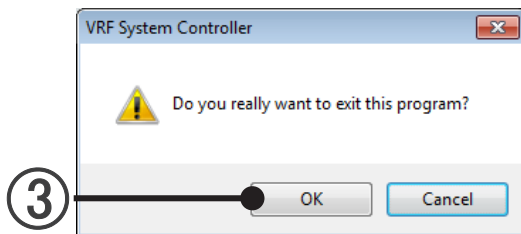

- ④ The VRF Controller ends.

Note

- When the VRF Controller ends, its functions as a System Controller stop. Therefore, air conditioner operation and management using the VRF Explorer can no longer be performed.
- While the VRF Controller is stopped, operation history, error history and other VRF system related data collection is not performed.
- When the VRF Controller is ended during Electricity Charge apportionment data collection period when the Electricity Charge apportionment function is used, correct Electricity Charge apportionment calculation may become impossible.

VRF Explorer Operation

14. Overview Of VRF Explorer
15. Starting And Ending The VRF Explorer
16. Site Navigator
17. Basic Operation
18. Operation Control
19. Schedule Operation
20. Error Monitoring
21. Operation Management
22. Electricity Charge Apportionment
23. Low Noise Operation

Standard Operation Case

Operation contents	Reference	Page
Starting	15-1 Starting the VRF Explorer	167
Ending	15-2 Ending the VRF Explorer	168
Monitoring multiple sites	16 Site Navigator	169
Monitoring multiple building on a site	17-3-1 Monitoring in the site display mode	189
Monitoring the unit of one entire building	17-3-2 Monitoring in the building 3D display mode	191
Monitoring the units for each floor in a building	17-3-3 Monitoring in the floor display mode	195
Simple operations (on, off, temperature setting)	18-1 Quick operation	209
Detailed operation setting	18-2 Detail operation	212
Limiting remote controller operation.	18-2-1 Basic operation	212
Setting upper/lower limits of temperature which can be controlled	18-2-2 Extended operation	217
Performing economy operation	18-2-2 Extended operation	217
Searching for units forgotten to be turned off and stopping operation	17-4 List display	198
Managing operation time using the scheduling function	19 Schedule operation	221
Error countermeasures	20 Error monitoring	241
Checking the unit that generated the error	20-4 Identifying the location of unit that generated the error	243
Checking the error contents (error code)	20-3 Error Notification screen	242
Stopping the alarm and scrolling	20-3 Error Notification screen	242
Checking if the same error occurred in the past	20-5 Unit error history	244
Checking whether or not the error occurs after countermeasures were taken	20-1 Overview of error notification 20-2 Status display	241
Viewing the operation history	21-1 Operation history	248
Performing electricity apportionment	22 Electricity Charge Apportionment	253
Calculating electricity charge	22-2 Apportionment Calculation execution	255
Creating the bill for electricity charge.	22-3 Bill creation	261
Set low noise operation for outdoor units	23. Low Noise Operation	265

14. Overview Of VRF Explorer

14-1 Composition of VRF Explorer

14-1-1 Screens making up VRF Explorer

VRF Explorer consists largely of 2 main screens. They are the Site Navigator and VRF Explorer main screens.

① Site Navigator

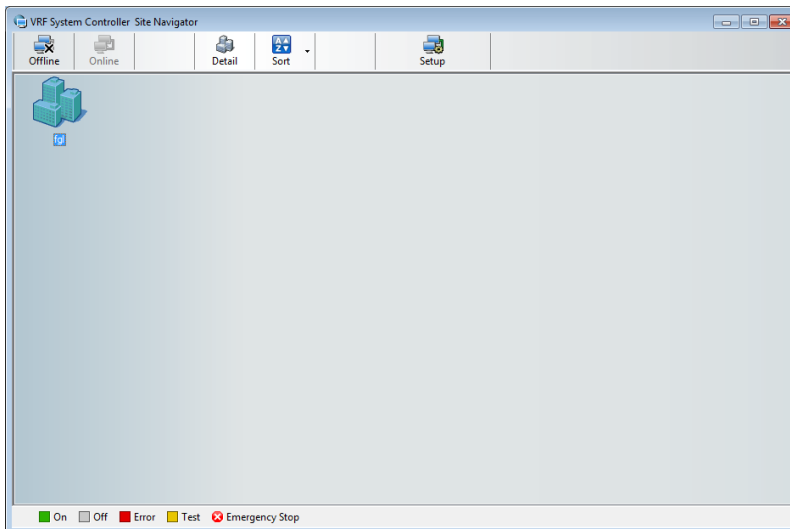

This screen monitors multiple sites in site units. The operation status and whether or not there are any errors can be checked in site units at this screen.

When multiple sites are centrally monitored, usually monitoring is performed only at this screen. When checking the detailed status and when controlling operation, the checks are made by opening the VRF Explorer main screen for each site.

When monitoring multiple sites by the Site Navigator, place all the monitoring sites into the online state.

→ See par. 16-1-1 Site Navigator

② VRF Explorer main screens

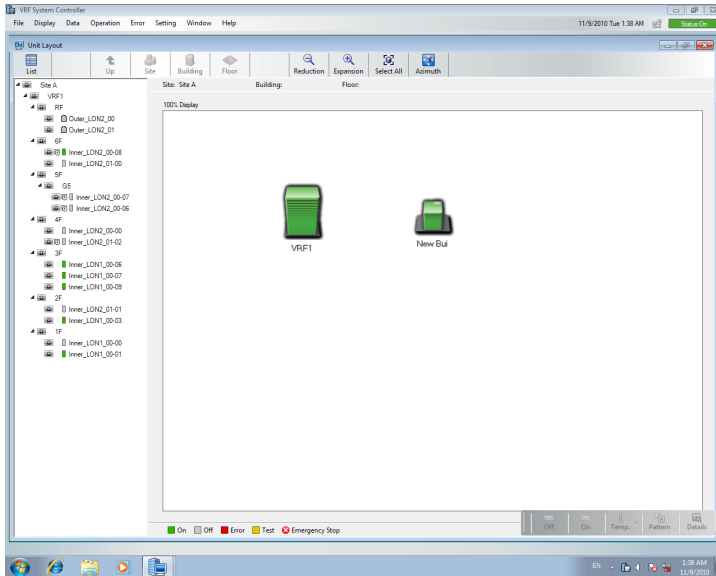

Detailed status monitoring, operation control, and other operations of each unit related to one selected site can be performed.

→ See par. 17-1-1 Composition of main screen

14-1-2 Screen transition

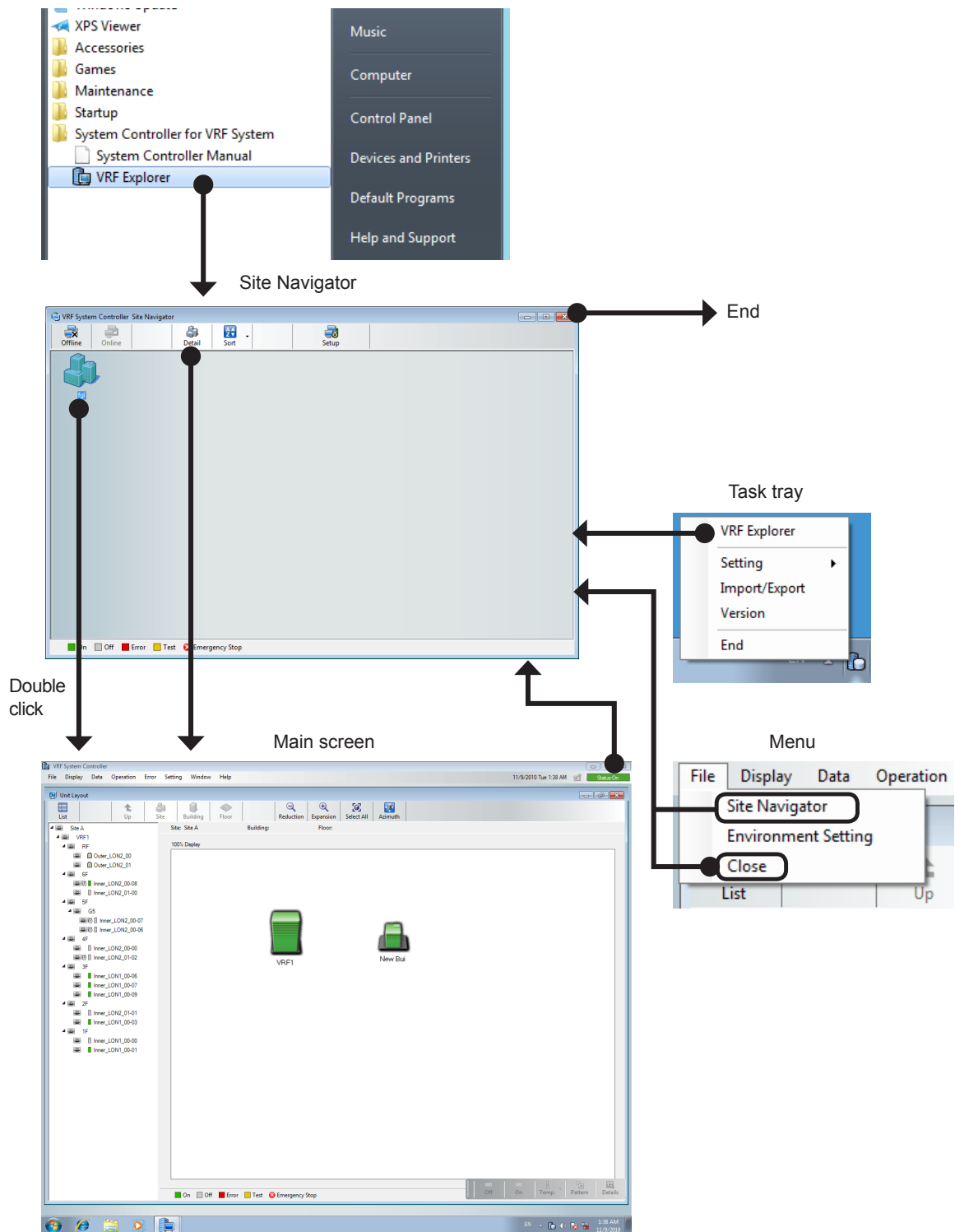

15. Starting And Ending The VRF Explorer

When the VRF Controller is started from the server PC, the VRF Explorer starts automatically.

15-1 Starting the VRF Explorer

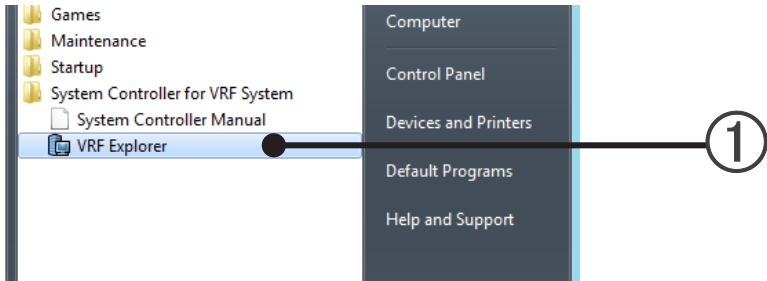

- ① Start the VRF Explorer from Windows® starting.
Select “Start” → “All Programs” → “System Controller for VRF System” → “VRF Explorer”
- ② Site Navigator appears.
→ See par. 16 Site Navigator

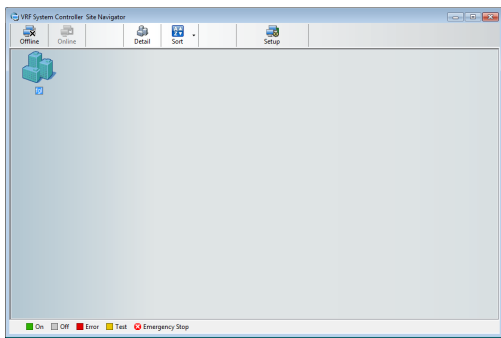

If the VRF Controller is already started (VRF Controller icon is displayed in the task tray menu), the VRF Explorer can be started from the task tray menu.

- ① Right click the VRF Controller icon in the task tray menu.

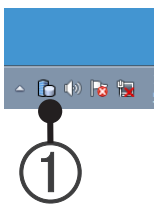

- ② Select "VRF Explorer".

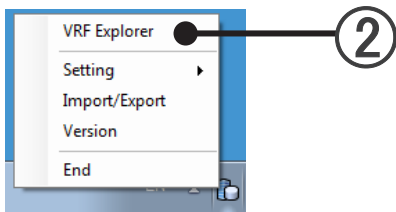

- ③ Site Navigator appears.
→ See par. 16 Site Navigator

15-2 Ending the VRF Explorer

- ① Select main screen menu → “File” → “Close”.

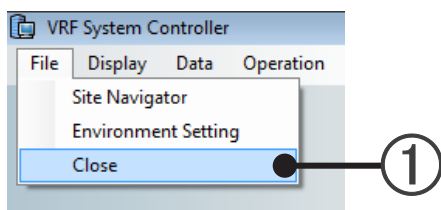

Main screen ends.

- ② Site Navigator appears. When Site Navigator is minimized, return it to its original size by selecting Site Navigator from the Task bar at the bottom of Windows. When there are the connecting sites, disconnect the communication. → See par. 16-1-3 Disconnection of communication to site

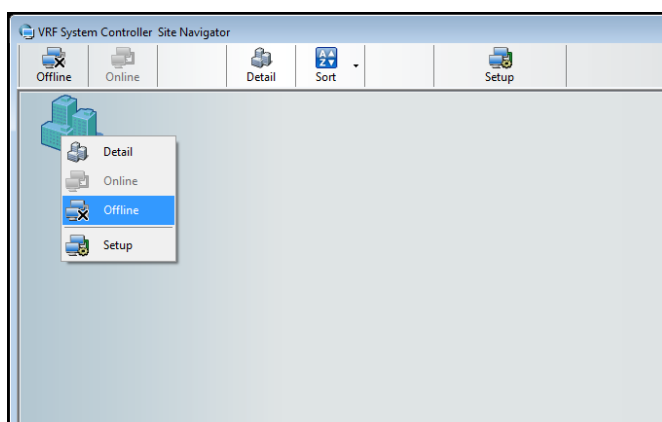

- ③ When not continuing monitoring of other sites, click the [×] button which closes Windows®.

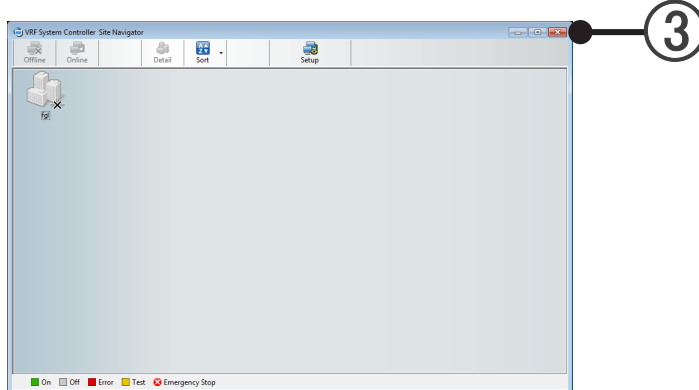

- ④ An end confirmation dialog box opens. Click the [OK] button.

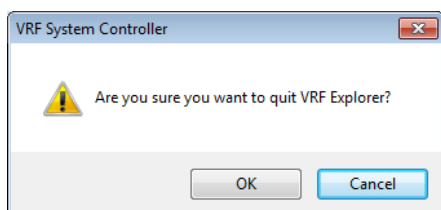

- ⑤ The VRF Explorer ends.

16. Site Navigator

The registered sites are displayed in a list and the site status can be checked.
 The Site Navigator can be used as follows.

When simultaneously monitoring multiple sites from a single client PC (max 10 sites)

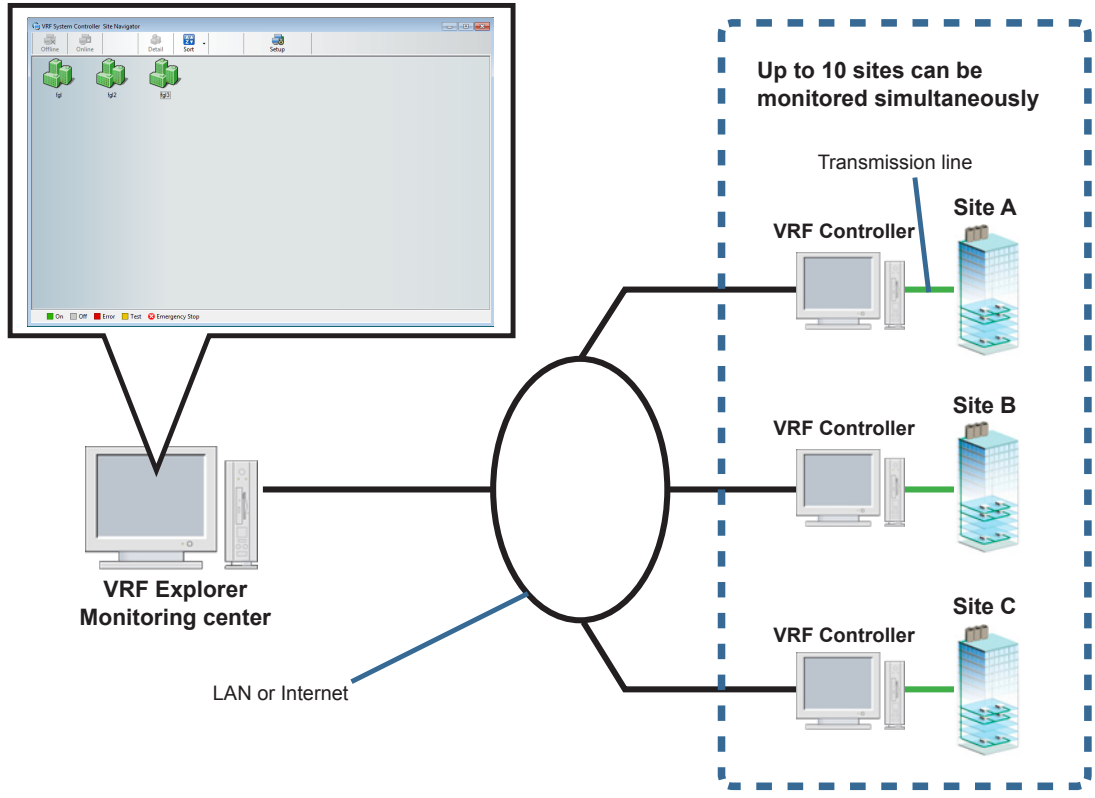

When monitoring sites managed by a server PC (1:1)

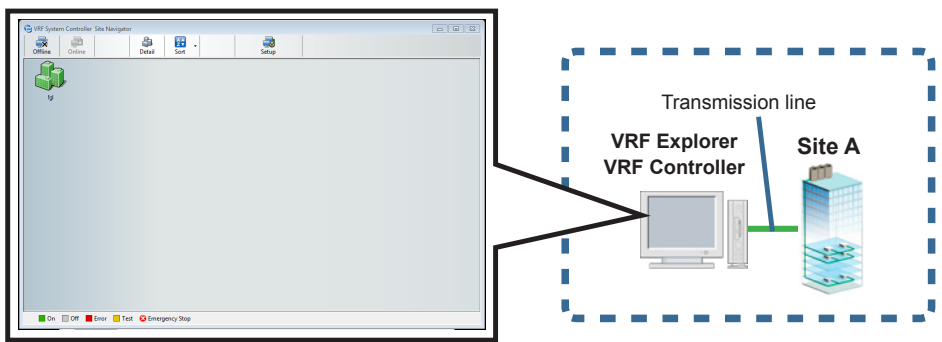

When using a public telephone line to monitor sites from a client PC (1:1)

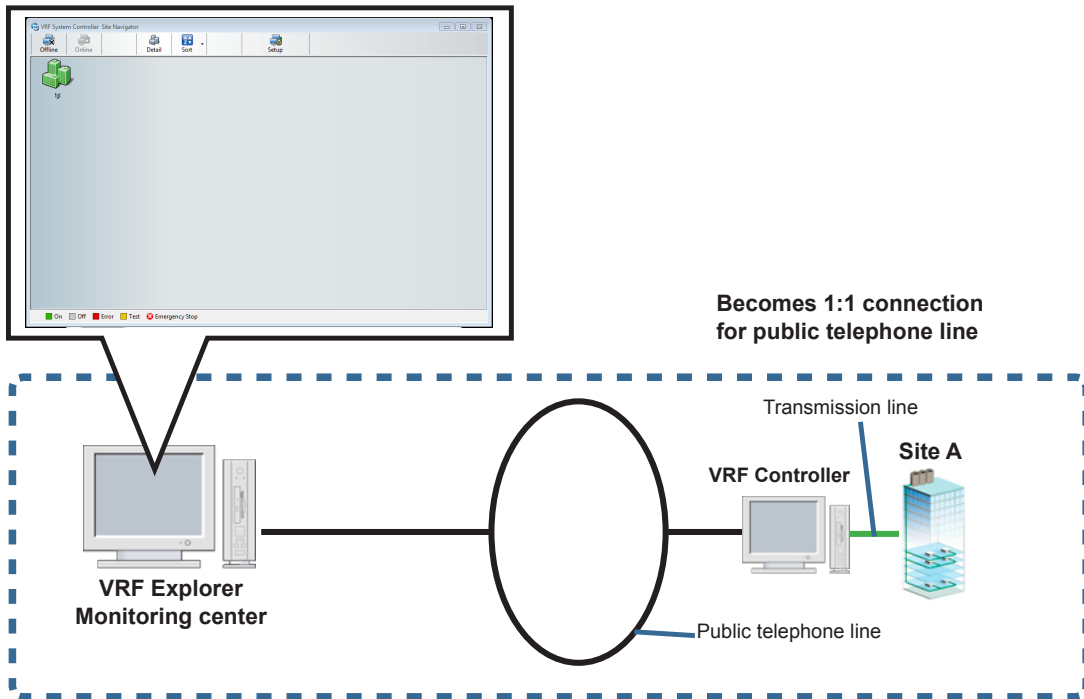

When simultaneously monitoring a single site from multiple client PCs (Max 5 client PCs)

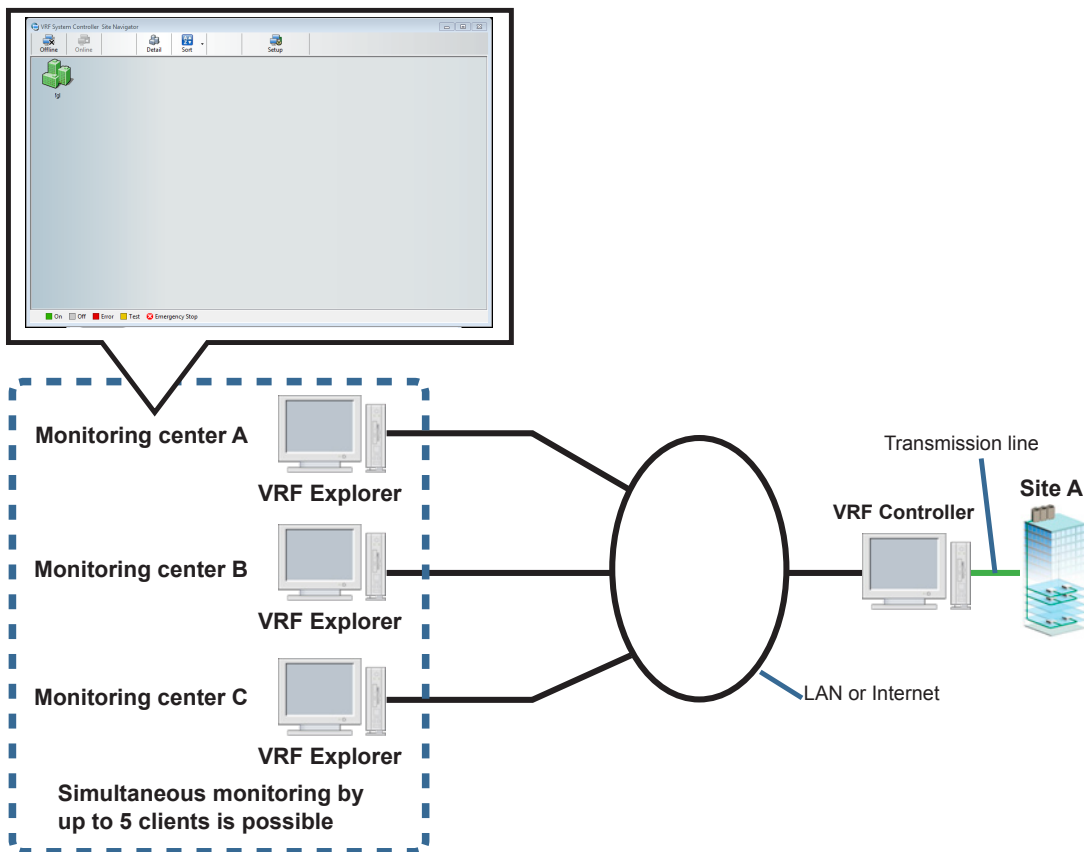

Note

When a network is not constantly connected between VRF Controller and VRF Explorer, connect and disconnect it manually at each use.

16-1 Site Navigator

Registered sites are displayed in a list and the status of each site can be checked. (Max 10 sites)
 When centrally monitoring multiple sites, usually do it at this screen. Place all the sites to be monitored into the online state.

16-1-1 Site Navigator

- ① Site Navigator screen. Registered sites are displayed by a list of icons.
 (The screen is an example of 3 registered sites.)
 - Up to 5 VRF Explorers can simultaneously connect to a VRF Controller.
 - Up to 10 sites can be registered at a VRF Explorer.
 - When a public telephone line is used, the connection between service PC and client PC is 1:1.

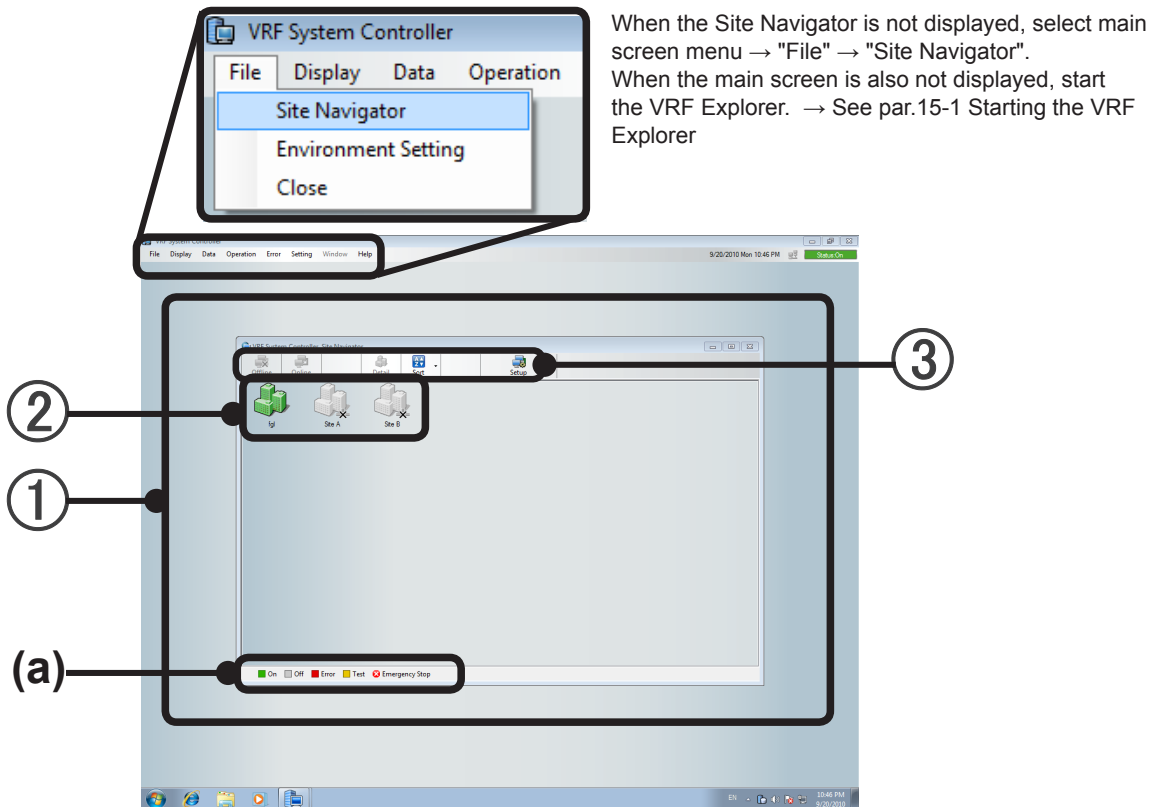

- ② Site icon. Represents the status of a site by color. See (a)Display color guidance for the contents.

	Offline Cannot communicate with site		Test Testing
	On Running		Error Error signal received
	Off Stopped		Emergency Stop Emergency stop signal received

* If even one of the units of a site is in one of the states shown above, its icon color is changed and it is displayed.
 The priority order is 1: Emergency Stop, 2: Error, 3: Test, 4: On, 5: Off.

Note

- If the site to be monitored is not registered, perform site setting. See par. 7-1-3 Object site setting

- ③ Tool icon. Connects and disconnects communication with a site and performs various settings. Details conform to the description of each operation.



* This picture is for description only. The items which can be selected are different depending on the operation.

Offline	Disconnects communication to a "site". (Selection is possible at Online sites)
Online	Connects communication to a "site". (Selection is possible at Offline sites) Monitors the site status.
Detail	Opens the main screen for displaying the detailed "site" data. Monitoring, operation control, etc. are performed at the main screen. (→ See par. 17-1 VRF Explorer screen composition.)
Sort	Switches the "site" icon of the state selected by pull-down menu to a higher rank. Online (connected site) On (running site) Off (stopped site) Error (error site)
Setup	Opens a "Site Setting" screen for setting the "site" connection. (→ See par. 16-2 Site setting)

Note

To monitor buildings and floors on a site, refer to par. 16-1-4 Site details display.

16-1-2 Communication connection to site

When "Offline", connect to a monitoring and control site.
(If even one site is not displayed, see par. 16-2 Site setting.)

- 1 Select the icon of the site to be connected.

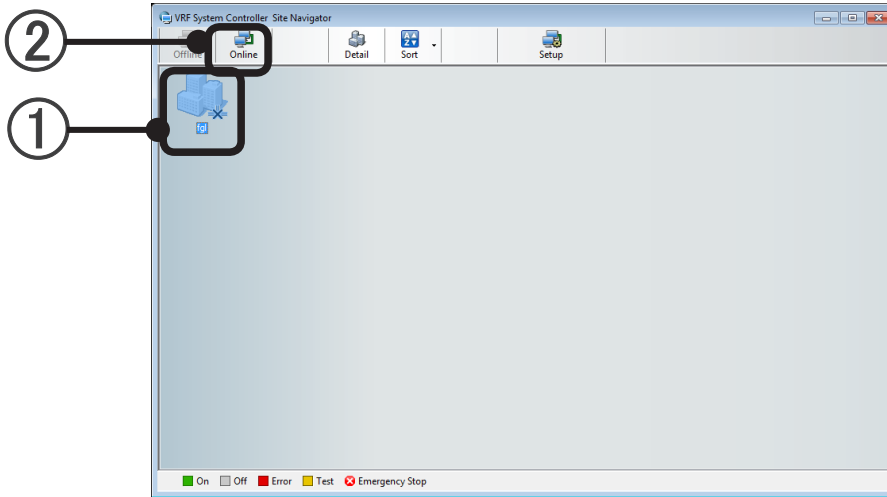

- 2 Click [Online] of the tool icons.
(This operation is also possible by right clicking a site icon and selecting "Online".)

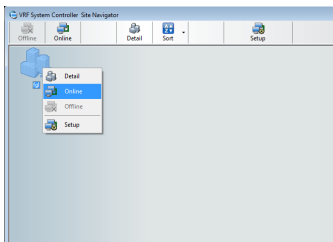

- 3 When a login screen is displayed, enter the Login ID and Password.
(Not displayed when set to auto login.)
See par. 8-1 User management settings for a description of Login ID and Password.
(For a client side, obtain the Login ID and Password from the server administrator.)

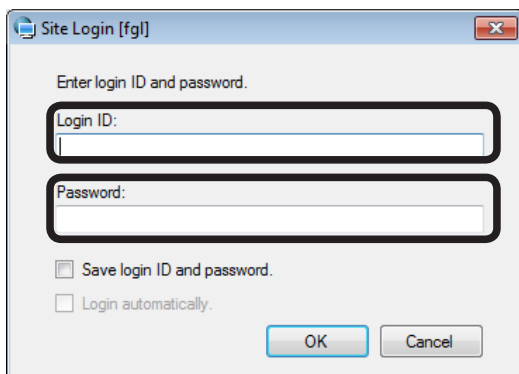

Note

Press OK, and if there is a difference between the server and client versions, a correction message will be displayed. Match the version to the server.

- ④ When a site is connected for the first time and when settings are changed, a site data acquisition dialog box is opened.
Click the [OK] button.

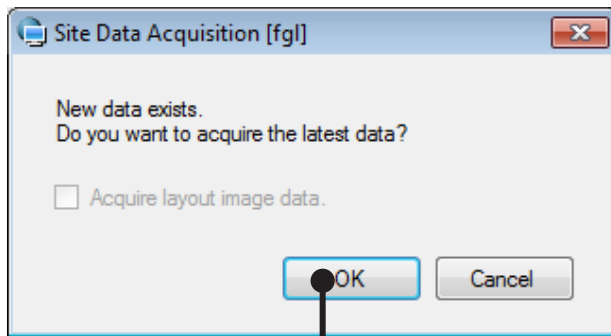

- ⑤ The site data is acquired.
- ⑥ After a while, the site icon changes to the connection state.
(The time up to connection depends on the type and state of the line.)

See par. 16-1-1 Site Navigator for the color of the connected site icon.

16-1-3 Disconnection of communication to site

Disconnects communication to a site. (Selection is possible at Online sites.)

This is effective when sites are not monitored continuously when a metering rate toll line is used.

- ① Select the icon of the site to be disconnected.
- ② Click [Offline] of the tool icons.
A confirmation message box opens. Click the [Yes] button.
(This operation is also possible by right clicking a site icon and selecting "Offline".)
- ③ After a while, the site icon changes to the disconnection state.
(The time up to disconnection depends on the type and state of the line.)

16-1-4 Site details display

Acquires the site data and monitors and controls the status of the buildings and units installed on the site.
(Depending on the access right setting, may be monitoring only.)

- ① Select the icon of the site whose data is to be acquired.

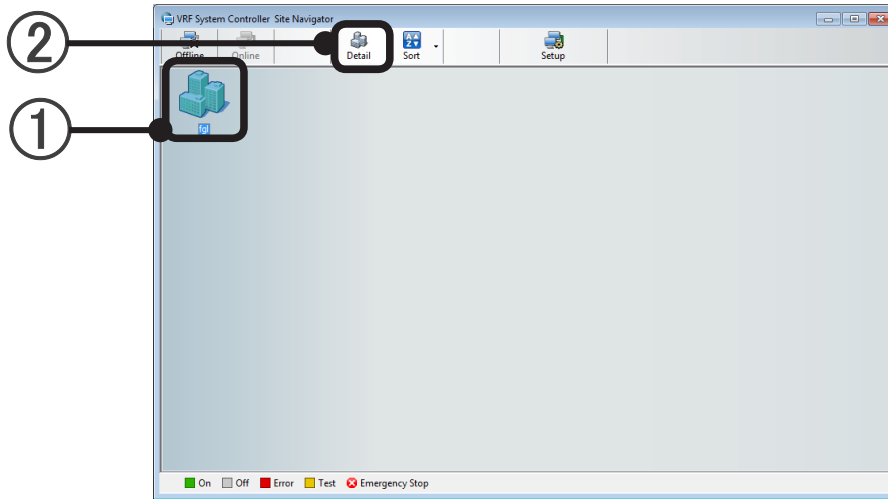

- ② Click [Detail] of the tool icons.
(This operation is also possible by right clicking a site icon and selecting [Detail]. In addition, this can be performed by double clicking the site icon.)

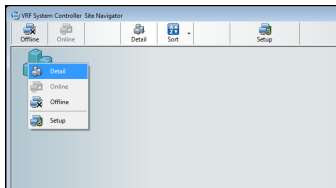

- ③ A monitor screen opens.
(See par. 17 Basic Operation.)

Note

- Connection processing is also performed automatically for sites in the Offline state.

16-2 Site setting

When adding and deleting sites to be monitored, perform monitoring site setting by Site Navigator. (Up to 10 sites can be registered.)

- 1 Click [Setup].

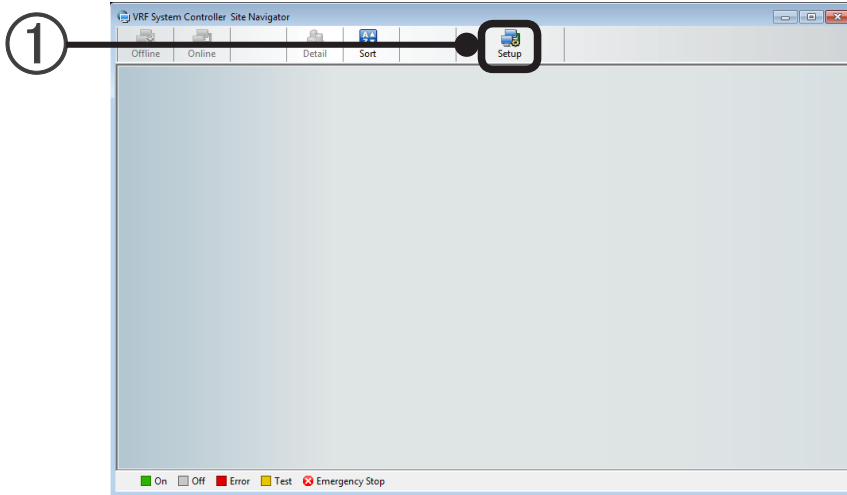

- 2 Enter the name of the site to be monitored at "Site Name".
(Within 20 characters of alphabet, numeric, and symbol)

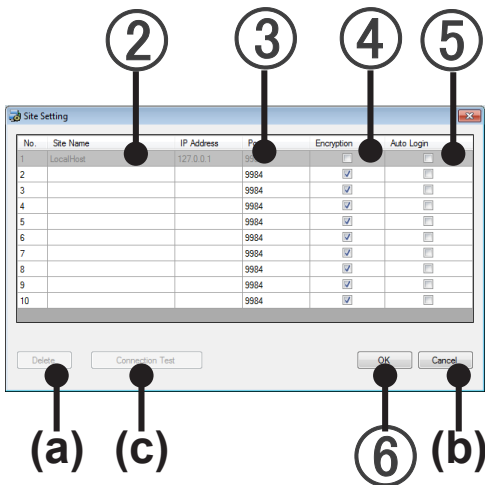

- 3 Enter the IP address. (For local connection, enter 127.0.0.1.)
 - For LAN connections and server PCs.
 - For internet connection, enter the global IP address of server PC.
 - For dial up connection, enter the IP address of server PC set by Incoming setting
→ See par. 6-1-1 Incoming setting
- 4 The Port No. to be set is displayed.
→ See par. 13-3 Port Setting
- 5 Specify encryption of the signals to be sent and received at the "Encryption" check box.
When the check box is checked, it is available.
Recommended when using the internet or other open line, etc.
Match with the setting of the connection destination VRF Controller.
→ See par. 13-2 Security setting

- ⑥ When the Auto Login check box is checked, the site is automatically connected by saved ID.
(Cannot be checked at new registration of a site. Can only be checked after initial login.)
- ⑦ Click [OK]. Then the site is registered.

(a) [Delete] button

Deletes the connection to selected site settings.

(b) [Cancel] button

Ends the site setting without saving the set contents.

(c) [Connection Test] button

Performs the connection test to the VRF Controller (Server Software).

(In this connection test, encryption check is not performed. For encryption, match the server settings.)

Note

You can set a name for Site Name different than that set on the VRF Controller side. Set the name while bearing in mind the method of management.

If encryption is not the same, communications between connected server PC and client PC is impossible.

17. Basic Operation

17-1 VRF Explorer screen composition

17-1-1 Composition of main screen

① Main screen: This is the basic screen of the VRF Explorer.

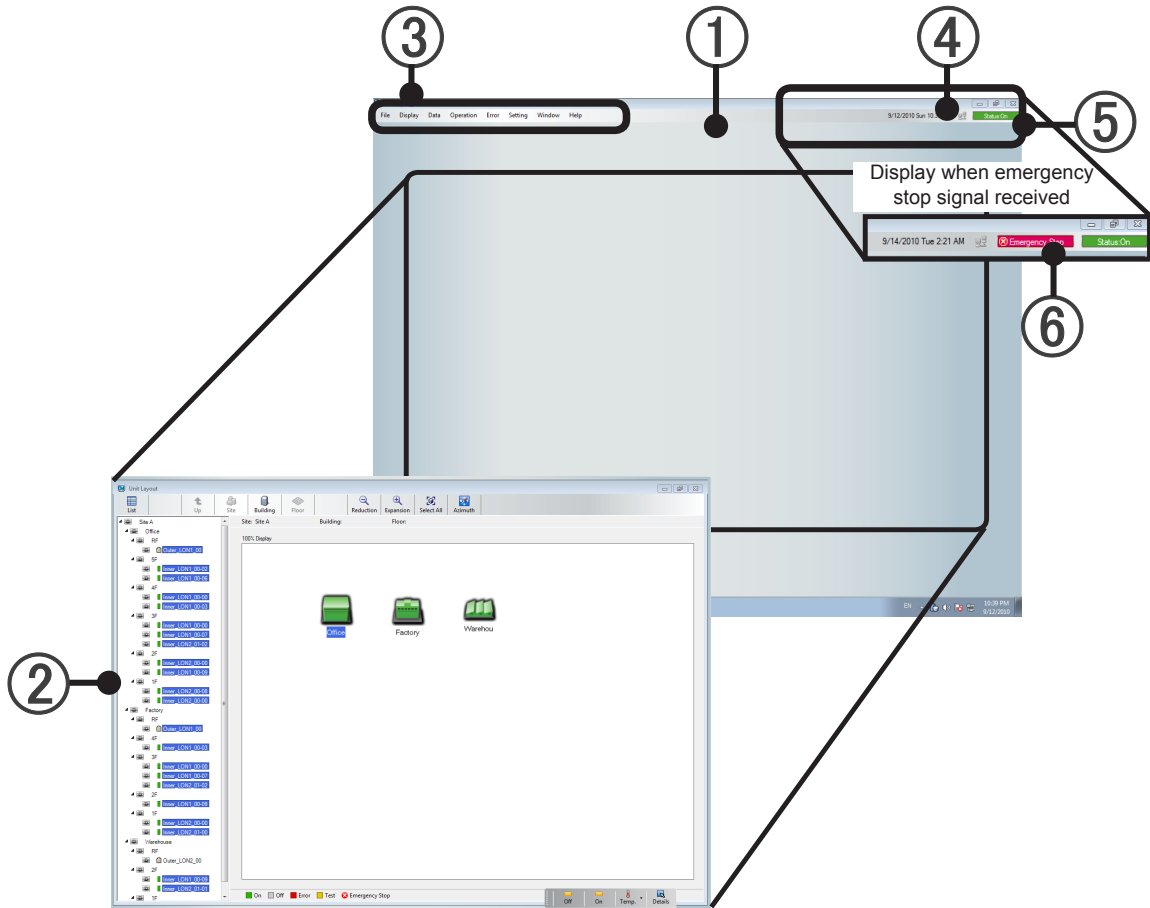

② Function screens: Monitor and operate the site buildings and floors and units. The screen is switched with the menu of ③ (See ③ Menu.)

③ Menu: Calls the function screens which perform various settings, monitoring, and control. For details, see the description of each operation

“File”

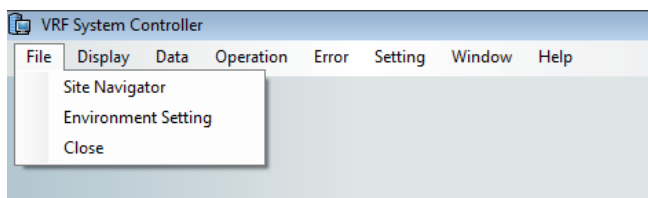

“Site Navigator” (16-1.) P.171

Displays the site group monitor screen.

“Environment Setting” (11-1.) P.144

Sets the alarm volume, temperature units, and site and floor display scale.

“Close”

Closes the main screen. Communication with the VRF Controller and site monitoring are continued.

“Display”

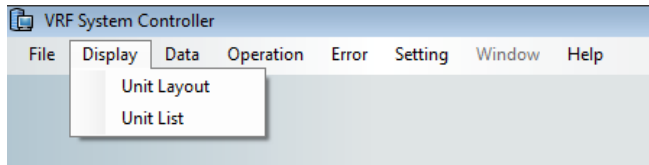

the monitor screen display.

“Unit Layout” (17-3) P.189

Displays the buildings on a site.

“Unit List” (17-4) P.198

Displays a unit list.

“Data”

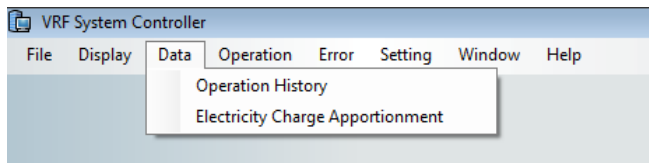

“Operation History” (21-1) P.248

Displays, outputs, and deletes the operation history from the unit and the system controller control history.

“Electricity Charge Apportionment” (9.) P.115, (22.) P.253

Performs electricity charge apportionment setting and apportionment calculation.

* Can be selected only by users with the Electricity Charge Apportionment right.

“Operation”

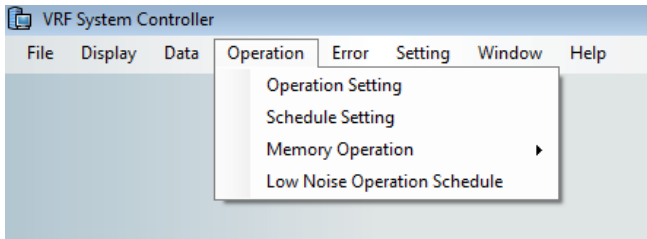

“Operation Setting” (18-2) P.212

Controls the operation of R/C group and group.

* Can only be selected by users with the Operation Control right.

“Schedule Setting” (19.) P.221

Set the operation schedule of R/C group and group.

* Can only be selected by users with the Operation Control right.

“Memory Operation” (18-3) P.219

Performs the following settings:

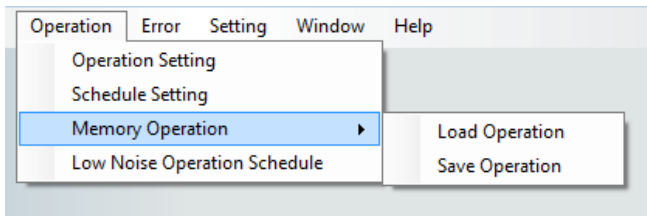

“Load Operation” (18-3-1) P.219

Reads the preset operation pattern to R/C group and group.

* Can only be selected by users with the Operation Control right.

“Save Operation” (18-3-2) P.220

Saves the set operation pattern to R/C group and group.

* Can only be selected by users with the Operation Control right.

“Low Noise Operation” (23.) P.265

Sets the schedule of low noise operation mode for groups.

* Can only be selected by users with the Operation Control right.

“Error”

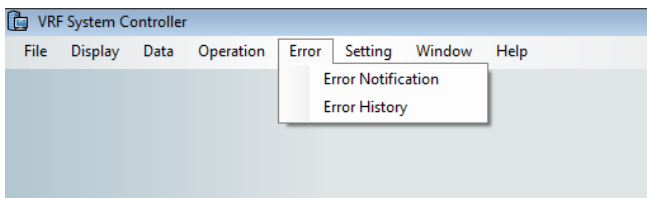

“Error Notification” (20-1) P.241

Opens an error notification screen.

“Error History” (20-5-2) P.245

Displays, outputs and deletes current errors and past errors history.

“Setting”

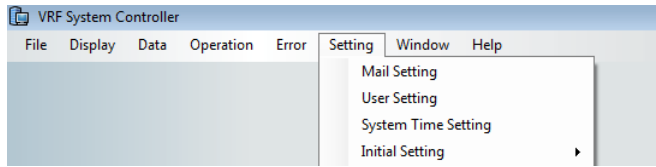

“Mail Setting” (10.) P.141

Performs setting which automatically sends an error notification email when an error occurs.

- * Can only be selected by users with the Setting right.

“User Setting” (8-1) P.80

Displays a list of the users registered at the VRF Controller.

New user registration and modification and deletion of the registered contents of selected users can be performed.

- * Can only be selected by users with the User Setting right.

“System Time Setting” (8-2) P.84

Sets the time of the controller connected to VRF network.

- * Can only be selected by users with the Setting right.

“Initial Setting” (8-3) P.86

Performs the following settings:

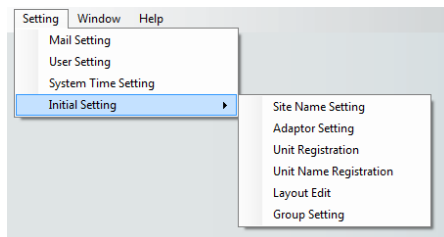

“Site Name Setting” (8-3-1) P.87

Sets and changes the site name.

- * Can only be selected for local connection of users with the Setting right.

“Adaptor Setting” (8-3-2) P.88

Changes adaptor name and checks connection status.

- * Can only be selected for local connection of users with the Setting right.

“Unit Registration” (8-3-3) P.89

Acquires by network scan the registration information, capacity, and other information of the connected units.

- * Can only be selected for local connection of users with the Setting right.

“Unit Name Registration” (8-3-4) P.92

Sets and changes R/C group and outdoor unit group name.

- * Can only be selected for local connection of users with the Setting right.

“Layout Edit” (8-3-5) P.95

Edits the site, building, and floor layouts.

* Can only be selected by users with the Setting right.

“Group Setting” (8-3-6) P.109

Performs arbitrary group setting and change by outdoor unit, R/C group, and outdoor unit group. (Max 3 hierarchy)

Batch control and information can be acquired by setting a group.

Group setting by different refrigerant systems and duplicate setting by multiple groups are also possible.

* Can only be selected by users with the Setting right.

“Window”

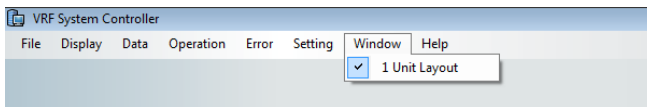

Displays a monitor screen and working screen list and moves to the selected screen. (Depending on the operation, the contents pulled down are different.)

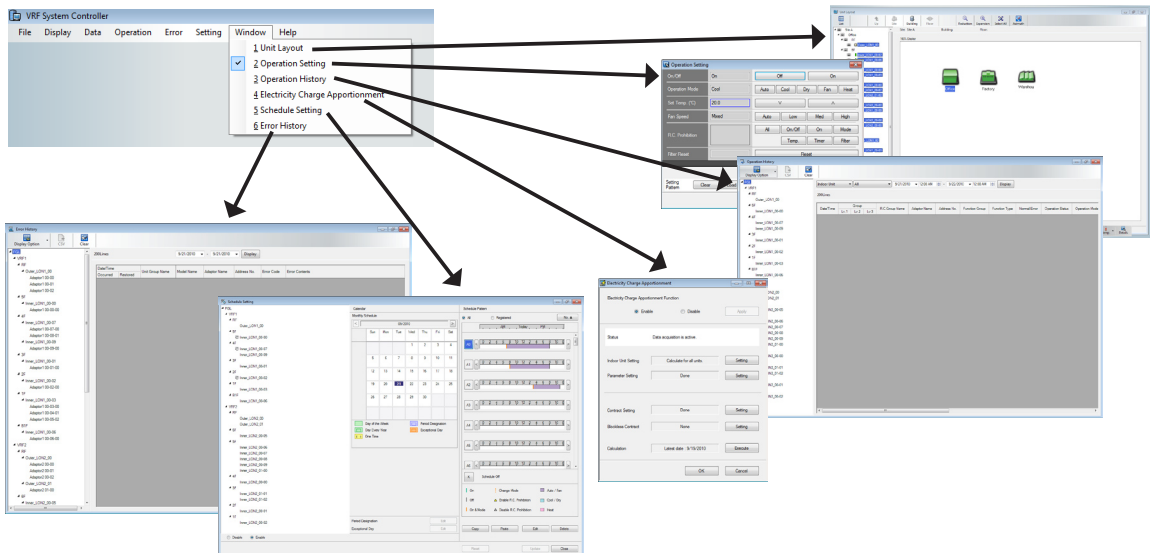

However, cannot be selected during "Mail Setting", "User Setting", or "Initial setting". (Other operations are not performed until setting is complete.)

“Help”

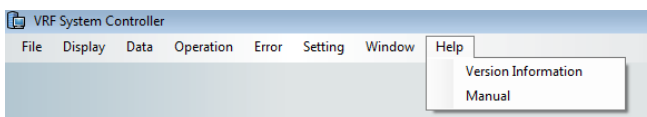

“Version Information”

Displays the start screen and verifies the version. When the screen is clicked, the window closes.

“Manual”

Displays a PDF file of this manual.

- ④ User icon: When this icon is pointed with the mouse, the user name currently connected from a remote site is displayed.
* For local connection only, the icon is displayed.

- ⑤ Status icon: When all the recognized units are stopped, [Status: Off] is displayed.

Status: Off

If even one recognized unit is running, [Status: On] is displayed.

Status: On

When an error is generated, [Status: Error] blinks. When this icon is double clicked while it is blinking, the error notification screen is re-displayed. For details, see par. 20. Error monitoring.

Status:Error ↔ Status:Error
Blink

- ⑥ Emergency Stop: If even one of the units received an emergency stop signal, the [Emergency Stop] icon is displayed.

Emergency Stop

17-1-2 Function screens

Function screen: Various function screens are opened in the main screen by selecting the main screen menu. The display contents are different depending on the function.

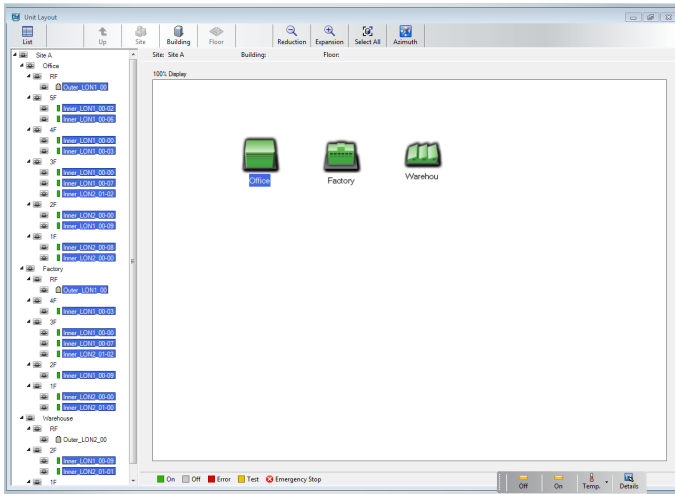

Function screen example (monitor screen)

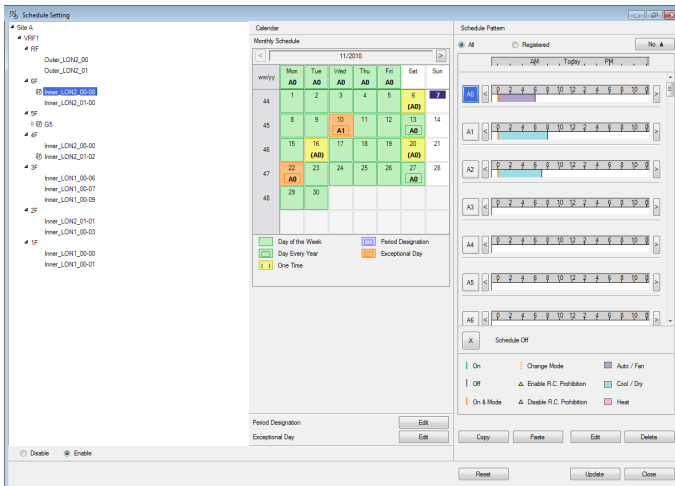

Example of function screen (Schedule setting screen)

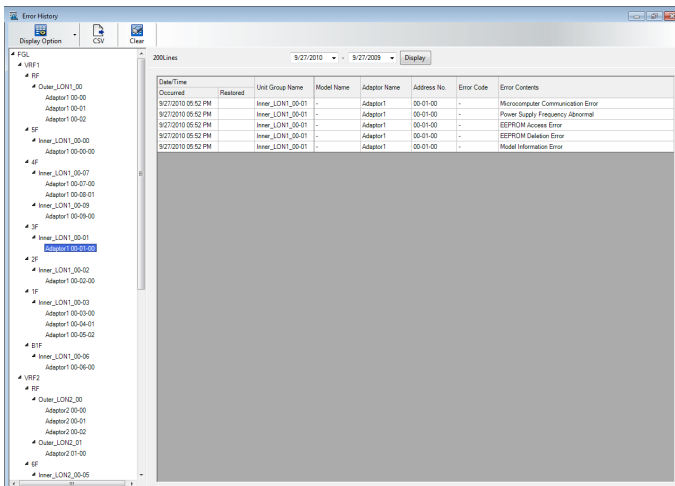

Example of function screen (Error history screen)

17-2 Overview of monitor screens

Multiple buildings on a site are monitored from a client PC

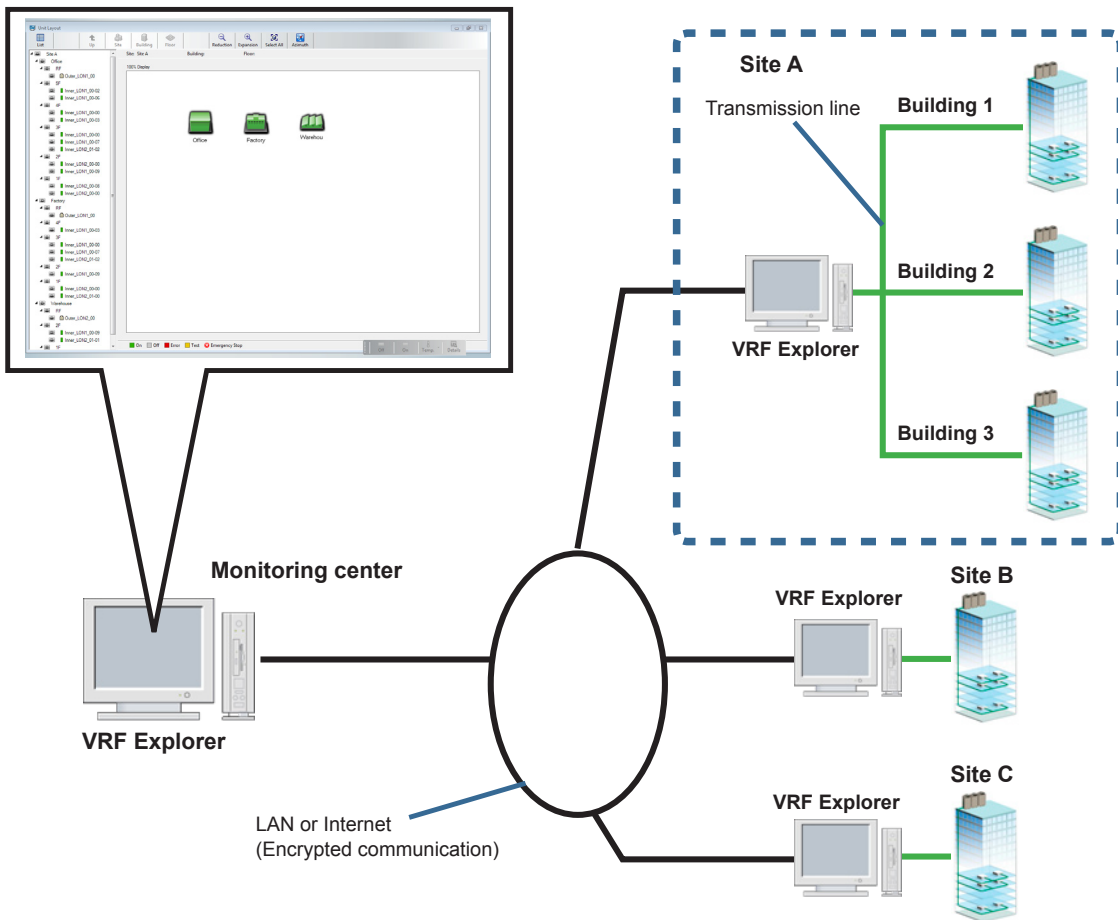

Multiple buildings on a site are monitored from a server PC

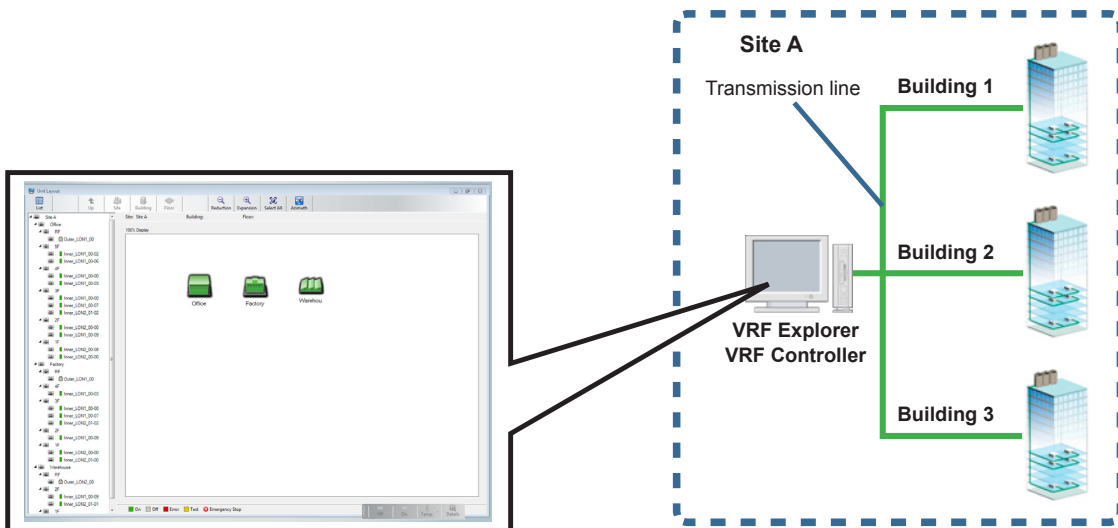

17-2-1 Monitor screens

The status of the units on a site is monitored for building and floor units. The display contents are different depending on the operation. (May be monitoring only depending on the user access right setting.)
To display this screen, click the main screen menu → “Display” → “Unit Layout”.

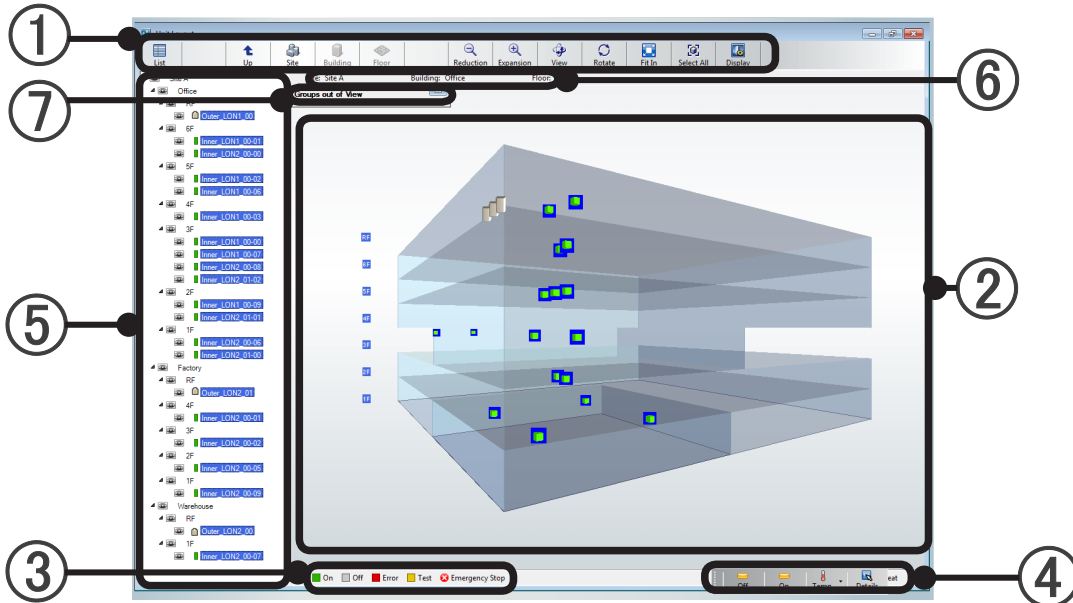

① **Tool icons:** Perform display contents switching, etc.

The items which can be selected are different depending on the display and operation contents.

List	Switched to list display.	
Up	Each time the [Up] button is Clicked, [Floor display] → [Building 3D display] → [Site display] and viewpoint are switched to wide range.	
Site	Switches to site display.	
Building	Switches to building 3D display.	
Floor	Switches to floor display.	
Reduction	Reduces and displays the ② layout view.	
Expansion	Expands and displays the ② layout view.	
View	The mouse drag function at building 3D display switches from movement of the entire screen to rotation of the building. When enabled, the button enters the pressed state.	
Fit In	Display the whole building/floor.	
Display Option	Unit setting display items can be selected Select the necessary items from the pull-down menu.	
	Fixed Display	Also displayed when not pointing with the mouse
	Schedule	Displays timer setting yes/no by icon.
	Filter	Displays filter sign by icon.
	Management	Displays the identification of master indoor unit and slave indoor unit by icon. (Cooling/Heating switching cannot be performed for slave indoor unit.)
	R.C. Prohibition	Displays the R/C prohibited state.
Temperature Limit	Displays the set temperature upper/lower limit restriction state.	
Rotate	Switches building 3D display rotation on/off. (*Building 3D mode only)	
Select All	Selects all the units displayed by ② Layout view (list view).	

Display	The building 3D display color and rotation speed can be changed. (*Building 3D display mode only) [Display Adjustment] screen opens. → P.175
Azimuth	Displays the azimuth. When displayed, the button enters the pressed state.

② **Layout view** (list view): Displays the status of the units on the site in building and floor units or in a list.

(a) Site Monitor Mode

Displays the unit operation status in building units.

For details, see par. 17-3-1.

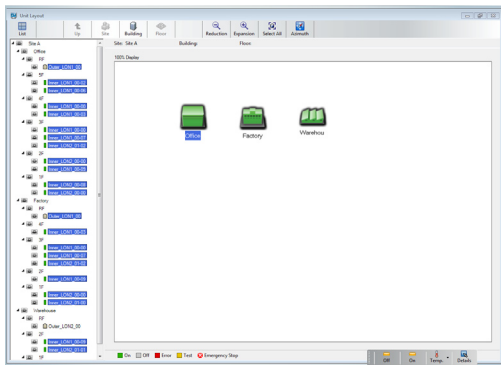

(b) 3D Building Mode

Displays the operation status of all the units in the building in transparent 3D.

For details, see par. 17-3-2.

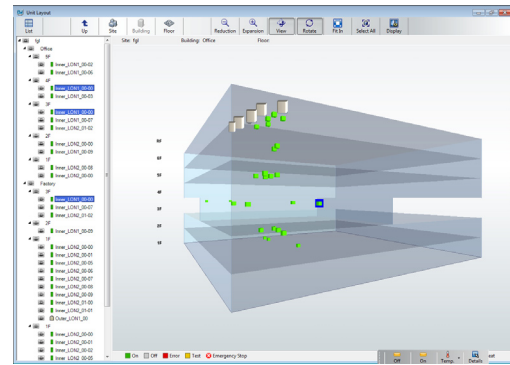

(c) Floor Layout Mode

Displays the operation status of the units on a floor by ground plan.

For details, see par. 17-3-3.

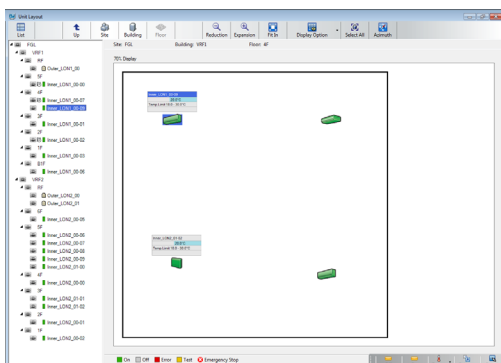

(d) List Mode

Displays the detailed operation status of R/C group in the specified range in a list.

For details, see par. 17-4.

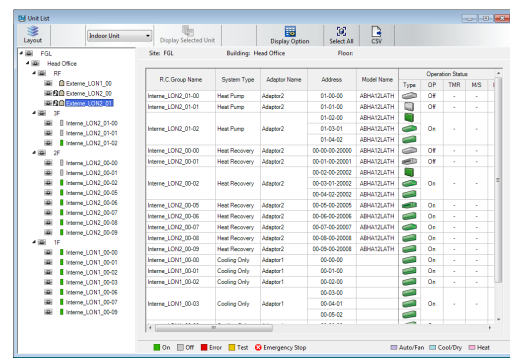

③ **Display color guidance**: Describes the icon colors and background colors for the status of the units on the site.

④ **Control pad**: Performs simple operation of selected site, group, and R/C group. For details, see par. 18-1 Quick Operation.

⑤ **Tree display**: Site, building, floor, and other groups can be displayed and selected by hierarchy. For details, see par. 17-5 Tree display.

⑥ **Display name**

The site name, building name, and floor name displayed by ② Layout view (list view) can be displayed. (Cannot be displayed when building name and floor name span multiple names.)

- ⑦ Groups out of View: When there are units currently selected outside the units displayed by ② Layout view (list view), those units are displayed.

When the unit is clicked, the ② Layout view (list view) is switched to display of the clicked unit. When the minimize button is pressed, only the title is displayed.

When the maximize button is pressed, the entire screen is displayed.

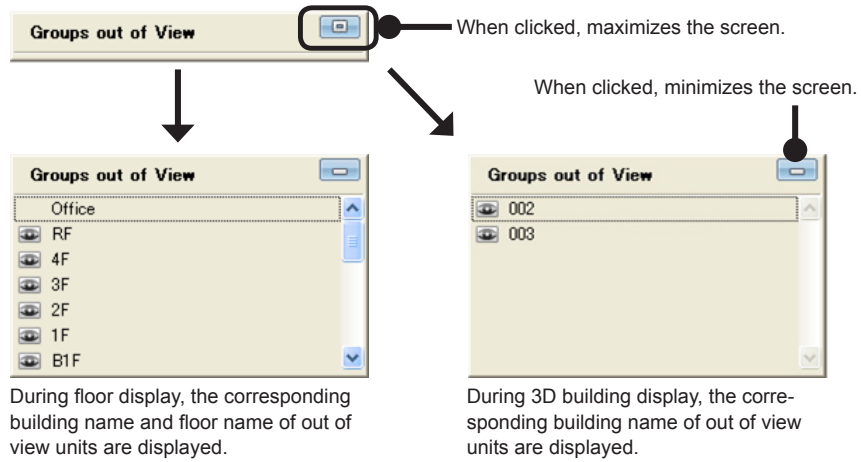

17-3 Layout display

17-3-1 Monitoring in the site display mode

Units on a site are monitored in building units. (Max 20 buildings)
 To display this screen, click [Site] of the tool icons on the monitor screen.

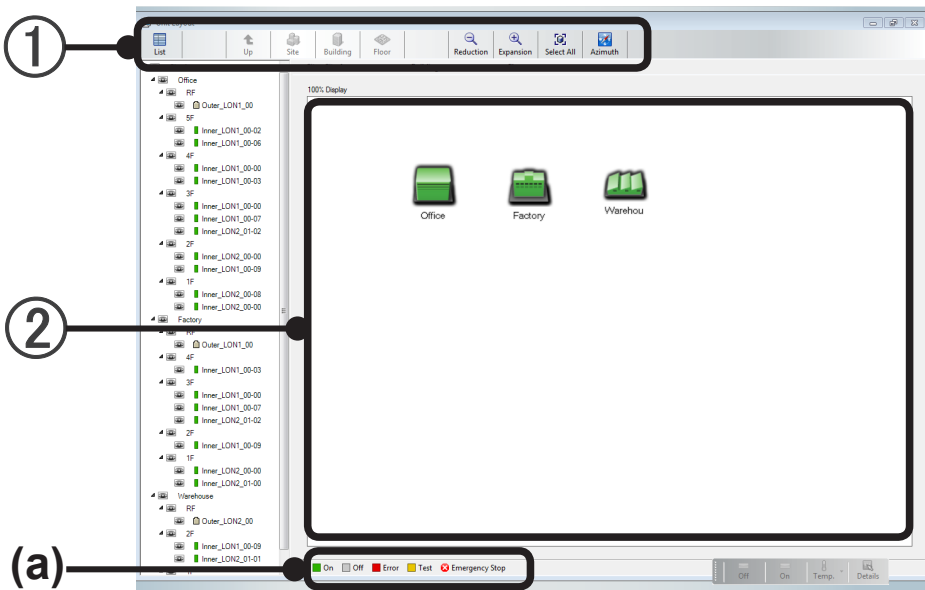

① **Tool icons:** Perform display contents switching, etc.







List	Switched to list display.
Building	Switches to building 3D display.
Reduction	Reduces and displays the ② layout view.
Expansion	Expands and displays the ② layout view.
Select All	Selects all the units displayed by ② Layout view (list view).
Azimuth	Displays the azimuth. When displayed, the button enters the pressed state.

② Layout view: Displays a list of the buildings on the site selected by 16-1-4 Site details display.

The status of the units in the building is displayed by building icon color.
For the meaning of the colors, see (a) Display color guidance.

Example of icon display (Example of building icons)

	On: Running		Test: Testing
	Off: Stopped		Emergency Stop: Emergency stop signal received.
	Error: Error signal received.		

* If even one unit in the building is in one of the states above, the icon color changes and is displayed.
The priority order is 1: Emergency Stop, 2: Error, 3: Test, 4: On, 5: Off.



In the state in which R/C group of the entire building was selected, the background of the building name changes to blue.



In the state in which the R/C group of part of the building was selected, the background of the building name changes to light blue.

Building 3D display

When the building icon is double clicked, display of that building is switched to 3D display.

Map move

The entire screen can be moved by dragging the mouse using the left button.

Zoom

Zoom in and zoom out are possible by turning the mouse wheel.
(This operation can also be performed using the + and - keys on the keyboard.)

Note

When the building icon is hidden in the layout view, display it by dragging in the view or by adjustment of layout setting.

In addition, background image display and additional setting of more complex building shapes, etc. are also possible by Layout editing. For details, see par. 8-3-5 Layout editing.

17-3-2 Monitoring in the building 3D display mode

Switch the selected building to 3D display. All the units in the building are monitored.
To display this screen, click [Building] of the tool icons on the monitor screen.

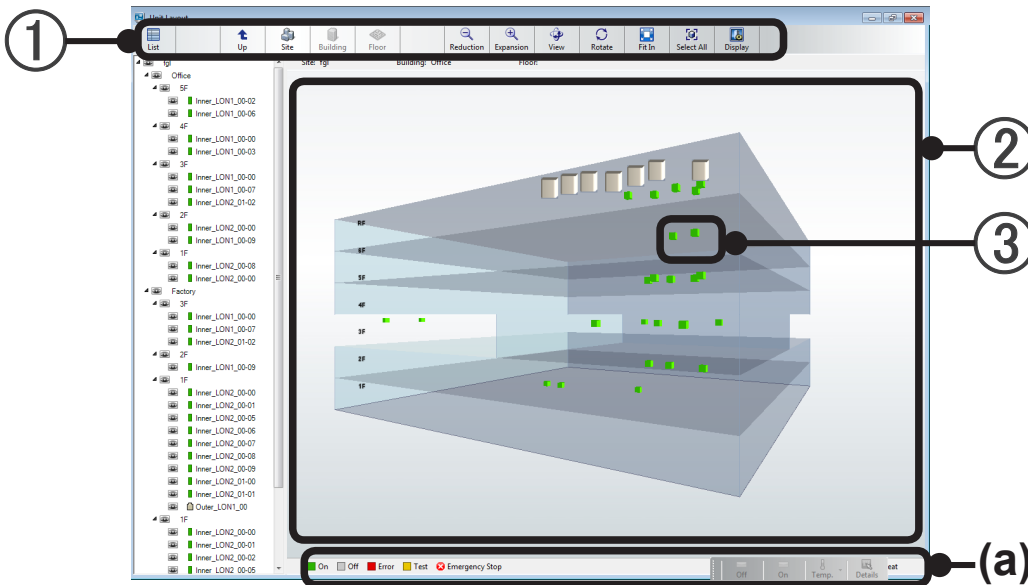

① **Tool icons:** Perform display contents switching, etc.



List	Switched to list display.
Up	[Building 3D display] → [Site display] Viewpoint are switched to wide range.
Site	Switches to site display.
Floor	Switches to floor display.
Reduction	Reduces and displays the ② layout view.
Expansion	Expands and displays the ② layout view.
View	The mouse drag function at building 3D display switches from movement of the entire screen to rotation of the building. When enabled, the button enters the pressed state.
Rotate	Switches building 3D display rotation on/off. (*Building 3D mode only)
Fit In	Display entire building
Select All	Selects all the units displayed by ② Layout view (list view).
Display	The building 3D display color and rotation speed can be changed. (*Building 3D display mode only) [Display Adjustment] screen opens. P.175

- ② **Layout view:** The state of all the units in a building can be checked in 3 dimensions.

Screen move

The entire screen can be moved by dragging the mouse using the left button.
(This operation can also be performed using the direction keys on the keyboard.)

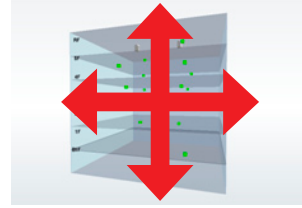

Viewpoint move

The building can be rotated up, down, left, and right by dragging the mouse using the right button.
(This operation can also be performed using the Shift + direction keys on the keyboard.)

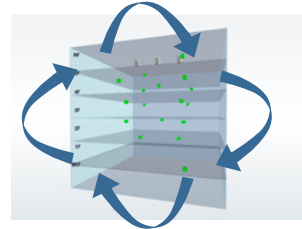

Zoom

Zoom in and zoom out are possible by turning the mouse wheel.
(This operation can also be performed using the + and - keys on the keyboard.)

Entire floor selection

When floor is selected using the mouse, all the indoor units and their R/C groups on the floor are selected.

Floor display mode

When Floor or Floor name is double-clicked using the mouse, the floor display mode is entered.
→ See par. 17-3-3 Monitoring in the floor display mode

③ **Unit icon:** The status of each unit can be checked.

Point to the unit icon.

When the cursor is set to a unit icon, the settings of that unit are displayed.

(In the building 3D display mode, the contents of the unit setting display cannot be changed.)

R/C group name	
Icon display (*1)	Set temperature Operation mode by background color
Temperature upper/lower limit setting	
R/C prohibited state	

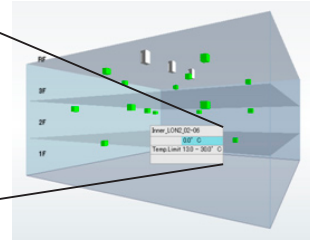

Outdoor Unit Group Name	
Icon display (*1)	Low noise schedule setting

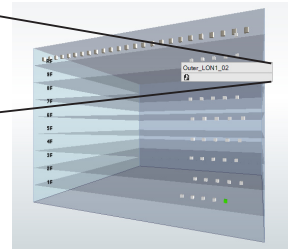

*1. Icon details



Schedule timer set



Filter sign on



Slave unit (*2)



Schedule timer setting invalid



Master unit



Slave unit by outdoor unit (*2)



Low noise schedule valid

*2. Cooling/Heating switching cannot be set for slave unit.



Low noise schedule invalid

For checking of operation mode by background color, see (a) Display color guidance.

Auto/Fan Cool/Dry Heat

Unit icon color

Displays the status of each unit by unit icon color.
See (a) Display color guidance.

3D Building display setting

Performs building 3D display setting. When [Display] of the tool icons is clicked, [Display Adjustment] window opens.

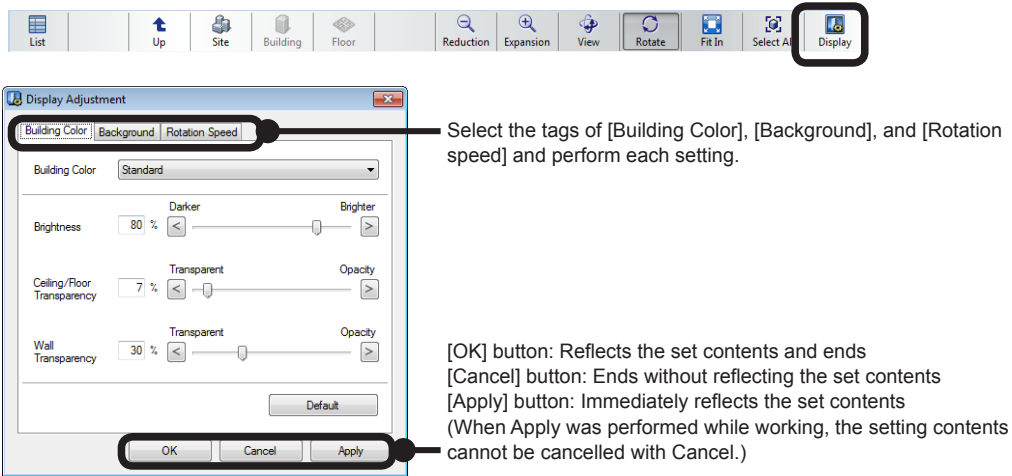

Building Color: The Building color can be adjusted.

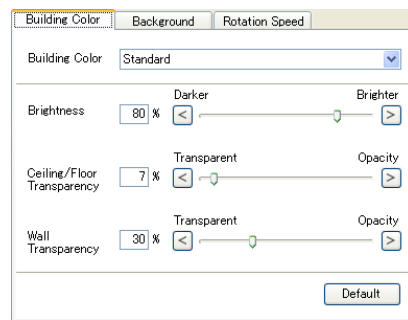

- Building Color
 - Brightness (100 to 0%)
 - Ceiling and Floor Transparency (100 to 0%)
 - Wall Transparency (100 to 0%)
- * The 3 items shown above can be set by text input, button input, and drag bar operation.
- [Default] button: Returns to standard setting.
- * If you change Building Color, the Brightness, Ceiling and Floor Transparency, and Wall Transparency values will change to their default values.

Background: The background can be set.

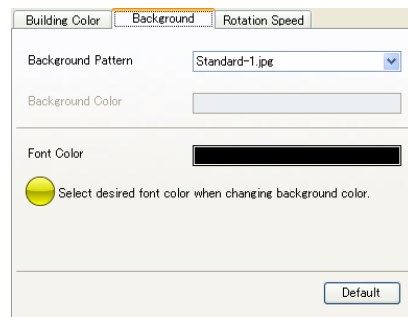

- Background Pattern selection
 - Background Color
 - Character Color
- * Set the character color to the color which is easiest to see against the background color.
- [Default] button: Returns to standard setting.

Rotation Speed: The Building rotation speed can be adjusted.

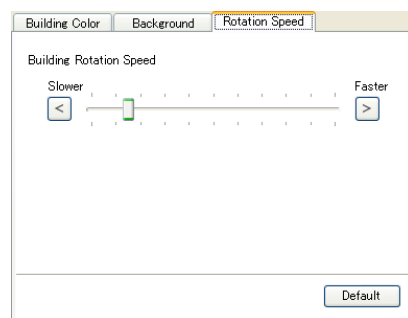

- Building Rotation Speed
- * Setting by button and drag bar operation is possible.
- [Default] button: Returns to standard setting.

17-3-3 Monitoring in the floor display mode

The units in the selected building are monitored by floor.
To display this screen, click [Floor] of the tool icons on the monitor screen.

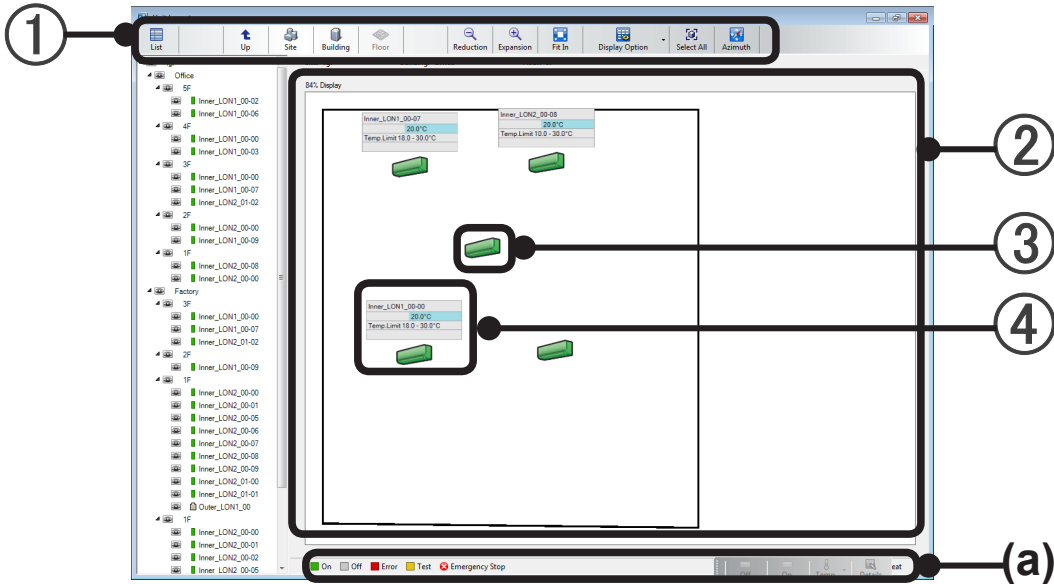
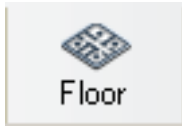

① **Tool icons:** Perform display contents switching, etc.



List	Switched to list display.	
Up	Each time the [Up] button is pressed, [Floor display] → [Building 3D display] → [Site display] and viewpoint are switched to wide range.	
Site	Switches to site display.	
Building	Switches to building 3D display.	
Reduction	Reduces and displays the ② layout view.	
Expansion	Expands and displays the ② layout view.	
Fit In	Displays an entire floor. (*Floor mode only)	
Display Option	Unit setting display items in ④ can be selected Select the necessary items from the pull-down menu.	
	Fixed Display	Also displayed when not pointing with the mouse
	Schedule	Displays schedule timer setting yes/no by icon.
	Filter	Displays filter sign by icon.
	Management	Displays the identification of master indoor unit and slave indoor unit by icon. (Cooling/Heating switching cannot be set for slave unit.)
	R.C. Prohibition	Displays the R/C prohibited state.
	Temperature Limit	Displays the set temperature upper/lower limit restriction state.
Select All	Selects all the units displayed by ② Layout view (list view).	
Azimuth	Displays the azimuth. When displayed, the button enters the pressed state.	

Note

When you want to refer to the building sunshine, etc., display the azimuth by clicking the [Azimuth] button of the ① Tool icons.

② **Layout view:** The status of the units on a floor can be checked.

Floor plan move

The entire floor plan can be moved by dragging the mouse using the left button.
(This operation can also be performed using the direction keys on the keyboard.)

Zoom

Zoom in and zoom out are possible by turning the mouse wheel.
(This operation can also be performed using the + and - keys on the keyboard.)

Floor hierarchy move

The display can be switched to the next higher layer by pressing the keyboard [PageUp] key.
The display can be switched to the next lower layer by pressing the keyboard [PageDown] key.



Note



When you want to display the entire floor in the layout view, click the [Fit In] button of the ① Tool icons.

③ **Unit icon:**

The status of each unit can be checked. See (a) Display color guidance.

Icon display example (Cassette type indoor unit on a floor display)

	On: Running
	Off: Stopped
	Error: Error signal received.

	Test: Testing
	Emergency Stop: Emergency stop signal received.

④ **Unit setting display:**

Displays the status of each unit.

When an R/C group is set, the status of only the master unit is displayed.

When the cursor is set to a unit icon in the mini-
mized state, the display zooms in.

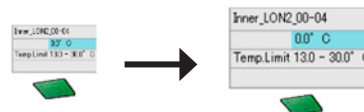

① The display contents can be selected using [Display Option] of the ① Tool icons.

R/C group name	
Icon display (*1)	Set temperature Operation mode by background color
Temperature upper/lower limit setting	
R/C prohibited state	

For checking of operation mode by background color, see (a) Display color guidance.

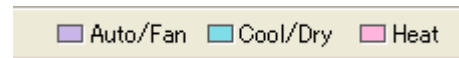

Outdoor Unit Group Name	
Icon display (*1)	Low noise schedule setting

*1. Icon details

Schedule timer set	Filter sign on	Slave unit (*2)
Schedule timer setting invalid	Master unit	Slave unit by outdoor unit (*2)
Low noise schedule valid		
Low noise schedule invalid		

*2. Cooling/Heating switching cannot be set for slave unit.

17-4 List display

Displays details of the R/C group/independent unit on the site in a list.
To display this screen, click [List] of the tool icons on the monitor screen.

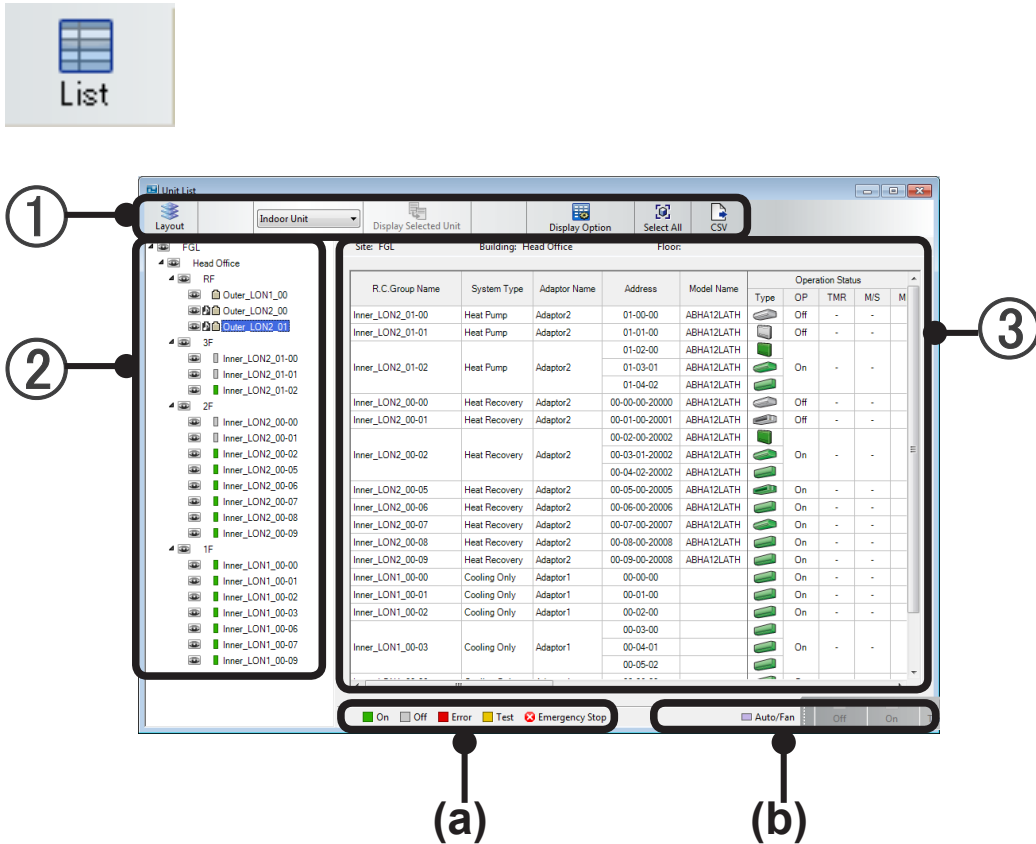

① Tool icons (list display)

Layout	Switches ③ "List display" to "Layout display".
Indoor Unit / Outdoor Unit (Switching by pull-down menu)	Switches the ③ "List display" screen to indoor unit display or outdoor unit display by pull-down menu.
Display Selected Unit	Displays only the R/C group selected in the ② "Tree display" on the ③ "List display" screen.
Display Option	Displays the display options setting screen that displays a list of setting items by pressing the "Display Option" button.
Select All	Selects all the units being displayed on the ③ "List display" screen. This is convenient in batch operation and setting.
CSV	Writes the contents of the ③ "List display" screen in CSV format.







② Tree display

Displays the groups and R/C groups on the site in tree format. The contents selected for each preset hierarchy and group and by R/C group are reflected at the ③ "List display" screen. For details, see par. 17-5 Tree display.

③ List display

The viewpoint selected at the ② "Tree display" and units in the group are displayed.
(Display is indoor units only or outdoor units only. Switch the display by ① Tool icon pull-down menu.)





Indoor unit display

Item	Display contents		System correspondence	
			S/V Series	V-II/J-II/VR-II Series
R.C.Group Name	Remote controller group name		○	○
System Type	Displays the type of refrigerant system (cooling only or heat pump).		○	○
Adaptor Name	Connected U10 USB Network Interface adaptor name		○	○
Address	Displays the address for each unit. "Refrigerant system address"- "Unit address"- "R/C address" or "Refrigerant system address"- "Unit address"- "R/C address"- "RBG No"		○	○
Model Name	Unit model name* *The letter ":" as the last letter of the Model Name signifies that the Model Name for the corresponding unit was written after shipment. The letter ":" is not part of the Model Name.		-	○
Operation Status	Type	Indoor unit icon. The status of each unit can be checked. See (a) Display color guidance	○	○
	Operation	Operation status. ON / OFF / Test	○	○
	Timer	Schedule timer set state.  Timer set  Timer setting invalid	○	○
	Master / Slave	Identifies master indoor unit and slave indoor unit by icon. (Cooling/Heating switching cannot be set for slave unit.)  Master unit  Slave unit  Slave unit by outdoor unit	-	○
	Maintenance	 Displays an icon during emergency stop and maintenance operation restriction.	○	○
	Filter	Displays the status of the filter sign by icon. For the icon → See par. 18-2 Detail operation.	○	○
Operation Mode	Displays the operation mode. (Displayed even when stopped.) Cool / Dry / Heat / Auto / Fan / "-" (S Series : Stop) (V Series : Stop) (V-II Series : Off) (J-II Series : Off) (VR-II Series : Off) Displays the background color during operation. See (b).		○	○
Set Temp.	Displays the set temperature.		○	○
Fan Speed	Displays the air flow setting. Auto/Low/Med/High/"-"		○	○
R.C.Prohibition	Displays the R/C prohibited state. For the icon → See par. 18-2 Detail operation.		○	○

Information		Displays the unit status.	Emergency Stop	○	○
			Pump Down	○	○
			Maintenance Mode	○	○
			Defrost	-	○
			Oil Recovery	-	○
			Mode Mismatch	○	○
Air Flow Direction	VT	Vertical Air Flow Direction setting	○	○	
	HT	Horizontal Air Flow Direction setting	○	○	
Temp. Limit*	Cool / Dry	Cool/Dry upper/lower limit temperature set value	-	○	
	Heat	Heat upper/lower limit temperature set value	-	○	
	Auto	Auto upper/lower limit temperature set value	-	○	
Economy		Energy-saving operation setting (S Series, V Series: Energy save V-II Series, J-II Series: Eco Mode)	○	○	
Anti Freeze		Anti Freeze setting	○	○	

* The background of the currently enabled mode becomes grey.

Outdoor unit display

Item	Display contents		System correspondence	
			S/V Series	V-II/J-II/VR-II Series
Outdoor Unit Group Name	Outdoor group name		○	○
System Type	Displays the type of refrigerant system (cooling only or heat pump)		○	○
Adaptor Name	Connected U10 USB Network Interface name		○	○
Address	Displays the address for each unit. Display contents: "Refrigerant system address"- "Unit address"		○	○
Model Name	Unit model name* *The letter ":" as the last letter of the Model Name signifies that the Model Name for the corresponding unit was written after shipment. The letter ":" is not part of the Model Name.		○	○
Operation Status	Type	Outdoor unit icons  Normal  Error signal received  Emergency stop signal received	○	○
	Status	Displays the outdoor unit status. (Normal/Error)	○	○
	TMR	 Low noise schedule set	○	○
		 Low noise schedule invalid		
— Low noise schedule not set				
Information	Displays the unit status.	Emergency Stop	-	○
		Maintenance Mode	-	○
		Defrost	○	-
		Oil Recovery	○	-

Note

- The data may not fit on the "List Display" screen depending on the contents. In this case, scroll the data using the scroll bar at the side of the screen.
- The operation mode and Air Flow Direction, Fan Speed, and other display contents may be different depending on the unit (model).

17-5 Tree display

Hierarchical display of a list of monitored groups and R/C groups.
Rapid movement to monitored units and selection is possible.

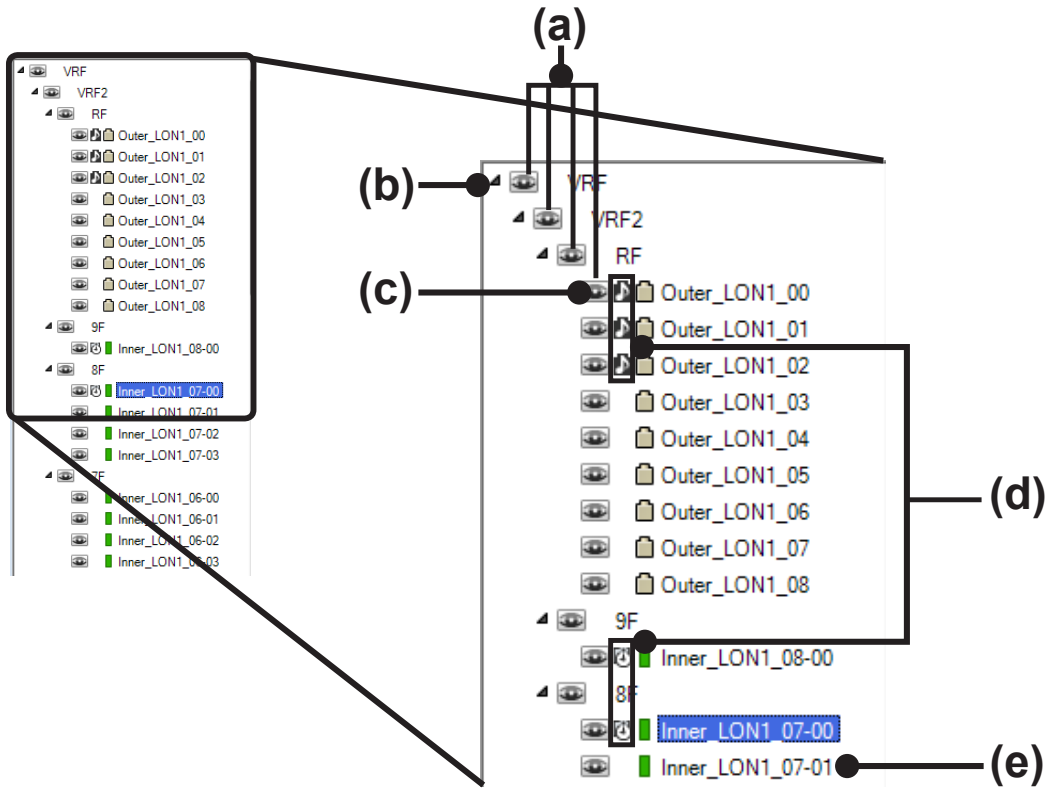

(a) Hierarchical display:

Group display having a hierarchy is possible by site, building, floor, and other group setting. A hierarchy by tenant, etc. can also be set. (Site setting only at highest hierarchy)
The contents of the tree display are different depending on the group setting.
For details, see par. 8-3-6 Group setting.

(b) Expansion (degeneration) mark:

Everything lower than the clicked hierarchy is not displayed.
It is displayed when clicked again.

Highest hierarchy (site) only displayed



2nd hierarchy only displayed
(building in the example in the figure)

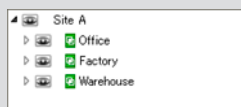

3rd hierarchy only displayed
(floor in the example in the figure)

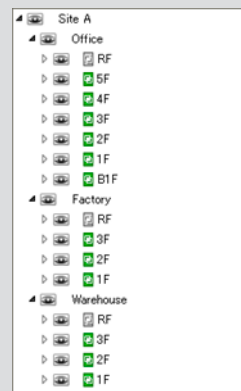



(c) View icon

When clicked, "Layout view" / "List view" is changed according to the selected hierarchy.

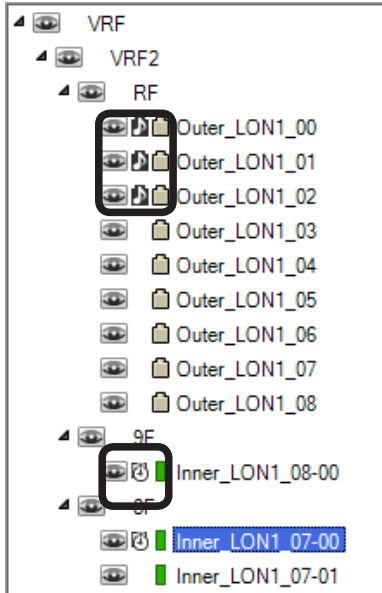

(d) Status display

Displays the timer setting and status of each unit in a tree display











No icon	Timer not set (*1)
	Timer set
	Timer setting invalid



*1. For a detailed description of timer setting, see par. 19. Schedule Operation.

No icon	Low noise schedule status (*1)
	Low noise schedule allocated
	Low noise schedule invalid

*1. For a detailed description of timer setting, see par. 23. Low Noise Operation.

	Indoor unit Running
	Running in group (*2)
	Indoor unit Stopped
	All stopped in group (*2)

	Indoor unit Error signal received
	Error signal received in group (*2)
	Indoor unit Testing
	Testing in group (*2)

	Outdoor unit
	Outdoor unit error signal received
	Emergency stop signal received

*2. Displayed when unit hierarchy was not displayed and when group setting is performed. (For a detailed description of group setting, see par. 8-3-6 Group setting.)

If even one unit in a hierarchy and group is in one of the states shown above, the icon color is changed and the icon is displayed. The priority order is 1: Emergency stop, 2: Error, 3: Test, 4: On, 5: Off.

(e) Tree item

When clicked, all the units in the selected hierarchy are selected.

Batch operation and setting are performed.

(*Switch the layout view by (c) View icon.)

Note

- Tree view may not be displayed on the screen depending on the contents. In this case, scroll the display using the scroll bar at the side of the screen.

Tree item selection

Click the character (tree item) of site, building, floor, and unit in the tree display. The units corresponding to clicked tree item are selected.

Select the highest hierarchy.

(The screen is a site display.)

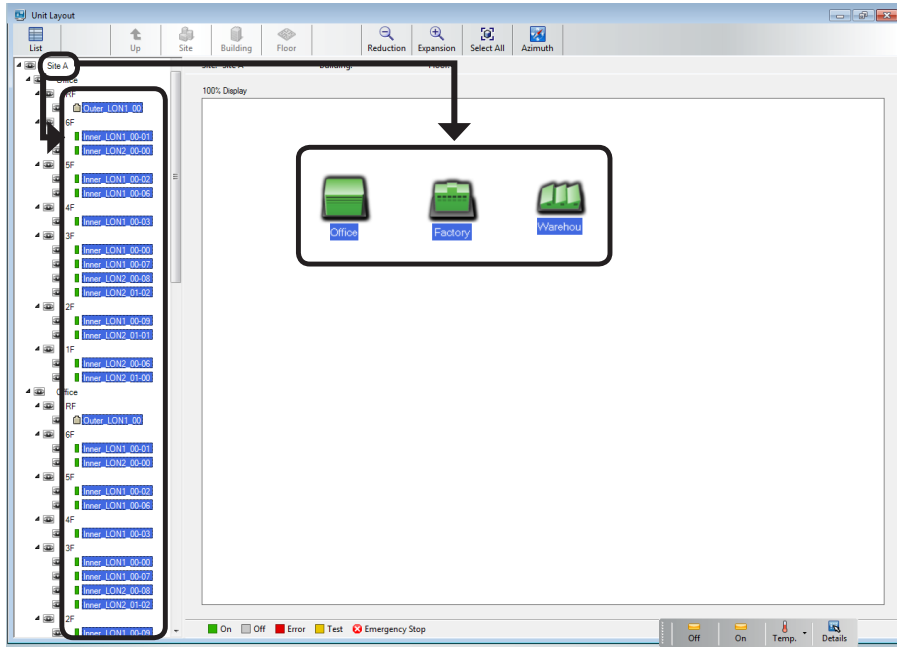

All the units on the corresponding site are selected.

Select the hierarchy corresponding to building.

(The screen is a building 3D display.)

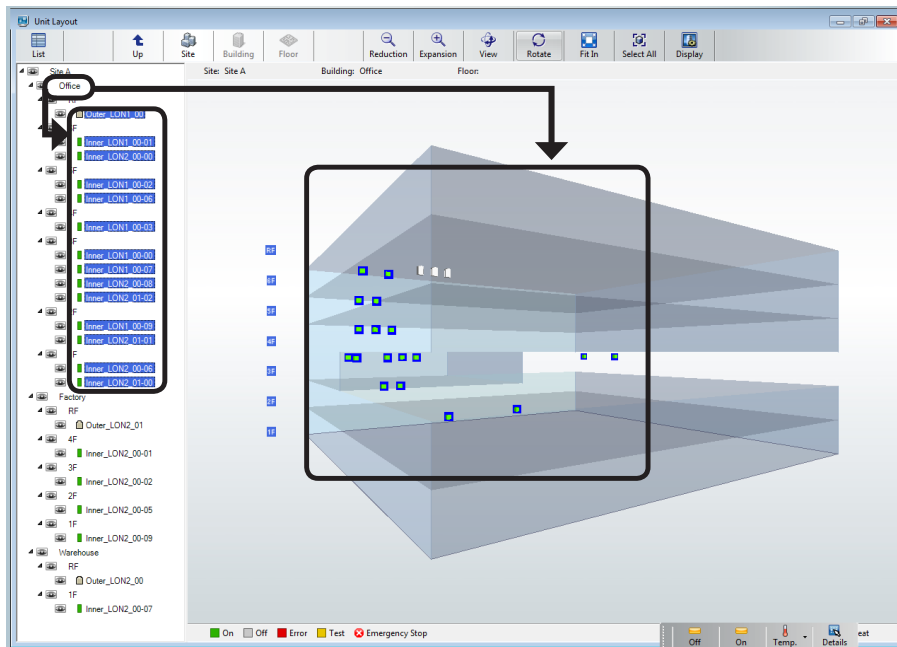

All the units in the corresponding building are selected.

Select the hierarchy corresponding to floor.

(The screen is a building 3D display.)

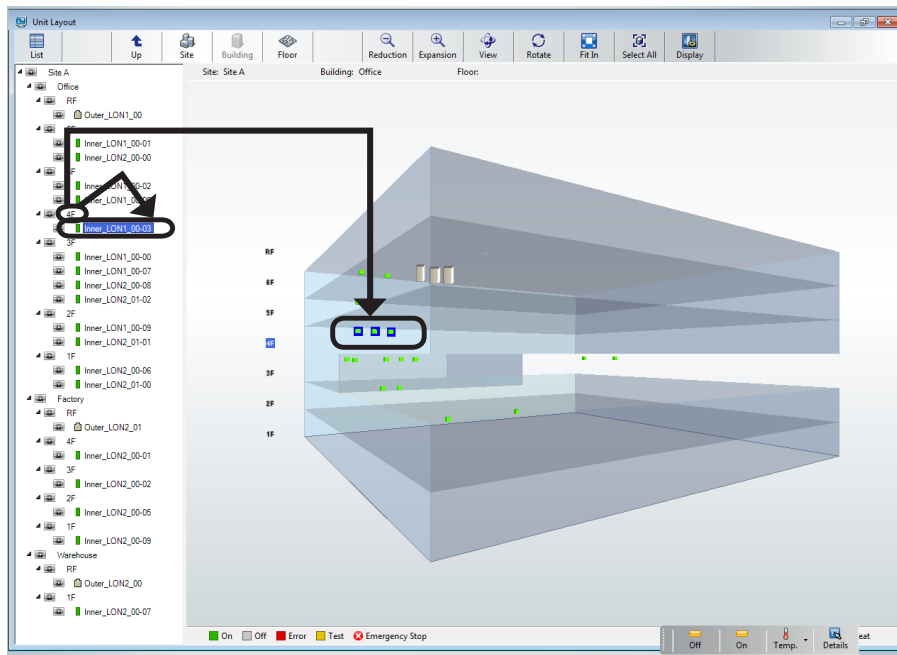

All the units on the corresponding floor are selected.

Select the end item.

(The screen is floor display.)

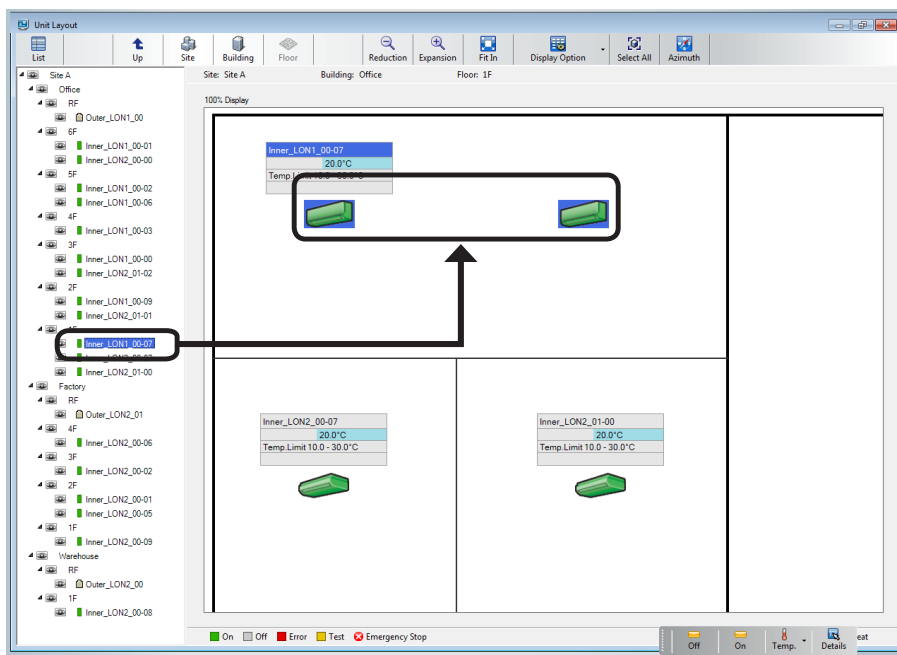

All corresponding units (R/C group, outdoor unit) are selected.

Note

Display switching is not linked to "Tree Item" selection. When you want to display all the selected "Tree Items", switch the display with the "View Icon" corresponding to the "Tree Item". When the displayed hierarchy is lower than the selected hierarchy, it may not be possible to check selection of all the units. In this case, since a Groups out of view window is displayed, check out of view units here. (For details, see par. 17-2-1 Monitor screen.)

Selection of hierarchy corresponding to floor by List display

(The screen displays the hierarchy corresponding to building.)

The screenshot shows the VRF-System Controller interface. On the left, a tree view shows the hierarchy of units, with the 4F floor units selected. On the right, a table displays the details of these units. A black box highlights the selected units in the table, and a black arrow points from the tree view to the table.

R.C.Group Name	System Type	Adaptor Name	Address	Model Name	Operation Status			
					Type	OP	TMR	MIS
Inner_LON1_02-00	Cooling Only	V2	02-00-00	ARXB18LALH	Off	-	-	-
Inner_LON1_02-01	Cooling Only	V2	02-01-00	ARXB18LALH	Off	-	-	-
Inner_LON1_02-02	Cooling Only	V2	02-02-00	ARXB07LALH	Off	-	-	-
Inner_LON1_02-03	Cooling Only	V2	02-03-00	ARXB18LALH	Off	-	-	-
Inner_LON1_02-04	Cooling Only	V2	02-04-01	ARXB07LALH	Off	-	-	-
Inner_LON1_01-00	Cooling Only	V2	01-00-00	ARXB18LALH	Off	-	-	-
Inner_LON1_01-01	Cooling Only	V2	01-01-00	ARXB18LALH	Off	-	-	-
Inner_LON1_01-02	Cooling Only	V2	01-02-00	ARXB07LALH	Off	-	-	-
Inner_LON1_01-03	Cooling Only	V2	01-03-00	ARXB18LALH	Off	-	-	-
Inner_LON1_01-04	Cooling Only	V2	01-04-01	ARXB07LALH	Off	-	-	-
Inner_LON1_00-00	Cooling Only	V2	00-00-00	ARXB18LALH	On	-	-	-
Inner_LON1_00-01	Cooling Only	V2	00-01-00	ARXB18LALH	Off	-	-	-
Inner_LON1_00-02	Cooling Only	V2	00-02-00	ARXB07LALH	Off	-	-	-
Inner_LON1_00-03	Cooling Only	V2	00-03-00	ARXB18LALH	Off	-	-	-
Inner_LON1_00-04	Cooling Only	V2	00-04-01	ARXB07LALH	On	-	-	-
Inner_LON2_03-00	Cooling Only	V1	03-00-00	ARXB18LALH	On	-	-	-
Inner_LON2_03-01	Cooling Only	V1	03-01-00	ARXB18LALH	On	-	-	-
Inner_LON2_03-02	Cooling Only	V1	03-02-00	ARXB18LALH	On	-	-	-

All the units on the floor are selected

17-7 Display Option setting

Selects the items you want to display on the “Unit List” screen.

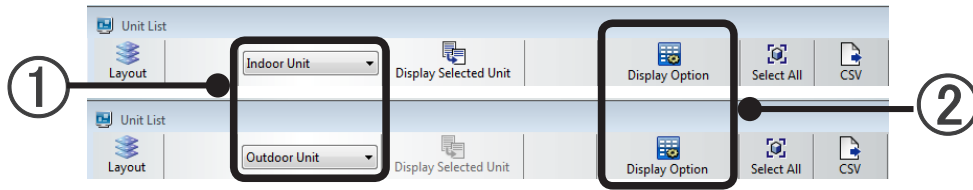

- ① To set [Indoor Unit] display items, select [Indoor Unit] and to set [Outdoor Unit] display items, selected [Outdoor Unit].
- ② Press the [Display Option] button. The “Display Option” screen opens.

“Display Option” display (Indoor Unit)

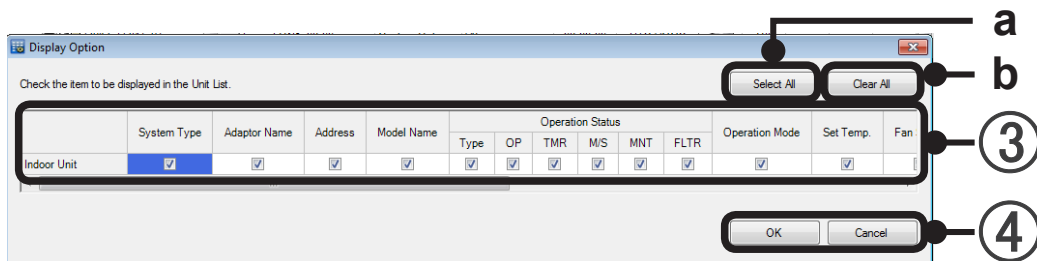

“Display Option” display (Outdoor Unit)

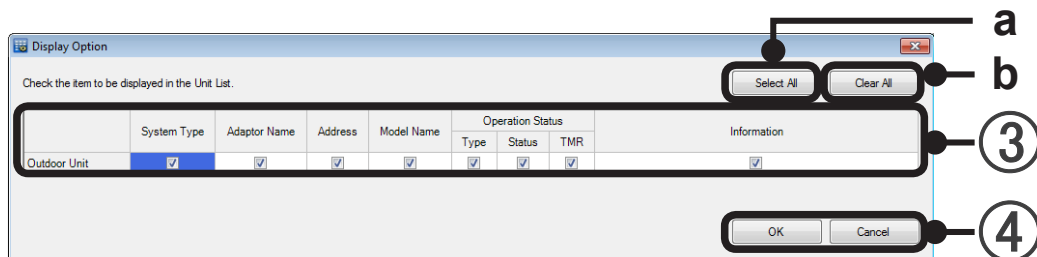

- ③ Check the items you want to display on the “Unit List” screen.
 - a [Select ALL]: Checks all the items.
 - b [Reset All]: Unchecks all the items.
- ④ [OK]: Reflected at the “Unit List” screen in realtime.
[Cancel]: Ends setting without saving the edited contents.

Note

When the energy saving option (UTY-PEGX) is used, an “Energy Saving” item is added to the menu.

18. Operation Control

Operation control is possible only by users given the Operation Control right.

18-1 Quick operation

Operation ON-OFF, temperature setting, and other frequently used operations are performed easily. There are 2 quick operation methods: by right click menu and by control pad.

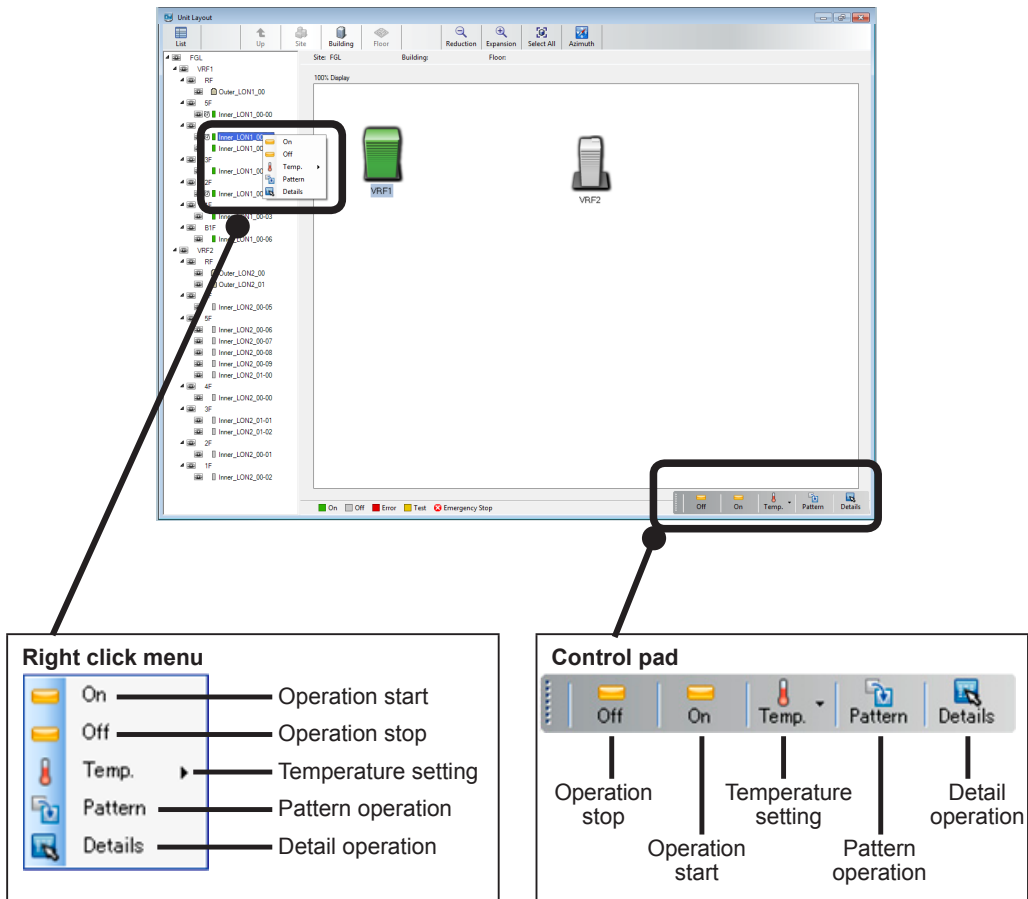

Quick Operation is performed by selecting an R/C group and using right click menu or control pad. The R/C group selection method varies depending on the displayed screen mode.

- Site Monitor Mode: Building units selection
- 3D Building Mode: Floor units selection, R/C group units selection
- Floor: R/C group units selection
- List: R/C group units selection

All selections can also be made by tree view.

Turning operation ON.

- ① Select the R/C group (individual, group) to be controlled.

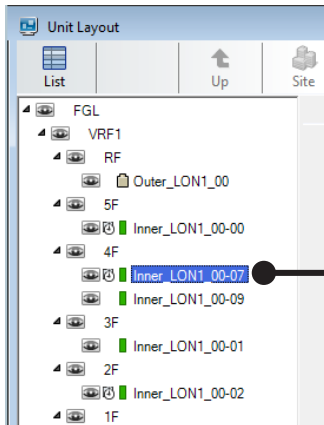

The figure is an example of a tree view.

- ② Display the right click menu by right clicking the mouse.

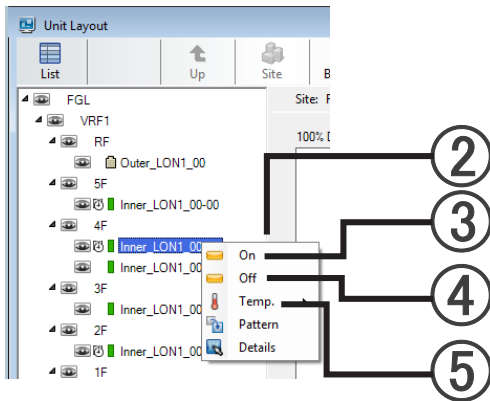

- ② When using control pad

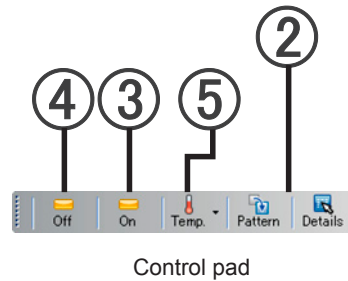

Control pad

- ③ When [On] is selected, operation starts.

Turning operation OFF.

- ① Select the R/C group (individual, group) to be controlled.
- ② Display the right click menu by right clicking the mouse or using the control pad.
- ④ When [Off] is selected, operation stops.

Changing the set temperature

- ① Select the R/C group (individual, group) to be controlled.
- ② Display the right click menu by right clicking the mouse or using the control pad.
- ⑤ When [Temp] is selected, the settable temperature is displayed.

With the S Series and V Series, select that temperature. With the V-II Series, J-II Series, when the displayed temperature is pointed to, a more detailed settable temperature is displayed. Select the temperature

The selected temperature is set.

- * For energy saving measures and other reasons, when upper/lower temperature limits are set, the temperature can only be set within that set range.

Performing pattern operation

- 1 Select the R/C group (individual, group) to be controlled.

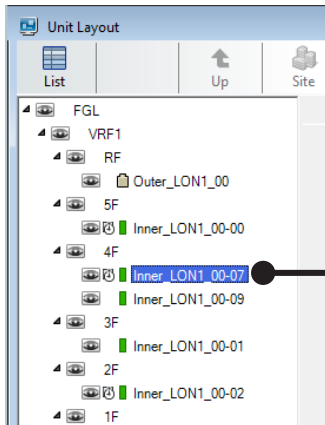

The figure is an example of a tree view.

- 2 Display the right click menu by right clicking the mouse.

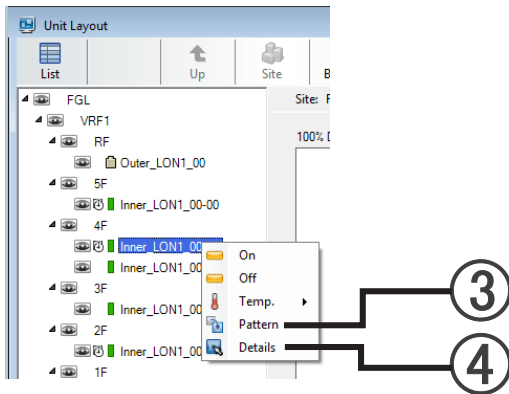

- 2 When using control pad

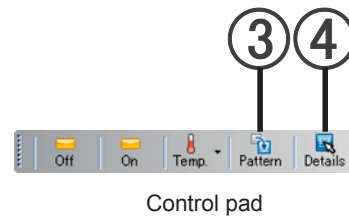

- 3 Select [Pattern].

The operation of R/C group is set in accordance with a pattern registered at the system controller in advance.

- * If a pattern is not registered, [Pattern] is not displayed.
→ See par. 18-2-1 Basic operation

Performing detail operation

- 1 Select the R/C group (individual, group) to be controlled.
- 2 Display the right click menu by right clicking the mouse or using the control pad.
- 4 Select [Detail].
An Operation Setting screen opens.

→ See par. 18-2 Detail operation

18-2 Detail operation

Indoor unit detail operation control is performed. To display this screen:

- R/C group selection and right click menu →[Detail]
- R/C group selection and control pad →[Detail]
- R/C group selection and main screen menu → "Operation" → "Operation Setting"

18-2-1 Basic operation

Description of Operation Setting screen

At display, the current operation status of the selected R/C group is displayed.

When multiple R/C groups are selected, if the displayed details of each item are "Mixed", they will be displayed in a mixed way.

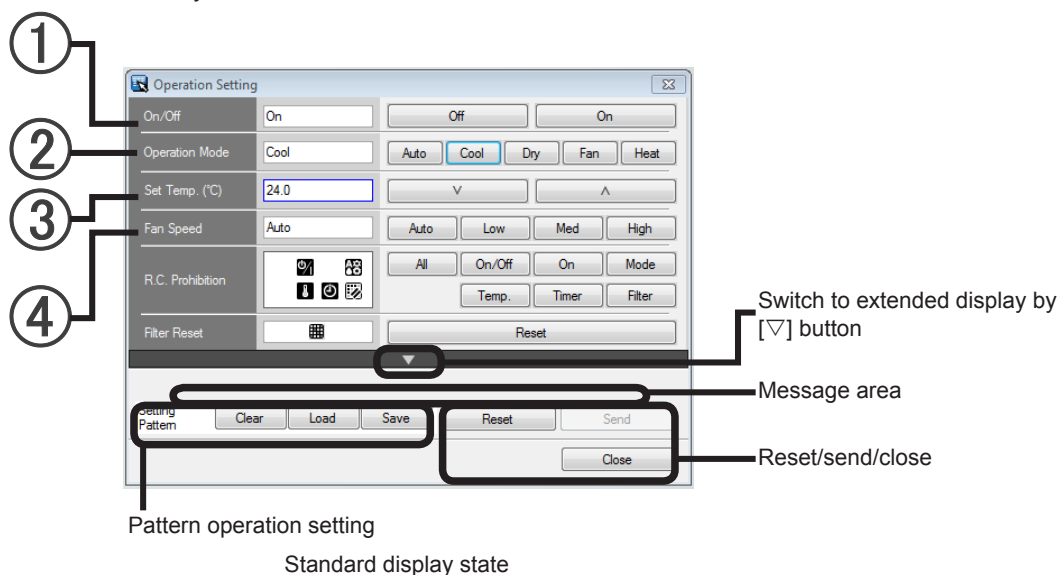

① On/Off

Operation start/operation stop

② Operation Mode

Operation mode switching

Auto/Cool/Dry/Fan/Heat

* There are other indoor unit operation status and operation modes which cannot be set depending on the System Type. For details, see "About operation mode" on P.194.

③ Set Temp

Temperature setting

Set by direct numeric input or [v] and [^] buttons.

With the S Series and V Series, setting in 1 degree increments is possible.

With the V-II Series and J-II Series setting in 0.5 degree increments is possible.

* When upper and lower temperature limits were set; temperature setting is possible only within that set range.
→ See par. 18-2-2 Extended operation (upper/lower temperature limits setting item)

④ Fan Speed

Fan speed switching

Auto/Low/Med/High

* For "Auto" details, see "About the Auto setting of fan speed" on P.195.

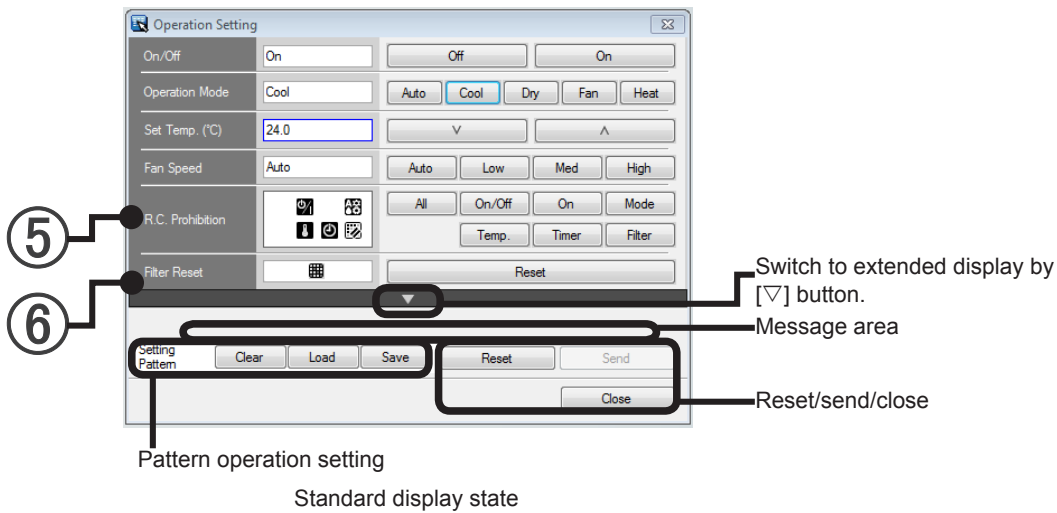

⑤ R.C Prohibition

R/C prohibition: Restricts operation from R/C.

- All: All operations prohibited
- On/Off: Operation start/operation stop prohibited
- On: Operation start prohibited *V-II Series and J-II Series
- Mode: Operation switching prohibited
- Temp: Temperature setting prohibited
- Timer: Timer prohibited
- Filter: Filter reset prohibited

⑥ Filter Reset

Displays filter sign on/off and resets filter sign (elapsed time).

Display contents

- Filter sign
- "Blank" No filter sign

Note

When operation is performed and reflected at a unit, always click [Send].
 If the settings are not sent, operation will not be reflected at the unit.
 When multiple R/C groups were selected, the settings are sent only to the settable units.

Pattern operation setting Clear/Load/Save

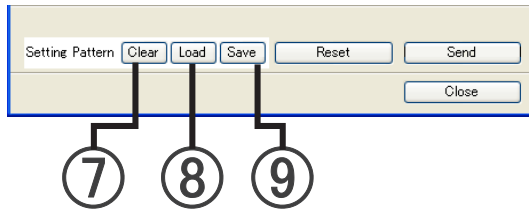

Performs operations related to the operation setting pattern of frequently used patterns.

- ⑦ [Clear] button
Erases the contents of a saved operation setting pattern.
- ⑧ [Load] button
Loads the set contents of a saved operation setting pattern.
It is reflected at the current Operation Setting screen.
- ⑨ [Save] button
Saves the setting contents of the current Operation Setting screen as frequently used operation setting pattern. (*1)

Note

*1. Only 1 setting can be saved as operation setting pattern. The setting contents previously saved are erased.

Reset/Send/Close

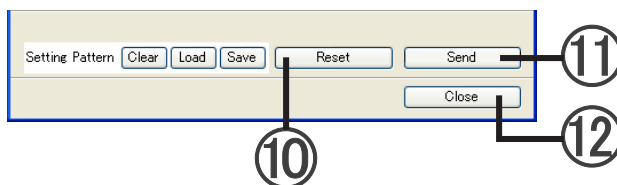

Resets or sends the setting contents of the Operation Setting screen and ends Operation Setting.

- ⑩ [Reset] button
Clears the entered setting contents and acquires and displays the current operation status.
When "Mixed" is displayed, it shows the mixed state.
- ⑪ [Send] button
Sends the setting contents of only the set items to the target unit
Items not set are not sent.
- ⑫ [Close] button
Ends Operation Setting.
(This does not send the setting contents to the target unit.)

About operation mode

AUTO ..COOLING MODEL

- When the room temperature is 2 °C(4°F) higher than the set temperature ,the operating status will switch between Cooling and Drying.
- During the Drying mode operation, the FAN setting should be switched to LOW for a gently cooling effect during which the fan may temporarily stop rotating.
- If the mode automatically selected by the unit is not satisfactory, see above and change the mode setting (COOL, FAN).

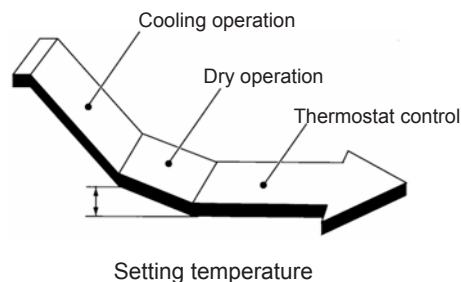

AUTO (AUTO CHANGE OVER) ..HEAT&COOL MODEL (Reverse cycle)

- When AUTO CHANGE OVER is selected, the air conditioner selects the appropriate operating status (Cooling or Heating) according to the real room temperature.
- When AUTO CHANGE OVER is first selected, the fan will operate at very low speed for about one minutes while the unit determines the current conditions of the room and accordingly selects the proper operation mode.
- When the air conditioner has adjusted the room temperature to near the thermostat setting, it will being monitor operation. In the monitor operation mode, the fan will operate at low speed. If the room temperature subsequently changes, the air conditioner will select the appropriate operation (Heating, Cooling) once again to adjust the temperature to the value set with the thermostat. (The monitor operation range is ± 2 °C(± 4 °F) relative to the thermostat setting.)
- If the mode automatically selected by the unit is not satisfactory, see above and change the mode setting (HEAT, COOL, FAN).
- Do not select AUTO CHANGE OVER if the difference in the environmental temperature of the master and slave units is over 2 °C(4°F). (Otherwise, the indoor fan may not be controlled correctly.)

Heating

- Use to warm your room.
- When Heating mode is selected, the air conditioner will operate at very low fan speed for about 3 to 5 minutes, after which it will switch to the selected fan speed setting. This period of time is provided to allow the indoor units to warm up before a full operation.
- When the room temperature is very low, frost may form on the outdoor unit, therefore, the performance of the outdoor unit will decrease. In order to remove such frost, the unit will automatically enter the defrost cycle from time to time. During defrosting, the heating mode will be temporarily interrupted "DEFROST" will be shown on the remote controller display.

Cooling

- Use to cool your room.

Fan

- Use to circulate the air throughout your room.

Cooling/Heating priority:

When a HEAT PUMP TYPE operating system is used, the system can only be performed in one of 2 operation modes (cooling/heating) for single refrigerant system. When an indoor unit in the system first starts an heating operation, the system is then in "Heating priority". This means the system will refuse a command for changing the operation mode.

On the other hand, when an indoor unit in the system first starts a cooling operation, the system is then in "Cooling priority". The system will refuse to change to any other operation mode, except for the drying operation.

About the AUTO setting of fan speed

Heating:

Fan operates so as to optimally circulate warmed air. However, the fan will operate at very low speed when the temperature of the air issued from the indoor unit is low.

Cooling:

As the room temperature approaches that of thermostat setting, the fan speed becomes slower.

Fan:

The fan alternately turns on and off; when the fan turns on, it rotates at a low fan speed.

- The fan will operate at a very low speed during the monitor operation by which the room Temperature is deleted.

18-2-2 Extended operation

Sets the extended operation for detail operation of the air conditioner.

The extended operation screen is displayed from the Operation Setting screen by [▽] button.

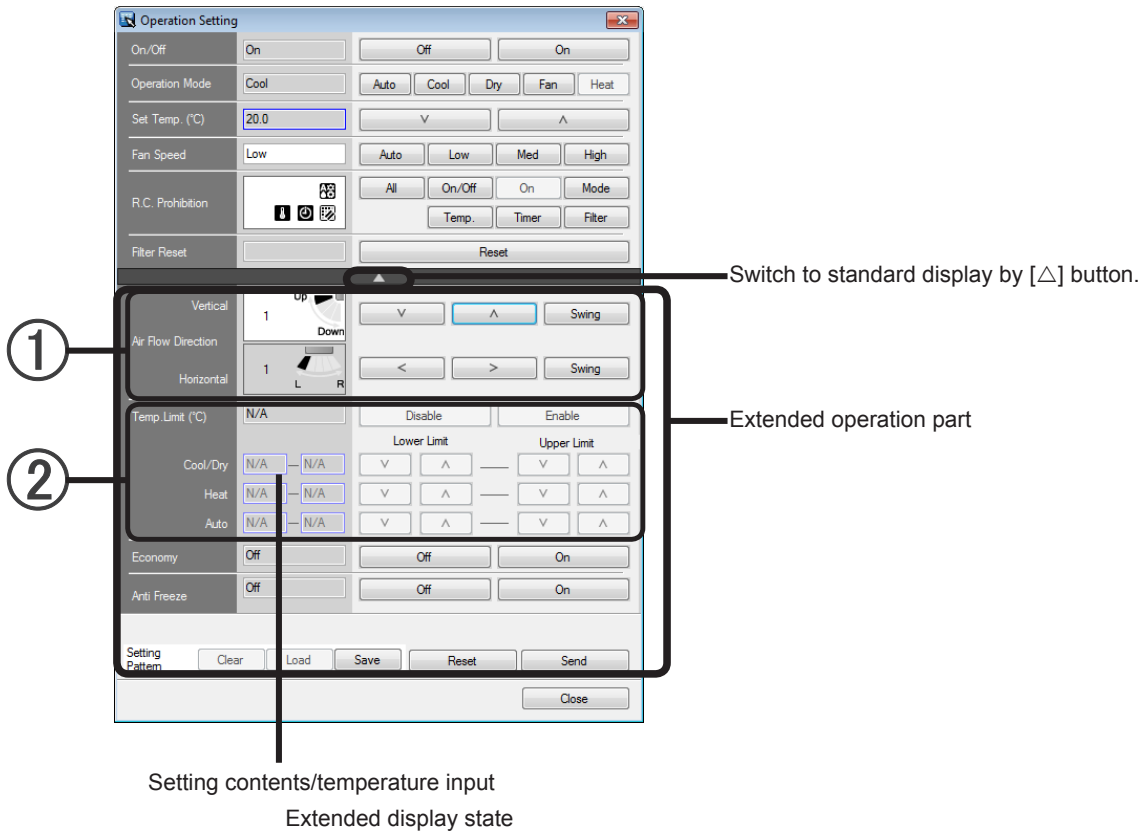

① Air Flow Direction setting

Sets the Air Flow Directions.

1. Set an arbitrary angle using the [v], [^], [<], and [>] buttons.

To set to automatic, select [Swing].

Louver Vertical: Vertical Air Flow Direction setting

Louver Horizontal: Horizontal Air Flow Direction setting

* When Air Flow Direction setting is disabled, N/A is displayed and setting is impossible.

② Upper/lower temperature limits setting

When upper/lower temperature limits setting is performed, "Set Temp." can only be changed within that set range.

Perform upper/lower temperature limits setting.

1. Click [Enable] button.
2. Enter the set temperature range in the modes of Cool, Dry, Heat, and Auto.
Set by direct numeric input or by [v] and [^] buttons. (0.5 degree increments)
Upper limit: Upper limit set temperature
Lower limit: Lower limit set temperature

* Only the necessary modes can be set.

Setting is possible only with of the V-II Series and J-II Series.

Cancel upper/lower temperature limit setting.

Click [Disable] button.

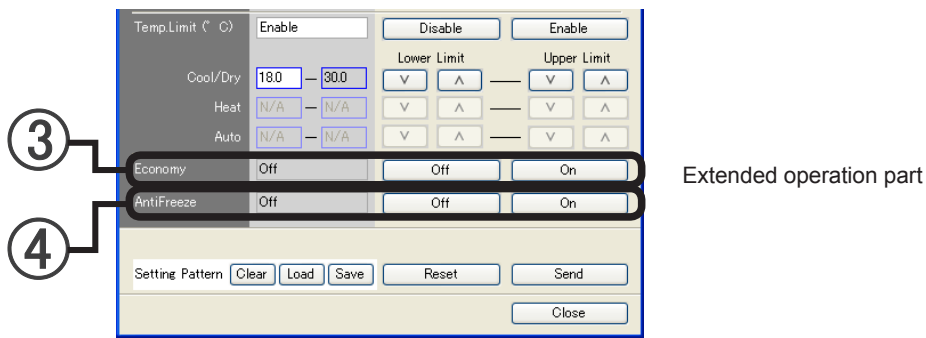

③ Economy operation

Economy operation can be set by remote controller.

The temperature setting is offset automatically over a certain period of time.

Based on temperature set in remote control unit, temperature of indoor unit varies little by little. However in this case, temperature indication of remote control unit does not vary as it continues to indicate the temperature when ECONOMY Operation was set.

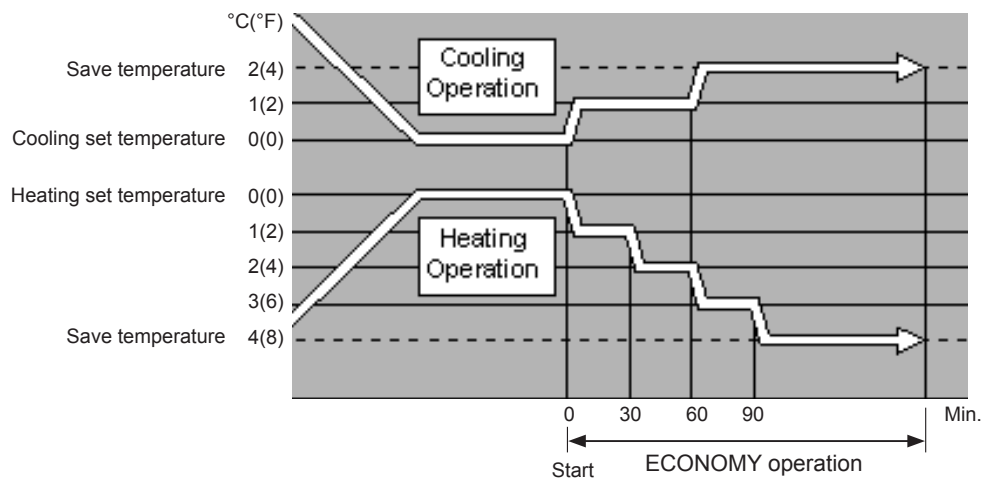

[On] button

Sets economy operation

* Energy Save mode for S Series and V Series
Economy mode for V-II Series and J-II Series

[Off] button

Cancels the economy operation setting.

④ Anti Freeze

This function performs low temperature warm-up operation to prevent trouble by freezing of the water pipes and equipment when air conditioning operation was stopped in cold regions.

[On] button

Sets Anti Freeze.

[Off] button

Cancels the Anti Freeze settings.

Note

When operation is performed and reflected at a unit, always click [Send].

If the settings are not sent, operation will not be reflected at the unit.

When multiple R/C groups were selected, the settings are sent only to the settable units.

18-3 Memory operation

This operation loads and reflects the saved operation pattern for the selected R/C group (multiple groups can be selected).

Operation settings for each group or each R/C group can be saved and reproduced by simple operation.

18-3-1 Load operation pattern

Operates according to an operation pattern saved in advance

- ① Select the R/C group. (*1)

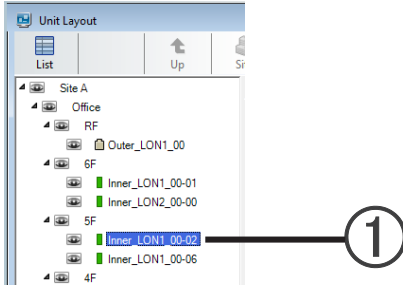

- ② From the main screen menu, select "Operation" → "Memory Operation" → "Load Operation".

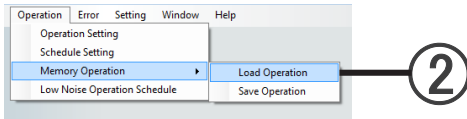

- ③ The currently saved operation pattern contents are displayed. (*2)

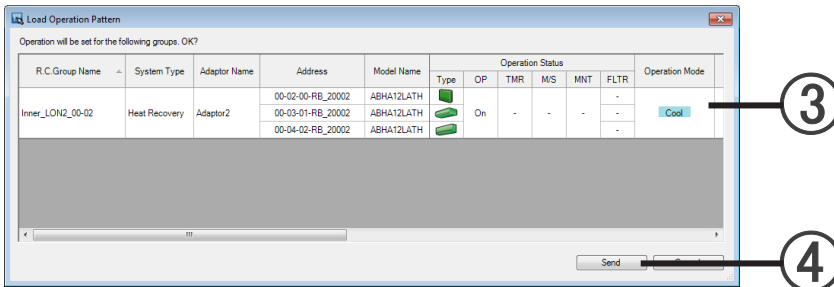

- ④ If the loaded contents are okay, click the [Send] button.
The operation pattern is sent to the unit.

Note

- *1. When selecting R/C groups, selection is simple if performed while pressing the keyboard Shift key to select consecutive groups and while pressing the keyboard Ctrl key when selecting random groups
- *2. When nothing is saved, the current operation status is displayed.

18-3-2 Save operation pattern

Saves the current operation pattern.

- ① Select the R/C group. (*1)

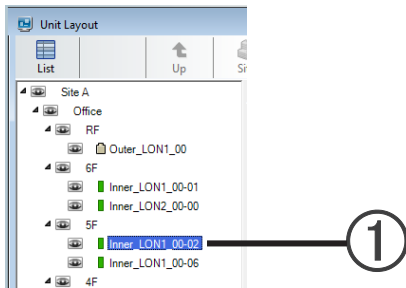

- ② From the main screen menu, select "Operation" → "Memory Operation" → "Save Operation".

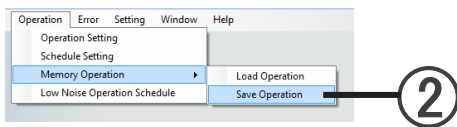

- ③ The current operation pattern is displayed.

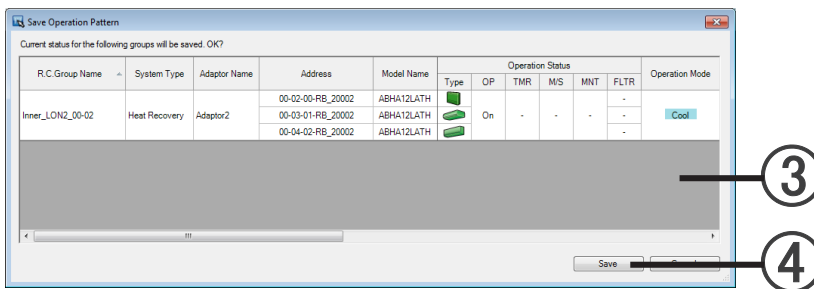

- ④ When the [Save] button is pressed, the current operation pattern is saved at the selected R/C group. (*2)

Note

- *1. When selecting R/C groups, selection is simple if performed while pressing the keyboard Shift key to select consecutive groups and while pressing the keyboard Ctrl key when selecting random groups.
- *2. Only 1 pattern can be saved. The previously saved operation pattern is erased.



19. Schedule Operation

19-1 Schedule Setting screen

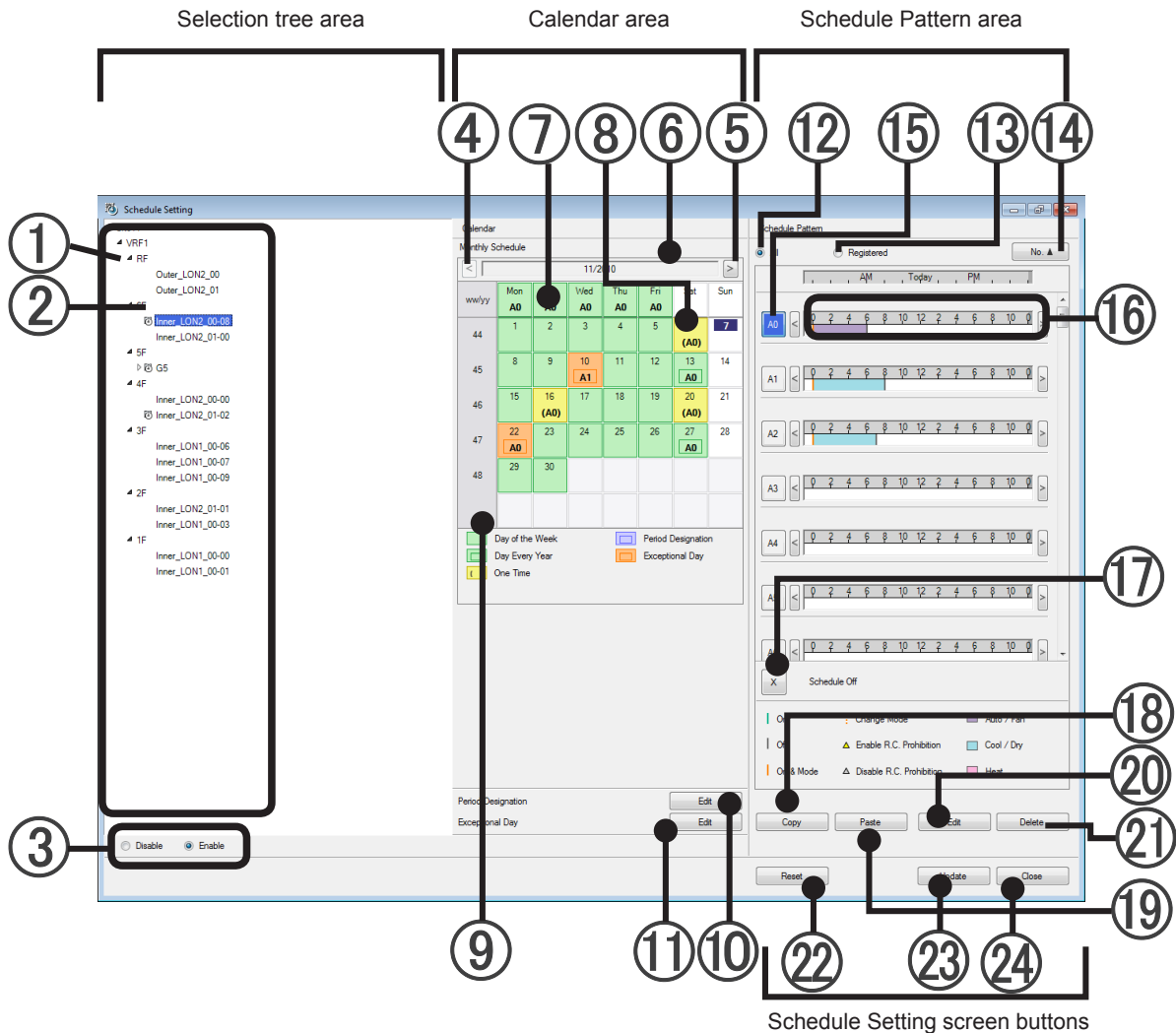



Indoor unit operation schedules can be set in group and R/C group units.
 To display this screen, click main screen menu → "Operation" → "Schedule Setting".



Selection tree area

① Selection tree	Selects the R/C group which is the target of schedule setting.
② Icon	None: Schedule not set  : Schedule set  : Different schedule set at R/C groups in a group  : Schedule disabled
③ Enable/Disable button	Enable or disables the schedule of the selected R/C group.

Calendar area

④ Back button	Moves the displayed calendar to the preceding month. Does not return to the previous month from the current month.
⑤ Next button	Moves the displayed calendar to the next month. Advances up to 12 months, including the current month.
⑥ Set month and year	Displays the month and year to be set.
⑦ Day of week setting	Performs setting in day of week units.
⑧ Date setting	Sets the date.  Day every year  One time  Period Designation  Not set  Exceptional day
⑨ Week number	Displays the number of the week in the year. Displays only calendars beginning from Monday. *1
⑩ Period Designation	Opens the Set Period settings screen. →Refer to Setting Period in 19-5.
⑪ Exceptional day button	Opens an Exceptional Day Setting screen. → See par. 19-6 Exceptional day setting

Note

- *1. The first day of the calendar is determined by the Windows® region setting at the time of installation. The first day of the calendar cannot be changed after installation.

Schedule pattern area

⑫ All button	Displays all the patterns (including those not set)
⑬ Registered button	Displays only the set patterns.
⑭ No. button	Switches the ascending/descending order of the displayed patterns.
⑮ Pattern selection button	When selected, assignment to a calendar and pattern setting are possible.
⑯ Schedule bar	Displays the pattern contents by color. Can be scrolled to both sides using the [<] and [>] buttons.
⑰ Off button	When assigned to the calendar, the Off day can be set.
⑱ Copy button	Copies the selected pattern.
⑲ Paste button	Pastes the copied pattern to the selected pattern.
⑳ Edit button	Edits the selected pattern. (Pattern Setting screen opens.)
㉑ Delete button	Deletes the selected pattern

Schedule Setting screen buttons

㉒ Reset button	Deletes the new contents and returns to the original contents.
㉓ Update button	Reflects the set schedule.
㉔ Close button	Closes the Schedule Setting screen. The contents being changed are discarded.

Note

Always update the calendar after setting/changing a schedule.
If not updated, the set/changed contents will not be reflected.

19-2 Overview (flow) of schedule operation creation

The following is the basic operating procedure when setting an operation schedule.

Operation flow

- 1 Create an operation pattern (Schedule Pattern)
→ See par. 19-3 Operation pattern creation

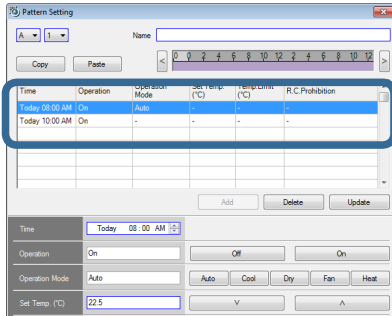

- 2 Select the schedule operation target.
Site, building, floor, or other group or R/C group.
→ See par. 19-4-1 Selection of schedule operation target

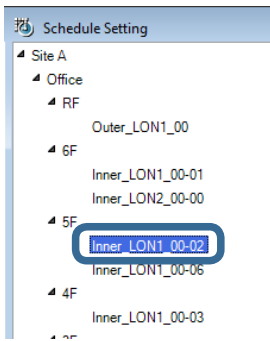

- 3 Assign an operation pattern to the calendar.
Operation pattern assignment → See par. 19-4-2,3 Assigning operation pattern to calendar
19-4-4 Assigning the OFF day on the calendar
Exceptional day setting → See par. 19-6 Exceptional day setting

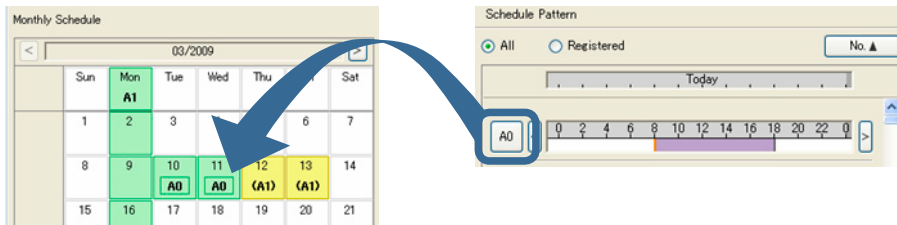

- 4 At the end of setting, update the calendar.
→ See par. 19-4-5 Calendar updating

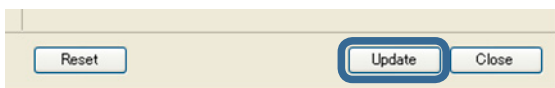

19-3 Operation pattern creation

Creates an operation pattern (Schedule Pattern).

48hours (2 days) operation control of indoor units in group and R/C group units is possible. (Max 100 patterns)

19-3-1 Pattern Setting screen

To display this screen, click the [Edit] button in the Schedule Pattern area of the Schedule Setting screen.

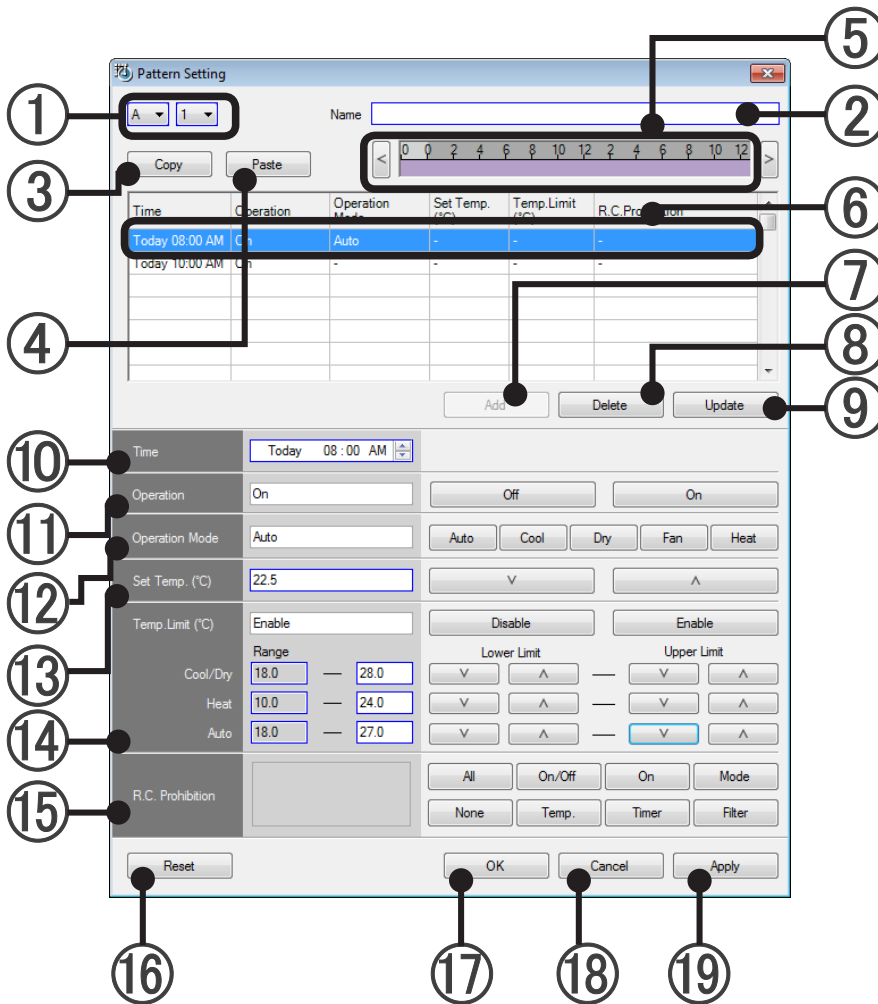

① No. setting button	The pattern number can be set. In addition, the pattern can be edited by selecting a set pattern.
② Pattern name	A name can be set for pattern. (Within 20 characters of alphabet and numeric)
③ Copy button	Copies the pattern selected with ①.
④ Paste button	Pastes the pattern copied with ③ to the pattern selected with ①.
⑤ Schedule bar	Displays the pattern contents by color. Can be scrolled to both sides using the [<] and [>] buttons.
⑥ Time pattern	Displays the control setting contents at the set time.
⑦ Add button	Adds the time pattern newly set with ⑩ to ⑮.

⑧ Delete button	Deletes the time pattern selected with ⑥.
⑨ Update button	Reflects the contents corrected with ⑩ to ⑮ at the time pattern.
⑩ Operation time	Sets the time pattern control time.
⑪ Operation	Sets operation start/operation stop.
⑫ Operation mode switching	Sets the operation mode to Auto, Cool, Dry, Fan, or Heat. Depending on the system type, and other mode, it may not be possible to normally reflect the operation mode setting.
⑬ Temperature setting	Set by direct numeric input or with the [v] and [^] buttons. When upper/lower temperature limits are set, the temperature can only be set within that set range.
⑭ Upper/lower temperature limits setting	When upper/lower temperature limits setting is performed, the set temperature can only be set within that range.
⑮ R/C prohibition	Restricts operation from R/C.
⑯ Reset button	Deletes the contents being set and returns to the contents before the set contents were changed. This button is effective only if pressed before the [Add]/[Update]/[Apply] button is pressed.
⑰ OK button	Reflects the set operation pattern and closes the setting screen.
⑱ Cancel button	Closes the setting screen. The contents being changed are discarded.
⑲ Apply button	Reflects the set operation pattern.

19-3-2 Overview of operation pattern creation

Schedule Setting screen

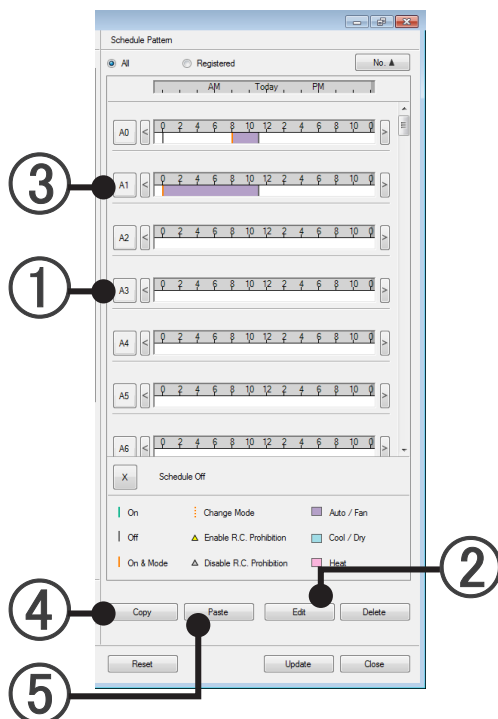

New pattern

- ① Select a pattern for which an operation pattern is not set.
- ② Click the [Edit] button.

Correction

- ③ Select the pattern to be corrected.
- ② Click the [Edit] button.

Using a duplicate

- ③ Select the pattern to be duplicated.
- ④ Make a copy by pressing the [Copy] button.
- ① Select the duplication destination.
- ⑤ When the [Paste] button is clicked, the copy is pasted to the duplication destination.
- ② Click the [Edit] button.

Pattern Setting screen

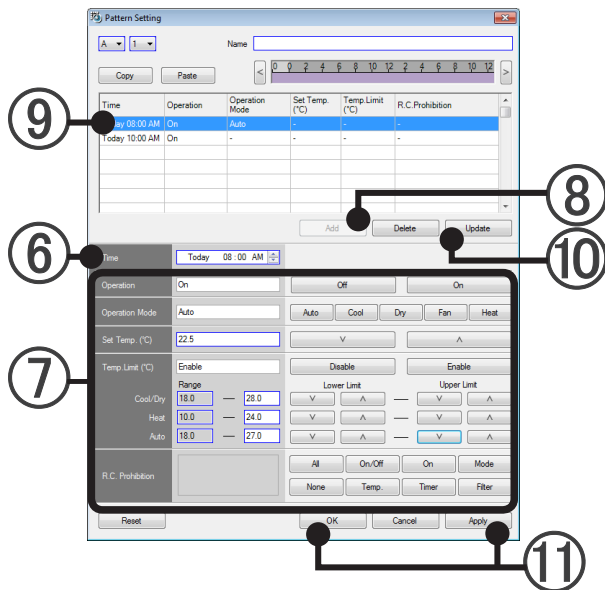

Pattern Setting screen opens.

Creating a new time pattern

- ⑥ Set the control start time.
- ⑦ Make the necessary operation settings.
→ See par. 19-3-3 Operation pattern setting items
- ⑧ At the end of the necessary operation settings, click the [Add] button.
- ⑨ Check that the pattern was added to the time pattern.

Editing a time pattern

- ⑨ Click the time pattern you intend to edit.
- ⑥ The set start time is displayed.
- ⑦ The setting state is displayed. Perform editing.
- ⑩ At the end of editing, click the [Update] button.
- ⑪ At the end of setting, click one of the following buttons:
[OK] button: Saves the set contents and closes the Pattern Setting screen.
[Apply] button: Saves the set contents. The Pattern Setting screen remains unchanged.

Note

When Start/Stop, operation mode setting, room temp. setting, fan speed setting, air flow direction setting, swing setting, economy mode, and anti freeze setting are changed frequently by using the central controller like BMS, system controller, touch panel controller, etc., the number of operations for each indoor unit must not exceed 7,500 times/year.

If the number of setting change exceeds the above specified number, the rewriting frequency of the EEPROM (built into the air conditioner and used for setting memory) will be exceeded, and may cause breakdown.

19-3-3 Operation pattern setting items

Operation pattern setting items

Operation time input (Essential)

Select "Today" or "Next" at "Today" item and set by using the up/down buttons at the right side. Select the hour digit at the "Time" item and set the hour by entering the numbers directly or by using the up/down buttons on the right side. Next, select the minute digit and set the minutes by entering the numbers directly or by using the up/down buttons at the right side. Minutes are in 10 minute units. Input in 1 minute units is invalid, even if performed. When "AM" or "PM" is displayed, select the item and set by using the up/down buttons at the right side.

- Operation time input is essential, but set the following items as required.

Operation start/stop

To start operation, select [On] and to stop operation select [Off].
To use the air conditioner continuously during operation, leave the setting as it is.

Operation mode switching

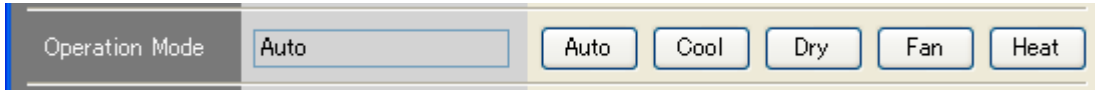

Select the operation mode to be set.

Depending on the System Type, etc, there may be operation modes which cannot be set.

When not performing operation mode switching, leave the setting as it is.

Temperature setting

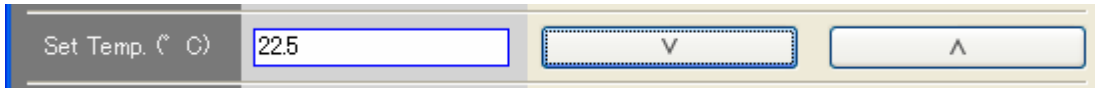

Set an arbitrary temperature from the [v] and [^] buttons.

Direct numeric input is also possible. Input the temperature after making the selections inside the blue frame.

(S Series: 1.0°C units, V series: 1.0°C, V-II Series: 0.5°C units, J-II Series: 0.5°C units)

The room temperature setting range is within the set upper/lower temperature limits range.

When the room temperature is not to be changed, leave the setting as it is.

Upper/lower temperature limits setting

The temperature setting operable range in each operation mode can be set for V-II Series and J-II Series.

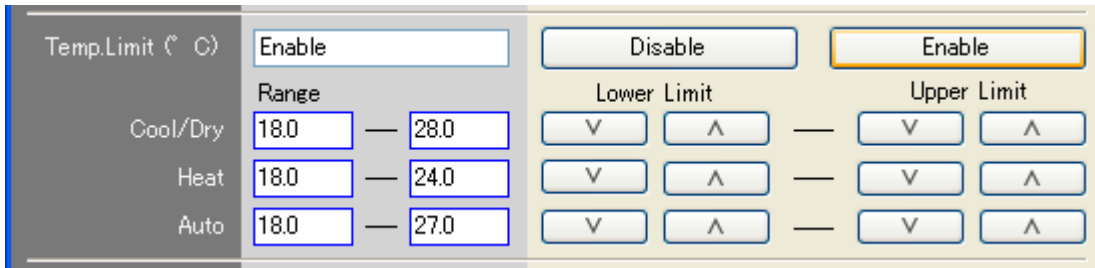

Set an arbitrary temperature range from the [v] and [^] buttons. The temperature range can be set in 0.5°C units.

Direct numeric input is also possible. Make the selections inside the blue range to be input and input in 0.5°C units.

Upper limit only or lower limit only can also be set.

To enable upper/lower limits setting, select [Enable].

To disable upper/lower limits setting, select [Disable].





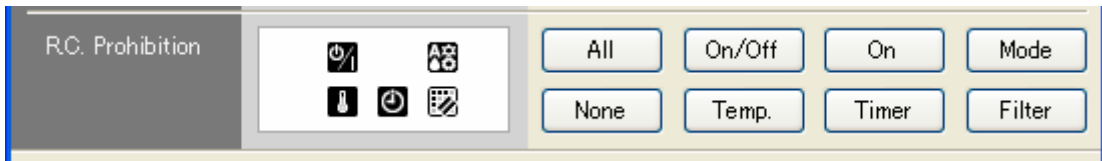

When the upper/lower limits setting is not changed, leave the setting as it is.

R/C prohibition

Restricts operation from R/C.



Selects operations which are not to be accepted from R/C.

-  All: All prohibited
-  On/Off: Operation start/stop prohibited
-  On: Operation start prohibited *V-II Series and J-II Series.
-  Mode: Mode switch prohibited
-  Temp.: Temperature setting prohibited
-  Timer: Timer prohibited
-  Filter: Filter reset prohibited

The prohibition setting is switched each time each button is clicked.
Do not set when the R/C prohibition setting is not changed.

19-4 Pattern assignment to calendar

19-4-1 Selection of schedule operation target

- 1 Select the schedule operation target.
Selectable targets are site, building, floor, and other groups or R/C groups.

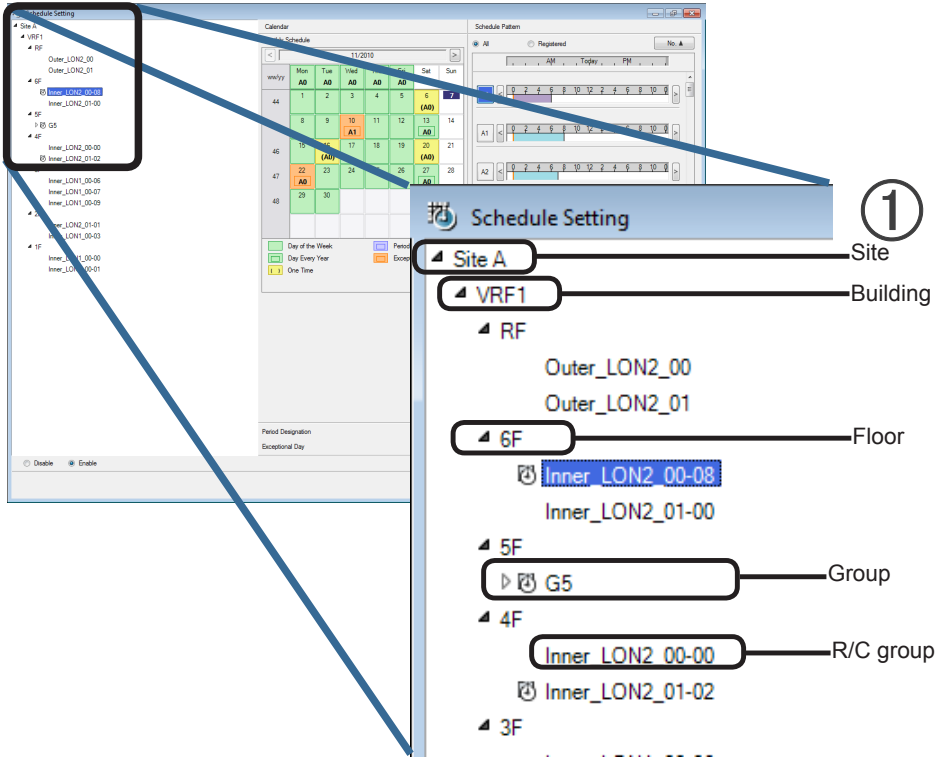

Note

If there is an R/C group with a different schedule set in a group, a schedule cannot be set at that group.

To set up schedules in ascending order

Example) Group A

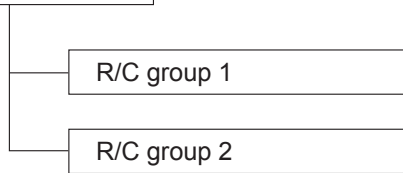

When a different schedule is set at R/C group 1 and R/C group 2, a schedule cannot be set at Group A.

Now then, when a different operation pattern is assigned to a group within a group or an R/C group (e.g. building → floor → group → R/C group) after a common pattern was previously pasted to the group (e.g. site), an entire schedule can be set using very few steps.

19-4-2 Assigning operation pattern to calendar (daily)

- 1 Select the operation pattern.

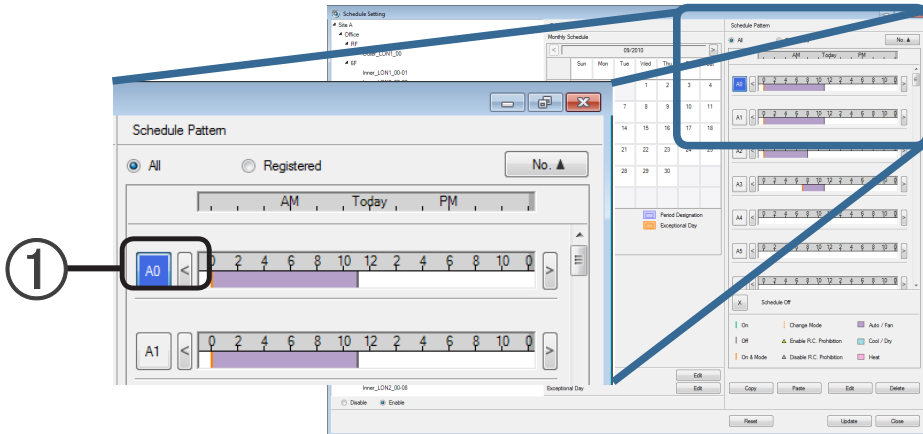

- 2 Assign the operation pattern to a calendar.

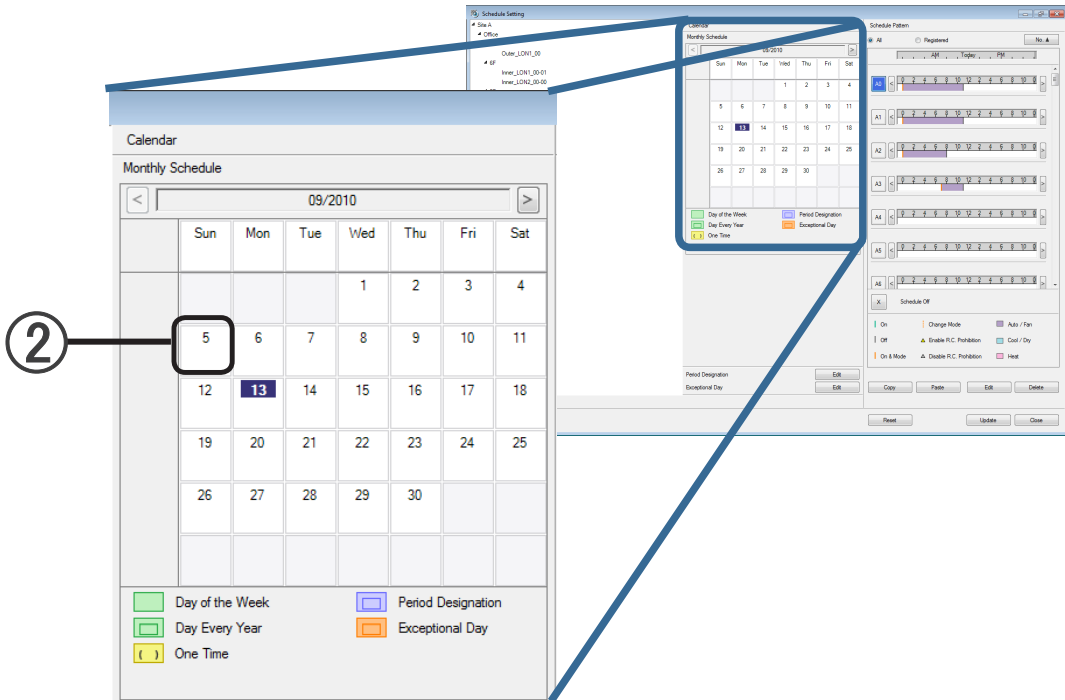

- 3 Operation pattern registration varies depending on the number of clicks.

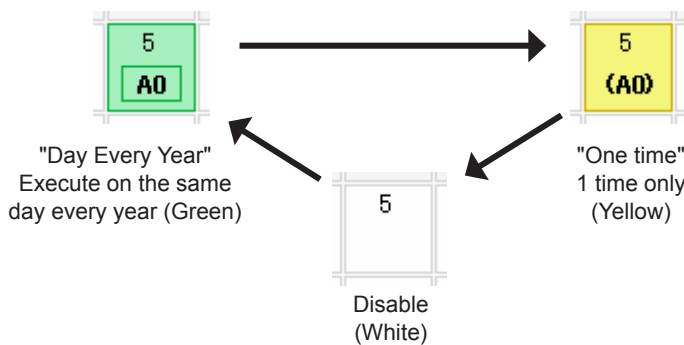

19-4-3 Assigning operation pattern to calendar (every day of week)

- 1 Select the operation pattern.

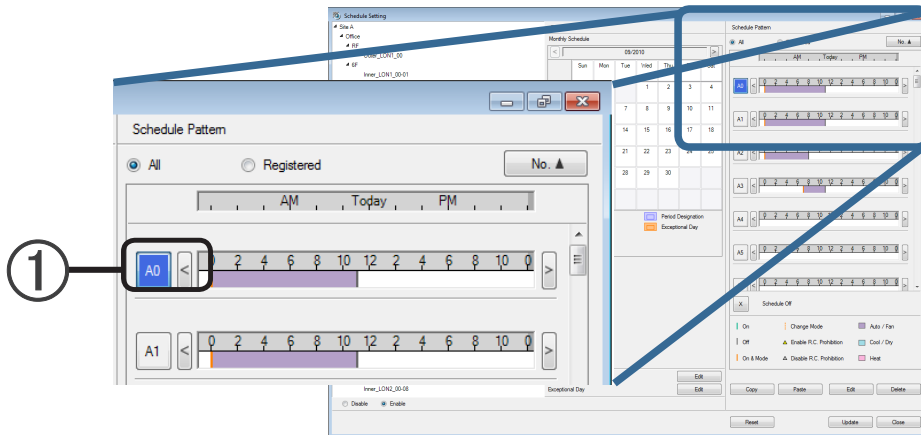

- 2 Assign the operation pattern to a day of week calendar.

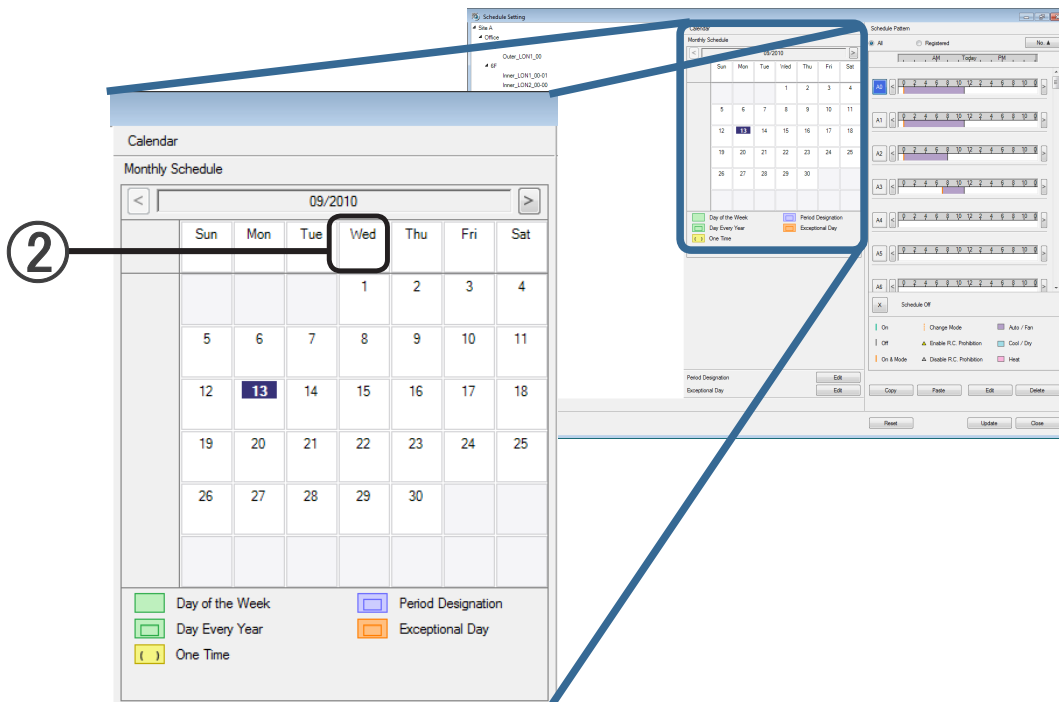

- 3 Operation pattern registration varies depending on the number of clicks.

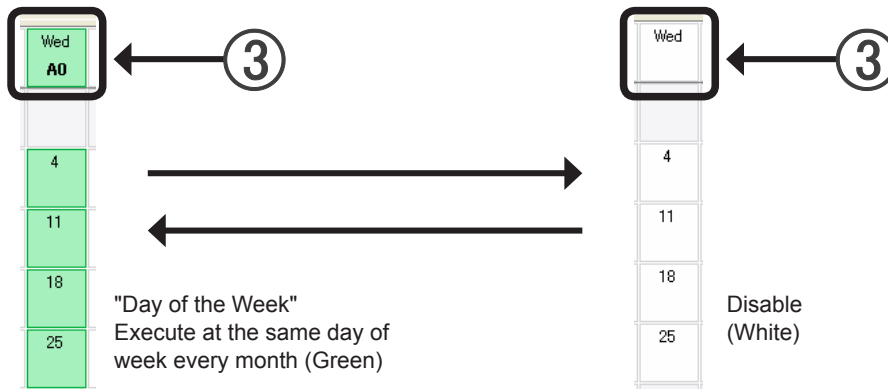

19-4-4 Assigning the OFF day on the calendar

- 1 Select "Schedule Off".

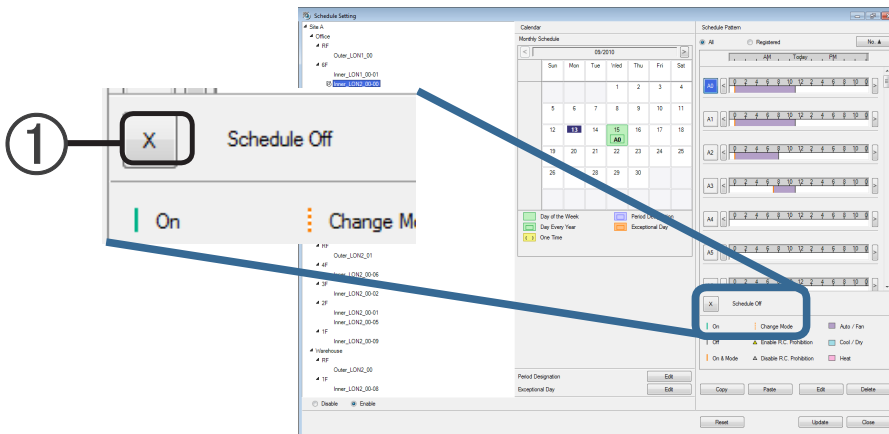

- 2 Assign the OFF day on the calendar.

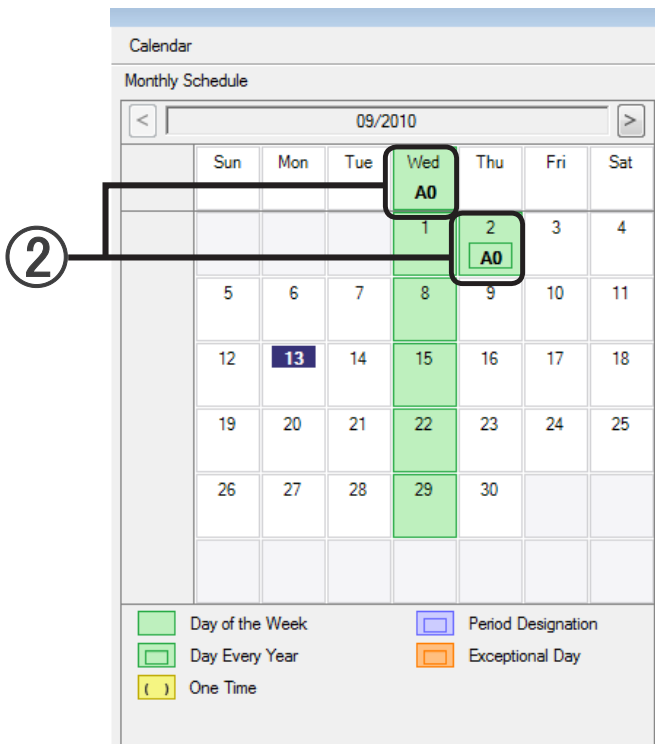

- Date can be cancelled by repeated clicking.

→ 19-4-2 Assigning operation pattern to calendar (daily)

However, when set by day of week, operation pattern assignment cannot be canceled by repeated clicking.

Operation method at tree area

Copy, Paste, and Delete of schedules set by group and R/C group can be performed at the selection tree area.

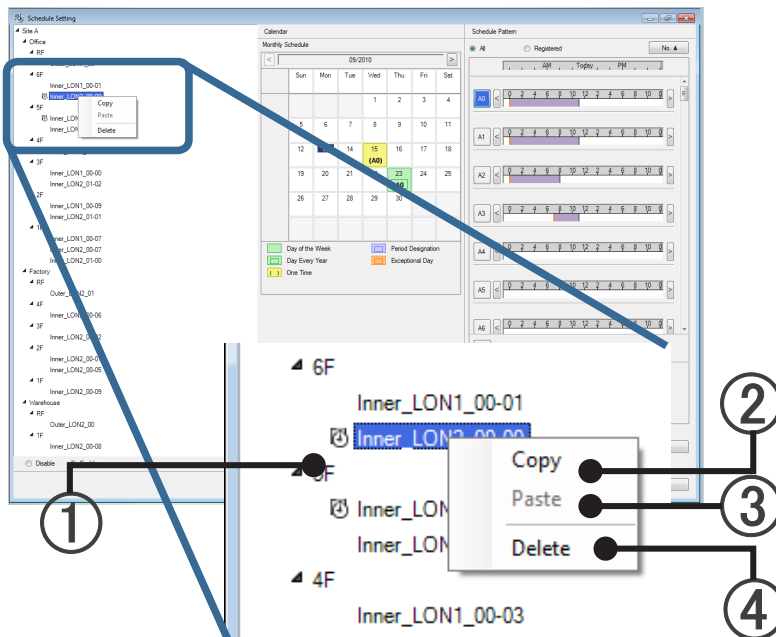

Copying schedule set at group (R/C group) to another group (R/C group)

- ① Select the group (R/C group) with the schedule you want to copy at the selection tree area.
- ② Right click the mouse and select [Copy].
- ① Select the copy destination group.
- ③ Right click the mouse and select [Paste].
The schedule is pasted.

Deleting a schedule set at a group (R/C group)

- ① Select the group (R/C group) with the schedule you want to delete at the selection tree area.
- ④ Right click the mouse and select [Delete].
The schedule is deleted.

19-4-5 Calendar updating

Update the calendar when a schedule is set.

- 1 Click the [Update] button to update the schedule.

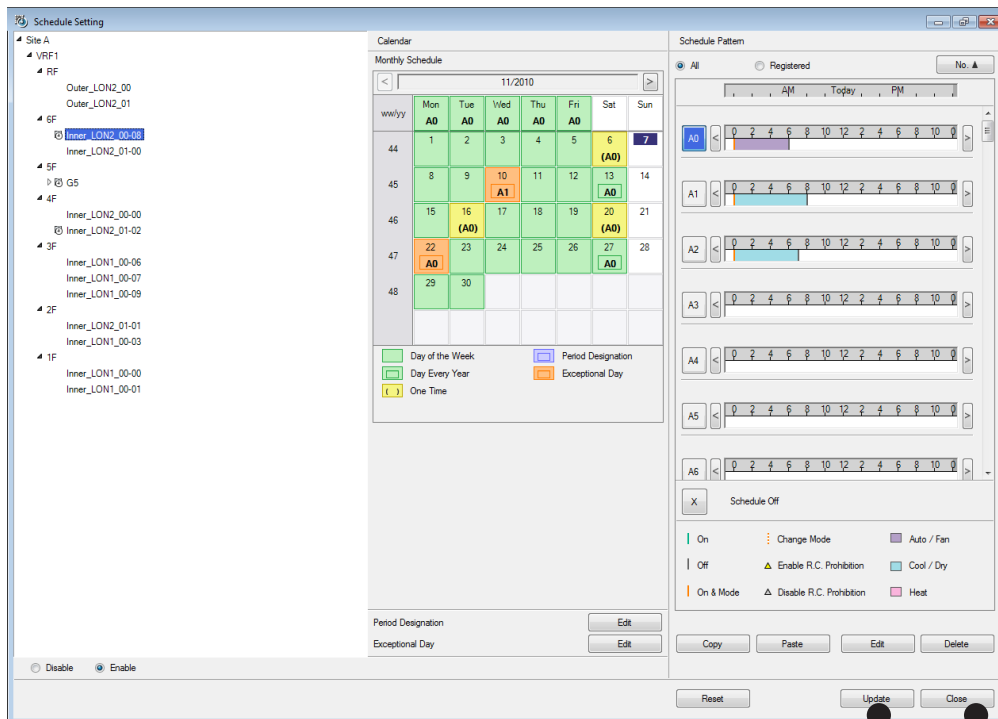

- 2 When the [Close] button is clicked, the Schedule Setting screen is closed.

19-5 Period Setting

You can set the period and allocate it to a calendar. The settings will also carry over into the next year and later.

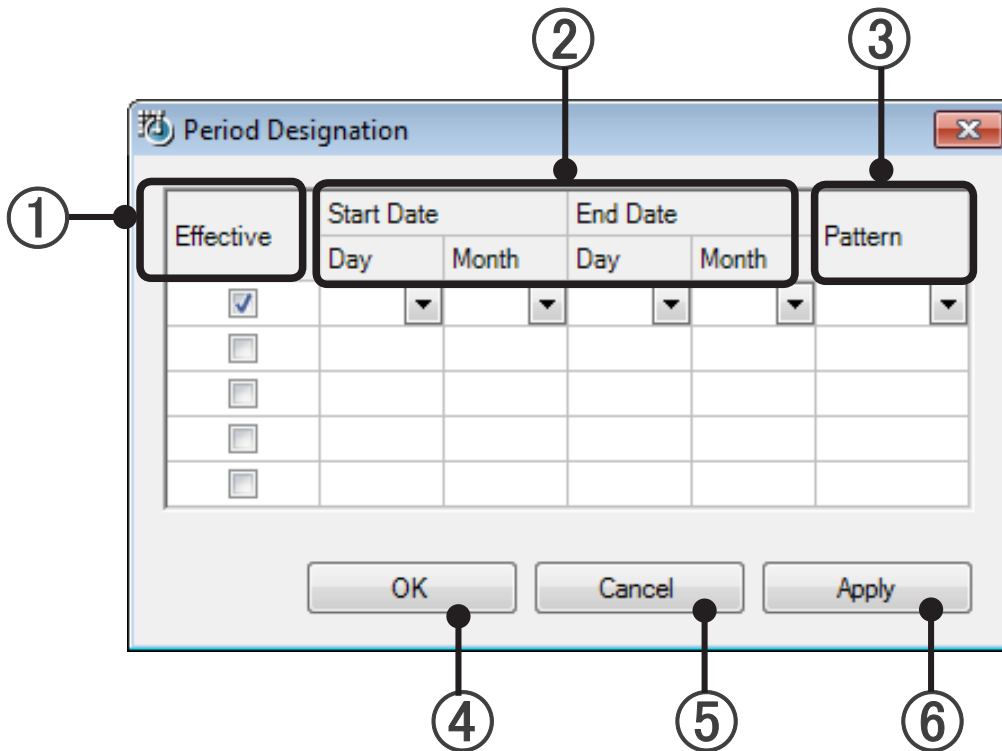

① Effective	By checking, the period and pattern will be enabled, and press the OK or Apply button to reflect these in the calendar. If the check is removed, pressing the OK or Apply button will delete it.
② Period	Set the Start Date and End Date.
③ Pattern	Set the patter for the relevant period.
④ OK button	The configured details will be reflected in the calendar. Close the screen.
⑤ Cancel button	Discard data during editing, and close the screen.
⑥ Apply button	The configured details will be reflected in the calendar. Do not close the screen.

19-6 Exceptional day (holiday, etc.) setting

Special operation schedule days (exceptional days) can be set. (Max 50 lines)

To display this screen, click the [Edit] button in the Exceptional Day area on the Schedule Setting screen.

19-6-1 Exceptional Day Setting screen

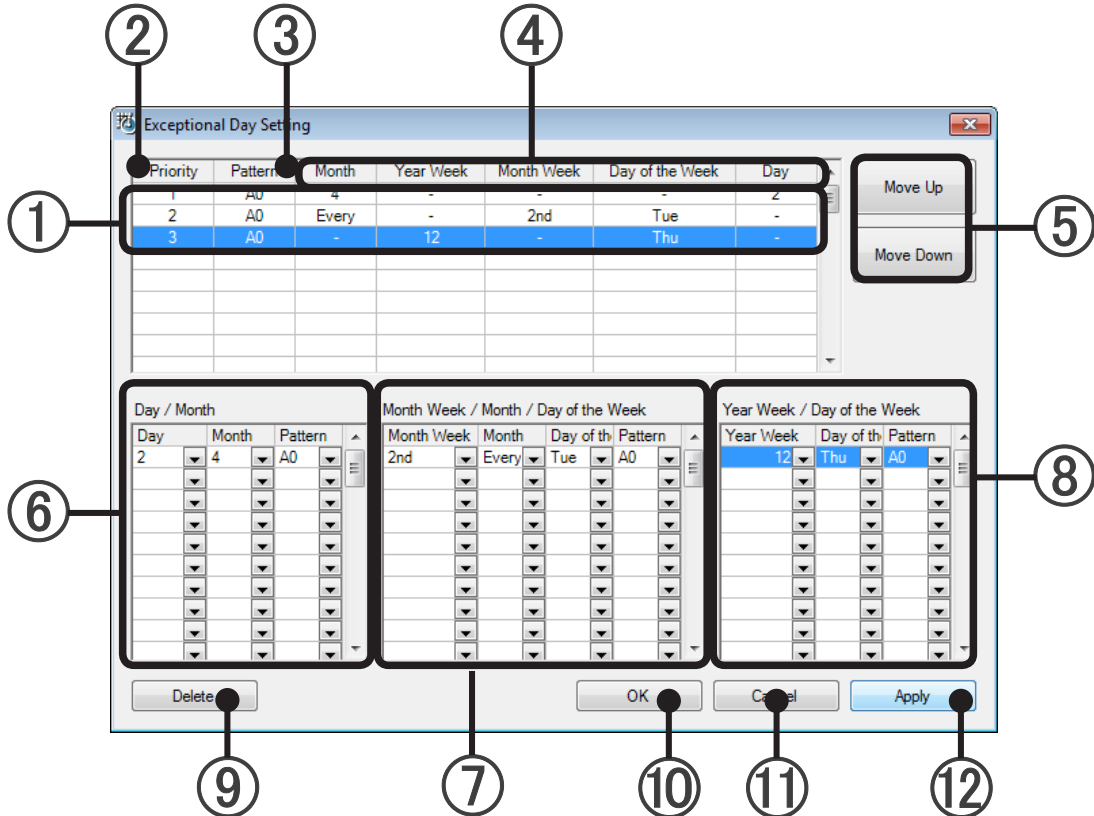

* Operation is impossible if even one operation pattern was not created. Create an operation pattern first.
→ See par. 19-3 Operation pattern creation

① Exceptional day list	Exceptional day setting contents.
② Priority	When set days overlap, setting is applied by giving the day with the lowest number priority.
③ Pattern	Shows the operation pattern to be applied.
④ Exceptional day specification	Displays the exceptional day specification method. Month/week number (year)/week number (month)/day of week/day
⑤ Move Up/Move Down buttons	Change the priority order.
⑥ Day/Month area	Specifies the exceptional day and assigns a pattern by month/day.
⑦ Month Week/Month/Day specification area	Specifies the exceptional day and assigns a pattern by month/day of week of which week.
⑧ Week number/day of week specification area	Specifies the exceptional day and assigns a pattern by week number (year)/day of week. Displayed only when a calendar beginning from Monday is set.
⑨ Delete button	Deletes the exceptional day selected with ①. Cannot be canceled using [Cancel] button.

⑩ OK button	Reflects the set contents and closes the setting screen.
⑪ Cancel button	Closes the setting screen without reflecting the contents set with ⑤, ⑥, ⑦, and ⑧.
⑫ Apply button	Setting screen remains displayed and reflects the contents set with ⑤, ⑥, ⑦, and ⑧.

19-6-2 Overview of exceptional day creation

- ① Click the [Edit] button in the Exceptional Day area of the Schedule Setting screen.

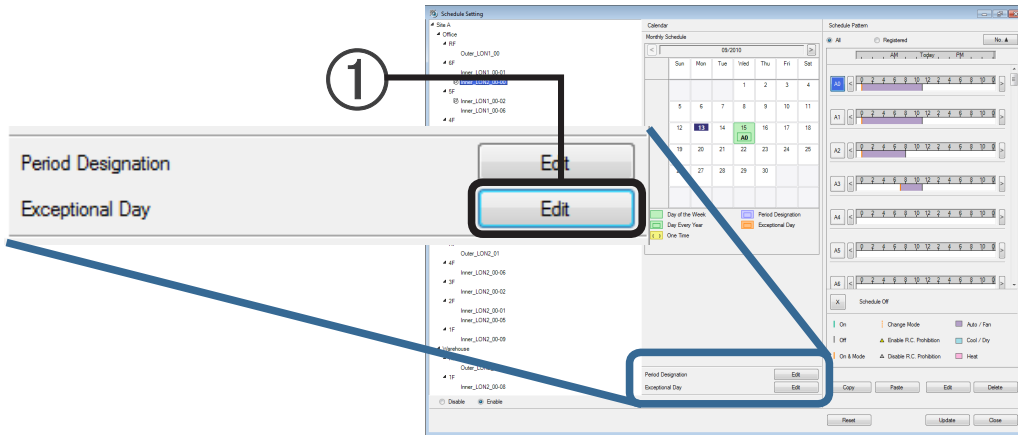

- ② The Exceptional Day Setting screen is displayed. Set the exceptional day and pattern. Confirm the pattern to be set in advance.

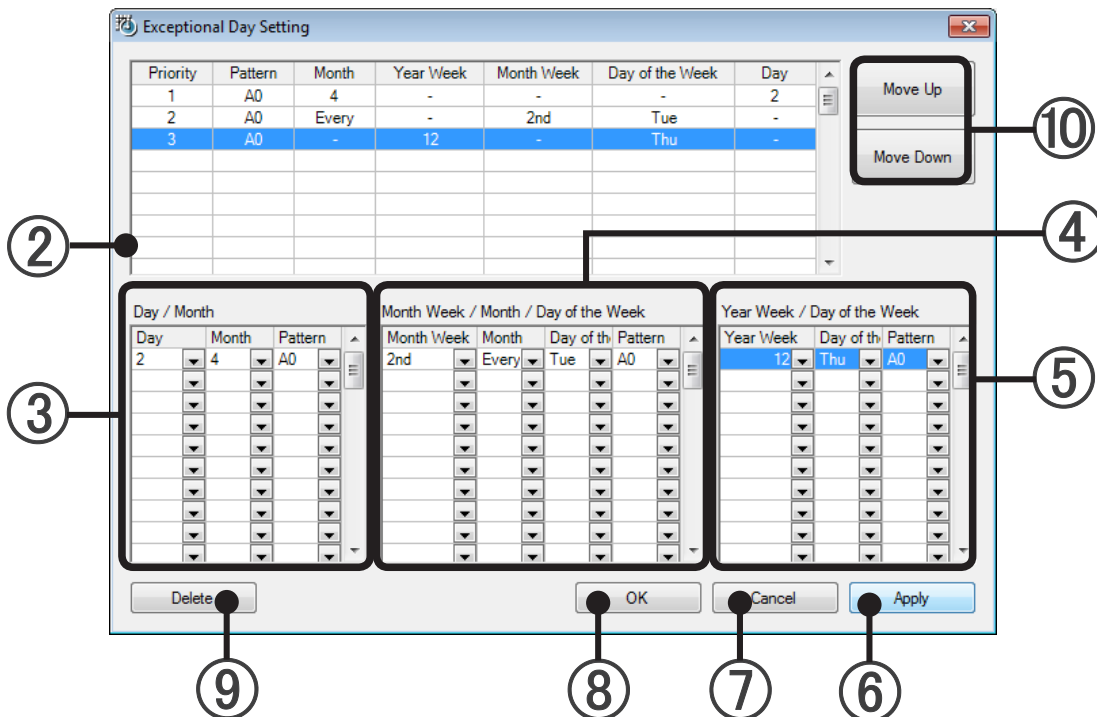

There are the following methods of setting the exceptional day and pattern. Select the appropriate method.

- ③ Set a specific day. Select the month/day from the Day/Month specification area and set the pattern.
Day selection contents: Every, 1 to 31
Month selection contents: Every, 1,2,3,4,5,6,7,8,9,10,11,12
- ④ Set from month week/month/day of week. Combine from the "Month Week/Month/Day" specification area and set the pattern.
Month Week selection contents: 1st, 2nd, 3rd, 4th, 5th
Month selection contents: Every, 1,2,3,4,5,6,7,8,9,10,11,12
Day selection contents: Every, Sun, Mon, Tue, Wed, Thu, Fri, Sat
- ⑤ Set from the week number and day of week. Combine from the Year Week/Day specification area and set the pattern. This is displayed only when a calendar starting from Monday is set
Year Week selection contents: 1 to 53 (Select the week number from the beginning of the year.)
Day selection contents: Every, Sun, Mon, Tue, Wed, Thu, Fri, Sat
- ⑥ At the end of setting, click the [Apply] button.
The contents set with ③, ④, ⑤ and ⑩ are reflected in the exceptional day list.
- ⑦ To cancel a setting, click the [Cancel] button.
The Exceptional Day Setting screen is closed without reflecting the contents in the settings made with ③, ④, ⑤ and ⑩.
- ⑧ When setting is complete, click the [OK] button.
The contents in the settings made with ③, ④, ⑤ and ⑩ are also reflected in the exceptional day list and the Exceptional Day Setting screen is closed
- ⑨ To delete an exceptional day setting displayed in the exceptional day list, select the exceptional day to be deleted and click the [Delete] button. That exceptional day is deleted from the list.

Changing the exceptional day list priority order

- ⑩ Select the exceptional day whose priority is to be changed and change it to the desired priority by clicking the [Move Up] or [Move Down] button.
"Priority order" is the order of the exceptional days applied by giving priority to the exceptional day with the lowest number when the days set during multiple setting overlap.
If the [OK] button or [Apply] button is not clicked after the order was changed, the change will not be reflected.

20. Error Monitoring

20-1 Overview of error notification

When an error occurs in the system, the following are displayed:

1. [Status: Error] blinks red at the status display at the top right-hand corner of the main screen.
2. An Error Notification screen is displayed.

This screen can also be opened by clicking main screen menu → “Error” → “Error Notification”.

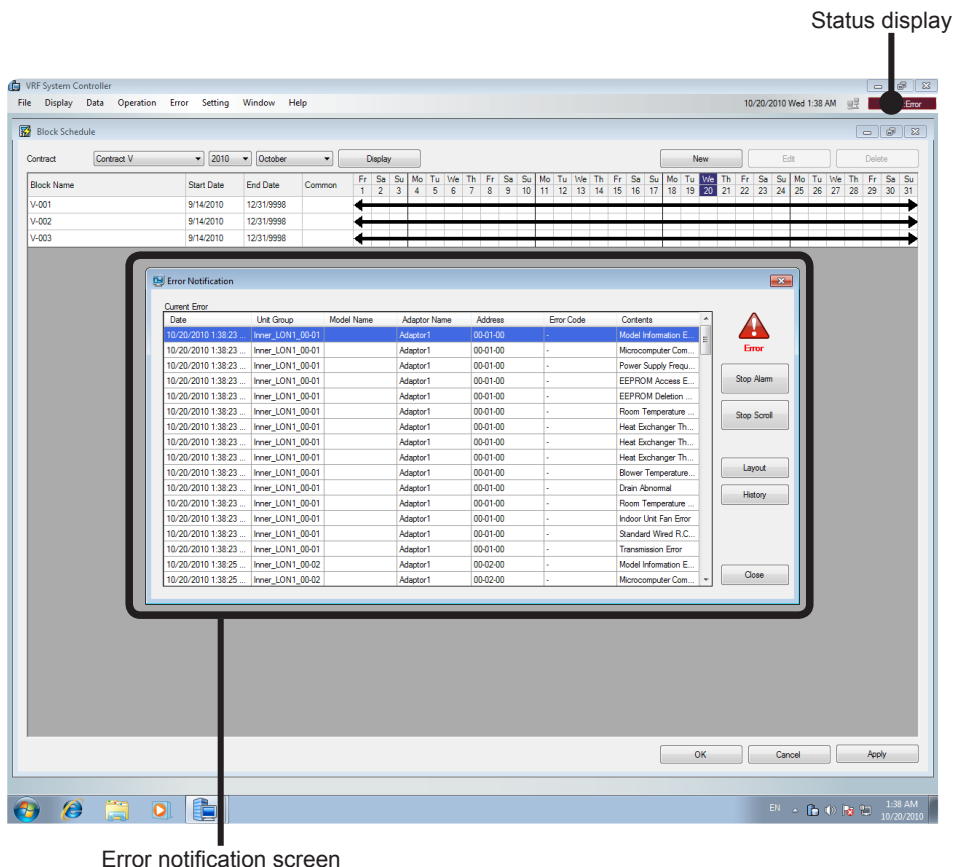

The unit that generated the error, installation site, and history can be ascertained from the Error Notification screen.

20-2 Status display

The following states are displayed at the Status display at the top right-hand corner of the main screen:

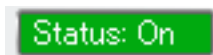

Operation display

If even one unit is operating, [Status: On] lights.

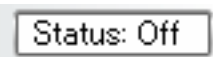

Stop display

If all the connected units are stopped, [Status: Off] lights.



Error display

[Status: Error] blinks when an error occurs.

If this display is double clicked even when the Error Notification screen is not displayed, the Error Notification screen will be displayed again.

20-3 Error Notification screen

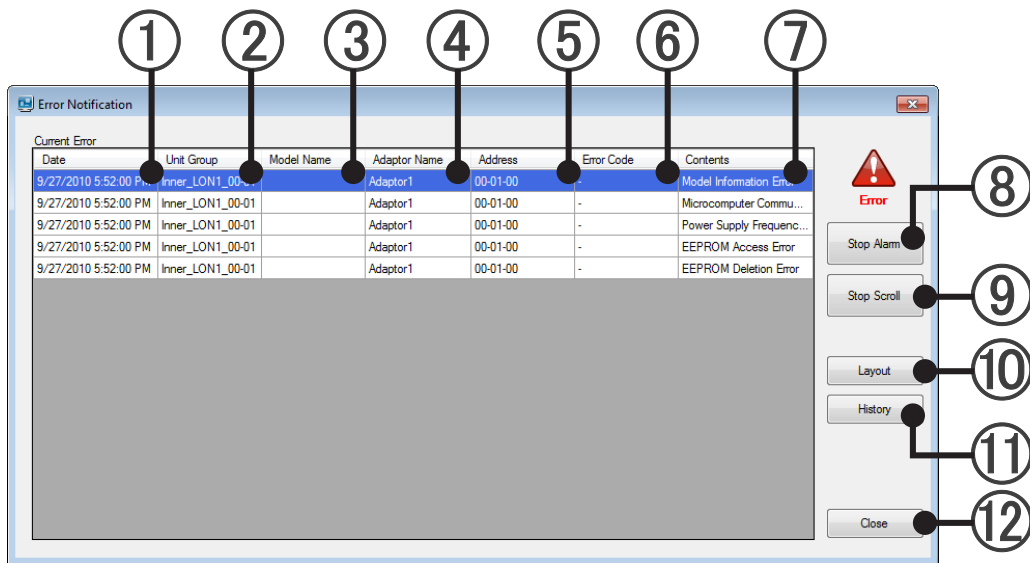

① Date	Generation date
② Unit Group	R/C group name
③ Model Name	Model name* *The letter "." as the last letter of the Model Name signifies that the Model Name for the corresponding unit was written after shipment. The letter "." is not part of the Model Name.
④ Adaptor Name	U10 USB Network Interface name
⑤ Address	"Refrigerant system address"- "Unit address"- "R/C address"
⑥ Error Code	Error code → See par. 25-2 Error code table
⑦ Contents	Error contents
⑧ Stop Alarm button	Stops the alarm sound. However, if the error occurs again, the alarm sound will be generated.
⑨ Stop Scroll button	When the R/C group at which the error occurred exceeds the display area of the Error Notification screen, it is displayed by scrolling the display area. This button stops that scrolling. This button is used when stopping scrolling and checking the error contents. However, while scrolling is stopped, the contents are not updated even if a new error occurs or an error is restored. To resume scrolling, click this button again.
⑩ Layout button	The location of the unit generating the error can be identified. When a unit is selected and this button is clicked, a Unit Layout screen showing the location of that unit is displayed.
⑪ History button	Displays the Error history of the unit at which the error occurred. When the unit is selected and this button is clicked, an Error History screen showing the history of that unit is displayed.
⑫ Close button	Closes the Error Notification screen.

20-4 Identifying the location of unit that generated the error

Identifies the location of the unit that generated the error.

- 1 Select the unit that generated the error.

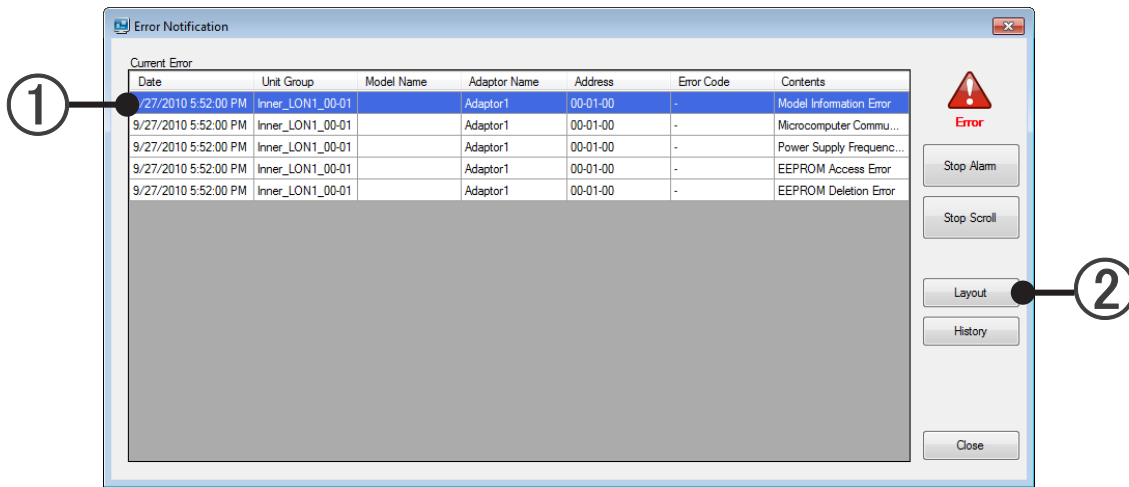

- 2 Click the [Layout] button.
- 3 A Unit Layout screen opens.

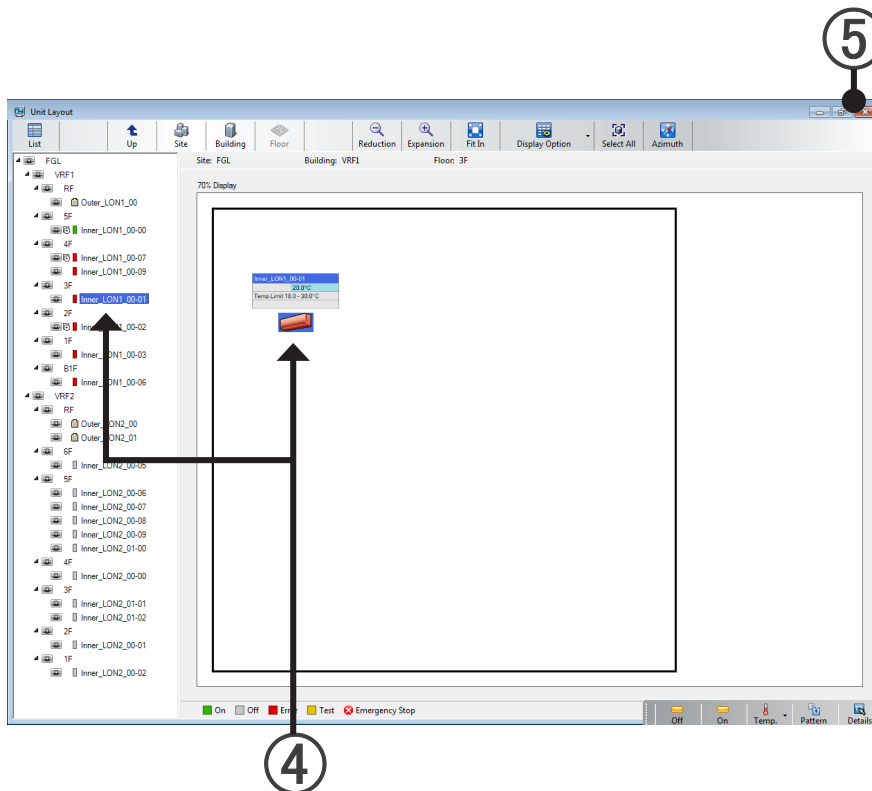

- 4 The unit that generated the error is displayed by Error status.
- 5 To close the Unit Layout screen, click the [X] button at the top right-hand corner of the screen.

20-5 Unit error history

20-5-1 Error History screen display method

Views the history of the unit generating the error.

- 1 Select the unit that generated the error.

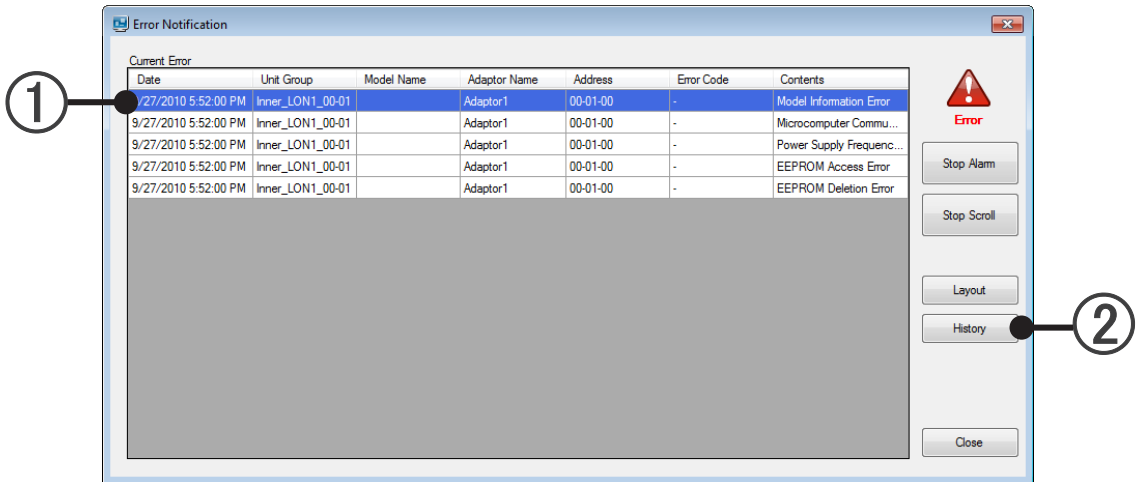

- 2 Click the [History] button.
- 3 An Error History screen opens.

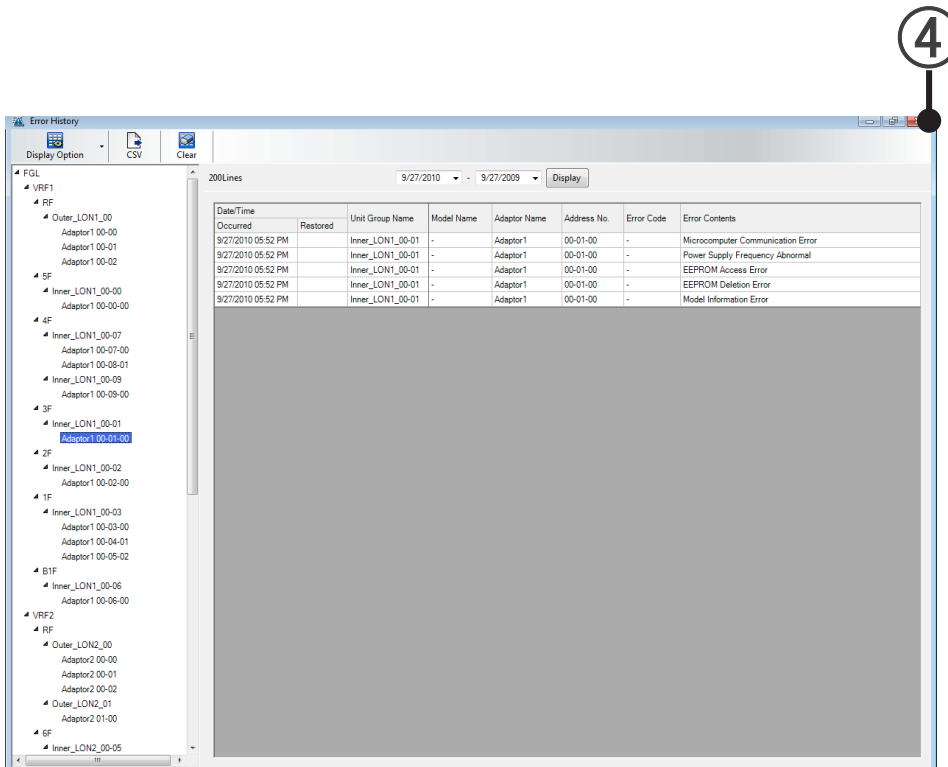

- 4 To close the Error History screen, click the [X] button at the top right-hand corner of the screen.

20-5-2 Error History screen

Unit and System Controller error generation history is displayed. The history save period is 1 year. This screen can also be opened by selecting main screen menu → “Error” → “Error History”.

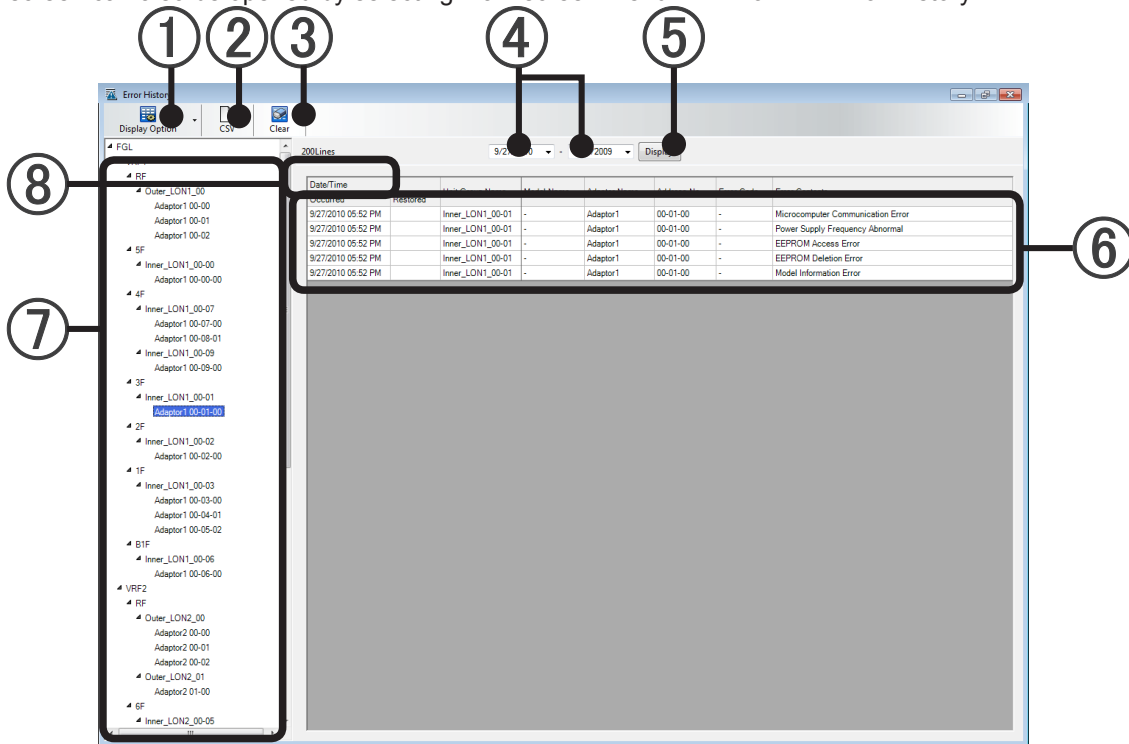

① Display Option button	Specifies the number of lines on 1 page of the history display. 20, 50, 100, 150, 200 lines (Default: Remote 20 lines, Local 200 lines)
② CSV button	Writes the history display at ⑥ as CSV format data.
③ Clear button	Delete abnormality history for all units. This will not be displayed if operating remotely.
④ History display period specification	Specifies the period of time whose error history is to be displayed.
⑤ History display button	Displays the history for the period specified by ④ of the unit specified by ⑦.

⑥ History display contents	
Date/Time Occurred	Generation date and time
Date/Time Restored	Restoration date and time
Unit Group Name	R/C group name or outdoor unit group name. “-” displayed for System Controller Error.
Model Name	Model name* *The letter “:” as the last letter of the Model Name signifies that the Model Name for the corresponding unit was written after shipment. The letter “:” is not part of the Model Name. The S/V series will have “-” displayed.
Adaptor Name	U10 USB Network Interface name
Address No.	“Refrigerant system address”-“Unit address”-“R/C address”
Error Code	Error code → See par. 25-2 Error code table
Error Contents	Error contents

⑦ Unit selection tree	Selects the unit whose history is to be displayed. When Other Unit is selected, the error history for unit other than the indoor unit and the outdoor unit are displayed.
⑧ Number of lines of history display	Displays the number of lines specified by ①.

20-5-3 History display method

View errors generated in the past

- ① Select the unit whose history is to be displayed.

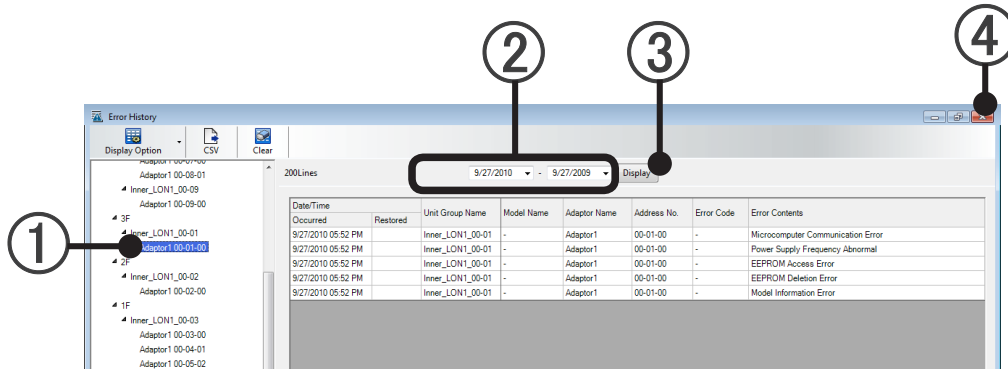

- ② Specify the period of time whose error history is to be displayed.
- ③ When the [Display] button is clicked, the history is displayed
Not displayed if there is no error history.

When connected remotely, a data acquisition progress bar is displayed.

When the [Stop] button is clicked when the data acquisition progress bar display appears, data acquisition stops and only the acquired history is displayed

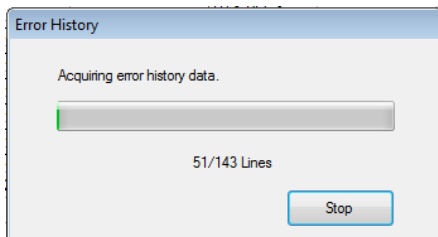

Data acquisition progress bar

- ④ To close the Error History screen, click the [X] button at the top right-hand corner of the screen.

20-5-4 Writing of history

The error generation history can be written to a CSV format file

The CSV format file can be browsed and edited with Microsoft Excel.

- ① Display the error history of the unit to be written in accordance with par. 20-5-3 History display method.
- ② Click the [CSV] button.

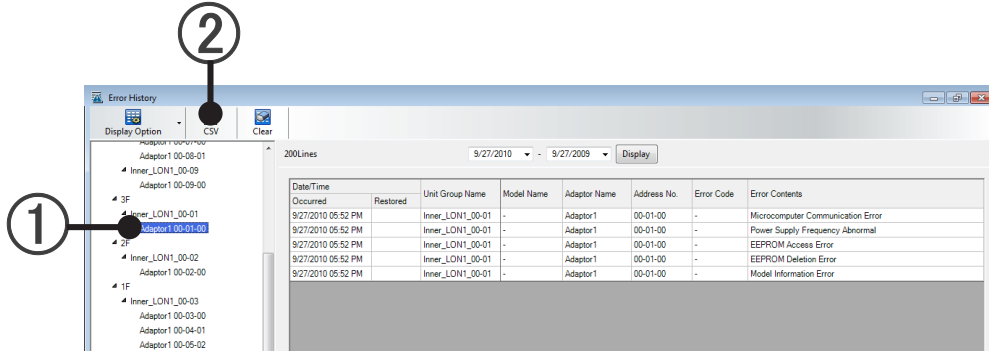

- ③ A file save dialog box opens. Select the write destination folder and enter the filename and click the [OK] button.
The error history is written in CSV format.

20-5-5 Sorting history display

The error history can be sorted.

History sorting

- ① The error generation history can be sorted by clicking on the title of the item which is made the sort key.
Ascending/descending can be switched by repeated clicking.

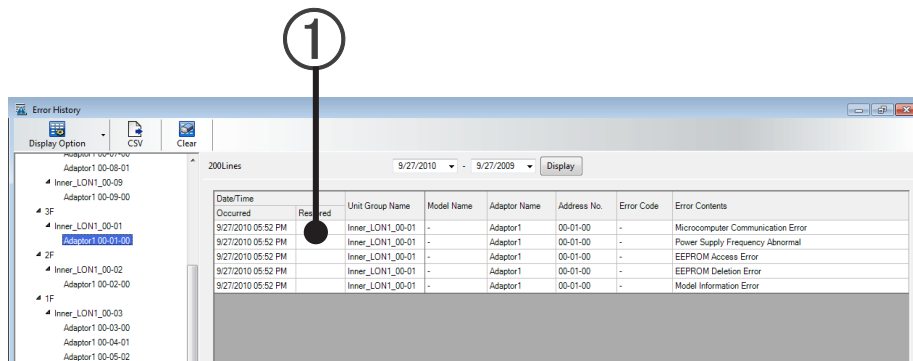

21. Operation Management

Unit management data and the history of operation control data from the system controller can be displayed. The history save period is 1 year.

21-1 Operation history

21-1-1 Operation History screen

To display this screen, click main screen menu → “Data” → “Operation History”.

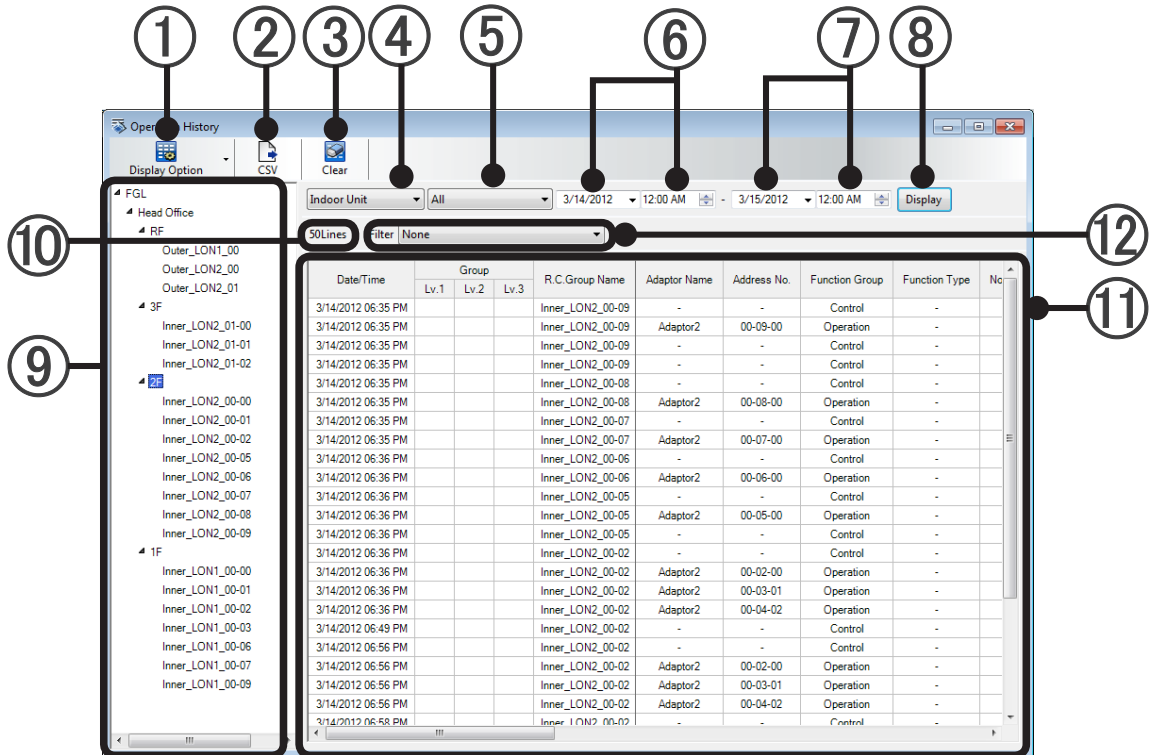

① Display Option button	Specifies the number of lines on one page of the history display. 20, 50, 100, 150, 200 lines (Default: remote 20 lines, local 200 lines)
② CSV button	Writes the history in CSV format.
③ Clear button	Clears the operation history of all the units directly connected from the server. Not displayed for remote operation.
④ Indoor unit/outdoor unit selection	Select indoor unit or outdoor unit.
⑤ Function Group Selection	Displays the selected Function Group.
⑥ History period start specification	Specifies the date and time history display is to start.
⑦ History period end specification	Specifies the date and time history display is to end.
⑧ History display button	Displays the history of the R/C group selected by ⑧ for the period specified by ⑤ and ⑥.
⑨ Unit selection tree	Selects the R/C group whose history is to be displayed.
⑩ Number of lines of history display	Displays the number of lines specified by ①.

⑪ History display contents	Indoor unit
Date/Time	Operation date and time
Group Lv.1	Group level 1 group name
Group Lv.2	Group level 2 group name
Group Lv.3	Group level 3 group name
R.C. Group Name	R/C group name
Adaptor Name	U10 USB Network Interface name
Address No.	“Refrigerant system address” - “Unit address” - “R/C address”
Function Group	Operation / Control / Schedule / Energy Save Control
Function Type *1	Thermostat Off / Temperature Shift
Normal/Error	Normal/error
Operation Status	Operation status On/Off/Test
Operation Mode	Operation mode
Set Temp	Set temperature
R.C.Prohibition	R/C prohibition All, On/Off, On, Mode, Temp, Filter
Fan Speed	Fan speed Auto, Low, Med, High
Anti Freeze	Anti Freeze On,Off
Economy	Economy operation On, Off
Air Flow Direction VT	Vertical Air Flow Direction status
Air Flow Direction HZ	Horizontal Air Flow Direction status
Temp. Limit (°C/°F)	Temperature upper/lower limits setting
Status	Temperature upper/lower limits setting status
Cool/Dry	Temperature upper/lower limits setting at Cool/Dry
Heat	Temperature upper/lower limits setting at Heat
Auto	Temperature upper/lower limits setting at Auto
Forced Thermostat Control *1	Forced Thermostat Off or Not
Information	Special operation status Emergency Stop / Pump Down / Maintenance Mode / Defrost / Oil Recovery / Mode Mismatch
User Name	Operation user name

*1. These columns will be displayed only when the energy saving option (UTY-PEGX) is used.

⑪ History display contents	Outdoor unit
Date/Time	Operation date and time
Group Lv.1	Group level 1 group name
Group Lv.2	Group level 2 group name
Group Lv.3	Group level 3 group name
Unit Group Name	Outdoor unit group name
Adaptor Name	U10 USB Network Interface name
Address No.	“Refrigerant system address” - “Unit address”
Function Group	Operation / Low Noise Operation / Energy Save Control
Function Type *1	Forced Off / Capacity Save Control
Normal/Error	Normal/error
Low Noise Operation Priority	Low Noise / Performance
Low Noise Operation Level	Off / Level 1 / Level 2
Capacity Control *1	Operation Rate 50~100(%)
Information	Special operation status Emergency Stop / Maintenance Mode / De-frost / Oil Recovery
User Name	Operation user name

*1. These columns will be displayed only when the energy saving option (UTY-PEGX) is used.

⑫ Selection of status change extraction conditions	<p>Only records with value of specified lines changed are displayed.</p> <p>*When there is displayed data in the list after the ⑧“Display” button is pressed, the target items are displayed in the combo box of status change extraction.</p> <p>*As for extraction, the data of "Operation" at ⑤"Function Group" are targeted.</p> <p>*When multiple RCG are displayed, they are compared and extracted in each unit (adapter + unit address).</p>
---	--

21-1-2 History display method

- ① Select the unit whose history is to be displayed

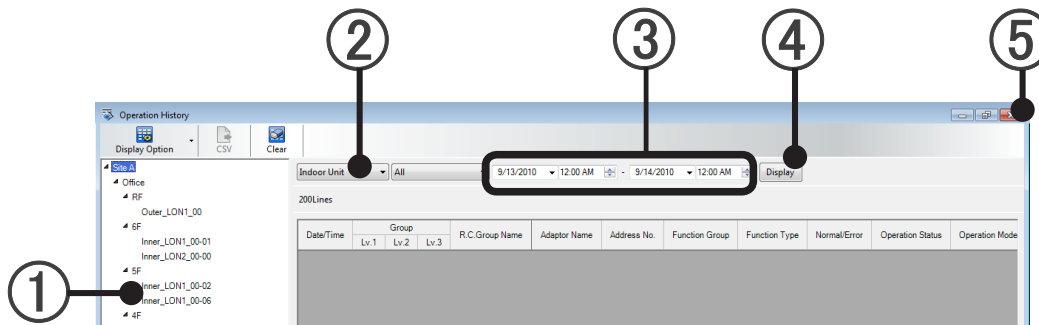

- ② Select indoor unit or outdoor unit.
- ③ Specify the period of time whose history is to be displayed.
- ④ When the [Display] button is clicked, the history is displayed.

For remote connection, a data acquisition progress bar is displayed.

When the [Stop] button is clicked when the data acquisition bar display appears, data acquisition is stopped and only the acquired history is displayed.

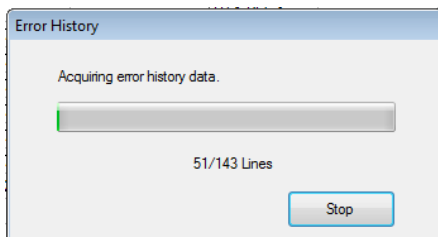

Data acquisition progress bar

- ⑤ To close the Operation History screen, click the [X] button at the top right-hand corner of the screen.

21-1-3 Writing of history

The operation history can be written to a CSV format file.

The CSV format file can be browsed and edited with Microsoft Excel.

- ① Display the operation history of the unit to be written in accordance with par. 21-1-2 History display method.
- ② Click the [CSV] button.

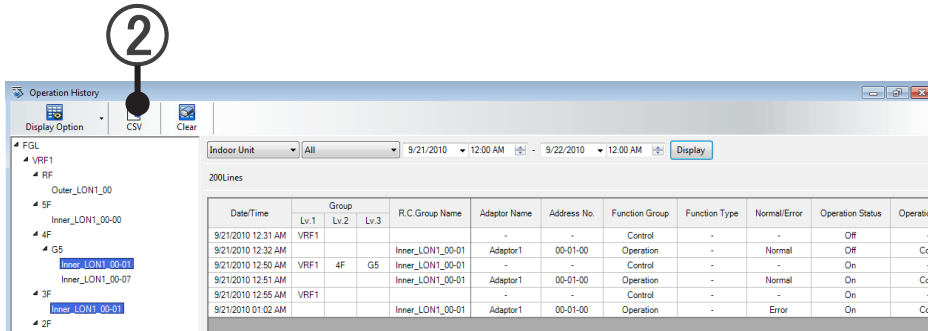

- ③ A file save dialog box is displayed. Select the write destination folder and enter the filename and click the [OK] button.
The operation history is written in CSV format.

21-1-4 History display sorting

The operation history display can be sorted.

History sorting

- ① The operation history can be sorted by clicking the title of the item which is made the sort key. Ascending/descending can be toggled by repeated clicking.

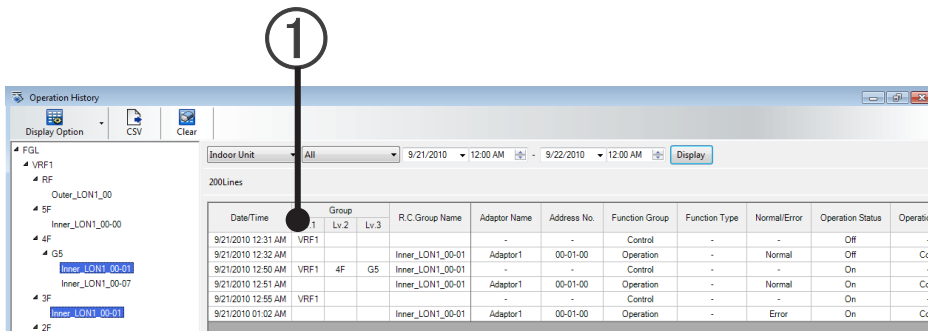

22. Electricity Charge Apportionment

22-1 Electricity charge apportionment main screen

The billed amount from the electric company is input and apportionment calculation is performed. Here, apportionment calculation is performed after electric power consumption data acquisition. For a description of electric power consumption data acquisition and electricity charge apportionment calculation related settings, see par. 9 Electricity Charge Apportionment Setting.

To display this screen,
click main screen menu → “Data” → “Electricity Charge Apportionment”.

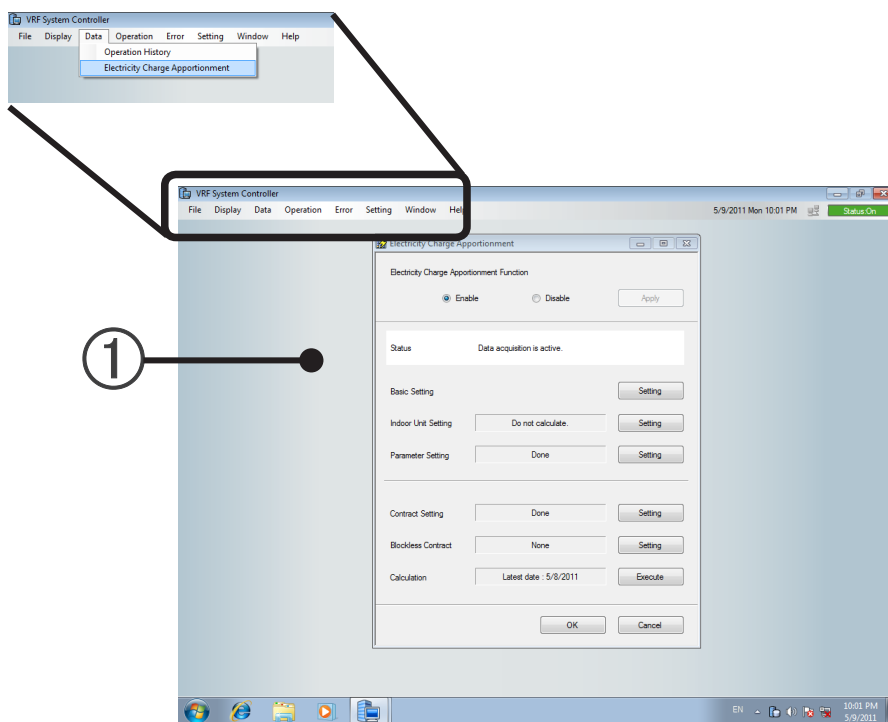

① Electricity Charge Apportionment main screen.

22-1-1 Electricity Charge Apportionment main screen

Description of screen

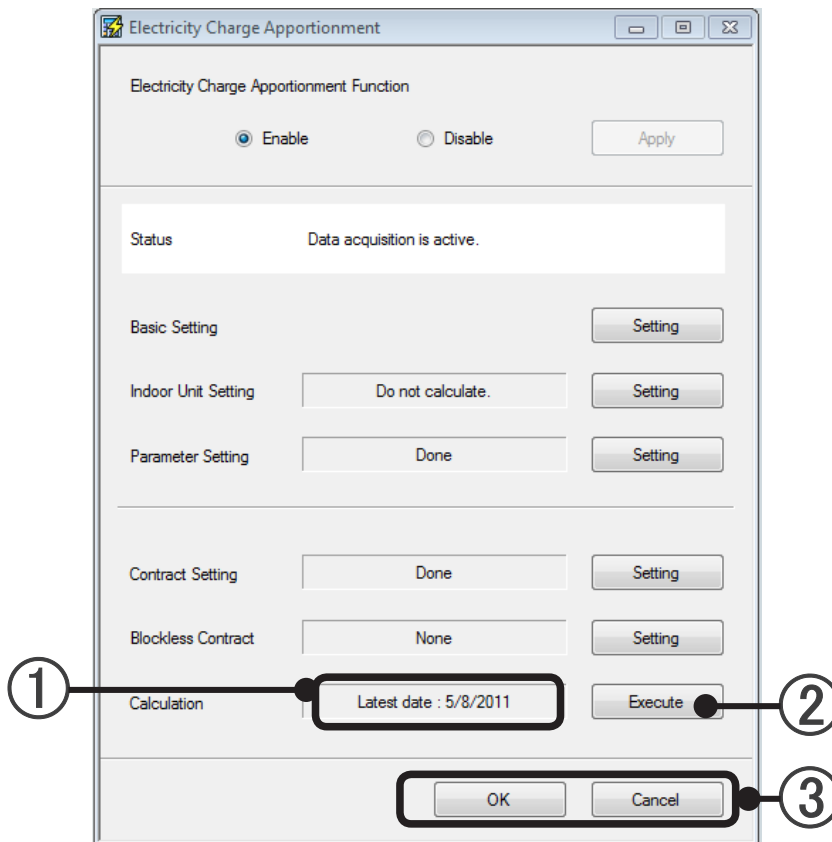

- ① The latest date which can be calculated is displayed.
- ② Executes calculation
When clicked, the Apportionment Calculation screen (22-2-1) opens.
- ③ Complete Electricity charge apportionment calculation.
[OK]: Save edited contents and end.
[Cancel]: End without saving edited contents
You cannot calculate the start day of data collection.

22-2 Apportionment calculation execution

To display this screen, click the [Execute] button of the Calculation item on the Electricity Charge Apportionment main screen.

22-2-1 Apportionment Calculation screen

Description of screen

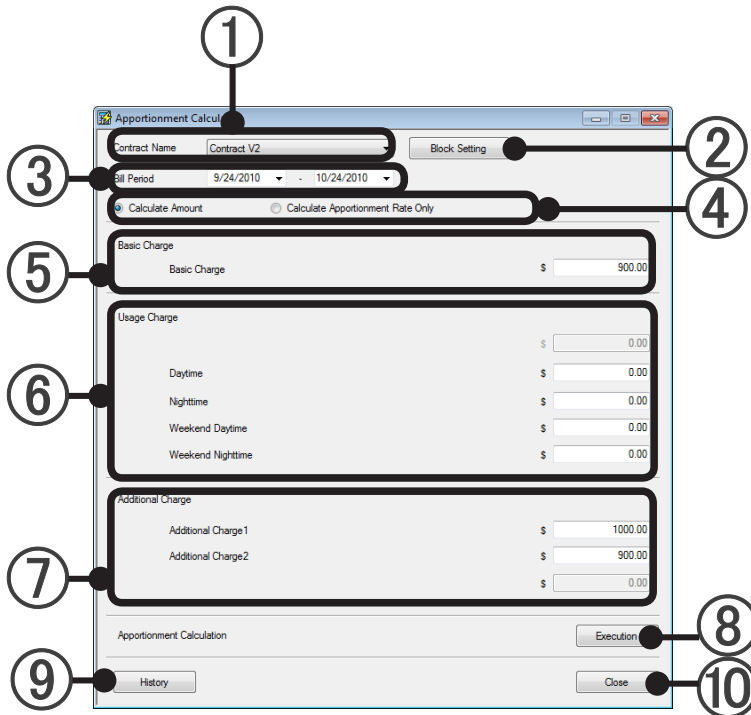

- ① Selects the calculation target contract.
- ② [Block Setting] button: When you want to check or change the block setting, click this button to open the [Block Schedule Setting] (9-7-1) screen. Close the screen after checking or changing the block setting.
- ③ Sets the billing target period.
Text can be input.
When the drop-down button at the right-hand side is clicked, a date selection calendar is displayed.
Select the day.
The range of the period over which there is electric power apportionment collection data in the contract period can be selected.
- ④ Select "Calculate Amount" or "Calculate Apportionment Rate Only".
Calculate Amount: Calculates the apportionment rate and the actual amount billed to each block based on that apportionment rate and the amount.
Calculate Apportionment Rate Only: Calculates the apportionment rate only of each block based on the amount of electricity used.
When "Calculate Apportionment Rate Only" is selected, ⑤, ⑥, and ⑦ cannot be input.
- ⑤ If there is a basic charge, input the amount.
Input is possible when basic charge setting is performed at 9-6-2 New contract creation and editing.
The name of the basic charge set at the par. 9-6-2 New contract creation and editing is displayed.

- ⑥ If there is a usage charge, input the amount respectively. (Within 11 digits each)
- Daytime ■ Nighttime ■ Weekend daytime ■ Weekend nighttime
- When nighttime charge setting is performed at the par. 9-6-2 New contract creation and editing, ■ Nighttime input is possible.
- When weekend charge setting is performed at the par. 9-6-2 New contract creation and editing, ■ Weekend daytime input is possible.
- When nighttime charge setting and weekend charge setting are performed at the par. 9-6-2 New contract creation and editing, ■ Weekend nighttime input is possible.
- When nighttime charge setting and weekend charge setting are not performed at the par. 9-6-2 New contract creation and editing, only the topmost item can be input.
- ⑦ If there is an additional charge, input the amount. (Within 11 digits each)
- Add1 ■ Add2 ■ Add3
- Input is possible when additional charge setting is performed at the par. 9-6-2 New contract creation and editing.
- ⑧ Perform apportionment calculation. When the [Execution] button is clicked, Confirmation screen appears. Click the [Yes] button. a calculating progress bar and [Cancel] button are displayed.
- When the progress bar reaches 100%, apportionment calculation is complete and the [Calculation result] screen (22-2-2) is opened.
- When the [Cancel] button is clicked, apportionment calculation is stopped and the display returns to the Apportionment Calculation screen.

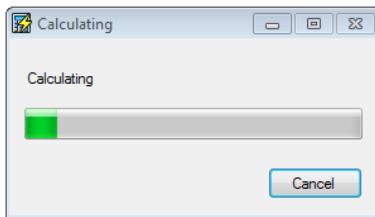

- ⑨ Displays the History Selection screen. (The calculation items input before the history can be input. See par. 22-2-3 Calculation history.)
- ⑩ Click to end and close the screen after apportionment calculation ends or the calculation result is printed.

Note

Apportionment calculation may take several tens of minutes or more depending on the number of units calculation and calculation objective period. Since no operations can be performed during this time, be amply careful when performing apportionment calculation.

22-2-2 Calculation result screen

Calculation Result screen (Amount calculation example)

This screen is displayed after the [Execution] button at the par. 22-2-1. Apportionment Calculation screen is clicked and the calculating progress bar reaches 100%.

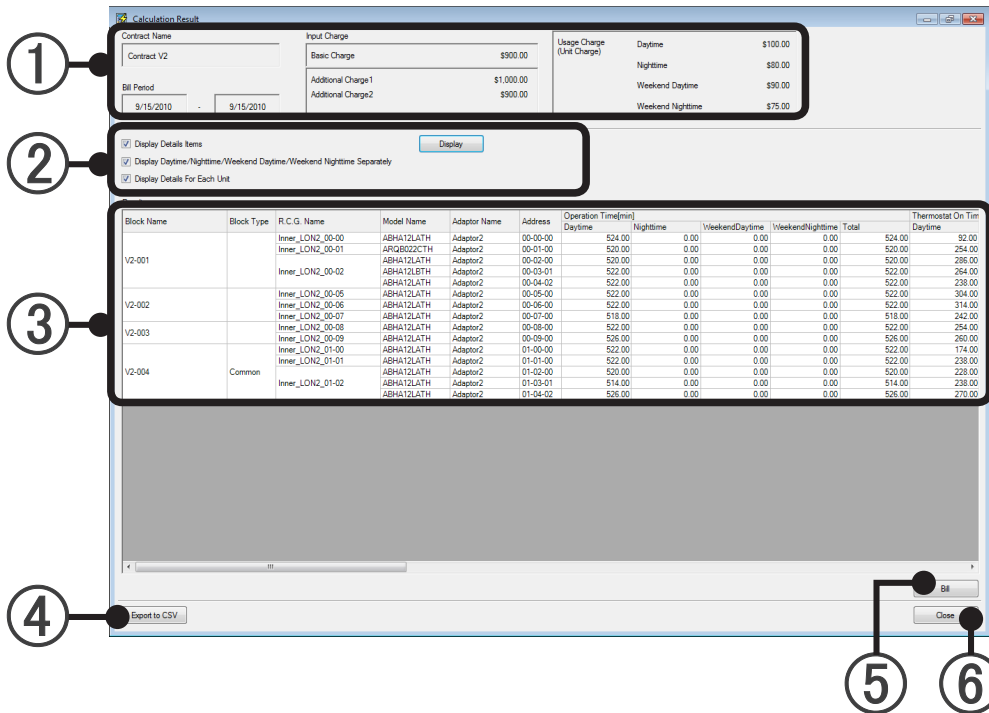

- ① Displays the contract name, bill period, and entered amount (amount from the electricity company) of the basic charge, additional charge, daytime charge, nighttime charge, weekend daytime charge, and weekend nighttime charge.
- ② Adds a details display to ③ Calculated charge. (Reflected when the [Display] button is clicked when the check box is ON.)
 - (a) Displays the detail items. (Operation Time/ Thermostat ON / Total Energy Used)
 - (b) Displays the daytime charge / nighttime charge / weekend daytime charge / weekend nighttime charge.
 - * Cannot be checked when both nighttime charge and weekend charge are not set
 - (c) Displays the details for each unit.
- ③ Displays the calculation result.
 - For "Calculate Amount" and "Calculate Apportionment Rate Only"

Block Name	Displayed without regard to the checking of (a),(b), and (c).				
Block Type (Common, Undefine)					
R.C.G. Name	Displayed on when (c) is checked.				
Model Name *					
*The letter "." as the last letter of the Model Name signifies that the Model Name for the corresponding unit was written after shipment. The letter "." is not part of the Model Name.					
Adaptor Name					
Address	Displayed on when (a) is checked.				
Operation Time				Day, Night, Weekend Day, Weekend Night, Total	Displayed on when (b) is checked.
Thermostat ON Time					
Total Energy Used					

- For “Calculate Amount”

Charge	Day, Night, Weekend Day, Weekend Night	Displayed on when (b) is checked.
Charged Amount		
Basic Charge		
Common Charge		
Additional Charge 1		
Additional Charge 2		
Additional Charge 3		
Sub Total Charge *1		Displayed only when tax calculation setting effective. → See par. 9-6-2 ⑦
Tax		
Total Charge		

When there is a fraction in the apportionment result, it may be displayed as Undefined Block charge.

*1. Amount with Tax subtracted from Total Charge

- For “Calculate Apportionment Rate Only”

Apportionment Rate	Day, Night, Weekend Day, Weekend Night
--------------------	--

- ④ Writes the data in CSV format
Write the contents displayed by ③ to a file.
To reflect the details display setting of ②, click the [Export to CSV] button after displaying to ③. A file save dialog box is displayed. Select the folder to be saved and input the filename and save.
- ⑤ Creates a bill. Advance to “Bill Creation” (22-3).
Cannot be pressed when “Calculate Apportionment Rate Only” is selected in 22-2-1 Apportionment Calculation screen.
- ⑥ Click to end and close the screen after checking the calculation result or printing a bill.

22-2-3 Calculation history

A history of past electricity charge apportionment calculations can be referenced and reflected at the Apportionment Calculation screen.

- 1 Click the [History] button of the Apportionment Calculation screen.

The History Selection screen opens.

Date/Time	Contract V	Charge	Bill Amount
9/16/2010 6:27 PM	9/14/2010-9/16/2010	Contract V	Charge
9/16/2010 3:14 AM	9/14/2010-9/14/2010	Contract V2	Charge
9/16/2010 3:13 AM	9/14/2010-9/14/2010	Contract V2	Charge
9/16/2010 3:03 AM	9/14/2010-9/14/2010	Contract V2	Charge
9/16/2010 3:01 AM	9/14/2010-9/14/2010	Contract V2	Charge
9/16/2010 3:01 AM	9/14/2010-9/14/2010	Contract V	Charge
9/16/2010 3:31 PM	9/14/2010-9/15/2010	Contract V	Charge
9/16/2010 3:10 PM	9/14/2010-9/15/2010	Contract V2	Charge

- 2 Calculate Period: Set the start and end of the period of time whose calculation history is to be displayed
- 3 When the [Display] button is pressed, the calculation history is displayed in the [calculation history list] of 4.

④ Calculation history list:

Displays apportionment calculation input contents for “Calculate Date” within the period specified by ② in a list.

When the [Calculate Date item] is clicked, the apportionment calculations can be sorted in old order or new order.

Calculate Date	Calculation date
Bill Period	Period of time that used the electricity charges to be billed
Contract Name	Calculated contract name
Calculation Method	Charge/Rate
Basic Charge	Total basic charge
Daytime Charge	Total daytime charge
Nighttime Charge	Total nighttime charge
Weekend Daytime Charge	Total weekend daytime charge
Weekend Nighttime Charge	Total weekend nighttime charge
Additional Charge 1	Total additional charge 1
Additional Charge 2	Total additional charge 2
Additional Charge 3	Total additional charge 3

* When nighttime charge setting and weekend charge setting is not performed, the billing amount of the power used is displayed at “Daytime Charge”.

⑤ [Delete] button:

If there is a calculation history you want to delete from the list of ④, select it and click the [Delete] button.

A confirmation screen is displayed. When [OK] is clicked, the data of the selected calculation history is deleted.

⑥ [Copy] button:

When you want to use input contents from the list of ④, select the calculation history and click the [Copy] button.

A confirmation screen is displayed. Click [OK].

The contents input at the Apportionment Calculation screen are destroyed.

The History Selection screen is closed and the data selected at the list of ④ is reflected at the Apportionment Calculation screen.

⑦ [Close] button:

Interrupts history referencing and closes the History Selection screen and returns to the Apportionment Calculation screen.

Note

The history does not reference past calculation results, but does reference the past data needed in calculation.

Data will be saved for 2 years.

22-3 Bill creation

Creates a bill for each block based on the amount of the apportionment calculation result.

22-3-1 Bill setting

To display this screen, click the [Bill] button on the “Calculation Result” screen.

Description of screen (Different from the initial screen in the state in which all the check boxes are ON)

The screenshot shows the 'Bill Setting' window with the following elements and callouts:

- 1**: Contract Name (Contract V2) and Bill Period (9/24/2010 - 10/24/2010).
- 2**: Table of Issue Bill and Block Name with checkboxes for V2-001, V2-002, and V2-003.
- 3**: Print Bill No. (201010-00001) and Print Issue Date (10/25/2010).
- 4**: Signature Of The Issuer field and Print Signature checkbox.
- 5**: Amount section with Print Bill Comment checkbox.
- 6**: Charge Details section with Print Detail Bill Amount, Print Detail, Do Not Print Detail, and Print Comment On Detail Bill Amount options.
- 7**: Operation Information section with Print Operation Time, Print Thermostat On Time, Do Not Print Detail, and Print Comments On Operation Time/Thermostat On Time options.
- 8**: Read Comment and Save Comment buttons.
- 9**: Bill Preview button.
- 10**: Close button.

- ① Check “Contract Name” and “Bill Period”.
- ② Select bill destination (Block) which is to output the bill. All select is possible by [Select All] button and all clear is possible by [Clear All] button.
- ③ Select whether or not the bill No. and bill issue date are to be printed.
(Bill No. is stored for each user in the VRF Controller database.)
When a check is entered, the number allocated by the VRF Controller database is input at “Bill No.” and the date the bill setting screen was opened is input at “Bill issue date”.
To change them, enter them at the “Bill No. (Within 15 characters of alphabet, numeric, symbol + 5 digits of numeric)” and “Bill issue date”.
- ④ Select whether “Signature of the Issuer” can be printed, enter a comment (500 characters or less), and select whether “Print Signature” can be printed.

- ⑤ Amount
Print Bill Comment check box:
Select whether or not a comment related to the bill is to be output.
To output a comment, enter the comment in the comment field. (Within 500 characters)
- ⑥ Charge Details
Print Detail Bill Amount check box:
Select whether or not basic charge (when set), usage charge, common charge, and additional charge 1 to 3 (when set) are to be output.
When Print Detail is selected, a summary of the nighttime charges and weekend charges is output.
Print Comment On Detail Bill Amount check box:
Select whether or not a comment related to the amounts summary is to be output.
To output a comment, enter the comment in the comment field. (Within 500 characters)
- ⑦ Operation Information
Print Operation Time check box:
Select whether or not Operation Time is to be output.
When Print Detail is selected, a summary of the Night Operation Time and weekend Operation Time is output. (Cannot be selected when both night time charge and weekend charge are not set.)
Print Thermostat On Time check box:
Select whether or not Thermostat On Time is to be output.
When Print Detail is selected, a summary of the Night Thermostat On Time and weekend Thermostat On Time is output. (Cannot be selected when both nighttime charge and weekend charge are not set.)
Print Comment On Operation Time/Thermostat On Time check box:
Select whether or not a comment related to Operation Time/Thermostat On Time is to be output.
To output a comment, enter the comment in the comment field. (Within 500 characters)
- ⑧ Saves and reads the bill output setting contents.
[Save Comment] button: Saves the setting contents and comments of ③ to ⑦ to a file.(.xml format)
[Read Comment] button: Reads the setting contents and comments of ③ to ⑦ from a file. (.xml format)
* Only the state of the checkbox is saved and read at ③.
- ⑨ Opens the Bill Preview screen.
(Prints at the preview screen and writes in .rpt format.)
Advance to par. 24-3-2 Bill printing preview.
- ⑩ Click to end bill creation after bill printing. The Bill Setting screen closes.

22-3-2 Bill printing preview

Displays a print preview of the bill.

Check the contents, and if there is no problem, print the bill.

Description of Bill Printing Screen

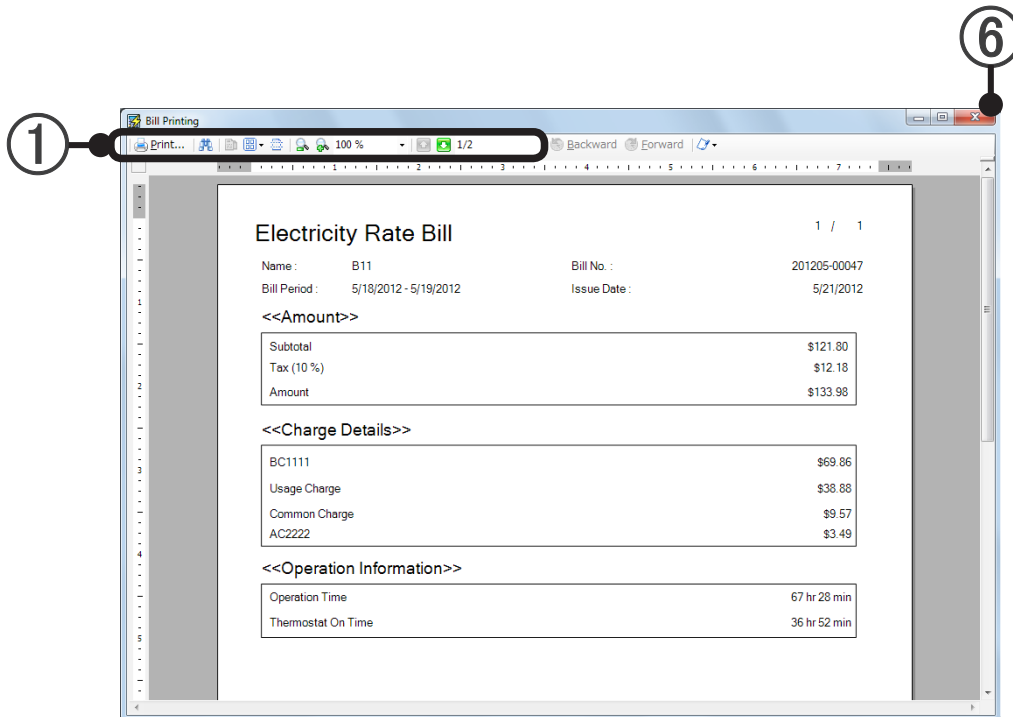

① Description of tools

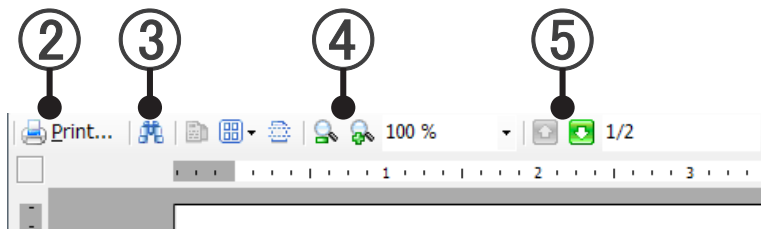

- ② Bill print
- ③ Text search in document
- ④ Preview display size specifications. (Zoom)
- ⑤ Bill page feed
- ⑥ After bill printing or the end of data write, close the Bill Printing Screen.

Note

- To end bill creation, after closing the Bill Printing Screen, click the [Close] button ⑩ of the “Bill Setting” screen (22-3-1).
- End apportionment calculation in order of “Calculation Result” screen (22-2-2), “Apportionment Calculation” screen (22-2-1), and “Electricity Charge Apportionment” main screen (22-1-1).

23. Low Noise Operation

You can group the outdoor-unit low noise operation mode schedule by days of the week, and then operate the unit.

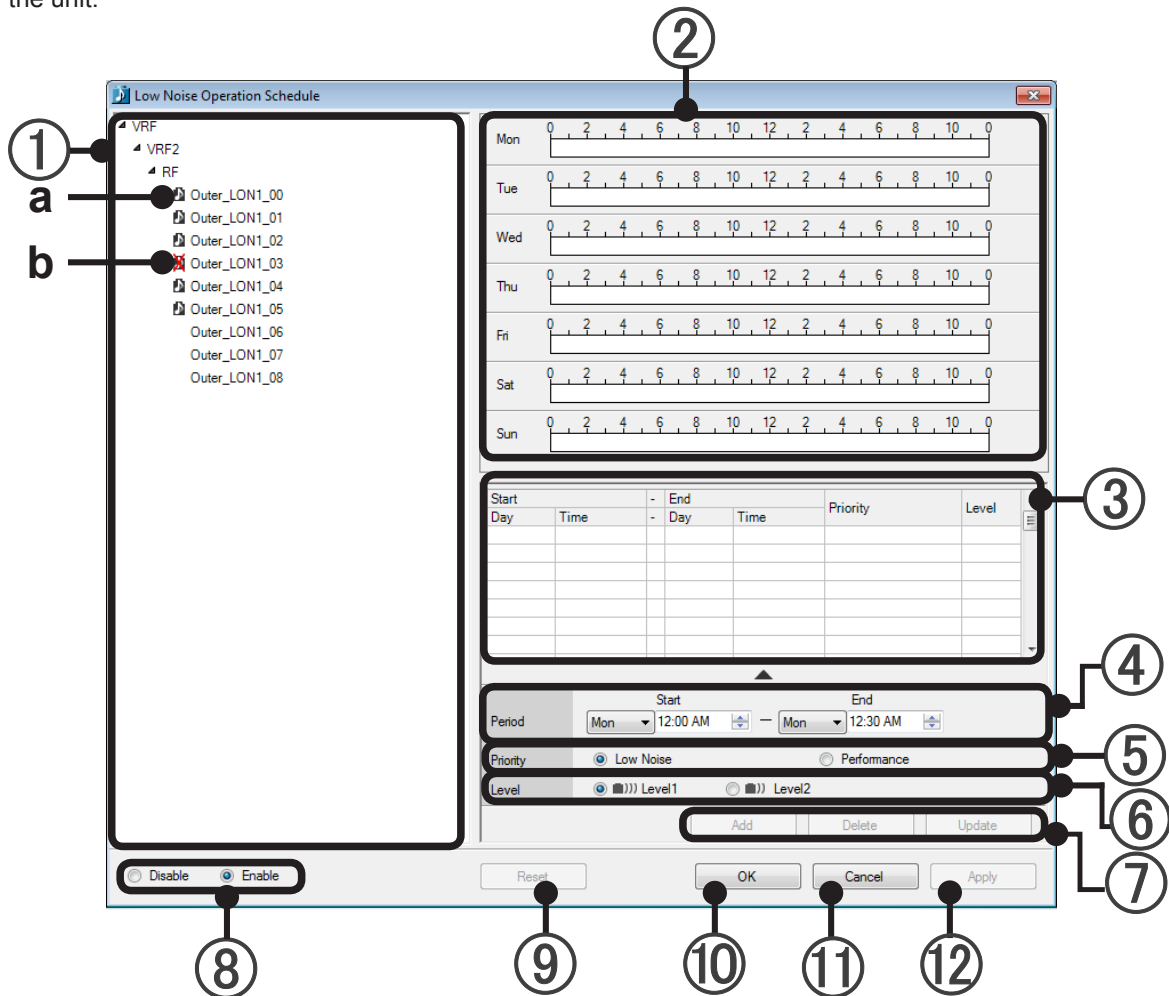

- ① Selection Tree
Display with the outdoor unit (including groups) taken out from the tree created on the group setting screen. (Outdoor units with low noise function disabled will not be displayed.)
Select the outdoor unit or group that you want to set low operating noise for, and create a low-operating noise schedule.
- ② Schedules
The details of the schedule list are displayed in a bar.
The bar display will change colors depending on the priority type, and the priority level will be displayed with a number.
- ③ Schedule List
The start and end days of the week and times, priority types and priority levels are displayed.
A maximum of 50 items can be registered.
- ④ Period
Set the day of the week and time range for running low noise operation.
You can configure the set time in units of 30 minutes.
- ⑤ Priority Types
Select quiet prioritization or power prioritization.

- ⑥ Level
You can select the priority level. There are 2 levels, 1 and 2, and the highest priority is level 1.
- ⑦ All Types of Button
- The “Add” button
The configured details will be displayed in the schedule bar and in a list.
 - The “Delete” button
If data from the list is selected and the details are deleted, the relevant schedule will disappear.
 - The “Update” button
The configured details will be reflected in the schedule bar and in a list.
- ⑧ Check schedule enable/disable.
- Enable: Enables the group or “Outdoor Unit” schedule selected by tree.
 - Disable: Disables the group or “Outdoor Unit” schedule selected by tree.
- ⑨ The “Reset” button
Discard data being changed, and return to the originally displayed details.
- ⑩ The “OK” button
Save changed details and close the screen.
- ⑪ The “Cancel” button
Discard data being changed, and close the screen.
- ⑫ The “Apply” button.
Enable the changed settings (having carried out Add, Update, or Delete), and do not close the screen.
- ⑬ Right-Click Menu
- Copy Schedule
Copy a selected schedule.
 - Paste
Enabled after copying has been carried out.
 - Delete
Delete the selected schedule.

Note

Press “OK” or “Apply” button after the schedule setting is changed (add/delete/update), the schedule will be controlled at current time at once.

Appendix

24. Product Specifications

25. Troubleshooting

26. FAQ

27. Definition Of Terms

24. Product Specifications

24-1 Operating condition

PERSONAL COMPUTER SPECIFICATIONS

Operating system	<ul style="list-style-type: none">• Microsoft® Windows® XP SP3 (32-bit) Professional (*1)• Microsoft® Windows® Vista® SP2 (32-bit) Home Premium, Business (*2)• Microsoft® Windows® 7 SP1 (32/64-bit) Home Premium, Professional (*2) [Supported languages] (*1) English only (*2) English, Chinese, French, German, Russian, Spanish, and Polish
CPU	Intel® Core™ i3 2GHz or higher
Memory	2GB or more (Windows® XP, Vista®, 7 32-bit) 4GB or more (Windows® 7 64-bit)
HDD	40GB or more of free space
Display	1024 x 768 or higher resolution
Interface	USB port is required for each of the followings for Server PC ; <ul style="list-style-type: none">• Wibu Key (Software protection key)• Echelon® U10 USB Network Interface (Required for each VRF Network) Ethernet port is required for remote connection using internet.
Accelerator	Requires the internal graphics accelerator be compatible with Microsoft® DirectX® 9.0
Software required	Adobe® Reader® 9.0 or later
Hardware required	DVD-ROM Drive

24-2 Specifications

Model		UTY-APGX	
Max number of connect-able units	USB compatible LON adaptor	4	
	Indoor unit	1600 (Max 400 units x 4 adaptors)	
	Outdoor unit	400 (Max100 units x 4 adaptors)	
	VRF Explorer	5	
Max number of sites		10	
Max number of buildings (/sites)		20	
Number of floors	(/sites)	200	
	(/building)	50	
Max number of groups		1600	
Max number of R/C groups		1600 (Max 400 groups x 4 adaptors)	
Compatible systems		S Series, V Series, V-II Series, J-II Series	
Compatible transmission adaptor		U10 USB Network Interface adaptor	
Compatible communication system with client server		TCP/IP, dial-up connection	
Air conditioning control function		Start/Stop	
		Master control setting	
		Fan speed setting	
		Room temp. setting	
		Room temp. set point limitation	
		Up/down air direction flap setting	
		Right/left air direction flap setting	
		Group setting	
		RC prohibition	
Display		Failure	
		Defrosting	
		Current time	
		Day of week	
		RC prohibition	
		Address display	
Timer	System schedule timer	On/Off per day	72
		On/Off per week	504
	Day off		
	Min. unit of timer setting (Minutes)		10
Control		Status monitoring system	
		Electricity charge calculation	
		Error history	
		Control via internet	
		E-mail notification for malfunction	

25. Troubleshooting

25-1 Troubleshooting

Trouble contents	
Cause	Countermeasures
Nothing is displayed on the Layout screen or List screen of the VRF Explorer monitor screen.	
Graphic chip of the PC used does not support "DirectX9.0C".	Change to a PC with graphic chip that supports DirectX, or install a DirectX compatible graphic board at an expansion slot.
When scanning, U10 USB Network Interface is not displayed as a selection choice.	
U10 USB Network Interface driver is not installed.	Install the OpenLDV supplied.
Power is not supplied.	If an USB hub is used or many USB units are connected, the power supply may be insufficient. Connect the USB units directly to the PC, or reduce the number of USB units connected.
Cannot print.	
Printer power is not turned on.	Turn on the printer power.
Printer cable is not connected to the PC.	Connect the printer to the PC.
Printer driver is not installed.	Install the printer driver.
Cannot send and receive e-mail.	
E-mail software settings are not appropriate.	Confirm by checking e-mail software help.
System Controller e-mail settings are not appropriate.	See par. 10. Error E-mail Notification Setting, and check the settings.
Internet provider is shut down for maintenance or other reason.	Wait awhile and then retry, or contact the provider.
The layout edit screen, and property/ building 3D/ floor image will not be displayed.	
In cases such as when the OS is changed (e.g. XP → Vista), the graphic card driver will go into an uninstalled state.	Carry out installation of the necessary driver.

Overall operation is slow.	
System Controller is designed to run on a PC of the specified performance, but the operation speed varies depending on the number of management points and other loads. When the operating speed of the System Controller used appears to be slow, the methods shown at the right will increase the speed.	1. Lighten the processing load 1) Close other applications running on the PC. 2) Change the settings that the load is lightened. Specifically, •Reduce the number of managed units. •Reduce the number of schedules.
	2. Raise the PC specifications. 1) Increase the memory size. 2) Use a high performance PC

Not connected from client PC to server PC.	
Network setting was not performed.	See 6. network setting of this manual and perform network setting.
Port to outside the network is not open.	Contact both the client side and server side network administrator, and confirm that port numbers 9983 and 9984 are open.
VRF Controller not started by server PC.	Start the VRF Controller by server PC.
For internet connection: Client PC side internet provider or service PC side internet provider is shut down for maintenance or other reason.	Wait awhile and then retry, or try contacting the provider.
After import, VRF Controller does not restart.	Restart VRF Controller. (→ See par. 12. Starting and ending the VRF Controller)
Encryption settings do not match.	Match the encryption setting of the VRF Explorer (→ See par. 16-2 site setting) and the encryption setting of the VRF Controller. (→ See par. 13-2 Security setting)

25-2 Error code table

The system controller error codes are shown below. When an error occurred at the system controller, check the codes below and contact your dealer.

Note

The table below includes only the error which occurs on System Controller.
For the error codes of other units(indoor units, outdoor units, etc), refer to the service manual.

Error code	Error contents
F11	Database access error
F12	Database connection error
F13	Software restart error
F14	Program run time error
F15	Error at execution of various special operations
F16	Insufficient vacant space on HDD used by database
F21	Transmission adaptor connection failed
F22	Transmission error (data not acquired)
F23	External input power meter error
F31	Communication between processes error
F32	Software protection key not recognized (including WIBU-KEY obstruction)
F33	Server/client communication error
F41	HDD capacity error
F42	System requirements error
F43	Time error
17	Electricity charge apportionment error → See 9-1. Over view and 8. Electricity charge apportionment error.

26. FAQ

26-1 Frequently asked questions and answers

No.	Question
	Answer
1.	How can I determine if my PC supports DirectX?
	Open the command prompt and execute "dxdiag". Then check "DDI Version" in Display tab is 9 or more.
2.	What units are supported by the temperature display?
	Celsius (°C) and Fahrenheit (°F) are supported. → See par. 11-1-2 Temperature units setting.
3.	I don't want the alarm to sound. Can I stop the alarm from sounding?
	Yes, Uncheck "Sound audible alarm" at the Alarm tab of 11-1 environment setting screen.
4.	The PC power was dropped during unit scanning. What happens to the data scanned up to the point? Is data integrity maintained?
	The scanned data is saved when scanning is completed and the [OK] button is pressed. When the power was dropped before this, the data scanned up to that point is lost. Restart scanning from the beginning. → See par. 8-3-3 Unit registration.
5.	Can the U10 USB Network Interface used with the system controller also be used with service tools and other software?
	The adaptor can also be used with service tools. However, one adaptor cannot be used simultaneously by the system controller and service tools.
6.	What is the difference Secure Reg enable and disable at Unit Registration?
	Secure Reg. enable is a mode which stops operation of all the units and confirms scanning for unit recognition. Secure Reg. disable is a mode which performs scanning in parallel without stopping operation of the units. Since scanning is an important function for recognition of the units to be managed by the system controller, it is recommended that, as a rule, it be performed by enabling Secure Reg. If unavoidable, disable Secure Reg only when scanning must be performed without stopping operation of the units. In any case, whether or not units were recognized correctly must be confirmed after scanning. However, when scanning was performed with Secure Reg disabled, re-scanning may be necessary due to unit recognition misses.
7.	Scanning was performed, but all the units were not recognized. What should I do?
	When work is performed normally and scanning is performed after confirmation and units are not recognized, first check whether or not the power of the unrecognized units is turned off. Other causes may be: <ul style="list-style-type: none"> •Unit trouble •Deterioration of the work state In any case, contact the relevant dealer.
8.	Scanning was performed, and all the units were recognized, but R/C group information is not correct. What should I do?
	Assume an abnormality in the wiring which defines the R/C group or incorrect setting of the address in the indoor unit R/C group. Refer to the service manual and perform setting correctly.
9.	Scanning was performed and all the units were recognized, but the unit information is not correct. What should I do?
	It is possible that communication with the unit is incomplete. Enter a secure reg. check mark and re-scan. → See par. 8-3-3 Unit registration.

No.	Question
	Answer
10.	Scanning takes a very long time. What can I do?
	When the existing refrigerant system numbers are known in advance, the scanning time may be shortened by specifying the refrigerant range to be scanned at the scan execution screen. For example, when rescanning, etc. when recognition by scanning isn't very good, the scanning time can be shortened by specifying the range of only the refrigerant systems at which recognition was poor. In addition, scanning by "secure reg." is faster than scanning "without secure reg.". → See par. 8-3-3 Unit registration.
11.	Can multiple System Controllers be used simultaneously?
	Multiple system controllers cannot be used in one VRF network. → See par. 3-3 Example of use.
12.	I want to replace the server PC with a new PC. Can the data be transferred?
	The system controller has data Export and Import functions. For details, see the Import/Export page.
13.	Unit expansion, replacement, and removal were performed. How can I reflect these changes at the system controller?
	Perform scanning again. → See par. 8-3-3 Unit registration.
14.	VRF system expansion, replacement, and removal were performed.
	After setting the U10 USB Network Interface adaptor correctly, recognize the units by scanning. See par. 8-3-2 Transmission adaptor setting, See par. 8-3-3 Unit registration
15.	I want to inform the system controller if an error occurred at a unit even in the state in which the system controller is not visible.
	Perform error e-mail notification setting and set so that the system controller is informed by e-mail. → See par. 10. Error E-mail Notification Setting.
16.	The state displayed on the screen does not change even though operation setting is performed.
	When operation setting was performed at multiple units or at a group containing multiple units, it may take some time for the state of that unit to change to the set contents.
17.	Can a transmission adaptor (UTR-YTMA) be used with the system controller?
	Transmission adaptor (UTR-YTMA) cannot be used with the system controller. Provide a new U10 USB Network Interface to monitor by system controller an S/V Series monitored by a PC controller via a transmission adaptor.
18.	Can a WIBU-KEY used by a PC controller be used by the system controller?
	Since the PC controller and system controller are separate products, the WIBU-KEY used by the PC controller cannot be used by the system controller.
19.	Do you need a WIBU-key for both server and client PC?
	No, only server PC requires WIBU-key.
20.	When SQL Server 2008 R2 installation failed while the this application is being installed.
	Please refer to the log in the following folder. C:\Program Files\Microsoft SQL Server\100\Setup Bootstrap\Log
21.	The system controller stopped while I was away from my seat for a while.
	When Windows Update was executed in the background, the Operating System automatically reboots and the system controller may stop. In such cases, set so that Windows Update is performed manually and periodically update the Operating System.

26-2 Questions and answers related to electricity charge apportionment

No.	Question
	Answer
1.	Why is an electricity charge generated even though none of the indoor units is being used?
	Since power is consumed by the outdoor unit even when all the indoor units are not in use, an electric charge is generated.
2.	Why isn't the operation time and electric charge proportional?
	If the room temperature is already the set temperature even when operation is turned ON by remote controller, the indoor unit will not operate and the power consumption will be that much lower. In addition, if the difference between the room temperature and the set temperature is large, more power is consumed than when the difference is small. Therefore, the operation time and electricity charge may not necessarily be proportional.
3.	Why is the electricity charge of operated indoor units so much smaller than that of indoor units that are not operated at all?
	Electricity charge includes the power consumed by the outdoor unit in addition to that of the indoor unit. The outdoor unit consumes power constantly so that operation at any time is possible even through indoor units are not operating. This is called "standby power". Since the standby power differs with the model of outdoor unit, if the number of indoor units per outdoor unit is assumed to be the same, the indoor units which use a high standby power outdoor unit will consume more power than indoor units which use a low standby power outdoor unit. This question is an example of when the difference of this standby power was larger than the power consumed by operation. This is a normal result. Generally, this kind of difference is made small by selecting the model of outdoor unit based on appropriate facility design.
4.	Why has the electricity charge suddenly increased even though use is the same as in the past?
	The electricity charge is apportioned between blocks. When the number of blocks is decreased or increased by the leaving and entering of tenants, the electricity charge increases and decreases. As an example, if the case when setting so that the basic charge is apportioned equally by number of blocks, when the number of tenants decreases, apportionment per block increases and when the number of tenants increases, apportionment per block decreases. This phenomenon also varies depending on the electricity apportionment setting method. The building owner and manager should perform appropriate setting in accordance with that policy.

27. Definition Of Terms

Terms	Definition
Group	When a group is set, the operating state can be checked by selecting it one time.
U10 USB Network Interface adaptor	Adaptor for connecting the USB terminal of PC and units.
R/C group, R.C.G.	Minimum units of unit group which receives operation commands.
Filter sign	Sign which shows that the filter cleaning period has arrived. The filter cleaning period is represented by operation for a fixed time.
Anti Freeze	Function which performs low temperature heating operation to prevent trouble due to freezing of water pipes and units when air conditioning operation was stopped in cold regions.
Economy operation (Energy save)	Function which gradually changes the internal set temperature to near the room temperature each time a fixed interval has elapsed after the temperature was set. The set temperature display does not change.
R/C prohibition setting	Setting so that a certain function cannot be performed by local remote controller.
Site	VRF system group or building group connected by one VRF controller.
Local	Connection method when the PC running the client software and the PC running the server software is the same.
Remote	Connection method when the PC running the client software and the PC running the server software are different.
Server PC	PC which is directly connected to the VRF System by using a U10 USB Network Interface adaptor. Server PC is the PC in which VRF Controller is installed and run. A VRF Explorer is also installed to the server PC, and the user can manage VRF System operation by server PC.
Client PC	PC which is connected to a server PC over an internet or other network and manages operation of the VRF System via the server PC. VRF Explorer is installed and run.
Server software	One of the 2 programs making up the System Controller. It communicates with the VRF System and passes status information to the client software and receives operation setting information from the client software. Since the user provides service to the client software (VRF Explorer) used to actually manage operation, it is called server software. Since it is run in the background on the PC, it is difficult to realize that it is running and when running, an icon appears on the task tray. Operations which can be performed by the user related to the client software are related to menus which are displayed by right clicking the icons on the task tray. In this manual and programs, it is referred to by the name VRF Controller. The VRF Controller must be used together with a WIBU-KEY packed with together with this product.
Client software	One of the 2 programs making up the System Controller. It is software used by the user to actually manage operation. Since it communicates with a server directly connected to the VRF network and is run by receiving service from the server, it is called client software. In this manual and programs, it is referred to by the name VRF Explorer. VRF Explorer mainly consists of 2 screens: Site Navigator screen for monitoring group site and VRF Explorer main screen related to a specified site in it. VRF Explorer can be installed to up to 5 PC by using this product. (Including the VRF Explorer in the server PC)
VRF Controller/VrfController	See the server software item.
VRF Explorer/VrfExplorer	See the client software item.
Emergency Stop	State in which operation was forcefully stopped in an emergency such as a fire, etc.

Terms	Definition
RB	RB is the abbreviation for "Refrigerant Branch Unit" used with a heat recovery system. It is installed at the refrigerant piping between outdoor unit and indoor unit to switch the refrigerant circuit in the operation mode of each indoor unit.