



CENTRAL REMOTE CONTROLLER

INSTALLATION MANUAL

For authorized service personnel only.

English

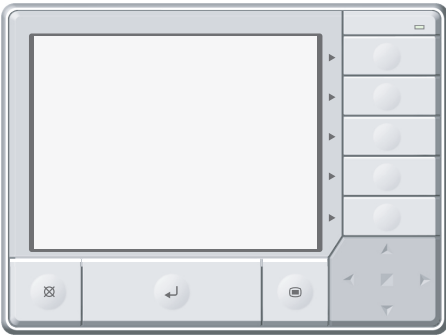

UTY-DCGY
UTY-DCGG

INSTALLATION MANUAL

CENTRAL REMOTE CONTROLLER

Contents

1. SAFETY PRECAUTIONS	1
2. MAIN UNIT AND ACCESSORIES	1
3. ELECTRICAL REQUIREMENT	2
4. SELECTING AN INSTALLATION LOCATION	2
4. 1. Dimensions	2
4. 2. Installation restrictions	3
5. WIRING RULES	3
5. 1. Terminal names	3
5. 2. Wiring rules	3
6. INSTALLATION METHOD	5
6. 1. Selecting the Method of Installation.....	5
6. 2. Preparing Installation	5
6. 3. DIP Switch Setting	6
6. 4. Installation Method - Integrated type	6
6. 5. Installation Method - Separate type.....	7
6. 6. External Input/Output function	9
7. TURNING ON THE POWER	10

1. SAFETY PRECAUTIONS

- The “SAFETY PRECAUTIONS” indicated in the manual contain important information pertaining to your safety. Be sure to observe them.
- For details of the operation method, refer to the operating manual.
- Request the user to keep the manual on hand for future use, such as for relocating or repairing the unit.

⚠ WARNING

This mark indicates procedures which, if improperly performed, might lead to the death or serious injury of the user.

Perform electrical work by an authorized service personnel in accordance with the installation manual and the electrical wiring regulations or implementation regulations of the country. Also do not install this unit by yourself. Improper electric work will cause electric shock or a fire.

Perform installation work in accordance with the installation manual. Request an authorized service personnel to perform installation work. Do not install this unit by yourself. Improper installation will cause injury, electric shock, fire, etc.

In the event of a malfunction (burning smell, etc.), immediately stop operation, turn off the electrical breaker, and consult authorized service personnel.

Install a leakage circuit breaker to power supply cable in accordance with the related laws and regulations and electric company standards.

Use a power source exclusively for this unit. Never share the power source with indoor unit or other electrical equipment. Doing so will cause fire and electric shock.

⚠ WARNING

This mark indicates procedures which, if improperly performed, might lead to the death or serious injury of the user.

Do not install the unit in the following areas:

- Do not install the unit near a source of heat, steam, or flammable gas.
- Area filled with mineral oil or containing a large amount of splashed oil or steam, such as a kitchen. It will deteriorate plastic parts, causing the parts to fail or the unit to leak water.
- Area that generates substances that adversely affect the equipment, such as sulfuric gas, chlorine gas, acid, or alkali. It will cause the copper pipes and brazed joints to corrode, which can cause refrigerant leakage.
- Area containing equipment that generates electromagnetic interference. It will cause the control system to malfunction, and cause erroneous operation.
- Area that can cause combustible gas to leak, contains suspended carbon fibers or flammable dust, or volatile inflammables such as paint thinner or gasoline. If gas leaks and settles around the unit, it can cause a fire.
- Do not use the unit for special purposes, such as storing food, raising animals, growing plants, or preserving precision devices or art objects. It can degrade the quality of the preserved or stored objects.
- Install the unit in a well-ventilated place avoiding rains and direct sunlight.

Do not operate this unit when your hands are wet. Touching the unit with wet hands will cause an electric shock.

When children can approach the unit or touch the unit, take preventive measures.

⚠ CAUTION

This mark indicates procedures which, if improperly performed, might possibly result in personal harm to the user, or damage to property.

Pay abundant care when transporting this unit because it is a precision device. Improper transportation will cause trouble.

Do not touch the switches with sharp objects. Doing so will cause injury, trouble, or electric shock.

Do not expose this unit directly to water. Doing so will cause trouble, electric shock, or heating.







Do not set vessels containing a liquid on this unit. Doing so will cause heating, fire, or electric shock.

Dispose of the packing materials safely. Tear and dispose of the plastic packing bags so that children cannot play with them. There is the danger of suffocation if children play with the original plastic bags.

2. MAIN UNIT AND ACCESSORIES

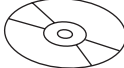
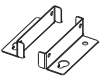
The following parts are supplied. Use them as required.

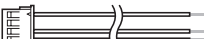
Name and Shape	Q'ty	Application
Central remote controller 	1	Main unit

Name and Shape	Q'ty	Application
Installation manual 	1	This manual
Operating manual 	1	Instruction book for operation
CD-ROM 	1	Include the operating manual for Central remote controller
Holder 	1 (Set)	For power supply unit installation (Used for separate type)
One touch bush 	2	For protection of power supply unit cable
Connection cable 	1	For power supply unit connection
Screw (M4 x 20 mm) 	8	For Central remote controller installation
Binder 	4	Prevents dropping off of the cable

3. ELECTRICAL REQUIREMENT

When connecting the Central remote controller, use the following wiring.

Use	Size	Wire type
Power supply cable	Max.1.25 mm ² (16AWG)	Type60245 IEC57 or equivalent
	Min.0.5 mm ² (20AWG)	
Transmission cable	0.33mm ² (22AWG)	22AWG LEVEL 4 (NEMA) non-polar 2 core, twisted pair solid core diameter 0.65mm (1/32 in.)
External input/output cable	0.33mm ² (22AWG)	2 core, twisted pair (Max.cable length : 25m (82ft.))

Use	Remark
Power supply cable	1Φ 50/60Hz 100-240V 2 wire + earth (ground) (Always earth (ground) the unit)
Transmission cable	LONWORKS® compatible cable
External input/output cable	Use cable in accordance with local rules for cable

* LONWORKS® is registered trademark of Echelon Corporation in the United States and other countries.

Fuse capacity	5 A
---------------	-----

4. SELECTING AN INSTALLATION LOCATION

4. 1. Dimensions

(1) Control unit

Unit: mm (in.)

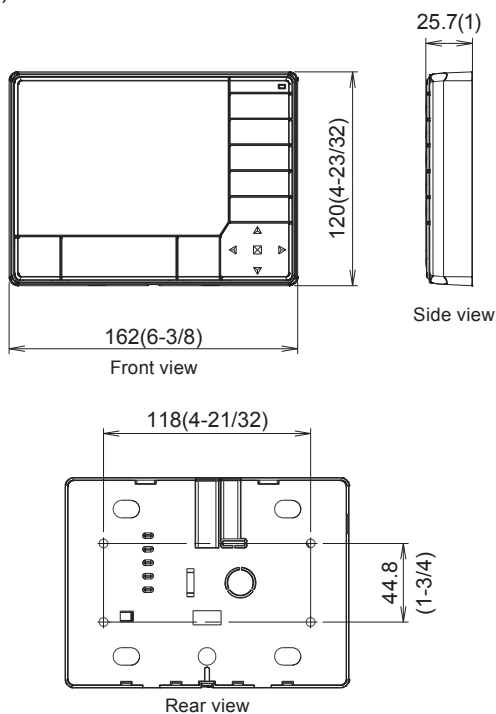

(2) Power supply unit

Unit: mm (in.)

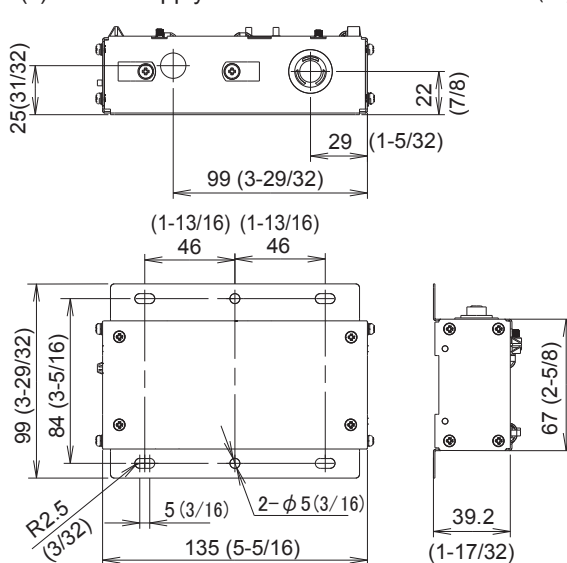

4.2. Installation restrictions

Make a service space to perform installation work.
Unit: mm (in.)

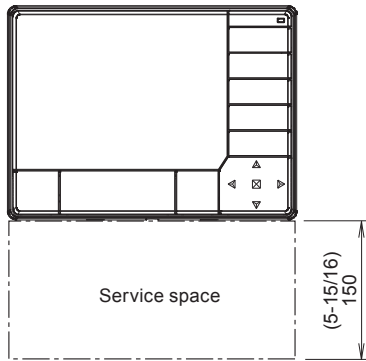

5. WIRING RULES

⚠ WARNING

Always use the accessories and specified installation work parts. Check the state of the installation parts. Not using the specified parts will cause fall, water leakage, electric shock, fire, etc.

Install at a place that can withstand the weight of the unit and install positively so that the unit will not topple or fall.

When installing this unit, make sure that there are no children nearby. Otherwise, injury or electric shock could result.

After this unit is installed, perform a test run to verify that the device operates normally. Then describe the operation method of this unit to the customer.

Install a circuit breaker. Not installing a circuit breaker will cause electric shock or fire.

⚠ CAUTION

Before opening the case of this unit, remove all the static electricity accumulated on the human body. It will cause an accident.

When the front cover fixing screws are removed, be careful that the front cover does not fall off. It will cause an injury.

The circuit boards of this unit are at both the front cover and rear cover. When a cover is opened, the circuit boards may be damaged by the screwdriver. This will cause an accident.

The front cover and rear cover are connected by wiring. When disassembling, be sure that the wiring is not stretched.

Do not touch this unit's circuit board and circuit board parts directly with your hands. Doing so may cause electric shock or injury.

Tightening the mounting screws too tight will damage the case of this unit.

5.1. Terminal names

(1) Power supply unit

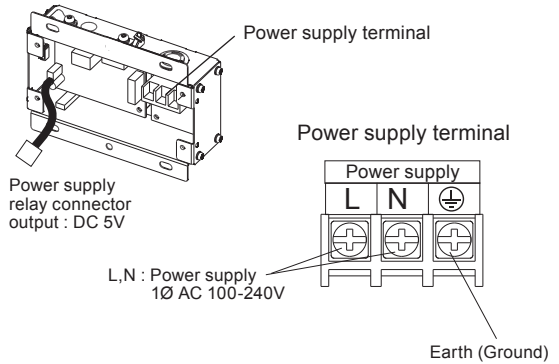

Tightening torque

Screw size M4	1.2 to 1.8 N·m (10.6 to 15.9 lbf·in)
---------------	--------------------------------------

(2) Control unit

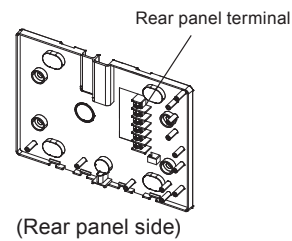

(Rear panel side)

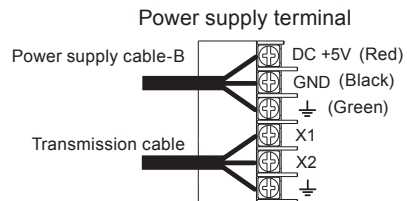

Tightening torque

Screw size M2.6	0.3 to 0.5 N·m (2.7 to 4.4 lbf·in)
-----------------	------------------------------------

5.2. Wiring rules

⚠ WARNING

Before starting installation work, turn off the power of this unit and the connection destination. Do not turn on the power again until installation is completed. Otherwise, it will cause electric shock or fire.

Use the accessories or specified power supply cable and connection cables. Do not modify power supply cable and connection cables other than those specified, do not use extension cables, and do not use independent branch wiring. The allowable current will be exceeded and cause electric shock or fire.

Install the connection cables securely to the terminal block. Confirm that external force is not applied to the cable. Use connection cables made of the specified cable. If intermediate connection or insertion fixing are imperfect, it will cause trouble, electric shock, fire, etc.

⚠ WARNING

When connecting the power supply cable and transmission cable, layout the wiring so that the cover of this unit is securely fixed. If the cover is imperfectly fixed, it may cause fire or overheating of the terminals.

Perform earth (ground) work positively. Do not connect the earth (ground) cable to a telephone earth (ground) cable, water pipe, or conductor rod. It will cause trouble or fire.

Always fasten the outside covering of the cable with binder. If the insulator is chafed by friction, electric leakage may occur.

If any cable is damaged, do not repair or modify it yourself. Improper work will cause electric shock or fire.

⚠ CAUTION

Do not bind up the power supply cable together with the transmission cable or remote controller cable. It will cause erroneous operation.

When performing wiring work, be careful not to damage the cable or injure yourself. Also, connect the connectors securely. Loose connectors will cause trouble, heating, fire, or electric shock.

Install the indoor and outdoor units, power supply cable, transmission cable and remote controller cable 1m (40 in.) away from television and radio to avoid distorted images and noise. Otherwise, a malfunction could result.

Perform wiring so that water does not enter this unit along the external wiring. Always install a trap to the wiring or take other countermeasures. Otherwise it will cause trouble, electric shock, or fire.

Confirm the name of each unit and name of each terminal block of the unit and connect the wiring in accordance with the directions given in the manual so that there is no incorrect wiring. Incorrect wiring will damage the electric parts and cause smoke and fire.

When installing the connection cables near a source of electromagnetic waves, use shielded cable. Otherwise, a breakdown or malfunction could result.

- When wiring between the outdoor unit, indoor unit, and Central remote controller, refer to the indoor unit and outdoor unit installation manuals.
- Always connect both ends of the earth (ground) connection of the transmission cable.
- Install the disconnect switch to the easily accessible location.
- Install the fuse (5A) to the L line of power supply cable.

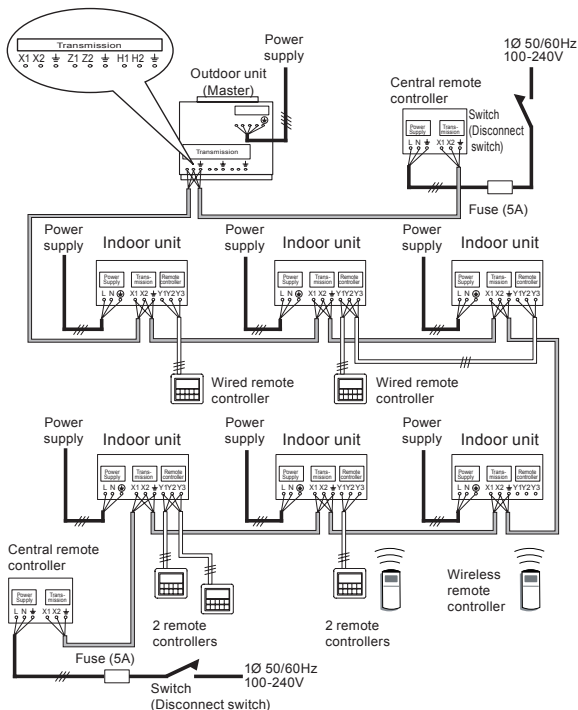

- Wire the transmission cable to any one of the following:
 - ① Transmission terminal block inside the indoor unit (Fig. 1)
 - ② Terminal block for branch Transmission cable (Procured at the site) (Fig. 2)
 - ③ Transmission terminal block inside the outdoor unit (Fig. 3)

Fig. 1

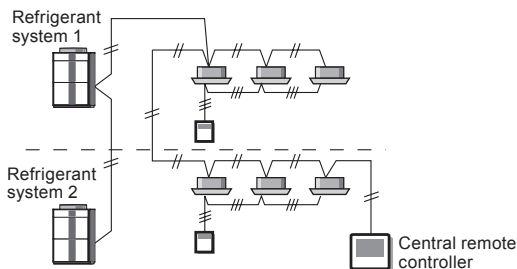

Fig. 2

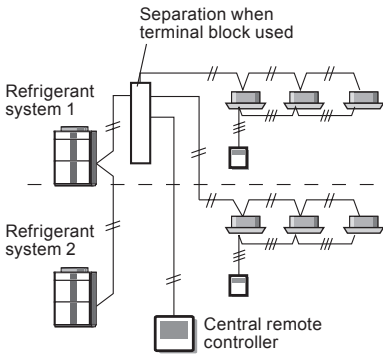
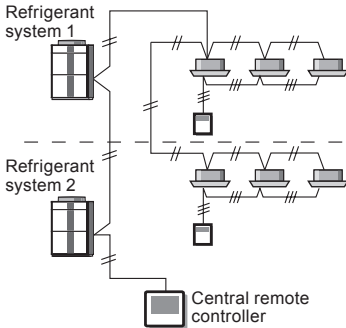

Fig. 3



6. INSTALLATION METHOD

6.1. Selecting the Method of Installation

The following are the 2 methods for installing the central remote controller based upon the installation method of the control unit and power supply unit.

- A. Control unit and power supply unit together (Fig. A)
- B. Control unit and power supply unit separately (Fig. B)

Fig. A

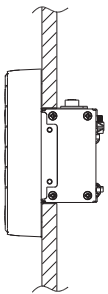
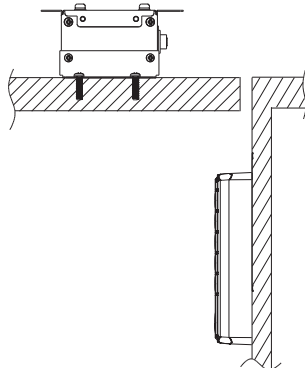

Fig. B



6.2. Preparing Installation

6.2.1 Controller unit

- (1) Remove the screw (1 pc).
- (2) Remove the claws (2 places) with a flat-blade screwdriver, and separate the front panel and rear panel.

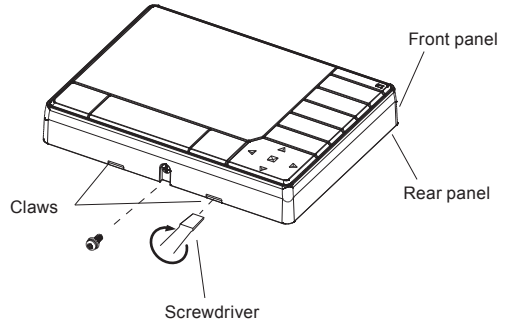

- (3) Disconnect the connection cable connector from the connector (CN13) of the front panel PC board.

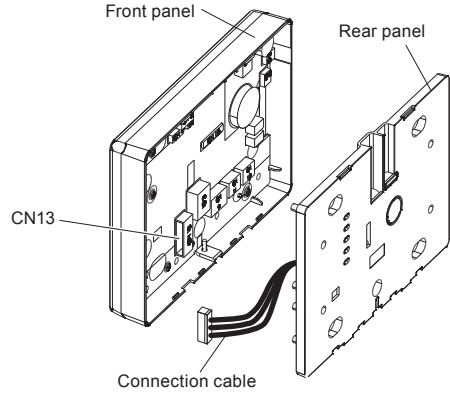

6.2.2 Power supply unit

- (1) Remove the screws (4pcs).
- (2) Remove the cover.

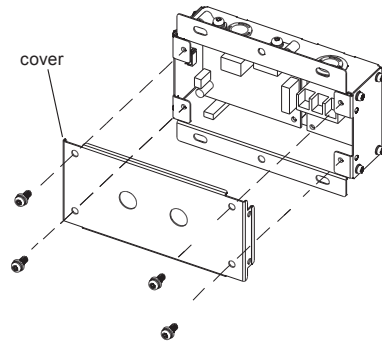

6. 3. DIP Switch Setting

⚠ CAUTION

Use an insulated screwdriver to set the DIP switches. Do not touch the DIP switch with your hands.

- Before using this product, always set DIP switch (SW1)-No.1 to "ON". If not set, when the main power is turned on again, the set data by menu operation will be erased and cause erroneous operation.
- Do not change the setting of other switches.

[DIP Switch(SW1)]

- Performs the enabling/disabling of the backup function by the internal battery.
- It is disabled when shipped from the factory to prevent consumption of the charge.

DIP Switch (SW1)

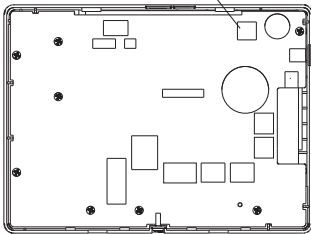

No.	DIP Switch		Details
	OFF	ON	
1	★Disabled	Enabled	For enabling/disabling the backup function.
2	★	-	Not used. Fixed to "OFF".
3	★	-	Not used. Fixed to "OFF".

(★:Factory setting)

6. 4. Installation Method - Integrated type

6. 4. 1 Integrated type

- Pass power supply cable-A through Hole-A, and connect it to the power supply terminal of the power supply unit PC board.
- Fix with the binder.

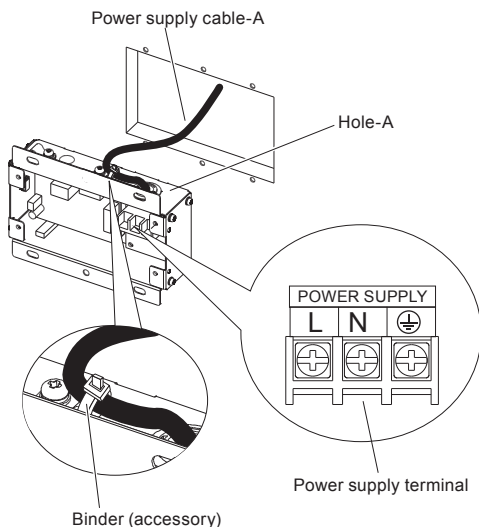

- Open the knockouts (2 places), and install the one touch bush (2 pcs, accessories).
- Connect the connector of power supply cable-B (accessory) to the relay connector of the cable coming from the power supply unit PC board.

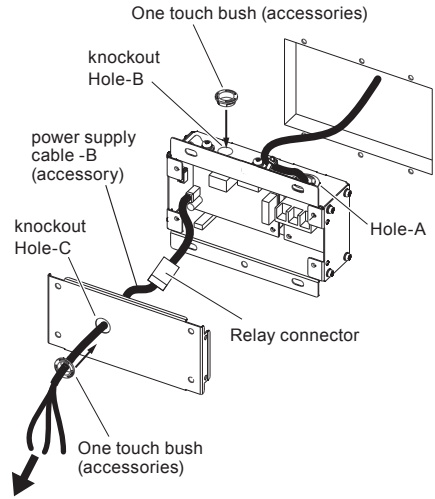

- Pass power supply cable-B through Hole-C and Hole-D, and connect it to rear panel terminal.
- Pass transmission cable through Hole-B, Hole-C, and Hole-D, and connect it to rear panel terminal. Fix with the binder(accessory).

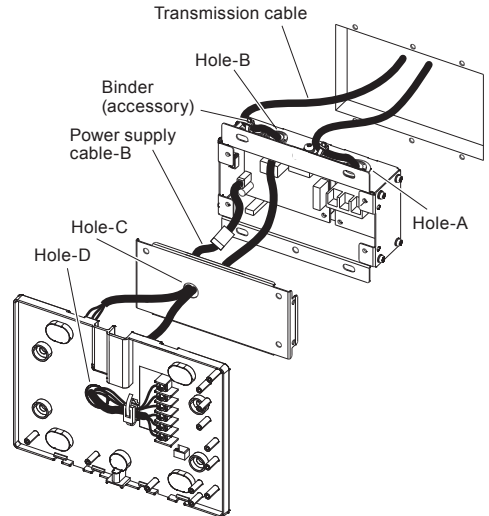

- Fix with the binder (accessory).

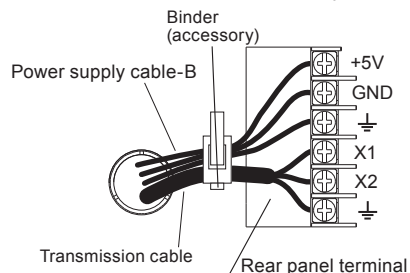

Take care so that the earth (ground) cable does not get into touch with other cables and parts.

- (8) Install the power supply unit to a wall. Then install the power supply unit cover and rear panel. Be careful not to pinch the cable.

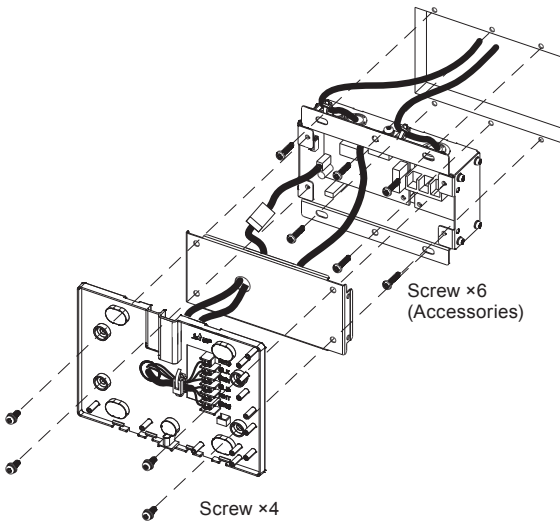

- (9) Connect the connection cable connector to the connector (CN13) of the front panel PC board.
 (10) Install the front panel to the rear panel.

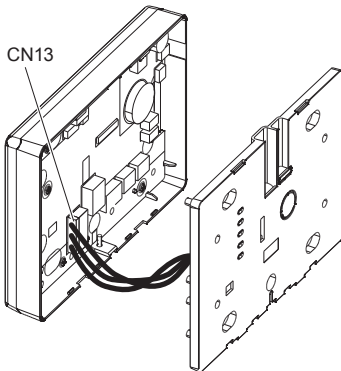

* When installing the front panel to the rear panel, install it carefully so that the cable is not pinched or the parts of the circuit board are not pushed by things projecting from the rear panel. The circuit board parts may be damaged.

- (11) Install the screw (1 pc) and fix the panels.

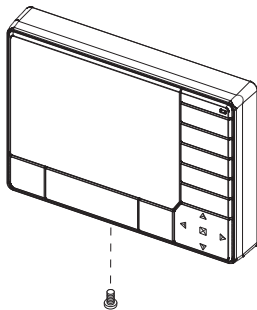

6. 5. Installation Method - Separate type

For the cable, use the service parts to connect the power supply unit and control unit.

Service parts

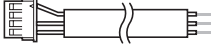
Name and Shape	Q'ty	Application
 Extension cable (5m)	1	9708798011

A. Power supply unit wiring

- Pass power supply cable-A through Hole-A, and connect it to the power supply terminal of the power supply unit PC board.
- Fix with binder firmly.

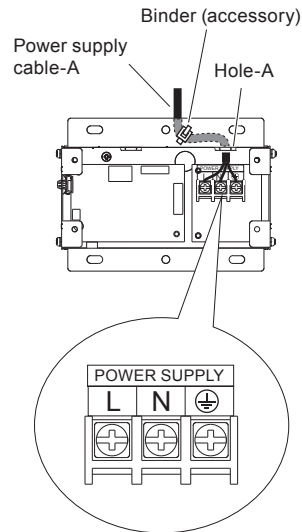

- Open the knockout of hole-B section, and install the one touch bush.
- Pass the extension cable (Service parts) through Hole-B, and connect it to the relay connector coming from the power supply unit.
- Fix with binder firmly.

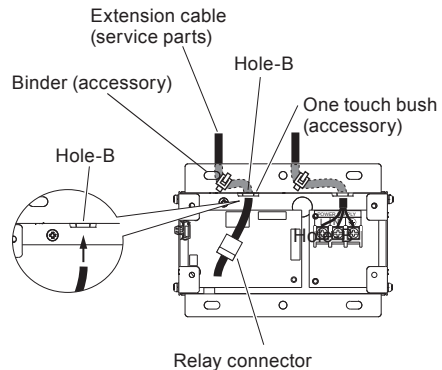

- Install the power supply unit cover, and tighten the screws (4 pcs).

- (7) Fix the holder 1 assembly (2 places) with screws (2 pcs x 2 places).

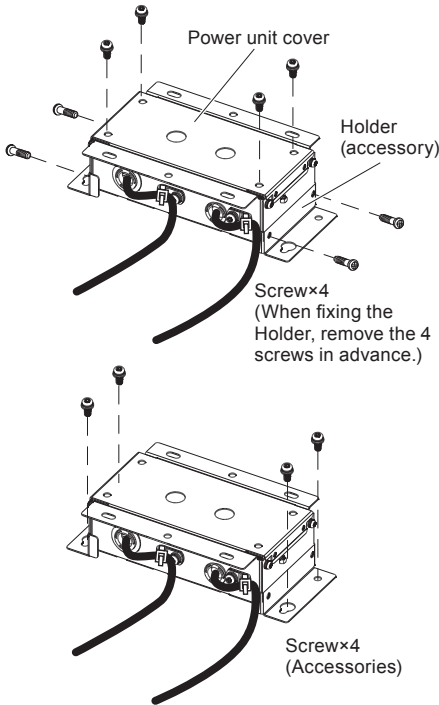

B. Controller body wiring

- (1) Pull around the transmission cable as shown in the figure, and connect it to the terminal of the rear panel.
- (2) Pull around the extension cable as shown in the figure, and connect it to the terminal of the rear panel. And fix with binder firmly.

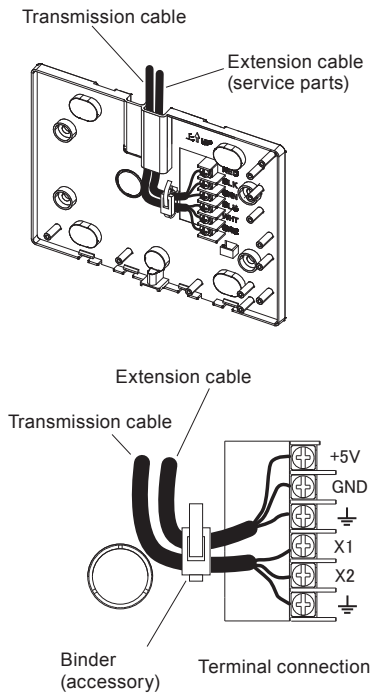

- (3) Install the rear panel to a wall.

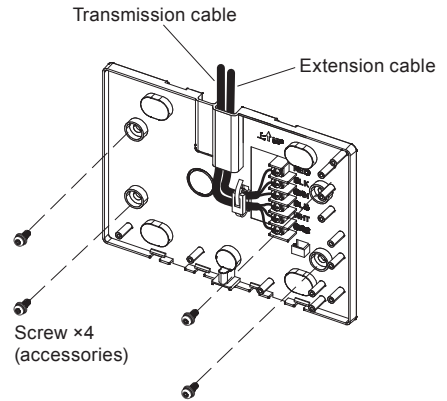

- (4) Cut the thin part (gray marked part) at the top of the front panel with a cutter.

★ When passing the cable through the rear hole, do not cut off the thin part at the top.

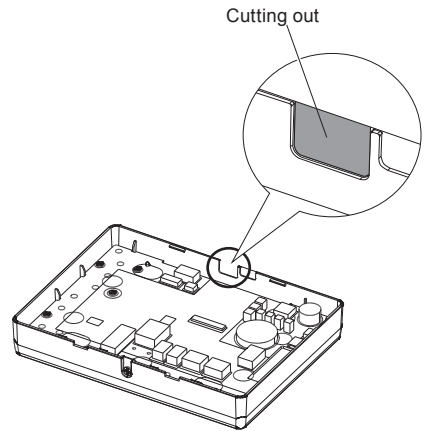

- (5) Connect the connection cable connector to the connector (CN13) of the front panel PC board.

- (6) Install the front panel to the rear panel.

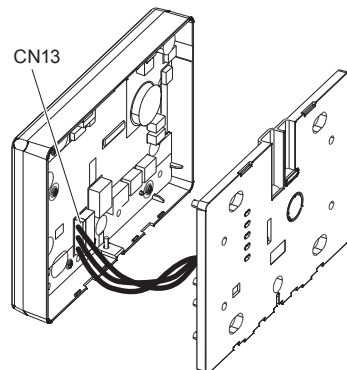

* When installing the front panel to the rear panel, install it carefully so that the cable is not pinched or the parts of the circuit board are not pushed by things projecting from the rear panel. The circuit board parts may be damaged.

(7) Install the screw (1 pc) and fix the panels

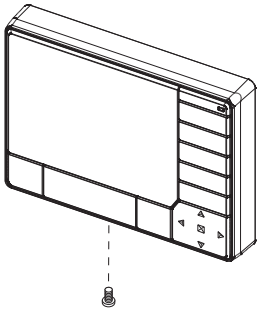

6. 6. External Input/Output function

For connection cables, use the specified optional parts.

6. 6. 1 External input function

This function performs "Emergency stop" or "Batch start/stop(All On/All Off)" by using the signal to be input externally at external input terminals.

There are 2 kinds of input method of External input terminal: "Dry contact" or "Apply voltage contact".

6. 6. 2 Dry contact

When a power supply is unnecessary at the input device you want to connect, connect the connection cables to CN6 and CN7.

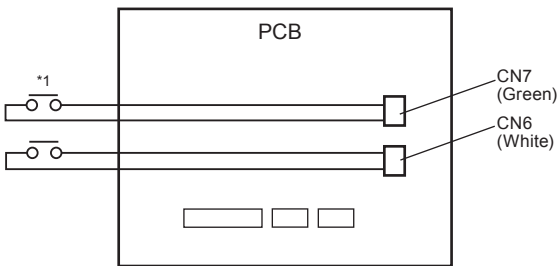

* Do not use the connectors other than specified connectors.

*1. Short circuit detection resistance (R ON) : ≤ 500 (ohm).
Open circuit detection resistance (R OFF) : ≥ 100 (kilo-ohm).

* A twisted pair cable (0.33mm² (22AWG)) should be used.
Maximum length of cable is 25 m (82ft.).

Input Method	Terminal	Input signal	Operation
Edge	CN6	Low→High	"Emergency stop" or "All On"
		High→Low	"Emergency stop"reset or "All Off"
Pulse	CN6	Low→High	"Emergency stop" or "All On"
	CN7	Low→High	"Emergency stop"reset or "All Off"

For "Operation" and "Input method" switching, perform the settings by "External Input Setting" of menu operation.

For details of setting method, refer to the operating manual.

"Operation"	"Emergency Stop"
	"All On/All Off" (Batch start/stop)
"Input Method"	"Edge"
	"Pulse"

6. 6. 3 Apply voltage contact

When a power supply must be provided at the input device, connect the connection cables to CN11 and CN12.

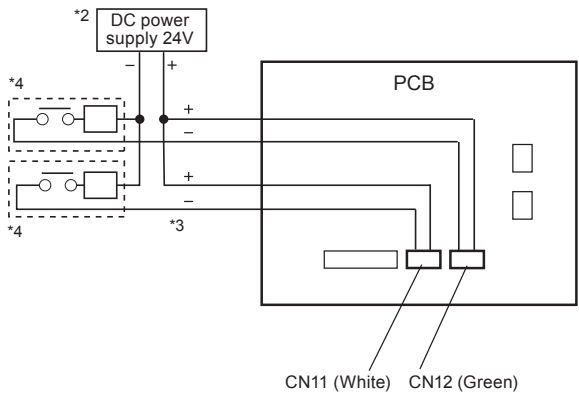

* Do not use the connectors other than specified connectors.

*2. Make the power supply 24V. Select a power supply capacity with an ample surplus for the connected load.

*3. Do not impress a voltage exceeding 24V across pin 1, 3.

*4. The allowable current is DC5mA or less. (Recommended DC5mA)

Provide a load resistance such that the current becomes DC5mA or less.

A twisted pair cable (0.33mm² (22AWG)) should be used.
Maximum length of cable is 25 m (82ft.).

Input Method	Terminal	Input signal	Operation
Edge	CN11	Low→High	"Emergency stop" or "All On"
		High→Low	"Emergency stop"reset or "All Off"
Pulse	CN11	Low→High	"Emergency stop" or "All On"
	CN12	Low→High	"Emergency stop"reset or "All Off"

For "Operation" and "Input method" switching, perform the settings by "External Input Setting" of menu operation.

For details of setting method, refer to the operating manual.

"Operation"	"Emergency Stop"
	"All On/All Off" (Batch start/stop)
"Input Method"	"Edge"
	"Pulse"

6. 6. 4 External output function

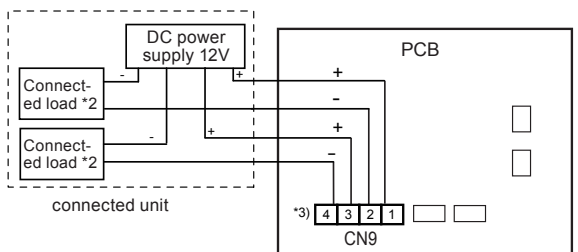

- *1. Provide a DC12V power supply. Select a power supply capacity with an ample surplus for the connected load. Do not impress a voltage exceeding 12V across pins 1-2, and 3-4
- *2. The allowable current is DC15mA or less. Provide a load resistance such that the current becomes DC15mA or less.
- *3. Polarity is [+] for pins 1,3 and [-] for pins 2,4.

Terminal	CH	pin	Condition
CN9	CH1	4	12V: 1 or more registered indoor units are operating.
		3	0V: All registered indoor units are stopped.
	CH2	2	12V: (1) An error occurs at 1 or more registered indoor unit. (2) An error occurs at remote controller.
		1	0V: (1) All registered indoor units are operating normally. (2) Remote controller is operating normally.

6. 6. 5 Wiring method

When using the external input/output function, the connection cable is drawn out as shown in the figure below. Fix the connection cable securely using the binder.

Ex. 1: When the cable is drawn out from the top of this unit:

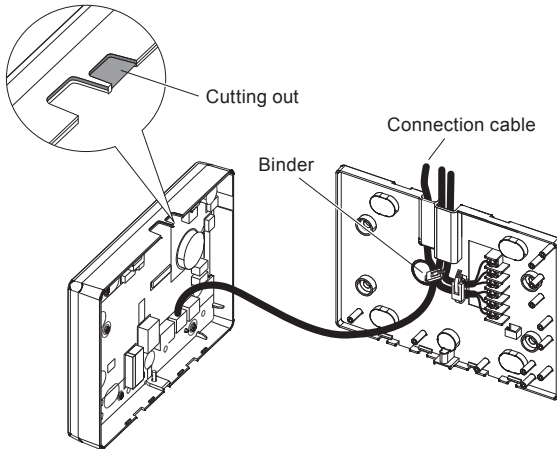

Ex. 2: When the cable is drawn out from the back of this unit:

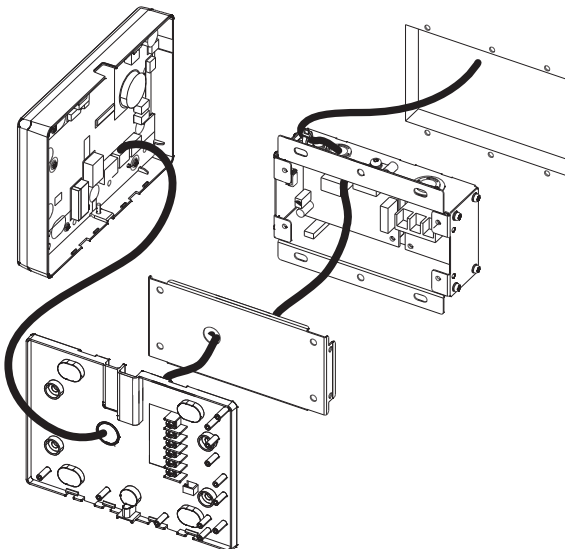

7. TURNING ON THE POWER

⚠ CAUTION

- Check that the power supply voltage is within the specified range. If a power supply voltage outside the specification is input, it will cause trouble.
- Recheck the wiring. Incorrect wiring will cause trouble.

After installation work is completed, check the following contents:

- ① Is Central remote controller power supply cable and transmission cable wiring work complete?
- ② Does the power supply match the rating of the Central remote controller?
- ③ Turn on the power of Central remote controller. Since there is no power switch at this controller main unit, turn on the power by means of the power distribution panel (breaker).
- ④ If the following installer setting screen is displayed at the screen of the Central remote controller panel, installation work is complete.

For setting and operating of the Central remote controller, refer to the separate operating manual.

* Since there is some kind of a problem when the installer setting screen does not appear, recheck the work contents.

