

UTY-DTGY

UTY-DTGG

INSTALLATION MANUAL

TOUCH PANEL CONTROLLER

For authorized service personnel only.

English

INSTALLATIONSANLEITUNG

SENSORBILDSCHIRMSTEUERUNG

Nur für autorisiertes Fachpersonal.

Deutsch

MANUEL D'INSTALLATION

CONTRÔLEUR DE PANNEAU À CONTACT

Pour le personnel agréé uniquement.

Français

MANUAL DE INSTALACIÓN

CONTROLADOR DE PANEL DE CONTACTO

Únicamente para personal de servicio autorizado.

Español

MANUALE DI INSTALLAZIONE

DISPOSITIVO DI CONTROLLO DI PANNELLO A CONTATTO

A uso esclusivo del personale tecnico autorizzato.

Italiano

ΕΓΧΕΙΡΙΔΙΟ ΕΓΚΑΤΑΣΤΑΣΗΣ

ΟΘΟΝΗ ΑΦΗΣ ΧΕΙΡΙΣΜΟΥ

Μόνο για εξουσιοδοτημένο τεχνικό προσωπικό.

Ελληνικά

MANUAL DE INSTALAÇÃO

CONTROLADOR DE PAINEL DE TOQUEY

Apenas para técnicos autorizados.

Português

РУКОВОДСТВО ПО УСТАНОВКЕ

КОНТРОЛЛЕР С СЕНСОРНОЙ ПАНЕЛЬЮ

Только для авторизованного обслуживающего персонала.

Русский

MONTAJ KILAVUZU

DOKUNMATİK PANELLİ KUMANDA

Yalnızca yetkili servis personeli için.

Türkçe

安装说明书

触摸屏控制器

仅针对授权的专业维修人员。

中文

INSTALLATION MANUAL

PART NO. 9378850026
TOUCH PANEL CONTROLLER

Contents

1. SAFETY PRECAUTIONS	1
2. MAIN UNIT AND ACCESSORIES	1
3. ELECTRICAL REQUIREMENT	2
4. SELECTING AN INSTALLATION LOCATION	2
4. 1. Dimensions	2
4. 2. Installation restrictions	2
5. INSTALLING THE TOUCH PANEL CONTROLLER	2
5. 1. Installation preparations	3
5. 2. Terminal names	3
5. 3. External input function	4
5. 4. Wiring	5
5. 5. Installation method	6
6. TURNING ON THE POWER	6

1. SAFETY PRECAUTIONS

- The "SAFETY PRECAUTIONS" indicated in the manual contain important information pertaining to your safety. Be sure to observe them.
- For details of the operation method, refer to the operating manual.
- Request the user to keep the manual on hand for future use, such as for relocating or repairing the unit.

WARNING

This mark indicates procedures which, if improperly performed, might lead to the death or serious injury of the user.

Perform electrical work by an authorized service personnel in accordance with the installation manual and the electrical wiring regulations or implementation regulations of the country. Also do not install this unit by yourself. Improper electric work will cause electric shock or a fire.

Perform installation work in accordance with the installation manual. Request an authorized service personnel to perform installation work. Do not install this unit by yourself. Improper installation will cause injury, electric shock, fire, etc.

In the event of a malfunction (burning smell, etc.), immediately stop operation, turn off the electrical breaker, and consult authorized service personnel.

Install a leakage circuit breaker to power supply cable in accordance with the related laws and regulations and electric company standards.

Use a power source exclusively for this unit. Never share the power source with indoor unit or other electrical equipment. Doing so will cause fire and electric shock.

Do not install the unit in the following areas:

- Do not install the unit near a source of heat, steam, or flammable gas.
- Area filled with mineral oil or containing a large amount of splashed oil or steam, such as a kitchen. It will deteriorate plastic parts, causing the parts to fail or the unit to leak water.
- Area that generates substances that adversely affect the equipment, such as sulfuric gas, chlorine gas, acid, or alkali. It will cause the copper pipes and brazed joints to corrode, which can cause refrigerant leakage.
- Area containing equipment that generates electromagnetic interference. It will cause the control system to malfunction, and cause erroneous operation.
- Area that can cause combustible gas to leak, contains suspended carbon fibers or flammable dust, or volatile inflammables such as paint thinner or gasoline. If gas leaks and settles around the unit, it can cause a fire.

- Do not use the unit for special purposes, such as storing food, raising animals, growing plants, or preserving precision devices or art objects. It can degrade the quality of the preserved or stored objects.
- Install the unit in a well-ventilated place avoiding rains and direct sunlight.

Do not operate this unit when your hands are wet. Touching the unit with wet hands will cause an electric shock.

If children may approach the unit, take preventive measures so that they cannot reach the unit.

This device is a CISPR22 Class A product. In a home environment, this unit may generate radio wave interference. In that case, the user must take appropriate countermeasures.

CAUTION

This mark indicates procedures which, if improperly performed, might possibly result in personal harm to the user, or damage to property.

Pay abundant care when transporting this unit because it is a precision device. Improper transportation will cause trouble.

Do not touch the switches with sharp objects. Doing so will cause injury, trouble, or electric shock.

Do not expose this unit directly to water. Doing so will cause trouble, electric shock, or heating.





Do not set vessels containing a liquid on this unit. Doing so will cause heating, fire, or electric shock.



Dispose of the packing materials safely. Tear and dispose of the plastic packing bags so that children cannot play with them. There is the danger of suffocation if children play with the original plastic bags.

Do not insert articles into the slit parts of this unit. Doing so will cause trouble, heating, or electric shock.

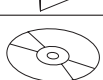
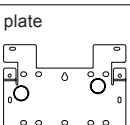
2. MAIN UNIT AND ACCESSORIES

The following parts are supplied. Use them as required.

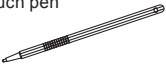
Name and Shape	Q'ty	Application
Touch panel controller 	1	Main unit
Installation manual 	1	This manual
Operating manual 	1	Instruction book for operation
CD-ROM 	1	Include the operating manual for this controller
Installation plate 	1	For Touch Panel Controller installation (it is attached to the back of the Touch Panel Controller)
Screw (M4 x 20 mm) 	8	Screw for touch panel controller installation
Washer 	8	Washer for touch panel controller installation

Touch pen 	1	Pen for touch panel controller operation
Binder 	4	Prevents dropping off of the cable

3. ELECTRICAL REQUIREMENT

When connecting the Touch Panel Controller, use the following wiring.

Use	Size	Wire type
Power supply cable	Max.1.25 mm ² (16AWG)	Type 60245 IEC 57 or equivalent
	Min.0.5 mm ² (20AWG)	
Transmission cable	0.33mm ² (22AWG)	22AWG LEVEL 4 (NEMA) non-polar 2 core, twisted pair solid core diameter 0.65mm (1/32 in.)
External input cable	0.33mm ² (22AWG)	2 core, twisted pair (Max. cable length : 25m (82ft.))

Use	Remark
Power supply cable	1Φ 50/60Hz 100-240V 2 wire + earth (ground) (Always earth (ground) the unit)
Transmission cable	LONWORKS® compatible cable
External input cable	Use cable in accordance with local rules for cable

* LONWORKS® is registered trademark of Echelon Corporation in the United States and other countries.

Fuse capacity	5 A
---------------	-----

4. SELECTING AN INSTALLATION LOCATION

4.1. Dimensions

- Touch panel controller main unit and installation plate

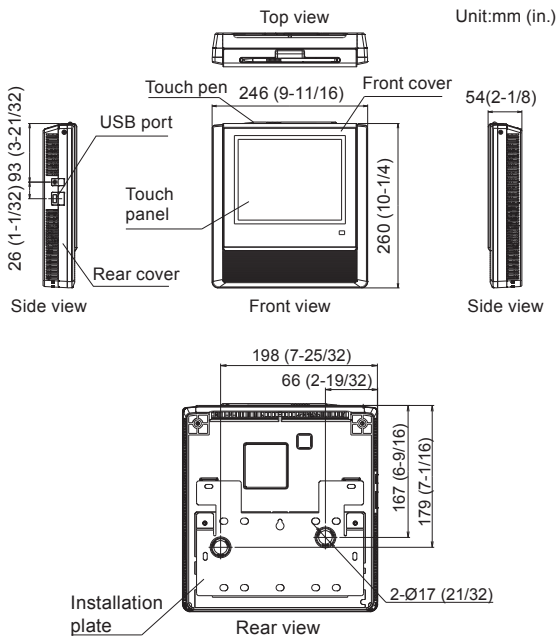

* For the screw position dimensions of the installation plate, see page 4.

4.2. Installation restrictions

- Surrounding space
Provide the following space when installing touch panel controllers in a row and also provide the following space from the projecting parts of the surroundings.

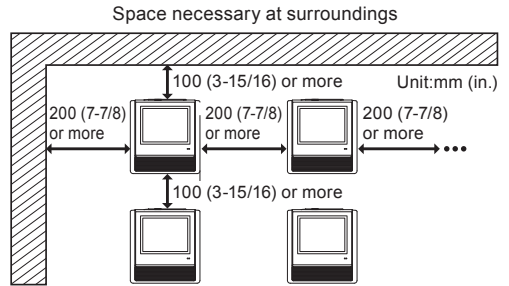

- * Minimize the horizontal and vertical tilts of the switch box installed at the installation site in advance.

- Installation layout

When installing the touch panel controller, installation layouts such as these are not allowed.



5. INSTALLING THE TOUCH PANEL CONTROLLER

⚠ WARNING

Always use the accessories and specified installation work parts. Check the state of the installation parts. Not using the specified parts will cause fall, water leakage, electric shock, fire, etc.

Install at a place that can withstand the weight of the unit and install positively so that the unit will not topple or fall.

When installing this unit, make sure that there are no children nearby. Otherwise, injury or electric shock could result.

After this unit is installed, perform a test run to verify that the device operates normally. Then describe the operation method of this unit to the customer.

Install a circuit breaker. Not installing a circuit breaker will cause electric shock or fire.

⚠ CAUTION

Before opening the case of this unit, remove all the static electricity accumulated on the human body. It will cause an accident.

When the front cover fixing screws are removed, be careful that the front cover does not fall off. It will cause an injury.

The circuit boards of this unit are at both the front cover and rear cover. When a cover is opened, the circuit boards may be damaged by the screwdriver. This will cause an accident.

The front cover and rear cover are connected by wiring. When disassembling, be sure that the wiring is not stretched.

Do not touch this unit's circuit board and circuit board parts directly with your hands. Doing so may cause electric shock or injury.

Tightening the mounting screws too tight will damage the case of this unit.

When inserting the hooks, do not push them in unreasonably. Doing so may damage or deform the claws.

Do not operate the surface of the touch panel with other than the accessory touch pen or your finger. It will scratch the surface and cause trouble.

5.1. Installation preparations

- Make ready the touch panel controller.

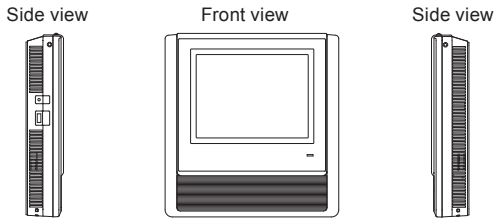

- (1) Remove the ① screw at 2 places at the top of both sides of the touch panel controller. (Fig. 1)
- (2) Separate the front cover part and the rear cover part.
- (3) Hook your finger at the notched part indicated by arrow ② and the rear cover and open in the direction of arrow ③. (Fig. 1)
- (4) Connect the front cover and rear cover and grasp and pull out the connector of the ④ connection cable. (Fig. 1)

Fig. 1

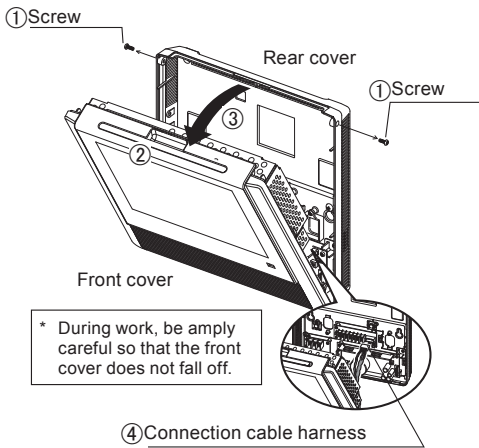

- (5) Remove the installation plate ⑤ fixing screws at 2 places from the inside of the rear cover. (Fig. 2)

Fig. 2

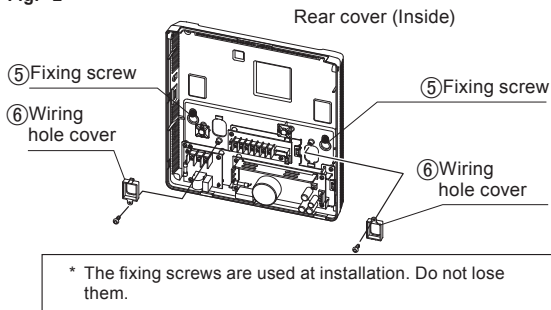

- (6) Installation plate dimensional drawing
Separate the installation plate from the rear cover. (Fig. 3)
Remove the screw at 2 places of the ⑥ wiring hole and remove the wiring hole cover. (Fig. 2)

Fig. 3

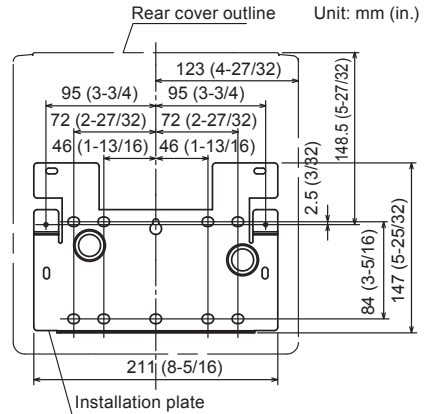
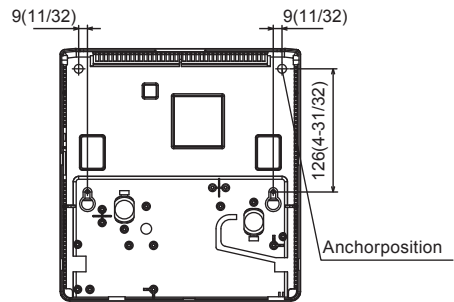

Fig. 4



- * Refer to the dimensional drawing and verify the consistency of the hole positions of the installation screws of the switch box to be installed in advance. (Fig. 4)

5.2. Terminal names

- Terminal names: Names of connection terminals inside the rear cover

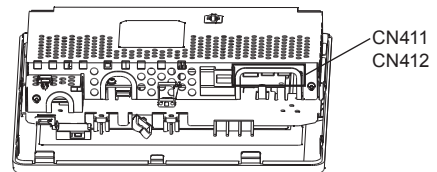
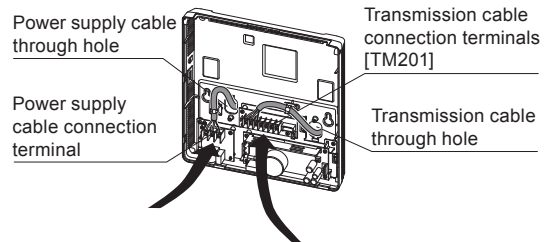

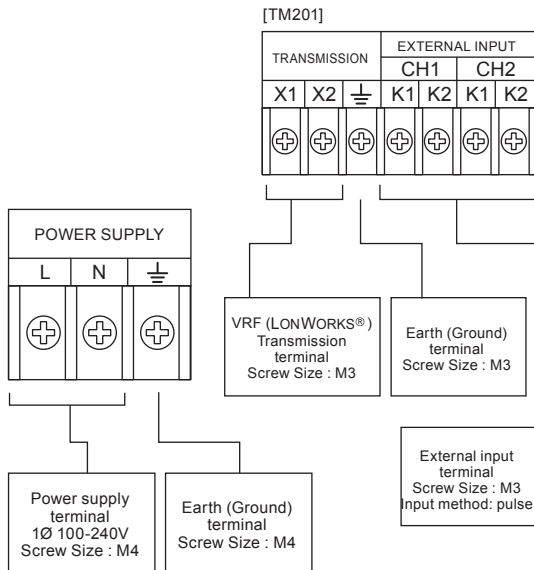

5.3. External input function

- External input terminals:
Function which uses external input terminals to perform the "Emergency stop" or "Batch start/batch stop" operation from the outside.
- External input contact
CH1 and CH2 of TM201 of the rear cover are switched to "dry contact terminal" and "apply voltage terminal" by connecting CN201 on the front cover PCB to CN411 or CN412.

TM201- CH1, CH2	Connect with the CN201
Dry contact terminal	CN411 *
Apply voltage terminal	CN412

* :Factory setting

- Dry contact terminal
When a power supply is unnecessary at the input device you want to connect, connect CN201 and CN411.

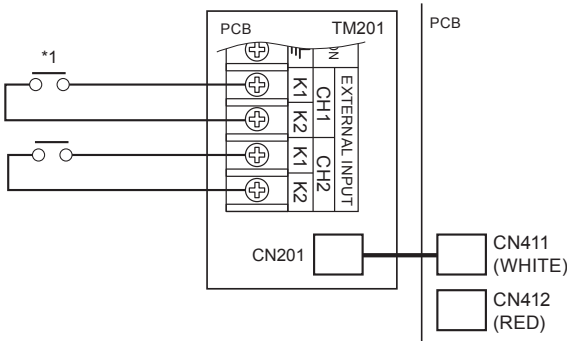

- *1. Short circuit detection resistance (R ON) : $\leq 500 (\Omega)$.
Open circuit detection resistance (R OFF) : $\geq 100 (k\Omega)$.
* A twisted pair cable $0.33mm^2$ (22AWG) should be used. Maximum length of cable is 25m (82 ft.).

- Apply voltage terminal
When a power supply must be provided at the input device, connect CN201 and CN412.

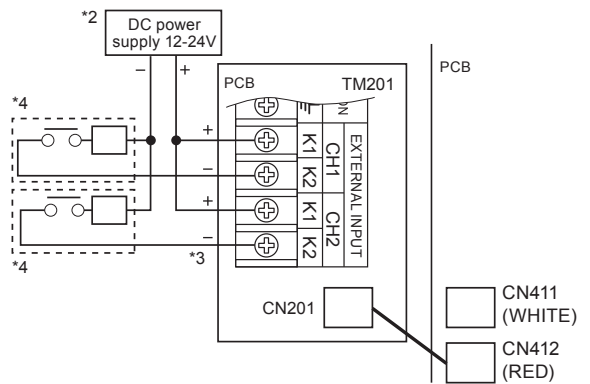

- *2. Make the power supply DC12 to 24V. Select a power supply capacity with an ample surplus for the connected load.
- *3. Do not impress a voltage exceeding 24V across K1-K2.
- *4. The allowable current is DC10mA or less. (Recommended DC5mA)
Provide a load resistance such that the current becomes DC10mA or less.
Select very low current use contacts (usable at DC12V, DC1mA or less).
A twisted pair cable $0.33mm^2$ (22AWG) should be used. Maximum length of cable is 25m (82 ft.).
- The function of the external input terminals is disabled at the factory. Select to match the application.
* Turn on the power and select by installer setting after starting the application.

Emergency stop
Batch start/stop
Not used (disabled)

- Input signal type
When a setting other than "not used" was set by function selection, select the input signal type.

Edge	CH1	Operates from de-energized state to energizing 300ms or more between K1 and K2.	Emergency stop or batch start
	CH1	Operates from energized state to de-energizing 300ms or more between K1 and K2.	Emergency stop reset or batch stop
Pulse	CH1	Operates from de-energized state to energizing 300ms or more between K1 and K2 of CH1.	Emergency stop or batch start
	CH2	Operates from de-energized state to energizing 300ms or more between K1 and K2 of CH2.	Emergency stop reset or batch stop

- * Select Edge/Pulse by installer setting after turning on the power and starting the application.
- * When Edge was selected, only CH1 can be used. CH2 cannot be used.

5. 4. Wiring

⚠ WARNING

Before starting installation work, turn off the power of this unit and the connection destination. Do not turn on the power again until installation is completed. Otherwise, it will cause electric shock or fire.

Use the accessories or specified power supply cable and connection cables. Do not modify power supply cable and connection cables other than those specified, do not use extension cables, and do not use independent branch wiring. The allowable current will be exceeded and cause electric shock or fire.

Install the connection cables securely to the terminal block. Confirm that external force is not applied to the cable. Use connection cables made of the specified cable. If intermediate connection or insertion fixing are imperfect, it will cause trouble, electric shock, fire, etc.

When connecting the power supply cable and transmission cable, layout the wiring so that the cover of this unit is securely fixed. If the cover is imperfectly fixed, it may cause fire or overheating of the terminals.

Perform earth (ground) work positively. Do not connect the earth (ground) cable to a telephone cable, water pipe, or conductor rod. It will cause trouble or fire.

Always fasten the outside covering of the cable with binder. If the insulator is chafed by friction, electric leakage may occur.

Perform all wiring works so that the user does not touch the wiring. Otherwise, injury or electric shock could result.

If any cable is damaged, do not repair or modify it yourself. Improper work will cause electric shock or fire.

⚠ CAUTION

Do not bind up the power supply cable together with the transmission cable or remote controller cable. It will cause erroneous operation.

When performing wiring work, be careful not to damage the cable or injure yourself. Also, connect the connectors securely. Loose connectors will cause trouble, heating, fire, or electric shock.

Install the indoor and outdoor units, power supply cable, transmission cable and remote controller cable 1m (40in.) away from television and radio to avoid distorted images and noise.

Perform wiring so that water does not enter this unit along the external wiring. Always install a trap to the wiring or take other countermeasures. Otherwise it will cause trouble, electric shock, or fire.

Confirm the name of each unit and name of each terminal block of the unit and connect the wiring in accordance with the directions given in the manual so that there is no incorrect wiring. Incorrect wiring will damage the electric parts and cause smoke and fire.

When installing the connection cables near a source of electromagnetic waves, use shielded cable. Otherwise, a breakdown or malfunction could result.

- When wiring between the outdoor unit, indoor unit, and touch panel controller, refer to the indoor unit and outdoor unit installation manuals.
- Always connect both ends of the earth (ground) connection of the transmission cable.
- Install the disconnect switch to the easily accessible location.
- Install the fuse (5A) to the L line of power supply cable.

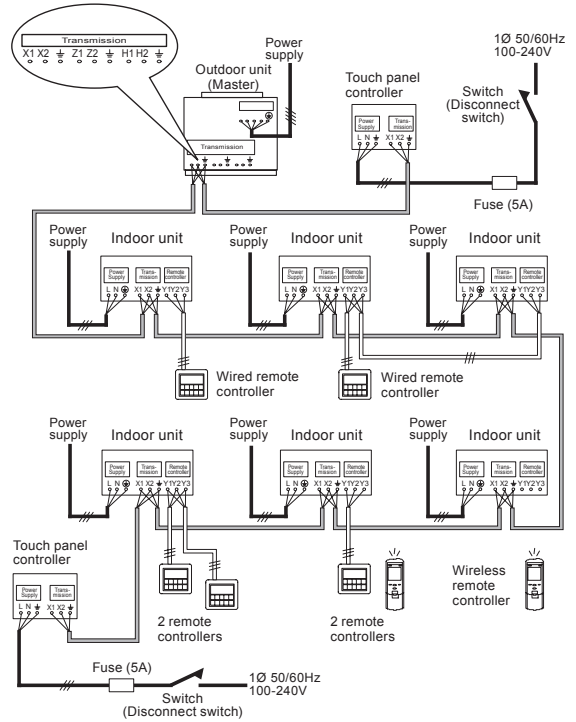

- Wire the transmission cable to any one of the following:
 - ① Transmission terminal block inside the indoor unit (Fig. 1)
 - ② External terminal block (Field supplied) (Fig. 2)
 - ③ Transmission terminal block inside the outdoor unit (Fig. 3)

Fig. 1

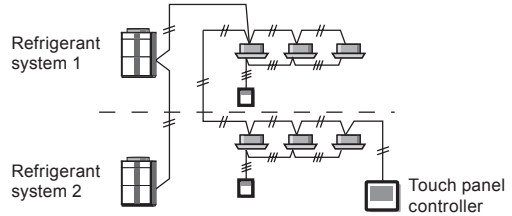

Fig. 2

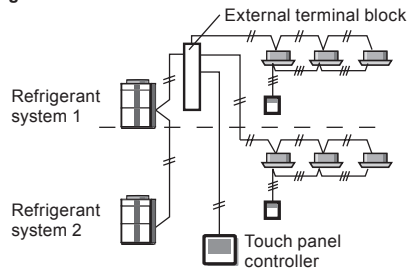
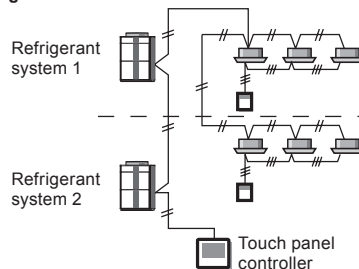

Fig. 3



5. 5. Installation method

- Install the switch box in advance to the wall to which the touch panel controller is to be installed.
- (1) Installation procedure
 - ① Verify that the power supply cable and transmission cable are wired to the switch box.
 - ② Peel the cable covering.
 - ③ Decide the path the power supply cable and transmission cable are to follow up to the terminals of the touch panel controller.
 - ④ After passing the power supply cable and transmission cable through the specified holes of the installation plate, fix the installation plate to the switch box using screws. Adjust the tilt of the installation plate by installing the accessory washers.
 - ⑤ In addition, pass the power supply cable and transmission cable through the wiring hole of the rear cover and fix the rear cover using the tapping screws (M4 x 8mm, 2 screws) supplied with the installation plate.
 - ⑥ Next, fix the rear cover to the wall using the 2 accessory screws (M4 x 20mm) and accessory washers.
 - ⑦ Fix the cables at 2 places by binders.
 - ⑧ Provide a surplus of 5mm or more from the end of the covering of the cable and fix the part which is fixed by the binders.
 - ⑨ Fix the power supply cable and transmission cable to their respective terminal so that there is no mistake.

Tightening torque	
Power supply cable	1.2 to 1.8 N • m (10.7 to 15.9 lbf • in)
Transmission cable	0.8 to 1.2 N • m (7.1 to 10.6 lbf • in)

- ⑩ Insert the connector of the connection cable.
- ⑪ Close the front cover and rear cover. Align the claw of the bottom of the front cover and fit the top to the rear cover.
- ⑫ Tighten the 2 screws at the side of the main unit.

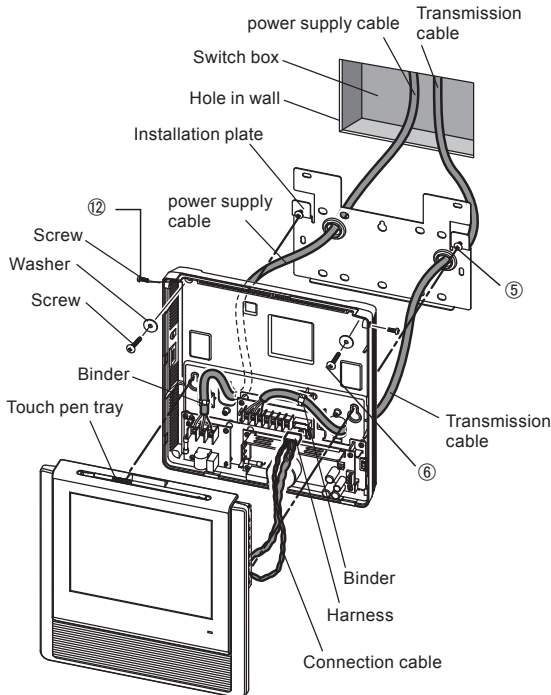

(2) Installation of touch pen

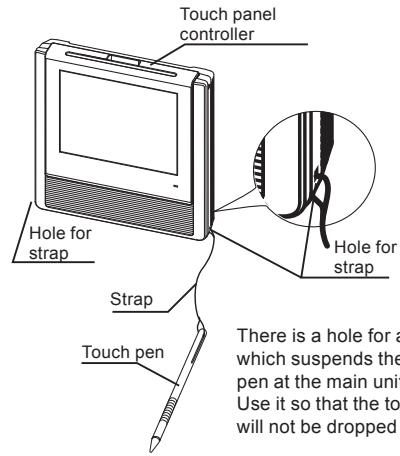

There is a hole for a strap which suspends the touch pen at the main unit. Use it so that the touch pen will not be dropped or lost.

* There are holes for a strap at both sides of the main unit. Install at the easiest hole to use.

6. TURNING ON THE POWER

⚠ CAUTION

Check that the power supply voltage is within the specified range. If a power supply voltage outside the specification is input, it will cause trouble.

Recheck the wiring. Incorrect wiring will cause trouble.

After installation work is completed, check the following contents:

- ① Is touch panel controller power supply cable and transmission cable wiring work complete?
- ② Does the power supply match the rating of the touch panel controller?
- ③ Turn on the touch panel controller main unit power. Since there is no power switch at the main unit, turn on the power by means of the power distribution panel.
- ④ If the following installer setting screen is displayed at the screen of the touch controller panel, installation work is complete.

For setting and operating of the touch panel controller, refer to the separate operating manual.

* Since there is some kind of a problem when the installer setting screen does not appear, recheck the work contents.

