

UTY-VGGXZ1

INSTALLATION MANUAL

NETWORK CONVERTOR
For authorized service personnel only.

安装说明书

网络转换器
只适用于专业维修人员

MANUEL D'INSTALLATION

ADAPTATEUR RESEAU
Uniquement réservé aux techniciens agréés.

MANUAL DE INSTALACIÓN

CONVERTIDOR DE RED
Sólo para personal de mantenimiento autorizado.

MANUAL DE INSTALAÇÃO

CONVERSOR DE REDE
Apenas para técnicos de assistência autorizados.

English

中文

Français

Español

Português

INSTALLATION MANUAL

PART NO. 9374707096
NETWORK CONVERTOR

Contents

1. SAFETY PRECAUTIONS	1
2. MAIN UNIT AND ACCESSORIES	2
3. ELECTRICAL REQUIREMENT	2
4. SELECTING AN INSTALLATION LOCATION	2
4. 1. Dimensions	2
5. USING THE NETWORK CONVERTOR	3
■ SETTING METHOD WHEN CONNECTING A GROUP REMOTE CONTROLLER	
6. WIRING	3
6. 1. Wiring method	3
7. INSTALLING THE NETWORK CONVERTOR	4
7. 1. Connecting the power supply cable	4
7. 2. Connecting the transmission cables	5
8. CIRCUIT BOARD SETTING	5
9. TURNING ON THE POWER	6
10. ERROR CODE DISPLAY	6
■ SETTING METHOD WHEN CONNECTING A SINGLE SPLIT TYPE INDOOR UNIT	
11. WIRING	6
11. 1. Wiring method	7
12. INSTALLING THE NETWORK CONVERTOR	8
12. 1. Connecting the power supply cable	8
12. 2. Connecting the transmission cables	9
12. 3. Connection of remote controller cable	9
13. CIRCUIT BOARD SETTING	10
14. TURNING ON THE POWER	11
15. SETTING CHECK MODE	12
16. ERROR CODE DISPLAY	12

1. SAFETY PRECAUTIONS

- The "SAFETY PRECAUTIONS" indicated in this manual contain important information pertaining to your safety. Be sure to observe them.
- Request the user to keep this manual on hand for future use, such as for relocating or repairing the unit.

WARNING

This mark indicates procedures which, if improperly performed, might lead to the death or serious injury of the user.

Perform electrical work by an authorized service personnel in accordance with this manual and the electrical wiring regulations or implementation regulations of the country. Also do not install this unit by yourself. Improper electric work will cause electric shock or a fire.

Perform installation work in accordance with this manual. Request an authorized service personnel to perform installation work. Do not install this unit by yourself. Improper installation will cause injury, electric shock, fire, etc.

In the event of a malfunction (burning smell, etc.), immediately stop operation, turn off the electrical breaker, and consult authorized service personnel.

Install a leakage circuit breaker to power supply cable in accordance with the related laws and regulations and electric company standards.

Use a power source exclusively for this unit. Never share the power source with other electrical equipment. Doing so will cause fire and electric shock.

Do not install the unit in the following areas:

- Do not install the unit near a source of heat, steam, or flammable gas.
- Area filled with mineral oil or containing a large amount of splashed oil or steam, such as a kitchen. It will deteriorate plastic parts, causing the parts to fail or the unit to leak water.
- Area that generates substances that adversely affect the equipment, such as sulfuric gas, chlorine gas, acid, or alkali. It will cause the copper pipes and brazed joints to corrode, which can cause refrigerant leakage.
- Area containing equipment that generates electromagnetic interference. It will cause the control system to malfunction, preventing the unit from operating normally.
- Area that can cause combustible gas to leak, contains suspended carbon fibers or flammable dust, or volatile inflammables such as paint thinner or gasoline. If gas leaks and settles around the unit, it can cause a fire.
- Do not use the unit for special purposes, such as storing food, raising animals, growing plants, or preserving precision devices or art objects. It can degrade the quality of the preserved or stored objects.
- Install the unit in a well-ventilated place avoiding rains and direct sunlight.

Do not operate this unit when your hands are wet. Touching the unit with wet hands will cause an electric shock.

If children may approach the unit, take preventive measures so that they cannot reach the unit.

CAUTION

This mark indicates procedures which, if improperly performed, might possibly result in personal harm to the user or damage to property.

Pay abundant care when transporting this unit because it is a precision device. Improper transportation will cause trouble.

Do not touch the switches with sharp objects. Doing so will cause injury, trouble, or electric shock.

Do not expose this unit directly to water. Doing so will cause trouble, electric shock, or heating.





Do not set vessels containing a liquid on this unit. Doing so will cause heating, fire, or electric shock.

Dispose of the packing materials safely. Tear and dispose of the plastic packing bags so that children cannot play with them. There is the danger of suffocation if children play with the original plastic bags.

Do not insert articles into the slit parts of this unit. Doing so will cause trouble, heating, or electric shock.

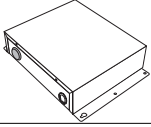
2. MAIN UNIT AND ACCESSORIES

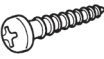
The following installation parts are supplied. Use them as required.

Name and Shape	Q'ty	Application
 Network converter	1	Main unit
 Installation manual	1	This manual
 Binder	4	For mounting the power supply cable, remote controller cable and transmission cable.
 Screw (M4 x 20 mm)	4	For mounting the network converter.
 Dust proof bushing	1	For connecting the power supply cable. (Except in U.S.A. and Canada)

3. ELECTRICAL REQUIREMENT

Use	Size	Wire type	Remarks
Power supply cable	Maximum	1.25 mm ² (16AWG)	Type 60245 IEC 57 or equivalent
	Minimum	0.5 mm ² (20AWG)	
Transmission cable	0.33 mm ² (22AWG)	22AWG LEV-EL4 (NEMA) nonpolar 2 core, twisted pair solid core Shielded	LONWORKS® compatible cable
Remote controller cable	0.33 mm ² (22AWG)	Polar 3core, Twisted pair	Use shield cable
Fuse capacity	3 A		

4. SELECTING AN INSTALLATION LOCATION

4.1. Dimensions

The network converter is comprised of a body and cover.
Unit : mm (in.)

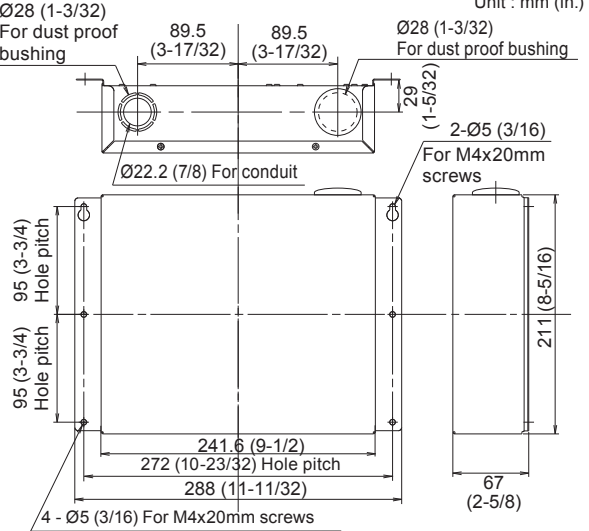

Power supply	1Ø AC208–240V 50/60 Hz
Power consumption (W)	6.5
Temperature °C (°F)	Operating 0–46 (32–114)
	Packaged -10–60 (14–140)
Humidity (%)	Packaged 0–95 (RH); No condensation
Dimensions H x W x D mm(in.)	67 × 288 × 211 (2-5/8 × 11-11/32 × 8-5/16)
Weight g (oz.)	1500 (53)

5. USING THE NETWORK CONVERTOR

The network convertor has 2 uses. Since the setting method is different depending on how the network convertor is used, refer to the following information to make the settings.

(1) To connect a group remote controller



See items:
6. WIRING
7. INSTALLING THE NETWORK CONVERTOR
8. CIRCUIT BOARD SETTING
9. TURNING ON THE POWER
10. ERROR CODE DISPLAY

(2) To connect a single split type indoor unit



See items:
11. WIRING
12. INSTALLING THE NETWORK CONVERTOR
13. CIRCUIT BOARD SETTING
14. TURNING ON THE POWER
15. SETTING CHECK MODE
16. ERROR CODE DISPLAY

SETTING METHOD WHEN CONNECTING A GROUP REMOTE CONTROLLER

6. WIRING

⚠ WARNING

Before starting installation work, turn off the power of this unit and the connection destination. Do not turn on the power again until installation is completed. Otherwise, it will cause electric shock or fire.

Use the accessories or specified power supply cable and transmission cables. Do not modify power supply cable and transmission cables other than those specified, do not use extension cables, and do not use independent branch wiring. Overcurrent may cause electric shock or fire.

Install the transmission cables securely to the terminal block. Confirm that external force is not applied to the cable. Use transmission cables made of the specified cable. If intermediate connection or insertion fixing are imperfect, it will cause electric shock, fire, etc.

When connecting the power supply cable and transmission cable, route the cables so that the cover of this unit is securely fixed. If the cover is imperfectly fixed, it may cause fire or overheating of the terminals.

Perform earth (ground) work positively. Do not connect the earth (ground) cable to a telephone cable, water pipe, or conductor rod.

Always fasten the outside covering of the transmission cables with the cable clamp. (If the insulator is chafed, electric leakage may occur.)

Perform all wiring works so that the user does not touch the wiring. Doing so will cause injury or electric shock.

If any cable is damaged, do not repair or modify it yourself. Improper work will cause electric shock or fire.

⚠ CAUTION

Do not bind the remote controller cable and the transmission cable together with or parallel to the power supply cable of the indoor and outdoor units. It may cause erroneous operation.

When performing wiring work, be careful not to damage the cable or injure yourself. Also, connect the connectors securely. Loose connectors will cause trouble, heating, fire, or electric shock.

Install the indoor and outdoor units, power supply cable, transmission cable and remote controller cable 1 m (40 in.) away from television and radio to avoid distorted images and noise. Otherwise, a malfunction could result.

Perform wiring so that water does not enter this unit along the external wiring. Always install a trap to the wiring or take other countermeasures. Otherwise it will cause trouble or electric shock or fire.

Confirm the name of each unit and name of each terminal block of the unit and connect the wiring in accordance with the directions given in the manual so that there is no incorrect wiring. Incorrect wiring will damage the electric parts and cause smoke and fire.

When installing the transmission cables near a source of electromagnetic waves, use shielded cable. Otherwise, a breakdown or malfunction could result.

The terminal screws and earth (ground) screws have different shapes. Be sure to install the screws in the correct locations. If the screws are installed in the wrong locations, the circuit board could be damaged.

6.1. Wiring method

Number of connected network convertors

- Up to a total of 16 network convertors (UTY-VGGXZ1) and touch panel controllers, etc. can be connected in the VRF system.
- Up to 4 group remote controllers can be connected to 1 network convertor (UTY-VGGXZ1).
- Total remote controller cable length when connected to 1 convertor \leq 100 m (328 ft.)

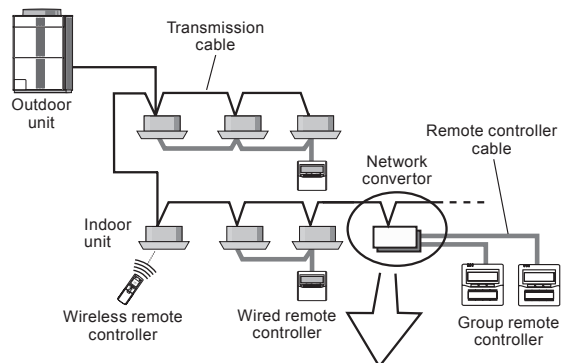

[Example of connecting group remote controllers in a parallel arrangement]

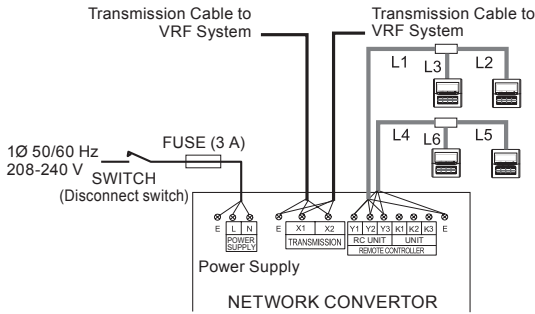

$$L1 + L2 + L3 + L4 + L5 + L6 \leq 100 \text{ m (328 ft.)}$$

or

[Example of connecting group remote controllers in series]

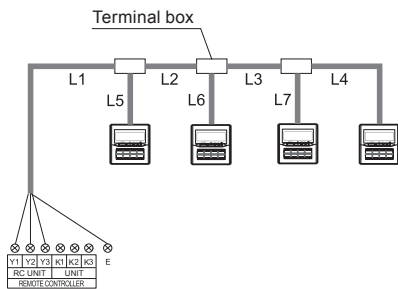

$$L1 + L2 + L3 + L4 + L5 + L6 + L7 \leq 100 \text{ m (328 ft.)}$$

Note:

- Use of a terminal box is recommended when a junction is made in the wiring.
- Do not bind the power cable, remote controller cable and transmission cable to avoid an erroneous operation.
- Use ground cable to ground the network converter.
- Use shield cable for transmission cable and remote controller cable. The shield metal should be grounded.
- Install the disconnect switch to the easily accessible location.
- Install the fuse (3A) to the L line of power supply cable.

7. INSTALLING THE NETWORK CONVERTOR

⚠ WARNING

Always use the accessories and specified installation work parts. Check the state of the installation parts. Not using the specified parts will cause units to fall off, water leakage, electric shock, fire, etc.

Install at a place that can withstand the weight of the unit and install positively so that the unit will not topple or fall.

When installing this unit, make sure that there are no children nearby.
Otherwise, injury or electric shock could result.

Install a circuit breaker.
Otherwise, electric shock or fire could result.

⚠ CAUTION

Do not set the DIP switch or rotary switch of this unit except as specified in this installation manual or the instruction manual supplied with the air conditioner. Setting the switches other than specified will cause an accident or trouble.

Use an insulated screwdriver to set the DIP switches.

Before opening the cover of this unit, completely discharge static electricity charged on your body. Otherwise, failure or malfunction could result.

Do not touch the circuit board and circuit board parts directly with your hands.
Otherwise, injury or electric shock could result.

Tightening the mounting screws too tight will damage the body of this unit.

Be careful so that the cover does not fall after the cover screws are removed.
Otherwise, injury could result.

7.1. Connecting the power supply cable

for U.S.A. and Canada

- (1) Remove the 4 screws (M4 × 6 mm), and then remove the cover.
- (2) Install the conduit.
- (3) Fix the conduit with lock nut.
- (4) Pass the power supply cable through the conduit.
- (5) Connect the power supply cable to their respective terminal block and the earth (ground).
- (6) Securely tighten the binder and then confirm that the cable will not come out.

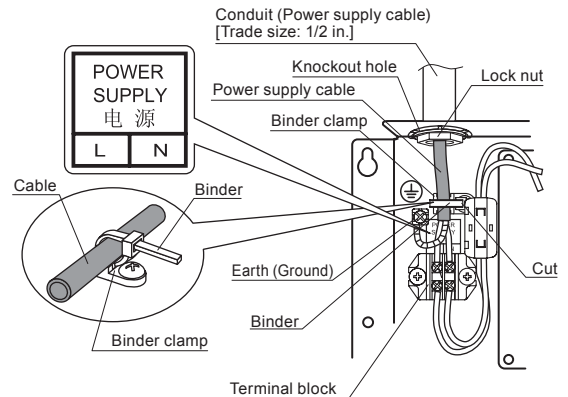

for Others

- (1) Remove the 4 screws (M4 × 6 mm), and then remove the cover.
- (2) Open the knockout hole, and then install dust proof bushing. If small animals such as insects and dust enter this unit, a short circuit may be caused.
- (3) Make a hole in the center of the dust proof bushing with the Phillips head screwdriver.
- (4) Pass the power supply cable through the hole of dust proof bushing and pull it into the network converter.
- (5) Connect the power supply cable to their respective terminal block and the earth (ground).
- (6) Securely tighten the binder and then confirm that the cable will not come out.

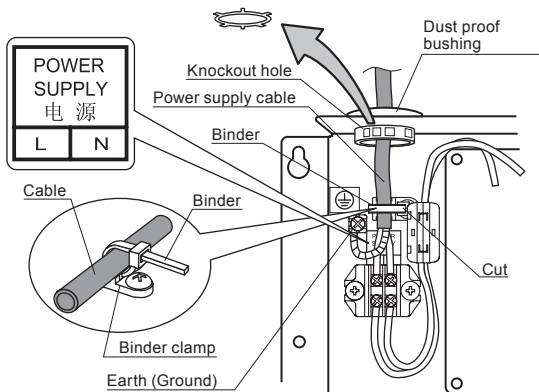

Tightening torque for installing cables to terminal block

0.8 to 1.2 N · m (7.1 to 10.6 lbf-in)

7.2. Connecting the transmission cables

- (1) Turn the power off.
- (2) Make a hole in the center of the dust proof bushing with the Phillips head screwdriver.
- (3) Pass the transmission cable and remote controller cable through the hole of dust proof bushing and pull it into the network converter.
- (4) Connect the transmission cable and remote controller cable to their respective terminal block properly.
- (5) Securely tighten the binders and then confirm that the cable will not come out.
- (6) Once the wiring of the cables has been completed, mount the cover to the network converter. Use the screws (M4 × 6 mm) to mount the cover.
- (7) Use the 4 screws (M4 × 20 mm) provided to mount the network converter to the behind ceiling, wall, floor or other suitable location.

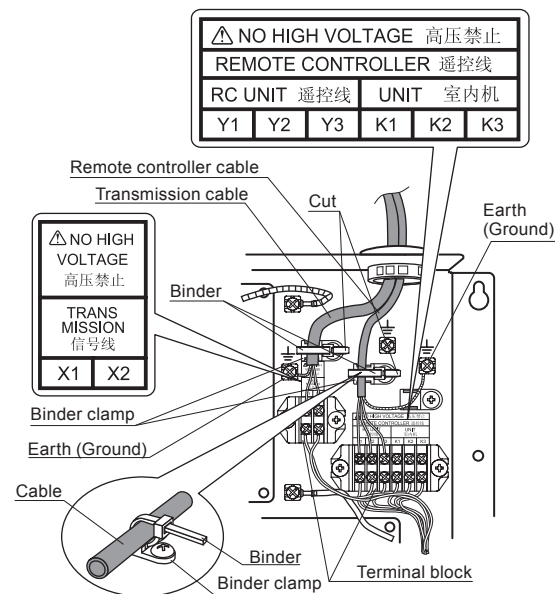

Tightening torque for installing cables to terminal block

0.8 to 1.2 N · m (7.1 to 10.6 lbf-in)

8. CIRCUIT BOARD SETTING

Set network converter rotary switch SW110, SW111 and Dip switch SW103, SW107, SW108, SW109.

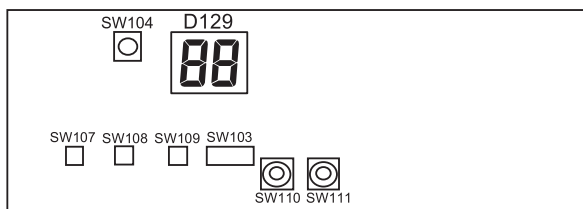

[Rotary switch-SW110, SW111] Converter address settings

Set the converter address in accordance with the following table for each network converter.

- * Be sure to set the converter address different from the touch panel controller address (refer to the setting manual for the touch panel controller).
- * Each converter address can be selected freely but the same address cannot be used more than once.
- * Example: When SW110 is set to "1" and SW111 is set to "4", the converter address will be "14".

Converter address		0	1	2	3	4	5	6	7
Rotary switch	SW110	★0	0	0	0	0	0	0	0
	SW111	★0	1	2	3	4	5	6	7

Converter address		8	9	10	11	12	13	14	15
Rotary switch	SW110	0	0	1	1	1	1	1	1
	SW111	8	9	0	1	2	3	4	5

(★: Factory setting)

[DIP switch - SW103] Group remote controller converter setting

Set the switches as follows.

DIP switch - SW103							
1	2	3	4	5	6	7	8
Fixed at ON	Fixed at ON	Fixed at ON	Fixed at ON	Fixed at OFF	Fixed at OFF	Fixed at OFF	Fixed at OFF

[DIP switch - SW107, SW108, SW109]

Set the switches as follows.

DIP switch-SW107		DIP switch-SW108		DIP switch-SW109	
1	2	1	2	1	2
Fixed at OFF	Fixed at OFF	Fixed at OFF	Fixed at OFF	Fixed at OFF	Fixed at OFF

9. TURNING ON THE POWER

⚠ CAUTION

Check that the power supply voltage is within the specified range. If the power supply voltage outside the specification is input, it will cause trouble.

- (1) Check the network convertor wiring and switch settings on the circuit board.
- (2) Check the wiring and switch settings for the VRF system. For the wiring and switch settings method, refer to the installation instruction sheet of each unit.
- (3) Turn on the power for the VRF system.
- (4) Turn on the power for the network convertor.

- The network convertor is initialized for a period of approximately ten seconds after turned on the power.







 is displayed on D129 during this period.

- After initial setting completely the operation mode will be started.  is displayed on D129.

* Network convertor does not operate during initialization. Do not attempt control from the units.

* An error code will appear on D129 in the event of a malfunction.

10. ERROR CODE DISPLAY

Error code	Contents
	No error (operation mode)
	Initial setting
	Main PCB error
	Remote controller communication error
	Network communication error
	EEPROM error
	Address setting error

11. SETTING METHOD WHEN CONNECTING A SINGLE SPLIT TYPE INDOOR UNIT

11. WIRING

⚠ WARNING

Before starting installation work, turn off the power of this unit and the connection destination. Do not turn on the power again until installation is completed. Otherwise, it will cause electric shock or fire.

Use the accessories or specified power supply cable and transmission cables. Do not modify power supply cable and transmission cables other than those specified, do not use extension cables, and do not use independent branch wiring. Overcurrent may cause electric shock or fire.

Install the transmission cables securely to the terminal block. Confirm that external force is not applied to the cable. Use transmission cables made of the specified cable. If intermediate connection or insertion fixing are imperfect, it will cause electric shock, fire, etc.

When connecting the power supply cable and transmission cable, route the cables so that the cover of this unit is securely fixed. If the cover is imperfectly fixed, it may cause fire or overheating of the terminals.

Perform earth (ground) work positively. Do not connect the earth (ground) cable to a telephone cable, water pipe, or conductor rod.

Always fasten the outside covering of the transmission cables with the cable clamp. (If the insulator is chafed, electric leakage may occur.)

Perform all wiring works so that the user does not touch the wiring. Doing so will cause injury or electric shock.

If any cable is damaged, do not repair or modify it yourself. Improper work will cause electric shock or fire.

⚠ CAUTION

Do not bind the remote controller cable and the transmission cable together with or parallel to the power supply cable of the indoor and outdoor units. It may cause erroneous operation.

When performing wiring work, be careful not to damage the cable or injure yourself. Also, connect the connectors securely. Loose connectors will cause trouble, heating, fire, or electric shock.

Install the indoor and outdoor units, power supply cable, transmission cable and remote controller cable 1 m (40 in.) away from television and radio to avoid distorted images and noise. Otherwise, a malfunction could result.

Perform wiring so that water does not enter this unit along the external wiring. Always install a trap to the wiring or take other countermeasures. Otherwise it will cause trouble or electric shock or fire.

Confirm the name of each unit and name of each terminal block of the unit and connect the wiring in accordance with the directions given in the manual so that there is no incorrect wiring. Incorrect wiring will damage the electric parts and cause smoke and fire.

When installing the transmission cables near a source of electromagnetic waves, use shielded cable. Otherwise, a breakdown or malfunction could result.

The terminal screws and earth (ground) screws have different shapes. Be sure to install the screws in the correct locations. If the screws are installed in the wrong locations, the circuit board could be damaged.

11. 1. Wiring method

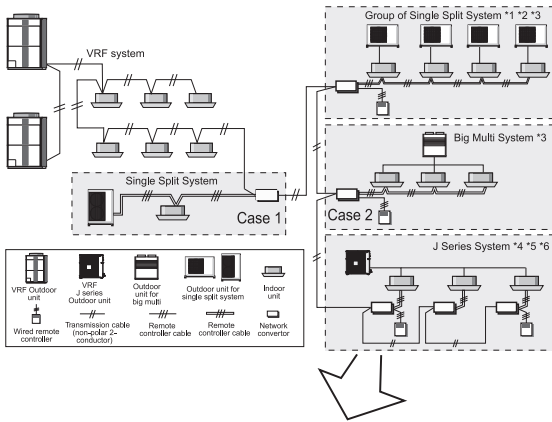

[Example of connecting single split type indoor unit in a parallel arrangement]

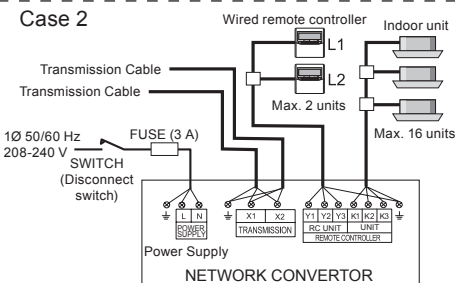
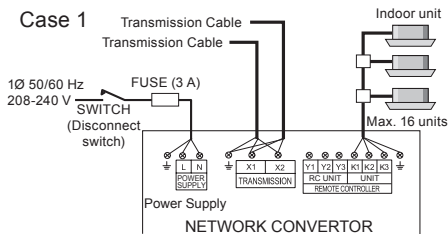

Note:

- Install the disconnect switch to the easily accessible location.
- Install the fuse (3A) to the L line of power supply cable.

- *1. Up to 16 indoor units may be controlled with a single network converter, however multiple indoor units connected to the network converter are generally required to have the same operation setting.
- *2. Always use indoor units with the same RC model or the same system type when connecting multiple indoor units. Refer to "[DIP switch - SW103 <1, 2, 3, 4>] RC model or system type setting" in "13 CIRCUIT BOARD SETTING" for information about RC models.

- *3. Connect a single big multi system to a single network converter. 2 units or more of big multi systems cannot be connected. Big multi system and single split system can also be connected simultaneously.

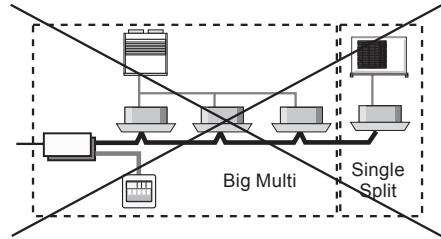

- *4. Network converter is necessary for each indoor unit.
- *5. For using J series heat pump system, "AUTO" and "FAN" mode should not be used.
- *6. When connecting the J-series heat pump model, the set operation conditions will be displayed on the control unit. Therefore, the indoor unit may enter the operation standby condition as described below.

Ex. 1) If FAN setting is selected from the control unit, the LED on the indoor unit will flash and the unit will enter the operation standby condition. Select another operation mode to clear the standby condition.

Ex. 2) If an operation mode that is different from a currently operating indoor unit is selected from the control unit, the LED on the indoor unit will flash and the unit will enter the operation standby condition. Or, if operation becomes possible, such as by stopping the other indoor unit, the standby condition will be cleared and the indoor unit will automatically start operating with the selected mode.

Number of connected network converters

- Up to 100 network converters may be connected in the VRF system.
- * A single network converter is considered as a single refrigerant system, irrespective of the number of connected single split type.

Compatible indoor units

J-series		○
	Wireless RC model	×
Big multi	Simultaneous model	○
	Individual model	○
Single split type		○
	Wired RC model	○
	Wireless RC model	×
Window type		×

Connectable types of indoor unit and remote controller

● Connectable remote controllers

3 types of wired remote controller shown in the table below can be connected to this unit.

Model name	RC number
UTB-★UB	AR-3TA★★
UTB-★UD	AR-6TC★★
UTB-RNN★M	AR-WAE★★

(★ arbitrary character)

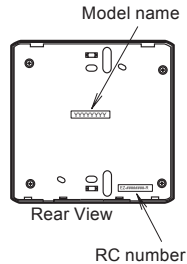

● Connectable indoor units

Indoor units that accept following wired remote controllers (accessories or optional parts) are connectable with this unit.

RC number
AR-3TA★★, AR-6TC★★, AR-WAE★★
EZ-099DHSE-R, EZ-000DHSE-R, EZ-0001HSE-R, EZ-000GHSE-R, EZ-00004HSE-R, EZ-00005HSE-R, EZ-0015HSE-R, EZ-0019HSE-R, EZ-099DHSEFR, EZ-0001HSEFR, EZ-000DHSEFR, EZ-000GHSEFR, EZ-0015HSEFR
EZ-0994HSE-R, EZ-000EHSE-R, EZ-0994HSEFR, EZ-099CWSE-R, EZ-000AWSE-R, EZ-0001WSE-R, EZ-000FWSE-R, EZ-0012WSE-R, EZ-099CWSEFR, EZ-0001WSEFR, EZ-000AWSEFR
EZ-09906WSE-R, EZ-000BWSE-R, EZ-09906WSEFR

EZ type remote controllers cannot control indoor units via this unit. When you want to operate indoor units directly by remote controller, the optional remote controller must be purchased.

12. INSTALLING THE NETWORK CONVERTOR

⚠ WARNING

Always use the accessories and specified installation work parts. Check the state of the installation parts. Not using the specified parts will cause units to fall off, water leakage, electric shock, fire, etc.

Install at a place that can withstand the weight of the unit and install positively so that the unit will not topple or fall.

When installing this unit, make sure that there are no children nearby.
Otherwise, injury or electric shock could result.

Install a circuit breaker.
Otherwise, electric shock or fire could result.

⚠ CAUTION

Do not set the DIP switch or rotary switch of this unit except as specified in this installation manual or the instruction manual supplied with the air conditioner. Setting the switches other than specified will cause an accident or trouble.

Use an insulated screwdriver to set the DIP switches.

Before opening the cover of this unit, completely discharge static electricity charged on your body. Otherwise, failure or malfunction could result.

Do not touch the circuit board and circuit board parts directly with your hands.

Otherwise, injury or electric shock could result.

Tightening the mounting screws too tight will damage the body of this unit.

Be careful so that the cover does not fall after the cover screws are removed.
Otherwise, injury could result.

12. 1. Connecting the power supply cable

for U.S.A. and Canada

- Remove the 4 screws (M4 × 6 mm), and then remove the cover.
- Install the conduit.
- Fix the conduit with lock nut.
- Pass the power supply cable through the conduit.
- Connect the power supply cable to their respective terminal block and the earth (ground).
- Securely tighten the binder and then confirm that the cable will not come out.

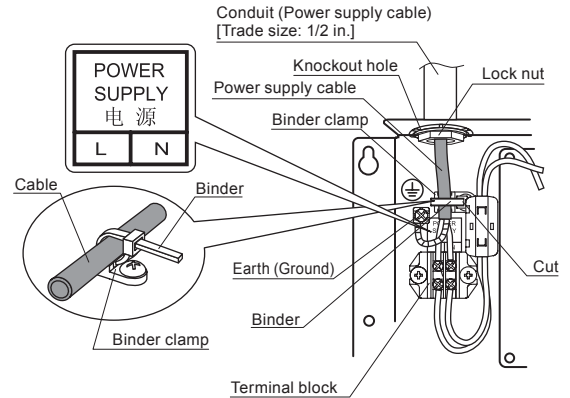

for Others

- Remove the 4 screws (M4 × 6 mm), and then remove the cover.
- Open the knockout hole, and then install dust proof bushing. If small animals such as insects and dust enter this unit, a short circuit may be caused.
- Make a hole in the center of the dust proof bushing with the Phillips head screwdriver.
- Pass the power supply cable through the hole of dust proof bushing and pull it into the network convertor.
- Connect the power supply cable to their respective terminal block and the earth (ground).
- Securely tighten the binder and then confirm that the cable will not come out.

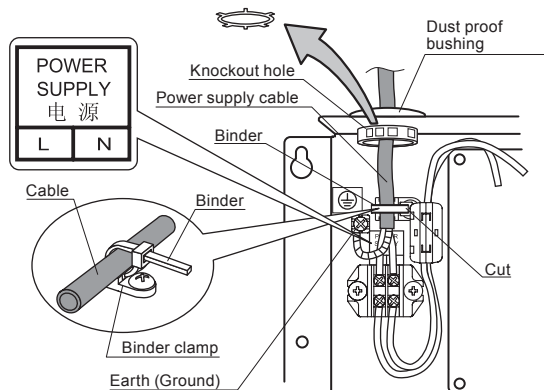

Tightening torque for installing cables to terminal block

0.8 to 1.2 N · m (7.1 to 10.6 lbf-in)

12.2. Connecting the transmission cables

- Turn the power off.
- Make a hole in the center of the dust proof bushing with the Phillips head screwdriver.
- Pass the transmission cables and remote controller cable through the hole of dust proof bushing and pull it into the network converter.
- Connect the transmission cables and remote controller cable to their respective terminal block properly.
- Securely tighten the binders and then confirm that the cable will not come out.
- Once the wiring of the cables has been completed, mount the cover to the network converter. Use the screws (M4 × 6 mm) to mount the cover.
- Use the 4 screws (M4 × 20 mm) provided to mount the network converter to the behind ceiling, wall, floor or other suitable location.

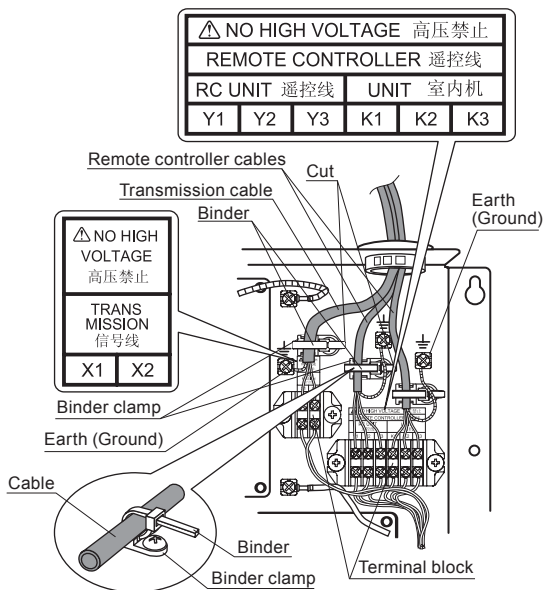

Tightening torque for installing cables to terminal block

0.8 to 1.2 N · m (7.1 to 10.6 lbf-in)

12.3. Connection of remote controller cable

CAUTION

When connecting the remote controller cable to the indoor unit, do not connect it to the outdoor unit or the power terminal block. It may cause a failure.

When connecting Indoor unit and Network converter with the Remote controller cable, the following items should be considered.

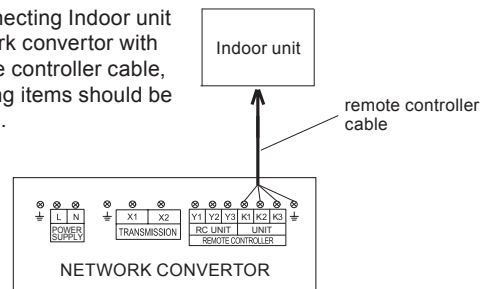

There are 2 methods to connect the remote controller cable to the indoor unit. One is the connection using contained connecting cable, and the other is the connection the remote controller cable is connected to the exclusive terminal block of the indoor unit.

Exclusive terminal block for remote controller connection method is different depending on each model. Modify the remote controller cable as per below description and connect it.

(For the details, refer to the installation manual of the indoor unit to be used.)

(1) WHEN CONNECTING TO THE CONNECTOR

Connect the remote controller cable to the connecting cable, and insert it to the connector.

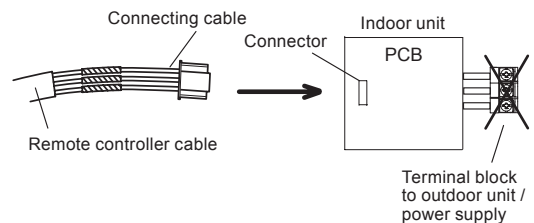

Modify the cable as per below methods.

- Use a tool to cut off the terminal on the end of the remote controller cable, and then remove the insulation from the cut end of the cable as shown in Fig. 1.
- Connect the remote controller cable and connecting cable as shown in Fig. 2.
- Be sure to insulate the connection between the cables.

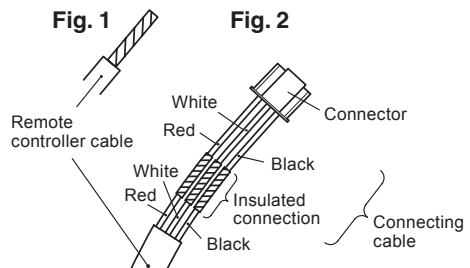

(2) WHEN CONNECTING TO THE EXCLUSIVE TERMINAL BLOCK

Connect the end of remote controller cable directly to the exclusive terminal block.

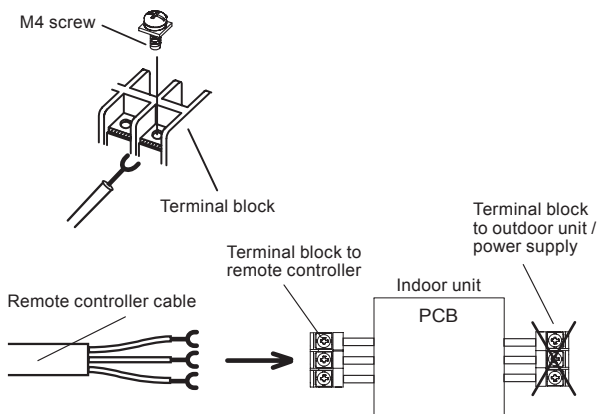

* It may be failed if it is connected to the outdoor unit or the terminal block for power supply.

13. CIRCUIT BOARD SETTING

Set network convertor rotary switch SW110, SW111 and Dip switch SW103, SW107, SW108, SW109.

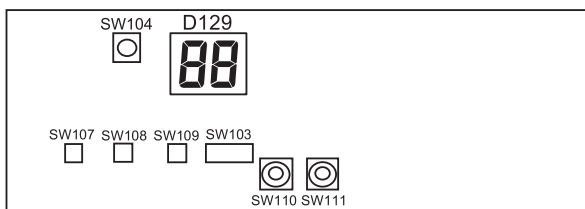

(1) [Rotary switch-SW110, SW111] set the refrigerant circuit address

A single network convertor is considered as a single refrigerant system, irrespective of the number of connected single models.

In the case of multiple refrigerant system, set SW110 and SW111 as shown in the following table for each Network convertor.

Example: When SW110 is set to "2" and SW111 is set to "0", the refrigerant circuit address will be "20".

Refrigerant circuit address	Rotary Switch Setting		Refrigerant circuit address	Rotary Switch Setting	
	SW110	SW111		SW110	SW111
0	★0	★0	16	1	6
1	0	1	17	1	7
2	0	2	18	1	8
3	0	3	19	1	9
4	0	4	20	2	0
5	0	5	21	2	1
6	0	6	22	2	2
7	0	7	23	2	3
8	0	8	24	2	4
9	0	9	25	2	5
10	1	0	26	2	6
11	1	1	27	2	7
12	1	2	⋮	⋮	⋮
13	1	3	⋮	⋮	⋮
14	1	4	98	9	8
15	1	5	99	9	9

(★: Factory setting)

(2) [DIP switch-SW103 <1, 2, 3, 4>] Signal conversion type setting

PATTERN1 — When indoor unit packed together with the wired remote controllers shown in the table below is connected

Check the RC number of the wired remote controller packed together with the indoor unit. Then perform DIP switch setting applicable to that RC number.

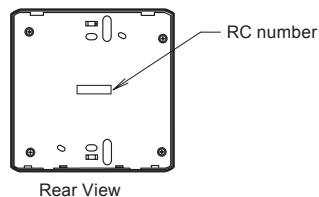

RC number	DIP switch-SW103			
	1	2	3	4
EZ-099DHSE-R, EZ-000DHSE-R, EZ-0001HSE-R, EZ-000GHSE-R, EZ-00004HSE-R, EZ-00005HSE-R, EZ-0015HSE-R, EZ-0019HSE-R, EZ-099DHSEFR, EZ-0001HSEFR, EZ-000DHSEFR, EZ-000GHSEFR, EZ-0015HSEFR	OFF	OFF	OFF	OFF
EZ-0994HSE-R, EZ-000EHSE-R, EZ-0994HSEFR	OFF	OFF	OFF	ON
EZ-099CWSE-R, EZ-000AWSE-R, EZ-0001WSE-R, EZ-000FWSE-R, EZ-0012WSE-R, EZ-099CWSEFR, EZ-0001WSEFR, EZ-000AWSEFR	ON	OFF	OFF	OFF
EZ-09906WSE-R, EZ-000BWSE-R, EZ-09906WSEFR	ON	OFF	OFF	ON

PATTERN2 — When indoor units other than PATTERN1 is connected

Temporary setting is performed in accordance with the table below. After temporary setting was performed, perform "15. SETTING CHECK MODE".

RC number	DIP switch-SW103			
	1	2	3	4
Heat pump model	OFF	OFF	ON	ON
cool only	ON	OFF	ON	ON

* Always perform the Setting check mode after DIP switch setting.

(3) [DIP switch-SW103 <5, 6, 7, 8>] Setting the number of connected indoor units

Set the number of connected indoor units as shown in the following table.

Number of the connected indoor unit	DIP switch-SW103			
	5	6	7	8
1	★OFF	★OFF	★OFF	★OFF
2	OFF	OFF	OFF	ON
3	OFF	OFF	ON	OFF
4	OFF	OFF	ON	ON
5	OFF	ON	OFF	OFF
6	OFF	ON	OFF	ON
7	OFF	ON	ON	OFF
8	OFF	ON	ON	ON
9	ON	OFF	OFF	OFF
10	ON	OFF	OFF	ON
11	ON	OFF	ON	OFF
12	ON	OFF	ON	ON
13	ON	ON	OFF	OFF
14	ON	ON	OFF	ON
15	ON	ON	ON	OFF
16	ON	ON	ON	ON

(★: Factory setting)

(4) [DIP switch-SW107<1,2>,DIP switch-SW108<1,2>,DIP switch-SW109<1,2>] Function setting

Set functions as shown in the following table.

	NO.	Switch state		Detail
		OFF	ON	
DIP switch-SW107	1	★Fixed at OFF	—	Not used
	2	★Invalidity	Validity	Wired RC validity / invalidity setting
DIP switch-SW108	1	★Fixed at OFF	—	Not used
	2	★Fixed at OFF	—	Not used
DIP switch-SW109	1	★Invalidity	Validity	Auto changeover validity / invalidity setting Set to OFF when connecting the J-series heat pump model * Set to OFF when a remote sensor is not used (duct model).
	2	★Invalidity	Validity	Auto restart validity / invalidity setting

(★: Factory setting)

14. TURNING ON THE POWER

⚠ CAUTION

Check that the power supply voltage is within the specified range. If the power supply voltage outside the specification is input, it will cause trouble.

- (1) Check the network convertor wiring and switch settings on the circuit board.
- (2) Check the wiring and switch settings for the VRF system and big multi system or single model. For the wiring and switch settings method, refer to the installation instruction sheet of each unit.
- (3) Turn on the power for the VRF system and big multi system or single model.
- (4) Turn on the power for the network convertor.

- The network convertor is initialized for a period of approximately ten seconds after turned on the power.

 is displayed on D129 during this period.

- After initial setting completely the operation mode will be started.  is displayed on D129.

* Network convertor does not operate during initialization. Do not attempt control from the units.

* An error code will appear on D129 in the event of a malfunction.

15. SETTING CHECK MODE

⚠ CAUTION

Perform the setting check mode after stopping the indoor unit operation. Since the indoor unit cannot be stopped if the setting check mode is performed while the indoor unit is operating, it may cause indoor unit trouble.

- (1) Perform the following installation and setting checks. If the setting is incorrect, the setting check mode will not operate properly.
 - Network convertor wiring
 - DIP switch setting
 - Indoor unit address setting
(Indoor unit addresses must be sequential. There must not be any duplicate settings.)
- (2) Turn on the power of the connected indoor units. At this time, place the operation into the stopped state.
- (3) Turn on the power of the network convertor. Refer to "14. TURNING ON THE POWER" for the operation procedure.
 - * When not ended normally, reset the DIP switch.
- (4) Press SW104 until **r1** is displayed. (Several seconds) The setting check mode starts.
- (5) When **r0** is displayed, the setting check mode ends. → Turn on the power of each indoor unit and this unit again. If the power is not turned on, operation will not be normal even if returned to normal operation. If **r1**, **r2**, **r3**, or **r9** is displayed, perform the operation in accordance with the following table.

code	Countermeasure method																			
r1	Reset the DIP switch.																			
	<table border="1"> <thead> <tr> <th rowspan="2">RC number</th> <th colspan="4">DIP switch-SW103</th> </tr> <tr> <th>1</th> <th>2</th> <th>3</th> <th>4</th> </tr> </thead> <tbody> <tr> <td>Heat pump model</td> <td>OFF</td> <td>ON</td> <td>OFF</td> <td>OFF</td> </tr> <tr> <td>cool only</td> <td>ON</td> <td>ON</td> <td>OFF</td> <td>ON</td> </tr> </tbody> </table>	RC number	DIP switch-SW103				1	2	3	4	Heat pump model	OFF	ON	OFF	OFF	cool only	ON	ON	OFF	ON
	RC number		DIP switch-SW103																	
		1	2	3	4															
Heat pump model	OFF	ON	OFF	OFF																
cool only	ON	ON	OFF	ON																
r2	Two or more different indoor units are connected to this network convertor. When the communication system is different, the indoor unit cannot be connected. Contact the service personnel for details.																			
r3	DIP switch setting is setting outside the ratings or of a group remote controller. After checking, perform setting again.																			
r9	PATTERN2 is set at a PATTERN1 type indoor unit. Or PATTERN1 is set at a PATTERN2 type indoor unit. After checking, perform setting again.																			

Note:

Error display only displays 1 type even when there are multiple error causes.

Priority order: **r3** > **r9** > **r2** > **r1**

- (6) After the countermeasures method was performed, perform the setting check mode again.

Note:

When returned to normal operation, or when the DIP switch is set again or the setting check mode is performed, turn on the power of each indoor unit and this unit again. (If the power is not turned on again, normal operation will be impossible.)

16. ERROR CODE DISPLAY

Error code	Contents
□	No error (operation mode)
88	Initial setting
C1	Main PCB error
12	Remote controller communication error
16	Peripheral device communication error
CA	EEPROM error
26	Address setting error
SU	Indoor unit error

When error occurs in the remote controller connected to the network convertor, please refer to the installation manual of the remote controller and indoor unit.

* LONWORKS® is registered trademark of Echelon Corporation in the United States and other countries.