

UTY-VLGX

INSTALLATION MANUAL

NETWORK CONVERTOR
For authorized service personnel only.

安装说明书

网络转换器
只适用于专业维修人员

MANUEL D'INSTALLATION

ADAPTATEUR RESEAU
Uniquement réservé aux techniciens agréés.

MANUAL DE INSTALACIÓN

CONVERTIDOR DE RED
Sólo para personal de mantenimiento autorizado.

MANUAL DE INSTALAÇÃO

CONVERSOR DE REDE
Apenas para técnicos de assistência autorizados.

English

中文

Français

Español

Português

INSTALLATION MANUAL

PART NO. 9708436029
NETWORK CONVERTOR

Contents

1. SAFETY PRECAUTIONS	1
2. MAIN UNIT AND ACCESSORIES	1
3. ELECTRICAL REQUIREMENT	2
4. SELECTING AN INSTALLATION LOCATION	2
4. 1. Dimensions	2
5. WIRING	2
5. 1. Wiring method	3
6. INSTALLING THE NETWORK CONVERTOR	4
6. 1. Connecting the power supply cable	4
6. 2. Connecting the transmission cables	4
7. TURNING ON THE POWER	5
8. ADDRESS SETTING	5
9. INITIAL SETTING (SOFTWARE)	6
10. BINDING & COMMISSIONING (NOTICE)	6
11. LED DISPLAY (D19).....	6

1. SAFETY PRECAUTIONS

- The "SAFETY PRECAUTIONS" indicated in this manual contain important information pertaining to your safety. Be sure to observe them.
- Request the user to keep this manual on hand for future use, such as for relocating or repairing the unit.

WARNING

This mark indicates procedures which, if improperly performed, might lead to the death or serious injury of the user.

Perform electrical work by an authorized service personnel in accordance with this manual and the electrical wiring regulations or implementation regulations of the country. Also do not install this unit by yourself. Improper electric work will cause electric shock or a fire.

Perform installation work in accordance with this manual. Request an authorized service personnel to perform installation work. Do not install this unit by yourself. Improper installation will cause injury, electric shock, fire, etc.

In the event of a malfunction (burning smell, etc.), immediately stop operation, turn off the electrical breaker, and consult authorized service personnel.

Install a leakage circuit breaker to power supply cable in accordance with the related laws and regulations and electric company standards.

Use a power source exclusively for this unit. Never share the power source with other electrical equipment. Doing so will cause fire and electric shock.

Do not install the unit in the following areas:

- Do not install the unit near a source of heat, steam, or flammable gas.
- Area filled with mineral oil or containing a large amount of splashed oil or steam, such as a kitchen. It will deteriorate plastic parts, causing the parts to fail or the unit to leak water.

- Area that generates substances that adversely affect the equipment, such as sulfuric gas, chlorine gas, acid, or alkali. It will cause the copper pipes and brazed joints to corrode, which can cause refrigerant leakage.
- Area containing equipment that generates electromagnetic interference. It will cause the control system to malfunction, preventing the unit from operating normally.
- Area that can cause combustible gas to leak, contains suspended carbon fibers or flammable dust, or volatile inflammables such as paint thinner or gasoline. If gas leaks and settles around the unit, it can cause a fire.
- Do not use the unit for special purposes, such as storing food, raising animals, growing plants, or preserving precision devices or art objects. It can degrade the quality of the preserved or stored objects.
- Install the unit in a well-ventilated place avoiding rains and direct sunlight.

Do not operate this unit when your hands are wet. Touching the unit with wet hands will cause an electric shock.

If children may approach the unit, take preventive measures so that they cannot reach the unit.

CAUTION

This mark indicates procedures which, if improperly performed, might possibly result in personal harm to the user or damage to property.

Pay abundant care when transporting this unit because it is a precision device. Improper transportation will cause trouble.

Do not touch the switches with sharp objects. Doing so will cause injury, trouble, or electric shock.

Do not expose this unit directly to water. Doing so will cause trouble, electric shock, or heating.

Do not set vessels containing a liquid on this unit. Doing so will cause heating, fire, or electric shock.



Dispose of the packing materials safely. Tear and dispose of the plastic packing bags so that children cannot play with them. There is the danger of suffocation if children play with the original plastic bags.



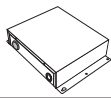

Do not insert articles into the slit parts of this unit. Doing so will cause trouble, heating, or electric shock.

2. MAIN UNIT AND ACCESSORIES

Important: Please print manual other than the installation manual from attached CD-ROM before starting the installation work.

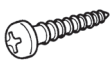
The following installation parts are supplied. Use them as required.

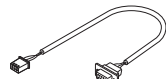
Name and Shape	Q'ty	Application
Network convertor 	1	Main unit
Installation manual 	1	This manual
Binder 	3	For mounting the power supply cable and transmission cable.

Screw (M4 x 20 mm) 	4	For mounting the Network Converter.
CD-ROM 	1	For initial setting.
Connector cable 	1	For initial setting tool and manuals.
Dust proof bushing 	1	For connecting the power supply cable. (Except in U.S.A. and Canada)

3. ELECTRICAL REQUIREMENT

Use	Size	Wire type	Remarks
Power supply cable	Maximum	1.25 mm ² (16AWG)	1Ø AC208–240 V 50/60Hz, 2 Cable + earth (ground) [Always earth (ground) the unit]
	Minimum	0.5 mm ² (20AWG)	
Transmission cable	0.33 mm ² (22AWG)	22AWG LEV-EL4 (NEMA) nonpolar 2 core, twisted pair solid core Shielded	LONWORKS® compatible cable
Fuse capacity	3 A		

* LONWORKS® is registered trademark of Echelon Corporation in the United States and other countries.

4. SELECTING AN INSTALLATION LOCATION

4.1. Dimensions

The Network Converter is comprised of a body and cover.

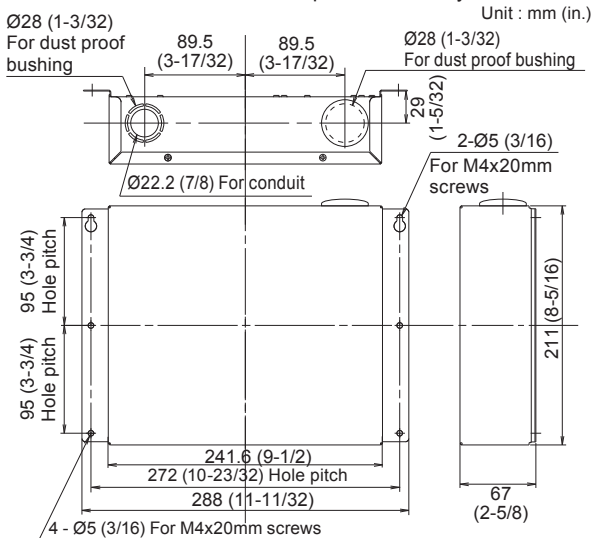

Power supply	1Ø AC208–240V 50/60 Hz
Power consumption (W)	4.5

Temperature °C(°F)	Operating	0–46 (32–114)
	Packaged	-10–60 (14–140)
Humidity (%)	Packaged	0–95 (RH); No condensation
Dimensions H x W x D mm(in.)		67 x 288 x 211 (2-5/8 x 11-11/32 x 8-5/16)
Weight g (oz.)		1500 (53)

5. WIRING

⚠ WARNING

Before starting installation work, turn off the power of this unit and the connection destination. Do not turn on the power again until installation is completed. Otherwise, it will cause electric shock or fire.

Use the accessories or specified power supply cable and transmission cables. Do not modify power supply cable and transmission cables other than those specified, do not use extension cables, and do not use independent branch wiring. Overcurrent may cause electric shock or fire.

Install the transmission cables securely to the terminal block. Confirm that external force is not applied to the cable. Use transmission cables made of the specified cable. If intermediate connection or insertion fixing are imperfect, it will cause electric shock, fire, etc.

When connecting the power supply cable and transmission cable, route the cables so that the cover of this unit is securely fixed. If the cover is imperfectly fixed, it may cause fire or overheating of the terminals.

Perform earth (ground) work positively. Do not connect the earth (ground) cable to a telephone cable, water pipe, or conductor rod.

Always fasten the outside covering of the transmission cables with the cable clamp. (If the insulator is chafed, electric leakage may occur.)

Perform all wiring works so that the user does not touch the wiring. Otherwise, injury or electric shock could result.

If any cable is damaged, do not repair or modify it yourself. Improper work will cause electric shock or fire.

⚠ CAUTION

Do not bind the remote controller cable and the transmission cable together with or parallel to the power supply cable of the indoor and outdoor units. It may cause erroneous operation.

When performing wiring work, be careful not to damage the cable or injure yourself. Also, connect the connectors securely. Loose connectors will cause trouble, heating, fire, or electric shock.

Install the indoor and outdoor units, power supply cable, transmission cable and remote control cable 1 m (40 in.) away from television and radio to avoid distorted images and noise. Otherwise, a malfunction could result.

Perform wiring so that water does not enter this unit along the external wiring. Always install a trap to the wiring or take other countermeasures. Otherwise it will cause trouble or electric shock or fire.

Confirm the name of each unit and name of each terminal block of the unit and connect the wiring in accordance with the directions given in the manual so that there is no incorrect wiring. Incorrect wiring will damage the electric parts and cause smoke and fire.

When installing the connection cables near a source of electromagnetic waves, use shielded cable. Otherwise, a breakdown or malfunction could result.

The terminal screws and earth (ground) screws have different shapes. Be sure to install the screws in the correct locations. If the screws are installed in the wrong locations, the circuit board could be damaged.

5.1. Wiring method

PROPER SYSTEM DIAGRAM

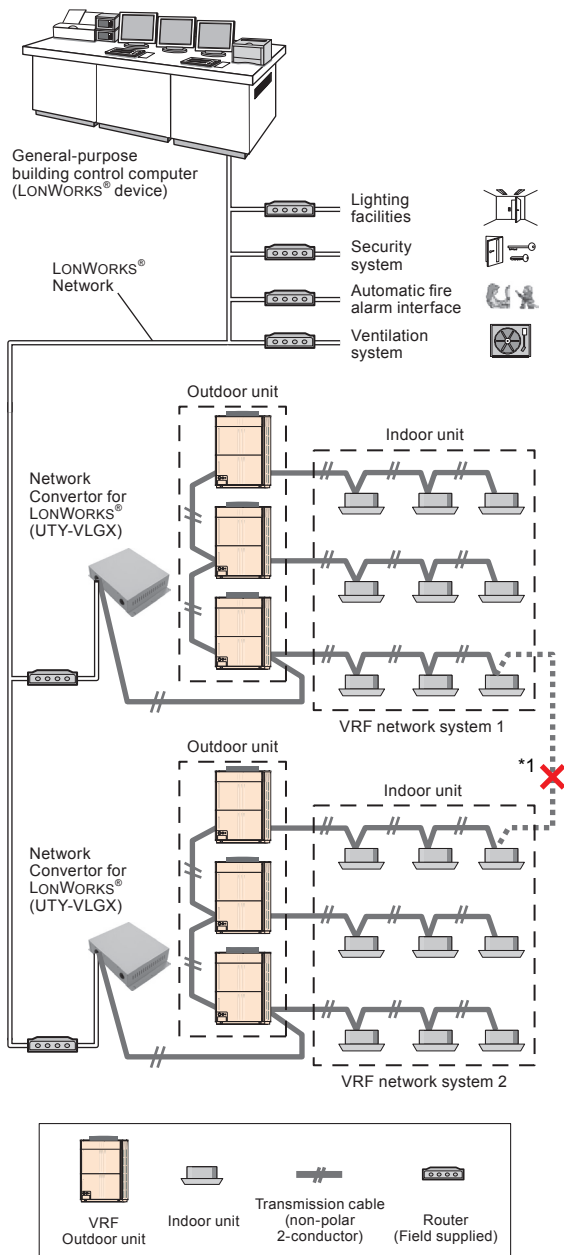

Note :

Router should be needed by the number of controlling items in the BMS.

*1. Please do not make the connection like this between VRF systems.

Maximum connectable indoor unit number per 1 Network Converter	128
Maximum connectable outdoor unit number per 1 Network Converter	100
Maximum connectable Network Converter number per 1 BMS	4
Maximum connectable Network Converter number per 1 VRF System	1

ELECTRICAL WIRING

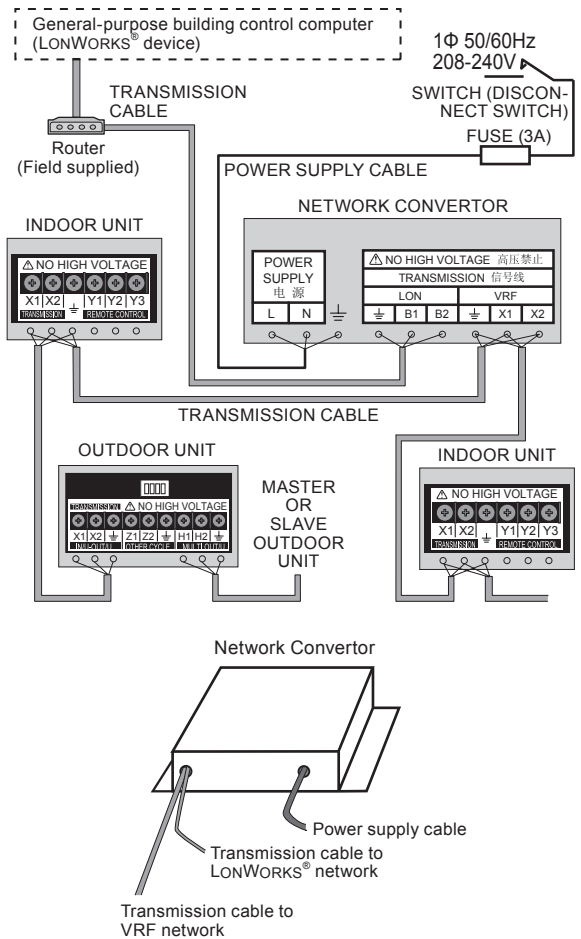

Note :

- Do not bind the power supply cable and transmission cable to avoid an erroneous operation.
- Use shield cable for transmission cable. The shield metal should be earthed (grounded).
- Do not forget to earth (ground) the Network Converter.
- Install the disconnect switch to the easily accessible location.
- Install the fuse (3A) to the L line of power supply cable.

6. INSTALLING THE NETWORK CONVERTOR

⚠ WARNING

Always use the accessories and specified installation work parts. Check the state of the installation parts. Not using the specified parts will cause units to fall off, water leakage, electric shock, fire, etc.

Install at a place that can withstand the weight of the unit and install positively so that the unit will not topple or fall.

When installing this unit, make sure that there are no children nearby.

Otherwise, injury or electric shock could result.

Install a circuit breaker.

Otherwise, electric shock or fire could result.

⚠ CAUTION

Before opening the cover of this unit, completely discharge static electricity charged on your body. Otherwise, failure or malfunction could result.

Do not touch the circuit board and circuit board parts directly with your hands.

Otherwise, injury or electric shock could result.

Tightening the mounting screws too tight will damage the body of this unit.

Be careful so that the cover does not fall after the cover screws are removed.

Otherwise, injury could result.

6.1. Connecting the power supply cable

for U.S.A. and Canada

- Remove the 4 screws (M4 × 6 mm), and then remove the cover.
- Install the conduit.
- Fix the conduit with lock nut.
- Pass the power supply cable through the conduit.
- Connect the power supply cable to their respective terminal block and the earth (ground).
- Securely tighten the binder and then confirm that the cable will not come out.

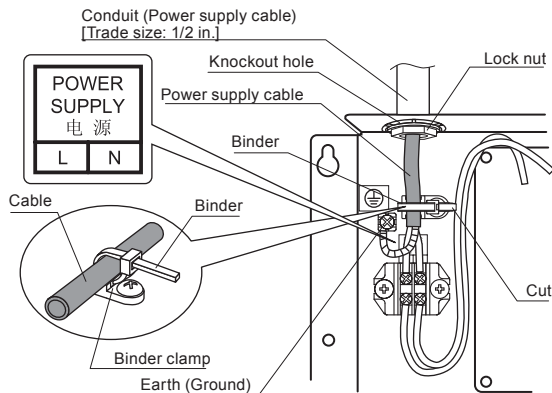

for Others

- Remove the 4 screws (M4 × 6 mm), and then remove the cover.
- Open the knockout hole, and then install dust proof bushing. If small animals such as insects and dust enter this unit, a short circuit may be caused.

- Make a hole in the center of the dust proof bushing with the Phillips head screwdriver.
- Pass the power supply cable through the hole of dust proof bushing and pull it into the network convertor.
- Connect the power supply cable to their respective terminal block and the earth (ground).
- Securely tighten the binder and then confirm that the cable will not come out.

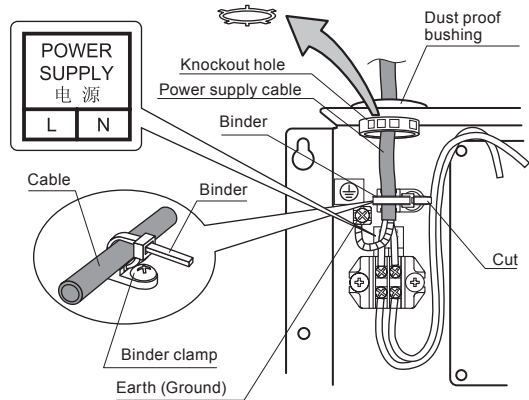

Tightening torque for installing cables to terminal block

0.8 to 1.2 N • m (7.1 to 10.6 lbf • in)

6.2. Connecting the transmission cables

- Turn the power off.
- Make a hole in the center of the dust proof bushing with the Phillips head screwdriver.
- Pass the transmission cables through the hole of dust proof bushing and pull it into the network convertor.
- Connect the transmission cables to their respective terminal block properly.
- Securely tighten the binders and then confirm that the cable will not come out.
- Once the wiring of the cables has been completed, mount the cover to the network convertor. Use the screws (M4 × 6 mm) to mount the cover.
- Use the 4 screws (M4 × 20 mm) provided to mount the network convertor to the behind ceiling, wall, floor or other suitable location.

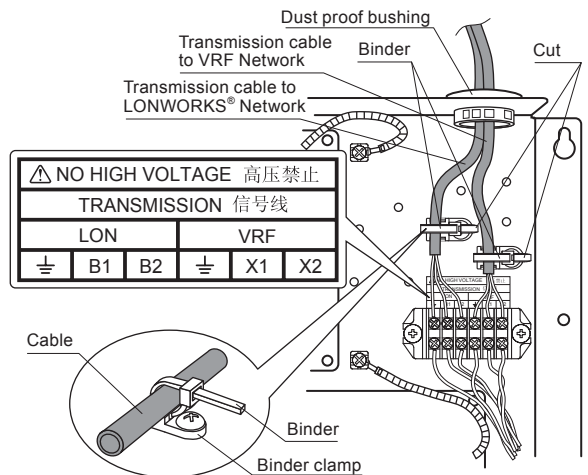

Tightening torque for installing cables to terminal block

0.8 to 1.2 N · m (7.1 to 10.6 lbf · in)

7. TURNING ON THE POWER

⚠ CAUTION

Check that the power supply voltage is within the specified range. If the power supply voltage outside the specification is input, it will cause trouble.

Recheck the wiring. Incorrect wiring will cause trouble.

- Check the Network Converter wiring.
- Check the wiring and switch settings for the VRF system and turn on the power for the VRF system. For the wiring and switch setting method, refer to the installation manual of each unit.
- Set the Jumper switch 1 (JP1) in order to set "Back up battery ON". (Fig.)
(This is necessary in order to save the initial setting data and commissioning data to SRAM.)



- Turn on the power for the Network Converter.

Note: In procedure (3), the purpose of setting Jumper switch (JP1) is to make the backup battery effective. The backup battery can save the Tool for Network Converter and Network Integration Tool setting information. Therefore, it is not necessary to keep effective before those setting works are done.

- The Network Converter is initialized for a period of approximately a few seconds after the power is turned on. **88** is displayed on D19 during this period.
 - After initial setting completely, the operation mode will be started.
 - Anyone of the following indication will displayed:
 - 88** : VRF Network address allocation is not registered by using Tool for Network Converter
 - : Binding and Commissioning is not executed
 - 88** : Normal Mode (Ready for operation)
 - : Others (Refer to "11. LED DISPLAY (D19)" for more detail.)
- * Network Converter does not operate during initialization.
* If an error occurs, the D9 or D14 LED lights or flashes, or the error code is displayed on the right side of the D19 LED display.

8. ADDRESS SETTING

- Setting up more than 1 Network Converter in 1 VRF network system is prohibited.
- When setting address, please be sure that the address of Network Converter is not overlap the address of other controller like, Touch Panel Controller & Network Converter for Group Remote Controller.

SWITCH POSITION

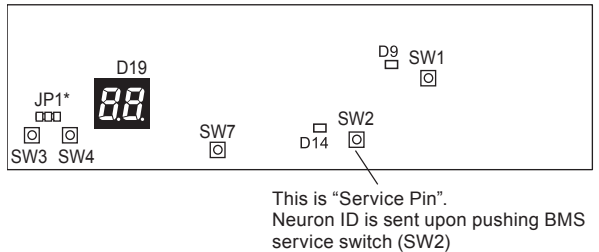

Following steps are necessary for setting address of Network Converter.

- Turn on the power of Network Converter.

- Select the special mode by pressing and releasing SW7 (reset button) while holding down SW4 (set button) until special mode "1" (Blinking) is displayed. Please keep holding down SW4 (set button) a few seconds after releasing the SW7 (reset button).



When SW3 (mode button) is pressed, special mode changes from '1' to '4' (Blinking) as the as shown in the above mentioned way.

- Press SW3 (mode button) to set special mode "2". Special mode "2" is the address setting mode.

- Press SW4 (set button). Present address is displayed.



- Press SW3 (mode button) to select the address. The displayed address changes as follows each time the mode button is pressed.

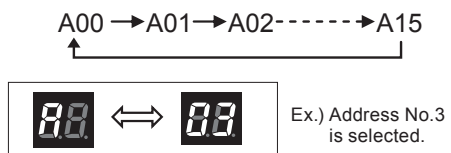

- Press SW4 (set button) to set the selected address.



7. Turn the power off and on or press SW7 (reset button) to exit from address setting mode. This time, please refer to the "7. TURNING ON THE POWER" for the content displayed in D19 LED.

9. INITIAL SETTING (SOFTWARE)

The initial settings for the Network Converter must be performed before the commissioning. Please see the attached "Application Manual - Tool for Network Converter" and complete the settings.

10. BINDING & COMMISSIONING (NOTICE)

- (1) It is necessary to make an XIF (External Interface File) for binding.
- (2) The commissioning doesn't end if the number of Indoor/Outdoor Unit of the XIF file made with Tool for Network Converter is not in consistency with the number after Indoor/Outdoor Unit Address is registered.
In addition, the Network Converter can not operate normally if the number of Indoor/Outdoor Unit of the XIF file is not in consistency with the number after Indoor/Outdoor Unit Address is registered.
- (3) Binding and commissioning must be performed again if the number of connecting units (indoor/outdoor units) has changed after system operation. Please always register the allocation information that is in consistency with the VRF system, Functional Block in the Network Converter and the Network Converter, if register the changed XIF file in according to the "Tool for Network Converter".





Important:

Network Converter will not operate if,

- VRF network system address (Indoor & Outdoor units address) allocation information are not registered to Network Converter.
- XIF data information and VRF network system address allocation information must not be same.
- Binding & Commissioning is not executed.
- The ID number registered on Network Converter is different from the ID number when XIF file is created.
- Two or more Network Convertors are connected to BMS, and these are set the same ID number.







11. LED DISPLAY (D19)

(1) Normal code

Normal code	Contents
	Normal mode
	Set state of "Tool for Network Converter"
	Address setting mode
	Under maintenance
	FB and unit address allocation information is registered with "Tool for Network Converter"

FB* : Functional Blocks

(2) Error code

Error code	Contents
	FB and unit address allocation information is not registered
	Main PCB error
	VRF Network error
D9 LED lit or blinking 	Communication error (Error of the Network Interface Device on VRF System)
D14 LED lit or blinking 	Communication error (Error of the Network Interface Device on BMS)*1
	When V series or S series is connected

*1. D14 is ON for 1 second, OFF for 1 second, and repeats. When D19 is in Normal mode, Commissioning is unset.