

AIRSTAGE™ VR-II





Variable Refrigerant Flow System

4. TROUBLE SHOOTING



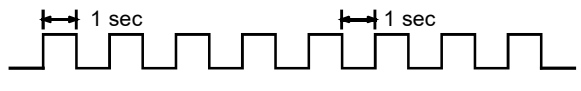
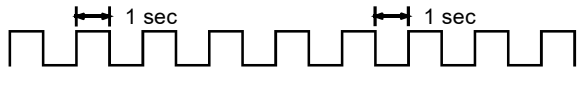

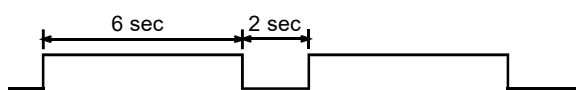

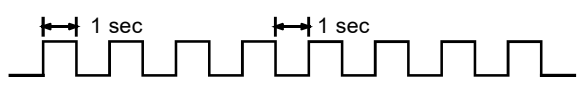
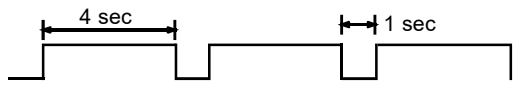





4. TROUBLESHOOTING

4-1 NORMAL OPERATION

4-1-1 Indoor Unit Display

Indication type	Indication Lamp	Flashing Pattern
Operation	Operation LED	Continuous lighting
Anti Freeze		Continuous lighting(lowered light)
Timer	Timer LED	Continuous lighting(lowered light)
Filter	Filter LED	Continuous lighting
Power Failure	Operation LED	ON OFF 
	Timer LED	ON OFF 
Test Operation	Operation LED	ON OFF 
	Timer LED	
Defrosting	Operation LED	ON OFF 
Oil Recovery		
Opposite Operation Mode	Timer LED	ON OFF 
Maintenance Mode	Operation LED	ON OFF 
	Timer LED	
	Filter LED	
Location Notification	Operation LED	ON OFF  This function is only available on the 2 wires remote controller. Please refer to the installation manual of UTY-RNR*
	Timer LED	
	Filter LED	

4-1-2 OUTDOOR UNIT DISPLAY

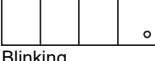
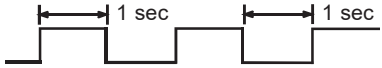
Indication type	7 Segment LED Pattern	Description
Idling(stop)	 Blank	
Cooling Mode (Mainly Cooling)	 "C" "OO" "L"	
Heating Mode (Mainly Heating)	 "H" "EA" "T"	
Oil Recovery Operation	 "O" "IL" "R" ECOVERY	Refer to Chapter 02. (Outdoor unit operation control)
Defrost Operation	 "D" "E" "F" ROST	Refer to Chapter 02. (Outdoor unit operation control)
Discharge Temp. Protection is stopped	 "P" ROTECT "1"	<Starting condition> Discharge temp \geq fixed value 239°F(115°C) <Release condition> 3 minutes have elapsed and discharge temperature \leq 176°F(80°C)
High Pressure Protection is stopped	 "P" ROTECT "2"	<Starting condition> High pressure \geq 611psi(4.00MPa) or Pressure SW in operation <Release condition> 5 minutes have elapsed and high pressure \leq 509psi (3.50MPa) and Pressure SW release
Low Pressure Protection is stopped	 "P" ROTECT "3"	<Starting condition> Low pressure \leq 7psi (0.05MPa) or low pressure \leq 15psi (0.10MPa) continues for 10 mins <Release condition> 3 minutes have elapsed and low pressure \geq 25psi (0.17MPa)
Compressor Temperature Protection is stopped	 "P" ROTECT "4"	<Starting condition> Compressor temp \geq fixed value 239°F(115°C) <Release condition> 3 minutes have elapsed and discharge temperature \leq 176°F(80°C)
Peak Cut Mode	 "P" eak "C" ut	
Low Noise Mode	 "L" OW "N" OISE	Refer to Chapter 02. (Outdoor unit operation control)
Snow Falling Protection Fan mode	 "SN" OW	Refer to Chapter 02. (Outdoor unit operation control)
Inverter Compressor Operation Indication	 Blinking	ON  OFF

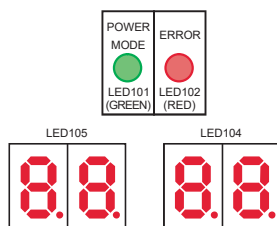

4-2-1 Error code Display

An Error code is represented by 3 digit characters.

The first 2 digit means the subsection Error code, and the last 1 digit means the specifics Error code.

Ex.) Indoor unit Network communication Error

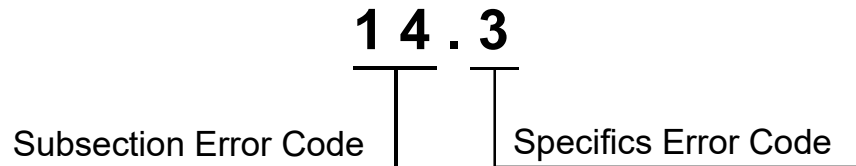

14 : Network communication Error

3 : Indoor unit Network Communication Error

Each Error code section is shown by the following target

Subsection Error Code target	Subsection and Specifics Error code target
<ul style="list-style-type: none"> - Indoor unit (Operation / Timer / Filter) LED - 2 / 3 Wires Remote controller - Simple Remote controller - Group Remote controller - Central Remote controller - Touch - Panel Controller 	<ul style="list-style-type: none"> - Outdoor unit 7 segment Display - Service Tool

When an Error occurs, each devices indicate own abnormal detecting condition.

In order to confirm the actual error condition, the following procedure are required.

1) Confirm the Specific Error code on the Outdoor unit 7 segment display or the Service tool.

Ex.1.) When the wired remote controller shows " 9 U (Outdoor unit Error)".

Ex.2*) When the wired remote controller shows " 4 2 (Indoor unit Heat-Ex Sensor Error)"

*The Specific Error code can be indicated by service tool.

2) Confirm each Error code on each devices in case of Network communication Error.

Ex.) When the Network cable of indoor unit 00 disconnected during operating.

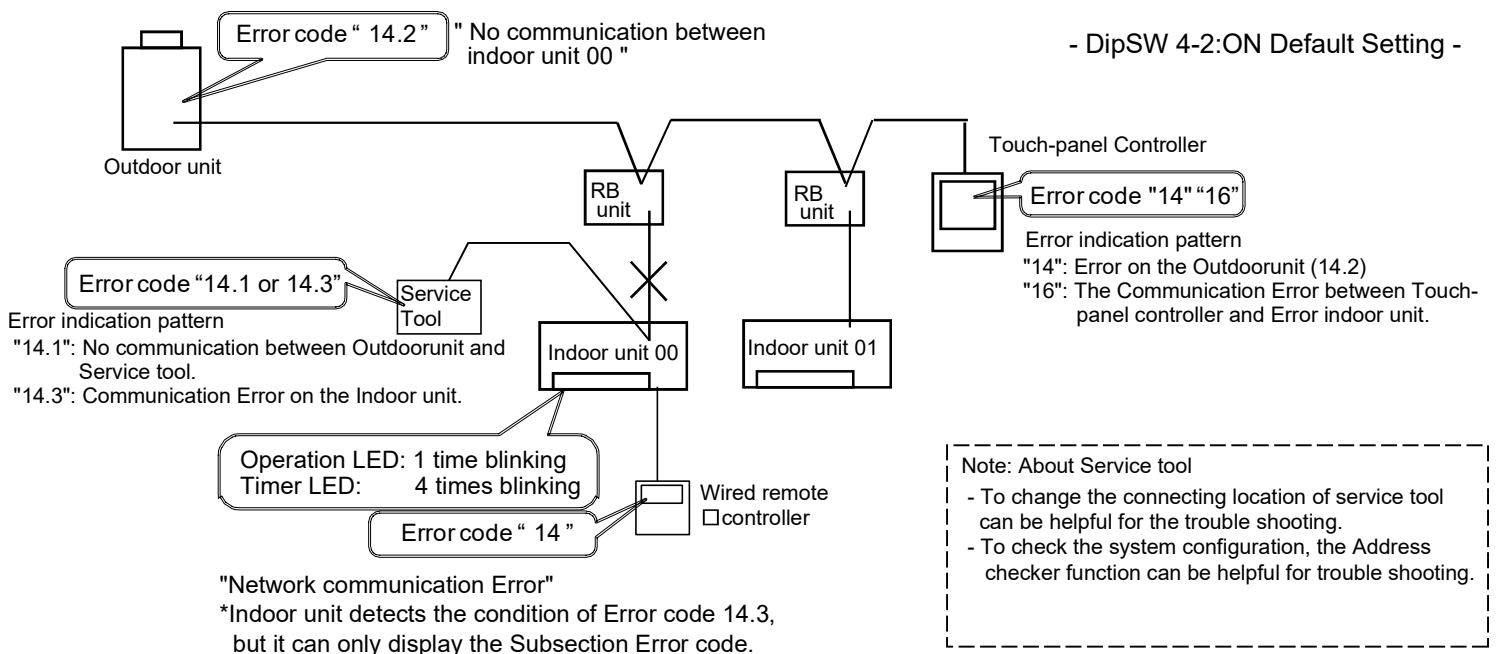

4-2-2 Indoor Unit Display

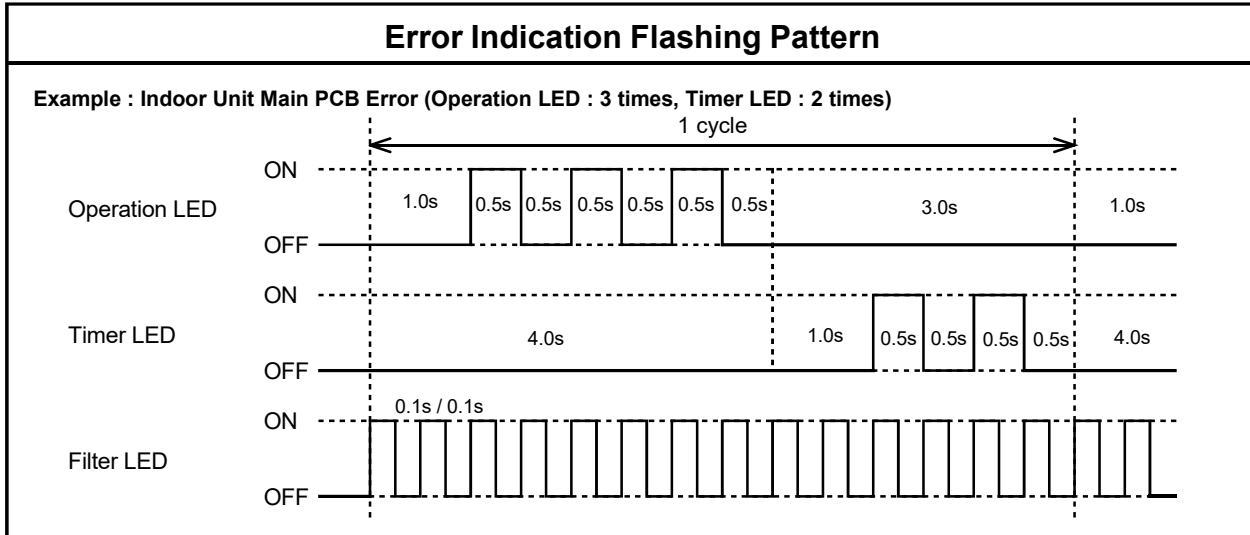

4-2-3 Outdoor Unit Display

LED display

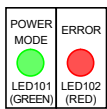

POWER MODE LED : on
ERROR LED : blink



Operation button

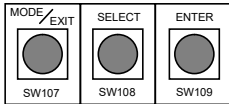

ERROR transition

Short press : less than 3 seconds
Long press : more than 3 seconds

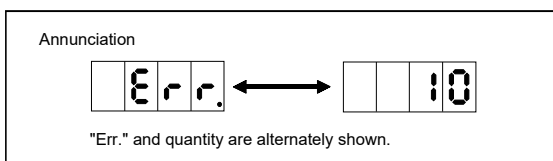

"ENTER" short press

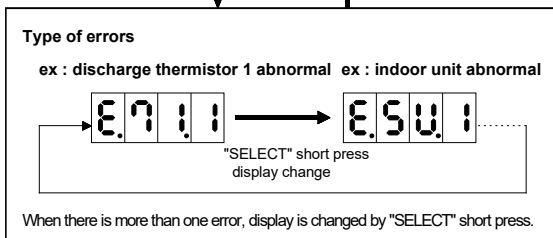

"ENTER" long press *

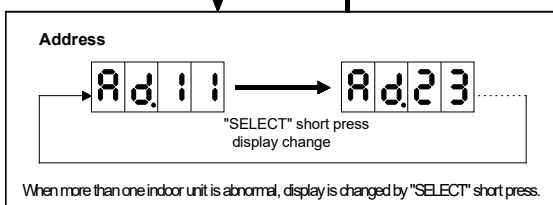

If some error is newly occurred or resolved during transition, it is reflected after going back to "Annunciation".

* Only in the case of "indoor unit abnormal (E.5U.1)", indoor unit address is shown by ENTER long press.

4-2-4 Remote Controller Display

<< SIMPLE REMOTE CONTROLLER >>

ERROR CODE DISPLAY

If an error occurs, the following display will be shown.
 ("Er" will appear in the set room temperature display.)
 If "Er" is displayed, immediately contact authorized service personnel.

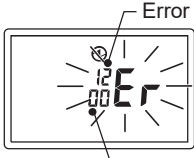

Ex. Error code display

<< WIRED REMOTE CONTROLLER 3 wire type>>

ERROR CODE DISPLAY

If an error occurs, the following display will be shown.
 ("Er" will appear in the set room temperature display.)
 If "Er" is displayed, immediately contact authorized service personnel.

Unit number (usually 0)

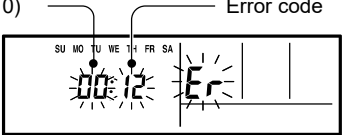

Ex. Error code display

<< WIRED REMOTE CONTROLLER 2 wire type>>

If an error occurred, an error icon appears on the Monitor mode screen.

Conference Fri 10:00AM

Mode	Set Temp.	Fan

-Status Menu

-Status Page 1/3

Air Flow Direction

VT1	Hz
1	3
Economy	Anti Freeze
Off	Off

Monitor Next Page Error Information

Error Information Page 1/5

Address	[02-01]
Error Code	[12, 14]

Back Next Page

1. Touch the [Status] on the Monitor mode screen.
2. Touch the [Error Information] on the Status screen.

2-digit numbers are corresponding to the error code

<< GROUP REMOTE CONTROLLER >>

ERROR CODE DISPLAY

The air conditioning system must be inspected if "E : " (error code) appears on the timer and Clock Display, or the operation lamp is flashing.

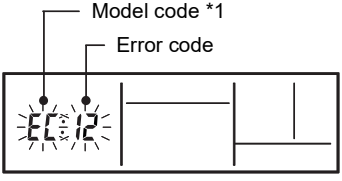

Ex. Error code display

*1 ; Model code

- O : Outdoor unit
- I : Indoor unit
- G : Group remote controller
- R : Convertor

4-2-5 Trouble shooting index - Error code List 1/2 -

Display Target A	Display Target B	Display Target C	Display Target D
Simple Wired remote controller 2 / 3 wires Wired remote controller Indoor unit LED brinking times, " 1st figure: Operation LED, 2nd figure: Timer LED"	Group Remote controller Central Remote controller Touch- Panel controller	7 seg. Display on Outdoor unit Controller PCB	Service Tool

* : No Display A: LED 10 times Blinks J: LED 13 times Blinks U: LED 15 times Blinks

Display Target A	Display Target B	Error Contents < Subsection >	Display Target C	Display Target D	Error Contents < Supecifics >	Trouble shooting No.
1 2		Remote controller Communication Error	5 U.1	1 2 . 1 1 2 . 2 1 2 . 3	Wired Remote Controller communication Error Wired Remote Controller signal error (3 wires RC) Number Excess of device in Wired RC. System (2 Wires RC)	1 2 3
9 U	1 3	Communication Error between Outdoor unit		1 3 . 1	Communication Error Between Outdoor unit	4
1 4 *	1 4 1 6	Network Communication Error	1 4 . 1	1 4 . 1 1 4 . 3	Outdoor unit Network communication 1 Error	5
1 4 9 U	1 4 1 6		1 4 . 2	1 4 . 2 1 4 . 1 1 4 . 3	Outdoor unit Network communication 2 Error	6
1 4 9 U *	1 4 1 6		1 4 . 1 1 4 . 2	1 4 . 3 1 4 . 1 1 4 . 2	Indoor unit Network communication Error	7
9 U *	1 4 1 6		1 4 . 5	1 4 . 5 1 4 . 3	The number of indoor unit shortage Error	8
1 6 *		Peripheral device communication Error	1 4 . 1 1 4 . 2	1 4 . 3	Transmission PCB connection Error Communication Error between Controller and Indoor unit	9 10
2 6		Address settingError	5 U.1	2 6 . 4 2 6 . 5	Address duplication in Wired remote controller system Address setting Error in Wired remote controller system	11 12
*		Other setting Error	2 8 . 1 2 8 . 4	* *	Auto address setting Error Signal amplifier auto address Error	13 14
2 9 2 9	* *	Connection unit number error in wired remote controller system	5 U . 1 *	2 9 . 1 *	Connection unit number Error (Indoor unit in WRC control system) Connection unit number Error (Remote controller)	15 16
3 1		Indoor unit Power supply Abnormal	5 U . 1	3 1 . 3	Indoor unit power frequency Abnormal	17
3 2		Indoor unit Main PCB Error		3 2 . 1 3 2 . 3	Indoor unit PCB Model informaiton Error Indoot unit EEPROM access Error	18 19
3 A		Indoor unit communication circuit (WRC) error	5 U.1	3 A . 1	Indoor unit communication circuit (WRC) microcomputers communication error	20
4 1		Indoor unit Room temp. Sensor Error		4 1 . 1	Indoor unit Inlet air temp. Sensor Error	21
4 2		Indoor unit Heat-Ex. Sensor Error		4 2 . 1 4 2 . 3	Indoor unit Heat-Ex. Inlet temp. Sensor Error Indoor unit Heat-Ex. Outlet temp. Sensor Error	22 23
5 1		Indoor unit FAN Motor 1 Error		5 1 . 2	Indoor unit FAN Motor 1 rotation speed Error	24
5 2		Indoor unit Coil (EEV) Error		5 2 . 1	Indoor unit Coil 1 (EEV) Error	25
5 3		Indoor unit water drain Abnormal		5 3 . 1	Indoor unit Drain pump Error	26
*		Indoor unit Error		*	Indoor unit Error	Refer to I.U Error
9 U	6 1 6 2	Outdoor unit Power supply Abnormal Outdoor unit PCB Error		6 1 . 5 6 2 . 3 6 2 . 6 6 2 . 8	Outdoor unit reverse phase, missing phase wire Error Outdoor unit EEPROM access Error Inverters communication Error EEPROM data corrupted Error	27 28 29 30
	6 3	Outdoor unit Inverter PCB Error		6 3 . 1	Inverter Error	31
*	*	OU. short interruption detection protected operation		6 7 . 2	Inverter PCB short interruption Error	32
9 U	6 8	Outdoor unit Magnetic relay Error		6 8 . 2	Rush Current limiting resistor temp. rise protection	33
9 U	6 9	Outdoor unit Transmission PCB Error		6 9.1	Outdoor unit transmission PCB Parallel communication Error	34
1 4	1 4		6 9.1	1 4 . 1 1 4 . 3		
9 U	7 1 7 2 7 3	Outdoor unit Discharge temp. Sensor Error Outdoor unit Compressor temp. Sensor Error Outdoor unit Heat-Ex. temp. Sensor Error		7 1 . 1 7 2 . 1 7 3 . 4 7 3 . 5 7 3 . 6 7 3 . 7	Discharge temp.Sensor 1 Error Compressor temp. Sensor 1 Error Heat-Ex 1 gas temp. Sensor Error Heat-Ex 1 liquid temp. Sensor Error Heat-Ex 2 gas temp. Sensor Error Heat-Ex 2 liquid temp. Sensor Error	35 36 37 38 39 40
	7 4	Outdoor temp. Sensor Error		7 4 . 1	Outdoor temp. Sensor Error	41
	7 5	Suction gas temp. Sensor Error		7 5 . 1	Suction gas temp. Sensor Error	42
	7 7	Heat sink temp. Sensor Error		7 7 . 1	Heat sink temp. Sensor Error	43
	8 2	Sub cool HEX temp. Sensor Error		8 2 . 2	Sub cool HEX gas outlet temp. Sensor Error	44
	8 3	Liquid pipe temp. Sensor Error		8 3 . 1 8 3 . 2	Liquid pipe temp. Sensor 1 Error Liquid pipe temp. Sensor 2 Error	45 46
	8 4	Current Sensor Error		8 4 . 1	Current sensor 1 Error	47

4-2-5 Trouble shooting index - Error code List 2/2 -

Display Target A	Display Target B	Display Target C	Display Target D
Simple Wired remote controller 2 / 3 wires Wired remote controller Indoor unit LED blinking times, " 1st figure: Operation LED, 2nd figure: Timer LED"	Group Remote controller Central Remote controller Touch- Panel controller	7 seg. Display on Outdoor unit Controller PCB	Service Tool

* : No Display A: LED 10 times Blinks J: LED 13 times Blinks U: LED 15 times Blinks

Display Target A	Display Target B	Error Contents < Subsection >	Display Target C	Display Target D	Error Contents < Suppecifics >	Trouble shooting No.
9 U	8 6	Pressure Sensor Error	8 6 . 1		Discharge pressure sensor Error	48
			8 6 . 3		Suction pressure sensor Error	49
			8 6 . 4		High pressure SW 1 Error	50
	9 3	Compressor start up Error	9 3 . 1		Inverter compressor Start up Error	51
	9 4	Trip Detection	9 4 . 1		Trip detection	52
	9 5	Compressor motor control Error	9 5 . 5		Compressor motor loss of synchronization	53
	9 7	Outdoor unit FAN Motor 1 Error	9 7 . 1		Outdoor unit FAN Motor Lock Error	54
			9 7 . 5		Outdoor unit FAN Motor temp. Abnormal	55
			9 7 . 9		Outdoor unit FAN Motor Driver Abnormal	56
	9 A	Outdoor unit coil (EEV) Error	9 A . 1		Coil 1 (EEV) Error	57
			9 A . 2		Coil 2 (EEV) Error	58
			9 A . 3		Coil 3 (EEV) Error	59
	*1	Outdoor unit Abnormal	*1		Slave out door unit Error	60
	A 1	Discharge temp. Abnormal	A 1 . 1		Discharge temp. 1 Abnormal	61
	A 3	Compressor temp. Abnormal	A 3 . 1		Compressor 1 Temperature Abnormal	62
	A 4	Pressure abnormal 1	A 4 . 1		High pressure Abnormal	63
A 4 . 2				High pressure protection 1	64	
A 5	Pressure abnormal 2	A 5 . 1		Low pressure Abnormal	65	
A 6	Heat-Ex temp. Abnormal	A 6 . 3		Outdoor unit Heat-Ex 1 Gas temp. Abnormal	66	
		A 6 . 4		Outdoor unit Heat-Ex 2 Gas temp. Abnormal	67	
A C	Ambient temp Abnormal	A C . 4		Outdoor unit Heat Sink temp. Abnormal	68	
J 1	RB Unit Error	5 U . 1	J 1 . 1	RB Unit EEPROM Access Abnormal	69	
1 4		1 4 . 1	1 4 . 1	RB Unit transmission PCB2 parallel communication Error		
J 1		1 4 . 2	1 4 . 2			
	1 6		1 4 . 3		70	
			J 1 . 4			
*		Initial Setting Error	- - - -	*	Initial Setting Error	71

*1: Master Outdoor unit : 9 U . 2 / Slave Outdoor unit and Service Tool indicate applicable Error code

Outdoor Air unit

3 9	Indoor unit power supply circuit error	5 U . 1	39.1	Indoor unit power supply error for fan motor 1	81
			39.2	Indoor unit power supply error for fan motor 2	
4 A	Indoor unit air temp. thermistor error		4A.1	Indoor unit suction air temp. thermistor error	82
			4A.2	Indoor unit discharge air temp. thermistor error	83
5 9	Indoor unit fan motor 2 error	59.2	Indoor unit fan motor 2 rotation speed error	84	

Wired remote controller "Internal Error"

* These error codes will be shown only on the remote controller.

CC.1	*	Sensor Error	*	*	Replace the remote controller, If the error appears on the remote controller.
C2.1		Transmission PCB Error			
15.4		Data acquisition Error			

4-2-6 Trouble shooting index - No Error code -

	Error condition	Error Contents	Trouble shooting
No Error Code System Abnormal	Indoor Unit - No Power (Except Wall Mounted)	Indoor Unit - No Power (Except Wall Mounted)	72
	Indoor unit - No Power (Wall Mounted)	Indoor Unit -No Power(Wall Mounted)	73
	Outdoor unit - No Power	Outdoor unit - No Power	74
	RB Unit - No Power	RB Unit - No Power	75
	No operation (Power is ON)	No operation (Power is ON)	76
	No Cooling	No Cooling / No Heating	77
	Abnoemal Noise	Abnormal Noise	78
	Water leaking	Water leaking	79
	Indoor Unit - No Power(Outdoor air unit)	Indoor Unit - No Power (Outdoor air unit)	80

4-2-7 TROUBLE LEVEL OF SYSTEM

<< System Condition when Outdoor Unit Error is occurred >>

System Condition	Outdoor unit Condition	Trouble Level	
		1	2
		Not indicated on Indoor Unit and Peripheral unit. Indicated on Service Tool.	Indicated on Indoor Unit (*1) and Peripheral unit. Indicated on Service Tool.
① System is not stopped compulsorily Operation continues	Abnormal LED indication Outdoor unit does not stop	- 14.1 Outdoor unit network communication 1 error	- 62.3 Outdoorunit EEPROM access error - 62.8 EEPROM data corrupted error - 73.5 Heat Ex.1 liquid temp. sensor error - 73.7 Heat Ex.2 liquid temp. sensor error - 75.1 Suction gas temp sensor error - 82.2 Sub-cool Heat Ex. gas outlet temp. sensor error - 83.1 Liquid pipe temp. sensor 1 error - 83.2 Liquid pipe temp. sensor 2 error
② System is compulsorily stopped (*4)	Abnormal LED indication Outdoor unit stop	- 67.2 Inverter PCB short interruption detection	- 62.6 Inverter communication error - 63.1 Inverter error - 68.2 Rush current limiting resister temp. rise protection (*3) - 71.1 Discharge Temp sensor 1 error - 72.1 Compressor Temp sensor 1 error - 73.4 Heat Ex. 1 gas temp sensor error - 73.6 Heat Ex. 2 gas temp sensor error - 74.1 Outdoor Temp sensor error - 77.1 Heat sink Temp sensor error - 84.1 Current sensor 1 error (*3) - 86.1 Discharge pressure sensor error - 86.3 Suction pressure sensor error - 86.4 High pressure switch 1 error - 93.1 Inverter compressor start up error (*3) - 94.1 Trip detection (*3) - 95.5 Comp. motor loss of synchronization (*3) - 97.1 Outdoor unit fan motor lock error (*3) - 97.5 Fan motor temperature abnormal (*3) - 97.9 Fan motor driver abnormal (*3) - A1.1 Discharge temperature 1 abnormal (*3) - A3.1 Compressor1 temperature abnormal (*3) - A4.1 High pressure abnormal - A4.2 High pressure protection1 - A6.3 Outdoor Heat Ex. 1 gas temp. abnormal (*3) - A6.4 Outdoor Heat Ex. 2 gas temp. abnormal (*3) - AC.4 Heat sink temperature abnormal
③ System is compulsorily stopped	Abnormal LED indication Outdoor unit stop		- 13.1 Communication error between outdoor unit - 14.2 Outdoor unit network communication 2 error - 14.5 The number of indoor unit shortage (*2) - 61.5 Outdoor unit reverse phase, missing phase wire error - 69.1 Outdoor unit transmission PCB parallel communication error - 9A.1 Coil1 (Expansion valve1) error - 9A.2 Coil2 (Expansion valve2) error - 9A.3 Coil3 (Expansion valve3) error - A5.1 Low pressure abnormal (*3)

(*1) This will not be displayed on indoor unit which Error Report Target (function setting 47 of indoor unit) is set "for administrator".

(*2) The System condition can change to ① (Trouble Level 1) by changing DIP SW (SET 4-1:OFF)

(*3) Even if power is reset, this Error cannot release. In Error release, you need to solving the problem and operate the push switch and a and apply "Error reset" (F3-40) after power restart.

(*4)

<< Error code which manual error release will be required >>

- A5.1 Low pressure abnormal
- 84.1 Current sensor 1 error
- 93.1 Inverter compressor start up error
- 94.1 Trip detection
- A1.1 Discharge temperature 1 abnormal
- A3.1 Compressor 1 temperature abnormal
- 97.1 Outdoor unit fan motor lock error
- 97.5 Fan motor temperature abnormal
- 97.9 Fan motor driver abnormal
- 68.2 Rush current limiting resister temp rise protection
- 95.5 Compressor motor loss of synchronization
- A6.3 Outdoor heat exchanger 1 gas temperature abnormal
- A6.4 Outdoor heat exchanger 2 gas temperature abnormal

4-2-8 ERROR HISTORY MODE

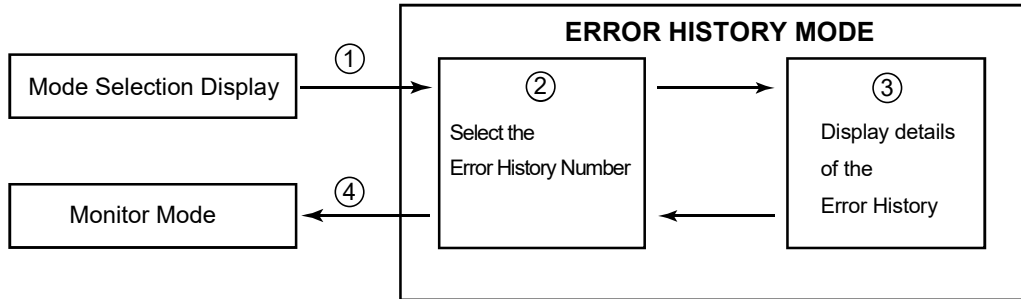

① Change to the Error History Mode from the Mode Selection Display

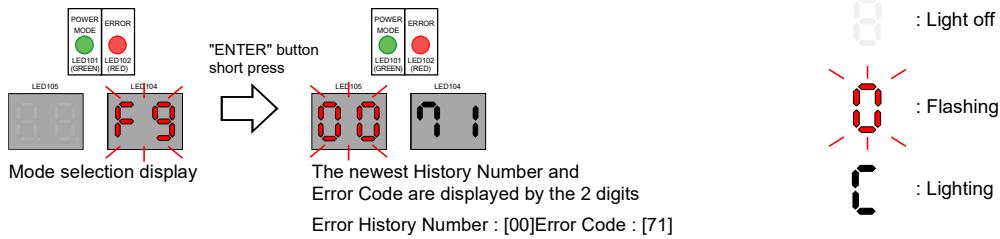

② Select the Error History Number

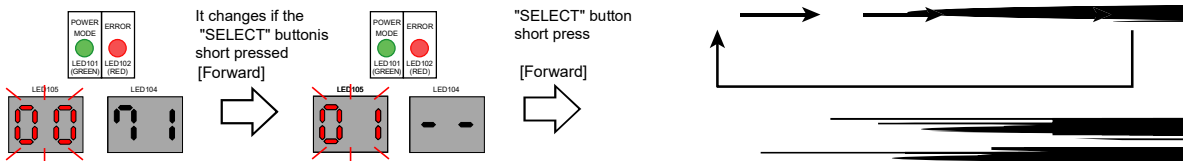

③ Check the detail of the Error History

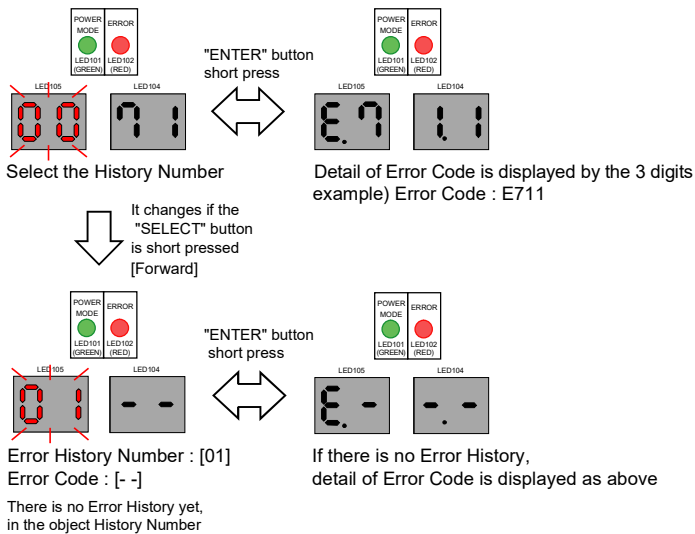

④ End of the Error History mode

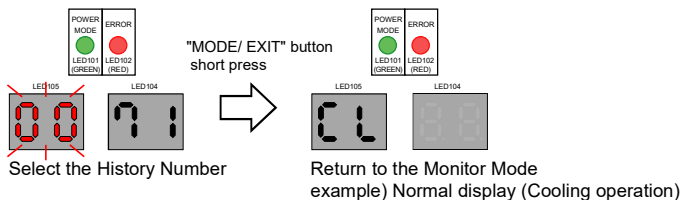

4-2-9 TROUBLE SHOOTING WITH ERROR CODE

Trouble shooting 1 INDOOR UNIT Error Method: Wired Remote Controller Communication Error	E12.1	Indicate or Display: Outdoor Unit : E.5 U.1 Indoor Unit : Operation LED 1 times Flash, Timer LED 2 Times Flash, Filter LED Continuous Flash. < 1 2 > Error Code : 1 2
---	--------------	--

Detective Actuators: Indoor unit controller PCB circuit Wired Remote Control (3 wire / 2 Wire type)	Detective details: Upon receiving the signal more than 1 time from Wired Remote or other Indoor unit, but the same signal has not been received more than 1 minute (3 Wire type). 2.5 minute (2 Wire type)
--	--

Forecast of Cause : 1. Terminal connection abnormal 2. Wired Remote Control failure 3. Controller PCB failure

Check Point 1 : Check the connection of terminal

After turning off the power, check & correct the followings.

Indoor Unit - Check the connection of terminal between remote control and Indoor unit, or between Indoor units, and check if there is a disconnection or short of the cable.



Check Point 2 : Check Remote and Controller PCB

Check terminal voltage of controller PCB Connector CNC01. (Power supply for Remote)

If DC12V, Remote Control failure (Controller PCB is OK) >>> Replace Remote controller

If DC0V, Controller PCB failure (Remote is OK) >>> Replace Controller PCB

▶ In case of re-installation is done due to removed connector or incorrect wiring, turn on the power again.

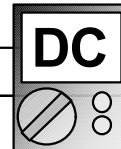

Trouble shooting 2 INDOOR UNIT Error Method: Wired Remote Controller signal Error	E12.2 Indicate or Display: Outdoor Unit : E.5 U.1, Indoor Unit : Operation LED 1 times Flash, Timer LED 2 Times Flash, Filter LED Continuous Flash. Remote Controller : 1 2
--	--

Detective Actuators: Indoor unit Controller PCB circuit Wired Remote Control (3 wire type)	Detective details: More than 1 time of Token (Communication between wired remote controllers) is received, but it was not received more than 1 minute.
---	--

Forecast of Cause : 1. Terminal connection abnormal 2. Mis-setting 3. Wired Remote Control failure 4. Controller PCB failure

Check Point 1 : Check the connection of terminal

After turning off the power, check & correct the followings.

- Indoor Unit - Check the connection of terminal between remote control and Indoor unit, or between Indoor units, and check if there is a disconnection or short of the cable.



Check Point 2 : Check Remote and Controller PCB

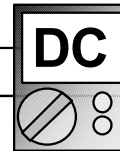

- Check terminal voltage of Controller PCB Connector CNC01. (Power supply for Remote)
 - If DC12V, Remote Control failure (Controller PCB is OK) >>> Replace Remote
 - If DC0V, Controller PCB failure (Remote is OK) >>> Replace Controller PCB

▶ In case of re-installation is done due to removed connector or incorrect wiring, turn on the power again.

Trouble shooting 3 E12.3 INDOOR UNIT Error Method: Number excess of device in Wired remote controller system (2 Wires RC)	Indicate or Display: Outdoor Unit : E.5 U.1 Indoor Unit : Operation LED 1 times Flash, Timer LED 2 Times Flash, Filter LED Continuous Flash. Error Code : 1 2
--	---

Detective Actuators: Wired remote controller (2-Wire) Indoor unit Controller PCB circuit	Detective details: When the number of connecting Indoor unit and Remote controller in one RCgroup exceeds more than 32 units.
---	---

Forecast of Cause : 1. Wrong wiring of RCgroup 2. Indoor unit controller PCB failure

Check Point 1 : Wire installation Wrong RCgroup setting
<input type="checkbox"/> Wrong wire connection in RCgroup (Please refer to the installation manual) <input type="checkbox"/> The number of connecting indoor unit and Remote controller in one RCgroup were less than 32 units.



Check Point 2 : Check Indoor unit controller PCB
<input type="checkbox"/> Check if controller PCB damage <input type="checkbox"/> Change controller PCB and check the Error after setting remote controller address

Trouble shooting 4 E1 3. 1 OUTDOOR UNIT Error Method: Communication Error Between Outdoor unit	Indicate or Display: Outdoor Unit : E. 1 3. 1 Indoor Unit : Operation LED 9 times Flash, Timer LED 15 Times Flash, Filter LED Continuous Flash. Error Code : 9 U / 1 3
--	---

Detective Actuators: Outdoor unit Main PCB	Detective details: Master unit: State in which "number of connected slave units" by Dip-SW and the number of slave units which can be recognized by communication did not match continued for 10 seconds or more after the start of control. Slave unit: State in which communication from the master unit was not received continued for 10 seconds or more after the start of control.
--	---

Forecast of Cause : 1. Noise, momentary open, voltage drop 3. The number setting mistake of outdoor unit 4. Connection of communication lines between outdoor units defective	2. Power supply defective 5. Main PCB defective
--	--

Check Point 1 : Noise, momentary open, voltage drop
<input type="checkbox"/> Check if temporary voltage drop was not generated. <input type="checkbox"/> Check if momentary open was not generated. <input type="checkbox"/> Check if ground is connection correctly or there are no related cables near the power line.

↓ **OK**

Check Point 2 : Check the power supply
<input type="checkbox"/> Main power ON/OFF state check <input type="checkbox"/> Power cable connection, open check

↓ **OK**

Check Point 3 : Check the number setting of outdoor units												
<input type="checkbox"/> Check the number setting of outdoor units.												
<table border="1" style="margin-left: auto; margin-right: auto;"> <thead> <tr> <th style="text-align: left;">Number of outdoor unit</th> <th style="text-align: center;">DIP-SW SET 5-1</th> <th style="text-align: center;">DIP-SW SET 5-2</th> </tr> </thead> <tbody> <tr> <td style="text-align: center;">1 unit</td> <td style="text-align: center;">OFF</td> <td style="text-align: center;">OFF</td> </tr> <tr> <td style="text-align: center;">2 units</td> <td style="text-align: center;">OFF</td> <td style="text-align: center;">ON</td> </tr> <tr> <td style="text-align: center;">3 units</td> <td style="text-align: center;">ON</td> <td style="text-align: center;">OFF</td> </tr> </tbody> </table>	Number of outdoor unit	DIP-SW SET 5-1	DIP-SW SET 5-2	1 unit	OFF	OFF	2 units	OFF	ON	3 units	ON	OFF
Number of outdoor unit	DIP-SW SET 5-1	DIP-SW SET 5-2										
1 unit	OFF	OFF										
2 units	OFF	ON										
3 units	ON	OFF										

↓ **OK**

Check Point 4 : Check the connection of communication lines between outdoor units
Turn off the power and check. <input type="checkbox"/> Connection and open check of communication lines between outdoor units.

↓ **OK**

Check Point 5 : Replace Main PCB
<input type="checkbox"/> Change Main PCB and set up the original address.

Trouble shooting 5 E14.1 OUTDOOR UNIT Error Method: Outdoor Unit Network Communication 1 Error	Indicate or Display: Outdoor Unit : E. 1 4. 1 Indoor Unit : No display / Operation LED 1 times Flash, Timer LED 4 Times Flash, Filter LED Continuous Flash. Error Code : 1 4 / 1 6 / 1 4. 1 / 1 4. 3 *
--	---

* Indoor unit indicates No display or 1 4
Peripheral device indicates 1 4 or 16.

Detective Actuators: Outdoor unit Main PCB	Detective details: <ul style="list-style-type: none"> ▪DIP-SW SET4-1 is OFF. ▪No communication for 180 seconds or more from an indoor unit which received communication once and no Outdoor unit network communication 2 error.
--	---

Forecast of Cause : 1. Noise, momentary open, voltage drop 2. Indoor unit or RB unit power off
3. Communication line connection defective 4. Terminal resistor setting mistake
5. Communication PCB mounting defective, Communication PCB defective 6. Controller PCB defective

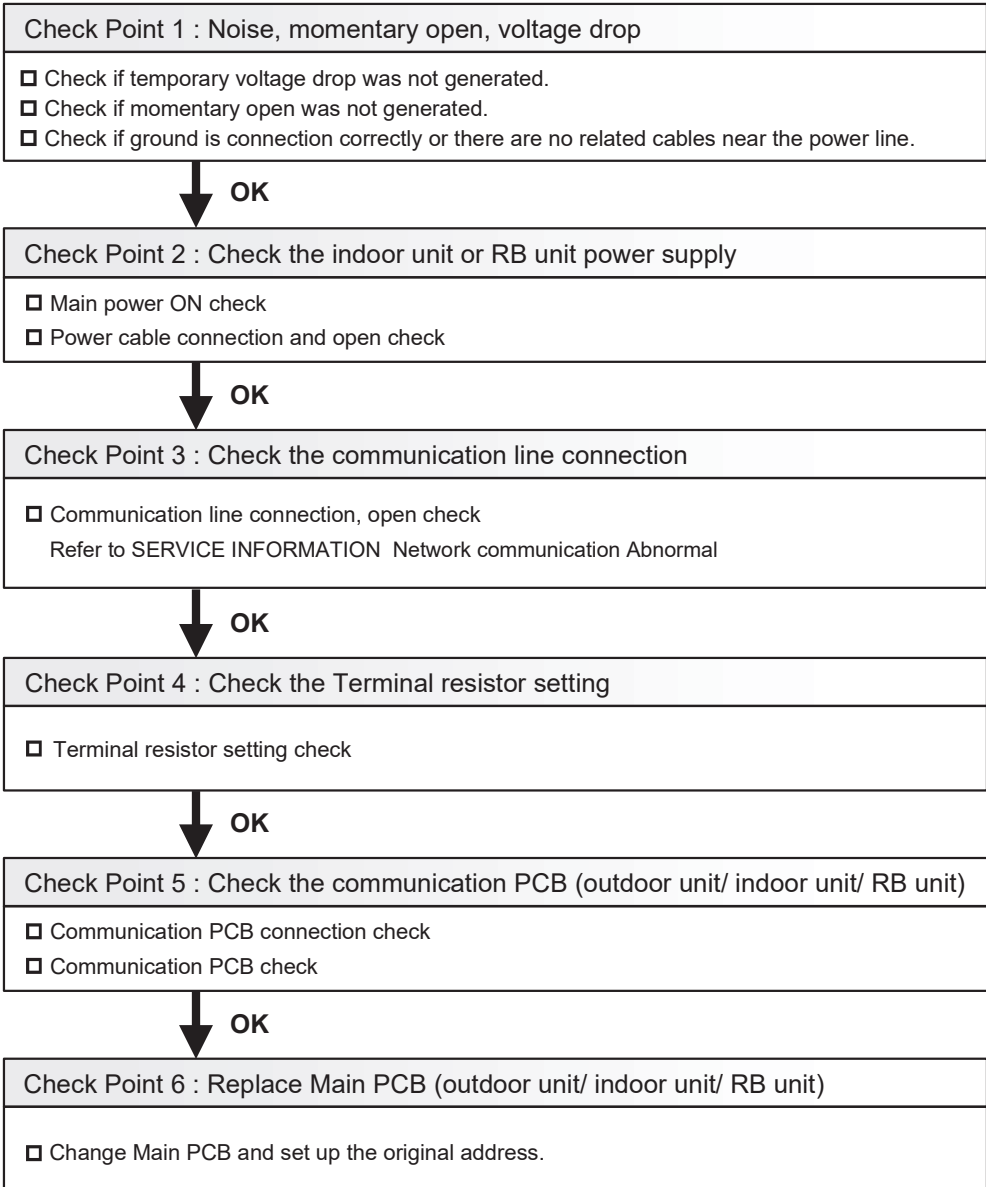

Trouble shooting 6 E14. 2 OUTDOOR UNIT Error Method : Outdoor Unit Network Communication 2 Error	Indicate or Display: Outdoor Unit : E. 1 4. 2 Indoor Unit : Operation LED 9 times Flash, Timer LED 15 Times Flash, Filter LED Continuous Flash. / Operation LED 1 times Flash, Timer LED 4 Times Flash, Filter LED Continuous Flash. * Error Code : 9 U / 1 4 / 1 6 / 1 4. 1 / 1 4. 2 / 1 4. 3 *
--	--

* Indoor unit indicates 9 U or 1 4
Peripheral device indicates 1 4 or 1 6

Detective Actuators: Outdoor unit Main PCB	Detective details: [DIP-SW SET4-1 : ON] (Factory setting) •No communication for 180 seconds or more from an indoor unit which received communication once. [DIP-SW SET4-1 : OFF] •No communication for 180 seconds or more from all indoor units that once received communication.
--	---

Forecast of Cause : 1. Noise, momentary open, voltage drop 2. Indoor unit or RB unit power off
3. Communication line connection defective 4. Terminal resistor setting mistake
5. Communication PCB mounting defective, Communication PCB defective 6. Control PCB defective

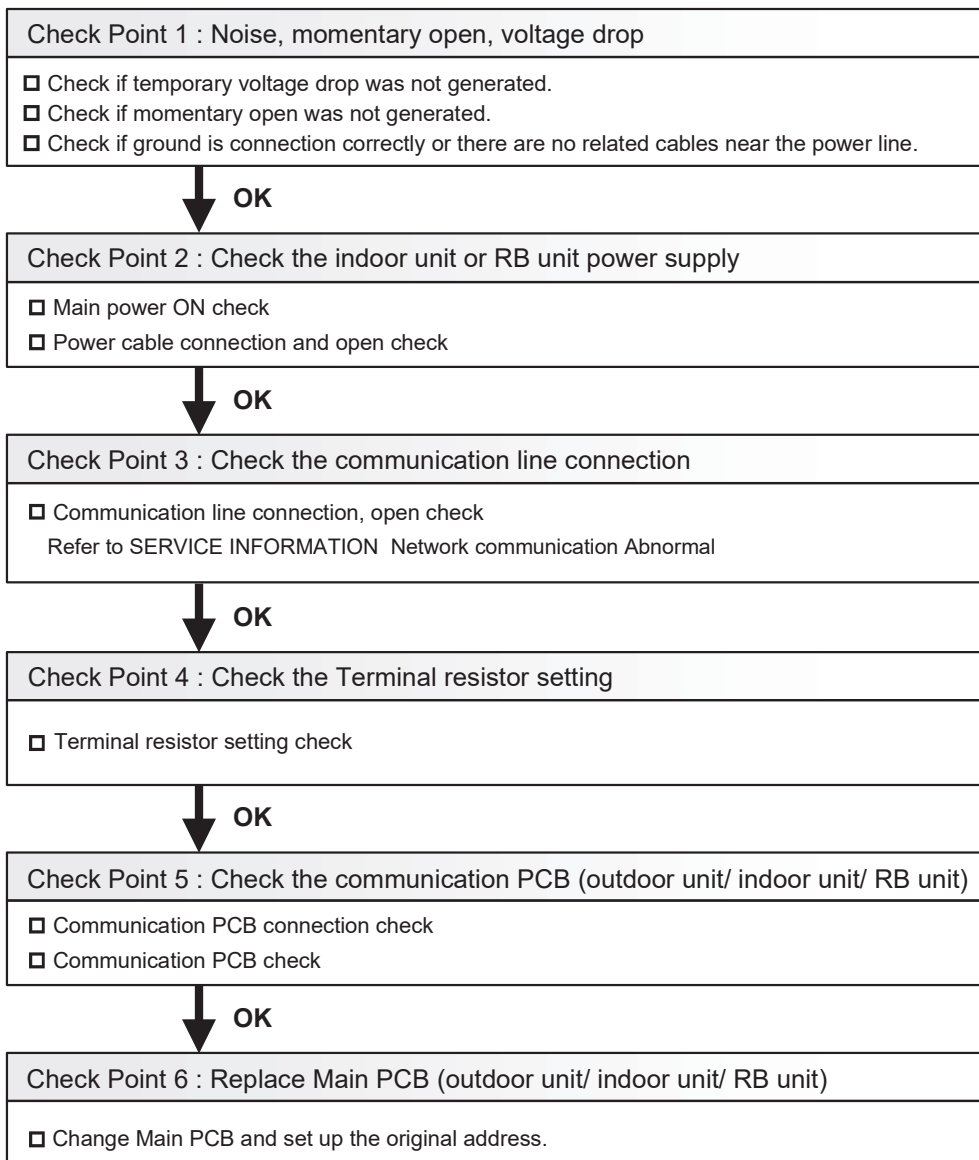

Trouble shooting 7	E14. 3	Indicate or Display:
INDOOR UNIT Error Method:		Outdoor Unit : E.1 4. 1 / 1 4. 2 *
Indoor unit Network communication Error		Indoor Unit : Operation LED 1 times Flash, Timer LED 4 Times Flash, Filter LED Continuous Flash.
		Error Code : 1 4 / 1 6 / 9 U / 14.1 / 14.2 / 14.3 *

* Outdoor unit indicates 1 4.1 or 1 4.2 (No communication from 14.3 Error Indoor unit)
Peripheral device indicates 1 4 or 1 6

Detective Actuators:	Detective details:
Indoor unit Controller PCB circuit Indoor unit Communication PCB	When the cut-off of network communication is detected (more than 90 seconds passed since the last receipt of Outdoor unit signal).

Forecast of Cause : 1. Outside cause 2. Connection failure 3. Communication PCB failure 4. Controller PCB failure

Check Point 1 : Check if any outside cause such as voltage drop or noise

- ⚙ Instant voltage drop ----- Check if there is any electric equipment with a large load within the same circuit.
- ⚙ Momentary power failure ----- Check contact failure or leak current in power supply circuit
>>Check power supply for RB unit and Outdoor Unit as well.
- ⚙ Check if there is any equipment that causes harmonic wave near the power cable (Neon light bulb or any electronic equipment which causes harmonic wave). And check the complete insulation of grounding.
>>If the same symptom does not reappear after resetting the power, possibility of noise is high.



Check Point 2 : Check the connection

After turning off the power, check and correct followings.

- Is Indoor Communication PCB loose?
- Check loose or removed connection of communication line Indoor unit => RB unit => Outdoor unit.
Refer to SERVICE INFORMATION Network communication Abnormal
- Check the Error indication of RB unit.
Refer to SERVICE INFORMATION RB Unit Abnormal
- When the signal amplifier is connected, Check the error indication of signal amplifier. (Refer to the installation manual)



Check Point 3 : Check Communication PCB

- Replace Communication PCB of the Indoor units that have the error.
- If still the error is there, replace the communication PCB of the RB unit which corresponds to the error indicating Indoor unit.



Check Point 4 : Check Controller PCB

- Replace controller PCB of the Indoor units that have the error.
- If still the error is there, replace the controller PCB of the RB unit which corresponds to the error indicating Indoor unit.

Trouble shooting 8 E14. 5 OUTDOOR UNIT Error Method: The number of Indoor unit shortage Error	Indicate or Display: Outdoor Unit : E.1 4. 5 Indoor Unit : Operation LED 9 times Flash, Timer LED 15 Times Flash, Filter LED Continuous Flash. / No display (When DIP-SW4-1 is OFF.) Error Code : 9 U / 1 4 / 1 6 / 1 4. 5 / 1 4. 3 *
---	--

*Peripheral device indicates 14,16

Detective Actuators: Outdoor unit Main PCB	Detective details: When the indoor unit number decreases for 180 seconds from the memorized maximum indoor units number after power(Breaker) ON.
--	--

Forecast of Cause :	1. Indoor unit or RB unit power off 2. Noise, momentary open, voltage drop 3. Communication line connection defective 4. Terminal resistor setting mistake 5. Communication PCB mounting defective, Communication PCB defective 6. Controller PCB defective
----------------------------	--

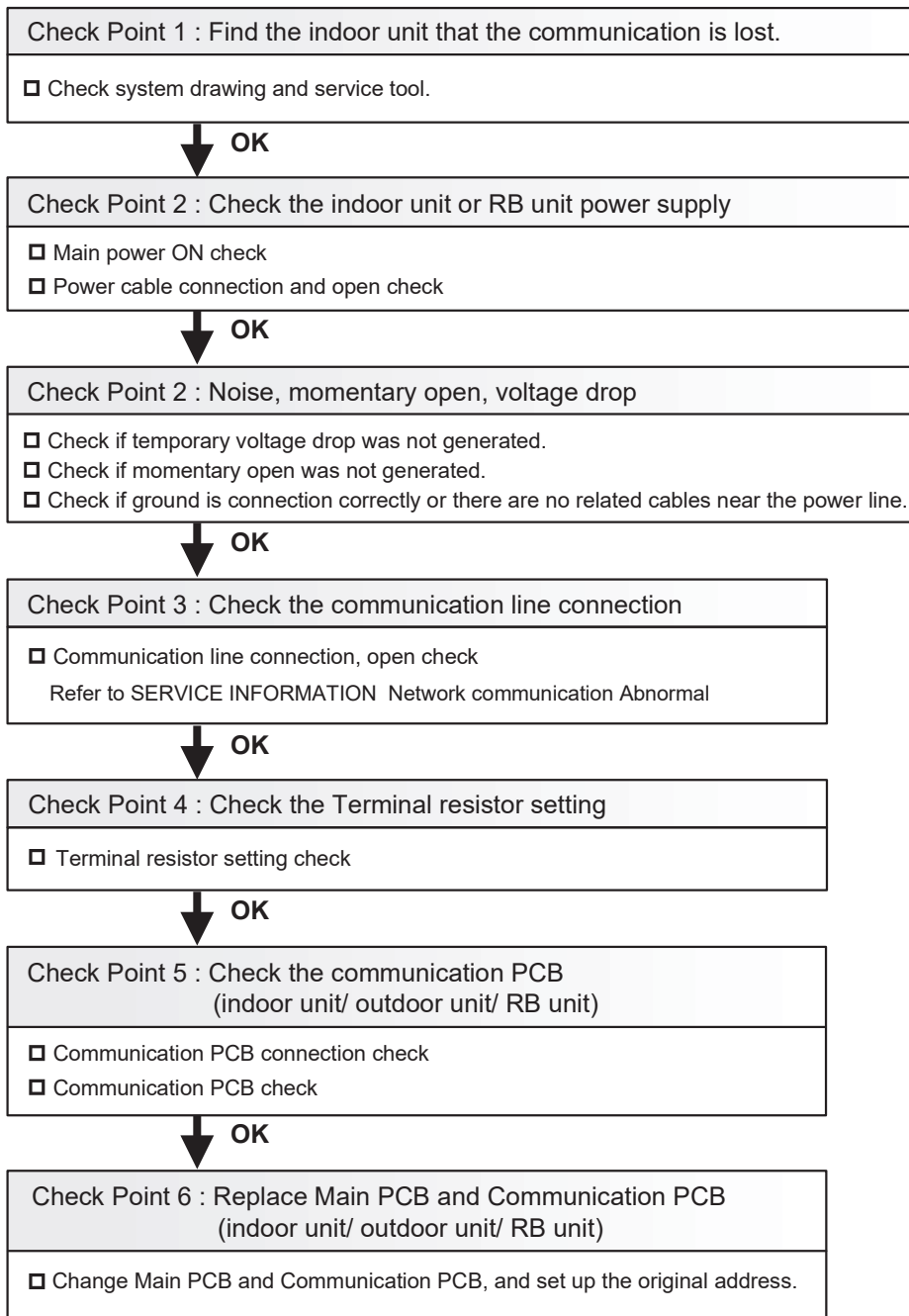

Attention!!

In case of DIP-SW SET4-1 is ON(factory setting), If this error occurs, system stops. In case of DIP-SW SET4-1 is OFF, If this error occurs, system does not stop.

If the failure indoor unit is pinpointed and it needs to erase the error indication, it can be reset by function setting (F3-41: Maximum memorized indoor unit number reset).

Caution!!

Even if normal, this error occurs temporarily by the timing of the power ON of outdoor unit, indoor unit, RB unit, and signal amplifier.

In this case, please wait for 5 minutes after turning on all the equipments.

Trouble shooting 9 E16. 1 INDOOR UNIT Error Method: Transmission PCB Connection Error	Indicate or Display: Outdoor Unit : E.1 4.1, 1 4.2 * Indoor Unit : Operation LED 1 times Flash, Timer LED 6 Times Flash, Filter LED Continuous Flash. Error Code : 1 6 *
---	---

* Outdoor unit indicates 1 4.1 or 14.2 (No communication from Indoor unit)
Peripheral device indicates 1 6 (1 6.4 Error)
Service Tool indicates 14.3 (Missing Error Indoor unit)

Detective Actuators: Indoor unit Controller PCB circuit Indoor unit Communication PCB	Detective details: When Parallel communication error (Communication reset occurs continuously more than specified times) is detected.
--	---

Forecast of Cause : 1. Connection failure 2. Outside cause 3. Communication PCB failure 4. Controller PCB failure

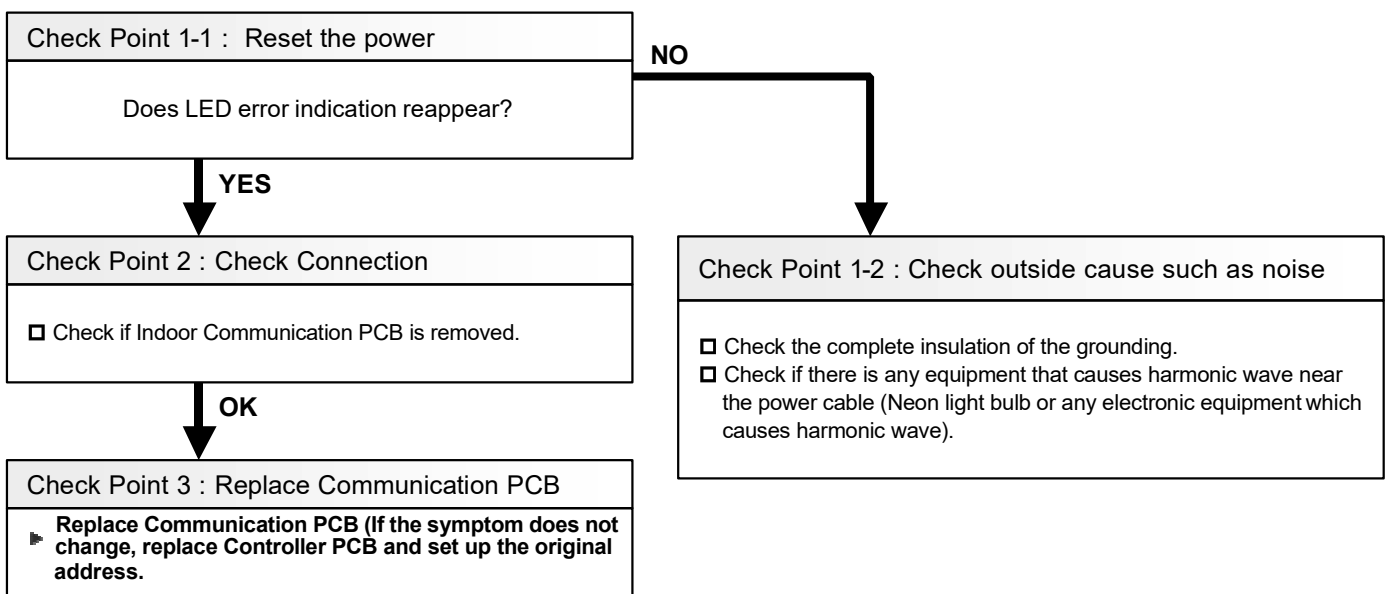

Trouble shooting 10 INDOOR UNIT Error Method: Communication Error Between Controller and Indoor unit	E16. 4	Indicate or Display: Outdoor Unit : No Display Indoor Unit : No Display Error Code : 1 6 (Peripheral Unit)
---	---------------	--

<u>Detective Actuators:</u> Indoor unit Controller PCB circuit Indoor unit Communication PCB	<u>Detective details:</u> When the cut-off of network communication is detected (more than 90 seconds passed since the last receipt of Outdoor unit signal).
---	--

Forecast of Cause : 1. Outside cause 2.Connection failure 3. Communication PCB failure 4. Controller PCB failure

Check Point 1 : Check if any outside cause such as voltage drop or noise

- Instant voltage drop ----- Check if there is any electric equipment with a large load within the same circuit.
- Momentary power failure ----- Check contact failure or leak current in power supply circuit
>>Check power supply for RB unit and Outdoor Unit as well.
- Check if there is any equipment that causes harmonic wave near the power cable (Neon light bulb or any electronic equipment which causes harmonic wave). And check the complete insulation of grounding.
>>If the same symptom does not reappear after resetting the power, possibility of noise is high.



Check Point 2 : Check the connection

After turning off the power, check and correct followings.

- Is Indoor Communication PCB loose?
- Check loose or removed connection of communication line Indoor unit => RB unit => Outdoor unit.
Refer to the Service Information -Network Abnormal -
- Check the Error indication of RB unit. (Refer to the Trouble shooting 69, 70)
- When the signal amplifier is connected , Check the error indication of signal amplifier - Refer to the Installation manual-



Check Point 3 : Check Communication PCB

- Replace Communication PCB of the Indoor units that have the error.
- If still the error is there, replace the communication PCB of the RB unit which corresponds to the error indicating Indoor unit.



Check Point 4 : Check Controller PCB

- Replace controller PCB of the Indoor units that have the error.
- If still the error is there, replace the controller PCB of the RB unit which corresponds to the error indicating Indoor unit.

Trouble shooting 11 E26. 4 INDOOR UNIT Error Method: Address Duplication in Wired remote controller system	Indicate or Display: Outdoor Unit : E.5 U.1 Indoor Unit : Operation LED 2 times Flash, Timer LED 6 Times Flash, Filter LED Continuous Flash. Error Code : 2 6
--	--

Detective Actuators: Wired remote controller (2-Wire) Indoor unit Controller PCB circuit	Detective details: When the duplicated address number exists in one RCgroup
---	---

Forecast of Cause : 1. Wrong wiring of RCgroup 2. Wrong remote address setting 3. Indoor unit controller PCB failure
4. Remote controller failure

Check Point 1 : Wire installation
<input type="checkbox"/> Wrong wire connection in RCgroup (Please refer to the installation manual)



Check Point 2 : Wrong RCgroup setting
<input type="checkbox"/> The duplicated address number is not existing in one RCgroup



Check Point 3 : Check Indoor unit controller PCB
<input type="checkbox"/> Check if controller PCB damage <input type="checkbox"/> Change controller PCB and check the Error after setting remote controller address

Trouble shooting 12 E26. 5 INDOOR UNIT Error Method: Address setting Error in Wired remote controller system	<u>Indicate or Display:</u> Outdoor Unit : E.5 U.1 Indoor Unit : Operation LED 2 times Flash, Timer LED 6 Times Flash, Filter LED Continuous Flash. Error Code : 2 6
--	---

Detective Actuators: Wired remote controller (2-Wire) Indoor unit Controller PCB circuit	Detective details: When the address number set by auto setting and manual setting are mixed in one RC group
---	---

Forecast of Cause : 1. Wrong wiring of RCgroup 2. Wrong remote address setting 3. Indoor unit controller PCB failure
4. Remote controller failure

Check Point 1 : Wire installation

- Wrong wire connection in RCgroup (Please refer to the installation manual)



Check Point 2 : Wrong RCgroup setting

- The given address number by auto setting (00) and the manual set number (Except 00) were not existing in one RCG.
- The remote controller address setting by U.I. were not existing same address.



Check Point 3 : Check Indoor unit controller PCB

- Check if controller PCB damage
- Change controller PCB and check the Error after setting remote controller address

Trouble shooting 13 E28. 1 OUTDOOR UNIT Error Method: Auto Address Setting Error	Indicate or Display: Outdoor Unit : E. 28. 1 Indoor Unit : No Display Error Code : No Display * Service tool does not indicate the Error code
--	--

<< After Indoor unit Auto Adress setting >>

<u>Detective Actuators:</u> Outdoor unit Main PCB	<u>Detective details:</u> <ul style="list-style-type: none"> ▪ When none of the connected indoor units answers during auto address And when abnormal answer signal is input.
---	--

<u>Forecast of Cause :</u>	1. Indoor unit power supply defective 2. Indoor unit overconnected 3.Communication line incorrect connection 4. Noise, momentary open
-----------------------------------	--

Check Point 1 : Check the indoor unit power supply <input type="checkbox"/> Check the indoor unit power supply



Check Point 2 : Check the indoor unit number connection <input type="checkbox"/> Check if more than 64 indoor units are connected in a refrigerant circuit



Check Point 3 : Check the communication line connection Check if communication line is correctly connected <input type="checkbox"/> Is it uncoupled or cut halfway ? <input type="checkbox"/> Connecting terminal position is correct as the installation manual shows ?



Check Point 4 : Check noise, momentary open, voltage drop <input type="checkbox"/> Check if power supply temporarily stops by outages or if strong noise is generated from surrounding environment during auto address

<< After RB unit Auto Adress setting >>

<u>Detective Actuators:</u> Outdoor unit Main PCB	<u>Detective details:</u> <ul style="list-style-type: none"> ▪ When there is except 0~63 (64 or more) in the indoor unit address of the indoor unit connected to RB unit. ▪ When the address memorized to RB unit was incorrectly value.
---	--

<u>Forecast of Cause :</u>	1. Indoor unit address setting error 2. RB unit controller PCB defective
-----------------------------------	---

Check Point 1 : Check the indoor unit address setting <input type="checkbox"/> Check the indoor unit address.
--



Check Point 2 : Replace RB unit controller PCB <input type="checkbox"/> Replace RB unit controller PCB.
--

Trouble shooting 14	E28. 4	Indicate or Display:	
OUTDOOR UNIT Error Method:		Outdoor Unit : E. 2 8. 4	
Signal Amplifier Auto Address Error		Indoor Unit : No Display	
		Error Code : No Display	*Service tool does not indicate the Error

Detective Actuators:	Detective details:
Outdoor unit Main PCB	▪ When abnormal answer signal is input during signal amplifier auto address

Forecast of Cause :	1. Signal amplifier power supply defective	2. Signal amplifier overconnected
	3. Signal amplifier auto address wrong setting	4. Noise, momentary open.

Check Point 1 : Check signal amplifier unit power supply

Check signal amplifier unit power supply



Check Point 2 : Check the signal amplifier number connection

Check if more than 8 signal amplifiers (filter mode = off) are connected in a network.

Check if more than 32 signal amplifiers (filter mode = on) are connected in a network.



Check Point 3 : Check the operation of signal amplifier auto address setting

Check if signal amplifier auto address is set at the same time from multiple outdoor units (master unit)



Check Point 4 : Check noise, momentary open, voltage drop

Check if power supply temporarily stops by outages or if strong noise is generated from surrounding environment during signal amplifier auto address

Trouble shooting 15 E29. 1 INDOOR UNIT Error Method: Connection unit number error (Indoor unit in Wired remote controller system)	Indicate or Display: Outdoor Unit : E.5 U.1 Indoor Unit : Operation LED 2 times Flash, Timer LED 9 Times Flash, Filter LED Continuous Flash. Error Code : 2 9
---	--

Detective Actuators: Wired remote controller (2-Wire) Indoor unit Controller PCB circuit	Detective details: When the number of connecting indoor units are out of specified rule.
---	--

Forecast of Cause : 1. Wrong wiring/ Number of I.U, RC in RCgroup 2. Indoor unit controller PCB defective

Check Point 1 : Wire installation
<input type="checkbox"/> Wrong number of connecting indoor unit



Check Point 2 : Check Indoor unit controller PCB
<input type="checkbox"/> Check if controller PCB damage <input type="checkbox"/> Change controller PCB and check the Error after setting remote controller address

Trouble shooting 16 INDOOR UNIT Error Method: Connection unit number error (Remote controller)	E29. 2 Indicate or Display: Outdoor Unit : No Display Indoor Unit : No Display Error Code : 2 9
---	--

Detective Actuators: Wired remote controller (2-Wire)	Detective details: When the number of connecting remote controller are out of specified rule.
---	---

Forecast of Cause : 1. Wrong wiring / Wrong number of connecting RC in RCgroup 2. Remote controller PCB defective

Check Point 1 : Wire installation
<input type="checkbox"/> Wrong number of connecting remote controller



Check Point 2 : Check Indoor unit controller PCB
<input type="checkbox"/> Check if controller PCB damage <input type="checkbox"/> Change controller PCB and check the Error after setting remote controller address

Trouble shooting 17	E31. 3	Indicate or Display: Outdoor Unit : E.5 U.1 Indoor Unit : Operation LED 3 times Flash, Timer LED 1 Times Flash, Filter LED Continuous Flash. Error Code : 3 1
----------------------------	---------------	--

Detective Actuators: Indoor Unit Controller PCB Circuit	Detective details: When 5 continuous failures occurred at Power frequency test.
---	---

Forecast of Cause : 1. Outside cause 2. Installation failure 3. Defective connection of electric components
4. Controller PCB defective

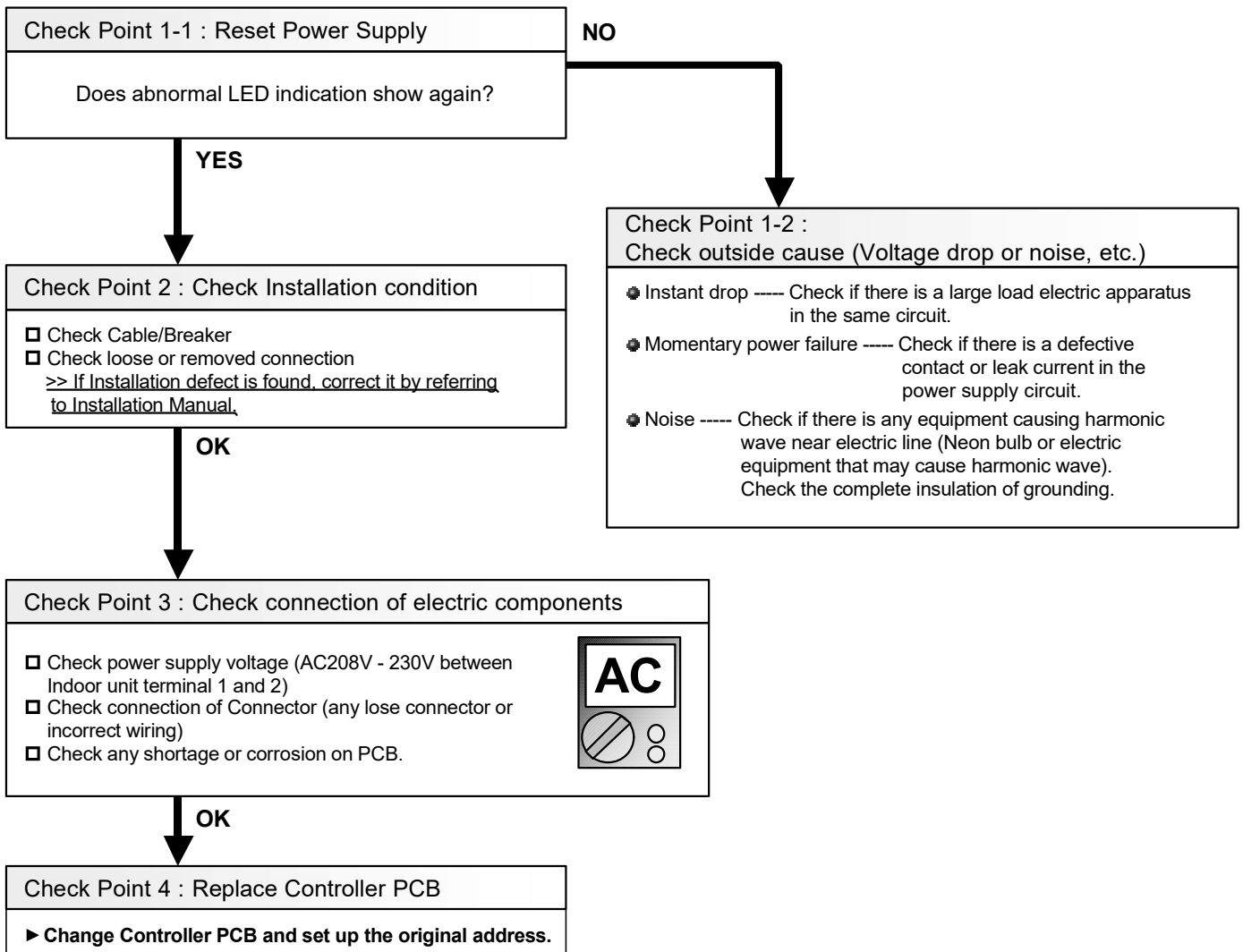

Trouble shooting 18	E32. 1	Indicate or Display:
INDOOR UNIT Error Method:		Outdoor Unit : E.5 U.1
Indoor unit PCB Model Information Error		Indoor Unit : Operation LED 3 times Flash, Timer LED 2 Times Flash, Filter LED Continuous Flash.
		Error Code : 3 2

Detective Actuators:	Detective details:
Indoor Unit Controller PCB Circuit	3 continuous failure of lead test of EEPROM at Power ON, or Apparent Model information error from EEPROM. Also, Error on Model information upon model information test of EEPROM, or Model information of EEPROM not possible to recover.

Forecast of Cause : 1. Outside cause 2. Connection failure of electric components 3. Controller PCB defective

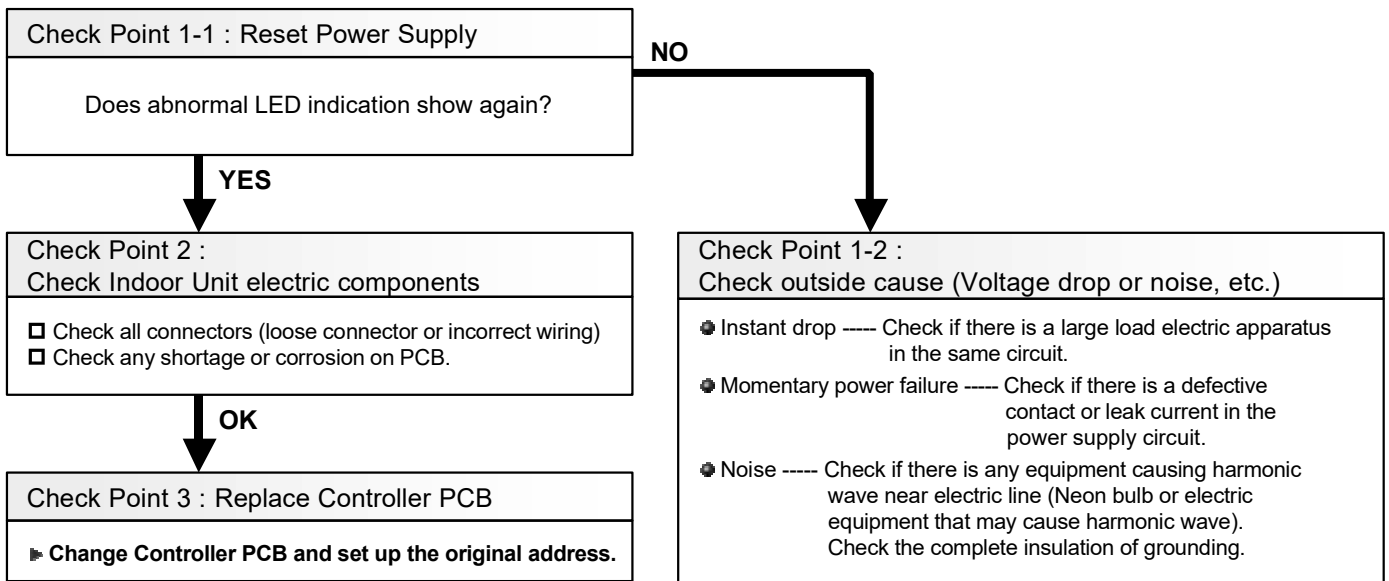

Note : EEPROM
EEPROM(Electronically Erasable and Programmable Read Only Memory) is a non-volatile memory which keeps memorized information even if power is turned off. It can change the contents electronically. To change the contents, it uses higher voltage than normal, and it can not change a partial contents. (Rewriting shall be done upon erasing the all contents.) There is a limit in a number of rewriting.

Trouble shooting 19 INDOOR UNIT Error Method: Indoor unit EEPROM Access Error	E32. 3	Indicate or Display: Outdoor Unit : E.5 U.1 Indoor Unit : Operation LED 3 times Flash, Timer LED 2 Times Flash, Filter LED Continuous Flash. Error Code : 3 2
--	---------------	--

Detective Actuators: Indoor Unit Controller PCB Circuit	Detective details: When 3 continuous failure occurred on lead test of EEPROM.
---	---

Forecast of Cause : 1. Outside cause 2. Defective connection of electric component 3. Controller PCB defective

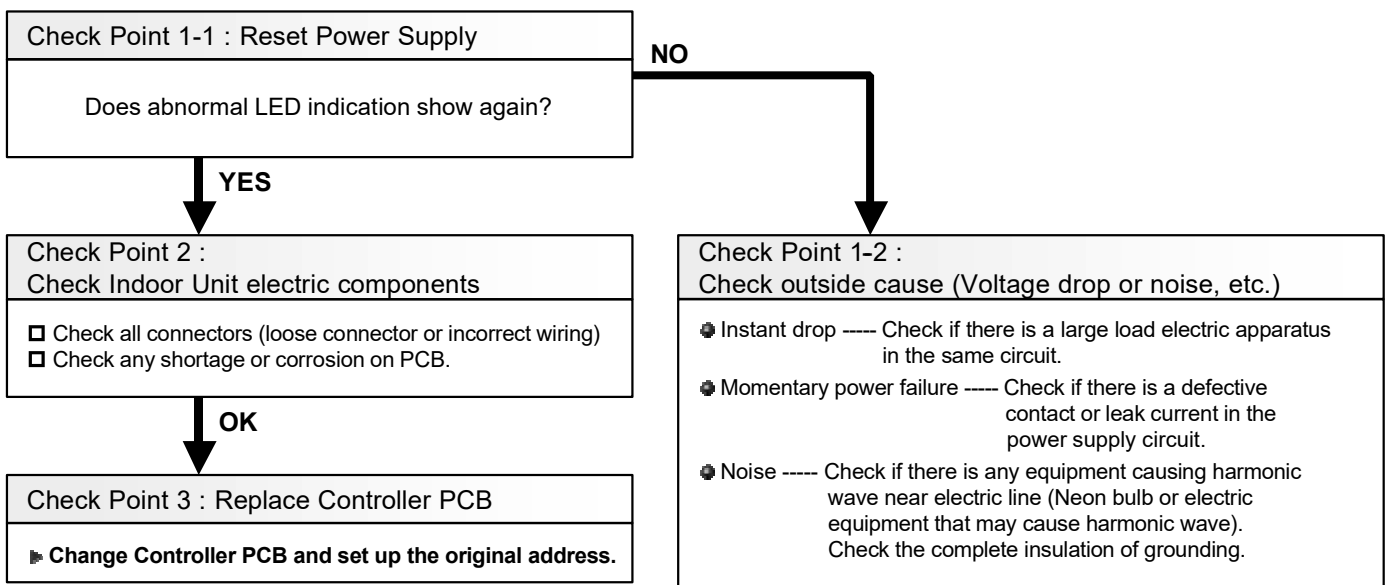

Trouble shooting 20 INDOOR UNIT Error Method: Indoor unit communication circuit (WRC) microcomputers communication Error	E3A. 1	Indicate or Display: Outdoor Unit : E.5 U.1 Indoor Unit : Operation LED 3 times Flash, Timer LED 10 Times Flash, Filter LED Continuous Flash. Error Code : 3 A
---	---------------	--

Detective Actuators: Wired remote controller (2-Wire) Indoor unit Controller PCB circuit	Detective details: When the indoor unit(s) detects the configuration of RCG abnormal or the indoor unit detects lack of primary -remote controller.
---	--

Forecast of Cause : 1. Terminal connection abnormal 2. Wired remote controller failure
 3. Indoor unit controller PCB defective

Check Point 1 : Check the connection of terminal

After turning off the power supply, check & correct the followings

- Indoor unit - Check the connection of terminal between remote control and indoor unit, or between Indoor units and check if there is a disconnection or short of the cable



Check Point 2 , 3: Check Indoor unit controller PCB

- Check terminal voltage of controller PCB connector CNC01 (Power supply for remote)
 - If DC12V, Remote control failure (Controller PCB is OK) >>> Replace Remote controller
 - If DC0V, Controller PCB failure (Remote is OK) >>> Replace Controller PCB

In case of re-installation is done due to removed connector or incorrect wiring, turn on the power again.

Trouble shooting 21 INDOOR UNIT Error Method: Inlet air temp. Sensor Error	E41. 1	Indicate or Display: Outdoor Unit : E.5 U.1 Indoor Unit : Operation LED 4 times Flash, Timer LED 1 Times Flash, Filter LED Continuous Flash.
		Error Code : 4 1

Detective Actuators: Indoor Unit Controller PCB Circuit Inlet air temp Sensor	Detective details: When Inlet air temp. sensor open or shortage is detected
--	---

Forecast of Cause : 1. Connector defective connection 2. Sensor defective 3. Controller PCB defective

Check Point 1 : Check connection of Connector

- Check if connector is loose or removed
- Check erroneous connection
- Check if sensor cable is open

>>Reset Power when reinstalling due to removed connector or incorrect wiring.



Check Point 2 : Remove connector and check Sensor resistance value

Sensor characteristics (Rough value)

Temperature (°F)	32	41	50	59	68	77	86	95
Temperature (°C)	0	5	10	15	20	25	30	35
Resistance Value (kΩ)	33.6	25.2	20.1	15.8	12.5	10.0	8.0	6.5

Temperature (°F)	104	113	122
Temperature (°C)	40	45	50
Resistance Value (kΩ)	5.3	4.3	3.5

▶ If Sensor is either open or shorted, replace it and reset the power.



Check Point 3 : Check voltage of Controller PCB (DC5.0V)

Corresponding connector

Model Type	Room temp. Sensor (Black Wires)
Duct type	CN8
Cassette type	
Compact Wall type	
Wall type	
Floor/Ceiling type	

▶ If the voltage does not appear, replace Controller PCB and set up the original address.

Trouble shooting 22	E42. 1	Indicate or Display: Outdoor Unit : E.5 U.1 Indoor Unit : Operation LED 4 times Flash, Timer LED 2 Times Flash, Filter LED Continuous Flash. Error Code : 4 2
----------------------------	---------------	--

Detective Actuators: Indoor Unit Controller PCB Circuit Heat Exchanger Inlet temp. Sensor	Detective details: When open or shorted Heat Exchanger Inlet temp. sensor is detected
--	---

Forecast of Cause : 1. Connector defective connection 2. Sensor defective 3. Controller PCB defective

Check Point 1 : Check connection of Connector
<input type="checkbox"/> Check if connector is loose or removed <input type="checkbox"/> Check erroneous connection <input type="checkbox"/> Check if thermistor cable is open <u>>>Reset Power when reinstalling due to removed connector or incorrect wiring.</u>

↓
OK

Check Point 2 : Remove connector and check sensor resistance value								
Sensor Characteristics (Rough value)								
Temperature (°F)	32	41	50	59	68	77	86	95
Temperature (°C)	0	5	10	15	20	25	30	35
Resistance Value (kΩ)	168.6	129.8	100.9	79.1	62.5	49.8	40.0	32.4
Temperature (°F)	104	113	122					
Temperature (°C)	40	45	50					
Resistance Value (kΩ)	26.3	21.2	17.8					
▶ If Thermistor is either open or shorted, replace it and reset the power.								

↓
OK

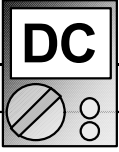
Check Point 3 : Check voltage of Controller PCB (DC5.0V)	
Corresponding connector	
Model Type	Heat Ex Inlet temp. Sensor (Black Wires)
Duct type	CN9
Cassette type	
Wall type	
Floor/Ceiling type	CN20
Compact Wall type	
▶ If the voltage does not appear, replace Controller PCB and set up the original address.	

Trouble shooting 23	E42. 3	Indicate or Display: Outdoor Unit : E.5 U.1 Indoor Unit : Operation LED 4 times Flash, Timer LED 2 Times Flash, Filter LED Continuous Flash. Error Code : 4 2
INDOOR UNIT Error Method: Indoor unit Heat Ex. outlet temp. Sensor Error		

Detective Actuators: Indoor Unit Controller PCB Circuit Heat Exchanger Outlet Temp. Sensor	Detective details: When open or shorted Heat Exchanger outlet temp. sensor is detected
---	--

Forecast of Cause : 1. Connector defective connection 2.Sensor defective 3.Controller PCB defective

Check Point 1 : Check connection of Connector

- Check if connector is loose or removed
- Check erroneous connection
- Check if Sensor cable is open

>>Reset Power when reinstalling due to removed connector or incorrect wiring.



Check Point 2 : Remove connector and check Sensor resistance value									
Sensor characteristics (Rough value)									
Temperature (°F)	32	41	50	59	68	77	86	95	
Temperature (°C)	0	5	10	15	20	25	30	35	
Resistance Value (kΩ)	168.6	129.8	100.9	79.1	62.5	49.8	40.0	32.4	
Temperature (°F)	104	113	122						
Temperature (°C)	40	45	50						
Resistance Value (kΩ)	26.3	21.2	17.8						
► If Sensor is either open or shorted, replace it and reset the power.									

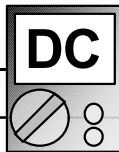
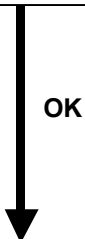

Check Point 3 : Check voltage of Controller PCB (DC5.0V)	
Corresponding connector	
Model Type	Heat Ex Outlet temp. Sensor (Gray Wires)
Duct type	CN9
Cassette type	
Wall type	
Floor/Ceiling type	
Compact Wall type	CN21
► If the voltage does not appear, replace Controller PCB and set up the original address.	

Trouble shooting 24 E51. 2 INDOOR UNIT Error Method: Indoor Unit Fan Motor 1 rotation speed Error	Indicate or Display: Outdoor Unit : E.5 U.1 Indoor Unit : Operation LED 5 times Flash, Timer LED 1 Times Flash, Filter LED Continuous Flash. Error Code : 5 1
---	--

Detective Actuators: Indoor Unit Controller PCB Circuit Indoor Fan Motor	Detective details: When the FAN motor feed back rotation value which is detecting on the controller PCB becomes 0 and lasts for more than 1 minute at motor operation condition. Or, when the feed back rotation value continues at 1/ 3 of target value for more than 1 minute.
---	---

Forecast of Cause : 1. Fan rotation failure 2. Fan motor winding open 3. Motor protection by ambient temp. increase
4. Capacitor failure 5. Controller PCB failure

Check Point 1 : Check rotation of Fan

Rotate the fan by hand when operation is off.
(Check if fan is caught, dropped off or locked motor)
>>If Fan or Bearing is abnormal, replace it.



Check Point 2 : Check Motor winding / Internal PCB circuit

Check Indoor Fan motor (Refer to the PARTS INFORMATION 20,21)
>>If Fan motor is abnormal, replace it.



Check Point 3 : Check ambient temp. around motor

Check excessively high temperature around the motor.
(If there is any surrounding equipment that causes heat)
>>Upon the temperature coming down, restart operation..



Check Point 4 : Check Motor Capacitor (*)

Check continuity of motor capacitor
>>If it is shorted, replace the capacitor.



* Applicable indoor unit:
- ARXA, ARCB, ARXC type



Check Point 5 : Replace Controller PCB

Change Controller PCB and set up the original address.

Trouble shooting 25 E52. 1 INDOOR UNIT Error Method: Coil 1 (Expansion valve) Error	Indicate or Display: Outdoor Unit : E.5U.1 Indoor Unit : Operation LED 5 times Flash, Timer LED 2 Times Flash, Filter LED Continuous Flash. Error Code : 5 2
--	---

Detective Actuators: Indoor unit controller PCB	Detective details: When the EEV1 drive circuit is open circuit
---	--

Forecast of Cause : 1. EEV1 coil lose connection 2. EEV1 wire(s) cut or pinched 3. Defective EEV1 coil 4. Controller PCB (DC 12V) output abnormal 5. Noise momentary open, voltage drop

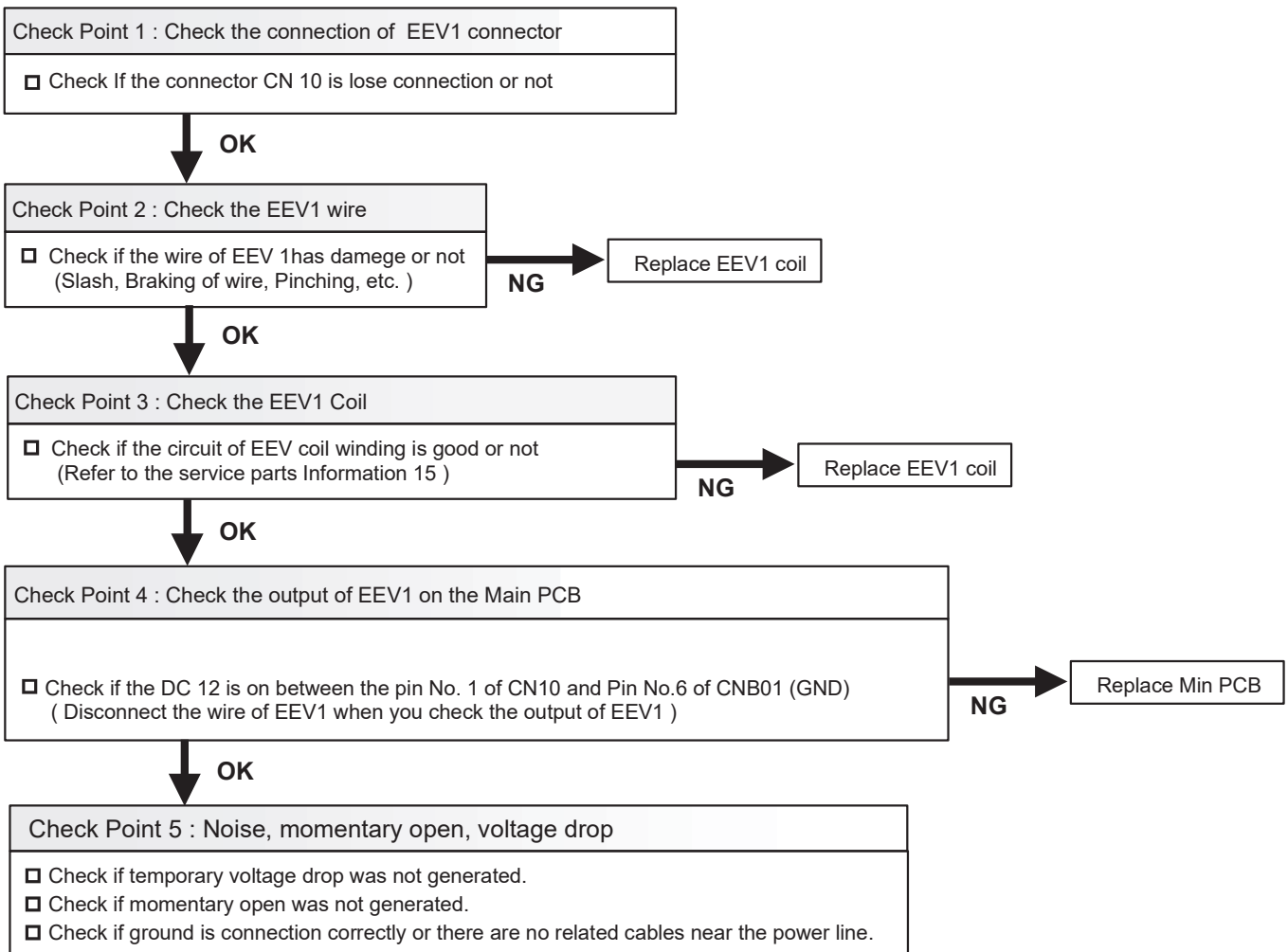

Trouble shooting 26 INDOOR UNIT Error Method: Indoor unit Drain pump Error	E53. 1	Indicate or Display: Outdoor Unit : E.5 U.1 Indoor Unit : Operation LED 5 times Flash, Timer LED 3 Times Flash, Filter LED Continuous Flash. Error Code : 5 3

Detective Actuators: Indoor Unit Controller PCB Circuit Float Switch	Detective details: When Float switch is ON for more than 3 minutes.
---	---

Forecast of Cause : 1. Drain Installation 2. Drain pipe line blockage 3. Float switch defective 4. Shorted connector/wire
5. Controller PCB defective / Drain pump defective

Check Point 1 : Check Drain pipe installation

Check Drain pipe installation (Refer to the installaion manual)
The Height limit for Drain pump, The angle of drain pipe, The angle of indoor unit



Check Point 2 : Check Drain pipe blockage

Check Drain pipe line blockage
The drain pump inlet and outlet, The connecting pipe, The drain pipe outlet



Check Point 3, 4 : Check Float Switch operation, connecting wire shorted.

Check operation of float switch.
Remove Float switch and check ON/OFF switching operation by using a meter.
>>If Float switch is defective, replace it.



Check Point 5 : Check controller PCB defective / Drain pump defective

Measure power supply (AC208- 230V) for the drain pump on the Power supply PCB (CN106) at the Float SW ON states.
>>If No voltage on the connector, replace the power supply PCB
>>If AC208- 230V on the connector, replace the Drain pump

Trouble shooting 27 E61. 5 OUTDOOR UNIT Error Method: Outdoor Unit Reverse Phase, Missing Phase Wire Error	Indicate or Display: Outdoor Unit : E. 6 1. 5 Indoor Unit : Operation LED 9 times Flash, Timer LED 15 Times Flash, Filter LED Continuous Flash. Error Code : 9 U / 6 1
--	---

Detective Actuators: Outdoor unit Main PCB	Detective details: <ul style="list-style-type: none"> • Reverse phase prevention circuit detected reversed phase input or input was not normal at the time of power ON. • Reverse phase prevention circuit detected open-phase after power ON.
--	--

Forecast of Cause :	1. Noise, momentary open, voltage drop 2. Power supply defective 3. Filter PCB (Main) defective 4. Main PCB defective
----------------------------	--

Check Point 1 : Noise, momentary open, voltage drop
<input type="checkbox"/> Check if temporary voltage drop was not generated. <input type="checkbox"/> Check if momentary open was not generated. <input type="checkbox"/> Check if ground is connection correctly or there are no related cables near the power line.



Check Point 2 : Check the power supply
<input type="checkbox"/> Power cable connection, open check



Check Point 3 : Check Filter PCB (Main) and Main PCB
<input type="checkbox"/> Check Filter PCB (Main) and Main PCB. (Refer to "Service Parts Information 3 ".)

Trouble shooting 28 E62. 3 OUTDOOR UNIT Error Method: Outdoor Unit EEPROM Access Error	Indicate or Display: Outdoor Unit : E. 6 2. 3 Indoor Unit : Operation LED 9 times Flash, Timer LED 15 Times Flash, Filter LED Continuous Flash. Error Code : 9 U / 6 2
--	---

Detective Actuators: Outdoor unit Main PCB	Detective details: •Access to EEPROM failed due to some cause after outdoor unit started.
--	---

Forecast of Cause : 1. Noise, momentary open, voltage drop 2. Main PCB defective

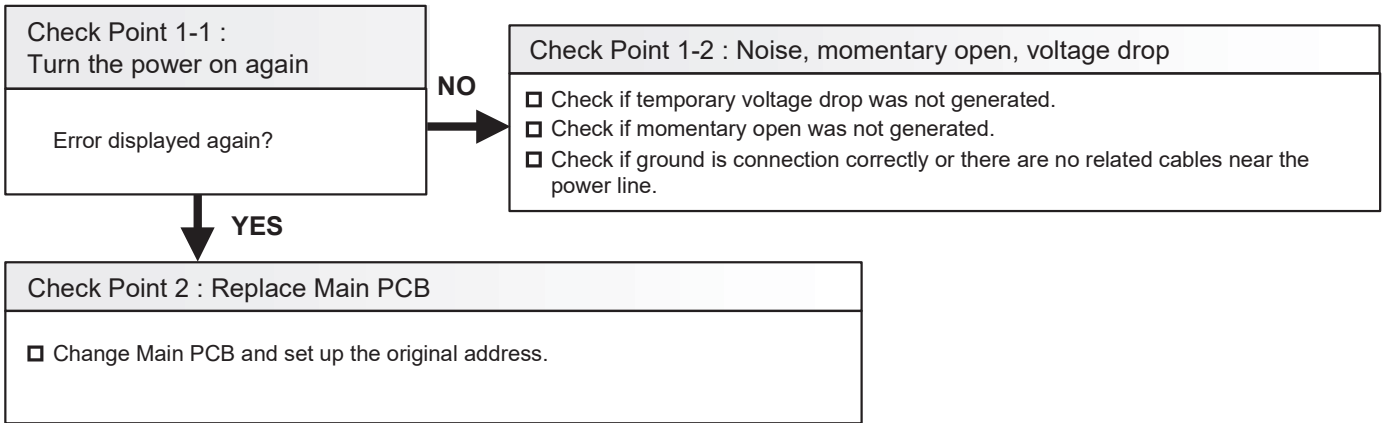

Trouble shooting 29 OUTDOOR UNIT Error Method: Inverters Communication Error	E62. 6	Indicate or Display: Outdoor Unit : E. 6 2. 6 Indoor Unit : Operation LED 9 times Flash, Timer LED 15 Times Flash, Filter LED Continuous Flash. Error Code : 9 U / 6 2
---	---------------	---

Detective Actuators: Outdoor unit Main PCB	Detective details: •Communication not received from Inverter PCB for 10 seconds or more
--	---

Forecast of Cause :	1. Noise 2. Main PCB to Inverter PCB wiring connection defective 3. Main PCB defective 4. Inverter PCB defective
----------------------------	---

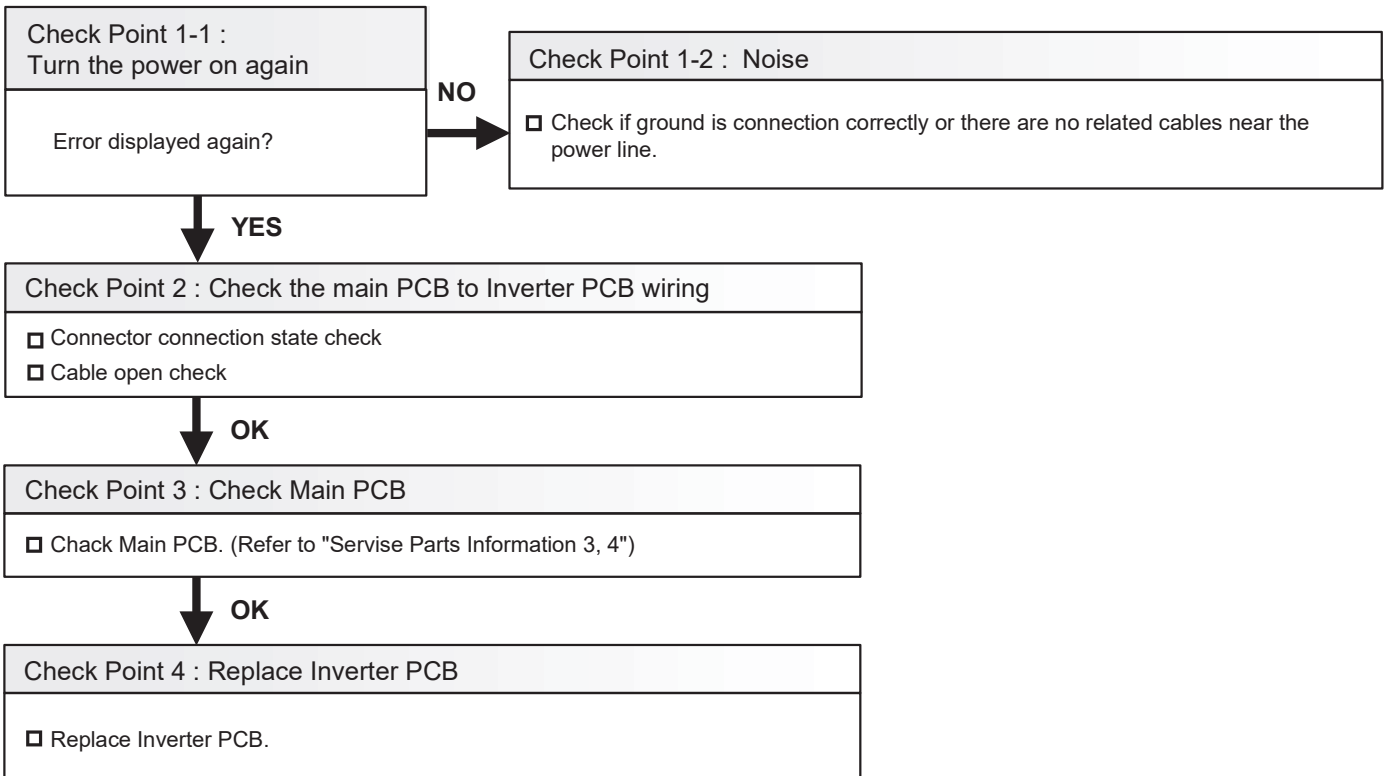

Caution
 By changing of DIP SW 4-2 to ON, the Back-up operation can start when the active outdoor unit exists on the multi outdoor unit connection. (Stand alone outdoor unit is impossible)
 The following conditions will be concerned in use of back-up operation. (Please do not use the system with back-up operation for long time.)
 - The operating compressor life time becomes shorter.
 - The operating performance may drop due to the limited active compressor(s).
 - The compressor may stop frequently by protection controlling.
 *In order to keep the operating capacity, the release of the Low noise mode setting might be necessary.

Trouble shooting 30 E62. 8 OUTDOOR UNIT Error Method: EEPROM data corrupted error	Indicate or Display: Outdoor Unit : E. 6 2. 8 Indoor Unit : Operation LED 9 times Flash, Timer LED 15 Times Flash, Filter LED Continuous Flash. Error Code : 9 U / 6 2
---	---

Detective Actuators: Outdoor unit Main PCB	Detective details: <ul style="list-style-type: none"> ▪ Set contents sum value memorized in EEPROM and sum value calculated based on the set contents read from EEPROM do not match * Regarding the sum value, only the contents set in the push button SW setting mode (F2) shall be the objective.
--	--

Forecast of Cause : 1. Noise, momentary open, voltage drop 2. Main PCB defective

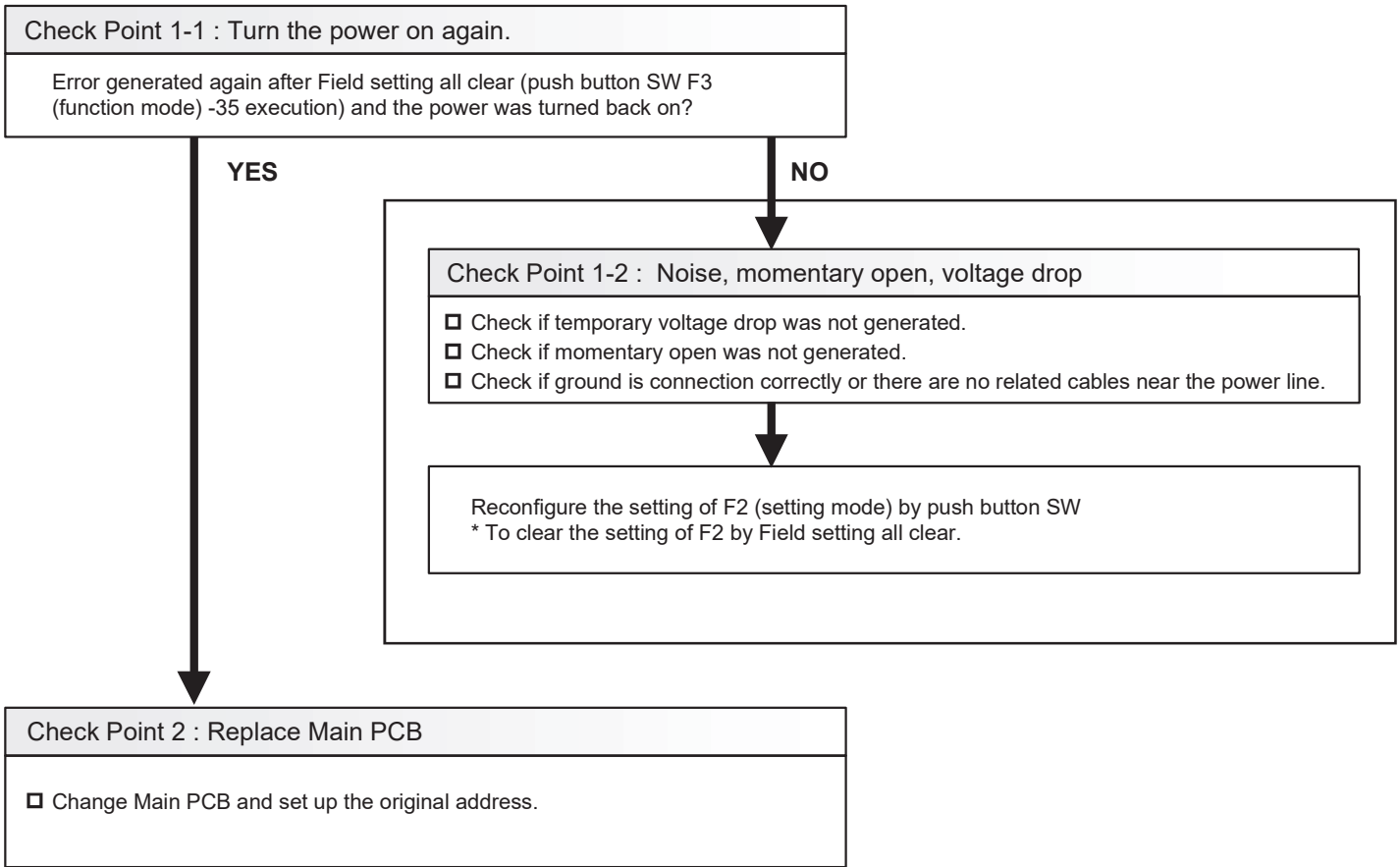

Trouble shooting 31 E63. 1 OUTDOOR UNIT Error Method: Inverter Error	Indicate or Display: Outdoor Unit : E. 6 3. 1 Indoor Unit : Operation LED 9 times Flash, Timer LED 15 Times Flash, Filter LED Continuous Flash. Error Code : 9 U / 6 3
--	---

Detective Actuators: Inverter PCB	Detective details: <ul style="list-style-type: none"> • Error information received from Inverter PCB. • When "Inverter PCB short interruption detection" or "Rush current limiting resistor temp. rise protection" occurs, Inverter error also occurs.
---	---

Forecast of Cause :	1. Noise, momentary open, voltage drop. 2. Power supply to Filter PCB (INV) to Inverter PCB wiring disconnection, open 3. Main PCB to Inverter PCB wiring disconnection, open 4. Magnetic Relay (for inverter) coil side wiring disconnection, open 5. Magnetic Relay activation circuit defective 6. Main PCB or Filter PCB (INV) or Inverter PCB defective 7. Cement Resistor Open circuit
----------------------------	--

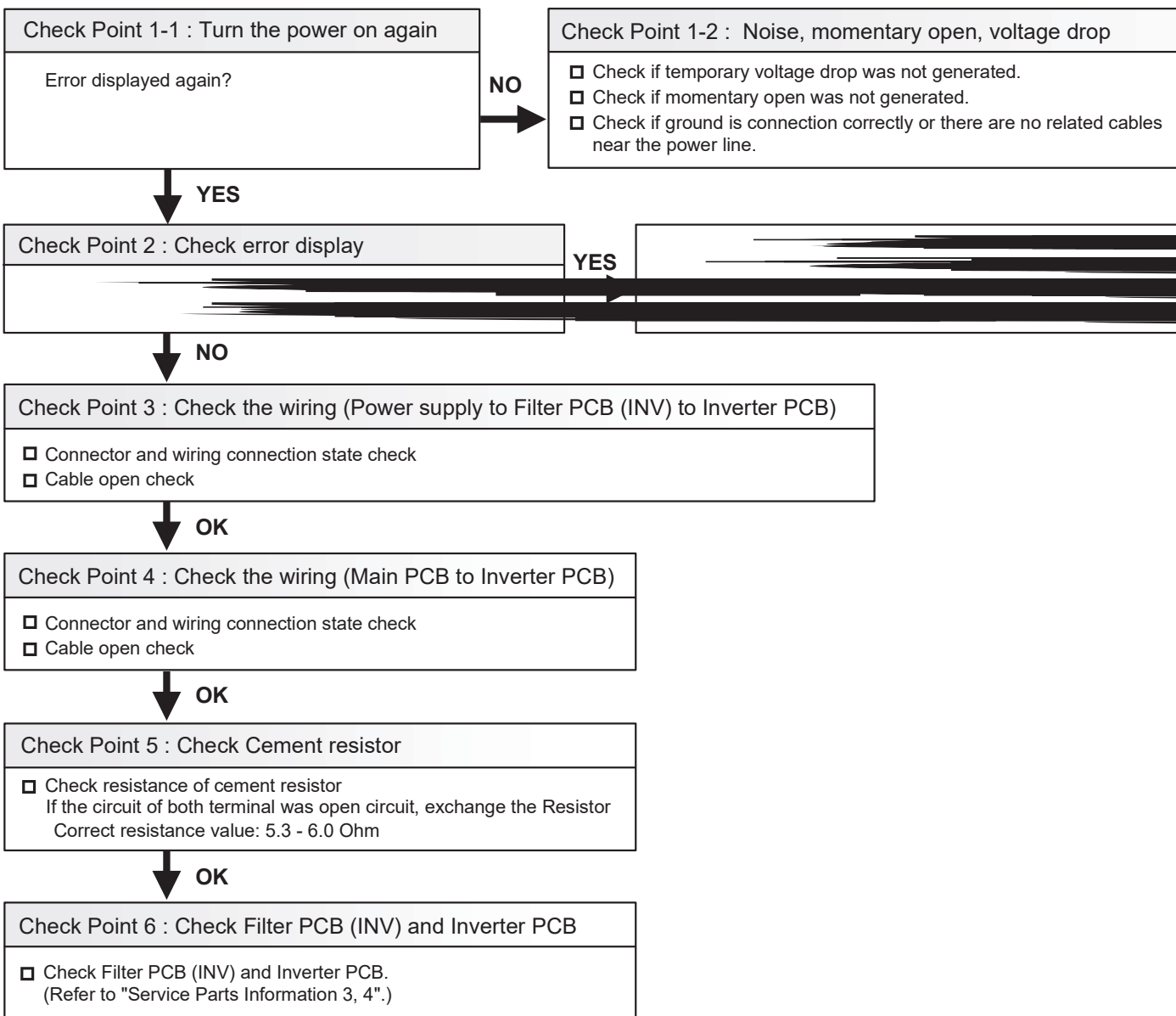

Caution
 By changing of DIP SW 4-2 to ON, the Back-up operation can start when the active outdoor unit exists on the multi outdoor unit connection. (Stand alone outdoor unit is impossible)
 The following conditions will be concerned in use of back-up operation. (Please do not use the system with back-up operation for long time.)
 - The operating compressor life time becomes shorter.
 - The operating performance may drop due to the limited active compressor(s).
 - The compressor may stop frequently by protection controlling.
 *In order to keep the operating capacity, the release of the Low noise mode setting might be necessary.

Trouble shooting 32 E67. 2 OUTDOOR UNIT Error Method: Inverter PCB short interruption Error	Indicate or Display: Outdoor Unit : E. 6 7. 2 Indoor Unit : No Display Error Code : No display
---	---

<u>Detective Actuators:</u> Inverter PCB	<u>Detective details:</u> • "Short interruption" received from Inverter PCB
--	---

<u>Forecast of Cause :</u>	1. Noise, momentary power failure, voltage drop 2. Magnetic Relay (for Inverter) coil side wiring disconnection, open 3. Power supply to Filter PCB (INV) to Inverter PCB wiring disconnection, open 4. Main PCB defective 5. Inverter PCB defective
-----------------------------------	---

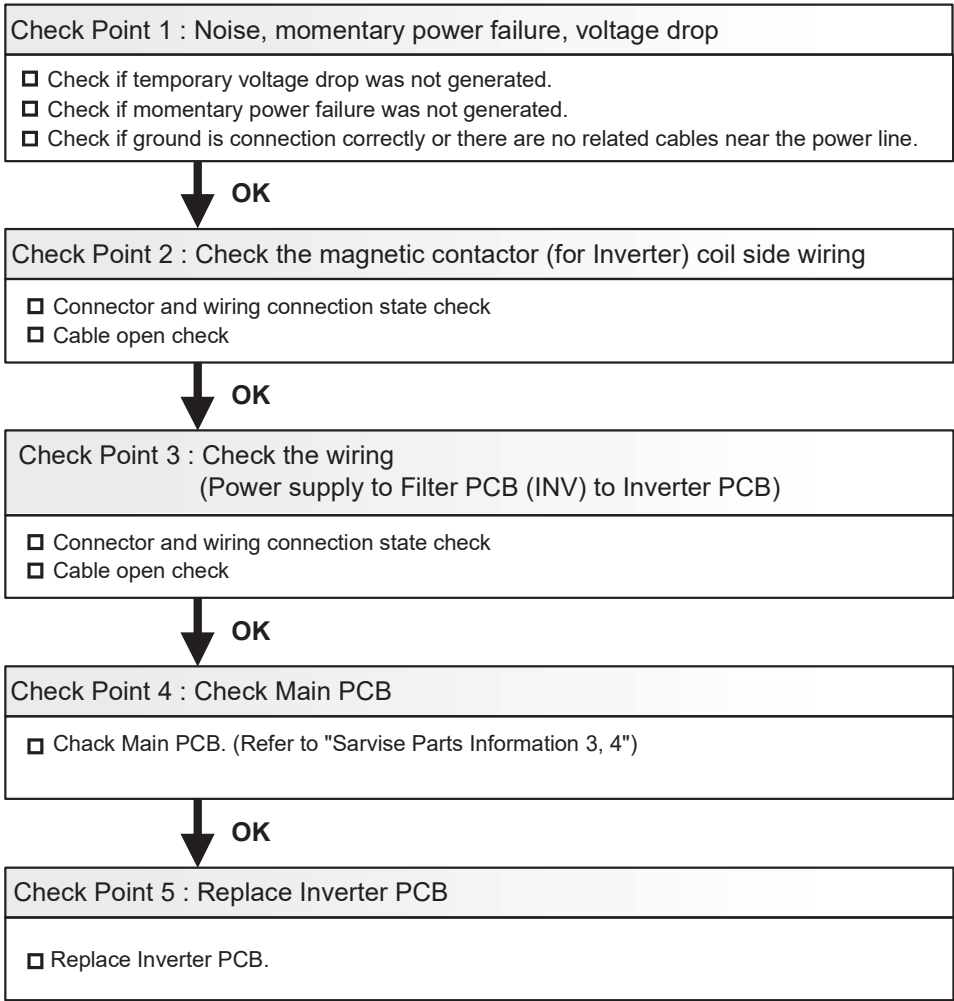

Trouble shooting 33 E68. 2 OUTDOOR UNIT Error Method: Rush Current Limiting Resistor Temp Rise Protection	Indicate or Display: Outdoor Unit : E. 6 8. 2 Indoor Unit : Operation LED 9 times Flash, Timer LED 15 Times Flash, Filter LED Continuous Flash. Error Code : 9 U / 6 8
---	---

Detective Actuators: Inverter PCB	Detective details: ▪ "Protection stop by "Rush current limiting resistor temperature rise detection" of inverter PCB" was generated 2 times.
---	--

Forecast of Cause :	1. Magnetic relay (for INV) coil side wiring disconnection, open 2. Power supply to Filter PCB (INV) to Inverter PCB wiring disconnection, open 3. Magnetic relay activation circuit defective 4. Main PCB to Inverter PCB wiring disconnection, open 5. Main PCB output AC208- 230V on CN130 defective Main PCB defective (output AC208- 230V on CN130 for Magnetic relay (INV) defective)
----------------------------	--

Check Point 1 : Check the magnetic relay (for invertert) coil side wiring
<input type="checkbox"/> Connector and wiring connection state check <input type="checkbox"/> Cable open check

↓ **OK**

Check Point 2 : Check Power supply to Filter PCB (INV) to inverter PCB wiring
<input type="checkbox"/> Connector and wiring connection state check <input type="checkbox"/> Cable open check

↓ **OK**

Check Point 3-1 : Magnetic relay activation circuit
<input type="checkbox"/> Check the DC Voltage (12V) of CN330 on INVERTER PCB

NG → **Replace Inverter PCB**

↓ **OK**

Check Point 4 : Check the wiring (Main PCB to Inverter PCB)
<input type="checkbox"/> Check the wiring connection. (CN138 on Main PCB to CN330 on Inverter PCB)

↓ **OK**

Check Point 5 : Main PCB output AC208- 230V for Magnetic relay
<input type="checkbox"/> Check the AC208- 230V of CN130 on Main PCB

↓ **OK**

Check Point 6 : Replace Main PCB
<input type="checkbox"/> Change Main PCB and set up the original address.

After fixing the problem and for canceling the Error, Error Reset (F3-40) will be required after power reset

Caution
By changing of DIP SW 4-2 to ON, the Back-up operation can start when the active outdoor unit exists on the multi outdoor unit connection. (Stand alone outdoor unit is impossible)
The following conditions will be concerned in use of back-up operation. (Please do not use the system with back-up operation for long time.)
- The operating compressor life time becomes shorter.
- The operating performance may drop due to the limited active compressor(s).
- The compressor may stop frequently by protection controlling.
*In order to keep the operating capacity, the release of the Low noise mode setting might be necessary.

Trouble shooting 34 E69. 1 OUTDOOR UNIT Error Method: Outdoor Unit Transmission PCB Parallel Communication Error	Indicate or Display: Outdoor Unit : E. 6 9. 1 Indoor Unit : Operation LED 9 times Flash, Timer LED 15 Times Flash, Filter LED Continuous Flash. / Operation LED 1 time Flash, Timer LED 4 Times Flash, Filter LED Continuous Flash. Error Code : 9 U / 6 9 / 1 4 / 14.1 / 14.3*
--	--

*When this error occurs on the Slave outdoor unit, Error code 69.1 is transferred to each device on the network.
When this error occurs on the Master outdoor unit, the indoor unit on the network indicates 14 (14.3 No communication from Outdoor unit), and Service tool indicates 14.1 (Outdoor unit Network communication Error).

Detective Actuators: Outdoor unit Main PCB	Detective details: •When Parallel communication error (Communication reset occurs continuously more than specified times) is detected.
--	--

Forecast of Cause :	1. Noise 2. Communication PCB connection defective 3. Communication PCB defective 4. Main PCB defective
----------------------------	--

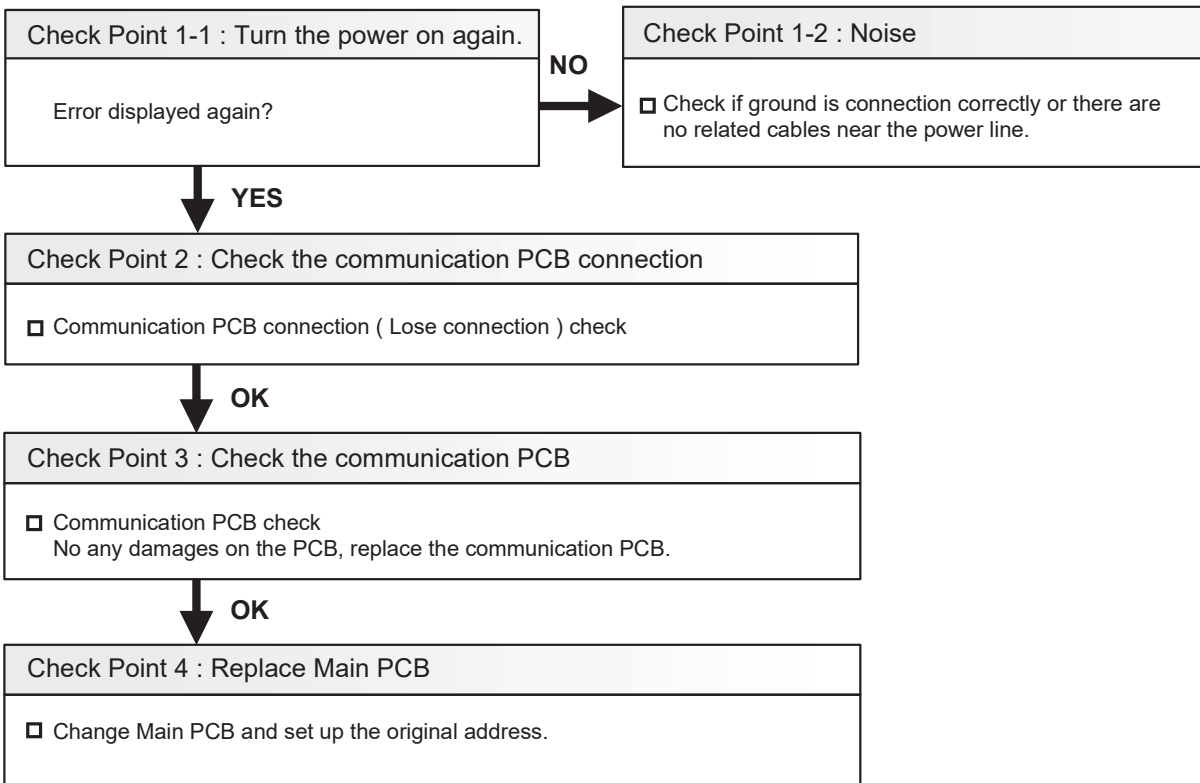

Trouble shooting 35 E71. 1 OUTDOOR UNIT Error Method: Discharge Temp. Sensor 1 Error	Indicate or Display: Outdoor Unit : E. 7 1. 1 Indoor Unit : Operation LED 9 times Flash, Timer LED 15 Times Flash, Filter LED Continuous Flash. Error Code : 9 U / 7 1
--	---

Detective Actuators: Discharge temp. sensor 1	Detective details: <ul style="list-style-type: none"> • Discharge temp. sensor 1 short detected • Discharge temp. sensor 1 open detected after compressor 1 operated continuously for 5 minutes or more
---	---

Forecast of Cause :

1. Connector connection defective, open
2. Sensor defective
3. Main PCB defective

Check Point 1 : Check the connector connection and cable open

Connector connection state check
 Cable open check



Check Point 2 : Check the sensor

Sensor characteristics check (Disconnect the sensor from the PCB and check.)
 * For the sensor characteristics, refer to the "Service Parts Information 25".



Check Point 3 : Check voltage of Main PCB (DC5.0V)

DC

Main PCB (CN162: 1-2) voltage value = 5V
Remove the sensor from Main PCB, check the voltage.

	1	1	BLACK		
	2	2	BLACK		THERMISTOR (DIS.TEMP.1)
	3	3	BLACK		
	4	4	BLACK		
CN162	5	5			THERMISTOR (COMP SHELL 1)
	6	6			
	7	7			
	8	8			

Discharge temp. sensor 1 (CN162: 1-2)

► If the voltage does not appear, replace Main PCB and set up original address.

Caution

By changing of DIP SW 4-2 to ON, the Back-up operation can start when the active outdoor unit exists on the multi outdoor unit connection. (Stand alone outdoor unit is impossible)

The following conditions will be concerned in use of back-up operation. (Please do not use the system with back-up operation for long time.)

- The operating compressor life time becomes shorter.
- The operating performance may drop due to the limited active compressor(s).
- The compressor may stop frequently by protection controlling.

*In order to keep the operating capacity, the release of the Low noise mode setting might be necessary.

Trouble shooting 36 E72. 1 OUTDOOR UNIT Error Method: Compressor Temp Sensor 1 Error	Indicate or Display: Outdoor Unit : E. 7 2. 1 Indoor Unit : Operation LED 9 times Flash, Timer LED 15 Times Flash, Filter LED Continuous Flash. Error Code : 9 U / 7 2
--	---

Detective Actuators: Compressor temp. sensor 1	Detective details: <ul style="list-style-type: none"> • Compressor temp. sensor 1 short detected • Compressor temp. sensor 1 open detected after compressor 1 operated continuously for 5 minutes or more
--	--

Forecast of Cause : <ol style="list-style-type: none"> 1. Connector connection defective, open 2. Sensor defective 3. Main PCB defective
--

Check Point 1 : Check the connector connection and cable open
<input type="checkbox"/> Connector connection state check <input type="checkbox"/> Cable open check



Check Point 2 : Check the sensor
<input type="checkbox"/> Thermistor characteristics check (Disconnect the sensor from the PCB and check.) * For the sensor characteristics, refer to the "Service Parts Information 25".



Check Point 3 : Check voltage of Main PCB (DC5.0V)	<div style="border: 1px solid black; padding: 5px; display: inline-block;"> DC </div>																											
<input type="checkbox"/> Main PCB (CN162: 3-4) voltage value = 5V <u>Remove the sensor from Main PCB, check the voltage.</u>																												
<table border="1" style="margin: auto;"> <tr> <td colspan="2"></td> <td style="text-align: center;">THERMISTOR (DIS.TEMP.1)</td> </tr> <tr> <td style="text-align: center;">1</td> <td style="text-align: center;">1</td> <td style="text-align: center;">BLACK </td> </tr> <tr> <td style="text-align: center;">2</td> <td style="text-align: center;">2</td> <td style="text-align: center;">BLACK </td> </tr> <tr> <td style="text-align: center;">3</td> <td style="text-align: center;">3</td> <td style="text-align: center;">BLACK </td> </tr> <tr> <td style="text-align: center;">4</td> <td style="text-align: center;">4</td> <td style="text-align: center;">BLACK </td> </tr> <tr> <td style="text-align: center;">5</td> <td style="text-align: center;">5</td> <td style="text-align: center;">THERMISTOR (COMP SHELL 1)</td> </tr> <tr> <td style="text-align: center;">6</td> <td style="text-align: center;">6</td> <td></td> </tr> <tr> <td style="text-align: center;">7</td> <td style="text-align: center;">7</td> <td></td> </tr> <tr> <td style="text-align: center;">8</td> <td style="text-align: center;">8</td> <td></td> </tr> </table>				THERMISTOR (DIS.TEMP.1)	1	1	BLACK	2	2	BLACK	3	3	BLACK	4	4	BLACK	5	5	THERMISTOR (COMP SHELL 1)	6	6		7	7		8	8	
		THERMISTOR (DIS.TEMP.1)																										
1	1	BLACK																										
2	2	BLACK																										
3	3	BLACK																										
4	4	BLACK																										
5	5	THERMISTOR (COMP SHELL 1)																										
6	6																											
7	7																											
8	8																											
Compressor temp. sensor 1 (CN162: 3-4)																												
▶ <u>If the voltage does not appear, replace Main PCB and set up original address.</u>																												

Caution
By changing of DIP SW 4-2 to ON, the Back-up operation can start when the active outdoor unit exists on the multi outdoor unit connection. (Stand alone outdoor unit is impossible)
The following conditions will be concerned in use of back-up operation. (Please do not use the system with back-up operation for long time.)

- The operating compressor life time becomes shorter.
- The operating performance may drop due to the limited active compressor(s).
- The compressor may stop frequently by protection controlling.

*In order to keep the operating capacity, the release of the Low noise mode setting might be necessary.

Trouble shooting 37 E73.4 OUTDOOR UNIT Error Method: Heat Ex.1 Gas Temp Sensor Error	Indicate or Display: Outdoor Unit : E. 7 3. 4 Indoor Unit : Operation LED 9 times Flash, Timer LED 15 Times Flash, Filter LED Continuous Flash. Error Code : 9 U / 7 3
---	---

Detective Actuators: Heat ex.1 gas temp. sensor	Detective details: • Heat ex.1 gas temp. sensor short or open detected
---	--

Forecast of Cause :

1. Connector connection defective, open
2. Sensor defective
3. Main PCB defective

Check Point 1 : Check the connector connection and cable open

Connector connection state check
 Cable open check



Check Point 2: Check the sensor

Sensor characteristics check (Disconnect the sensor from the PCB and check.)
 * For the sensor characteristics, refer to the "Service Parts Information 25".



Check Point 3 : Check voltage of Main PCB (DC5.0V)



Main PCB (CN163: 3-4) voltage value = 5V
Remove the sensor from Main PCB, check the voltage.

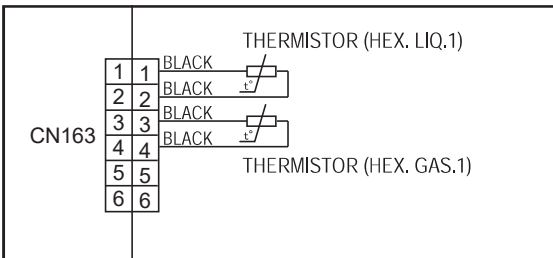

Heat ex.1 gas temp. sensor (CN163: 3-4)

► **If the voltage does not appear, replace Main PCB and set up original address.**

Caution
 By changing of DIP SW 4-2 to ON, the Back-up operation can start when the active outdoor unit exists on the multi outdoor unit connection. (Stand alone outdoor unit is impossible)
 The following conditions will be concerned in use of back-up operation. (Please do not use the system with back-up operation for long time.)
 - The operating compressor life time becomes shorter.
 - The operating performance may drop due to the limited active compressor(s).
 - The compressor may stop frequently by protection controlling.
 *In order to keep the operating capacity, the release of the Low noise mode setting might be necessary.

Trouble shooting 38 E 73. 5
OUTDOOR UNIT Error Method:
Heat Ex.1 Liquid Temp
Sensor Error

Indicate or Display:
Outdoor Unit : E. 7 3. 5
Indoor Unit : Operation LED 9 times Flash, Timer LED 15 Times Flash,
Filter LED Continuous Flash.
Error Code : 9 U / 7 3

Detective Actuators:

Heat ex.1 liquid temp. sensor

Detective details:

- Heat ex.1 liquid temp. sensor short or open detected

- Forecast of Cause :**
1. Connector connection defective, open
 2. Sensor defective
 3. Main PCB defective

Check Point 1 : Check the connector connection and cable open

- Connector connection state check
- Cable open check



Check Point 2: Check the sensor

- Sensor characteristics check (Disconnect the sensor from the PCB and check.)
 * For the sensor characteristics, refer to the "Service Parts Information 25".



Check Point 3 : Check voltage of Main PCB (DC5.0V)

- Main PCB (CN163: 1-2) voltage value = 5V
Remove the sensor from Main PCB, check the voltage.

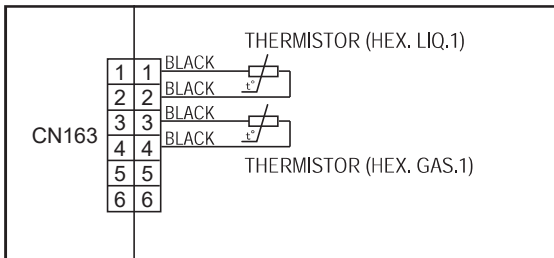

Heat ex.1 liquid temp. sensor (CN163: 1-2)

► **If the voltage does not appear, replace Main PCB and set up original address.**

Trouble shooting 39 E73. 6 OUTDOOR UNIT Error Method: Heat Ex.2 Gas Temp Sensor Error	Indicate or Display: Outdoor Unit : E. 7 3. 6 Indoor Unit : Operation LED 9 times Flash, Timer LED 15 Times Flash, Filter LED Continuous Flash. Error Code : 9 U / 7 3
--	---

Detective Actuators: Heat ex.2 gas temp. sensor	Detective details: • Heat ex.2 gas temp. sensor short or open detected
---	--

Forecast of Cause :

1. Connector connection defective, open
2. Sensor defective
3. Main PCB defective

Check Point 1 : Check the connector connection and cable open

Connector connection state check
 Cable open check



Check Point 2: Check the sensor

Sensor characteristics check (Disconnect the sensor from the PCB and check.)
* For the sensor characteristics, refer to the "Service Parts Information 25".



Check Point 3 : Check voltage of Main PCB (DC5.0V)



Main PCB (CN164: 3-4) voltage value = 5V
Remove the sensor from Main PCB, check the voltage.

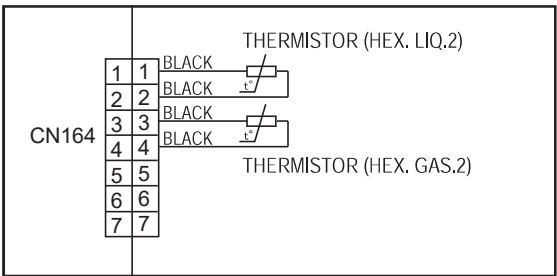

Heat ex.2 gas temp. sensor (CN164: 3-4)

► If the voltage does not appear, replace Main PCB and set up original address.

Caution

By changing of DIP SW 4-2 to ON, the Back-up operation can start when the active outdoor unit exists on the multi outdoor unit connection. (Stand alone outdoor unit is impossible)

The following conditions will be concerned in use of back-up operation. (Please do not use the system with back-up operation for long time.)

- The operating compressor life time becomes shorter.
- The operating performance may drop due to the limited active compressor(s).
- The compressor may stop frequently by protection controlling.

*In order to keep the operating capacity, the release of the Low noise mode setting might be necessary.

Trouble shooting 40 E73. 7 OUTDOOR UNIT Error Method: Heat Ex.2 Liquid Temp Sensor Error	Indicate or Display: Outdoor Unit : E. 7 3. 7 Indoor Unit : Operation LED 9 times Flash, Timer LED 15 Times Flash, Filter LED Continuous Flash. Error Code : 9 U / 7 3
---	---

Detective Actuators: Heat ex.2 liquid temp. sensor	Detective details: • Heat ex.2 liquid temp. sensor short or open detected
--	---

Forecast of Cause : <ol style="list-style-type: none"> 1. Connector connection defective, open 2. Sensor defective 3. Main PCB defective
--

Check Point 1 : Check the connector connection and cable open
<input type="checkbox"/> Connector connection state check <input type="checkbox"/> Cable open check



Check Point 2: Check the sensor
<input type="checkbox"/> Sensor characteristics check (Disconnect the sensor from the PCB and check.) * For the sensor characteristics, refer to the "Service Parts Information 25".



Check Point 3 : Check voltage of Main PCB (DC5.0V)	<div style="border: 1px solid black; padding: 2px; display: inline-block;">DC</div> 																								
<input type="checkbox"/> Main PCB (CN164: 1-2) voltage value = 5V <u>Remove the sensor from Main PCB, check the voltage.</u>																									
<table border="1" style="width: 100%; border-collapse: collapse;"> <tr> <td rowspan="7" style="text-align: center; vertical-align: middle;">CN164</td> <td style="text-align: center;">1</td> <td style="text-align: center;">1</td> <td>BLACK</td> <td rowspan="4" style="text-align: center; vertical-align: middle;">THERMISTOR (HEX. LIQ.2)</td> </tr> <tr> <td style="text-align: center;">2</td> <td style="text-align: center;">2</td> <td>BLACK</td> </tr> <tr> <td style="text-align: center;">3</td> <td style="text-align: center;">3</td> <td>BLACK</td> </tr> <tr> <td style="text-align: center;">4</td> <td style="text-align: center;">4</td> <td>BLACK</td> </tr> <tr> <td style="text-align: center;">5</td> <td style="text-align: center;">5</td> <td></td> <td rowspan="3" style="text-align: center; vertical-align: middle;">THERMISTOR (HEX. GAS.2)</td> </tr> <tr> <td style="text-align: center;">6</td> <td style="text-align: center;">6</td> <td></td> </tr> <tr> <td style="text-align: center;">7</td> <td style="text-align: center;">7</td> <td></td> </tr> </table>	CN164	1	1	BLACK	THERMISTOR (HEX. LIQ.2)	2	2	BLACK	3	3	BLACK	4	4	BLACK	5	5		THERMISTOR (HEX. GAS.2)	6	6		7	7		
CN164		1	1	BLACK		THERMISTOR (HEX. LIQ.2)																			
		2	2	BLACK																					
		3	3	BLACK																					
		4	4	BLACK																					
		5	5		THERMISTOR (HEX. GAS.2)																				
		6	6																						
	7	7																							
Heat ex.2 liquid temp. sensor (CN164: 1-2)																									
► <u>If the voltage does not appear, replace Main PCB and set up original address.</u>																									

Trouble shooting 41 E74. 1 OUTDOOR UNIT Error Method: Outdoor Temp Sensor Error	Indicate or Display: Outdoor Unit : E. 7 4. 1 Indoor Unit : Operation LED 9 times Flash, Timer LED 15 Times Flash, Filter LED Continuous Flash. Error Code : 9 U / 7 4
--	---

Detective Actuators: Outdoor temp. sensor	Detective details: • Outdoor temp. sensor short or open detected
---	--

Forecast of Cause : <ol style="list-style-type: none"> 1. Connector connection defective, open 2. Sensor defective 3. Main PCB defective
--

Check Point 1 : Check the connector connection and cable open
<input type="checkbox"/> Connector connection state check <input type="checkbox"/> Cable open check



Check Point 2: Check the sensor
<input type="checkbox"/> Sensor characteristics check (Disconnect the sensor from the PCB and check.) * For the sensor characteristics, refer to the "Service Parts Information 25".



Check Point 3 : Check voltage of Main PCB (DC5.0V)	<div style="border: 1px solid black; padding: 2px; display: inline-block;">DC</div> 												
<input type="checkbox"/> Main PCB (CN144:1-3) voltage value = 5V <u>Remove the sensor from Main PCB, check the voltage.</u>													
<div style="border: 1px solid black; padding: 5px; width: fit-content;"> <table style="border-collapse: collapse;"> <tr> <td style="padding-right: 10px;">CN144</td> <td style="border: 1px solid black; padding: 2px;">1</td> <td style="border: 1px solid black; padding: 2px;">1</td> <td style="padding-left: 5px;">BLACK</td> </tr> <tr> <td></td> <td style="border: 1px solid black; padding: 2px;">2</td> <td style="border: 1px solid black; padding: 2px;">2</td> <td style="padding-left: 5px;">BLACK</td> </tr> <tr> <td></td> <td style="border: 1px solid black; padding: 2px;">3</td> <td style="border: 1px solid black; padding: 2px;">3</td> <td style="padding-left: 5px;">BLACK</td> </tr> </table> <div style="margin-left: 20px; margin-top: 5px;"> </div> </div>	CN144	1	1	BLACK		2	2	BLACK		3	3	BLACK	
CN144	1	1	BLACK										
	2	2	BLACK										
	3	3	BLACK										
Outdoor temp. sensor (CN144:1-3)													
► If the voltage does not appear, replace Main PCB and set up original address.													

Caution By changing of DIP SW 4-2 to ON, the Back-up operation can start when the active outdoor unit exists on the multi outdoor unit connection. (Stand alone outdoor unit is impossible) The following conditions will be concerned in use of back-up operation. (Please do not use the system with back-up operation for long time.) <ul style="list-style-type: none"> - The operating compressor life time becomes shorter. - The operating performance may drop due to the limited active compressor(s). - The compressor may stop frequently by protection controlling. *In order to keep the operating capacity, the release of the Low noise mode setting might be necessary.

Trouble shooting 42 E75. 1 OUTDOOR UNIT Error Method: Suction Gas Temp Sensor Error	Indicate or Display: Outdoor Unit : E. 7 5. 1 Indoor Unit : Operation LED 9 times Flash, Timer LED 15 Times Flash, Filter LED Continuous Flash. Error Code : 9 U / 7 5
---	---

Detective Actuators: Suction gas temp. sensor	Detective details: • Suction gas temp. sensor short or open detected
---	--

Forecast of Cause : <ol style="list-style-type: none"> 1. Connector connection defective, open 2. Sensor defective 3. Main PCB defective
--

Check Point 1 : Check the connector connection and cable open
<input type="checkbox"/> Connector connection state check <input type="checkbox"/> Cable open check



Check Point 2 : Check the sensor
<input type="checkbox"/> Sensor characteristics check (Disconnect the sensor from the PCB and check.) * For the sensor characteristics, refer to the "Service Parts Information 25".

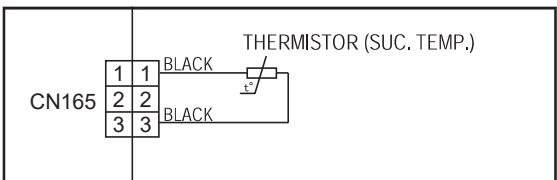

Check Point 3 : Check voltage of Main PCB (DC5.0V)	<div style="border: 1px solid black; padding: 5px; display: inline-block;"> DC  </div>
<input type="checkbox"/> Main PCB (CN165:1-3) voltage value = 5V <u>Remove the sensor from Main PCB, check the voltage.</u>	
	
Suction gas temp. sensor (CN165:1-3)	
▶ <u>If the voltage does not appear, replace Main PCB and set up original address.</u>	

Trouble shooting 43 E77. 1 OUTDOOR UNIT Error Method: Heat Sink Temp Sensor Error	Indicate or Display: Outdoor Unit : E. 7 7. 1 Indoor Unit : Operation LED 9 times Flash, Timer LED 15 Times Flash, Filter LED Continuous Flash. Error Code : 9 U / 7 7
---	---

Detective Actuators: Heat sink temp. sensor	Detective details: • Heat sink temp. sensor open/short detected
---	---

Forecast of Cause : <ol style="list-style-type: none"> 1. Connector connection defective, open 2. Sensor defective 3. Inverter PCB defective
--

Check Point 1 : Check the connector connection and cable open
<input type="checkbox"/> Connector connection state check <input type="checkbox"/> Cable open check



Check Point 2 : Check the sensor
<input type="checkbox"/> Sensor characteristics check (Disconnect the sensor from the PCB and check.) * For the sensor characteristics, refer to the "Service Parts Information 25".

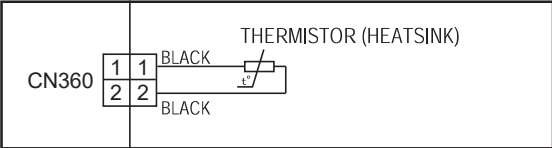

Check Point 3 : Check voltage of Inverter PCB (DC5.0V)	<div style="border: 1px solid black; padding: 5px; display: inline-block;"> DC  </div>
<input type="checkbox"/> Inverter PCB (CN360: 1-2) voltage value = 5V <u>Remove the sensor from Inverter PCB, check the voltage.</u>	
	
Heat sink temp. sensor (CN360: 1-2) ▶ If the voltage does not appear, replace Inverter PCB.	

Caution
By changing of DIP SW 4-2 to ON, the Back-up operation can start when the active outdoor unit exists on the multi outdoor unit connection. (Stand alone outdoor unit is impossible)
The following conditions will be concerned in use of back-up operation. (Please do not use the system with back-up operation for long time.)

- The operating compressor life time becomes shorter.
- The operating performance may drop due to the limited active compressor(s).
- The compressor may stop frequently by protection controlling.

*In order to keep the operating capacity, the release of the Low noise mode setting might be necessary.

Trouble shooting 44 OUTDOOR UNIT Error Method: Sub-cool Heat EX. Gas outlet Temp Sensor Error	E82. 2	Indicate or Display: Outdoor Unit : E. 8 2. 2 Indoor Unit : Operation LED 9 times Flash, Timer LED 15 Times Flash, Filter LED Continuous Flash.
		Error Code : 9 U / 8 2

Detective Actuators: Sub-cooling heat ex. gas outlet temp. sensor	Detective details: • Sub-cooling heat ex. gas outlet temp. sensor short or open detected.
---	---

Forecast of Cause :	1. Connector connection defective, open 2. Sensor defective 3. Main PCB defective
----------------------------	---

Check Point 1 : Check the connector connection and cable open
<input type="checkbox"/> Connector connection state check <input type="checkbox"/> Cable open check



Check Point 2 : Check the sensor
<input type="checkbox"/> Sensor characteristics check (Disconnect the sensor from the PCB and check.) * For the sensor characteristics, refer to the "Service Parts Information 25".



Check Point 3 : Check voltage of Main PCB (DC5.0V)



<input type="checkbox"/> Main PCB (CN142: 7-8) voltage value = 5V <u>Remove the sensor from Main PCB, check the voltage.</u>

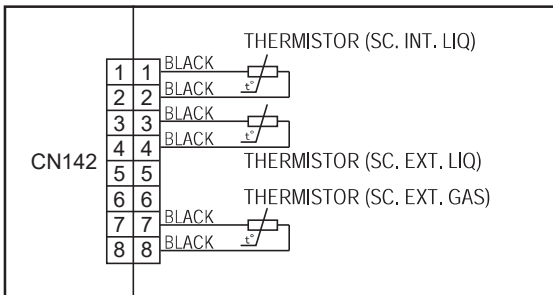

Sub-cooling heat ex. gas outlet temp. sensor (CN142: 7-8)

► **If the voltage does not appear, replace Main PCB and set up original address.**

Trouble shooting 45 E83. 1 OUTDOOR UNIT Error Method: Liquid Pipe Temp. Sensor 1 Error	Indicate or Display: Outdoor Unit : E. 8 3. 1 Indoor Unit : Operation LED 9 times Flash, Timer LED 15 Times Flash, Filter LED Continuous Flash. Error Code : 9 U / 8 3

Detective Actuators: Liquid pipe temp. sensor 1	Detective details: • Liquid pipe temp. sensor 1 short or open detected
---	--

Forecast of Cause :	1. Connector connection defective, open 2. Sensor defective 3. Main PCB defective
----------------------------	---

Check Point 1 : Check the connector connection and cable open
<input type="checkbox"/> Connector connection state check <input type="checkbox"/> Cable open check



Check Point 2 : Check the sensor
<input type="checkbox"/> Sensor characteristics check (Disconnect the sensor from the PCB and check.) * For the sensor characteristics, refer to the "Service Parts Information 25".



Check Point 3 : Check voltage of Main PCB (DC5.0V)	<div style="border: 1px solid black; padding: 5px; display: inline-block;"> DC </div>																				
<input type="checkbox"/> Main PCB (CN142: 1-2) voltage value = 5V <u>Remove the sensor from Main PCB, check the voltage.</u>																					
<table border="1" style="width: 100%; border-collapse: collapse;"> <tr> <td colspan="2"></td> <td style="text-align: center;">THERMISTOR (SC. INT. LIQ)</td> </tr> <tr> <td rowspan="8" style="text-align: center; vertical-align: middle;">CN142</td> <td style="text-align: center;">1</td> <td>BLACK </td> </tr> <tr> <td style="text-align: center;">2</td> <td>BLACK </td> </tr> <tr> <td style="text-align: center;">3</td> <td>BLACK </td> </tr> <tr> <td style="text-align: center;">4</td> <td>BLACK </td> </tr> <tr> <td style="text-align: center;">5</td> <td>THERMISTOR (SC. EXT. LIQ)</td> </tr> <tr> <td style="text-align: center;">6</td> <td>THERMISTOR (SC. EXT. GAS)</td> </tr> <tr> <td style="text-align: center;">7</td> <td>BLACK </td> </tr> <tr> <td style="text-align: center;">8</td> <td>BLACK </td> </tr> </table>			THERMISTOR (SC. INT. LIQ)	CN142	1	BLACK	2	BLACK	3	BLACK	4	BLACK	5	THERMISTOR (SC. EXT. LIQ)	6	THERMISTOR (SC. EXT. GAS)	7	BLACK	8	BLACK	
		THERMISTOR (SC. INT. LIQ)																			
CN142	1	BLACK																			
	2	BLACK																			
	3	BLACK																			
	4	BLACK																			
	5	THERMISTOR (SC. EXT. LIQ)																			
	6	THERMISTOR (SC. EXT. GAS)																			
	7	BLACK																			
	8	BLACK																			
Liquid pipe temp. sensor 1 (CN142: 1-2) ▶ <u>If the voltage does not appear, replace Main PCB and set up original address.</u>																					

Trouble shooting 46 E83. 2 OUTDOOR UNIT Error Method: Liquid Pipe Temp. Sensor 2 Error	Indicate or Display: Outdoor Unit : E. 8 3. 2 Indoor Unit : Operation LED 9 times Flash, Timer LED 15 Times Flash, Filter LED Continuous Flash. Error Code : 9 U / 8 3
--	---

Detective Actuators: Liquid pipe temp. sensor 2	Detective details: • Liquid pipe temp. sensor 2 short or open detected
---	--

Forecast of Cause :

1. Connector connection defective, open
2. Sensor defective
3. Main PCB defective

Check Point 1 : Check the connector connection and cable open

- Connector connection state check
- Cable open check



Check Point 2 : Check the sensor

- Sensor characteristics check (Disconnect the sensor from the PCB and check.)
* For the sensor characteristics, refer to the "Service Parts Information 25".



Check Point 3 : Check voltage of Main PCB (DC5.0V)

DC

- Main PCB (CN142: 3-4) voltage value = 5V
Remove the sensor from Main PCB, check the voltage.

		THERMISTOR (SC. INT. LIQ)		
CN142	1	1	BLACK	
	2	2	BLACK	
	3	3	BLACK	
	4	4	BLACK	
			THERMISTOR (SC. EXT. LIQ)	
	5	5		
	6	6		
			THERMISTOR (SC. EXT. GAS)	
7	7	BLACK		
8	8	BLACK		

Liquid pipe temp. sensor 2 (CN142: 3-4)

► **If the voltage does not appear, replace Main PCB and set up original address.**

Trouble shooting 47 E84. 1 OUTDOOR UNIT Error Method: Current Sensor 1 abnormal	Indicate or Display: Outdoor Unit : E. 8 4. 1 Indoor Unit : Operation LED 9 times Flash, Timer LED 15 Times Flash, Filter LED Continuous Flash. Error Code : 9 U / 8 4
---	---

Detective Actuators: Judgment from value sensed by current sensor 1 (current sensor for inverter) * Current sensor 1 is mounted on Filter PCB(INV)	Detective details: <ul style="list-style-type: none"> • "Protection stop by "inverter speed ≥ 20rps and sensor value 0A continued for 1 min"" was generated 2 times • Sensor value while inverter stopped = maximum was detected
---	---

Forecast of Cause : <ol style="list-style-type: none"> 1. Power supply defective 2. Power cable disconnection , open 3. Filter PCB (INV) to Inverter PCB CT system wiring connector disconnection, open 4. Power supply to Filter PCB (INV) to Inverter PCB wiring disconnection, open 5. Filter PCB(INV) defective (Power supply section, current sensor section) 6. Inverter PCB defective

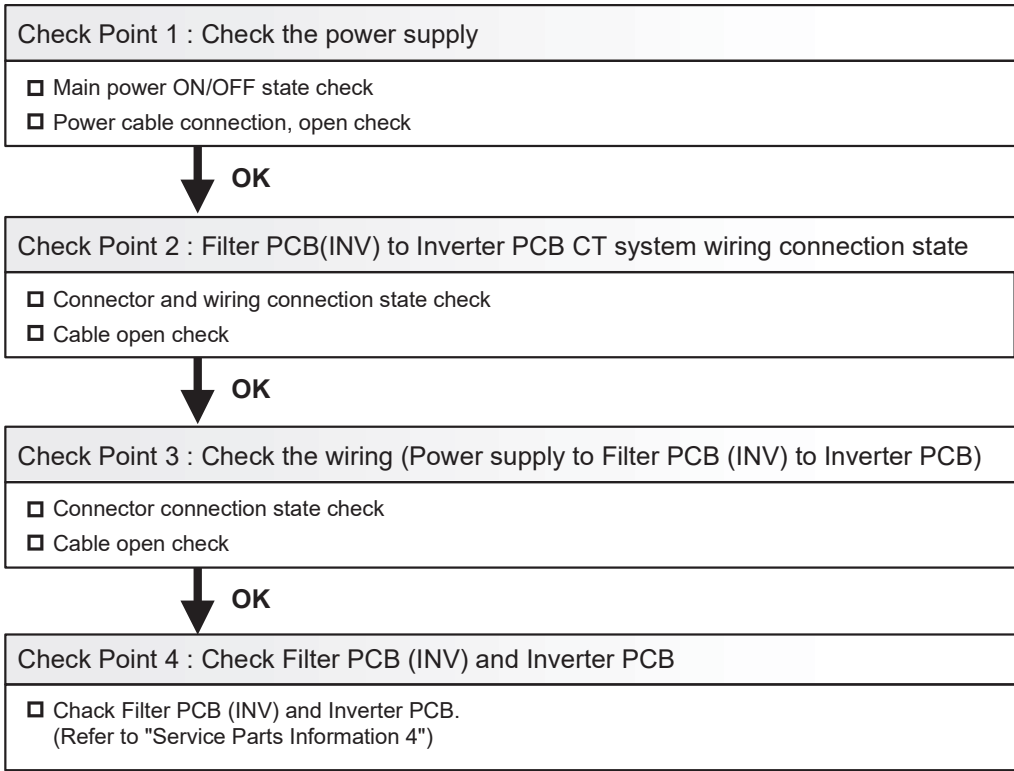

After fixing the problem and for canceling the Error, Error Reset (F3-40) will be required after power reset

Caution
By changing of DIP SW 4-2 to ON, the Back-up operation can start when the active outdoor unit exists on the multi outdoor unit connection. (Stand alone outdoor unit is impossible)
The following conditions will be concerned in use of back-up operation. (Please do not use the system with back-up operation for long time.)

- The operating compressor life time becomes shorter.
- The operating performance may drop due to the limited active compressor(s).
- The compressor may stop frequently by protection controlling.

*In order to keep the operating capacity, the release of the Low noise mode setting might be necessary.

Trouble shooting 48 **E86. 1**
OUTDOOR UNIT Error Method:
Discharge Pressure Sensor Error

Indicate or Display:

Outdoor Unit : E. 8 6. 1
Indoor Unit : Operation LED 9 times Flash, Timer LED 15 Times Flash,
 Filter LED Continuous Flash.
Error Code : 9 U / 8 6

Detective Actuators:

Discharge pressure sensor

Detective details:

- When any of the following conditions is satisfied, a discharge pressure sensor error is generated.
 1. 30 seconds or more have elapsed since the outdoor unit power was turned on and pressure sensor detected value < 0.3V continued for 30 seconds or more
 2. 30 seconds or more have elapsed since the outdoor unit power was turned on and pressure sensor detected value \geq 5.0V was detected.

Forecast of Cause :

1. Discharge pressure sensor connector disconnection, open
2. Discharge pressure sensor defective
3. Main PCB defective

Check Point 1 : Check the discharge pressure sensor connection state

- Connector connection state check
- Cable open check



Check Point 2 : Check the discharge pressure sensor

- Sensor characteristics check
 * For the characteristics of the discharge pressure sensor, refer to the "Service Parts Information 23".



Check Point 3 : Check voltage of Main PCB (DC5.0V)

- Main PCB (CN118:1-3) voltage value = 5V
Remove the sensor from Main PCB, check the voltage.

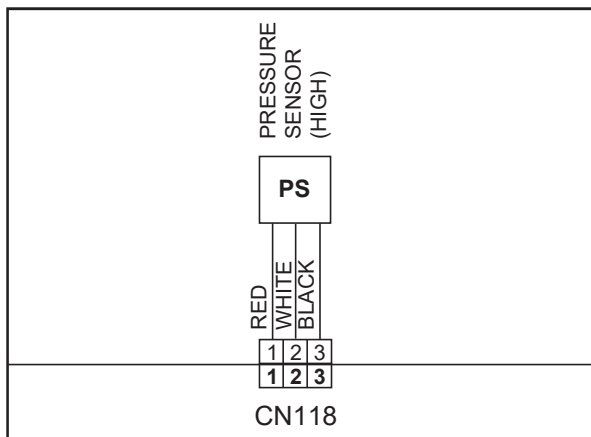

Discharge pressure sensor (CN118:1-3)

► **If the voltage does not appear, replace Main PCB and set up original address.**



Caution

By changing of DIP SW 4-2 to ON, the Back-up operation can start when the active outdoor unit exists on the multi outdoor unit connection. (Stand alone outdoor unit is impossible)

The following conditions will be concerned in use of back-up operation. (Please do not use the system with back-up operation for long time.)

- The operating compressor life time becomes shorter.
- The operating performance may drop due to the limited active compressor(s).
- The compressor may stop frequently by protection controlling.

*In order to keep the operating capacity, the release of the Low noise mode setting might be necessary.

Trouble shooting 49 E86. 3 OUTDOOR UNIT Error Method: Suction Pressure Sensor Error	Indicate or Display: Outdoor Unit : E. 8 6. 3 Indoor Unit : Operation LED 9 times Flash, Timer LED 15 Times Flash, Filter LED Continuous Flash. Error Code : 9 U / 8 6

Detective Actuators: Suction pressure sensor	Detective details: <ul style="list-style-type: none"> When any of the following conditions is satisfied, a suction pressure sensor error is generated. <ol style="list-style-type: none"> 30 seconds or more have elapsed since the outdoor unit power was turned on and pressure sensor detected value < 0.06V continued for 30 seconds or more. 30 seconds or more have elapsed since the outdoor unit power was turned on and pressure sensor detected value \geq 5.0V was detected.
--	---

Forecast of Cause : <ol style="list-style-type: none"> Suction pressure sensor connector disconnection, open Suction pressure sensor defective Main PCB defective

Check Point 1 : Check the suction pressure sensor connection state
<input type="checkbox"/> Connector connection state check <input type="checkbox"/> Cable open check



Check Point 2 : Check the suction pressure sensor
<input type="checkbox"/> Sensor characteristics check * For the characteristics of the suction pressure sensor, refer to the "Service Parts Information 23".



Check Point 3 : Check voltage of Main PCB (DC5.0V)	
<input type="checkbox"/> Main PCB (CN119:1-3) voltage value = 5V Remove the sensor from Main PCB, check the voltage.	
Suction pressure sensor (CN119:1-3)	
▶ If the voltage does not appear, replace Main PCB and set up original address.	

Caution By changing of DIP SW 4-2 to ON, the Back-up operation can start when the active outdoor unit exists on the multi outdoor unit connection. (Stand alone outdoor unit is impossible) The following conditions will be concerned in use of back-up operation. (Please do not use the system with back-up operation for long time.) <ul style="list-style-type: none"> - The operating compressor life time becomes shorter. - The operating performance may drop due to the limited active compressor(s). - The compressor may stop frequently by protection controlling. *In order to keep the operating capacity, the release of the Low noise mode setting might be necessary.

Trouble shooting 50 OUTDOOR UNIT Error Method: High Pressure Switch 1 Error	E86. 4	Indicate or Display: Outdoor Unit : E. 8 6. 4 Indoor Unit : Operation LED 9 times Flash, Timer LED 15 Times Flash, Filter LED Continuous Flash. Error Code : 9 U / 8 6
--	---------------	---

Detective Actuators: High pressure switch 1	Detective details: <ul style="list-style-type: none"> • When the power was turned on, "high pressure switch 1: open" was detected.
---	---

Forecast of Cause :	1. High pressure switch 1 connector disconnection, open 2. High pressure switch 1 characteristics defective 3. Main PCB defective
----------------------------	---

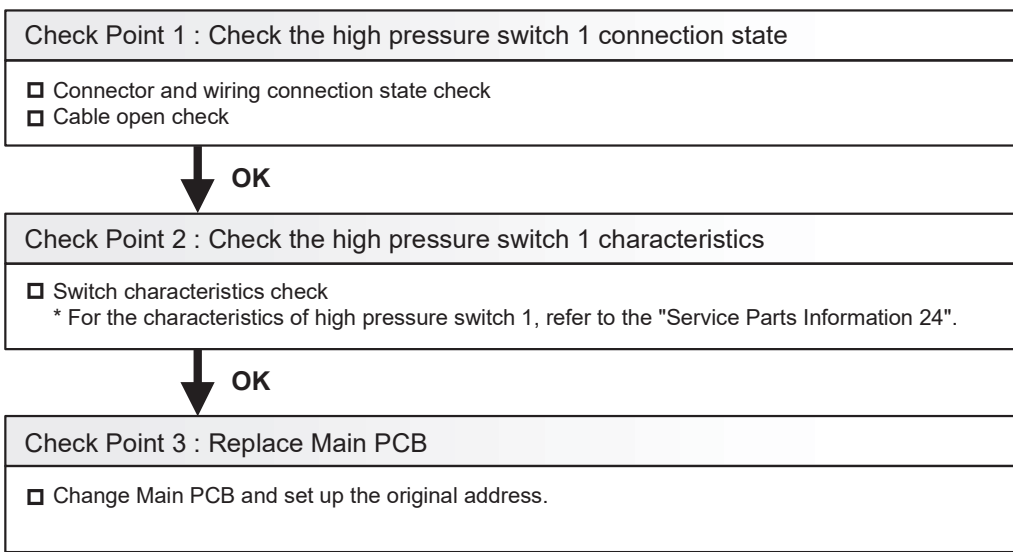

Caution
By changing of DIP SW 4-2 to ON, the Back-up operation can start when the active outdoor unit exists on the multi outdoor unit connection.
(Stand alone outdoor unit is impossible)
The following conditions will be concerned in use of back-up operation. (Please do not use the system with back-up operation for long time.)

- The operating compressor life time becomes shorter.
- The operating performance may drop due to the limited active compressor(s).
- The compressor may stop frequently by protection controlling.

*In order to keep the operating capacity, the release of the Low noise mode setting might be necessary.

Trouble shooting 51 E93. 1 OUTDOOR UNIT Error Method: Inverter Compressor Start UP Error	Indicate or Display: Outdoor Unit : E. 9 3. 1 Indoor Unit : Operation LED 9 times Flash, Timer LED 15 Times Flash, Filter LED Continuous Flash. Error Code : 9 U / 9 3
--	---

Detective Actuators: Inverter PCB	Detective details: <ul style="list-style-type: none"> ▪ "Protection stop by "overcurrent generation at inverter compressor starting" ⇒ restart" generated consecutively 60 times x 2 sets (total 120 times) * The shortest time up to error generation is about 130 minutes * Restart is not performed if an indoor unit in the same refrigerant system is not turned ON by thermostat. * After the end of the 1st set, the 2nd set is not started if all the compressors in the same refrigerant system are not temporarily stopped.
---	--

Forecast of Cause :	1. Inverter PCB to inverter compressor wiring disconnection, open 2. Inverter PCB defective 3. Inverter compressor defective (lock, winding short)
----------------------------	--

Check Point 1 : Check the Inverter PCB to inverter compressor connection state
<input type="checkbox"/> Wiring connection state check <input type="checkbox"/> Cable open check



Check Point 2 : Check the Inverter PCB
<input type="checkbox"/> Inverter PCB check (Refer to Service Parts Information 4)



Check Point 3 : Replace the Inverter compressor
<input type="checkbox"/> Inverter compressor replacement

After fixing the problem and for canceling the Error, Error Reset (F3-40) will be required after power reset

<p>Caution By changing of DIP SW 4-2 to ON, the Back-up operation can start when the active outdoor unit exists on the multi outdoor unit connection. (Stand alone outdoor unit is impossible) The following conditions will be concerned in use of back-up operation. (Please do not use the system with back-up operation for long time.)</p> <ul style="list-style-type: none"> - The operating compressor life time becomes shorter. - The operating performance may drop due to the limited active compressor(s). - The compressor may stop frequently by protection controlling. <p>*In order to keep the operating capacity, the release of the Low noise mode setting might be necessary.</p>

Trouble shooting 52 OUTDOOR UNIT Error Method: Trip Detection	E94. 1	Indicate or Display: Outdoor Unit : E. 9 4. 1 Indoor Unit : Operation LED 9 times Flash, Timer LED 15 Times Flash, Filter LED Continuous Flash. Error Code : 9 U / 9 4
--	---------------	---

Detective Actuators: Inverter PCB	Detective details: <ul style="list-style-type: none"> ▪ "Protection stop by "overcurrent generation after inverter compressor start processing completed"" generated consecutively 5 times. * The number of generations is reset if protection stop is not generated again within 40 seconds after restarting.
---	--

Forecast of Cause :	<ol style="list-style-type: none"> 1. Outdoor unit fan operation defective, foreign matter on hear exchanger, excessive rise of ambient temperature 2. Inverter PCB defective 3. Inverter compressor defective (lock, winding short)
----------------------------	---

Check Point 1 : Check the outdoor unit fan operation, heat exchanger, ambient temperature

- No obstructions in air passages?
- Heat exchange fins clogged
- Outdoor unit fan motor check
- Ambient temperature not raised by the effect of other heat sources?
- Discharged air not sucked in?

↓
OK

Check Point 2 : Check the Inverter PCB

- Inverter PCB check (Refer to Service Parts Information 4)

↓
OK

Check Point 3 : Replace the Inverter compressor

- Inverter compressor replacement

After fixing the problem and for canceling the Error, Error Reset (F3-40) will be required after power reset

Caution
 By changing of DIP SW 4-2 to ON, the Back-up operation can start when the active outdoor unit exists on the multi outdoor unit connection. (Stand alone outdoor unit is impossible)
 The following conditions will be concerned in use of back-up operation. (Please do not use the system with back-up operation for long time.)

- The operating compressor life time becomes shorter.
- The operating performance may drop due to the limited active compressor(s).
- The compressor may stop frequently by protection controlling.

*In order to keep the operating capacity, the release of the Low noise mode setting might be necessary.

Trouble shooting 53 OUTDOOR UNIT Error Method: Compressor Motor Loss of Synchronization	E95. 5	<u>Indicate or Display:</u> Outdoor Unit : E. 9 5. 5 Indoor Unit : Operation LED 9 times Flash, Timer LED 15 Times Flash, Filter LED Continuous Flash. Error Code : 9 U / 9 5
--	---------------	---

<u>Detective Actuators:</u> Inverter PCB	<u>Detective details:</u> <ul style="list-style-type: none"> ▪ "Protection stop by "loss of synchronization detection"" generated consecutively 5 times * The number of generations is reset if protection stop is not generated again within 40 seconds after restarting.
---	---

<u>Forecast of Cause :</u>	1. Inverter PCB defective 2. Inverter compressor defective (lock)
----------------------------	--

Check Point 1 : Check the Inverter PCB
<input type="checkbox"/> Inverter PCB check (Refer to Service Parts Information 4)



Check Point 2 : Replace the Inverter compressor
<input type="checkbox"/> Inverter compressor replacement

After fixing the problem and for canceling the Error, Error Reset (F3-40) will be required after power reset

Caution
 By changing of DIP SW 4-2 to ON, the Back-up operation can start when the active outdoor unit exists on the multi outdoor unit connection. (Stand alone outdoor unit is impossible)
 The following conditions will be concerned in use of back-up operation. (Please do not use the system with back-up operation for long time.)

- The operating compressor life time becomes shorter.
- The operating performance may drop due to the limited active compressor(s).
- The compressor may stop frequently by protection controlling.

*In order to keep the operating capacity, the release of the Low noise mode setting might be necessary.

Trouble shooting 54 E97. 1 OUTDOOR UNIT Error Method: Outdoor Unit Fan Motor Lock Error	Indicate or Display: Outdoor Unit : E. 9 7. 1 Indoor Unit : Operation LED 9 times Flash, Timer LED 15 Times Flash, Filter LED Continuous Flash. Error Code : 9 U / 9 7
---	---

Detective Actuators: Outdoor unit fan motor	Detective details: 1. When outdoor fan rotation speed is less than 100rpm in 20 seconds after fan motor starts, fan motor and compressor stops. 2. After fan motor restarts, if the same operation is repeated consecutively 4 times, fan motor and compressor stops permanently.
---	--

Forecast of Cause :	1. Rotation obstruction by foreign matter 2. Main PCB to Driver PCB to Fan motor wiring, disconnection, open 3. Fan motor defective (winding open, lock) 4. Driver PCB defective 5. Main PCB defective
----------------------------	--

Check Point 1 : Fan rotation state check
<input type="checkbox"/> Check for the absence of foreign matter around the fan.



Check Point 2 : Main PCB to Driver PCB to Fan motor wiring connection state
<input type="checkbox"/> Connector and wiring connection state check. <input type="checkbox"/> Check blown fuse of DC FAN motor (5A FUSE) <input type="checkbox"/> Cable open check. Refer to the service parts information 5



Check Point 3 : Fan motor defective
<input type="checkbox"/> Check if fan can be rotated by hand. <input type="checkbox"/> Motor winding resistance check <input type="checkbox"/> Motor operation check Refer to the service parts information 22



Check Point 4 : Replace Driver PCB
<input type="checkbox"/> Check the appearance of Driver PCB. <input type="checkbox"/> Change Driver PCB and release the error. Check if the error reoccurs on a test run.



Check Point 5 : Replace Main PCB
<input type="checkbox"/> Change Main PCB and release the error. Check if the error reoccurs on a test run. >> If it is abnormal, replace Main PCB. (When Main PCB is replaced, set up the original setting by Rotary, Dip, and Push SW)

After fixing the problem and for canceling the Error, Error Reset (F3-40) will be required after power reset

Caution By changing of DIP SW 4-2 to ON, the Back-up operation can start when the active outdoor unit exists on the multi outdoor unit connection. (Stand alone outdoor unit is impossible) The following conditions will be concerned in use of back-up operation. (Please do not use the system with back-up operation for long time.) - The operating compressor life time becomes shorter. - The operating performance may drop due to the limited active compressor(s). - The compressor may stop frequently by protection controlling. *In order to keep the operating capacity, the release of the Low noise mode setting might be necessary.
--

Trouble shooting 55 E97. 5 OUTDOOR UNIT Error Method: Outdoor Unit Fan Motor Temp. Abnormal	Indicate or Display: Outdoor Unit : E. 9 7. 5 Indoor Unit : Operation LED 9 times Flash, Timer LED 15 Times Flash, Filter LED Continuous Flash. Error Code : 9 U / 9 7
---	---

Detective Actuators: Driver PCB	Detective details: 1. When outdoor fan motor cannot operate more than 470rpm, fan motor and compressor stops. 2. After fan motor restarts, if fan motor cannot operate at 470rpm or more, or the same operation is repeated consecutively 3 times within 60 minutes, fan motor and compressor stops permanently.
---	---

Forecast of Cause :	1. Rotation obstructed by foreign matter 2. Ventilation obstructed by heat exchange foreign matter 3. Excessive ambient temperature rise 4. Static pressure setting incorrect, specified static pressure value exceeded 5. Driver PCB defective
----------------------------	---

Check Point 1 : Check fan rotation state
<input type="checkbox"/> Check for the absence of foreign matter around the fan

↓ **OK**

Check Point 2 : Check for obstruction of ventilation by heat exchange foreign matter
<input type="checkbox"/> Check for foreign matter on heat exchanger

↓ **OK**

Check Point 3 : Check the ambient temperature
<input type="checkbox"/> Ambient temperature not raised by the effect of other heat sources? <input type="checkbox"/> Discharged air not sucked in?

↓ **OK**

Check Point 4 : Check the static pressure
<input type="checkbox"/> Check if static pressure is set correctly. <input type="checkbox"/> Check if static pressure is not higher than the specified value.

↓ **OK**

Check Point 5 : Replace Driver PCB
<input type="checkbox"/> Check the appearance and condition of mounting of Driver PCB. <input type="checkbox"/> Change Driver PCB and release the error. Refer to the service parts info 5 Check if the error reoccurs on a test run.

After fixing the problem and for canceling the Error, Error Reset (F3-40) will be required after power reset

Caution
By changing of DIP SW 4-2 to ON, the Back-up operation can start when the active outdoor unit exists on the multi outdoor unit connection. (Stand alone outdoor unit is impossible)
The following conditions will be concerned in use of back-up operation. (Please do not use the system with back-up operation for long time.)
- The operating compressor life time becomes shorter.
- The operating performance may drop due to the limited active compressor(s).
- The compressor may stop frequently by protection controlling.
*In order to keep the operating capacity, the release of the Low noise mode setting might be necessary.

Trouble shooting 56 OUTDOOR UNIT Error Method: Outdoor Unit Fan Motor Driver Abnormal	E97. 9	Indicate or Display: Outdoor Unit : E. 9 7. 9 Indoor Unit : Operation LED 9 times Flash, Timer LED 15 Times Flash, Filter LED Continuous Flash. Error Code : 9 U / 9 7
--	---------------	---

<u>Detective Actuators:</u> Driver PCB Fan motor Main PCB	<u>Detective details:</u> When Driver PCB detects the following abnormalities, the error signal is output. <ul style="list-style-type: none"> • Driver PCB defective • Fan motor defective (Layer short) • Main PCB defective (DC output abnormal) • Lose connection or disconnecting wire
---	--

<u>Forecast of Cause :</u>	1. Driver PCB defective 2. Fan motor defective 3. Main PCB defective 4. Lose connection or disconnecting wire
-----------------------------------	--

Check Point 1 : Check the wiring connection
<input type="checkbox"/> Check Fan motor to Driver PCB wiring connector disconnection, open <input type="checkbox"/> Check blown fuse of DC FAN motor (5A FUSE) <input type="checkbox"/> Check Driver PCB to Capacitor wiring connector disconnection, open <input type="checkbox"/> Check Main PCB to Driver PCB wiring connector disconnection, open



Check Point 2 : Check DC input power of Driver PCB
<input type="checkbox"/> Check the DC voltage of CN759 is within 15V± 10%. Refer to the service parts info 5 >> If it is abnormal, replace Main PCB. (When Main PCB is replaced, set up the original setting by Rotary, Dip, and Push SW)



Check Point 3 : Replace Driver PCB
<input type="checkbox"/> Check the appearance and condition of mounting of Driver PCB. <input type="checkbox"/> Change Driver PCB and release the error. Check if the error reoccurs on a test run.



Check Point 4 : Replace Fan motor
<input type="checkbox"/> Check the winding resistance of Fan motor. <input type="checkbox"/> Change Fan motor and check if the error reoccurs on a test run.

After fixing the problem and for canceling the Error, Error Reset (F3-40) will be required after power reset

Caution
By changing of DIP SW 4-2 to ON, the Back-up operation can start when the active outdoor unit exists on the multi outdoor unit connection. (Stand alone outdoor unit is impossible)
The following conditions will be concerned in use of back-up operation. (Please do not use the system with back-up operation for long time.)
- The operating compressor life time becomes shorter.
- The operating performance may drop due to the limited active compressor(s).
- The compressor may stop frequently by protection controlling.
*In order to keep the operating capacity, the release of the Low noise mode setting might be necessary.

Trouble shooting 57 E9A.1 OUTDOOR UNIT Error Method: Coil 1 (EEV) Error	Indicate or Display: Outdoor Unit : E. 9 A. 1 Indoor Unit : Operation LED 9 times Flash, Timer LED 15 Times Flash, Filter LED Continuous Flash. Error Code : 9 U / 9 A
---	---

Detective Actuators: Main PCB	Detective details: Coil 1(Expansion valve 1) driver circuit open detected.
---	--

Forecast of Cause :	1. EEV1 coil loose connection 2. EEV1 wires cut or pinched. 3. Defective EEV1 coil 4. Main PCB (DC12V) output abnormal
----------------------------	---

Check Point 1 : Check the connection of EEV connector

Check if the connector CN116 is loose connection or not.

↓ **OK**

Check Point 2 : Check the EEV wire

Check if the wire of EEV1 has damage or not. (Slash, Braking of wire, Pinching, etc.)

NG → Replace EEV1 Coil

↓ **OK**

Check Point 3 : Check the EEV Coil

Check if the circuit of EEV1 coil winding is good or not. (Refer to the service parts information 15.)

NG → Replace EEV1 Coil

↓ **OK**

Check Point 4 : Check the output of EEV on the Main PCB

Check if the DC12V is on between the Pin No.1 of CN116 and Pin No.2 of CN132 (GND). (Disconnect the wire of EEV1 when you check the output of EEV1)

↓ **NG**

Replace Main PCB

↓ **OK**

Check Point 5 : Noise, momentary open, voltage drop

Check if temporary voltage drop was not generated.
 Check if momentary open was not generated.
 Check if ground is connection correctly or there are no related cables near the power line.

Trouble shooting 58 E9A.2 OUTDOOR UNIT Error Method: Coil 2 (EEV) Error	Indicate or Display: Outdoor Unit : E. 9 A. 2 Indoor Unit : Operation LED 9 times Flash, Timer LED 15 Times Flash, Filter LED Continuous Flash. Error Code : 9 U / 9A
---	--

<u>Detective Actuators:</u> Main PCB	<u>Detective details:</u> Coil 2(Expansion valve 2) driver circuit open detected.
--	---

<u>Forecast of Cause :</u>	1. EEV2 coil loose connection 2. EEV2 wires cut or pinched. 3. Defective EEV2 coil 4. Main PCB (DC12V) output abnormal
-----------------------------------	---

Check Point 1 : Check the connection of EEV connector

Check if the connector CN117 is loose connection or not.

↓ **OK**

Check Point 2 : Check the EEV wire

Check if the wire of EEV2 has damage or not. (Slash, Braking of wire, Pinching, etc.)

NG → Replace EEV2 Coil

↓ **OK**

Check Point 3 : Check the EEV Coil

Check if the circuit of EEV2 coil winding is good or not. (Refer to the service parts information 16.)

NG → Replace EEV2 Coil

↓ **OK**

Check Point 4 : Check the output of EEV on the Main PCB

Check if the DC12V is on between the Pin No.1 of CN117 and Pin No.2 of CN132 (GND). (Disconnect the wire of EEV2 when you check the output of EEV2)

↓ **NG**

Replace Main PCB

↓ **OK**

Check Point 5 : Noise, momentary open, voltage drop

Check if temporary voltage drop was not generated.
 Check if momentary open was not generated.
 Check if ground is connection correctly or there are no related cables near the power line.

Trouble shooting 59 OUTDOOR UNIT Error Method: Coil 3 (EEV) Error	E9A.3	Indicate or Display: Outdoor Unit : E. 9 A. 3 Indoor Unit : Operation LED 9 times Flash, Timer LED 15 Times Flash, Filter LED Continuous Flash. Error Code : 9 U / 9 A
--	--------------	---

<u>Detective Actuators:</u> Main PCB	<u>Detective details:</u> Coil 3(Expansion valve 3) driver circuit open detected.
--	---

<u>Forecast of Cause :</u>	1. EEV3 coil loose connection 2. EEV3 wires cut or pinched. 3. Defective EEV3 coil 4. Main PCB (DC12V) output abnormal
-----------------------------------	---

Check Point 1 : Check the connection of EEV connector

Check if the connector CN160 is loose connection or not.

↓
OK

Check Point 2 : Check the EEV wire

Check if the wire of EEV3 has damage or not. (Slash, Braking of wire, Pinching, etc.)

NG → Replace EEV3 Coil

↓
OK

Check Point 3 : Check the EEV Coil

Check if the circuit of EEV3 coil winding is good or not. (Refer to the service parts information 17.)

NG → Replace EEV3 Coil

↓
OK

Check Point 4 : Check the output of EEV on the Main PCB

Check if the DC12V is on between the Pin No.1 of CN160 and Pin No.2 of CN132 (GND). (Disconnect the wire of EEV3 when you check the output of EEV3)

↓
NG

Replace Main PCB

↓
OK

Check Point 5 : Noise, momentary open, voltage drop

Check if temporary voltage drop was not generated.
 Check if momentary open was not generated.
 Check if ground is connection correctly or there are no related cables near the power line.

Trouble shooting 60 E9U.2 <u>OUTDOOR UNIT Error Method:</u> Slave Outdoor Unit Error	<u>Indicate or Display:</u> Outdoor Unit : E. 9 U. 2 (Only for master outdoor unit) Indoor Unit : No display / Operation LED 9 times Flash, Timer LED 15 time Flash Filter LED Continuous Flash Error Code : *
--	--

* Master Outdoor unit : 9 U. 2 /
Slave Outdoor unit and Service Tool indicate applicable Error code

<u>Detective Actuators:</u> Slave Unit	<u>Detective details:</u> <ul style="list-style-type: none"> ▪ Error signal received from slave unit of same refrigerant system
--	--

Check Point 1 : Check the slave unit
<input type="checkbox"/> Slave unit 7 seg display check ⇒ Check by troubleshooting based on displayed error code.

Trouble shooting 61 EA1. 1 OUTDOOR UNIT Error Method: Discharge Temperature 1 Abnormal	Indicate or Display: Outdoor Unit : E. A 1. 1 Indoor Unit : Operation LED 9 times Flash, Timer LED 15 Times Flash, Filter LED Continuous Flash. Error Code : 9 U / A 1
--	--

Detective Actuators: Discharge temp. sensor 1	Detective details: ▪ "Protection stop by "discharge temp. 1 $\geq 115^{\circ}\text{C}$ (239°F) during compressor 1 operation"" generated 2 times within 40 minutes.
---	---

Forecast of Cause :	1. 3-way valve not opened 2. EEV defective, strainer clogged 3. Outdoor unit operation defective, foreign matter on heat exchanger 4. Discharge temp. sensor 1 defective 5. Insufficient refrigerant
----------------------------	--

<Cooling/ Cooling main operation>

Check Point 1 : Check if 3-way valve is open.
<input type="checkbox"/> If the 3-way valve was closed, open the 3-way valve and check operation.

↓
OK

Check Point 2 : Check the EEV, strainer
<input type="checkbox"/> EEV (EEV1, EEV2, EEV3, indoor unit EEV) open? <input type="checkbox"/> Strainer clogging check (before and after EEV, ACM oil return) Refer to "Service Parts Information 15, 16, 17".

↓
OK

Check Point 3 : Check the outdoor unit fan, heat exchanger
<input type="checkbox"/> Check for foreign matter at heat exchanger <input type="checkbox"/> Check if fan can be rotated by hand. <input type="checkbox"/> Motor check

↓
OK

Check Point 4 : Check the discharge temp. sensor 1
<input type="checkbox"/> Discharge temp. sensor 1 characteristics check (Check by disconnecting sensor from PCB.) * For the characteristics of the sensor, refer to the "Service Parts Information 25".

↓
OK

Check Point 5 : Check the refrigerant amount
<input type="checkbox"/> Leak check

<Heating/ Heating main operation>

Check Point 1 : Check if 3-way valve is open.
<input type="checkbox"/> If the 3-way valve was closed, open the 3-way valve and check operation.

↓
OK

Check Point 2 : Check the EEV, strainer
<input type="checkbox"/> EEV (EEV1, EEV2, EEV3) open? <input type="checkbox"/> Strainer clogging check (before and after EEV, ACM oil return) Refer to "Service Parts Information 15, 16, 17".

↙
OK

After fixing the problem and for canceling the Error, Error Reset (F3-40) will be required after power reset

Caution
By changing of DIP SW 4-2 to ON, the Back-up operation can start when the active outdoor unit exists on the multi outdoor unit connection. (Stand alone outdoor unit is impossible)
The following conditions will be concerned in use of back-up operation. (Please do not use the system with back-up operation for long time.)
- The operating compressor life time becomes shorter.
- The operating performance may drop due to the limited active compressor(s).
- The compressor may stop frequently by protection controlling.
*In order to keep the operating capacity, the release of the Low noise mode setting might be necessary.

Trouble shooting 62 EA3. 1 OUTDOOR UNIT Error Method: Compressor 1 Temperature Abnormal	Indicate or Display: Outdoor Unit : E. A 3. 1 Indoor Unit : Operation LED 9 times Flash, Timer LED 15 Times Flash, Filter LED Continuous Flash. Error Code : 9 U / A 3
---	---

Detective Actuators: Compressor temp. sensor 1	Detective details: ▪ "Protection stop by "compressor 1 temp. $\geq 15^{\circ}\text{C}$ (239°F)during compressor 1 operation"" generated 2 times within 40 minutes.
--	--

Forecast of Cause :	<ol style="list-style-type: none"> 1. 3-way valve not opened 2. EEV defective, strainer clogged 3. Outdoor unit operation defective, foreign matter on heat exchanger 4. Compressor 1 temp. sensor defective 5. Insufficient refrigerant
----------------------------	---

<Cooling/ Cooling main operation>

Check Point 1 : Check if 3-way valve is open.
<input type="checkbox"/> If the 3-way valve was closed, open the 3-way valve and check operation.

OK

Check Point 2 : Check the EEV, strainer
<input type="checkbox"/> EEV (EEV1, EEV2, EEV3, indoor unit EEV) open? <input type="checkbox"/> Strainer clogging check (before and after EEV, ACM oil return) Refer to "Service Parts Information 15, 16, 17".

OK

Check Point 3 : Check the outdoor unit fan,heat exchanger
<input type="checkbox"/> Check for foreign matter at heat exchanger <input type="checkbox"/> Check if fan can be rotated by hand. <input type="checkbox"/> Motor check

OK

Check Point 4 : Check the compressor 1 temp. sensor
<input type="checkbox"/> Compressor 1 temp. sensor characteristics check (Check by disconnecting sensor from PCB.) * For the characteristics of the sensor, refer to the "Service Parts Information 25".

OK

Check Point 5 : Check the refrigerant amount
<input type="checkbox"/> Leak check

<Heating/ Heating main operation>

Check Point 1 : Check if 3-way valve is open.
<input type="checkbox"/> If the 3-way valve was closed, open the 3-way valve and check operation.

OK

Check Point 2 : Check the EEV, strainer
<input type="checkbox"/> EEV (EEV1, EEV2, EEV3) open? <input type="checkbox"/> Strainer clogging check (before and after EEV, ACM oil return) Refer to "Service Parts Information 15, 16, 17".

OK

After fixing the problem and for canceling the Error, Error Reset (F3-40) will be required after power reset

Caution
By changing of DIP SW 4-2 to ON, the Back-up operation can start when the active outdoor unit exists on the multi outdoor unit connection. (Stand alone outdoor unit is impossible)
The following conditions will be concerned in use of back-up operation. (Please do not use the system with back-up operation for long time.)
- The operating compressor life time becomes shorter.
- The operating performance may drop due to the limited active compressor(s).
- The compressor may stop frequently by protection controlling.
*In order to keep the operating capacity, the release of the Low noise mode setting might be necessary.

Trouble shooting 63 EA4. 1 OUTDOOR UNIT Error Method: High Pressure Abnormal	Indicate or Display: Outdoor Unit : E. A 4. 1 Indoor Unit : Operation LED 9 times Flash, Timer LED 15 Times Flash, Filter LED Continuous Flash. Error Code : 9 U / A 4

Detective Actuators: Judgment from value sensed by discharge pressure sensor	Detective details: ▪ "Protection stop by "discharge pressure \geq 580psi(4.00MPa)during operation of any compressor"" generated 3 times within 60 minutes
--	---

Forecast of Cause :	1. 3-way valve not opened 2. Outdoor unit fan operation defective, foreign matter at heat exchanger, excessive ambient temperature rise 3. EEV defective, strainer clogged 4. Solenoid valve defective 5. 4-way valve (including a coil) defective 6. Discharge pressure sensor defective 7. Refrigerant overcharged
----------------------------	--

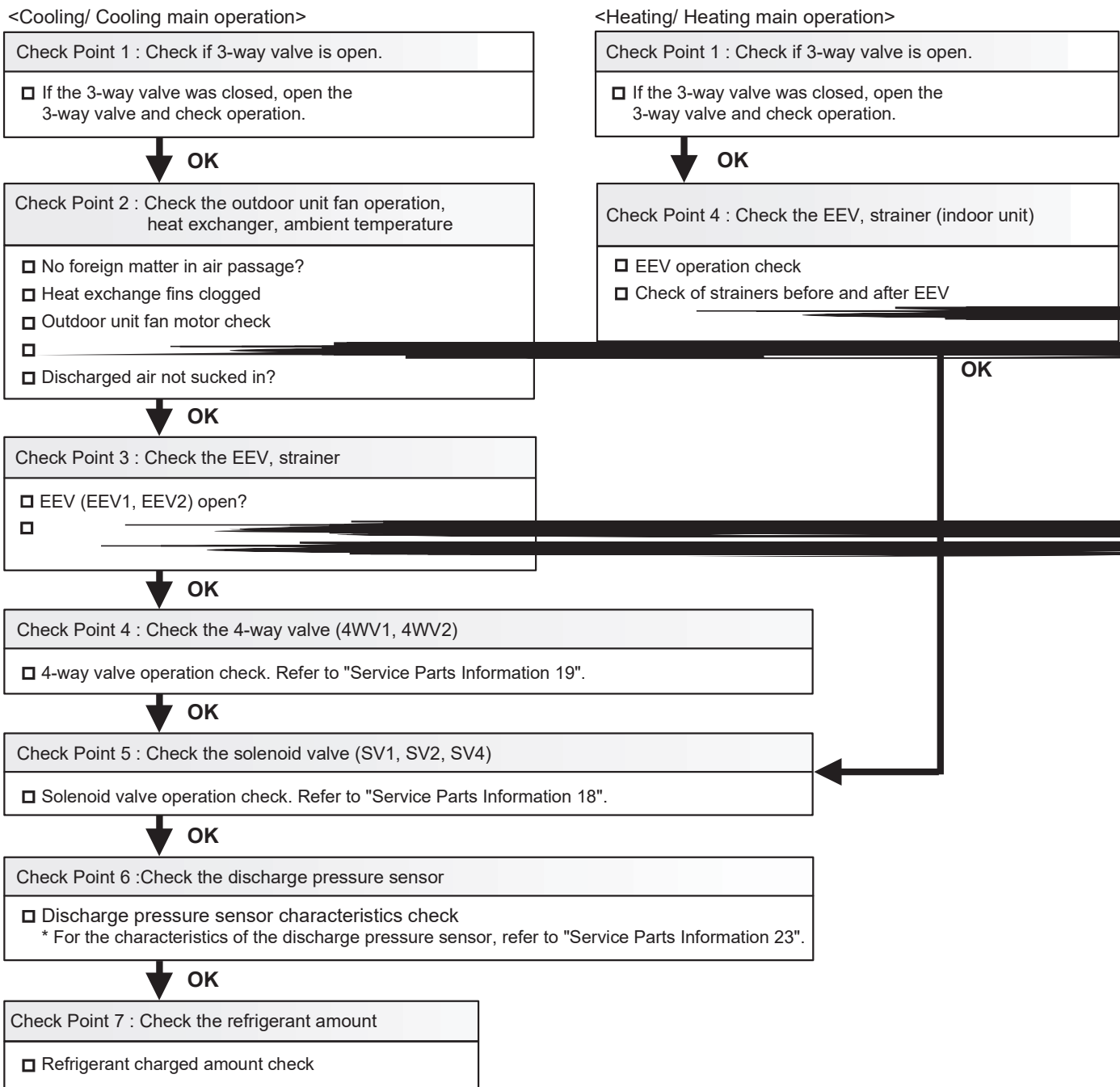

Caution
 By changing of DIP SW 4-2 to ON, the Back-up operation can start when the active outdoor unit exists on the multi outdoor unit connection. (Stand alone outdoor unit is impossible)
 The following conditions will be concerned in use of back-up operation. (Please do not use the system with back-up operation for long time.)
 - The operating compressor life time becomes shorter.
 - The operating performance may drop due to the limited active compressor(s).
 - The compressor may stop frequently by protection controlling.
 *In order to keep the operating capacity, the release of the Low noise mode setting might be necessary.

Trouble shooting 64 EA4. 2 OUTDOOR UNIT Error Method: High Pressure Protection 1	Indicate or Display: Outdoor Unit : E. A 4. 2 Indoor Unit : Operation LED 9 times Flash, Timer LED 15 Times Flash, Filter LED Continuous Flash. Error Code : 9U / A 4
---	--

Detective Actuators: High pressure switch 1	Detective details: "Protection stop by "high pressure switch 1 operated during compressor 1 operation"" generated 3 times within 60 minutes
---	---

Forecast of Cause :	1. 3-way valve not opened 2. Outdoor unit fan operation defective, foreign matter at heat exchanger, excessive ambient temperature rise 3. Check valve clogge 4. EEV defective, strainer clogged 5. Solenoid valve defective 6. 4-way valve (including a coil) defective 7. High pressure switch 1 defective 8. Refrigerant overcharged
----------------------------	--

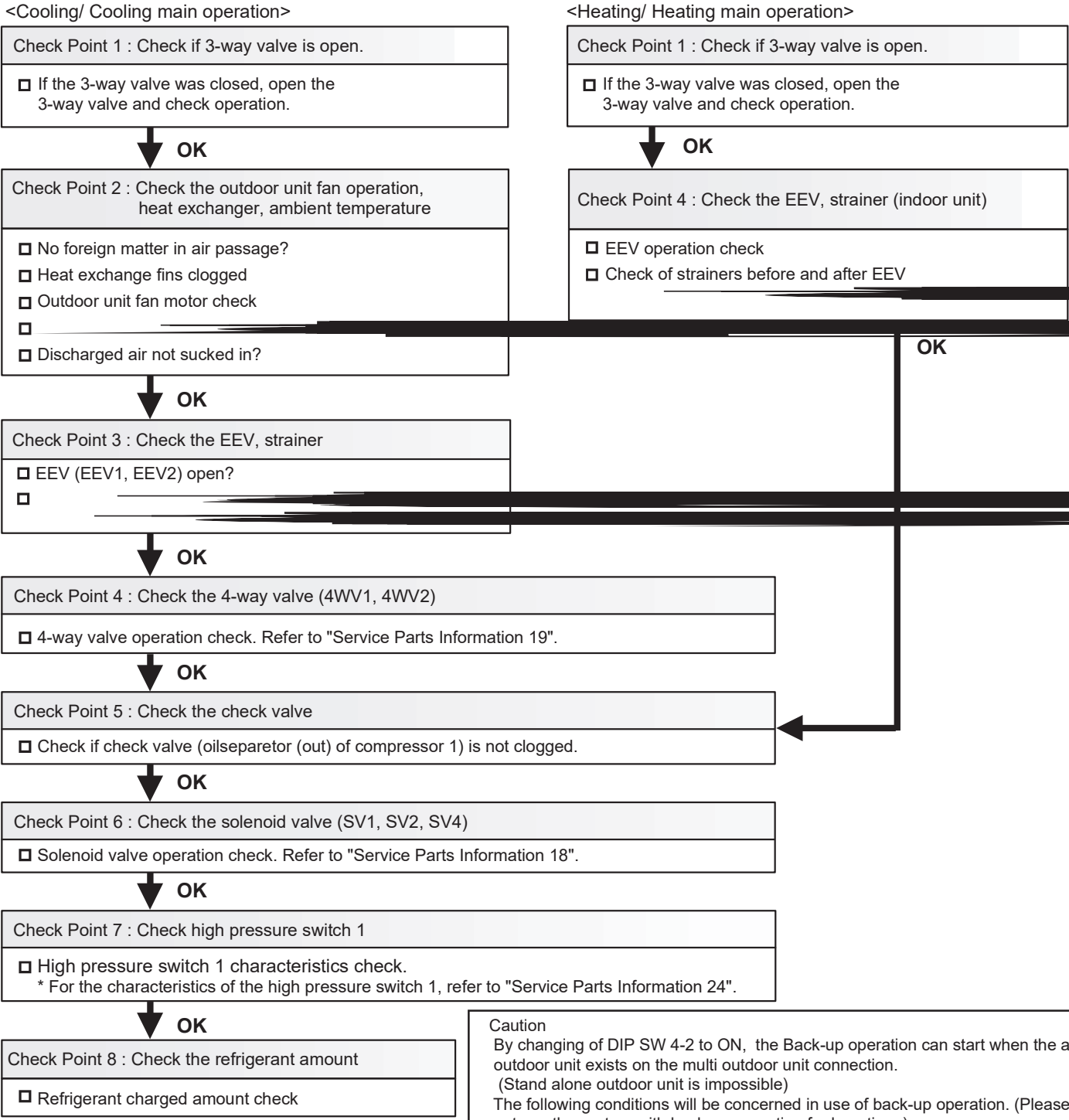

Caution
 By changing of DIP SW 4-2 to ON, the Back-up operation can start when the active outdoor unit exists on the multi outdoor unit connection.
 (Stand alone outdoor unit is impossible)
 The following conditions will be concerned in use of back-up operation. (Please do not use the system with back-up operation for long time.)
 - The operating compressor life time becomes shorter.
 - The operating performance may drop due to the limited active compressor(s).
 - The compressor may stop frequently by protection controlling.
 *In order to keep the operating capacity, the release of the Low noise mode setting might be necessary.

Trouble shooting 65 OUTDOOR UNIT Error Method: Low Pressure Abnormal	EA5. 1	Indicate or Display:
		Outdoor Unit : E. A 5. 1 Indoor Unit : Operation LED 9 times Flash, Timer LED 15 Times Flash, Filter LED Continuous Flash. Error Code : 9 U / A 6

Detective Actuators: Suction pressure sensor	Detective details: ▪ "Protection stop by "suction pressure \leq 15psi (0.10MPa) continued for 10 minutes" or "suction pressure \leq 7.25psi(0.05MPa)" during operation of any compressor"" was generated 5 times within 3 hours
--	---

Forecast of Cause :	1. 3-way valve not opened 2. Outdoor unit ambient temperature too low 3. Outdoor unit fan operation defective, foreign matter at heat exchanger 4. EEV defective, strainer clogged 5. Solenoid valve defective 6. 4-way valve defective 7. Low pressure sensor characteristics defective 8. Insufficient refrigerant
----------------------------	---

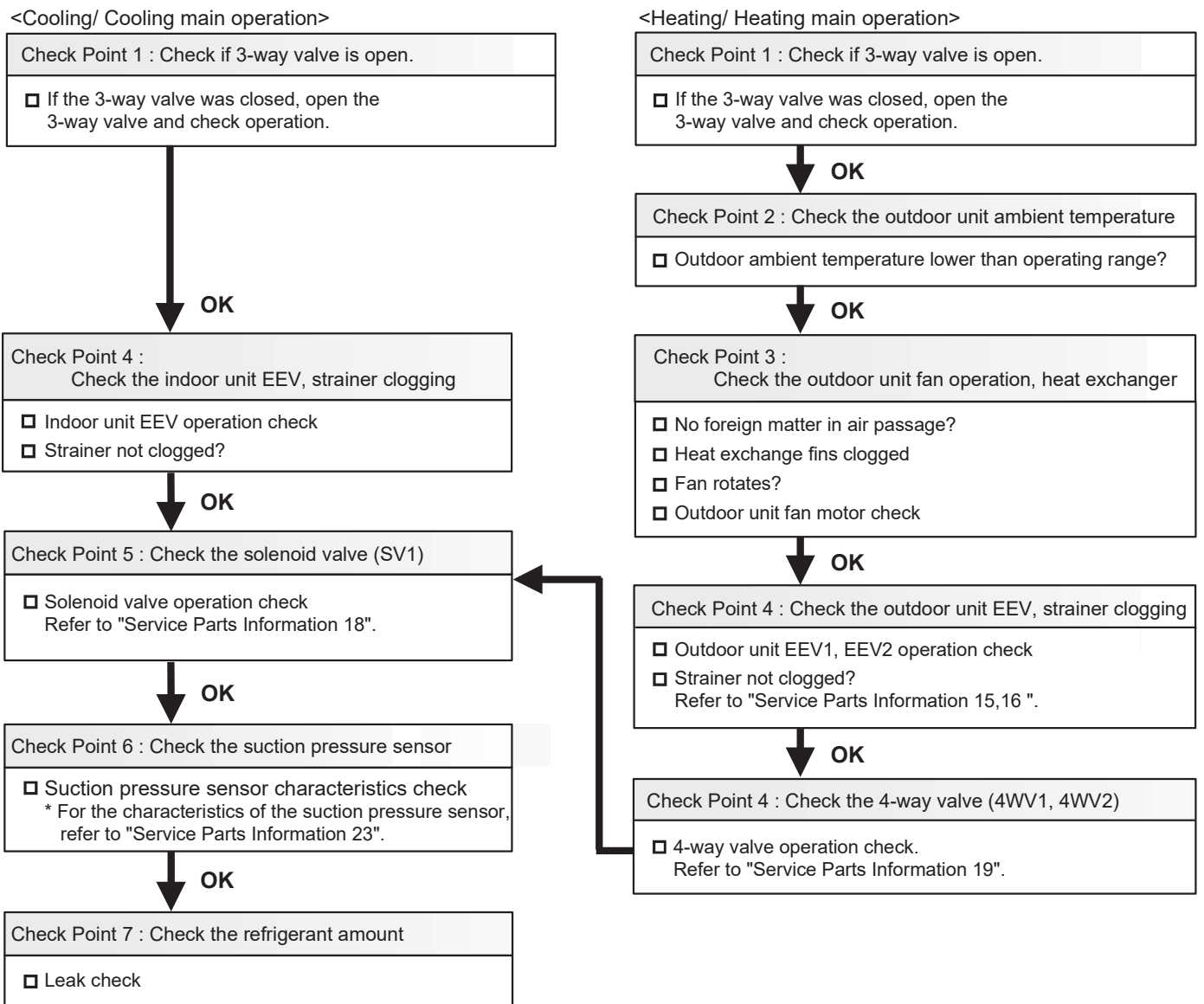

After fixing the problem and for canceling the Error, Error Reset (F3-40) will be required after power reset

Trouble shooting 66 EA6. 3 OUTDOOR UNIT Error Method: Heat Ex.1 gas temp. Error	Indicate or Display: Outdoor Unit : E. A 6. 3 Indoor Unit : Operation LED 9 times Flash, Timer LED 15 Times Flash, Filter LED Continuous Flash. Error Code : 9 U / A 6

Detective Actuators: Heat Ex.1 gas temp. sensor (TH7)	Detective details: <ul style="list-style-type: none"> Heat Ex.1 gas temp. sensor (TH7) for use as condenser (4way valve1:Off, EEV1:Open) is detected abnormally-low to High pressure saturated temp. for 4 minutes or more.
---	--

Forecast of Cause :	<ol style="list-style-type: none"> Heat Ex.1 gas temp. sensor (TH7) not installed correct position. Heat Ex.1 gas temp. sensor (TH7) defective 4-way valve1 (including a coil) defective EEV1 (including a coil) defective Main PCB defective
----------------------------	--

Check Point 1 : Check the condition of Heat Ex.1 gas temp. sensor (TH7)
<input type="checkbox"/> Check the condition of mounting of Heat Ex.1 gas temp. sensor (TH7).



Check Point 2 : Check the Heat Ex.1 gas temp. sensor (TH7)
<input type="checkbox"/> Check characteristics check. (Disconnect the Heat Ex.1 gas temp. sensor from PCB and check.) * For the sensor characteristics, refer to the "Service Parts Information 25".



Check Point 3 : Check the condition of 4-way valve1 coil
<input type="checkbox"/> Check the condition of mounting of 4-way valve1 coil and 4-way valve2 coil.



Check Point 4 : Check the EEV
<input type="checkbox"/> Check the condition of mounting of EEV1 coil. <input type="checkbox"/> Check the connector connection state of EEV1, EEV2, EEV3 coil.



Check Point 5 : Replace Main PCB
<input type="checkbox"/> Check the appearance and condition of mounting of Main PCB. >> If it is abnormal, replace Main PCB. (When Main PCB is replaced, set up the original setting by Rotary, Dip, and Push SW.)



Check Point 6 : Replace 4-way valve1
<input type="checkbox"/> 1. Fully close the 3-way valve, and the refrigerant is recovered.2. 4-way valve1 is replaced. 3. Perform vacuuming of repaired outdoor unit thoroughly , and add the refrigerant with the recovered amount. 4. Check if the error reoccurs on a test run.

After fixing the problem and for canceling the Error, Error Reset (F3-40) will be required after power reset

Caution
 By changing of DIP SW 4-2 to ON, the Back-up operation can start when the active outdoor unit exists on the multi outdoor unit connection. (Stand alone outdoor unit is impossible)
 The following conditions will be concerned in use of back-up operation. (Please do not use the system with back-up operation for long time.)

- The operating compressor life time becomes shorter.
- The operating performance may drop due to the limited active compressor(s).
- The compressor may stop frequently by protection controlling.

*In order to keep the operating capacity, the release of the Low noise mode setting might be necessary.

Trouble shooting 67 EA6. 4 OUTDOOR UNIT Error Method: Heat Ex.2 gas temp. Error	Indicate or Display: Outdoor Unit : E. A 6. 4 Indoor Unit : Operation LED 9 times Flash, Timer LED 15 Times Flash, Filter LED Continuous Flash. Error Code : 9 U / A 6

Detective Actuators: Heat Ex.2 gas temp. sensor (TH8)	Detective details: <ul style="list-style-type: none"> Heat Ex.2 gas temp. sensor (TH8) for use as condenser (4way valve2:Off, EEV2:Open) is detected abnormally-low to High pressure saturated temp. for 4 minutes or more.
---	--

Forecast of Cause :	1. Heat Ex.2 gas temp. sensor (TH8) not installed correct position 2. Heat Ex.2 gas temp. sensor (TH8) defective 3. 4-way valve2 (including a coil) defective 4. EEV2 (including a coil) defective 5. Main PCB defective
----------------------------	--

Check Point 1 : Check the condition of Heat Ex.2 gas temp. sensor (TH8)

Check the condition of mounting of Heat Ex.2 gas temp. sensor (TH8).



Check Point 2 : Check the Heat Ex.2 gas temp. sensor (TH8)

Check characteristics check. (Disconnect the Heat Ex.2 gas temp. sensor from PCB and check.)
* For the sensor characteristics, refer to the "Service Parts Information 25".



Check Point 3 : Check the condition of 4-way valve2 coil

Check the condition of mounting of 4-way valve1 coil and 4-way valve2 coil.



Check Point 4 : Check the EEV2

Check the condition of mounting of EEV2 coil.
 Check the connector connection state of EEV1, EEV2, EEV3 coil.



Check Point 5 : Replace Main PCB

Check the appearance and condition of mounting of Main PCB.
>> If it is abnormal, replace Main PCB.
(When Main PCB is replaced, set up the original setting by Rotary, Dip, and Push SW.)



Check Point 6 : Replace 4-way valve2

1. Fully close the 3-way valve, and the refrigerant is recovered.2. 4-way valve2 is replaced.
3. Perform vacuuming of repaired outdoor unit thoroughly , and add the refrigerant with the recovered amount.
4. Check if the error reoccurs on a test run.

After fixing the problem and for canceling the Error, Error Reset (F3-40) will be required after power reset

Caution
By changing of DIP SW 4-2 to ON, the Back-up operation can start when the active outdoor unit exists on the multi outdoor unit connection. (Stand alone outdoor unit is impossible)
The following conditions will be concerned in use of back-up operation. (Please do not use the system with back-up operation for long time.)

- The operating compressor life time becomes shorter.
- The operating performance may drop due to the limited active compressor(s).
- The compressor may stop frequently by protection controlling.

*In order to keep the operating capacity, the release of the Low noise mode setting might be necessary.

Trouble shooting 68 EAC. 4 OUTDOOR UNIT Error Method: Outdoor unit Heat Sink Temperature Abnormal	Indicate or Display: Outdoor Unit : E. A C. 4 Indoor Unit : Operation LED 9 times Flash, Timer LED 15 Times Flash, Filter LED Continuous Flash. Error Code : 9 U / A C
---	---

Detective Actuators: Heat sink temp. sensor	Detective details: <ul style="list-style-type: none"> ▪ "Protection stop by "heat sink temp. $\geq 91^{\circ}\text{C}(195.8^{\circ}\text{F})$ " occurred 3 times within 60 minutes.
---	---

Forecast of Cause :	1. Foreign matter on heat sink, heat sink dirty 2. Foreign matter on heat exchanger, excessive ambient temperature rise 3. Heat sink temp. sensor defective
----------------------------	---

Check Point 1 : Check the heat sink state
<input type="checkbox"/> Heat sink foreign matter, soiling check



Check Point 2 : Check the foreign matter and ambient temperature of heat exchanger
<input type="checkbox"/> Heat exchange foreign matter check <input type="checkbox"/> Ambient temperature not raised by effect of other heat sources? <input type="checkbox"/> Discharged air not sucked in?



Check Point 3 : Check the heat sink temp. sensor
<input type="checkbox"/> Heat sink temp. sensor characteristics check (Check by disconnecting sensor from PCB.) * For the characteristics of the thermistor, refer to "Service Parts Information 25".

Caution By changing of DIP SW 4-2 to ON, the Back-up operation can start when the active outdoor unit exists on the multi outdoor unit connection. (Stand alone outdoor unit is impossible) The following conditions will be concerned in use of back-up operation. (Please do not use the system with back-up operation for long time.) - The operating compressor life time becomes shorter. - The operating performance may drop due to the limited active compressor(s). - The compressor may stop frequently by protection controlling. *In order to keep the operating capacity, the release of the Low noise mode setting might be necessary.
--

Trouble shooting 69 RB UNIT Error Method: _____ RB Unit EEPROM Access Abnormal	EJ1. 1	Indicate or Display: Outdoor Unit : E. 5 U.1 Indoor Unit : Operation LED 14 times Flash, Timer LED 1 Times Flash, Filter LED Continuous Flash. Error Code : J 1 RB Unit : Power LED ON, Error LED Continuous Flash
---	---------------	--

Detective Actuators: RB Unit Controller PCB	Detective details: When the EEPROM Lead Test failed 3 times at the testing process
---	--

Forecast of Cause : 1. Outside cause 2. Defective connection of electric component 3. Controller PCB defective

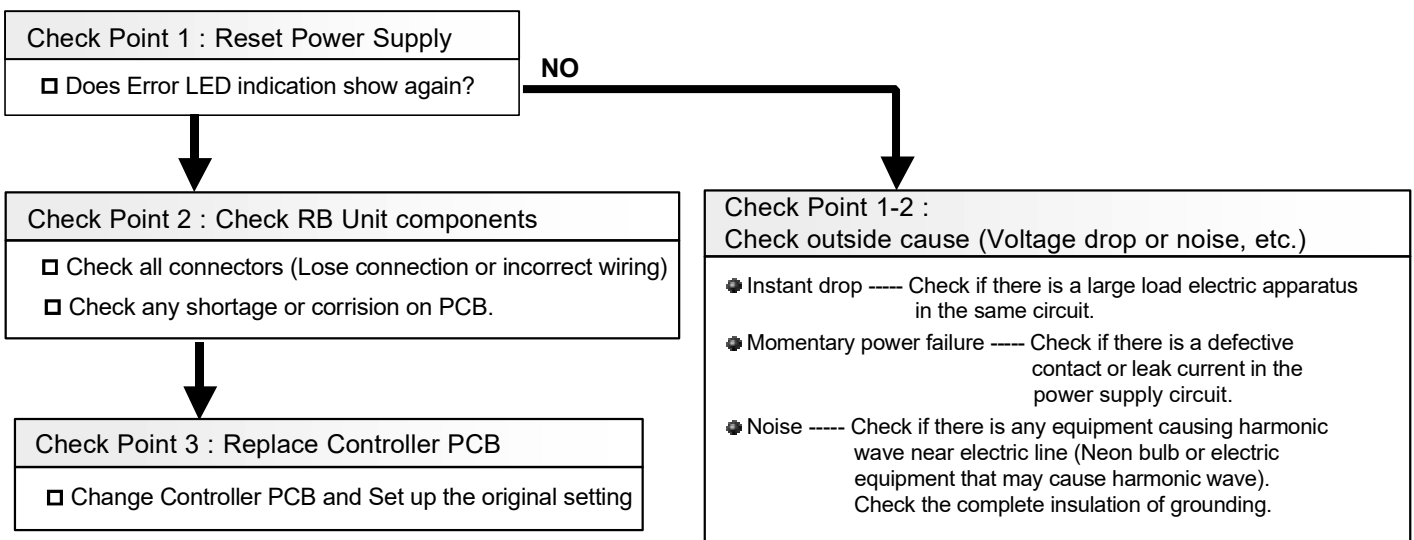

Trouble shooting 70 RB UNIT Error Method: _____ RB Unit transmission PCB2 parallel communication Error	EJ1. 4 Indicate or Display: Outdoor Unit : E. 1 4.1 / 1 4.2* Indoor Unit : 1st: Operation LED 13 times Flash, Timer LED 1 Times Flash, Filter LED Continuous Flash. 2nd: Operation LED 1 time Flash, Timer LED 4 Times Flash Error Code : J 1 / 1 4 RB Unit : Power LED ON, Error LED Continuous Flash
---	---

* Outdoor unit indicates 1 4.1 or 1 4.2 (No communication from Indoor unit)
Service tool indicates Error 1 4.3 or J 1.1, when the service tool detects No communication of outdoor unit or the communication Error of RB unit.

Detective Actuators: RB Unit Controller PCB Circuit RB Unit Communication PCB	Detective details: When Parallel Communication Error (Communication reset occurs continuously more than specified times) is detected.
--	---

Forecast of Cause : 1. Connection failure 2. Outside cause 3. Communication PCB failure 4. Controller PCB defective

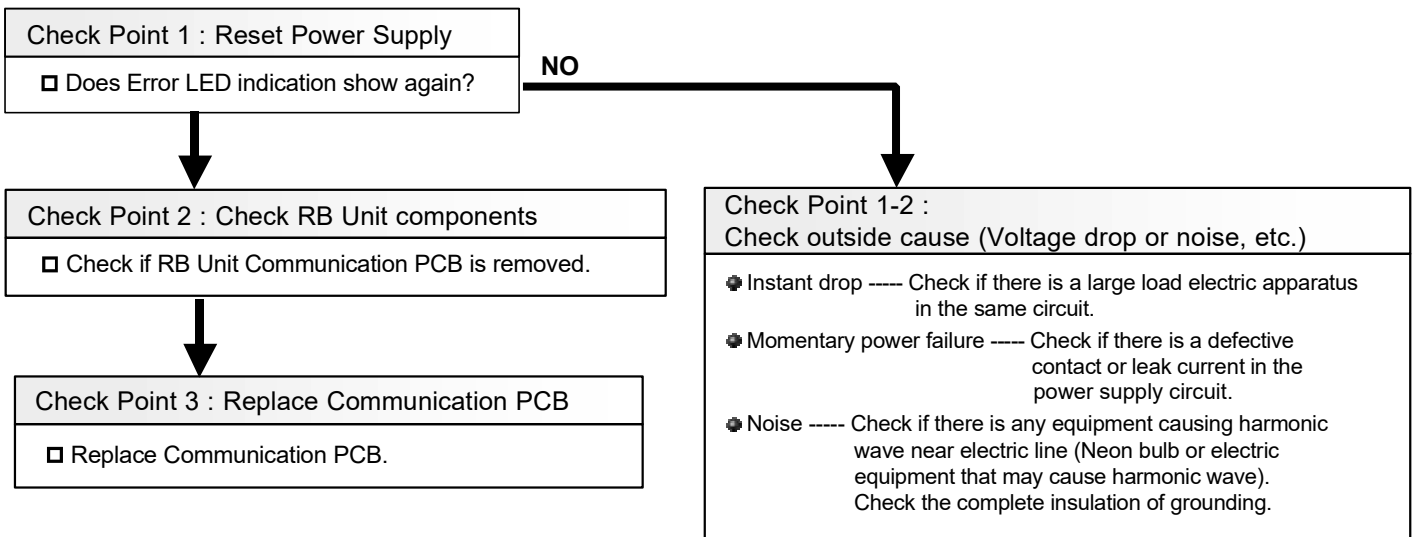

Trouble shooting 71 OUTDOOR UNIT Error Method: Initial Setting Error	Indicate or Display: Outdoor Unit : - - - - Indoor Unit : No Display Error Code : No Display * Service tool does not indicate the Error code
---	---

Detective Actuators: Outdoor unit main PCB	Detective details: • [REDACTED] • [REDACTED] [REDACTED] [REDACTED] [REDACTED] [REDACTED] [REDACTED] [REDACTED] [REDACTED] [REDACTED]
--	---

Forecast of Cause :

1. Power supply defective
2. Outdoor unit address/number of connected slave units setting mistake
3. The number setting mistake of outdoor unit
4. Connection of communication line between outdoor units defective
5. Noise
6. Main PCB defective
7. Inverter PCB defective
8. Transmission PCB defective

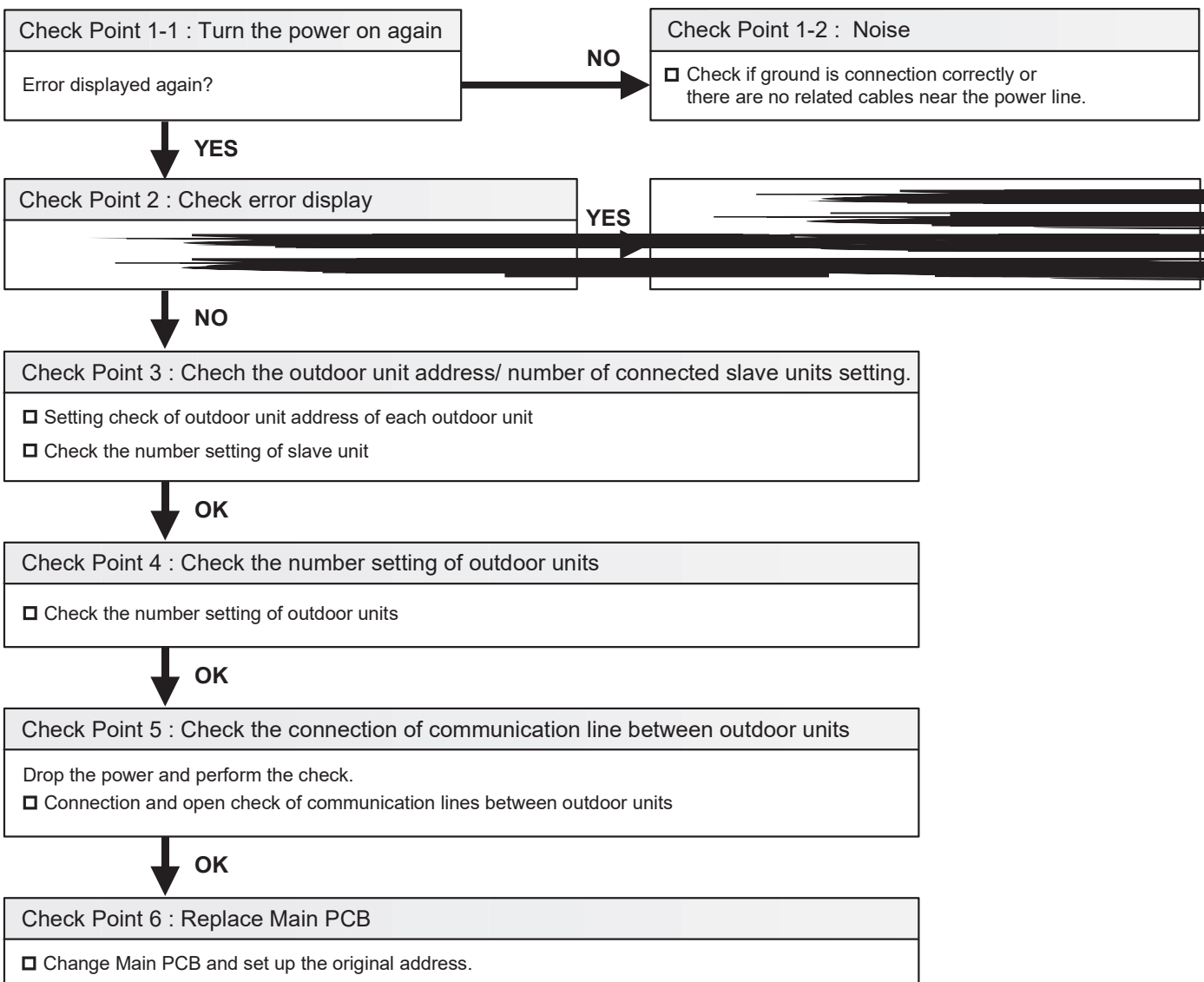

4-2-10 TROUBLE SHOOTING NO ERROR CODE

Trouble shooting 72

**Indoor Unit - No Power
(Except wall mounted type)**

Forecast of Cause :

1. Power Supply failure 2. Outside cause 3. Electrical Component defective

Check Point 1 : Power supply

- Is not the breaker down?
- Instant drop ----- Check if there is a large load electric apparatus in the same circuit.
- Momentary power failure ----- Check if there is a defective contact or leak current in the power supply circuit.
- Noise ----- Check if there is any equipment causing harmonic wave near electric line (Neon bulb or electric equipment that may cause harmonic wave).
Check the complete insulation of grounding.

OK

Check Point 2 : Fuse of Indoor unit

- Is not open circuit ?
If the fuse was open state, check the cause of short circuit on the AC circuit before replacing the spare parts.

NG (Short circuit on AC circuit)

Check Point 3 : Short circuit check on AC circuit

- Check on short circuit state step by step
1. Disconnect AC input wire on the terminal board.
 2. Disconnect Drain pump AC input connector
 3. Disconnect FAN motor AC input connector

NG (Short circuit on AC circuit)

Replace power supply PCB

Check Point 4 : Resistor R101

- Check Resistor R101, Open / Short circuit check

NG (Open circuit on R101)

OK (Not Open)
3.3 Ohm ± 5%

Check Point 5 : Short circuit check on DC supply circuit

- Disconnect CN102 and check short circuit step by step.
1. Check short circuit between the pin No. 1 and the pin No.6
 2. Check short circuit between the pin No. 2 and the pin No.6

NG (Short circuit)

OK (Open circuit)

Check Point 6 : Short circuit check on DC13.5V circuit

- Disconnect CN 4 (DC power supply) , and check short circuit between the pin No. 1 and the pin No.6 step by step
1. Disconnect EEV connector
 2. Disconnect SP motor
 3. Disconnect Wired Remote Controller
 4. Disconnect Transmission PCB

OK (Open circuit)

NG (Short circuit)

ReplaceMain PCB

Check Point 7 : Short circuit check on DC5.0V circuit

- Disconnect CN 4 (DC power supply) , and check short circuit between the pin No. 2 and the pin No.6 step by step
1. Disconnect Indicatopr PCB
 2. Disconnect SW PCB
 3. Disconnect Transmission PCB

NG (Short circuit)

Trouble shooting 73

Indoor Unit - No Power (Wall mounted type)

Forecast of Cause :

1. Power Supply failure
2. Outside cause
3. Electrical Component defective

Check Point 1 : Power supply

- Is not the breaker down?
- Instant drop ----- Check if there is a large load electric apparatus in the same circuit.
- Momentary power failure ----- Check if there is a defective contact or leak current in the power supply circuit.
- Noise ----- Check if there is any equipment causing harmonic wave near electric line (Neon bulb or electric equipment that may cause harmonic wave).
Check the complete insulation of grounding.

OK

Check Point 2 : Fuse or Thermal fuse of Indoor unit

- Is not open circuit ?
If the fuse was open state, check the cause of short circuit on the AC circuit before replacing the spare parts.

NG (Short circuit on AC circuit)

Check Point 3 : Short circuit check on AC circuit

- Disconnect AC power input wires and check short circuit

NG (Short circuit on AC circuit)

OK

Check Point 4 : Power supply circuit of FAN Motor

- Disconnect FAN motor and Check short circuit

NG (Short circuit)

Check Point 5 : Resistor R101

- Check Resistor R101, Open / Short circuit check

NG (Open circuit on R101)

OK (Not Open)
2.2 Ohm \pm 5%

ReplaceMain PCB

NG (Short circuit)

Check Point 6 : Short circuit check on DC13.5V circuit

- Check short circuit between Pin No.1 and Pin No. 6 of CNB01 (DC 13.5V circuit)
1. Disconnect EEV connector
 2. Disconnect SP motor
 3. Disconnect Wired Remote Controller
 4. Disconnect Transmission PCB

OK (Open circuit)

Check Point 7 : Short circuit check on DC5.0V circuit

- Check short circuit between Pin No.5 and Pin No. 7 of CN3 (TEST) (DC 5.0V circuit)
OR
Pin No.1 and Pin No.7 of CN18
1. Disconnect Indicator PCB
 2. Disconnect SW PCB
 3. Disconnect Transmission PCB

NG (Short circuit)

Trouble shooting 74

Outdoor Unit - No Power

Forecast of Cause :

1. Power Supply failure
2. Outside cause
3. Electrical Components defective

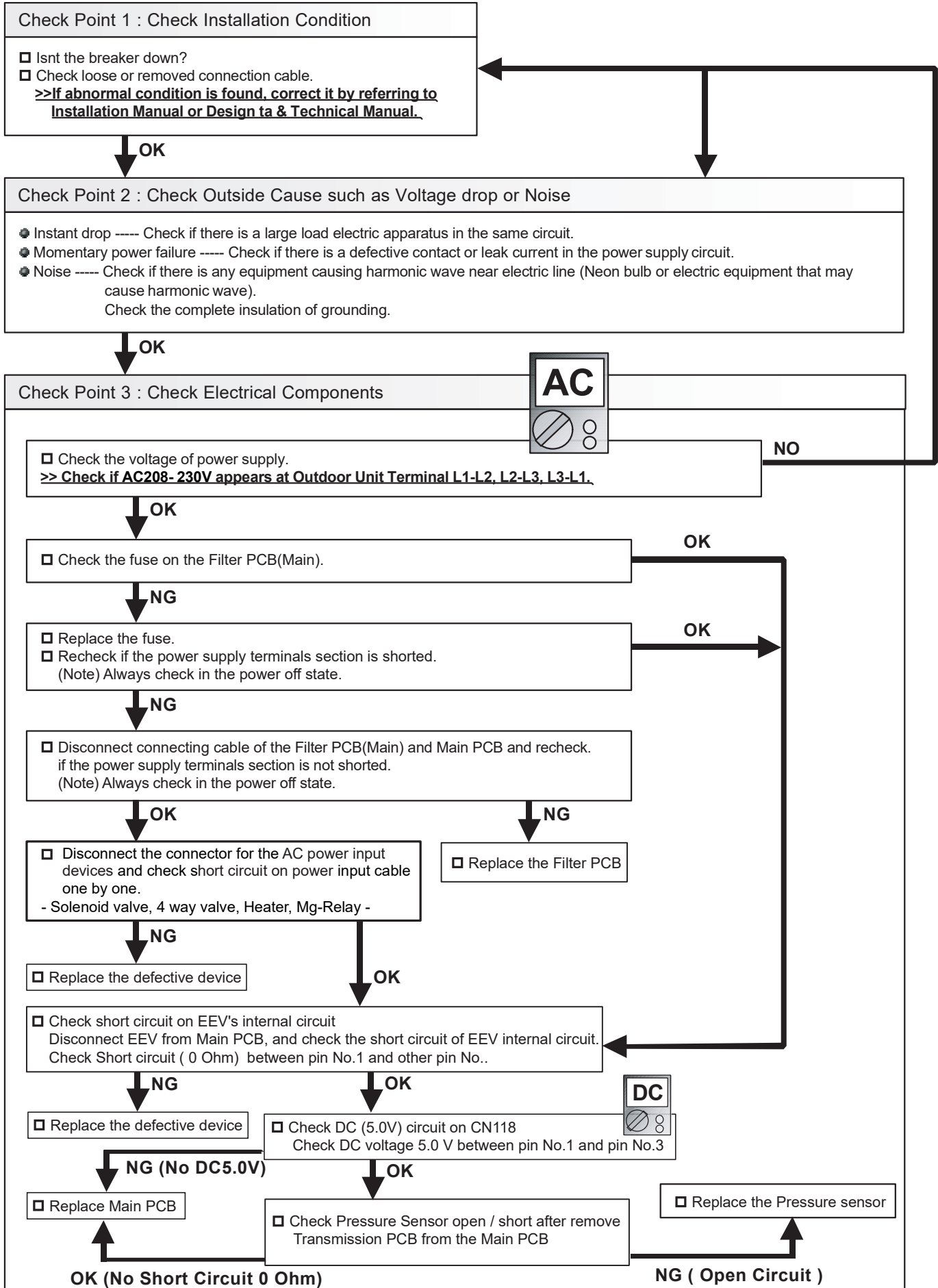

Trouble shooting 75

RB Unit - No Power

Forecast of Cause :

1. Power Supply failure 2. Outside cause 3. Electrical Component defective

Check Point 1 : Power supply

- Is not the breaker down?
- Instant drop ----- Check if there is a large load electric apparatus in the same circuit.
- Momentary power failure ----- Check if there is a defective contact or leak current in the power supply circuit.
- Noise ----- Check if there is any equipment causing harmonic wave near electric line (Neon bulb or electric equipment that may cause harmonic wave).
Check the complete insulation of grounding.

OK

Check Point 2 : Fuse on the PCB

- Is not open circuit ?
If the fuse was open state, check the cause of short circuit on the AC circuit before replacing the spare parts.

OK

NG (Short circuit on AC circuit)

Check Point 3 : Short circuit check on AC circuit

Disconnect AC Power input wires (W101,W102) and Check short circuit

NG (Short circuit on AC circuit)

Replace Main PCB

Check Point 4 : Short circuit on SV coil

- Check Short circuit between Pin No.1 and Pin No.2 of SV coil

NG (Short circuit between Earth)

OK

Replace SV Coil with Connector

Check Point 5-1 : Short circuit check on DC circuit

Check the DC (5.0V) on C1

NG (No voltage)

NG (No Voltage DC 5.0V)

Check Point 5-2 : Short circuit check on DC circuit

Disconnect transmission PCB and check DC 5.0V on C1

Replace Main PCB

OK (DC 5.0V)

Replace Transmission PCB

Trouble shooting 76

No Operation (Power is ON)

Forecast of Cause :

1. Setting/Connection failure
2. Outside cause
3. Electrical Component defective

Check Point 1 : Check indoor, RB Unit and outdoor installation condition

- Indoor Unit - Check incorrect wiring between Indoor Unit- Remote Control, or terminals between Indoor Units.
Or, check if there is an open cable connection.
 - Check address setting (Are all the address of Indoor unit, Outdoor unit and RB unit correct?)
 - Are these Indoor Unit, RB Unit, Outdoor Unit, and Remote Control suitable model numbers to connect?
- >> If there is some abnormal condition, correct it by referring to Installation manual and Design & Technical Manual.**

OK

Turn off Power and check/correct followings.

- Isn't Communication PCB of Indoor Unit removed?
- Is there loose or removed communication line of Indoor Unit and Outdoor Unit?
- Check Terminator (DIP-SW SET 5) is installed on Outdoor Main PCB.
- Check loose or removed communication line between each Outdoor Unit.
- Check loose Communication PCB of each Outdoor Unit.
- Check network cable connection between Indoor unit - Outdoor unit - RB Unit.
- Check loose Communication PCB of each controller PCB inside RB Unit.

OK

Check Point 2 : Check outside cause at Indoor unit, RB Unit, and Outdoor unit (Voltage drop or Noise)

- ⚡ Instant drop -----Check if there is a large load electric apparatus in the same circuit.
- ⚡ Momentary power failure ----- Check if there is a defective contact or leak current in the power supply circuit.
- ⚡ Noise ----- Check if there is any equipment causing harmonic wave near electric line (Neon bulb or electric equipment that may cause harmonic wave).
Check the complete insulation of grounding.

OK

Check Point 3 : Check Electrical Components at Indoor unit, Outdoor unit and RB Unit



- Indoor Unit - Check the voltage between pins 1-3 of the connector (on the control PCB) for connection with the remote controller.
In case of 2 wires WRC, Check the voltage between pins 1-2.

>> If it is DC12V, Remote Control is defective (Controller PCB is normal) >> Replace Remote Control
>> If it is DC 0V, Controller PCB is defective (Check Remote Control once again) >> Replace Controller PCB

- If some of Indoor unit does not operate, replace the Communication PCB of the non-operative Indoor Unit.
>> If the symptom does not change, replace Controller PCB of Indoor Unit.
>> If the symptom does not change, replace Transmission PCB of RB Unit.
>> If the symptom does not change, replace Controller PCB of RB Unit.

- If all of Indoor Units do not operate, check the connection between Main PCB and Communication PCB of Outdoor Unit (Main Unit).
>> If the symptom does not change, replace Communication PCB of Outdoor Unit (Main Unit).
(If it did not work, replace Main PCB.)

Trouble shooting 77

No Cooling / No Heating

Forecast of Cause :

1. Indoor Unit error
2. Outdoor Unit error
3. Effect by Surrounding environment
4. Connection Pipe / Connection Wire failure
5. Refrigeration cycle failure

Check Point 1 : Check Indoor Unit

- Does Indoor Unit FAN run on HIGH FAN?
- Is Air Filter dirty?
- Is Heat Exchanger clogged?

OK

Check Point 2 : Check Outdoor Unit Operation

- Check if Outdoor Unit is operating
- Check any objects that obstruct the air flow route.
- Check clogged Heat Exchanger.
- Is the pipe length setting (Push Switch "MODE/EXIT", "SELECT", "ENTER") suitable?
- Is the Valve open?

OK

Check Point 3 : Check Site Condition

- Is capacity of Indoor Unit fitted to Room size?
- Any windows open? Or direct sunlight ?

OK

Check Point 4 : RB Unit installation Condition

- Check Error LED on RB Unit controller PCB
==> Wrong wire connection of Network cable
(Network cable for O.U. was installed on the terminal for I.U.)
 - Check wire connection between I.U. and applical terminal of RB unit.
==> Cross over connection, Lose connection
 - Check Solenoid valve wrong connection on the PCB
==> Check the color of connector on the controller PCB
 - Check Solenoid valve defective
==> AC Power input and check the operation
 - Check pipe connection
==> Pipe Diameter, pipe length
- >> If there is an abnormal condition, correct it by referring to RB Unit Trouble shooting**

OK

Check Point 5 : Check Indoor/Outdoor Installation Condition

- Check connection pipe (specified pipe length & Pipe diameter?)
 - Check any loose or removed communication line.
- >> If there is an abnormal condition, correct it by referring to Installation Manual or Design & Technical Manual.**

OK

Check Point 6 : Check Refrigeration Cycle

- Check if Strainer is clogged (Refer to the figure at right).
 - Measure Gas Pressure and if there is a leakage, correct it.
- >> When recharging the refrigerant, make sure to perform vacuuming, and recharge the specified amount.**
- ▶ Check EEV (Refer to the Service Parts Information)
 - ▶ Check Solenoid Valve (Refer to the See Service Parts Information)
 - ▶ Check Compressor (Refer to theSee Service Parts Information)
 - ▶ Check 4 way valve (Refer to theSee Service Parts Information)

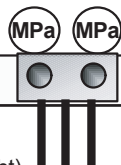

Attention!!

Strainer normally does not have temperature difference between inlet and outlet as shown in (1), but if there is a difference like shown in (2), there is a possibility of inside clogged. In this case, replace Strainer.

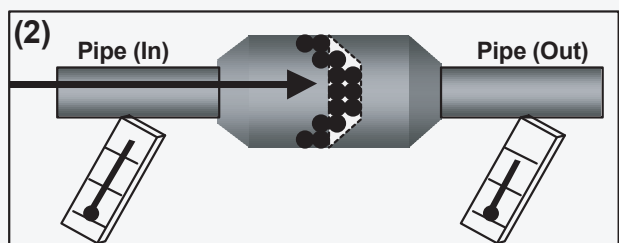
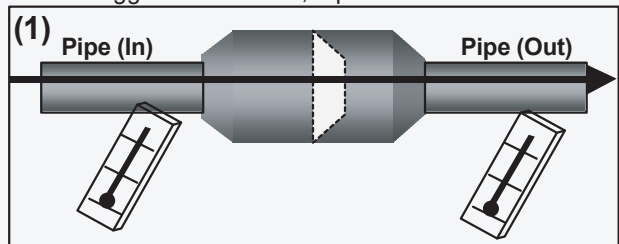

Trouble shooting 78

Abnormal Noise

Forecast of Cause :

1. Abnormal installation (Indoor/Outdoor / RB Unit)
2. Fan failure(Indoor/Outdoor)
3. EEV failure (Indoor)
4. Compressor failure (Outdoor)

Diagnosis method when Abnormal Noise is occurred

Abnormal noise is coming from Indoor Unit
(Check and correct followings)

- Is Main Unit installed in stable condition?
- Is the installation of Air suction grille and front panel normal?
- In case of Duct type : Is Static Pressure range normal?
(Refer to Data & Technical Manual)

OK

- Is Fan broken or deformed?
- Is the screw of Fan loose?
- Is there any object which obstruct the Fan rotation?

Attention!!

If Refrigerant Noise is occurring, Check if the Indoor and Outdoor Thermistor is wrongly installed. Check and correct the thermistor.

Abnormal noise is coming from Outdoor Unit
(Check and correct followings)

- Is Main Unit installed in stable condition?
- Is Bell Mouth installed normally?

OK

- Is Fan broken or deformed?
- Is the screw of Fan loose?
- Is there any object which obstruct the Fan rotation?

OK

- Check if vibration noise by loose bolt or contact noise of piping is happening.

OK

- Is Compressor locked?
>> Check Compressor (Service Parts Information 2,3)

Diagnosis method when Abnormal Noise is occurred

Abnormal noise is coming from RB Unit
(Check and correct followings)

- Is Main Unit installed in stable condition?
- Is the limitation of connectable number of indoor unit and connectable total capacity of indoor unit correct?
- Is Pipe connection correct?
(Wrong pipe connection - Gas pipe, Suction pipe, Liquid pipe -
Check pipe size, Crossover connection between pipe and Network cable)

OK

- Are solenoid valve connectors correct position ?
(Check the color of connectors)
- Are solenoid valves operation correct ?
(Check the coil of SV's, Open / Short, Click sound at ON state)

Trouble shooting 79

Water Leaking

Forecast of Cause :

1. Erroneous installation 2. Drain hose failure 3. Float Switch failure

Diagnosis method when water leak occurs

- Is Main Unit installed in stable condition?
- Is Main Unit broken or deformed at the time of transportation or maintenance?

↓ OK

- Is Drain Hose connection loose?
- Is there a trap in Drain Hose?
- Is Drain Hose clogged?

↓ OK

- Is Fan rotating?
>> Check Fan Motor (Service Parts Information 19)

↓ OK

- Is Float Switch defective?
>> Check Float Switch (Refer to Trouble Shooting)

Diagnosis method when water is spitting out

- Is the filter clogged?

↓ OK

- Check Gas Pressure and correct it if there was a gas leak.

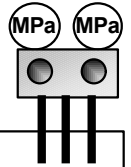

Attention!!

If water is leaking from the Indoor Unit that is not in operation, there is a possibility of Indoor EEV is not closed.

=> Check EEV (Service Parts Information)

Trouble shooting 80

Outdoor air unit - No Power

Forecast of Cause :

1. Power Supply failure
2. Outside cause
3. Electrical Component defective

Check Point 1 : Power supply

- Is not the breaker down?
- Instant drop ----- Check if there is a large load electric apparatus in the same circuit.
- Momentary power failure ----- Check if there is a defective contact or leak current in the power supply circuit.
- Noise ----- Check if there is any equipment causing harmonic wave near electric line (Neon bulb or electric equipment that may cause harmonic wave).
Check the complete insulation of grounding.

OK

OK (No short circuit)

Check Point 2 : Check Protector (20A)

- Check protector open / short
If the protector is open circuit, replace it.

OK (No short circuit)

Check Point 3 : Check AC line

- Check AC line (L-N) open / short

NG (Short circuit)

Check Point 4 : Check short circuit Filter PCB

- Disconnect the wire between Filter PCB and reactor, check short circuit of AC line.
If there is short circuit, replace the Filter PCB.

OK (No short circuit)

Check Point 5 : Check short circuit Diode bridge

- Connect the disconnected wire(s) on the check point 4, disconnect the wire between Diode bridge and Capacitor, check short circuit of AC line.
If there is short circuit, replace the Diode bridge.

OK (No short circuit)

Check Point 6 : Check short circuit Capacitor

- Connect the disconnected wire(s) on the check point 5, disconnect the wire between Capacitor and Filter PCB, check short circuit of AC line.
If there is short circuit, replace the Capacitor.

OK (No short circuit)

Check Point 7 : Check short circuit Power supply PCB

- Connect the disconnected wire(s) on the check point 6, disconnect the wire of Fan motor, check short circuit of AC line.
If there is short circuit, replace the Power supply PCB.

OK (No short circuit)

Check Point 8 : Check Fan Motor

- Check open / short of FAN motor
Refer to the Service Parts Information 21
If there is short circuit, replace FAN motor.

Check Point 9 : Short circuit check on DC circuit

- Disconnect the connector (CN200) on the Power supply PCB and check the short circuit
1. DC12V line (CN200 Pin 1 - 5)
 2. DC 5V Line (CN200 Pin 1 - 3)
 3. DC 15V-1 Line (CN500 Pin 3 - 4)
 4. DC 15V-2 Line (CN530 Pin 3 - 4)
- If one of them is short circuit, replace the Power supply PCB

OK (No short circuit)

Check Point 10 : Check short circuit of actuators (for DC12V)

- Disconnect the CN10 (EEV1) on the Main PCB, and check short circuit on Main PCB CN 4 Pin 1 - 5.
If the short circuit disappears, replace the EEV coil.
- Disconnect the CNC01 (WRC) on the Main PCB, and check short circuit on Main PCB CN 4 Pin 1 - 5.
If the short circuit disappears, check the WRC wire, WRC.
- Disconnect the CNB01 (Ext.Out) on the Main PCB, and check short circuit on Main PCB CN 4 Pin 1 - 5.
If the short circuit disappears, check the Ext. device or wiring.
- Disconnect the CN2 (TransmissionPCB) on the Main PCB, and check short circuit on Main PCB CN 4 Pin 1 - 5.
If the short circuit disappears, replace the Transmission PCB.
- Disconnect the CN22 (Interconnecting wire) on the Main PCB, and check short circuit on Main PCB CN 4 Pin 1 - 5.
If the short circuit disappears, replace the Filter PCB.
- If the short circuit appears after disconnecting actuators, replace the Main PCB.

OK (No short circuit)

Check Point 11 : Check short circuit of actuators (for DC5V)

- Disconnect the CN14 (SW PCB) on the Main PCB, and check short circuit on Main PCB CN 4 Pin 1 - 3.
If the short circuit disappears, replace the SW PCB.
- Disconnect the CN18 (Receiver unit *Option) on the Main PCB, and check short circuit on Main PCB CN 4 Pin 1 - 3.
If the short circuit disappears, check the wire, Receiver unit.
- Disconnect the CN2 (Transmission PCB) on the Main PCB, and check short circuit on Main PCB CN 4 Pin 1 - 3.
If the short circuit disappears, replace the Transmission PCB.
- Disconnect the CN21 (Interconnecting wire) on the Main PCB, and check short circuit on Main PCB CN 4 Pin 1 - 3.
If the short circuit disappears, replace the Power supply PCB.
- If the short circuit appears after disconnecting actuators, replace the Main PCB.

<p>Trouble shooting 81 E39. 1 INDOOR UNIT Error Method: (E39. 2) Indoor Unit power supply error for FAN motor 1 (2)</p>	<p>Indicate or Display: Outdoor Unit : E.5 U.1 Error Code : 3 9 , 3 9 . 1 (2)</p>
--	--

<p>Detective Actuators: Indoor Unit Controller PCB Circuit Indoor Unit Power supply PCB Circuit</p>	<p>Detective details: When the DC power input for Fan motor < W500 - W501 (W530 - W531) on the Power supply PCB > becomes lower voltage than the specified voltage.</p>
--	---

Forecast of Cause : 1. Noise momentary open, voltage drop 2. Wire connection 3. Fan motor
4. Peripheral electric devices 5. Power supply PCB 6. Controller PCB

Check Point 1 : Check if any outside cause such as voltage drop or noise

- Instant voltage drop ---- Check if there is any electric equipment with a large load within the same circuit.
- Momentary power failure ---- Check contact failure or leak current in power supply circuit
- Check if there is any equipment that causes harmonic wave near the power cable (Neon light bulb or any electronic equipment which causes harmonic wave). And check the complete insulation of grounding.

>>If the same symptom does not reappear after resetting the power, possibility of noise is high.

↓
OK

Check Point 2 : Check wire connection

- ❑ Wire lose connection / damage between the CN21 on the Controller PCB and CN250 on the Power supply PCB. In case of Model 72, between W530 (W531) on the Power supply PCB and Capacitor.

>>If there is abnormal on the wire, replace it

↓
OK

Check Point 3 : Check rotation of Fan / wire resistance

- ❑ Rotate the applicable fan by hand when operation is off.
- ❑ Disconnect the connector from the Power supply PCB and Check resistance value of Motor connector. (Refer to the service parts information 21)

↓
OK

Check Point 4 : Check peripheral devices, Posistor, Capacitor, Diode bridge

- ❑ Check resistance value, short circuit, visible damage

>>If there is abnormal , replace it

↓
OK

Check Point 5 : Replace Power supply PCB

- ❑ Change Power supply PCB

↓
NG

Check Point 6 : Replace Controller PCB

- ❑ Change Controller PCB and set up the original address.

Trouble shooting 82 INDOOR UNIT Error Method: Indoor unit suction air temp. thermistor error	E 4A.1	Indicate or Display: Outdoor Unit : E.5 U.1 Error Code : 4 A, 4 A. 1
--	---------------	---

Detective Actuators: Indoor Unit Controller PCB Circuit Suction air temp. thermistor	Detective details: When Indoor unit suction air temp. thermistor open or shortage is detected
---	---

Forecast of Cause : 1. Connector defective connection 2. Thermistor defective 3. Controller PCB defective

Check Point 1 : Check connection of Connector
<input type="checkbox"/> Check if connector is loose or removed <input type="checkbox"/> Check erroneous connection <input type="checkbox"/> Check if thermistor cable is open >>Reset Power when reinstalling due to removed connector or incorrect wiring.



Check Point 2 : Remove connector and check sensor resistance value									
Sensor Characteristics (Rough value)									
Temperature (°F)	32	41	50	59	68	77	86	95	
Temperature (°C)	0	5	10	15	20	25	30	35	
Resistance Value (kΩ)	33.6	25.2	20.1	15.8	12.5	10.0	8.0	6.5	
Temperature (°F)	104	113	122						
Temperature (°C)	40	45	50						
Resistance Value (kΩ)	5.3	4.3	3.5						
► If Thermistor is either open or shorted, replace it and reset the power.									

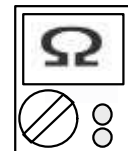

Check Point 3 : Check voltage CN9 of Controller PCB (DC5.0V)
► If the voltage does not appear, replace Controller PCB and set up the original address.



Trouble shooting 83 INDOOR UNIT Error Method: E 4A.2 Indoor unit discharge air temp. thermistor error	Indicate or Display: Outdoor Unit : E.5 U.1 Error Code : 4 A, 4 A. 2
--	---

Detective Actuators: Indoor Unit Controller PCB Circuit Discharge air temp. thermistor	Detective details: When Indoor unit discharge air temp. thermistor open or shortage is detected
---	---

Forecast of Cause : 1. Connector defective connection 2. thermistor defective 3. Controller PCB defective

Check Point 1 : Check connection of Connector
<input type="checkbox"/> Check if connector is loose or removed <input type="checkbox"/> Check erroneous connection <input type="checkbox"/> Check if thermistor cable is open >>Reset Power when reinstalling due to removed connector or incorrect wiring.



Check Point 2 : Remove connector and check sensor resistance value								
Sensor Characteristics (Rough value)								
Temperature (°F)	32	41	50	59	68	77	86	95
Temperature (°C)	0	5	10	15	20	25	30	35
Resistance Value (kΩ)	33.6	25.2	20.1	15.8	12.5	10.0	8.0	6.5
Temperature (°F)	104	113	122					
Temperature (°C)	40	45	50					
Resistance Value (kΩ)	5.3	4.3	3.5					
► If Thermistor is either open or shorted, replace it and reset the power.								

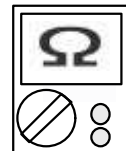

Check Point 3 : Check voltage CN9 of Controller PCB (DC5.0V)
► If the voltage does not appear, replace Controller PCB and set up the original address.



Trouble shooting 84 E59. 2 INDOOR UNIT Error Method: Indoor Unit Fan Motor 2 rotation speed Error	Indicate or Display: Outdoor Unit : E.5 U.1 Error Code : 5 9, 5 9. 2
---	---

Detective Actuators: Indoor Unit Controller PCB Circuit Indoor Fan Motor 2	Detective details: When the FAN motor feed back rotation value which is detecting on the controller PCB becomes 0 and lasts for more than 1 minute at motor operation condition. Or, when the feed back rotation value continues at 1/ 3 of target value for more than 1 minute.
---	---

Forecast of Cause : 1. Fan rotation failure 2. Fan motor winding open 3. Motor protection by ambient temp. increase
4. Capacitor failure 5. Controller PCB failure

Check Point 1 : Check rotation of Fan

Rotate the fan by hand when operation is off.
(Check if fan is caught, dropped off or locked motor)
>>If Fan or Bearing is abnormal, replace it.

↓
OK

Check Point 2 : Check Motor winding / Internal PCB circuit

Check Indoor Fan motor (Refer to the PARTS INFORMATION 21)
>>If Fan motor is abnormal, replace it.

↓
OK

Check Point 3 : Check ambient temp. around motor

Check excessively high temperature around the motor.
(If there is any surrounding equipment that causes heat)
>>Upon the temperature coming down, restart operation..

↓
OK

Check Point 4 : Check Motor Capacitor

Check continuity of motor capacitor
>>If it is shorted, replace the capacitor.



↓
OK

Check Point 5 : Replace Controller PCB

Change Controller PCB and set up the original address.

4-3 SERVICE INFORMATION

SERVICE INFORMATION

Network communication Abnormal

- Basic trouble shooting procedure -

1. Check Error code in one network segment separately, and check the Error code of (OU, IU, RB Error LED, RC, ST)
< If the system has more than 2 Network segments, disconnect the other Network segment.>
2. Connect Service tool to the Outdoor unit, and try out **"Address checker"** Function by the Service toll.
< Check missing indoor unit or RB unit or outdoor unit by using Address checker function of Service tool>
3. Check terminal resistance value $53 \text{ Ohm} \pm 5\%$ + Line Resistance on the terminal board one by one.
< Terminal Resistance is located on the Outdoor unit PCB(activated SET 5-4 ON), and the Main PCB of RB Unit each >
*Refer to the wiring diagram of Network cable

Example

Terminal Resistance (A) is located on the controller PCB of Outdoor unit as the Network for RB unit, Cooling only Indoor unit
Terminal Resistance (B) is located on the Main PCB of RB unit as the Network for Indoor unit 1
Terminal Resistance (C) is located on the Main PCB of RB unit as the Network for Indoor unit 2
Terminal Resistance (D) is located on the Main PCB of RB unit as the Network for Indoor unit 3 and Indoor unit 4

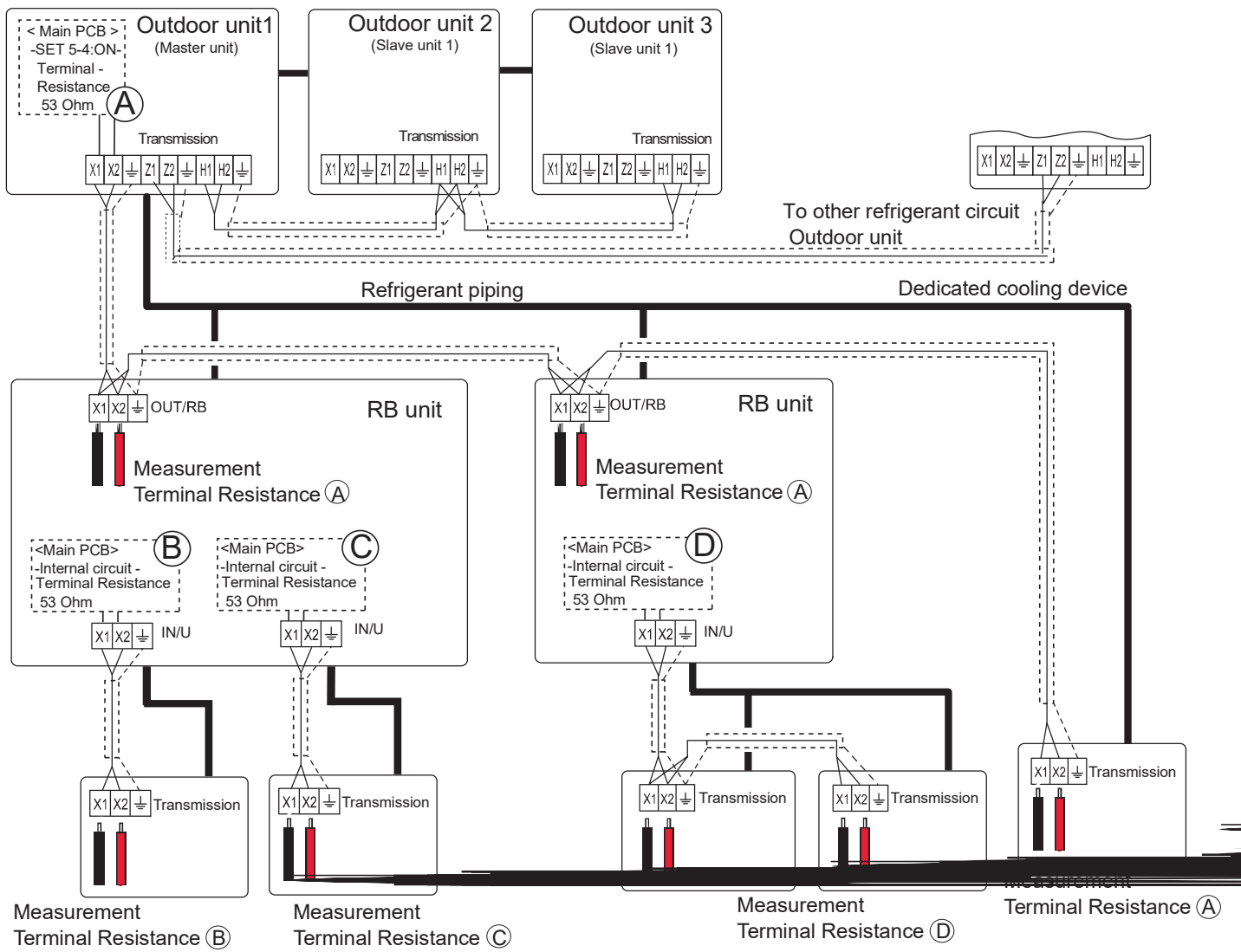

SERVICE INFORMATION

RB Unit Abnormal (No Cooling, No Heating, Abnormal Noise)

- Check functioning of Solenoid Valve * Valve or Pipe Blockage , Opposite operation of Valves can be the cause of Noise problem.
- Check Solenoid coil position / connection
- Check pipe temperature difference during operation

Solenoid valve Controlling

SV No. (Indication on Service Tool)	Function	Cooling / Dry mode	Heating mode	Fan mode / Stop
SV1 (SVD1)	Discharge Valve	Close	Open	Close
SV4 - 6 (SVS)	Suction Valve	Open	Close	Close
SV2 (SVB2)	Equalization Valve (Pressurization)	Close	Open	Close
SV3 (SVB1)	Equalization Valve (Decompression)	Open	Close	Open

Position of Solenoid coil

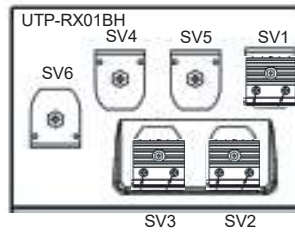
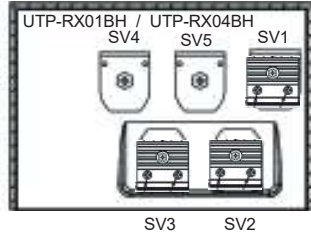
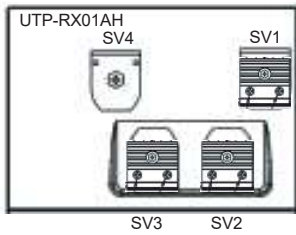

Color of Connector

SV1	Green
SV2	Blue
SV3	Black
SV4	White
SV5	Red
SV6	Yellow

Solenoid Coil resistance

<Refer to the Parts information 26>

CAUTION: The solenoid coil which has a heat sink is hot.

When you approach the solenoid coil, turn off the power supply for the RB unit and wait until the temperature of coil becomes low.

Pipe temperature in Cooling mode

Normal Operation

	Low Pressure Pipe	Indoor unit Gas Pipe
Pipe Temp.	COLD	COLD

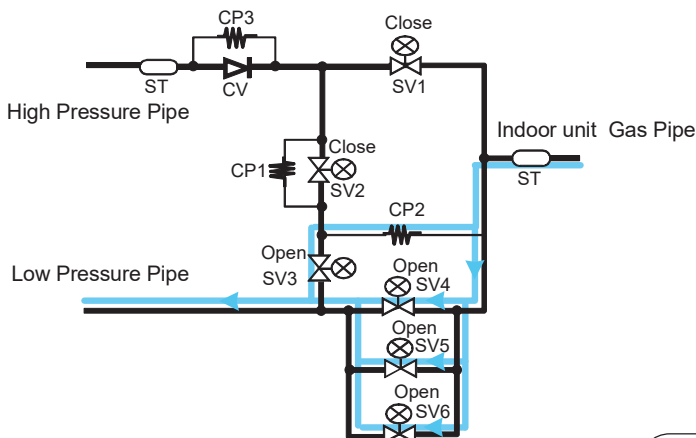

Possible Cause

	Low Pressure Pipe	Indoor unit Gas Pipe
Pipe Temp.	COLD	Less COLD

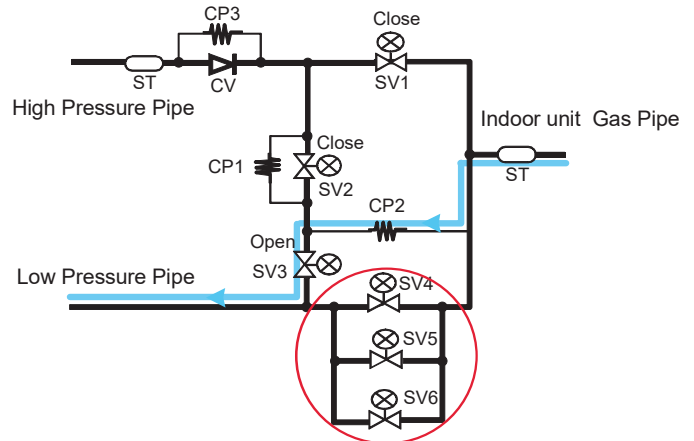

When SV4, SV5 SV6 internal blockage or Close position, the refrigerant flow will be lessened, Indoor unit Gas pipe Temp. > Low pressure pipe temp

Pipe temperature in Heating mode

Normal Operation

	High Pressure Pipe	Indoor unit Gas Pipe
Pipe Temp.	HOT	HOT

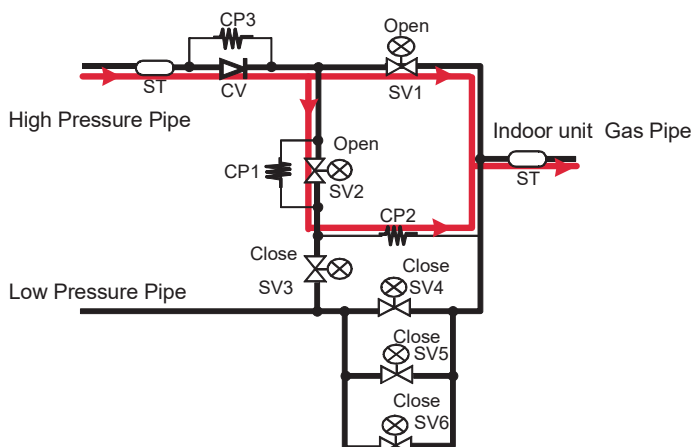

Possible Cause

	High Pressure Pipe	Indoor unit Gas Pipe
Pipe Temp.	HOT	Less HOT

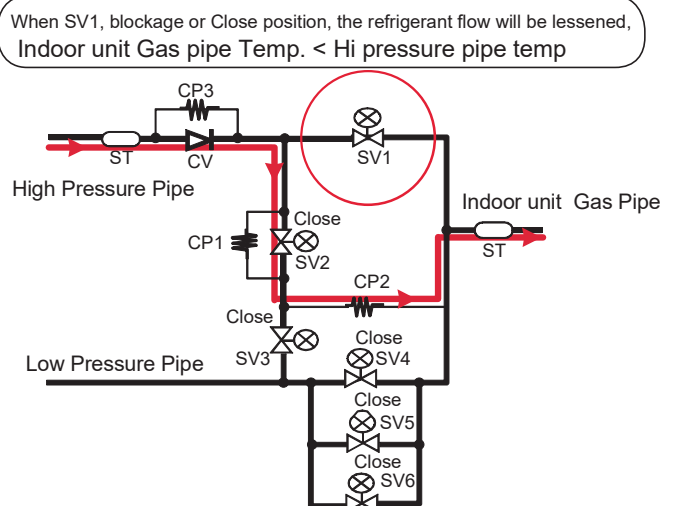

When SV1, blockage or Close position, the refrigerant flow will be lessened, Indoor unit Gas pipe Temp. < Hi pressure pipe temp

4-4 SERVICE INFORMATION

SERVICE INFORMATION

Backup Operation

Details :

- Backup operation is the operating method of replacing compressor while the system is running. Compressor can be replaced without stopping the system.
- In backup operation, cooling and heating capacity is decreased by the capacity of the separated outdoor unit.
- The work procedure is as follows.

4-4-1 Backup operation

1. Method of backup operation

1-1. Backup operation when compressor of the master unit is defective.

[Procedure]

(Example: Three outdoor units are connected.)

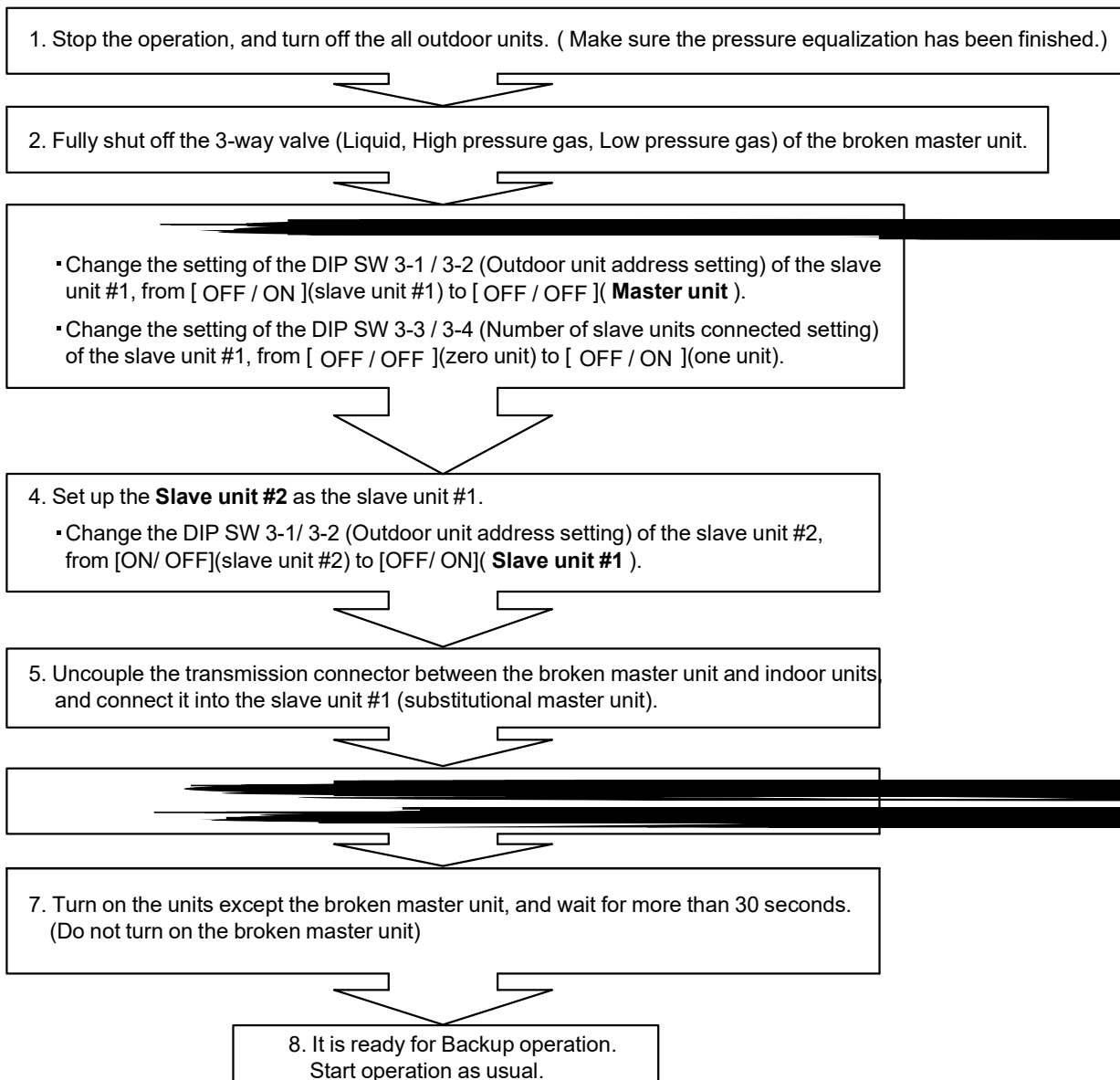

1-2. Backup operation when compressor of the slave unit #1 is broken.

[Procedure]

(Example: Three outdoor units are connected. the slave unit #1 is broken.)

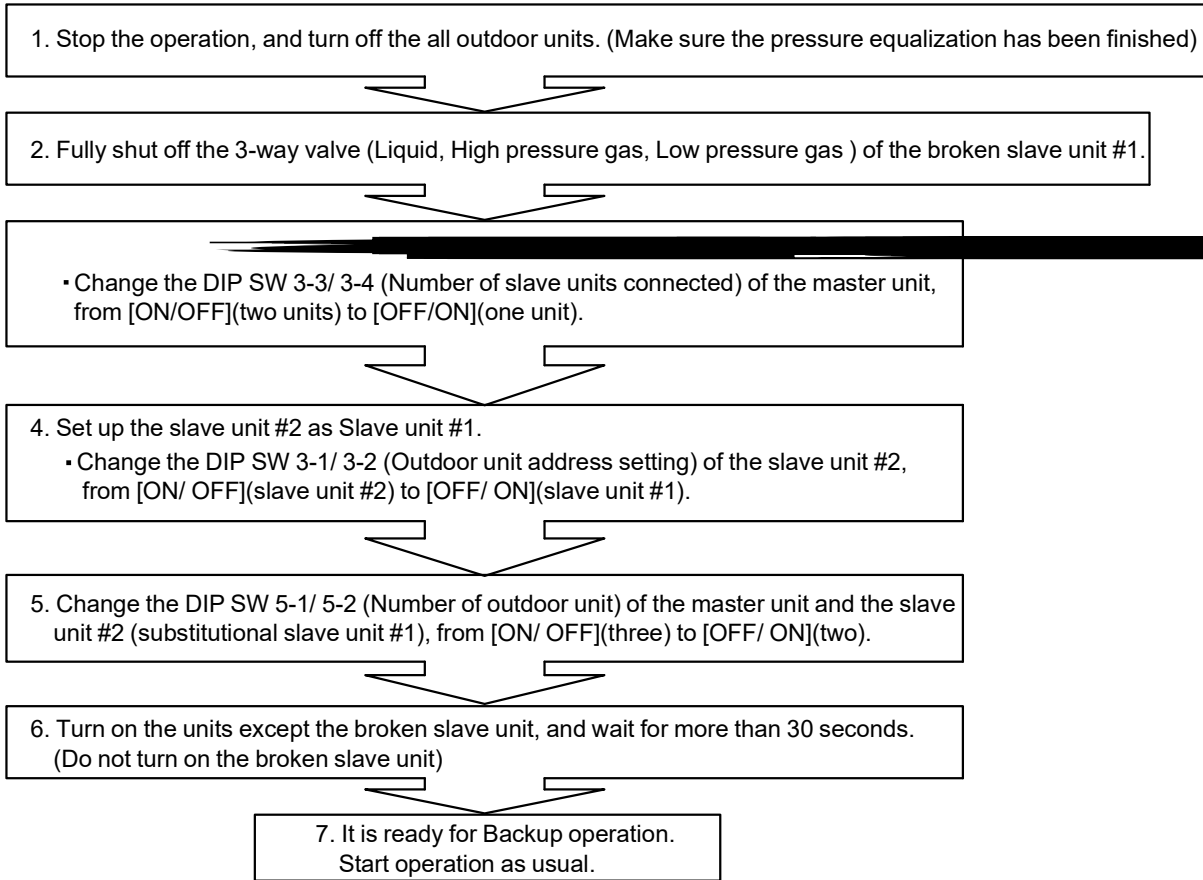

4-4-2 Work procedure after the backup operation

1. Refrigerant shortage at the backup operation

When excessive refrigerant accumulates in the defective outdoor unit during the backup operation, it becomes capacity shortage by refrigerant shortage.

The meaning of the sign

- LPS : Low pressure sensor detection value
- EEV1 : Expansion valve #1
- EEV2 : Expansion valve #2
- TH2 : Outdoor temperature sensor detection value
- TH3 : Suction temperature sensor detection value
- TH7 : Heat -Ex.1 gas temparture sensor detection value
- TH8 : Heat -Ex.2 gas temparture sensor detection value
- TH9 : Heat -Ex.1 liquid temparture sensor detection value
- TH10 : Heat -Ex.2 liquid temparture sensor detection value

<How to judge, when refrigerant is deficient>

Refrigerant shortage is judged by the information from "Service tool" during backup operation. The outdoor unit shall enter the Cooling Main mode or Heating Main mode.

1. On Cooling operation

- ① It often creates "Low pressure protection stop".
>>> When LPS < 14.5psi(0.1MPa) for 10 minutes or When LPS < 7.25psi(0.05Mpa)
If one of this condition happens 5 times within 180 minutes, the system stops permanently.
- ② Running indoor unit's EEV is fully open condition.
>>> It displays corresponding indoor unit's EEV on the chart at the bottom of the monitor.
If there is no sign of closing the EEV from fully opened condition.

2. On Heating operation

- ① It often creates "Low pressure protection stop".
>>> When LPS < 14.5psi(0.1MPa) for 10 minutes or When LPS < 7.25psi(0.05Mpa)
If one of this condition happens 5 times within 180 minutes, the system stops permanently.
- ② EEV1 opens at 480 pulse. (fully open)
EEV2 opens at 480 pulse. (fully open)
- ③ Suction superheat is too high, when the condition is following
TH9 < Th7, TH10 < TH8, TH2 ≧ TH3
Note: The suctin SH can be larger temprary at the start up, oil recovery, defrosting.
Even if the lowpressure protection does not occur, keep watching the operating condition for a while.

<How to respond, when refrigerant is deficient>

- ① Reuse the refrigerant of the broken master unit.

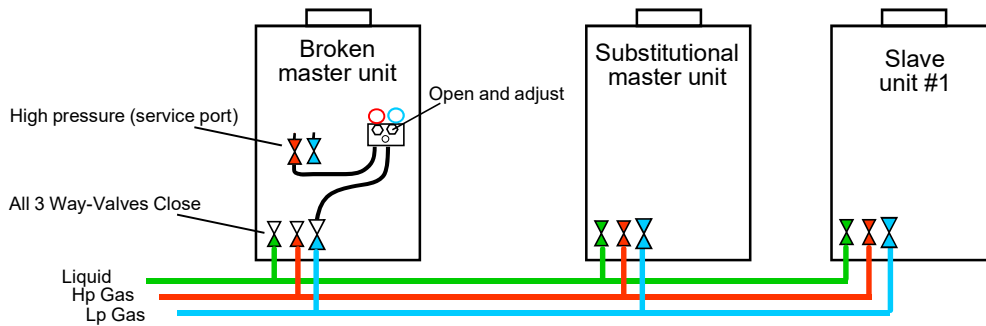

Connect the high pressure service port of the broken master unit and the low pressure pipe of the broken master unit by pressure gauge.

>>> Refrigerant release from the heat exchanger of the broken master unit.
(Refrigerant is removed until refrigerant shortage is resolved)

When new refrigerant is added to the operating system, check the weight of additional refrigerant, and adjust the total refrigerant amount after repairing.

- ② Recover the remaining refrigerant in the broken master unit from the service port(s).

2. Refrigerant charging after the compressor replacement.

- ① If the amount of recovered refrigerant is available that was pulled out of outdoor unit which compressor was replaced.
(When the refrigerant is recovered by refrigerant recovery machine, and its weight is measured.)
>>> Perform vacuuming of repaired outdoor unit thoroughly, and add the refrigerant with the recovered amount.
- ② If the amount of recovered refrigerant from outdoor unit that compressor was replaced is not sure.
(When the refrigerant leakage was the case.)
>>> Once recover all units' refrigerant, and recharge the calculated amount of refrigerant (Original amount and additional amount) again after vacuuming.

Note: To use the recovered refrigerant is not recommended in case of refrigerant leakage.
Always charge fresh refrigerant with correct amount for the system after repairing.

4-5 SERVICE PARTS INFORMATION

SERVICE PARTS INFORMATION 1

Compressor

Diagnosis method of Compressor (If Outdoor Unit 7 segment LED displays Error, refer to Trouble shooting)

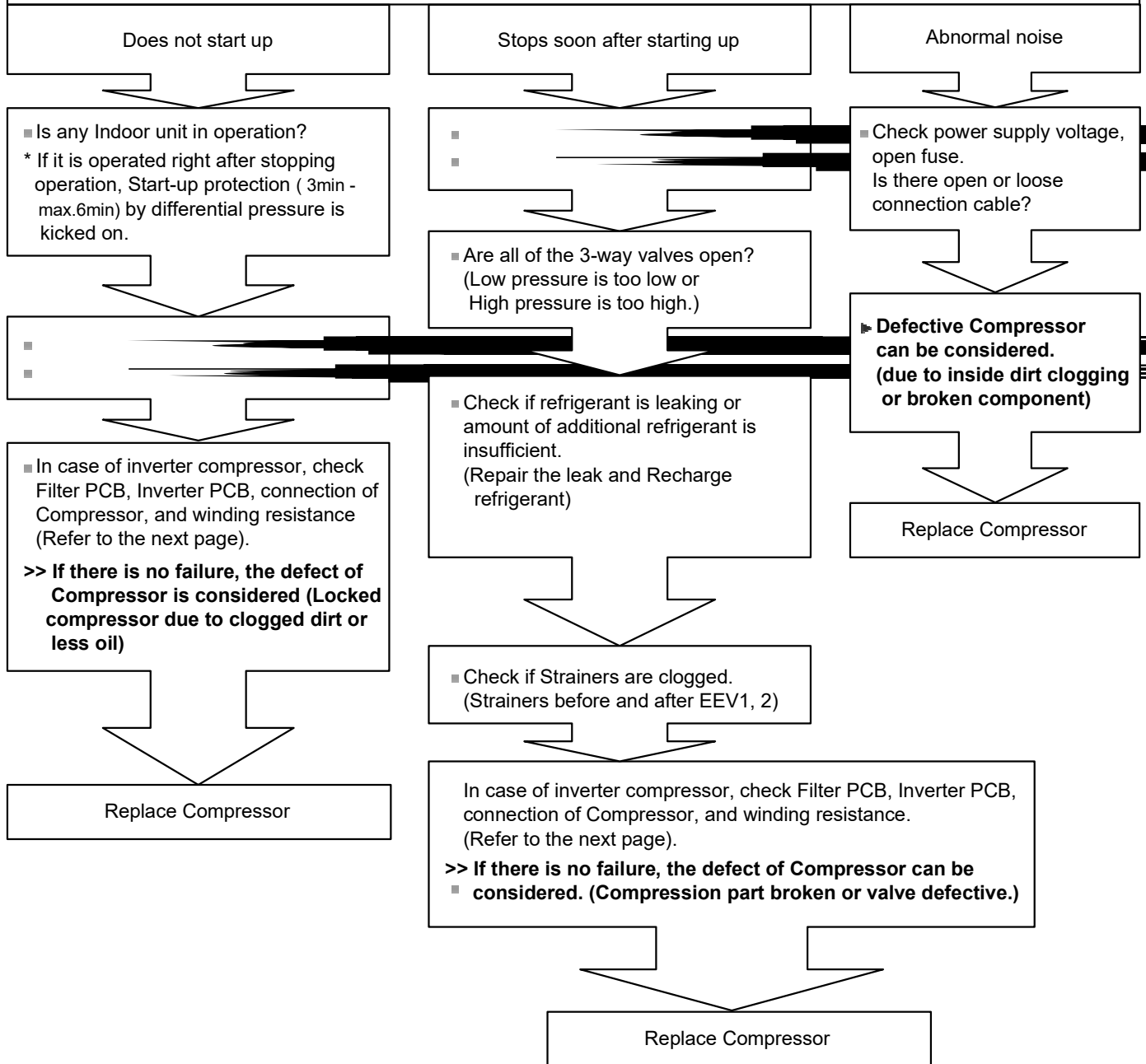

Note

If it is suspected of lack of oil, we recommend also replacing OIL RETURN VALVE A ASSY(P/N 9378745032) together with Compressor.

SERVICE PARTS INFORMATION 2

Inverter Compressor

Check Point 1 : Check Connection

- ❑ Check terminal connection of Compressor (loose or incorrect wiring)
- ❑ Check connection of magnet relay (Loose or incorrect wiring)

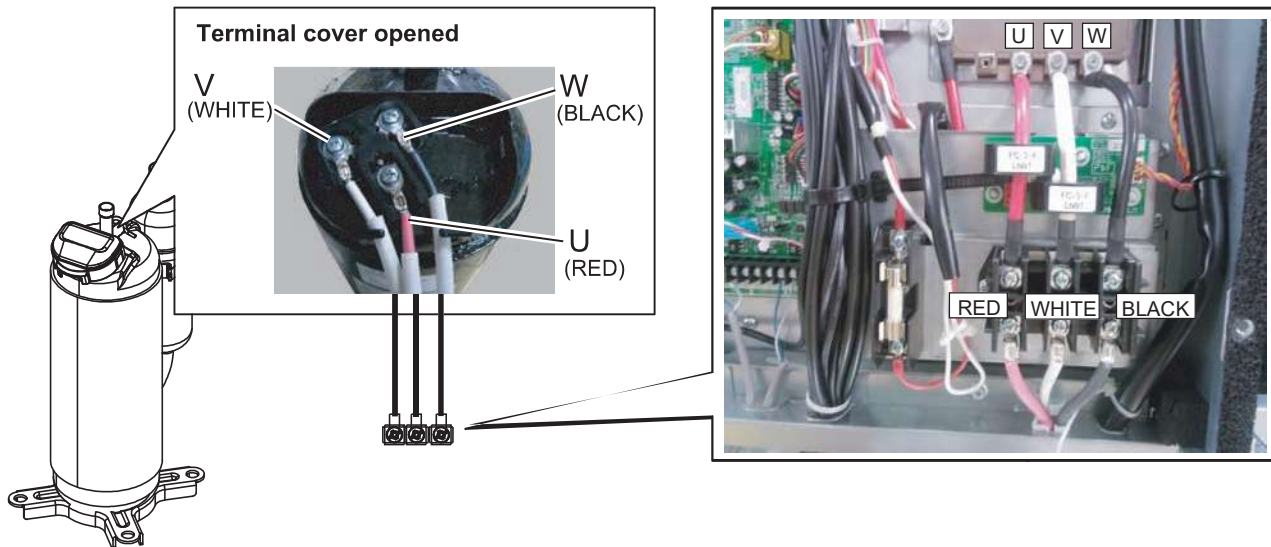

Check Point 2 : Check Winding Resistance

- ❑ Check winding resistance of each terminal
- ▶ **If the resistance value is 0Ω or infinite, replace Compressor.**

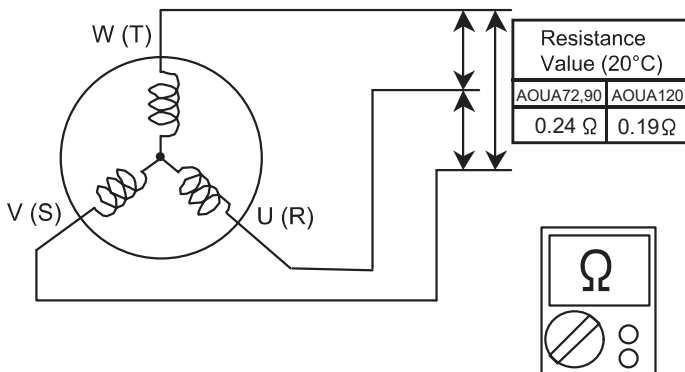

Attention!!

If Check 1, 2 are normal, make sure the following points.

- (1) Check AC voltage among each terminals from filter PCB(INV) to Diode Bridge.
(AC 208 - 230 V , voltage among L1, L2 and L3).

▶ **If it does not appear, check the power supply terminal.**

- (2) Check Voltage from Main PCB to Inverter PCB.
(DC16.0 - 20.0V between terminals of CN126 (1-2) connector of Main PCB).

▶ **If it does not appear, replace Main PCB.**

- ◆ **If both of above voltages appear, it is considered to be Inverter PCB circuit failure. Replace Inverter PCB and check operation.**



SERVICE PARTS INFORMATION 3

Main PCB
Filter PCB (Main)

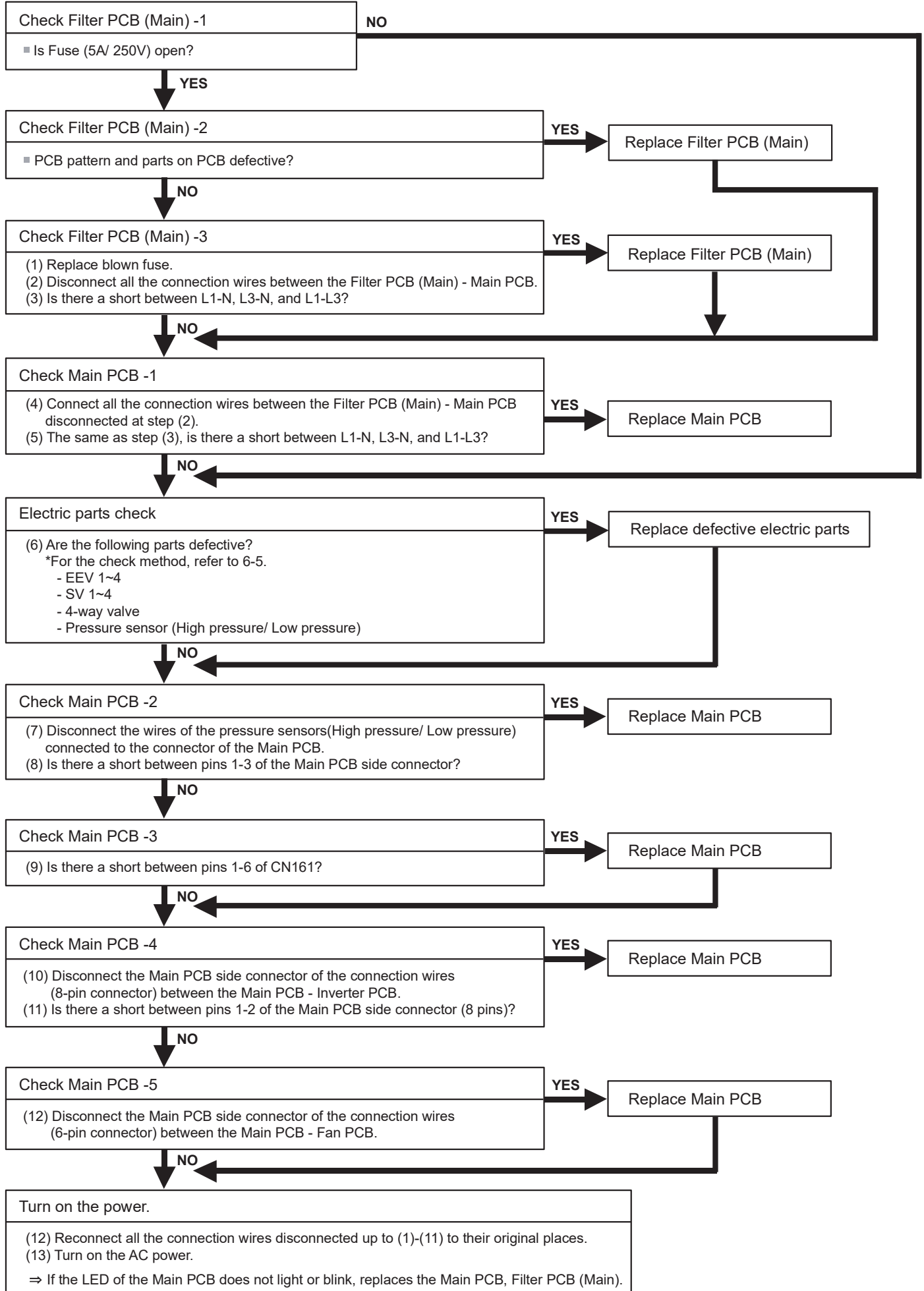

SERVICE PARTS INFORMATION 4

Inverter PCB Filter PCB (INV)

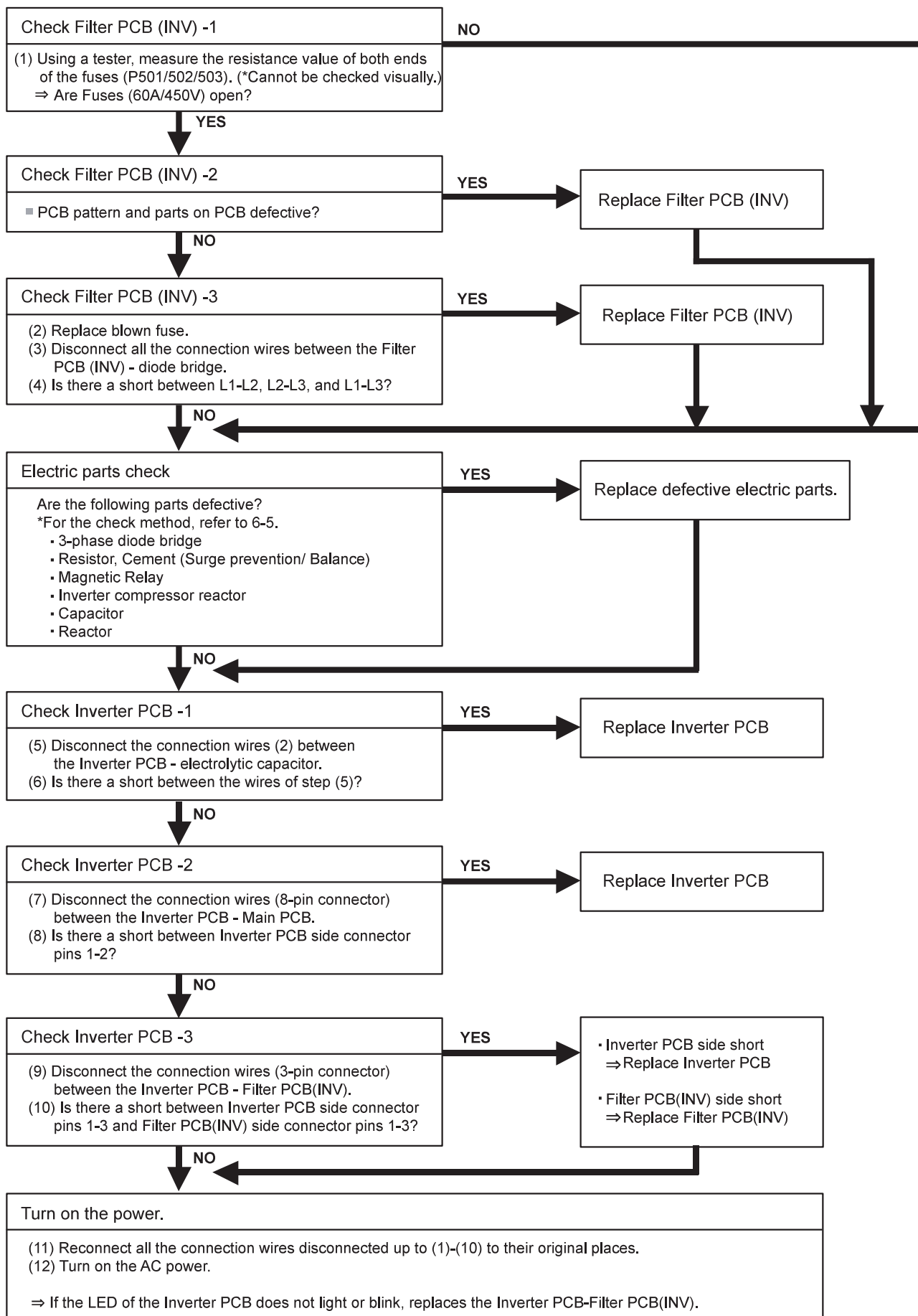

SERVICE PARTS INFORMATION 5
Fan Driver PCB

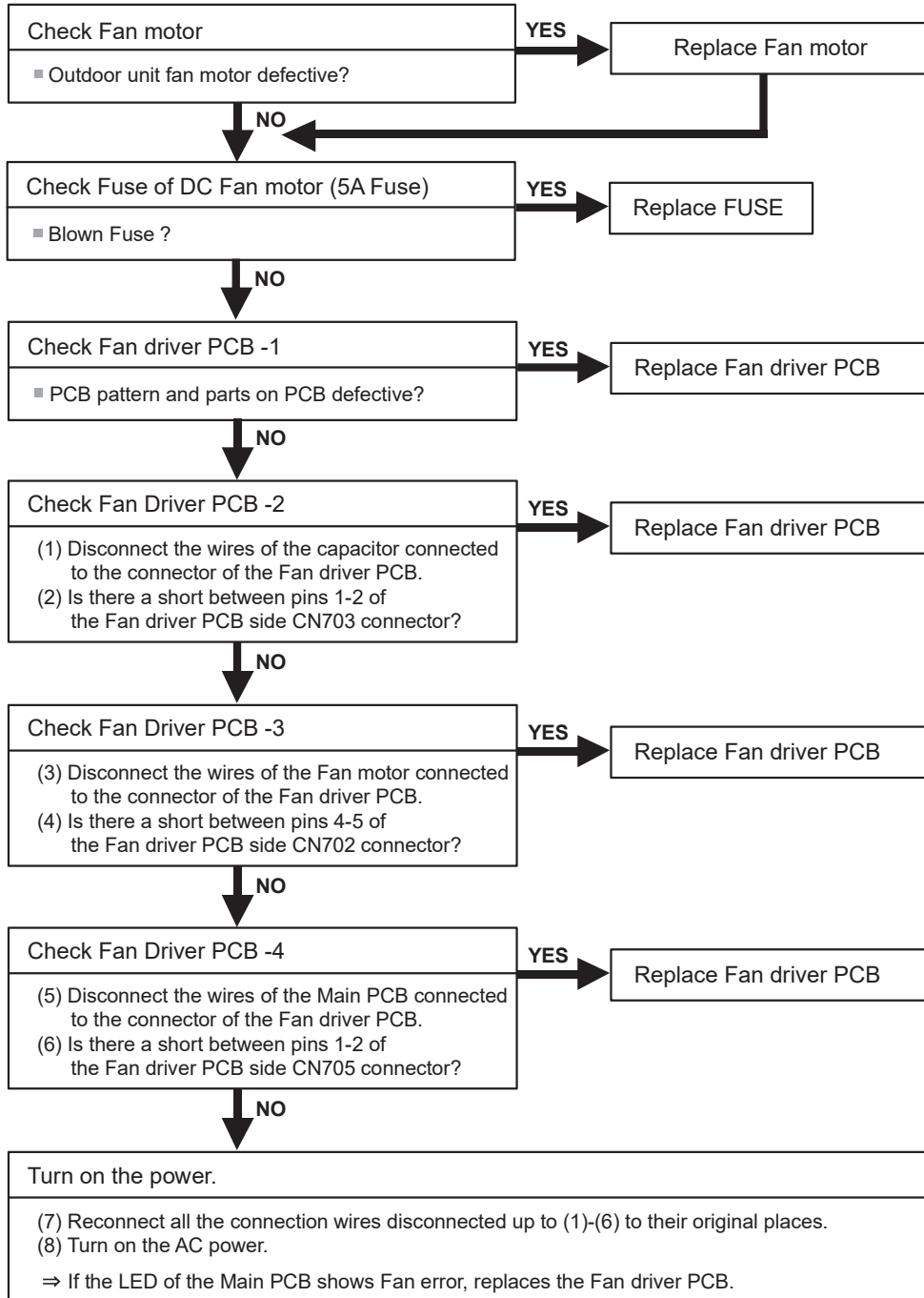

SERVICE PARTS INFORMATION 6

Filter PCB(INV)

Check Point 1

- Measure the resistance of Filter PCB(INV) by following procedure.
 1. Turn OFF the Outdoor unit(s) power supply
 2. Disconnect the connection wires between the Filter PCB(INV) - Inverter PCB.
 3. Measure the resistance value

Filter PCB(INV) [K11CE-1100HUE-FL0]

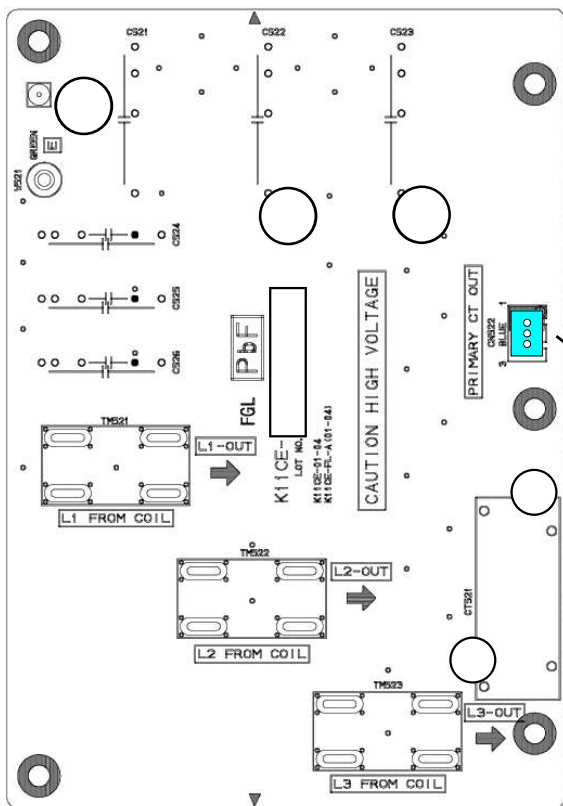

Good : 300 Ohm \pm %20

CN522 (Pin 1-3)

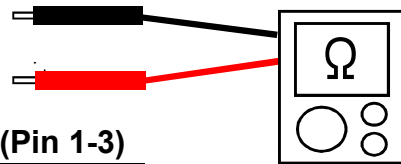

SERVICE PARTS INFORMATION 7

IPM (Mounted on Inverter PCB)

Check Point 1

① Disconnect the connection wires between the Inverter PCB - electrolytic capacitor and Inverter PCB - Inverter Compressor.

② Set the tester to the "Resistance" mode, and measure the resistance between the following terminals.

Red wire (P) - screw terminals U/V/W
White wire (N) - screw terminals U/V/W

③ Judge the result of ② as follows:

All 6 points several MΩ or greater	: Normal
1 or more points several kΩ to short	: Defective

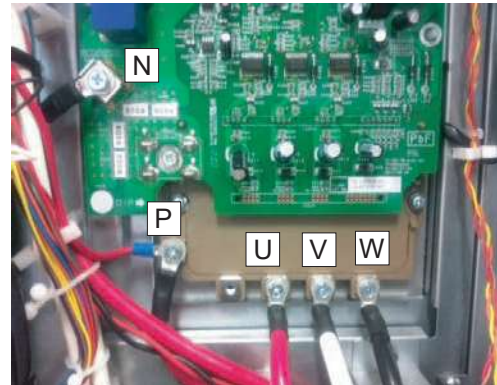

Inverter PCB

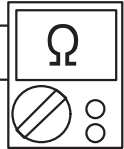

Check Point 2

④ Set the tester to the "Diode" mode, and measure the voltage value between the following terminals.

Tester +side (red)	Tester - side (black)	Tester display [V]
Terminal U	Red wire (P)	
Terminal V		
Terminal W		
White wire (N)	Terminal U	
	Terminal V	
	Terminal W	

⑤ Judge the result of ④ as follows:

All 6 points several 0.3V to 0.7V	: Normal
1 or more points under 0.1V or over load	: Defective

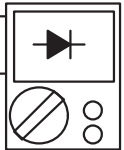

SERVICE PARTS INFORMATION 9

3-Phase Diode Bridge

Check Point 1 : Appearance check

- No fissures, breaks, damage, etc. at body and terminal section?
- Is the rear of the body coated with silicone grease?
- Are there no abnormalities at threaded parts (stripped threads, deformation, damage, etc.) ?

Check Point 2 : Electric check

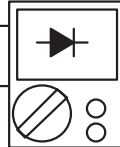

- ① In the 3-phase diode bridge single part state, set the tester to the "Diode" mode, and measure the voltage value between the following terminals.

Tester + side (red)	Tester - side (black)
Pin 1	Pin 4
Pin 2	
Pin 3	
Pin 5	Pin 1
	Pin 2
	Pin 3

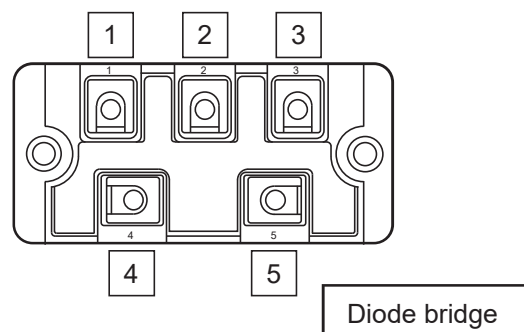

- ② Judge the result of ① as follows:

All 6 points several 0.3V to 0.7V	Normal
1 or more points under 0.1V or over load	Defective

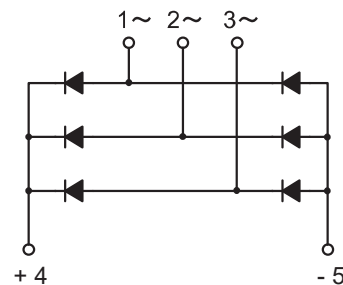

- ③ Set the tester to the "Diode" mode, and measure the voltage value between the following terminals.

Tester + side (red)	Tester - side (black)
Pin 4	Pin 1
	Pin 2
	Pin 3
Pin 1	Pin 5
Pin 2	
Pin 3	

- ④ Judge the result of ③ as follows:

All 6 points over load	Normal
1 or more points except over load	Defective

SERVICE PARTS INFORMATION 10

Reactor

Check Point 1 : Appearance check

- No fissures, breaks, damage, etc. at the body and winding section, terminals section?

Check Point 2 : Electric check

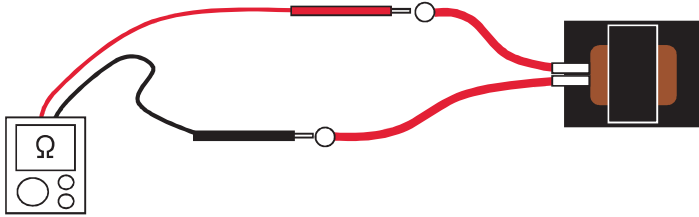

- ① Set the tester to the "Resistance" mode, and check for open/short between both ends of the reactor wire (or connector).
- ② Judge the result of ① as follows:

Short	: Normal
Open	: Abnormal (open)

SERVICE PARTS INFORMATION 11

Resistor, Cement

Check Point 1 : Appearance check

- No fissures, breaks, damage, etc. at the body and terminals section?

Check Point 2 : Electric check



1. Surge prevention resistor (connected to magnetic contactor)

- ① Set the tester to the "Resistance" mode, and measure the resistance value between the terminals. (No polarity)

- ② Judge the result of ① as follows:

9.9Ω to 10.1 Ω	Normal
Other than the above	Deteriorated, defective

2. Discharge resistor (connected to electrolytic capacitor)

- ① Set the tester to the "Resistance" mode, and measure the resistance value between the terminals. (No polarity)

- ② Judge the result of ① as follows:

53.2kΩ to 58.8kΩ	Normal
Other than the above	Deteriorated, defective

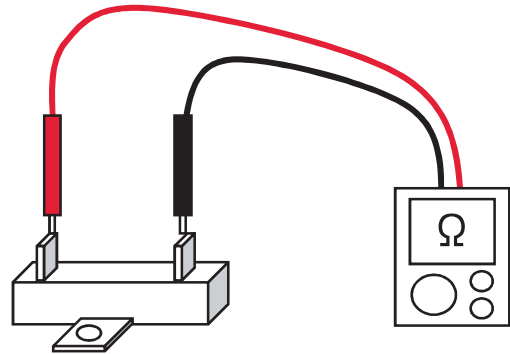

SERVICE PARTS INFORMATION 12

Terminal

Check Point 1 : Appearance check

- No fissures, breaks, damage, etc. at the body and terminals section?
- Not clogged with foreign matter?
- Are there no abnormalities at threaded parts (Stripped threads, deformation, damage, etc.) ?

Check Point 2 : Electric check

- No short between adjacent terminals?
- Conducts before and after same terminal?



SERVICE PARTS INFORMATION 13

Magnetic Relay

Check Point 1 : Appearance check

- No fissures, breaks, damage, etc. at the body and terminals section?
- Are there no abnormalities at threaded parts (Stripped threads, deformation, damage, etc.) ?

Check Point 2 : Electric check

① Set the tester to the "Resistance" mode, and check for open/short between the following terminals. (No polarity)

- Between R to U
- Between S to V
- Between T to W

② Judge the result of ① as follows:

Open	: Normal
Short	: Abnormal (contacts fused)

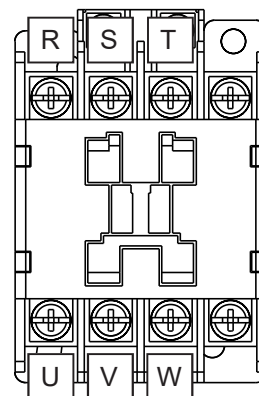

SERVICE PARTS INFORMATION 14

Indoor Unit Electronic Expansion Valve (EEV)

Check Point 1 : Check Connections

- Check Connectors (Loose connector or open cable.)

Duct, Cassette, Wall mount

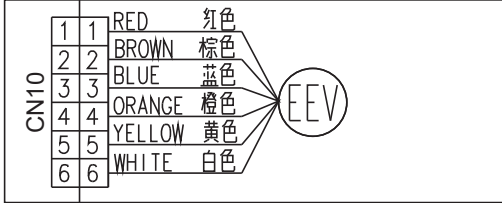

Floor/ Ceiling, Ceiling, Small Wall mount



Check Point 2 : Check Coil of EEV

- Remove connector, check each winding resistance of Coil.

Read wire	Resistance value 68°F(20°C)
White - Red	200 ± 10% Ω
Yellow - Brown	
Orange - Red	
Blue - Brown	

- If Resistance value is abnormal, replace EEV.

Check Point 3 : Check Voltage from Controller PCB

- Remove Connector and check Voltage (DC12V).
 >> If it does not appear, replace Controller PCB.

Check Point 4 : Check Noise at start up

- Turn on Power and check operation noise.
 >> If an abnormal noise does not show, replace Controller PCB.

Check Point 5 : Check Opening and Closing Operation of Valve

When Valve is closed, it has a temp. difference between Inlet and Outlet.

CLOSE

Example : Hot Gas Pipe (In)

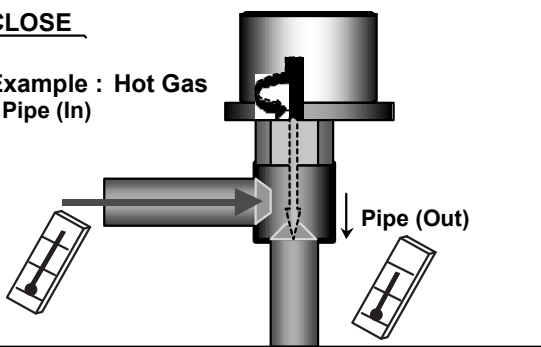

If it is open, it has no temp. difference between Inlet and Outlet.

OPEN

Example : Hot Gas Pipe (In)

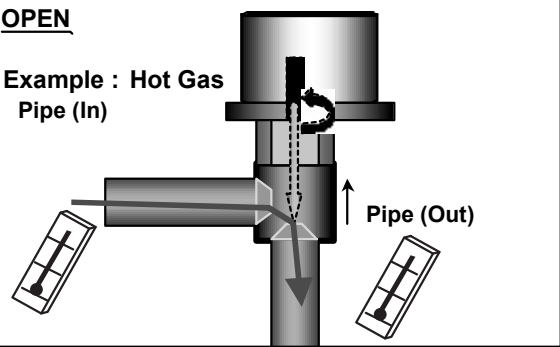

Check Point 6 : Check Strainer

Strainer normally does not have temperature difference between inlet and outlet as shown in (1), but if there is a difference as shown in (2), there is a possibility of inside clogged. In this case, replace Strainer.

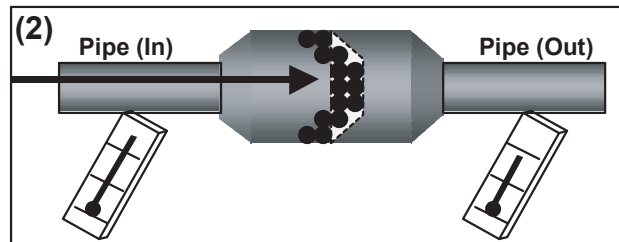
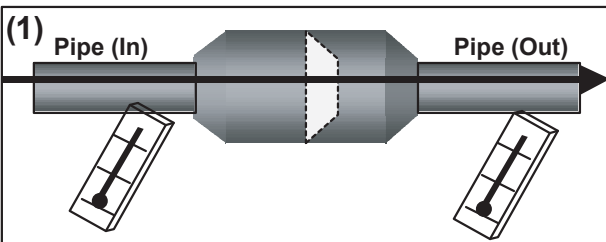

SERVICE PARTS INFORMATION 15

Outdoor Unit Electronic Expansion Valve (EEV1)

Check Point 1 : Check Connections

- Check connection of connector (CN116) (Loose connector or open cable)

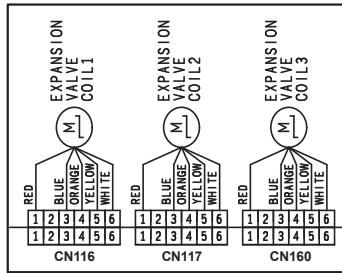

Check Point 2 : Check Coil of EEV1

- Remove connector, check each winding resistance of Coil.

Read wire	Resistance value 68°F(20°C)
White - Red	$46 \pm 4 \% \Omega$ 
Yellow - Red	
Orange - Red	
Blue - Red	

- If Resistance value is abnormal, replace EEV1.

Check Point 3 : Check Noise at start up

- Turn on Power and check operation noise.

>> If an abnormal noise does not show, replace Controller PCB.

Check Point 4 : Check Voltage from Controller PCB

- Remove Connector and check Voltage (DC12V).

>> If it does not appear, replace Controller PCB.

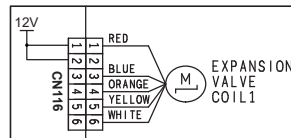

Check Point 5 : Check Opening and Closing Operation of Valve

Note : Check the EEV1 in the state of 4-way1 valve is ON.

When EEV1 is closed, it has no temp. difference between Inlet and Outlet.

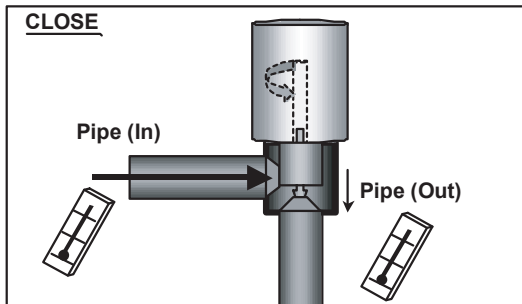

If it is open, it has a temp. difference between Inlet and Outlet. Outlet temp. is near Low-pressure saturated temp.

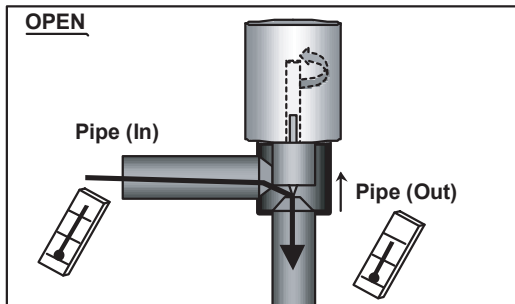

In the following cases, even if EEV1 is closed, there may be a difference in temp.

- On comp. start-up
- Just after switching the 4-way valve1
- Just after switching the EEV1 (Open --> Close)

Note

If valve opening is 12~51pls, the check of temp. cannot be performed. Check temp. at the other valve opening.

Check Point 6 : Check Strainer

Strainer normally does not have temperature difference between inlet and outlet as shown in (1), but if there is a difference as shown in (2), there is a possibility of inside clogged. In this case, replace Strainer.

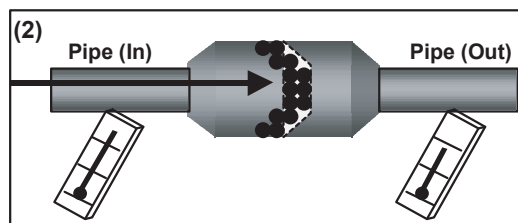
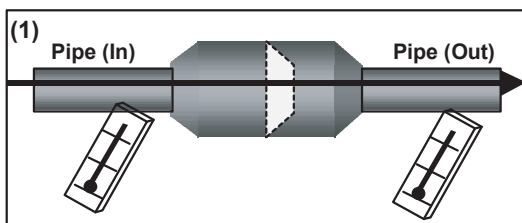

SERVICE PARTS INFORMATION 16

Outdoor Unit Electronic Expansion Valve (EEV2)

Check Point 1 : Check Connections

- Check connection of connector (CN117) (Loose connector or open cable)

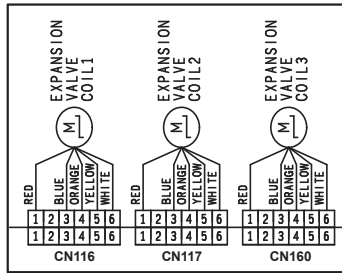

Check Point 2 : Check Coil of EEV2

- Remove connector, check each winding resistance of Coil.

Read wire	Resistance value 68°F(20°C)
White - Red	$46 \pm 4 \% \Omega$ 
Yellow - Red	
Orange - Red	
Blue - Red	

- If Resistance value is abnormal, replace EEV2.

Check Point 3 : Check Noise at start up

- Turn on Power and check operation noise.

>> If an abnormal noise does not show, replace Controller PCB.

Check Point 4 : Check Voltage from Controller PCB

- Remove Connector and check Voltage (DC12V).

>> If it does not appear, replace Controller PCB.

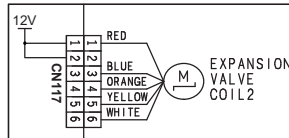

Check Point 5 : Check Opening and Closing Operation of Valve

Note : Check the EEV2 in the state of 4-way valve2 is ON.

When EEV2 is closed, it has no temp. difference between Inlet and Outlet.

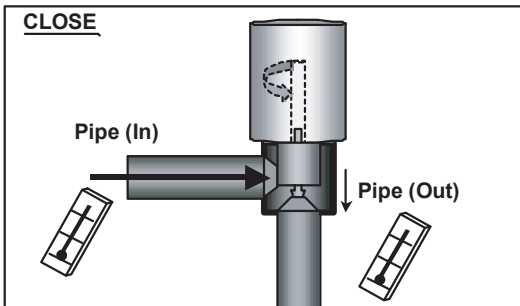

If it is open, it has a temp. difference between Inlet and Outlet. Outlet temp. is near Low-pressure saturated temp.

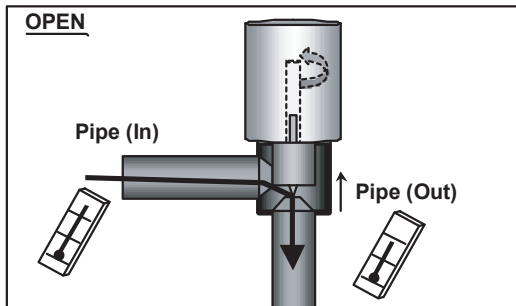

In the following cases, even if EEV2 is closed, there may be a difference in temp.

- On comp. start-up
- Just after switching the 4-way valve2
- Just after switching the EEV2 (Open --> Close)

Note

If valve opening is 12~51pls, the check of temp. cannot be performed. Check temp. at the other valve opening.

Check Point 6 : Check Strainer

Strainer normally does not have temperature difference between inlet and outlet as shown in (1), but if there is a difference as shown in (2), there is a possibility of inside clogged. In this case, replace Strainer.

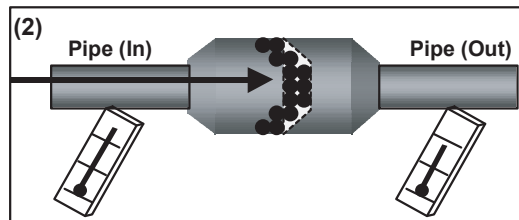
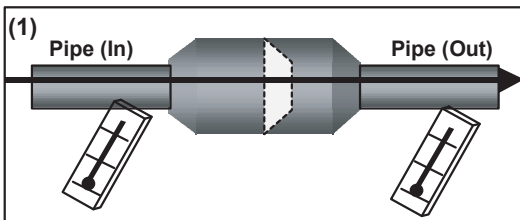

SERVICE PARTS INFORMATION 17

Outdoor Unit Electronic Expansion Valve (EEV3)

Check Point 1 : Check Connections

- Check connection of connector (CN160) (Loose connector or open cable)

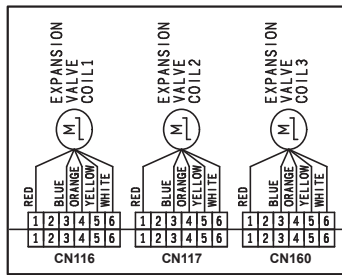

Check Point 2 : Check Coil of EEV3

- Remove connector, check each winding resistance of Coil.

Read wire	Resistance value 68°F(20°C)
White - Red	$46 \pm 4 \% \Omega$ 
Yellow - Red	
Orange - Red	
Blue - Red	

- If Resistance value is abnormal, replace EEV3.

Check Point 3 : Check Noise at start up

- Turn on Power and check operation noise.

>> If an abnormal noise does not show, replace Controller PCB.

Check Point 4 : Check Voltage from Controller PCB

- Remove Connector and check Voltage (DC12V).

>> If it does not appear, replace Controller PCB.

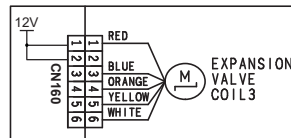

Check Point 5 : Check Opening and Closing Operation of Valve

When EEV3 is closed, it has no temp. difference between Inlet and Outlet.

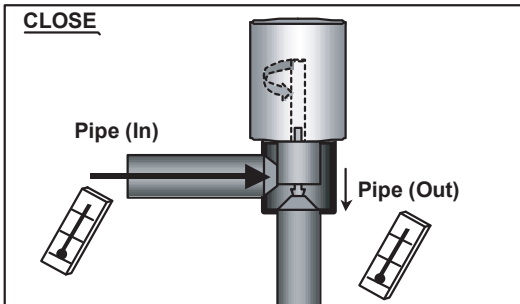

If it is open, it has a temp. difference between Inlet and Outlet. Outlet temp. is near Low-pressure saturated temp.

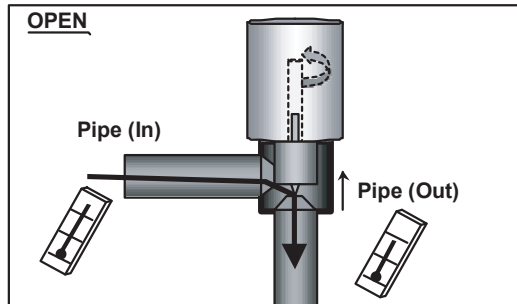

In the following cases, even if EEV3 is closed, there may be a difference in temp.

- On comp. start-up
- Just after switching the EEV3 (Open --> Close)

Note

If valve opening is 12~51pls, the check of temp. cannot be performed. Check temp. at the other valve opening.

Check Point 6 : Check Strainer

Strainer normally does not have temperature difference between inlet and outlet as shown in (1), but if there is a difference as shown in (2), there is a possibility of inside clogged. In this case, replace Strainer.

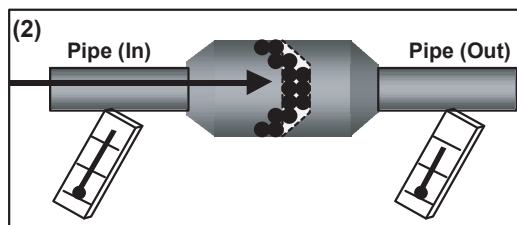
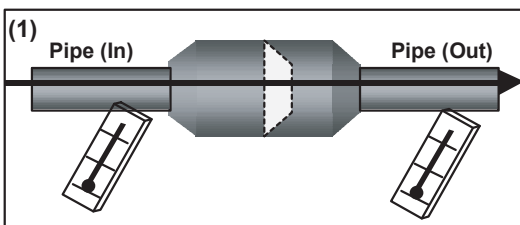

SERVICE PARTS INFORMATION 18

Outdoor Unit Solenoid Valve (SV1, SV2, SV3, SV4)

Check Point 1 : Check connections

- Check connection of connector.
(Loose connector or open cable)

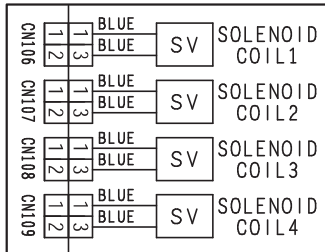

Check Point 2 : Check Solenoid Coil

- Remove connector and check if coil is open.

Solenoid Coil	Resistance value	Resistance value 68°F(20°C)
SV1	1324Ω ±7%	
SV2, SV3	1495Ω ±7%	
SV4	1434.5Ω ±10%	

>> **If Resistance value is abnormal, replace Solenoid Coil.**

Check Point 3 : Check Voltage from Main PCB

- Remove connector and check the voltage (AC208- 230V).

>> **If the voltage does not appear, replace Main PCB.**

Check Point 4-1 : Check opening & closing operation of SV1, SV2

- Depending on either during operation or protection control, check if Valve is operating normally.
(When Valve opens, Inlet and Outlet temperature is raised.)

Normal Operation
Pipe (In) TEMP. Normal,
Pipe (Out) TEMP.Normal

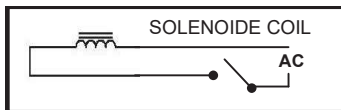
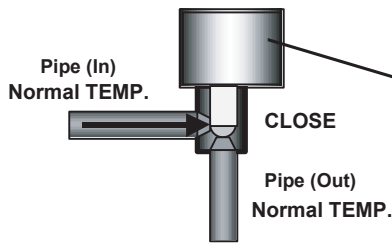

**Protection Function (Refer to 2-6-1),
Special Operation**
Pipe (In) TEMP. Hi,
Pipe (Out) TEMP. Hi

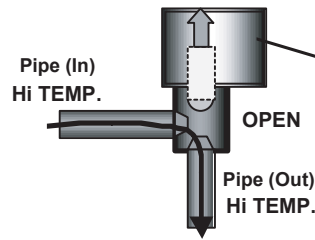

- If the valve closes by removing the connector of the valve which does not close, it is considered to be Main PCB failure. Replace Main PCB.

- If it does not close by removing connector, there is a possibility of (1) clogging by dirt, or (2) deformation by the heat at the time of Solenoid Valve installation. In this case, replace Solenoid Valve.

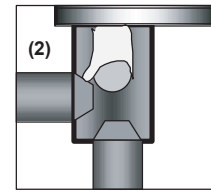
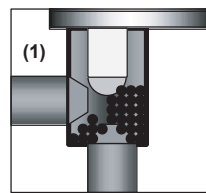

Check Point 4-2 : Check operation of SV3

- Check the operation noise when the connector of SV3 is removed.
 - When SV3 is open
 - The sound of operation noise is heard ----> Normal
 - The sound of operation noise is not heard. ----> Replace SV3
 - When SV3 is closed
 - The sound of operation noise is heard ----> Replace Main PCB
 - The sound of operation noise is not heard. ----> Normal

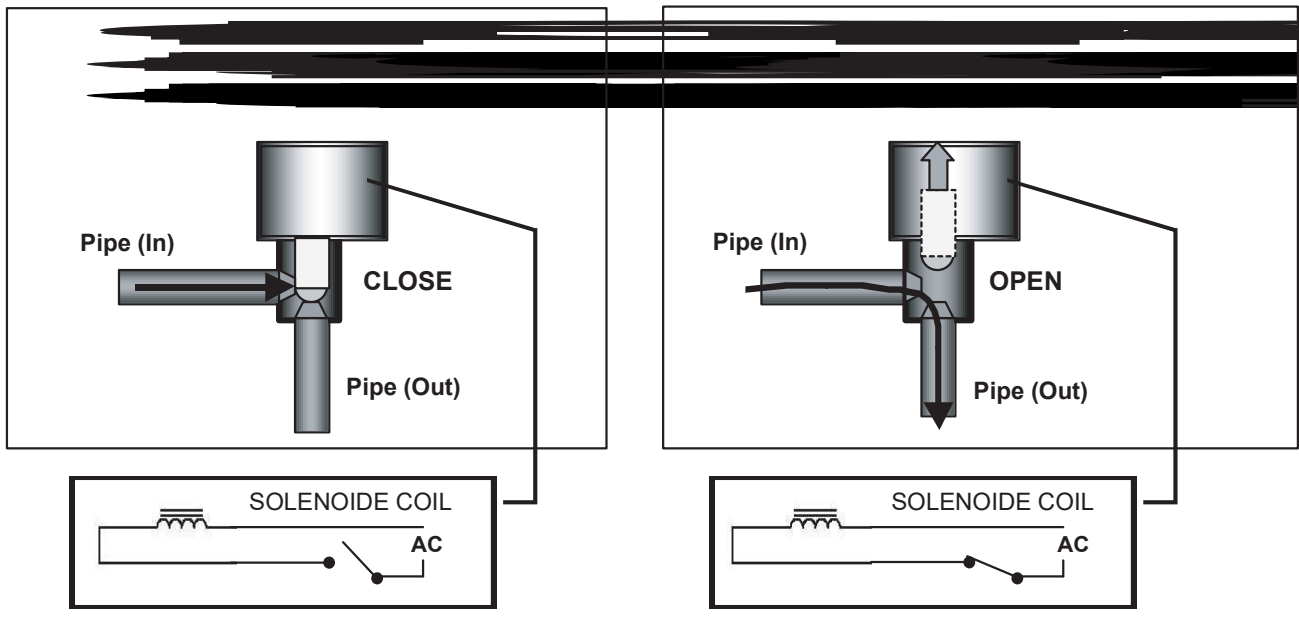

Check Point 4-3 : Check opening & closing operation of SV4

- Check if Valve is operating normally.
(When Valve opens, Inlet and Outlet temperature is raised.)

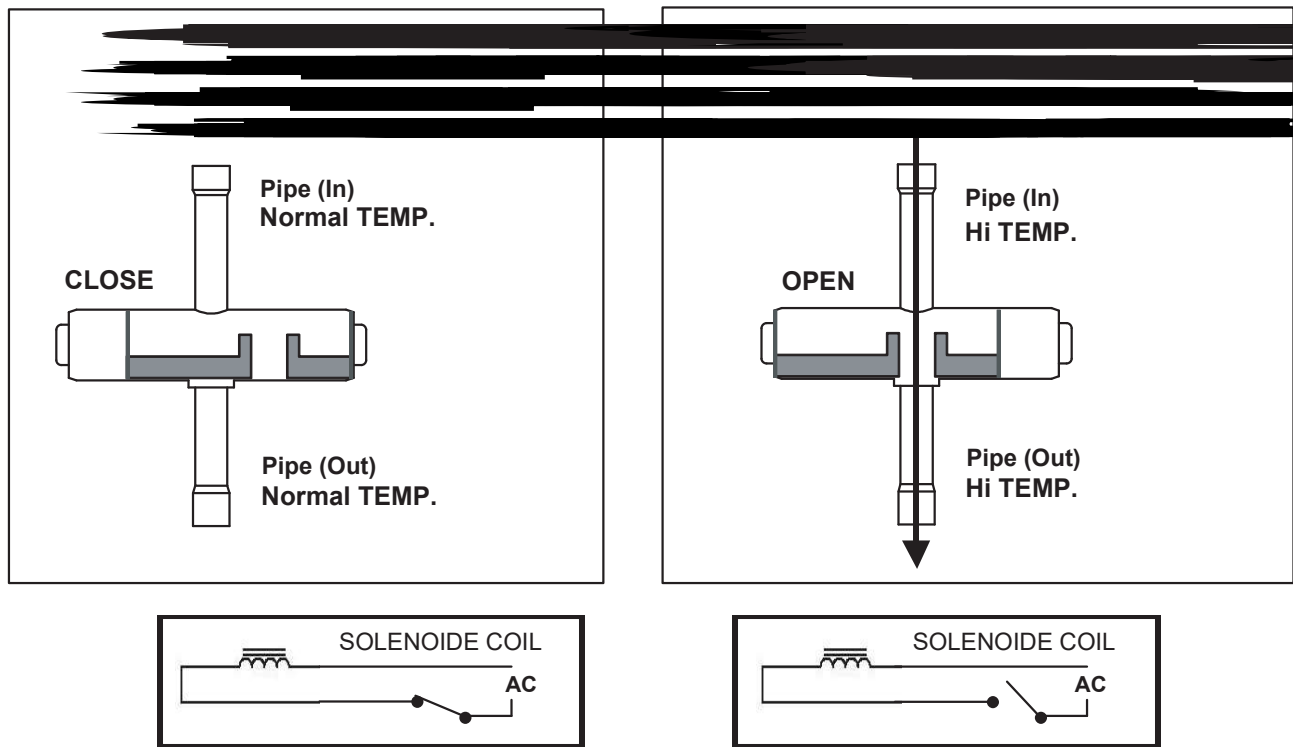

- If the valve does not open when the connector of SV4 is removed from Main PCB, Replace SV4.

SERVICE PARTS INFORMATION 19

4-WAY VALVE 1 (2)

Check Point 1 : Check Circuit connection

- Check the connection of connector CN105 (CN156)

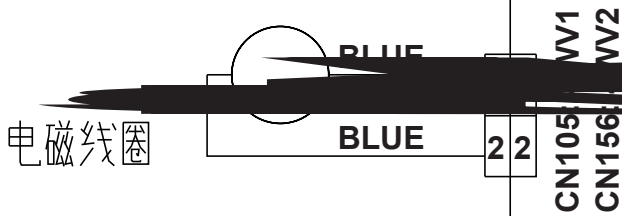

Check Point 2 : Check Solenoid Coil

- Remove CN105 (CN156) from PCB and check the resistance value of coil

Resistance Value
= 1.725kΩ ± 10%

- ☆ If it is Open or abnormal resistance value, replace Solenoid Coil

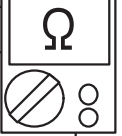

Check Point 3: Check Operation of 4 Way Valve

- Check each piping temperature, and confirm the location of the valve by the temperature difference.

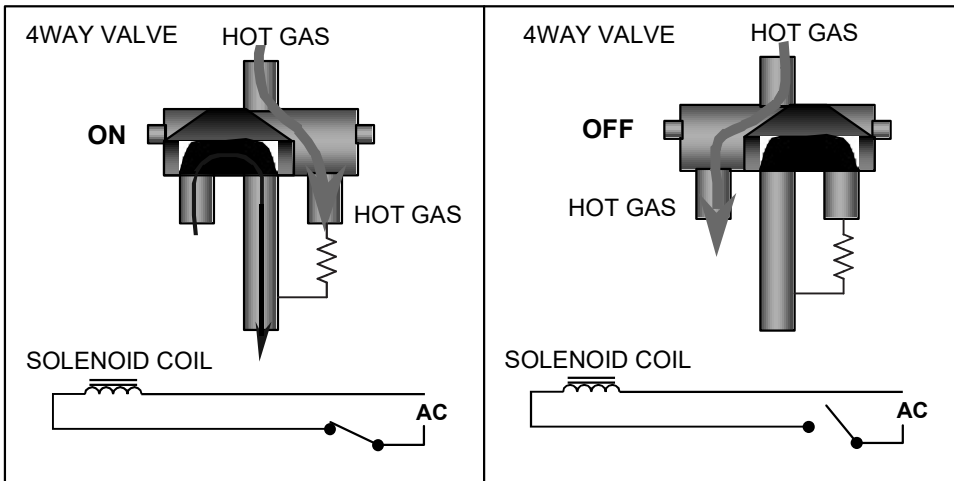

- ☆ If the valve location is not proper, replace 4 way valve.

Check Point 4: Check Voltage of Solenoid Coil

- If CN105 (CN156) of Control PCB dose not Show (AC208- 230V) during Heating operation (Compressor is in operation), replace Main PCB.

SERVICE PARTS INFORMATION 20

Indoor Unit AC Fan Motor

Check Point : ARUH36TLAV (High Static Pressure Duct Type)

- Check each winding resistance of the motor
- ▶ **If Resistance value is abnormal, replace motor.**

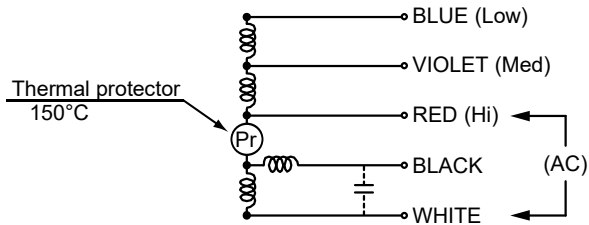

Lead wire	Resistance value
White – Red	19.8 Ω \pm 7%
Red – Black	23.4 Ω \pm 7%
Red – Violet	8.75 Ω \pm 7%
Violet – Blue	8.75 Ω \pm 7%

at 20°C

Check Point : ARUH48/ 60TLAV (High Static Pressure Duct Type)

- Check each winding resistance of the motor
- ▶ **If Resistance value is abnormal, replace motor.**

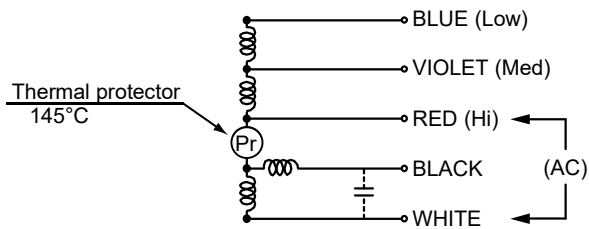

Lead wire	Resistance value
White – Red	8.94 Ω \pm 7%
Red – Black	9.56 Ω \pm 7%
Red – Violet	3.41 Ω \pm 7%
Violet – Blue	2.65 Ω \pm 7%

at 20°C

SERVICE PARTS INFORMATION 21

Indoor unit fan motor < DC motor >

⚠ When you approach this part, please cut off the power supply and wait for a while until DC voltage has been discharged.

Check Point 1 : Check rotation of Fan

- Rotate the fan by hand when operation is off.
(Check if fan is caught, dropped off or locked motor)
- >>**If Fan or Bearing is abnormal, replace it.**

Check Point 2 : Check resistance of Indoor Fan Motor

- Refer to below. Circuit-test "Vm" and "GND" terminal.
(Vm: DC voltage, GND: Earth terminal)
- >>**If they are short-circuited (below 300 kΩ), replace Indoor fan motor**

Pin number (wire color)	Terminal function (symbol)
1 (Brown or Blue)	Feed back (FG)
2 (Yellow)	Speed command (Vsp)
3 (White)	Control voltage (Vcc)
4 (Black)	Earth terminal (GND)
5	No function
6 (Red)	DC voltage (Vm)

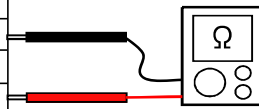

SERVICE PARTS INFORMATION 22

Outdoor unit fan motor

⚠ When you approach this part, please cut off the power supply and wait for a while until DC voltage has been discharged.

Check Point 1 : Check rotation of Fan

- Rotate the fan by hand when operation is off.
(Check if fan is caught, dropped off or locked motor)
- >>**If Fan or Bearing is abnormal, replace it.**

Check Point 2 : Check resistance of Outdoor Fan Motor

- Refer to below. Circuit-test " Winding coil resistance U, V, W." and the Location sensor Circuit test
- >>**If they are other resistance value, replace Outdoor fan motor.**

Pin number (wire color)	Terminal function (symbol)
U (Red) - W (Black)	2.8 Ω
V (white) - U (Red)	
W (Black) - V (White)	
1 (Yellow) - 4 (Pink)	9.3 K Ω
2 (Blue) - 4 (Pink)	
3 (Orange) - 4 (Pink)	
4 (Pink) - 5 (Gray)	More than 1.2 K Ω
1 or 2 or 3 - 5 (Gray)	More than 10 K Ω

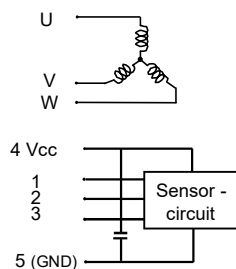

SERVICE PARTS INFORMATION 23

Discharge Pressure Sensor Suction Pressure Sensor

1. Discharge Pressure Sensor

Check Point : Check Voltage from Main PCB

- With the connector connected to the PCB, measure the voltage between CN118:2-3 of the Main PCB.

- Characteristics of pressure sensor

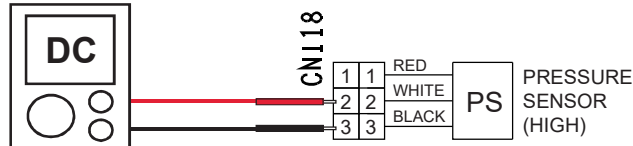
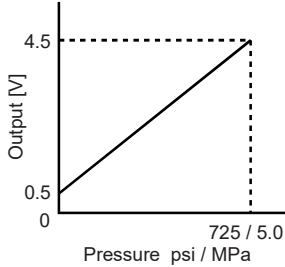

psi	0.0	14.5	29.0	43.5	58.0	72.5	101.5	116.0	130.5	145.0	174.0	203.0	232.0	261.0	290.0
MPa	0.00	0.10	0.20	0.30	0.40	0.50	0.70	0.80	0.90	1.00	1.20	1.40	1.60	1.80	2.00
Output (V)	0.50	0.58	0.66	0.74	0.82	0.90	1.06	1.14	1.22	1.30	1.46	1.62	1.78	1.94	2.10

psi	319.0	348.0	377.0	406.0	435.0	464.0	493.0	522.0	551.0	580.0	609.0	638.0	667.0	696.0	725.0
MPa	2.20	2.40	2.60	2.80	3.00	3.20	3.40	3.60	3.80	4.00	4.20	4.40	4.60	4.80	5.00
Output (V)	2.26	2.42	2.58	2.74	2.90	3.06	3.22	3.38	3.54	3.70	3.86	4.02	4.18	4.34	4.50

2. Suction Pressure Sensor

Check Point : Check Voltage from Main PCB

- With the connector connected to the PCB, measure the voltage between CN119:2-3 of the Main PCB.

- Characteristics of pressure sensor

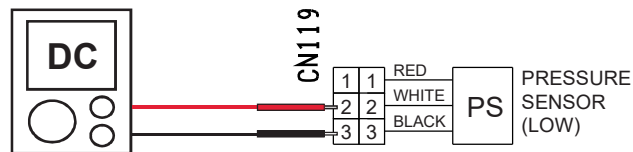
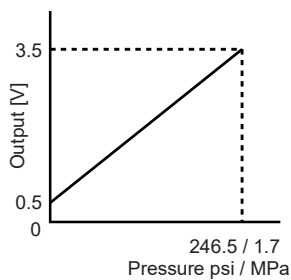

psi	0.0	14.5	29.0	43.5	58.0	72.5	101.5	116.0	130.5	145.0	159.5	174.0	188.5	203.0	217.5
MPa	0.00	0.10	0.20	0.30	0.40	0.50	0.70	0.80	0.90	1.00	1.10	1.20	1.30	1.40	1.50
Output (V)	0.50	0.68	0.85	1.03	1.21	1.38	1.74	1.91	2.09	2.27	2.44	2.62	2.79	2.97	3.15

psi	232.0	246.5
Mpa	1.60	1.70
Output (V)	3.32	3.50

SERVICE PARTS INFORMATION 24

Pressure Switch

• Type of contact

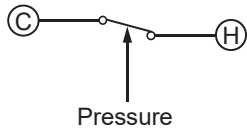

• Characteristics of pressure switch

Contact : Short ⇒ Open	4.2±0.1MPa (609 ±14.5 psi)
Contact : Open ⇒ Short	3.2±0.15MPa (464 ±21.8 psi)

SERVICE PARTS INFORMATION 25

Thermistor

Check Point : Check Thermistor resistance value

- Remove connector and check Thermistor resistance value.

Temperature [°F]	Temperature [°C]	Resistance Value [kΩ]			
		Thermistor A	Thermistor B	Thermistor C	Thermistor D
- 4	- 20	---	---	105.4	---
14	- 10	---	27.8	58.2	27.4
23	- 5	---	21.0	44.0	20.7
32	0	168.6	16.1	33.6	15.8
41	5	129.8	12.4	25.9	12.2
50	10	100.9	9.6	20.2	9.5
59	15	79.1	7.6	15.8	7.5
68	20	62.6	6.0	12.5	5.9
77	25	49.8	4.8	10.0	4.7
86	30	40.0	3.8	8.0	3.8
104	40	26.3	2.5	5.3	2.5
122	50	17.8	1.7	3.6	1.7
140	60	12.3	1.2	---	1.2
158	70	8.7	---	---	0.8
176	80	6.3	---	---	0.6
194	90	4.6	---	---	0.4
212	100	3.4	---	---	0.3
230	110	2.6	---	---	---
248	120	2.0	---	---	---

Applicable Thermistors

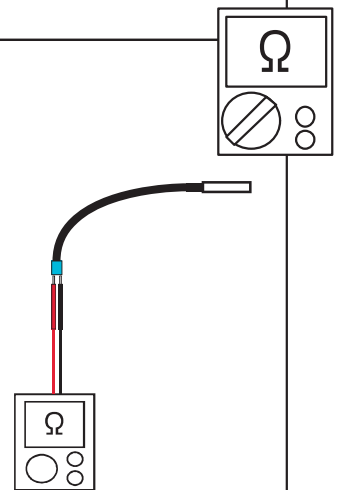

SERVICE PARTS INFORMATION 26

RB Unit Solenoid Valve
(SV1, SV2, SV3, SV4, SV5, SV6)

Check Point 1 : Check Solenoid Coil

- Remove connector and check if coil is open.

Solenoid Coil	Resistance value
SV1,SV2,SV3,SV4,SV5,SV6	1.35K Ω \pm 7%

>> If Resistance value is abnormal, replace Solenoid Coil.



Check Point 2: Check Voltage from Main PCB

- Remove connector and check the voltage (AC208- 230V).

>> If the voltage does not appear, replace Main PCB.

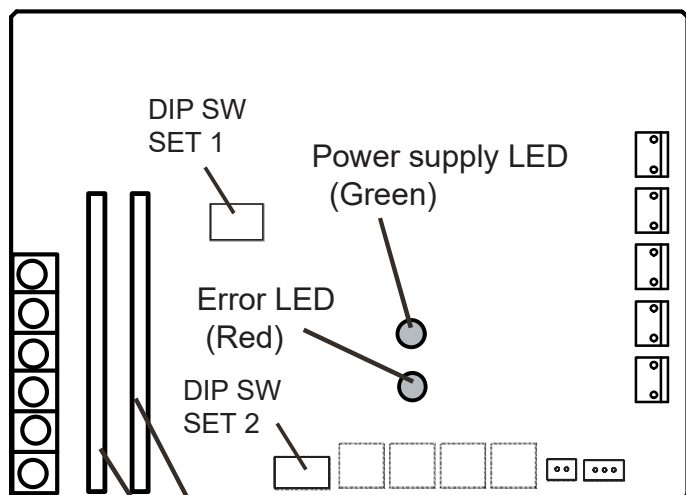

SV1	Green	SVD1
SV2	Blue	SVB2
SV3	Black	SVS
SV4	White	SVS
SV5	Red	SVS
SV6	Yellow	SVS



AIRSTAGE™ VR-II

Variable Refrigerant Flow System

5. APPENDING DATA (UNIT)

